



**Question(s):** 14/15

Geneva, 20 November – 1 December 2023

**TD**

**Source:** Editor G.876

**Title:** Draft Amendment 1 to Recommendation ITU-T G.876 “Management Requirement and Information Model for the optical media network” (for consent)

**Contact:** Qilei Wang  
ZTE Corporation  
P. R. China  
Tel: +86 153 6617 7122  
E-mail: [wang.qilei@zte.com.cn](mailto:wang.qilei@zte.com.cn)

**Contact:** Yuji Tochio  
Fujitsu  
Japan  
Tel: +81-44-280-9936  
E-mail: [tochio@fujitsu.com](mailto:tochio@fujitsu.com)

**Abstract:** This document provides the editor draft of Recommendation [ITU-T G.876] “Management Requirement and Information Model for the optical media network” (v1.0.64). The document will be Amendment 1 to Recommendation G.876.

**Document history:**

Version	Date	Description
1.0.1	Dec 2021 (TD848/3)	Initial version of the editor draft, which is based on the inforced version of G.876 (08/2021).
1.0.2	April 2022 (cd14d-07)	Align the style of draft to Amendment 1.  Updates - Add new clause “7.2.4 OCh object classes” per cd14d-10r1 - Updates text in 7.2.2.2 per cd14d-10r1
1.0.3	Aug 2022 (cd14d-07r1=TD48/3)	Updates - Appendix III per C2709 and cd14d-13 - Update Papyrus model to payprus 2020 version
1.0.4	Sep 2022 (cd14-53r1 =TD48r1/3)	Updates - PMS TTP model per C164 - Oxs protection model per C237 - OTS TTP, OMS TTP, OMS CTP, OTSiA TTP, OTSiA CTP, OCh TTP, OCh CTP per C238 - Add one editor note on optical power monitoring and optical power control, which is moved from G.7710 here
1.0.5	April 2023 (cd14-53r1=TD111r1/3)	Updates - Update clause 6 per C375.

Version	Date	Description
<a href="#">1.0.6</a>	<a href="#">Nov 2023</a> <a href="#">(cd14-66= D238/PLEN)</a>	<a href="#">Updates</a> - <a href="#">Update according to C685, C836, C838</a> - <a href="#">Please be noted that the UML version is 1.0.5.</a>

## Draft Recommendation ITU-T G.876

### Management requirements and information model for the optical media network Amendment 1

#### Summary

Recommendation [ITU-T G.876] describes the management requirements and the information model for network elements (NEs) that contain optical media layer functions defined by ITU-T equipment Recommendations based on the [ITU-T G.807] architecture, e.g., Recommendation [ITU-T G.798].

The management requirements are based on Recommendation [ITU-T G.7710], and the information model is based on [ITU-T G.7711] object classes.

~~This~~ first version of ~~this~~ Recommendation ~~ITU-T G.876~~ provides ~~only~~ the optical media layer management requirements and information models for the optical transport network (OTN).

The Amendment 1 of this Recommendation creates OCh information model, PMS (Physical Media Section) model, the generic structure of the media construct and the use case for point-to-point interfaces. It also updates the requirements of configuration management and performance management, as well as the existing UML model (i.e., OTS, OMS and OTSiA object classes).

#### History

Edition	Recommendation	Approval	Study Group	Unique ID*
1.0	ITU-T G.876	2021-08-22	15	<a href="http://handle.itu.int/11.1002/1000/14713">11.1002/1000/14713</a>
<u>1.1</u>	<u>ITU-T G.876</u>		<u>15</u>	

#### Keywords

Information models, management, optical media [layer](#).

---

\* To access the Recommendation, type the URL <http://handle.itu.int/> in the address field of your web browser, followed by the Recommendation's unique ID. For example, <http://handle.itu.int/11.1002/1000/14713>.

## FOREWORD

The International Telecommunication Union (ITU) is the United Nations specialized agency in the field of telecommunications, information and communication technologies (ICTs). The ITU Telecommunication Standardization Sector (ITU-T) is a permanent organ of ITU. ITU-T is responsible for studying technical, operating and tariff questions and issuing Recommendations on them with a view to standardizing telecommunications on a worldwide basis.

The World Telecommunication Standardization Assembly (WTSA), which meets every four years, establishes the topics for study by the ITU-T study groups which, in turn, produce Recommendations on these topics.

The approval of ITU-T Recommendations is covered by the procedure laid down in WTSA Resolution 1.

In some areas of information technology which fall within ITU-T's purview, the necessary standards are prepared on a collaborative basis with ISO and IEC.

## NOTE

In this Recommendation, the expression "Administration" is used for conciseness to indicate both a telecommunication administration and a recognized operating agency.

Compliance with this Recommendation is voluntary. However, the Recommendation may contain certain mandatory provisions (to ensure, e.g., interoperability or applicability) and compliance with the Recommendation is achieved when all of these mandatory provisions are met. The words "shall" or some other obligatory language such as "must" and the negative equivalents are used to express requirements. The use of such words does not suggest that compliance with the Recommendation is required of any party.

## INTELLECTUAL PROPERTY RIGHTS

ITU draws attention to the possibility that the practice or implementation of this Recommendation may involve the use of a claimed Intellectual Property Right. ITU takes no position concerning the evidence, validity or applicability of claimed Intellectual Property Rights, whether asserted by ITU members or others outside of the Recommendation development process.

As of the date of approval of this Recommendation, ITU had not received notice of intellectual property, protected by patents/software copyrights, which may be required to implement this Recommendation. However, implementers are cautioned that this may not represent the latest information and are therefore strongly urged to consult the appropriate ITU-T databases available via the ITU-T website at <http://www.itu.int/ITU-T/ipr/>.

© ITU 2021

All rights reserved. No part of this publication may be reproduced, by any means whatsoever, without the prior written permission of ITU.

**Table of Contents**

	<b>Page</b>
1 Scope.....	1
2 References.....	1
3 Definitions .....	2
3.1 Terms defined elsewhere .....	2
3.2 Terms defined in this Recommendation.....	2
4 Abbreviations and acronyms .....	2
5 Conventions .....	3
5.1 Information modelling conventions .....	3
6 Optical media layer management requirements .....	4
6.1 Fault management .....	6
6.2 Configuration management .....	6
6.3 Performance management .....	8
7 Media management model for the optical media layer .....	8
7.1 High-level overview .....	8
7.2 UML model class diagram .....	10
8 UML model file for optical media layer.....	15
Appendix I – Use cases for OTSiA connection management.....	17
I.1 Scenarios of use case 1 .....	17
I.2 Scenarios of use case 2 .....	20
Appendix II – Optical media network examples .....	22
Appendix III – Model examples and analysis.....	23
III.1 Use case 1 – in-line amplifiers .....	23
III.2 Use cases 2 – Reconfigurable optical add/drop multiplexer (ROADMs) .....	24
Bibliography.....	30

## Draft Recommendation ITU-T G.876

### Management requirements and information model for the optical media network

#### Amendment 1

*Editorial note: This is a complete-text publication. Modifications introduced by this amendment are shown in revision marks relative to Recommendation ITU-T G.876 (2021).*

#### 1 Scope

This Recommendation describes the management requirements and the information model for network elements (NEs) that contain optical media layer functions defined by ITU-T equipment Recommendations based on the ITU-T G.807 architecture, e.g., [ITU-T G.798].

The management requirements are based on [ITU-T G.7710], and the information model (IM) is based on ITU-T G.7711 object classes. Being based on the common IM in [ITU-T G.7711], the information model for the optical media layer can provide consistent operation, administration, maintenance and provisioning of transport networks.

The management of the optical media layer is independent of the digital clients carried across the media network.

This first version of ITU-T G.876 provides only the optical media layer management requirements and information models for the optical transport network (OTN). Other optical media network layer uses can be added in future versions of this Recommendation.

#### 2 References

The following ITU-T Recommendations and other references contain provisions which, through reference in this text, constitute provisions of this Recommendation. At the time of publication, the editions indicated were valid. All Recommendations and other references are subject to revision; users of this Recommendation are therefore encouraged to investigate the possibility of applying the most recent edition of the Recommendations and other references listed below. A list of the currently valid ITU-T Recommendations is regularly published. The reference to a document within this Recommendation does not give it, as a stand-alone document, the status of a Recommendation.

- [ITU-T G.694.1] Recommendation ITU-T G.694.1 (2020), *Spectral grids for WDM applications: DWDM frequency grid.*
- [ITU-T G.694.2] Recommendation ITU-T G.694.2 (2003), *Spectral grids for WDM applications: CWDM wavelength grid.*
- [ITU-T G.697] Recommendation ITU-T G.697 (2016), *Optical monitoring for dense wavelength division multiplexing systems.*
- [ITU-T G.698.2] Recommendation ITU-T G.698.2 (2018), *Amplified multichannel dense wavelength division multiplexing applications with single channel optical interfaces.*

- [ITU-T G.709] [Recommendation ITU-T G.709 \(2024\), \*Interfaces for the optical transport network \(OTN\)\*.](#)
- [ITU-T G.798] Recommendation ITU-T G.798 (2023~~17~~), *Characteristics of optical transport network hierarchy equipment functional blocks*.
- [ITU-T G.805] Recommendation ITU-T G.805 (2000), *Generic functional architecture of transport networks*.
- [ITU-T G.806] Recommendation ITU-T G.806 (2012), *Characteristics of transport equipment – Description methodology and generic functionality*.
- [ITU-T G.807] Recommendation ITU-T G.807 (2020), *Generic functional architecture of the optical media network*.
- [ITU-T G.874] Recommendation ITU-T G.874 (2020), *Management aspects of optical transport network elements*.
- [ITU-T G.959.1] [Recommendation ITU-T G.959.1 \(2018\), \*Optical transport network physical layer interfaces\*.](#)
- [ITU-T G.7710] Recommendation ITU-T G.7710/Y.1701 (2020), *Common equipment management function requirements*.
- [ITU-T G.7711] Recommendation ITU-T G.7711/Y.1702 (2022~~18~~), *Generic protocol-neutral management Information Model for Transport Resources*.
- [IEEE 802.3] [IEEE Std. 802.3:2022, \*Standard for Ethernet\*.](#)

### 3 Definitions

#### 3.1 Terms defined elsewhere

This Recommendation uses the following terms defined elsewhere:

##### 3.1.1 Terms defined in [ITU-T G.805]

- adaptation
- connection

##### 3.1.2 Terms defined in [ITU-T G.806]

- atomic function.
- management point (MP)

##### 3.1.3 Terms defined in [ITU-T M.3010]

- network element (NE)

##### 3.1.4 Terms defined in [ITU-T G.694.1]

- frequency slot
- slot width

##### 3.1.5 Terms defined in [ITU-T G.959.1]

- optical tributary signal (OTSi)

##### 3.1.6 Terms defined in [ITU-T G.807]

- media channel
- media channel group (MCG)
- network media channel (NMC)

- network media channel group (NMCG)
- optical parameter monitor (OPM)
- optical supervisory channel (OSC)
- optical tributary signal assembly (OTSiA)
- optical tributary signal group (OTSiG)
- optical tributary signal group overhead (OTSiG-O)

### 3.2 Terms defined in this Recommendation

None.

## 4 Abbreviations and acronyms

This Recommendation uses the following abbreviations and acronyms:

BEI	Backward Error Indication
CTP	Connection Termination Point
FC	Forwarding Construct
FCAPS	Fault, Configuration, Accounting, Performance, Security
FD	Forwarding Domain
FDI	Forward Defect Indication
<del>FS</del>	<del>Frequency Slot</del>
ILA	In-Line Amplifier
LTP	Logical Termination Point
LP	Layer Protocol
MCC	Management Communication Channel
MCG	Media Channel Group
NMC	Network Media Channel
NMCG	Network Media Channel Group
OAM	Operation, Administration, Maintenance
OMS	Optical Multiplex Section
OMS-O	Optical Multiplex Section Overhead
OPM	Optical Parameter Monitor
OSC	Optical Supervisory Channel
OSME	Optical Signal Maintenance Entity
OTS	Optical Transmission Section
OTS-O	Optical Transmission Section Overhead
OTSi	Optical Tributary Signal
OTSiA	Optical Tributary Signal Assembly
OTSiG	Optical Tributary Signal Group
OTSiG-O	Optical Tributary Signal Group Overhead



[PMS](#) [Physical Media Section](#)

ROADM Reconfigurable Optical Add/Drop Multiplexer

TP Termination Point

TTP Trail Termination Point

## 5 Conventions

### 5.1 Information modelling conventions

#### 5.1.1 UML modelling conventions

See [ITU-T G.7711] clause 5.1.

#### 5.1.2 Model artefact lifecycle stereotypes conventions

See [ITU-T G.7711] clause 5.2.

#### 5.1.3 Forwarding entity terminology conventions

See [ITU-T G.7711] clause 5.3.

#### 5.1.4 Conditional package conventions

See [ITU-T G.7711] clause 5.4.

#### 5.1.5 Pictorial diagram conventions

See [ITU-T G.7711] clause 5.5.

## 6 Optical media layer management requirements

The management of the optical media layer is based upon the common FCAPS function requirements described in [ITU-T G.7710] and the optical media layer architecture described in [ITU-T G.807].

Figure 6-1 provides a high-level overview of the functional model used in this Recommendation as the basis to develop the management requirements for the optical media layer.

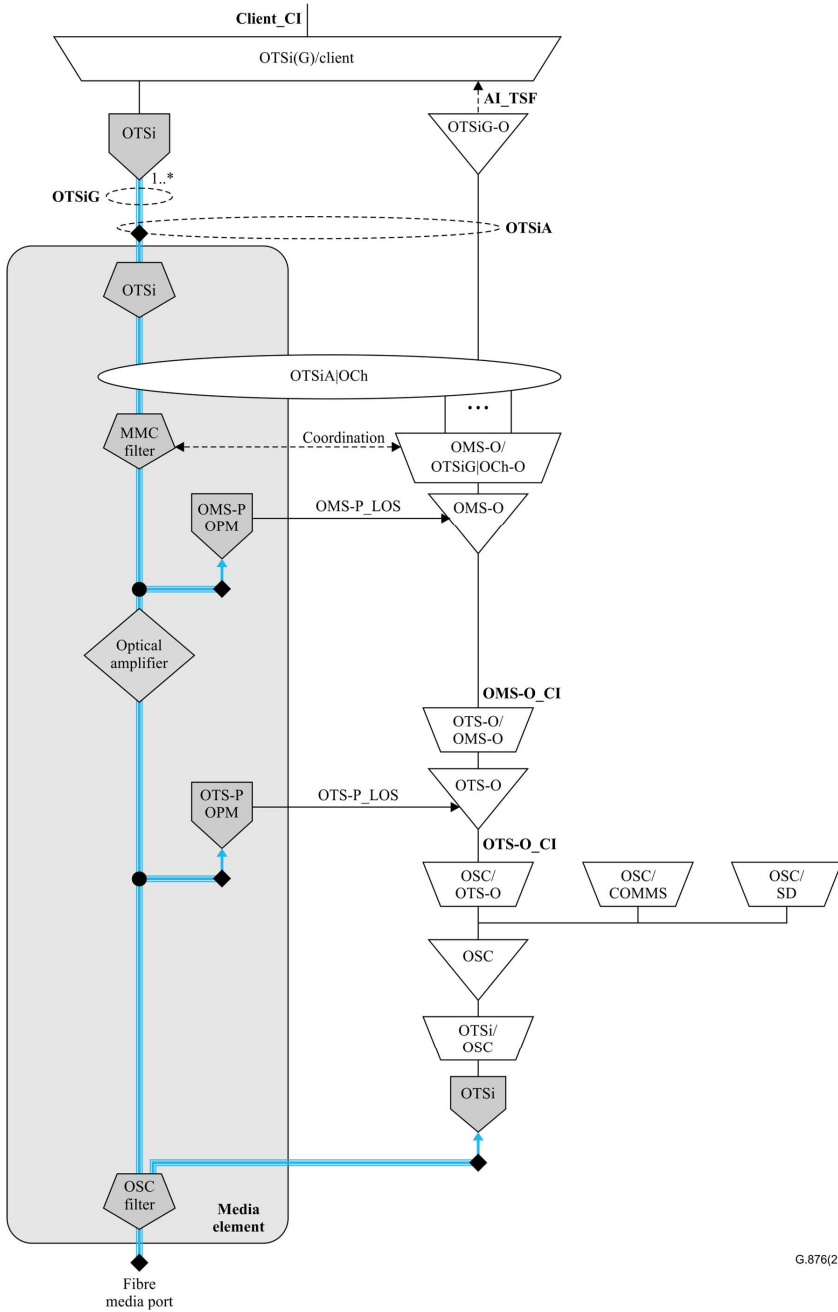

G.876(21)

Figure 6-1 – Functional model used for ITU-T G.876 management requirements of optical media layer

Figure VII.1 of [ITU-T G.798] describes the media layer functions of a NE as a media element (ME), hiding the [ITU-T G.807] media constructs. Figure 6-1 is a modification to Figure VII.1 of [ITU-T G.798] for the purpose of showing and describing the media constructs.

To clarify the media constructs inside the ME the following modifications are considered:

- The media constructs within the media element (ME) uses the [ITU-T G.807] convention to separate the optical signal from the digital information.
- The ME has been extended to also cover the OTSiA\_C to be aligned with Figure 12-5 of [ITU-T G.798] where the matrix connections are shown within the OTSiA|OCh\_C, as well as any other media layer functions that may exist in between the OTSiA\_C and the OTSi modulators/demodulators.
- The OTSi filter in Figure VII.1 in [ITU-T G.798] has been renamed as MMC (matric media channel) filter to align with the definitions in clause 12.1 of [ITU-T G.798], considering also that the configuration of the OTSiA\_C is based on the MMC frequency\_slot, independently from the number of OTSis being carried within the MMC.
- An optical OTSi filter/coupler media construct has been added between the OTSiA\_C and the OTSi modulator/demodulator. Since the OTSiA\_C configures only the MMC, this filter/coupler is needed to combine/split the different OTSis within the same MMC from/toward each OTSi modulator/demodulator. This ~~OTSi~~ filter/coupler cannot be present when the MMC carries a single OTSi.

The management requirements for the OSC, optical transmission section overhead (OTS-O), optical multiplex section overhead (OMS-O), OCh-~~O~~ and optical tributary signal ~~group assembly layer-overhead (OTSiG-O) atomic~~ functions, defined in [ITU T G.798], are defined in [ITU-T G.874].

This clause focuses on additional management requirements for the media element and the OTSi modulator and demodulators function in Figure 6-1.

## 6.1 Fault management

Common fault management requirements are defined in clause 7 of [ITU-T G.7710].

Fault management for the OTN optical media layer is provided by the OTS-O, OMS-O, OCh-~~O~~ and OTSi~~AG-O atomic-layer~~ functions defined in [ITU-T G.798].

Technology-specific fault management requirements for the optical media layer for OTN are defined in clause 7 of [ITU-T G.874]. Fault management for optical media layer are defined in clause 15.2 of [ITU-T G.807].

## 6.2 Configuration management

Common configuration management requirements are defined in clause 8 of [ITU-T G.7710].

Configuration management requirements for the OTS-O, OMS-O, OCh-~~O~~ and OTSi~~AG-O atomic-layer~~ functions, as defined from clause 9 to clause 12 in [ITU-T G.798], are defined in clause 8 of [ITU-T G.874].

Additional configuration management requirements for the media element in Figure 6-1 are explicitly described in this clause.

### 6.2.13 Configuration management for the OTSiA|OCh connections optical signals

An Configuration management for OTSiA|OCh connection include the configuration of can be used by one or more OTSi modulators/demodulators, the media channel and the OTSiG-O adaptation, termination and connection.

### **6.2.1.1 Configuration management for modulators/demodulators**

Each OTSi modulators/demodulators ~~used by the same OTSiA connection~~ needs to be configured with:

- an application identifier, which may be either a standard application code, defined in [ITU-T G.698.2] or a proprietary application identifier;
- the OTSi central frequency, which may be the same or different than the MMC central frequency.

### **6.2.1.2 Configuration management for OTSiG-O adaptation, termination and connection**

~~Configuration management of OTSiG-O subnetwork include the configuration of OSC, OTSiG-O, OMS-O, OTS-O termination, and adaptation. OMS-O and OTS-O carries the OTSiG-O for each OTSiG in the OMS and OTS, together with additional configurable or non-configurable information such as the status of the OMS and OTS, the OMS multiplex structure identifier (MSI), TTI etc. Figure 15-1 in [ITU-T G.709] shows the OTS-O, OMS-O, OCh-O and OTSiG-O information carried within the OSC. Clause 6.2.1 in this Recommendation specifies the configuration management for the OSC. Clause 8.4 and clause 8.5 in [ITU-T G.874] specified the configuration management of OTSiG-O, OMS-O, OTS-O terminations, and adaptations.~~

### **6.2.21 Configuration management for the OSC**

The OSC application identifier describes the characteristics of the OTSi modulator/demodulator as well as of the media channels which guides the OSC signal through the media element in Figure 6-1.

In case only one OSC application identifier is supported, its configuration is not required. The OSC application identifier in use could be reported for troubleshooting purposes.

### **6.2.32 Configuration management for a media channel**

The media channels used to guide the optical signals through the media element in Figure 6-1 are either pre-configured or configured during OTSiA connection setup.

In case these media channels are configured during OTSiA connection setup, they are configured within the media element in Figure 6-1 by the OMS-O/OTSiG-O|OCh\_A and by the OTSiG|OCh-O\_A atomic functions, defined in [ITU-T G.798].

#### **6.2.32.1 Frequency slot configuration**

The media channels used to guide the optical signals for one OTSiA connection can occupy one or more frequency slots ~~(FS)~~.

The configuration of a frequency slot ~~depends on the grid type of optical multiplex section (OMS) MCG, which can be to provide fixed /flexi-grid connections~~ encompasses the following attributes:

~~Grid type: for a specified optical multiplex section (OMS) MCG, the grid type can be either fixed-dwdm, fixed-cwdm or flexi-dwdm.~~

~~If the grid type is fixed cwdm, the attributes include:~~

- Channel spacing of a fixed wavelength grid, as defined in [ITU-T G.694.2];
- $n$ : a positive or negative integer including 0 to specify nominal central wavelength for a frequency slot with the formula  $1471 + n * \text{channel spacing (in nm)}$ ;

~~NOTE – The formula has been defined to produce the values provided in Table 1 of [ITU-T G.694.2] and allow a common structure for the configuration of coarse wavelength division multiplexing (CWDM) and dense wavelength division multiplexing (DWDM) frequency slots.~~

~~If the grid type is fixed dwdm, the attributes include:~~

- Channel spacing of a fixed frequency grid (e.g., 50GHz), as defined in clause 7 of [ITU-T G.694.1];
- n: a positive or negative integer including 0 to specify nominal central frequency for a frequency slot with the formula  $193.1 + n * \text{channel spacing}$  (in THz);

— If the grid type is flexi-dwdm, the attributes include:

- n: a positive or negative integer including 0 to specify nominal central frequency for a frequency slot with the formula  $193.1 + n * \text{nominal central frequency granularity}$ .
- nominal central frequency granularity: 0.00625THz is the nominal central frequency granularity defined in clause 8 of [ITU-T G.694.1];
- m: a positive integer for specifying the slot width with formula  $m * \text{slot width granularity}$  in clause 8 of [ITU-T G.694.1].
- slot width granularity: 12.5GHz is the slot width granularity defined in clause 8 of [ITU-T G.694.1].

—— Channel spacing for a specified OMS MCG:

• Using a fixed-dwdm grid, it represents the channel spacing of a fixed frequency grid (e.g., 50 GHz), as defined in clause 6 of [ITU-T G.694.1];

• Using a fixed-cwdm grid, it represents the channel spacing of a fixed wavelength grid (e.g., 20 nm), as defined in [ITU-T G.694.2];

• Using a flexi-dwdm grid, it represents the channel spacing of a flexible frequency grid (e.g., 6.25 GHz), as defined in clause 7 of [ITU-T G.694.1];

—— Slot width granularity: for a specified OMS MCG using a flexi-dwdm grid (e.g., 12.5 GHz), as defined in clause 7 of [ITU-T G.694.1];

—— n: a positive or negative integer including 0, used to specify the OTSi nominal central frequency or wavelength for a frequency slot:

• for fixed-dwdm grids, the nominal central frequency is  $193.1 + n * \text{channel spacing}$  (in THz), as defined in clause 6 of [ITU-T G.694.1];

• for fixed-cwdm grids, the nominal central wavelength is  $1471 + n * \text{channel spacing}$  (in nm), as defined in [ITU-T G.694.2];

—— NOTE — The formula has been defined to produce the values provided in Table 1 of [ITU-T G.694.2] as well as to allow a common structure for the configuration of coarse wavelength division multiplexing (CWDM) and dense wavelength division multiplexing (DWDM) frequency slots.

• for flexi-dwdm grids, the nominal central wavelength is  $193.1 + n * \text{channel spacing}$  (in THz), as defined in clause 7 of [ITU-T G.694.1]

—— m: a positive integer used to specify the slot width for a frequency slot within a flexi-dwdm grid:

• the slot width is  $m * \text{the slot width granularity}$  (in GHz).

### 6.3 Performance management

Common performance management requirements are defined in clause 10 of [ITU-T G.7710].

Performance management requirements for the OTS-O, OMS-O, OCh-O and OTSiAG-O atomic layer functions, defined in [ITU-T G.798], are defined in clause 10 of [ITU-T G.874].

~~Additional performance management requirements for the media element in Figure 6-1 are explicitly described in this clause.~~

The media channel does not support performance monitoring. As indicated in [ITU-T G.807], the performance of a media channel may be inferred by observing the properties of a signal in that media channel or from the digital information carried by the signal. It may be necessary to observe the signal at multiple points to determine the performance of the media channel.

The optical performance parameters ~~of signals in the media channel that~~ can be monitored are described in clause 8 of [ITU-T G.697].

The performance of a media channel group (MCG) may be inferred from the digital information being carried by an OTSiG in that media channel group (e.g., BIP or pre-FEC errors). The pre-forward error correction (FEC), backward error ~~indication-ratio~~ (BER) detected by the decoding process in the M-AI/client CI adaptation sink function, as defined in clause 10 of [ITU-T G.807], is an indicator of the quality of the received signals. Pre-FEC degradation could indicate both linear and non-linear distortions to the signals accumulated along the optical media channel.

NOTE – As described in [ITU-T G.807], the encoding process in the M-AI/client CI adaptation may include the computation and insertion of a forward error correction (FEC) code. Further details of the M-AI/client CI adaptation are described in [ITU-T G.798].

## 7 Media management model for the optical media layer and signal

### 7.1 High-level overview

Figure 7-1 provides the mapping between the object classes ~~defined in this Recommendation~~ and the functions model ~~described~~ in Figure 6-1.



From the management point of view, Figure 7-1 provides the instances to be defined in this Recommendation. They are:

- OTS TTP
- OMS CTP
- OMS TTP
- OTSiA|OCh CTP
- OTSiA|OCh TTP
- OTSiA|OCh SN/SNC (connectivity)

## 7.2 UML model class diagram

### 7.2.1 OTS TTP object class

The OTS trail termination point (TTP) object class is defined via pruning and refactoring of the [ITU-T G.7711] logical termination point (LTP) and layer protocol (LP) object classes, when the LTP has no server LTP and contains only one LP with layerProtocolName = 'OTS', terminationState = LP\_PERMANENTLY\_TERMINATED and lpDirection = 'BIDIRECTIONAL'.

Technology-specific attributes are defined within the OTS TTP Pac, as shown in Figure 7-2:



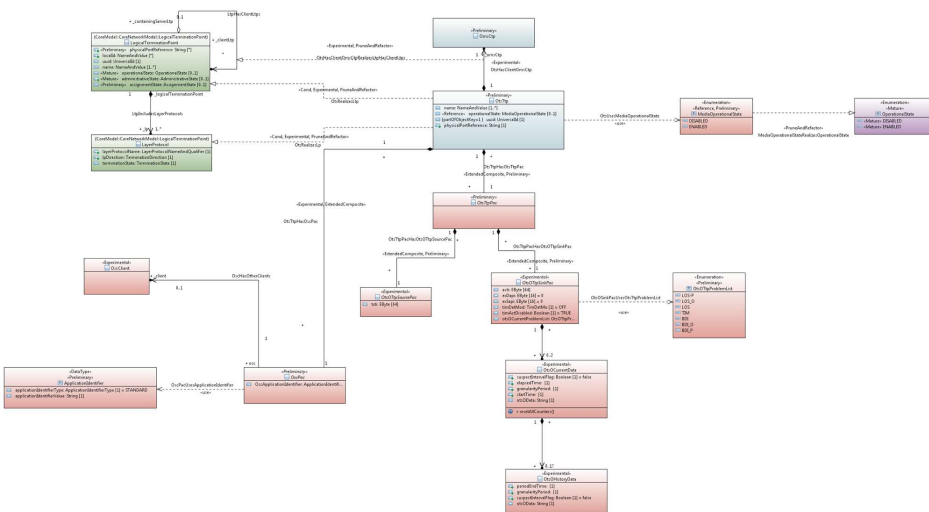
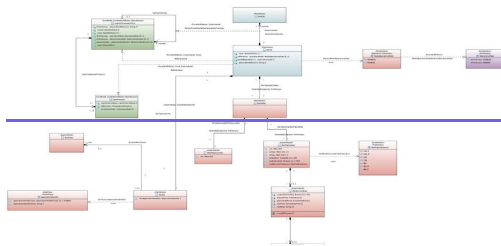

Field Code Changed

Figure 7-2 – OTS&OSC TTP UML diagram

The optical supervisory channel (OSC) is modelled as a Pac for the OTS TTP.

## 7.2.2 OMS object classes

### 7.2.2.1 OMS CTP object class

The OMS connection termination point (CTP) object class is defined via pruning and refactoring of the ITU-T G.7711 LTP and LP object classes, when LTP contains only one LP with layerProtocolName = 'OMS' and terminationState = 'LP\_CAN\_NEVER\_TERMINATE' and lpDirection = 'BIDIRECTIONAL'.

Technology-specific attributes are defined within an OMS CTP Pac, as shown in Figure 7-3:

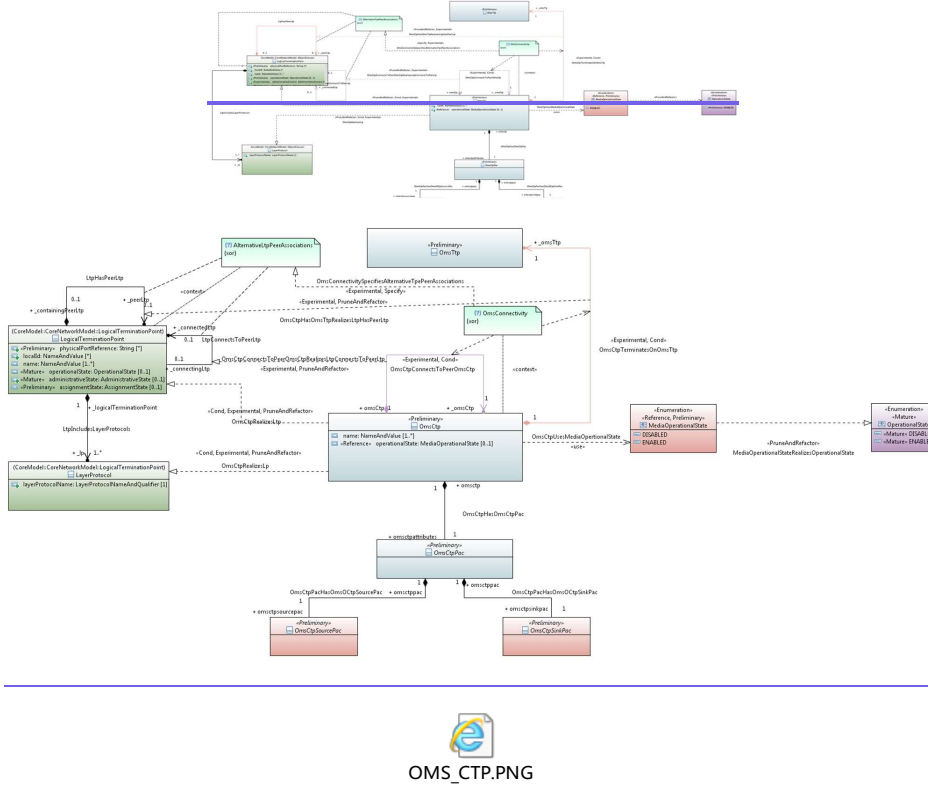

Field Code Changed

Figure 7-3 – OMS CTP UML diagram

An OMS CTP instance can have fixed connectivity either with:

- A peer OMS CTP instance (e.g., in use case 1, clause III.1 of Appendix III), which is modelled by the `OmsCtpConnectsToPeerOmsCtp` association, defined via pruning and refactoring of the [ITU-T G.7711] `LtpConnectsToPeerLtp` association.
- An OMS TTP instance (e.g., in use case 2, clause III.2 of Appendix III), which is modelled by the `OmsCtpTerminatesOnOmsTtp` association, is defined via pruning and refactoring of the [ITU-T G.7711] `LtpHasPeerLtp` association.

The alternative (XOR) constraint between these two associations is modelled by the `OmsConnectivity` constraint, defined via pruning and refactoring of the [ITU-T G.7711] `AlternativeTpePeerAssociations` constraint.

### 7.2.2.2 OMS TTP object class

The OMS TTP object class is defined via pruning and refactoring of the [ITU-T G.7711] LTP and LP object classes, when LTP has no server LTP and it contains only one LP with `layerProtocolName = 'OMS'` and `terminationState = 'LP_PERMANENTLY_TERMINATED'` and `lpDirection = 'BIDIRECTIONAL'`.

Technology-specific attributes are defined within an OMS TTP Pac, as shown in Figure 7-4:

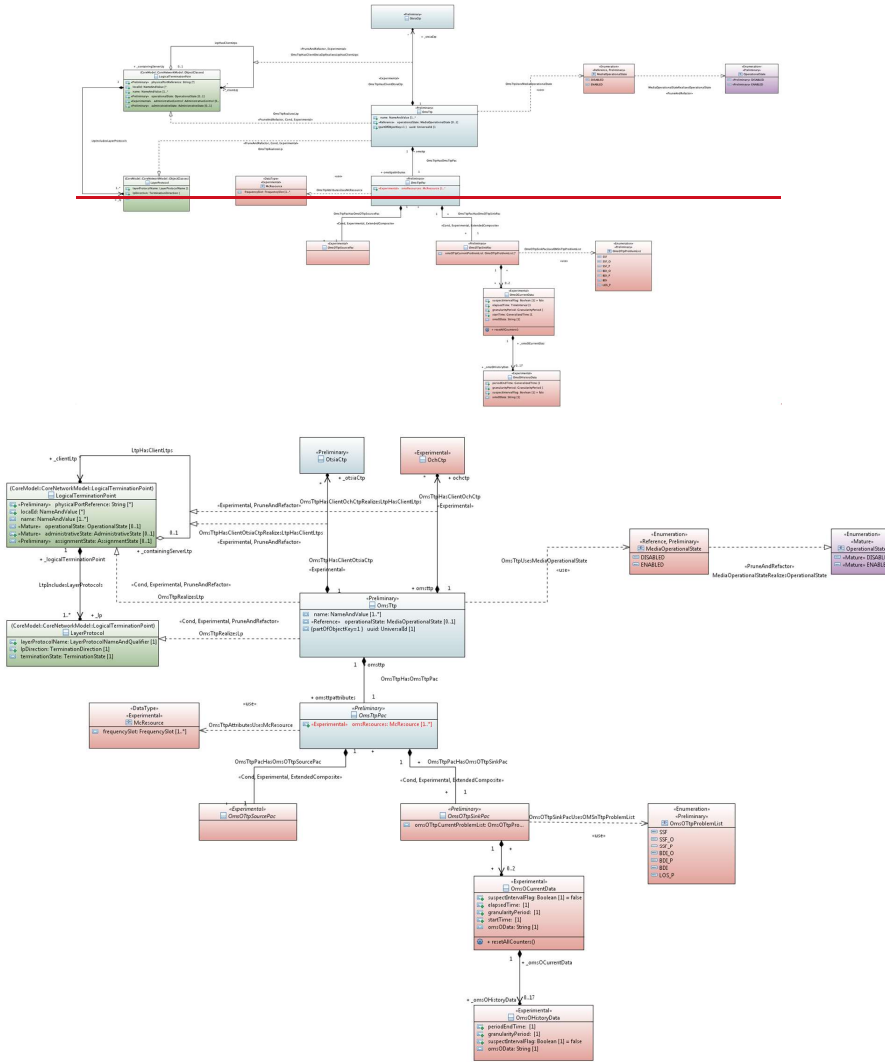

Field Code Changed

Figure 7-4 – OMS TTP UML diagram

An OMS TTP instance can support zero or more client OTSiA CTP instances (e.g., as shown in Appendix III) or OCh CTP instances. This is modelled by the OmsTtpHasClientOtsiaCtp association and OmsTtpHasClientOchCtp association, defined via pruning and refactoring of the LtpHasClientLtps association, as shown in Figure 7-4.

### 7.2.2.3 Modelling optical amplifier (OA)

The behaviour of the OA has no impact on the connectivity but on the quality of the signal.

As shown in Figure 7-5, which reproduces [the Figure 7-5 of \[ITU-T G.807\]](#), the optical amplifier belongs to the OMS MCG.

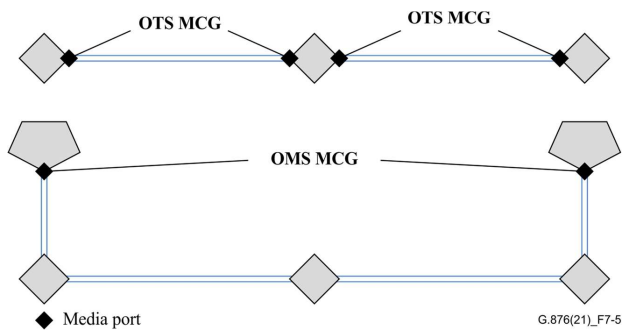

**Figure 7-5 – OTS and OMS MCGs with discrete remote optical amplifiers (Figure 7-5 of [ITU-T G.807])**

For this reason, the OA has been modelled as an "auxiliary" object class, associated with the OMS CTP and/or the OMS TTP object classes, as shown in Figure 7-6.

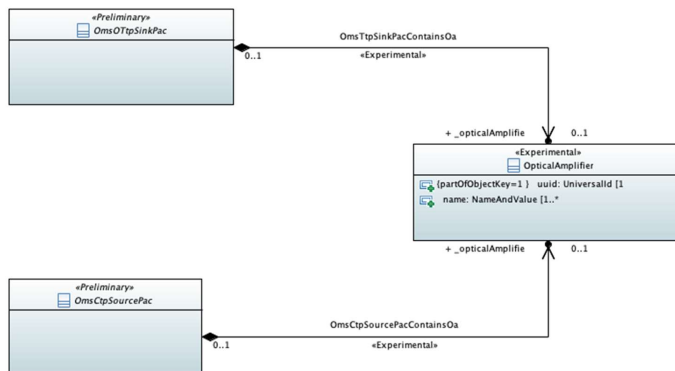

Field Code Changed

**Figure 7-6 – OA "auxiliary" UML diagram**

The associations between OA and OMS CTP/TTP are defined within the OMS CTP Source and the OMS TTP Sink Pacs since they are technology-specific associations (i.e., not defined by pruning/refactoring of any [ITU-T G.7711] association).

The OA within the OMS CTP Source amplifies the signals being transmitted to the underlying OTS while the OA within the OMS TTP Sink amplifies the signals being received by the OMS TTP.

**7.2.3 OTSiA object classes**

**7.2.3.1 OTSiA CTP object class**

The OTSiA CTP object class is defined via pruning and refactoring of the [ITU-T G.7711] LTP and LP object classes, when LTP contains only one LP with layerProtocolName = 'OTSiA' and terminationState = 'LP\_CAN\_NEVER\_TERMINATE' and lpDirection = 'BIDIRECTIONAL'.

Technology-specific attributes are defined within the OTSiA CTP Pac, as shown in Figure 7-7 below:

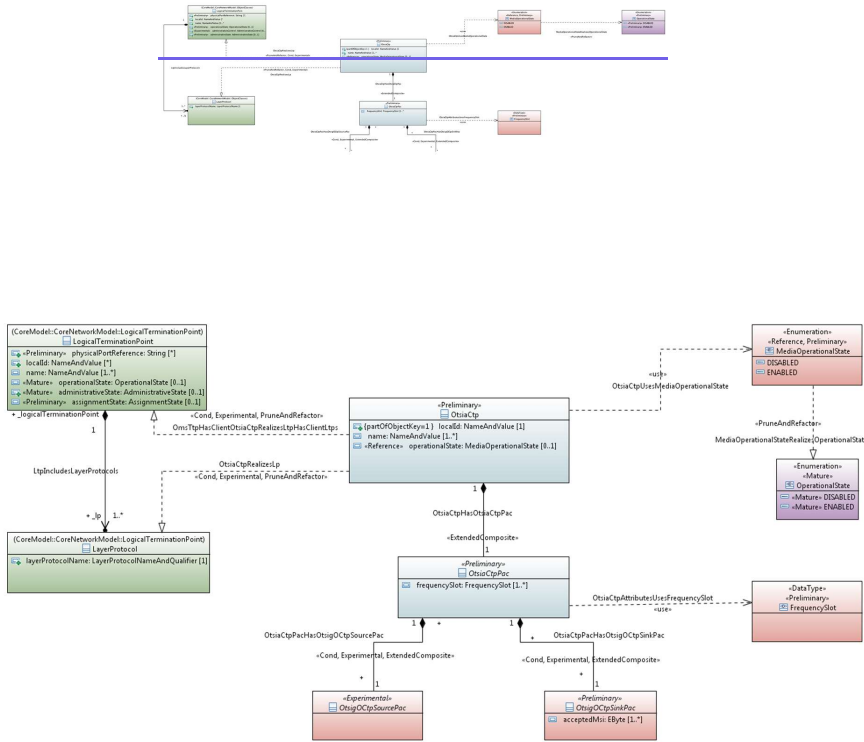

Field Code Changed

Figure 7-7 – OTSiA CTP UML diagram

The OTSiA CTP Pac object class contains a list of one or more frequency slots associated with the MMCs.

### 7.2.3.2 OTSiA TTP object class

The OTSiA TTP object class is defined via pruning and refactoring of the [ITU-T G.7711] LTP and LP object classes, when LTP has no server and LTP contains only one LP with layerProtocolName = 'OSiA' and terminationState = 'LP\_PERMANENTLY\_TERMINATED' and lpDirection = 'BIDIRECTIONAL'.

Technology-specific attributes are defined within an OMS TTP Pac, as shown in Figure 7-8:



The OTSiA TTP can also support one client OTU CTP bidirectional. This can be modelled by the OtsiaTtpHasClientOtuCtpBi association, defined via pruning and refactoring of the [ITU-T G.7711] LtpHasClientLtps association.

Since the OTU CTP bidirectional is one possible client for the OTSiA TTP and other clients can be added in the future, the OTSiA client constraints allow adding new OTSiA clients in the future versions of ITU-T G.876.

### 7.2.3.3 OTSiA SN/SNC (connectivity)

To model the OTSiA connectivity, the OTSiA SN, SNC and SNC port object classes are defined via pruning and refactoring of the [ITU-T G.7711] forwarding domain (FD), forwarding construct (FC), and FC port object classes, as shown in Figure 7-9:

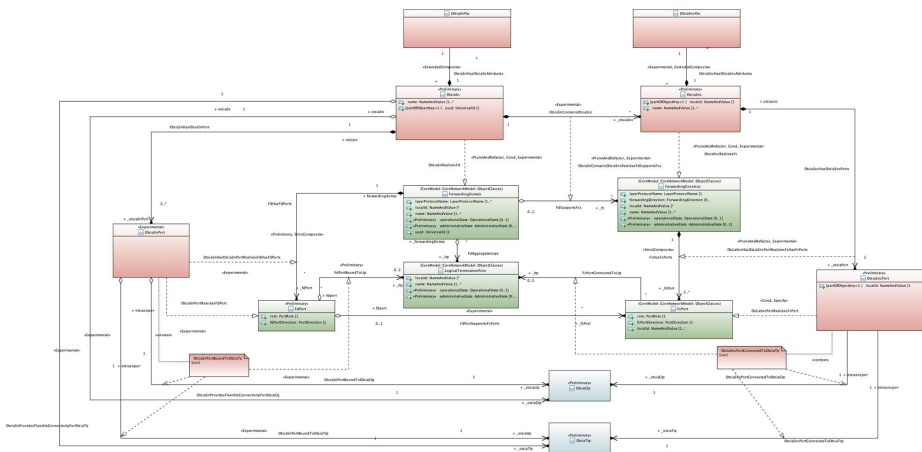

Figure 7-9 – OTSiA connectivity UML diagram

In particular:

- The OTSiA SN object class is defined via pruning and refactoring of the [ITU-T G.7711] FD object class when layerProtocolName = 'OTSiA'.
- The OTSiA SNC object class is defined via pruning and refactoring of the [ITU-T G.7711] FC object class when layerProtocolName = 'OTSiA' and forwardingDirection='BIDIRECTIONAL'.
- The OTSiA SNC port object class is defined via pruning and refactoring of the [ITU-T G.7711] FC Port object class when the FC instance is an OTSiA SNC instance.

As a consequence, the OtsiaSnContainsOtsiaSnc and the OtsiaSncHasOtsiaSncPorts associations have been defined via pruning and refactoring of, respectively, the [ITU-T G.7711] FdAggregatesLtps, FdSupportsFcs and FcHasFcPorts associations.

The relationship between the OTSiA SNC Port and the OTSiA CTP or TTP being connected is modelled by the OtsiaSncPortConnectedToOtsiaTp XOR constraint between the OtsiaSncPortConnectedToOtsiaCtp and OtsiaSncPortConnectedToOtsiaTtp associations, defined via pruning and refactoring of the [ITU-T G.7711] FcPortConnectedToLtp association.



## 7.2.4 OCh object classes

### 7.2.4.1 OCh CTP object class

The OCh CTP object class is defined via pruning and refactoring of the [ITU-T G.7711] LTP and LP object classes, when LTP contains only one LP with layerProtocolName = 'OCh' and terminationState = 'LP\_NOT\_TERMINATED'.

Technology-specific attributes are defined within the OCh CTP Pac, as shown in Figure 7-10:

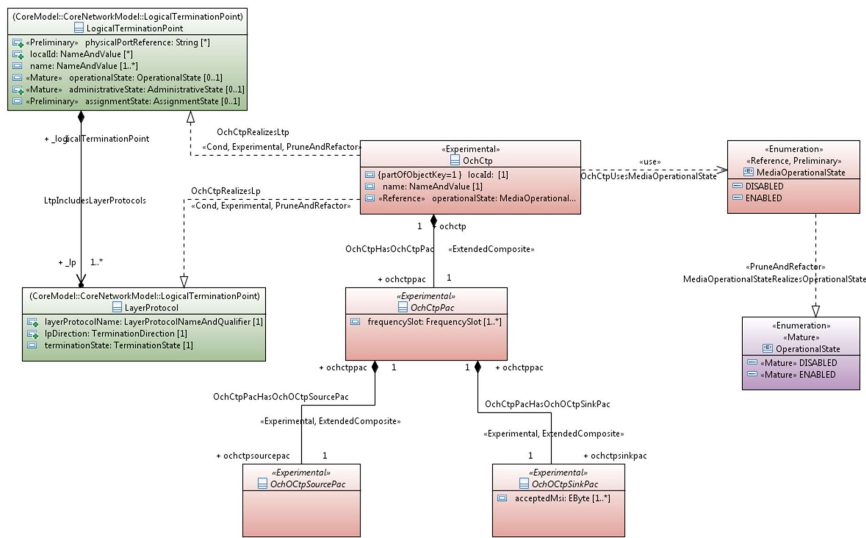

OCh\_CTP.PNG

Field Code Changed

Figure 7-10 – OCh CTP UML diagram

### 7.2.4.2 OCh TTP object class

The OCh TTP object class is defined via pruning and refactoring of the [ITU-T G.7711] LTP and LP object classes, when LTP has no server and LTP contains only one LP with layerProtocolName = 'OTSiA' and terminationState = 'LP\_TERMINATED\_BIDIRECTIONAL' and lpDirection = 'BIDIRECTIONAL'.

Technology-specific attributes are defined within an OCh TTP Pac, as shown in Figure 7-11:

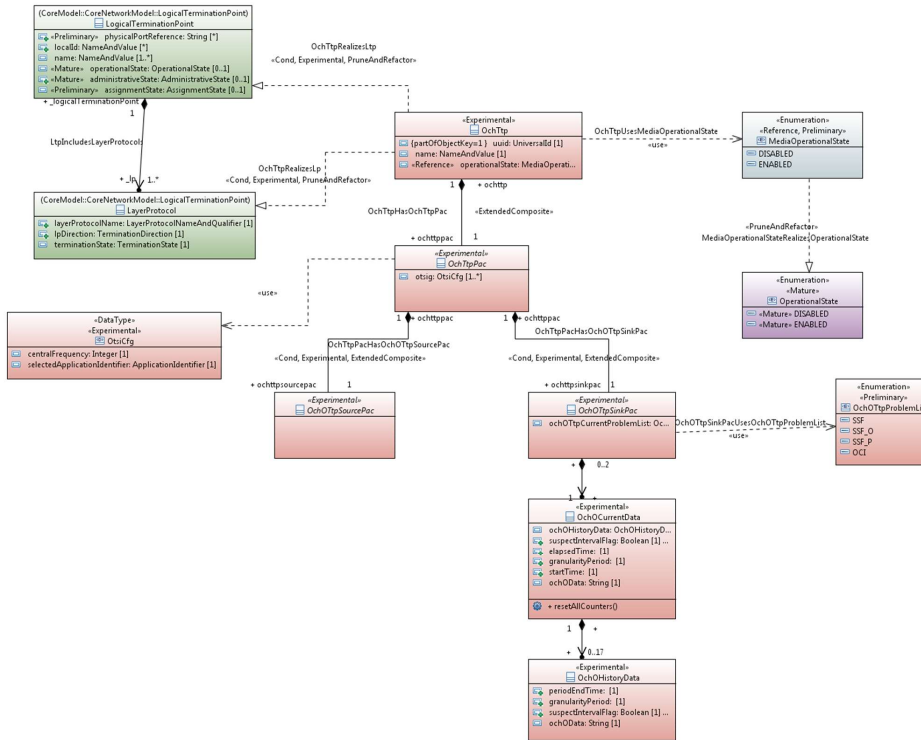

Field Code Changed

Figure 7-11 – OCh TTP UML diagram

### 7.2.4.3 OCh SN/SNC (connectivity)

To model the OCh connectivity, the OCh SN, SNC and SNC port object classes are defined via pruning and refactoring of the [ITU-T G.7111] forwarding domain (FD), forwarding construct (FC), and FC port object classes, as shown in Figure 7-12:

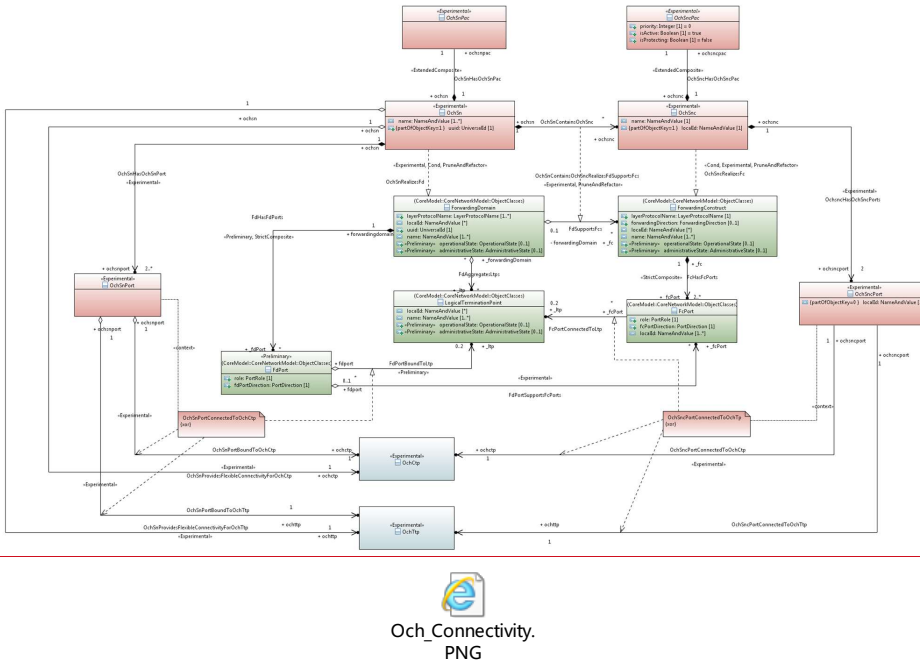

Field Code Changed

**Figure 7-12 – Och TTP UML diagram**

In particular:

- The Och SN object class is defined via pruning and refactoring of the [ITU-T G.7711] FD object class when layerProtocolName = 'Och'.
- The Och SNC object class is defined via pruning and refactoring of the [ITU-T G.7711] FC object class when layerProtocolName = 'Och' and forwardingDirection='BIDIRECTIONAL'.
- The Och SNC port object class is defined via pruning and refactoring of the [ITU-T G.7711] FC Port object class when the FC instance is an Och SNC instance.

As a consequence, the OchSnContainsOchSnc and the OchSncHasOchSncPorts associations have been defined via pruning and refactoring of, respectively, the [ITU-T G.7711] FdAggregatesLtps, FdSupportsFcs and FcHasFcPorts associations.

The relationship between the Och SNC Port and the Och CTP or TTP being connected is modelled by the OchSncPortConnectedToOchTp XOR constraint between the OchSncPortConnectedToOchCtp and OchSncPortConnectedToOchCtp associations, defined via pruning and refactoring of the [ITU-T G.7711] FcPortConnectedToLtp association.

### 7.2.5 PMS Model

The PmsTtp object class is defined via pruning and refactoring of the [ITU-T G.7711] LTP and LP object classes and PMS technology-specific attributes is defined in the PmsTtpPac and the PmsTtpSinkPac object classes.

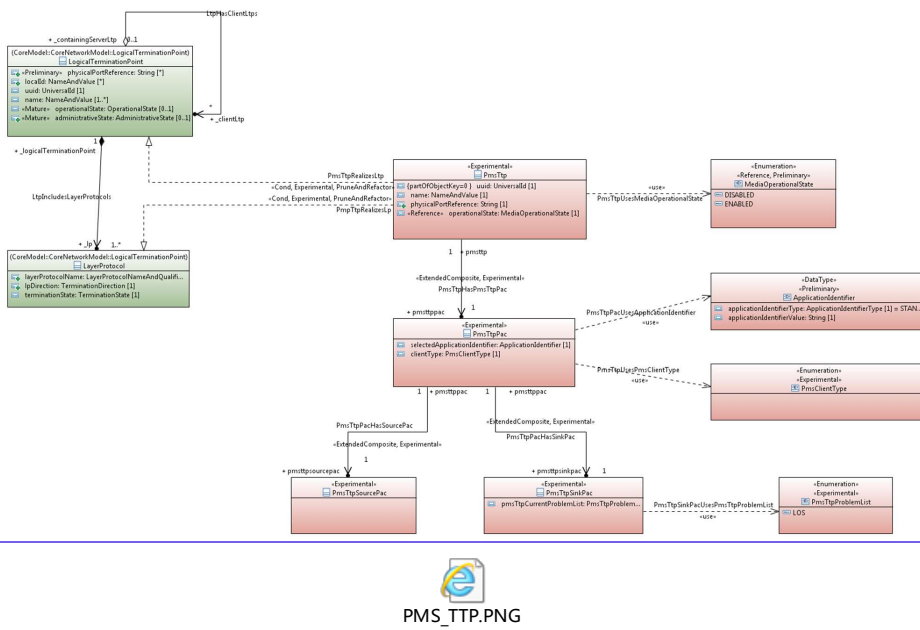
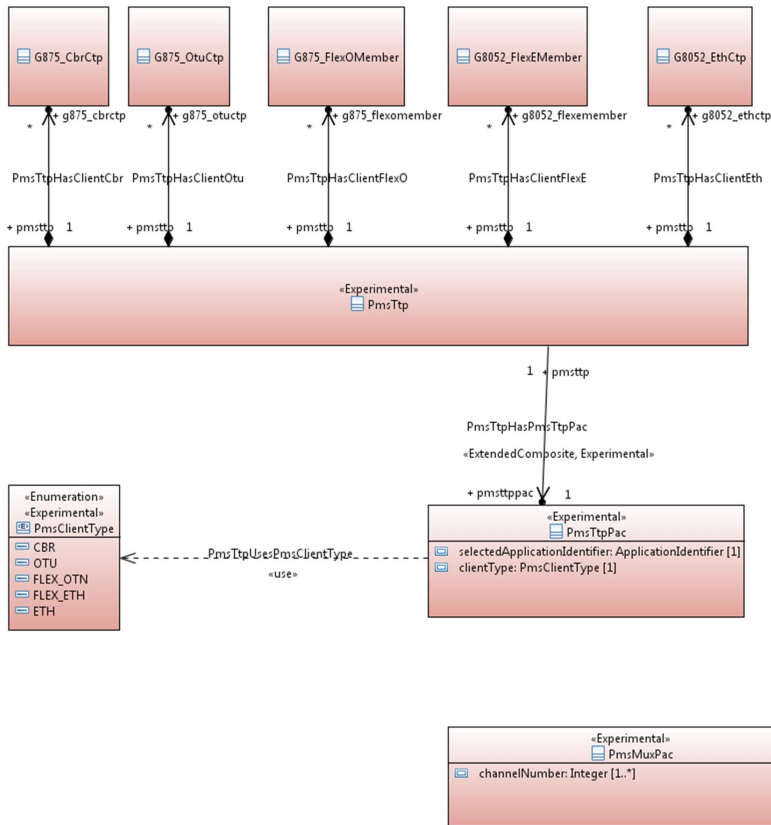

Figure 7-13 – PMS TTP UML diagram

As described in clause III.3.4 of Appendix III, when a multi-client interface is used, resources used by the client CTP (e.g., the channel numbers) need to be configured. The PmsMuxPac is defined to support this configuration.

The channelNumber attribute is defined as a signed integer. The value range of the channelNumber depends on the application identifier used by the server PmsTtp instance. The number of channels depends on the type of the client CTP instance and from the application identifier used by the server PmsTtp instance.



 PMS\_Client\_Type.  
PNG

Figure 7-14 –PMS Client Type UML diagram

## 7.2.6 Media construct model

### 7.2.6.1 Media channel object class

The MediaChannel object class is defined via pruning and refactoring of the [ITU-T G.7711] FC object classes and Media channel technology-specific attributes is defined in the MediaChannelPac object classes, as shown in Figure 7-15:

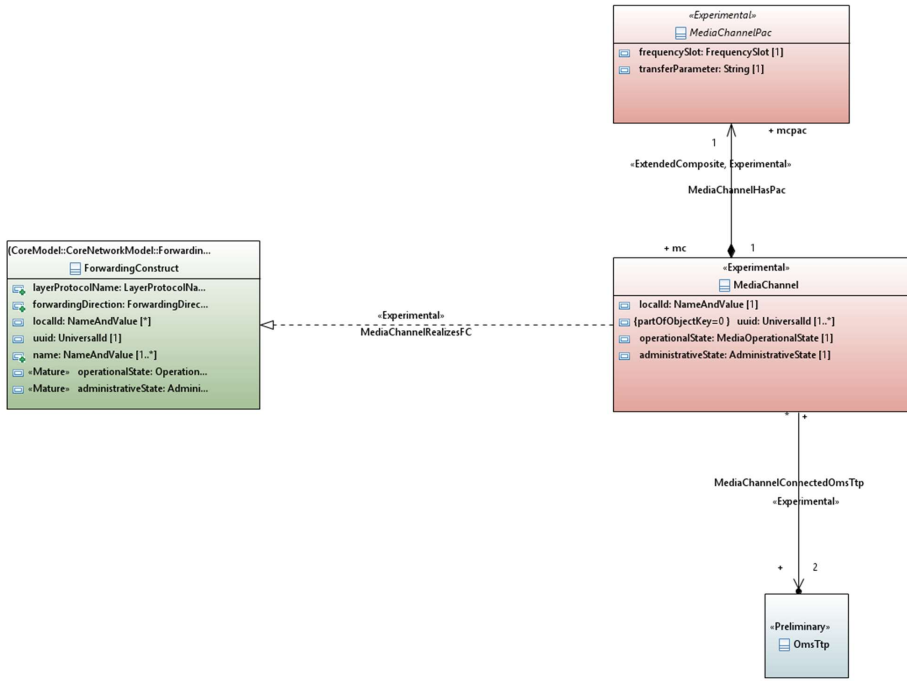

  
Media\_Channel.P  
NG

Field Code Changed

**Figure 7-15 Media Channel UML diagram**

- The media channel can be connected to OMS TTP;
- The MediaChannel object class has a MediaChannelPac which contains media channel specific information, e.g., frequency occupied and transfer parameters.

### 7.2.6.2 Media subnetwork object class

The MediaSubnetwork object class is defined via pruning and refactoring of the [ITU-T G.7111] forwarding domain (FD) object class, as shown in Figure 7-16:

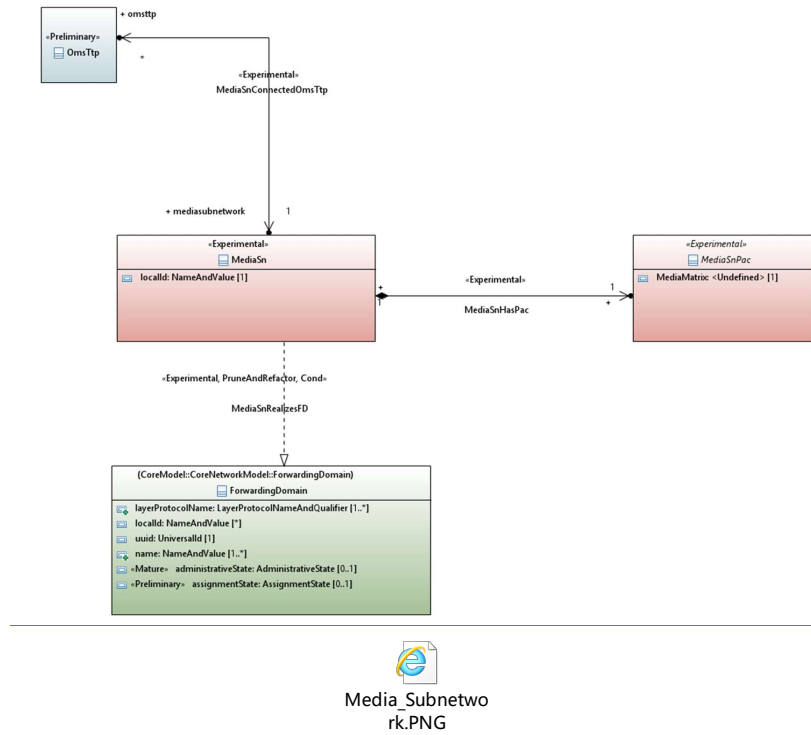

Figure 7-16 Media Subnetwork UML diagram

The MediaSn object class can exist independent of OMS TTPs.

Field Code Changed

## 8 UML model file for optical media layer

The zip file containing the ITU-T G.876 UML model developed using the Papyrus open-source modelling tool can be downloaded from: [https://www.itu.int/ITU-T/formal-language/itu-t/g/g876/2021/g876-v0.14\\_PAP.zip](https://www.itu.int/ITU-T/formal-language/itu-t/g/g876/2021/g876-v0.14_PAP.zip) is attached as:



G.876\_v1.0.5\_PA  
P.zip

Field Code Changed

This zip file contains the following folders:

- The G.876 folder, which contains the following files:
  - The Papyrus project file.
    - .project
  - The .di, .notation, and .uml files of the G.876.
    - G.876.di

- G.876.notation
- G.876.uml
- The gdITUTemplate-876.docx file, which can be used to generate the data dictionary (DD) form of the ITU-T G.876 UML model.
- The doc sub-folder, which contains the data dictionary of the ITU-T G.876 UML model.
- The UmlProfiles sub-folder, which contains the UML profiles that defines the properties of the UML artifacts.
  - The OpenModelProfile folder, which contains the .di, .notation, and uml of the *open model profile*
  - The OpenInterfaceModelProfile folder, which contains the .di, .notation, and uml of the *open model interface profile*
  - The ProfileLifecycleProfile folder, which contains the .di, .notation, and uml of the *profile lifecycle profile*
  - The ClassDiagramStyleSheet.css style sheet
- The diagrams sub-folder, which contains the PNG images of all the class diagrams.
- The G.7711 folder, which contains the [ITU-T G.7711] core model that is needed (i.e., imported) by the [ITU-T G.876] model.

NOTE 1 – If the imported model has been up-versioned or the module name has been changed, then the xmi code of the [ITU-T G.876] module will need to be updated.

To load the [ITU-T G.876] UML model into an Eclipse Papyrus workspace, follow the steps below:

- In the project explorer / Right click / Import / General / Projects from folder or archive / Next / Archive / Select the G.876 zip file / Open / Select the folders of the models to be loaded (Note 2) / Finish

NOTE 2 – If a supporting (i.e., to be imported by [ITU-T G.876]) model already exists in the workspace, do not select it for loading.

NOTE 3 – The [ITU-T G.876] UML information models and the open model profile are specified using the Papyrus open-source modelling tool. To view and further extend or modify the information model, one will need to install the open-source Eclipse software and the Papyrus tool, which are available at [b-Eclipse-Papyrus]. The installation guide for Eclipse and Papyrus can be found in [b-IISOMI 515].



## Appendix I

### Use cases for OTSiA connection management

(This appendix does not form an integral part of this Recommendation.)

The first use case of [ITU-T G.807] is to configure the OTSiA connection with the pre-configured media channels, i.e., the media channels already exist or are pre-configured in advance. The second use case of [ITU-T G.807] is to configure the OTSiA connection without the pre-configured media channels.

For the first use case of establishing an OTSiA connection, the media channels are pre-configured. Clause 10.3.1 in [ITU-T G.807] does not describe the management of the pre-configured media channels (e.g., how they are setup and removed).

This appendix assumes that the management communication channel (MCC) functions can setup pre-configured media channels in advance, without any OTSiG-O, and can later then setup OTSiA connections using these pre-configured media channels. The MCC functions can also remove pre-configured media channels when they are not used by any OTSiA connection.

This appendix describes the following MCC scenarios to support the management of the pre-configured media channels as described in the first use case of [ITU-T G.807]:

- Command: Establish pre-configured media channel
  - Pre-condition: no pre-configured media channel, no OTSiA connection
  - Post-condition: pre-configured media channel created, no OTSiA connection
- Command: Remove pre-configured media channel
  - Pre-condition: pre-configured media channel exist, no OTSiA connection
  - Post-condition: pre-configured media channel removed, no OTSiA connection

This appendix describes the following MCC scenarios to support the management of the OTSiA connections, as described in both use cases of [ITU-T G.807]:

- Command: Establish media channel+ OTSiG-O connection
  - Pre-condition: no OTSiA connections, pre-configured media channels may exist
  - Post-condition: OTSiA connection created using zero, one or more pre-configured media channels and zero, one or more media channels created
- Command: Remove media channel+ OTSiG-O connection
  - Pre-condition: OTSiA connection exist using zero, one or more pre-configured media channels and zero, one or more media channels created at connection setup
  - Post-condition: OTSiA connection removed, media channels created at connection setup removed; pre-configured media channels exist

#### I.1 Scenarios of use case 1

##### I.1.a Establish a media channel

The pre-configured media channel and the OTSiA connections are modelled as FC. The MCC function will ask to setup a pre-configured media channel in advance without any OTSiG-O.

- The operation is establishing Mc (in aEndLtpList: OTSi\_LTP, in zEndLtpList: OMS\_LTP, out MCFc: ForwardingConstruct).

Figure I.1 provides the sequence diagram describing the message sequences related to the connection establishment.

In Figure 5 in [ITU-T G.7710], the equipment management function (EMF) interacts with the atomic functions (AF) by exchanging management information (MI) across the management point (MP) reference points. In Figure I.1, the MCC interact with the EMF via the management/control interface, and then the EMF interface with the media element atomic function via the MP (management point) using the MI signals defined in [ITU-T G.798].

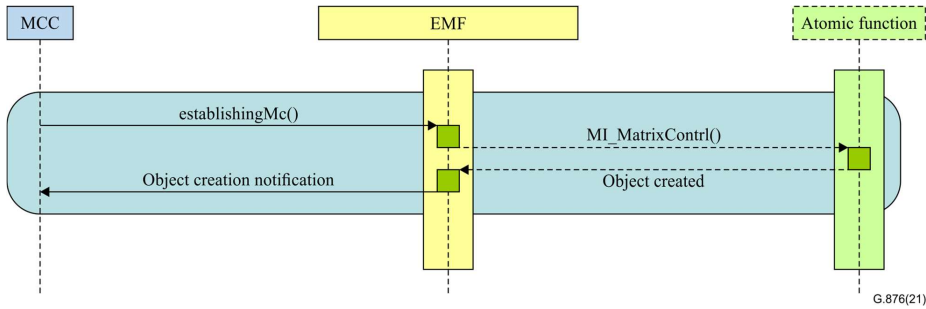
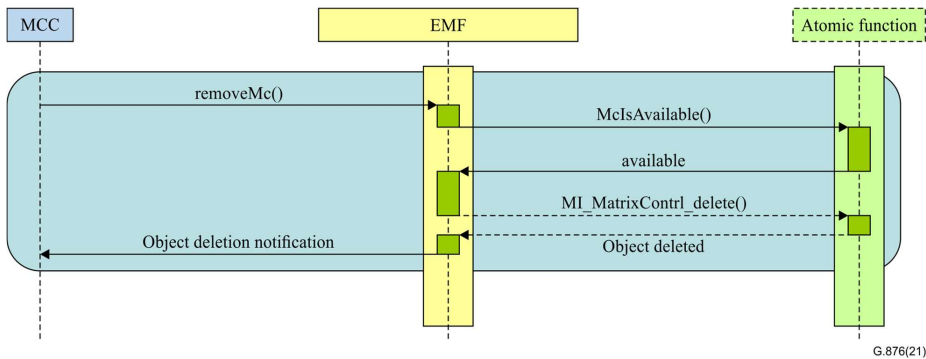

**Figure I.1 – Sequence diagram of establishing MMC**

**1.b Remove media channel**

Figure I.2 provides the sequence diagram of removing the media channel. For this scenario, MCC functions will ask to remove a pre-configured media channel.

- If the MMC is not used by any OTSiA connection, then the EMF can remove the matrix media channel (MMC).



**Figure I.2 – Sequence diagram of removing a media channel**

**1.c Establish OTSiG-O connection**

Figure I.3 provides the sequence diagram of establishing the OTSiG-O connection.

- The equipment management function (EMF) must verify that the correct ports are connected so that all members (OTSi) of the OTSiG are directed to/from the same OMS port. Therefore the operation `verifyFcPorts(in aEndLtpList: OTSiG_LTP|OMS_LTP, in zEndLtpList:OTSiG_LTP|OMS_LTP)` could be considered.
- The operation `frequencyCompatible(in FcFrequencySlots:integer[*], in OTSiFrequencySlots:integer[*])` checks the frequency slots compatibility between the filters and OTSi.

- If the media channel is available and the OTSiG-O is not available, then MCC functions could establish OTSiG-O with the operation establishingOTSiG-O(in aEndLtp: OTSiG-O\_LTP, in zEndLtp:OTSiG-O\_LTP, in OMS-O\_LTP, out OTSiG-OFc:ForwardingConstruct).

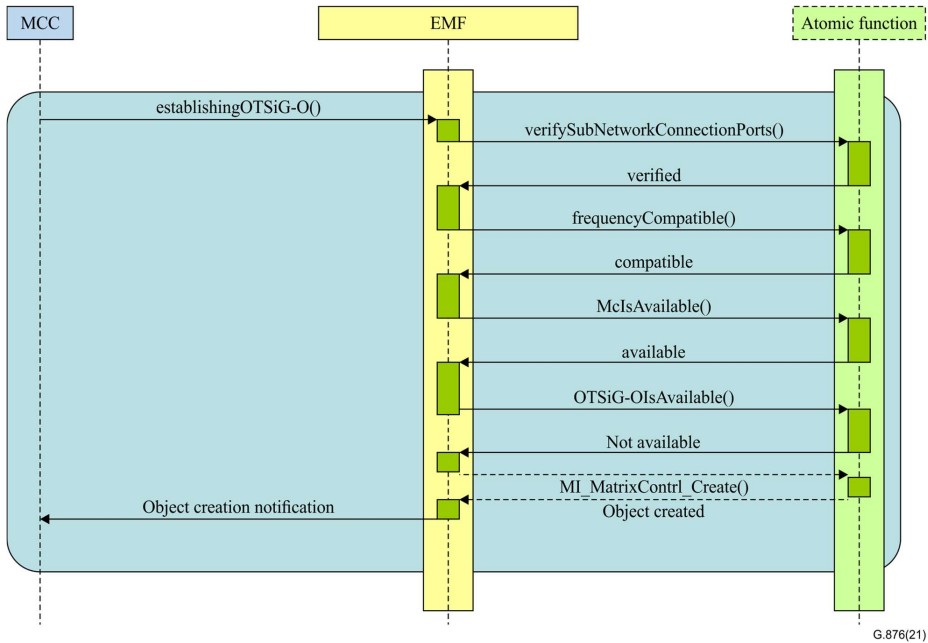

**Figure I.3 – Sequence diagram of establishing a OTSiG-O connection**

**1.d Remove OTSiG-O connection**

Figure I.4 provides the sequence diagram of removing the OTSiG-O connection.

When the MCC functions ask to remove the OTSiG-O connection, verification should be performed. If the media channel is available and the OTSiG-O connection is available, then MCC functions could remove the OTSiG-O connection.

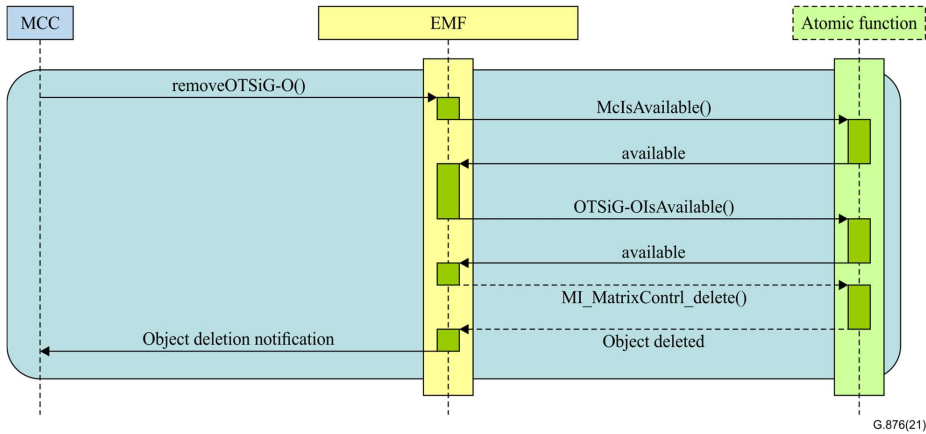

Figure I.4 – Sequence diagram of removing a OTSiG-O connection

**I.2 Scenarios of use case 2**

**2.a Establishing a media channel + OTSiG-O connection**

Figure I.5 provides the sequence diagram of establishing a media channel + OTSiG-O connection.

- The requirements of establishing a media channel and OTSiG-O connection are issued by the MCC functions.
- The EMF must verify that the correct ports are connected. It should establish the media channels described above.
- The media channel and OTSiG-O connection could be configured with the operation `establishingMcAndOTSiG-O(aEndLtpList: OTSiGO_LTP|OMS_LTP, zEndLtpList:OTSiGO_LTP|OMS_LTP, OTSiG-Ofc:ForwardingConstruct)`.

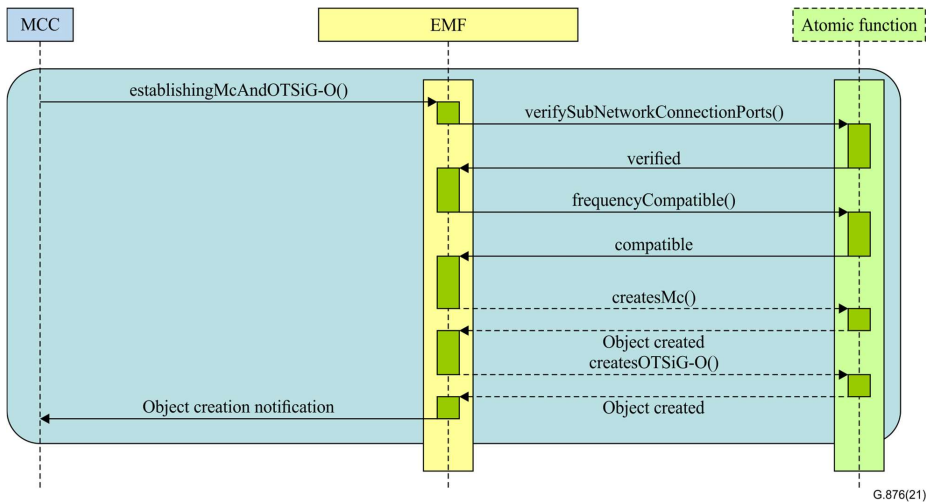
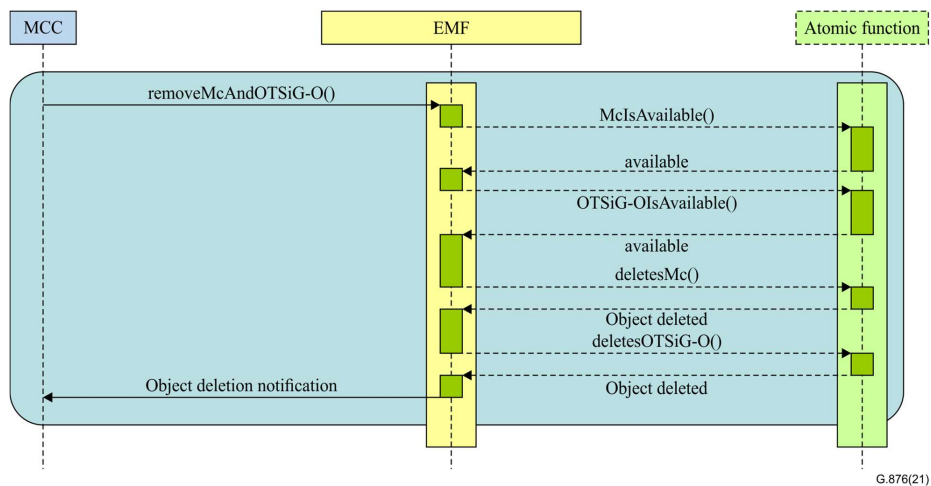

Figure I.5 – Sequence diagram of establishing a media channel + OTSiG-O connection

**2.b Remove a media channel + OTSiG-O connection**

- As shown in Figure I.6, if the MMC is available, then MCC functions could remove the media channel.
- If the OTSiG-O connection is available, then MCC functions could remove the OTSiG-O connection.



**Figure I.6 – Sequence diagram of removing a media channel + OTSiG-O connection**

## **Appendix II**

### **Optical media network examples**

(This appendix does not form an integral part of this Recommendation.)

[b-ITU-T G-sup.72] provides various examples of optical media networks by using the common information model as defined in [ITU-T G.7711].

### Appendix III

#### Model examples and analysis

(This appendix does not form an integral part of this Recommendation.)

This appendix analyses how the functional model and the managed object classes in Figure 7-1 describes different use cases.

#### III.1 Use case 1 – in-line amplifiers

Figure III.1 describes the functional model of an in-line amplifier (iLA) and its mapping to [ITU-T G.876] object classes:

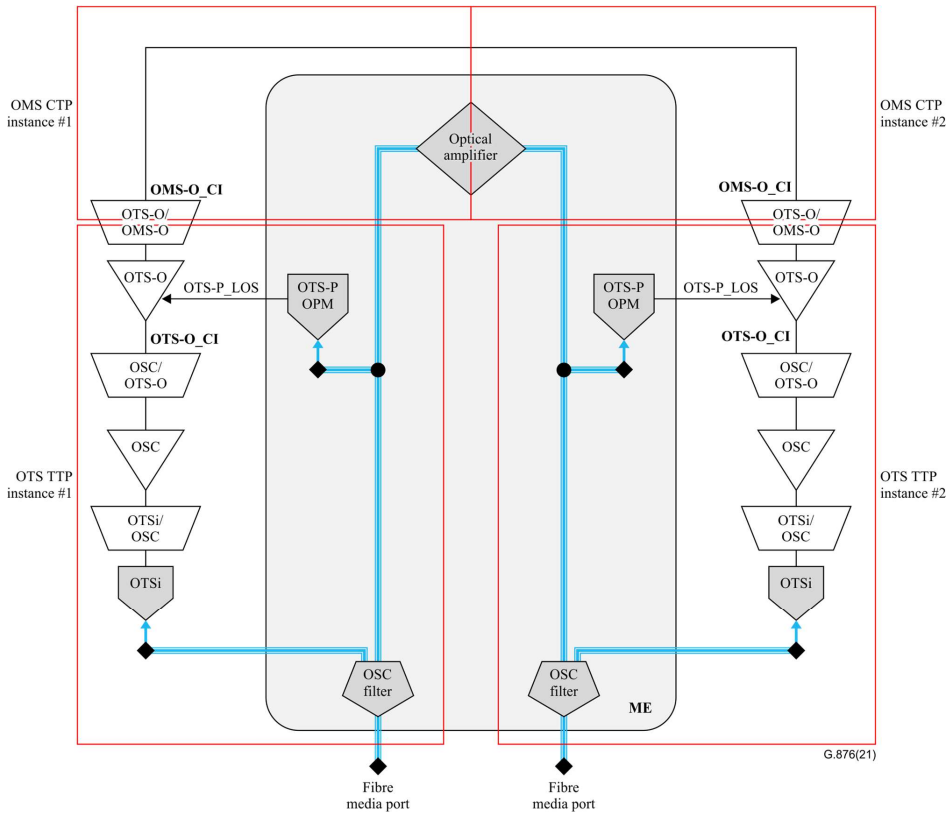

**Figure III.1 – in-line amplifier (iLA)**

An iLA has two interfaces with fixed connectivity. Therefore, it is modelled using two instances of both OTS TTP and OMS CTP object classes (one for each interface) with fixed connectivity between the two OMS CTP instances.

Since OAs are unidirectional media constructs, within an in-line amplifier (iLA), there are two OAs instances (one for each direction) which are modelled as two "auxiliary" object class instances of the two OMS CTP (source) instances, describing the amplification at each output of the iLA, as shown in Figure III.2 below:

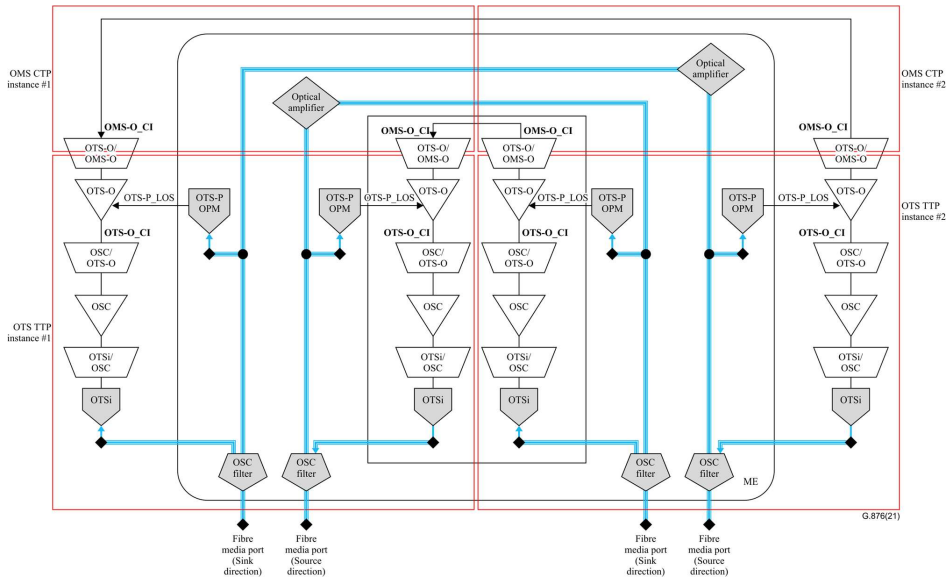

Figure III.2 – iLA ports (bidirectional view)

### III.2 Use cases 2 – Reconfigurable optical add/drop multiplexer (ROADMs)

#### III.2.1 Use case 2a – Transit ROADM

Figure III.3 describes the functional model of a transit ROADM and its mapping to [\[ITU-T G.876\]](#) object classes:



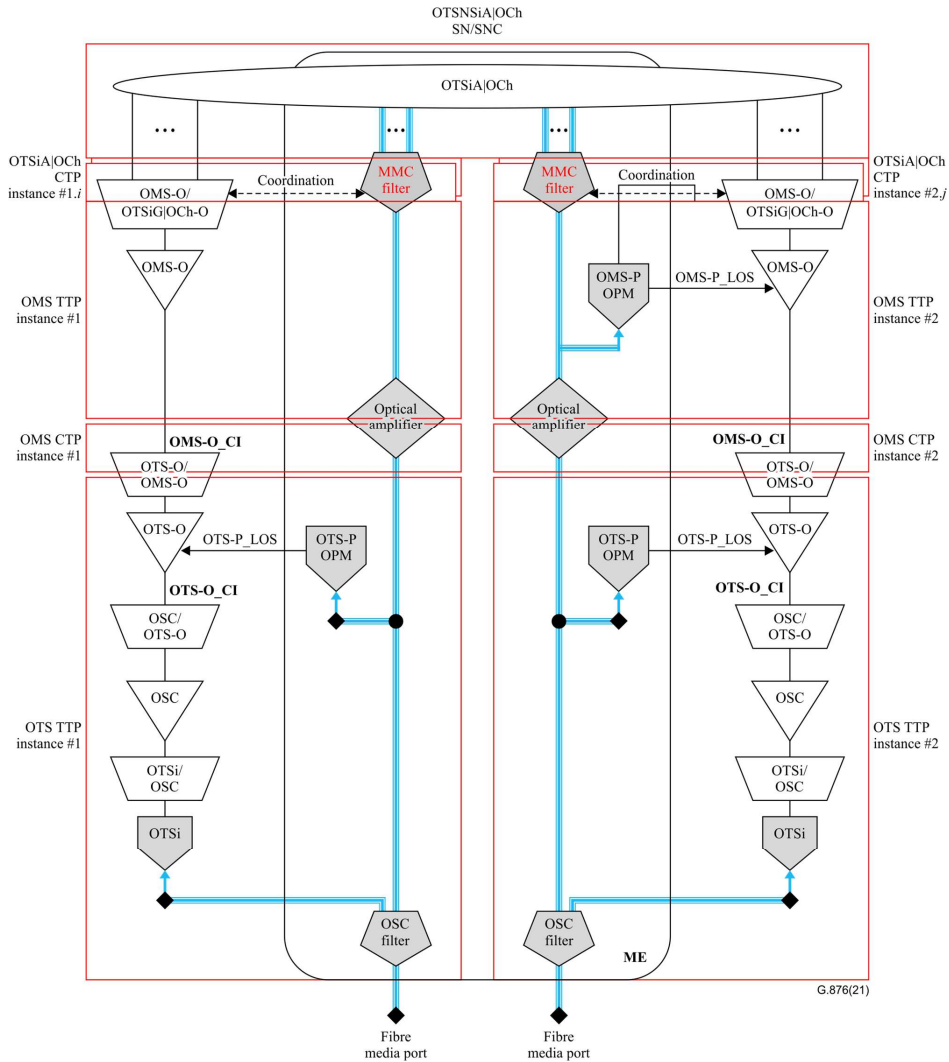

Figure III.3 – Functional model of a transit ROADM

A transit ROADM has two or more interfaces with flexible OTSiA connectivity.

Therefore, the ROADM ports are modelled using two or more instances of OTS TTP, OMS CTP, and OMS TTP object classes (one for each interface), where each OMS CTP instance has fixed connectivity with an OMS TTP instance (and vice-versa).

Since OAs are unidirectional media constructs, within a ROADM port, there are two OAs instances (one for each direction), usually referred to as a booster amplifier (in the source direction) and pre-amplifier (in the sink direction), as shown in Figure III.4 below:

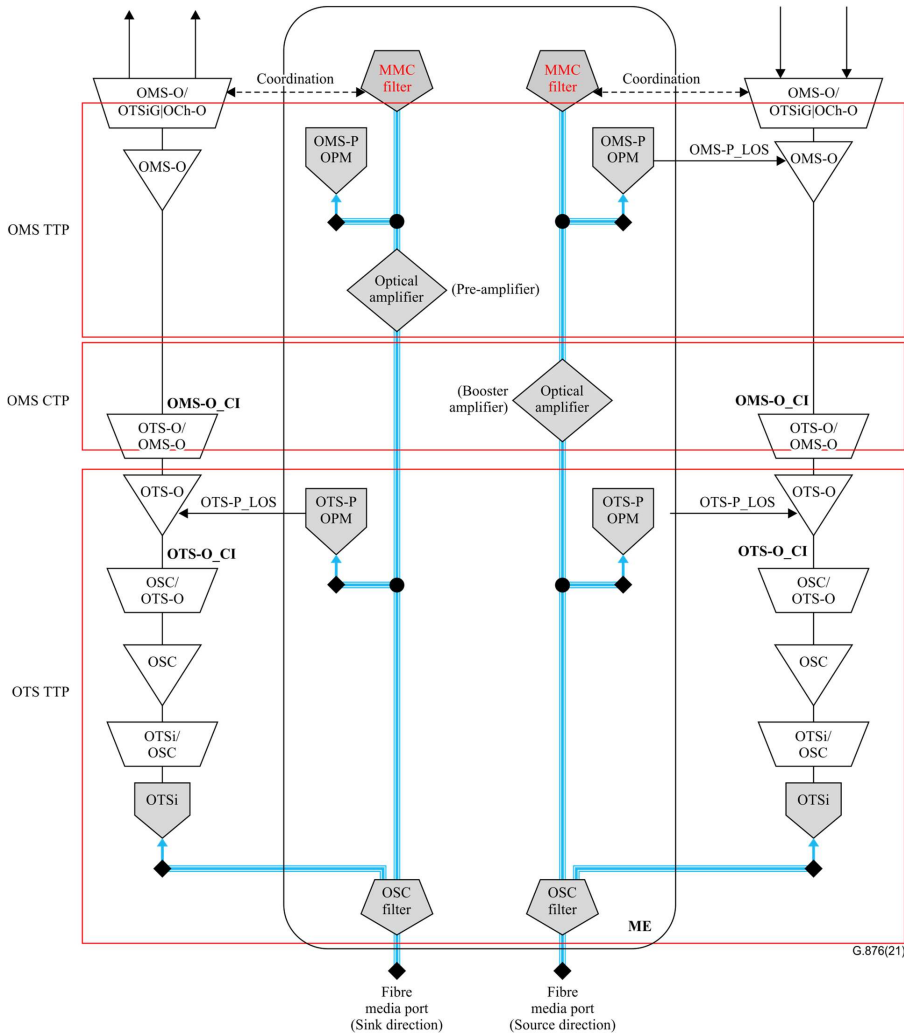

Figure III.4 – ROADM port (bidirectional view)

The pre-amplifier is modelled as an instance of the OA "auxiliary" object class of the OMS TTP (sink), which amplifies the signals being received by the OMS TTP, and the booster amplifier is modelled as an instance of the OA "auxiliary" object class instance of the OMS CTP (source), which amplifies the signals being transmitted to the underlying OTS TTP.

Each OMS TTP instance can support zero or more OTSiA CTP LTPs instances and each OTSiA CTP instance belongs to only one OTSiA connection.

The OTSiA SNC instance models the OTSiA connection being setup between the OTSiA CTP instances that belong to the same OTSiA connection.

It is worth noting that the OTSiA SNC models the matrix media channel group (MMCG) between the two OTSiA CTP instances, independently of the number of OTSi's being carried by each MMC. Each MMC filter is therefore configured with the set of frequency slots allocated to the MMCs of each OTSiA CTP instance.

### **III.2.2 Use case 2b – Edge ROADM**

Figure III.5 describes the functional model of an edge ROADM and its mapping to [\[ITU-T G.876\]](#) object classes:

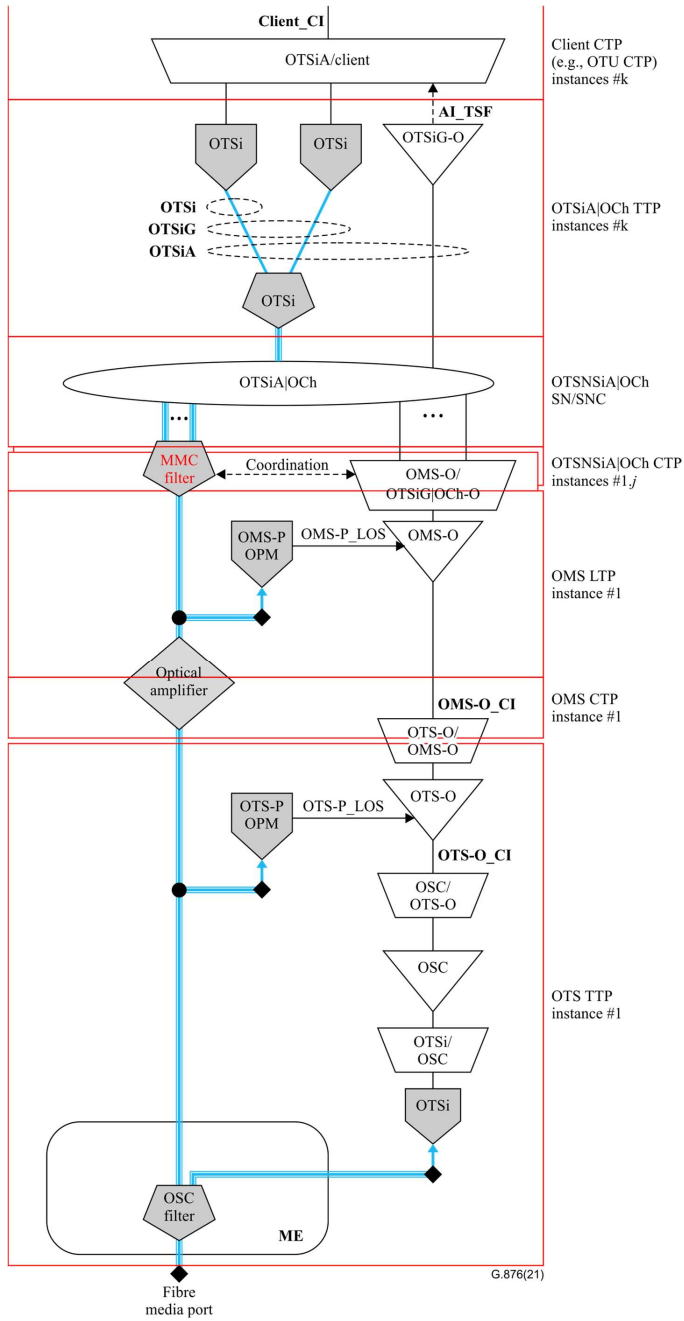

Figure III.5 – Functional model of an edge ROADM

An edge ROADM has two or more interfaces, with flexible OTSiA connectivity, and one or more client interfaces.

The ROADM ports are modelled same as in the above use case 2a (Transit ROADM).

The client interfaces are modelled by one or more OTSiA TTP and client CTP object class instances, where each OTSiA TTP instance belongs to only one OTSiA connection.

The OTSiA SNC instance, models the OTSiA connection, being setup between an OTSiA CTP instance and an OTSiA TTP instance that belong to the same OTSiA connection.

The OTSiA SNC models the matrix media channel group (MMCG) between the OTSiA CTP and OTSiA TTP instances, independently on the number of OTSis being carried by each MMC.

It is worth noting that the same ROADM can behave as a transit ROADM for some OTSiA connections and as an edge ROADM for other OTSiA connections: this flexibility is managed by proper configuration of each OTSiA SNC instances.

The management of the OTSis is only within the scope of the OTSiA TTP object class.

The media constructs within the ME portion managed by the OTSiA TTP instance can optionally contain an OTSi filter: this filter is not present if the MMC carries only one OTSi or the OTSi demodulator is not a coherent demodulator. The configuration of the OTSi filter, if present, can be done by the EMF based on the MMC configuration (derived from the configuration of the associated OTSiA SNC and OTSiA CTP instances) and of the OTSis configuration of the OTSiA TTP instance.

### **III.3 Use cases 3 – Point-to-point interfaces**

[The OTSiA and OCh object classes are defined to model the optical networking interfaces, as defined in clause 8.3 of \[ITU-T G.709\].](#)

[This appendix analyses the management of the point-to-point interfaces.](#)

#### **III.3.1 Use Case 3a – Single-carrier, single-client, single-fibre point-to-point interface**

[Figure III.6 describes a single-carrier, single-client, single-fibre point-to-point interface:](#)

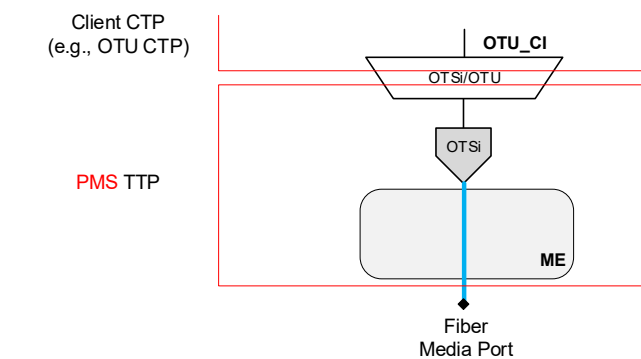

**Figure III.6 – single-carrier, single-client, single-fibre point-to-point interface**

[Figure III.6 describes, using \[ITU-T G.807\] ME and media constructs, an \[IEEE 802.3\] single-carrier interface or a single-carrier interface as shown in Figure 5-6 in \[ITU-T G.959.1\].](#)

[In case the client CTP is an ODU CTP, the functional model in Figure III.6 is aligned with the functional model of an OTN point-to-point interface type I, as shown in Figure 1-1 in \[ITU-T G.798\].](#)

Field Code Changed

In some cases, the interface supports only one [IEEE 802.3] “application identifier” (e.g., 10GBASE-LR) and only one type of client adaptation function (e.g., OTSi/ETH A). In these cases, there is nothing to configure: media constructs, within the ME, the OTSi modulator/demodulator and the OTSi/ETH A are built-in within the hardware and the [IEEE 802.3] “application identifier” (e.g., 10GBASE-LR) implicitly defines all the OTSi attributes, the client type (i.e., ETH) as well as which type of FEC is used, if any.

The cases where the interface supports only one [ITU-T G.959.1] application code (e.g., 1L1 2D2FE) and only one type of client adaptation function (e.g., OTSi/OTU A) can be modelled in the same way.

In other cases, the interface supports only one application identifier (e.g., 10GBASE-LR), but can support different types of client adaptation functions (e.g., OTSi/ETH, OTSi/CBR10G3 or OTSi/ERS10G). In these cases, the media constructs, within the ME, and the OTSi modulator/demodulator are built-in within the hardware and the ITU-T application code defines all the OTSi attributes as well as which type of FEC is used, if any, but the client type needs to be configured to allow the EMF to create the appropriate adaptation function.

There are cases where the interface can support different types of client adaptation functions (e.g., OTSi/ETH A or OTSi/OTU A) and multiple application identifiers (e.g., an [IEEE 802.3] “application identifier” or an [ITU-T G.959.1] application code), depending on the type of client adaptation function being supported. Also in these cases, the ME and the OTSi modulator/demodulator are built-in within the hardware and the application identifier still defines all the OTSi attributes as well as which type of FEC is used, if any. However, the application identifier can be different depending from the client configuration (e.g., an [IEEE 802.3] “application identifier” is used when the client is ETH).

Therefore the only configuration requirement is to configure the PMS TTP client type. In addition, the PMS TTP should report the used application identifier: this would be useful to check optical compatibility between the transmitter and the receiver. **These configurations would be specified within PMS TTP Pac.**

Since these interfaces support only one and only one client CTP, it seems that the client type can be inferred from the type of the client CTP instance created over the server PMS TTP instance with its fibre media port.

### **III.3.2 Use Case 3b – Multi-carrier, single-client, single-fibre point-to-point interface**

Figure III.7 describe as multi-carrier, single-client, single-fibre point-to-point interface:

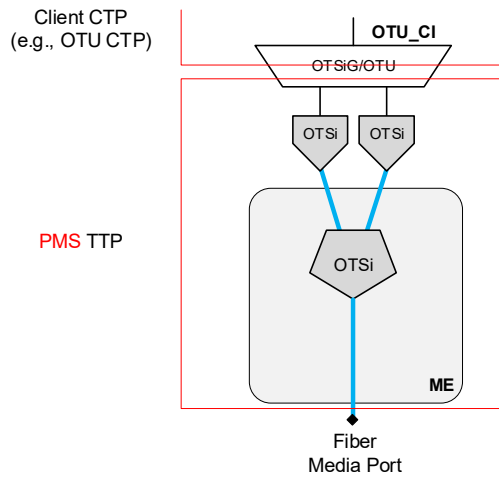

**Figure III.7 – multi-carrier, single-client, single-fibre point-to-point interface**

Figure III.7 can describe, using [ITU-T G.807] ME and media constructs, an [IEEE 802.3] multi-carrier interface or a [ITU-T G.959.1] multi-carrier interface, as shown in Figure 5-5/[ITU-T G.959.1], carrying only one client.

In case the client CTP is an ODU CTP, the functional model in Figure III.3-2 is aligned with the functional model of a multi-carrier OTN point-to-point interface type I, as shown in Figure 1-1 in [ITU-T G.798].

In case the client CTP is a FlexO CTP, the functional model in Figure 5 is aligned with the functional model of a FlexO-SR interface, as shown in Figure 1-1 in [ITU-T G.798].

In cases where the interface supports only one [IEEE 802.3] “application identifier” (e.g., 10GBASE-LR4) and only one type of client adaptation function (e.g., OTSiG/ETH\_A), the same management requirements defined for use cases 3a apply: the PMS TTP object class can just report the used [IEEE 802.3] application identifier which implicitly defines all the OTSis attributes as well as the behaviour of the OTSi filter/coupler.

The same considerations apply for interfaces supporting only one [ITU-T G.959.1] application code (e.g., 4I1-9D1F) and/or different types of client adaptation functions (e.g., OTSiG/ETH, OTSiG/CBR10G3 or OTSiG/ERS10G), as long as only one client adaptation function can be created.

These types of interfaces can be managed in the same way as those described in use case 3a above: the difference between single-carrier and multi-carrier is hidden by the “application identifier”.

### III.3.3 Use Case 3c – Multi-carrier, single-client, multi-fibre point-to-point interface

Figure III.8 describes a multi-carrier, single-client, multi-fibre point-to-point interface, where different carriers are sent over parallel fibres, instead of multiplexing multiple carriers over the same fibre:

Field Code Changed

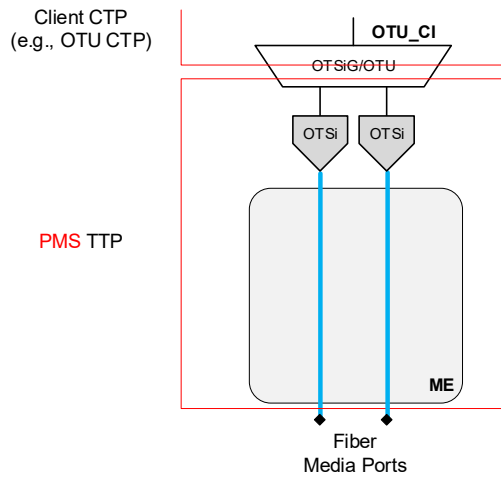

**Figure III.8 – multi-carrier, single-client, multi-fibre point-to-point interface**

An example of multi-carrier, single-client, multi-fibre point-to-point interface could be the 100GBASE-SR10, as described in TD364/GEN.

Also in this case, the media constructs within the MEs are built-in within the hardware and the IEEE 802.3 “application identifier” (e.g., 100GBASE-SR10) implicitly defines them.

Therefore, these types of interfaces can be managed in the same way as those described in use cases 3a and 3b above. The difference between single-carrier and multi-carrier is hidden within the “application identifier”. The only difference is that the PMS TTP object class should reference more than one fibre media ports.

#### **III.3.4 Use Case 3d – Multi-carrier, multi-client point-to-point interface**

There are cases where multi-carrier interfaces can support more than one client adaptation functions at the same time.

For example, it is possible to configure an [ITU-T G.959.1] multi-channel interface (e.g., P16S1-ID2) to support one OTU2 client (using four channels, not necessarily adjacent) and one STM-16 client (using one channel).

This issue is described in Figure III.9 below:

Field Code Changed



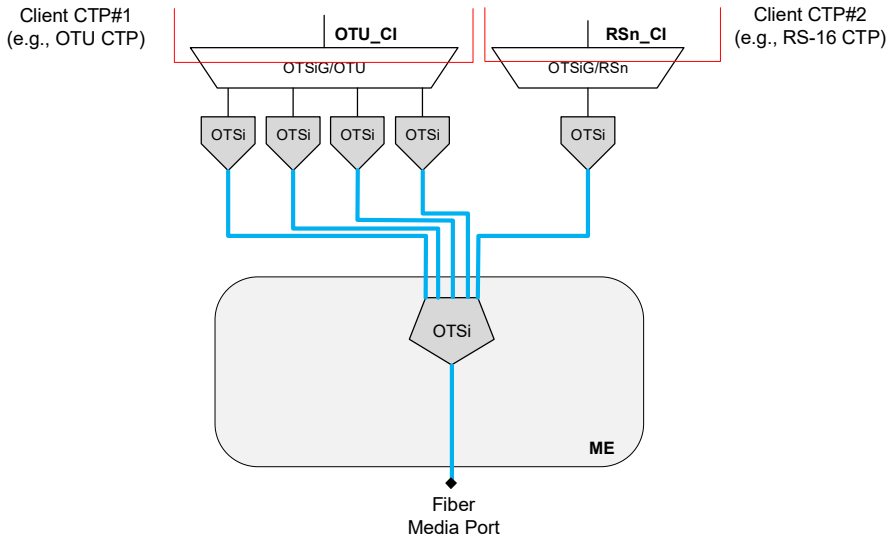

**Figure III.9 – multi-carrier, multi-client, single-fibre point-to-point interface**

In case the client CTPs are only ODU CTP, the functional model in Figure III.3-4 is aligned with the functional model of OTN point-to-point interface type II, as shown in Figure 1-1 of [ITU-T G.798].

It is worth noting that Figure III.3-3 describes a multi-carrier, multi-client, single-fibre point-to-point interface but the management considerations apply equally to multi-carrier, multi-client, multi-fibre point-to-point interfaces (if they even exist): the only difference would be on the references to the fibre media ports, as discussed for use case 3c.

### III.3.5 Use Case 3e – point-to-point interface using amplifiers

Figure III.10 describes a single-carrier, single-client, single-fibre point-to-point interface using amplifiers:

Field Code Changed

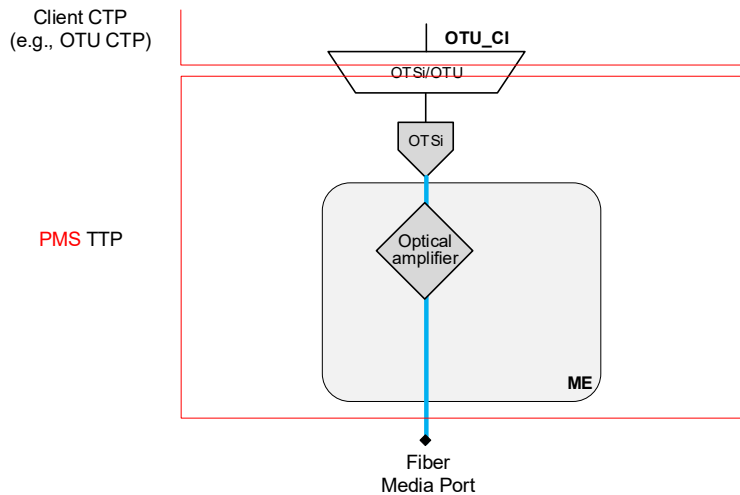

**Figure III.10 – single-fibre point-to-point interface with amplifiers**

The Figure III.10 describes a single-carrier interface but the analysis seems quite generic and applicable also to multi-carrier, single-client and multi-client, single-fibre and multi-fibre point-to-point interfaces with amplifiers. In case of multi-client interfaces, the same considerations for use case 3d are also applicable; while the considerations for use case 3c are also applicable in case of multi-fibre interface (if any exists).

Figure III.10 can describe, using [ITU-T G.807] ME and media constructs, a [ITU-T G.959.1] single-carrier interface using both pre-amplifiers and booster amplifiers (e.g., P1U1 1A2).

The Figure III.10 describes the case where the amplifier is present at both the TX and RX side, but the analysis seems quite generic and applicable also to the other cases in [ITU-T G.959.1] where the amplifier is either only at the TX side (booster amplifier) or only at the RX side (pre-amplifier).

Also in these cases, the media constructs, within the ME, including the optical amplifier(s), the OTSi modulator/demodulator are built-in within the hardware and the application identifier (e.g., an [IEEE 802.3] 100GBASE-ER4 “application identifier” or an [ITU-T G.959.1] 1U1-1B2F application code) implicitly defines also the optical amplifier attributes. Also in these cases, and there is nothing to configure other than the client type(s): the optical amplifier(s) are hidden by the “application identifier”.

Field Code Changed

### **Bibliography**

- [b-ITU-T G.959.1] Recommendation ITU-T G.959.1 (2024+8), *Optical transport network physical layer interfaces*.
- [b-ITU-T M.3010] Recommendation ITU-T M.3010 (2000), *Principles for a telecommunications management network*.
- [b-ITU-T G-Sup.72] ITU-T G-series Recommendations – Supplement 72 (2021), *Modelling consideration for optical media networks*.
- [b-Eclipse-Papyrus] Eclipse Papyrus™ modeling environment. <<https://www.eclipse.org/papyrus/>>
- [b-IISOMI 515] Informal Inter-SDO Open Model Initiative (2016), IISOMI 515 Papyrus Guidelines. <[https://openbackhaul.com/wp-content/uploads/2017/10/IISOMI\\_515\\_Papyrus\\_Guidelines\\_v1.2.pdf](https://openbackhaul.com/wp-content/uploads/2017/10/IISOMI_515_Papyrus_Guidelines_v1.2.pdf)>

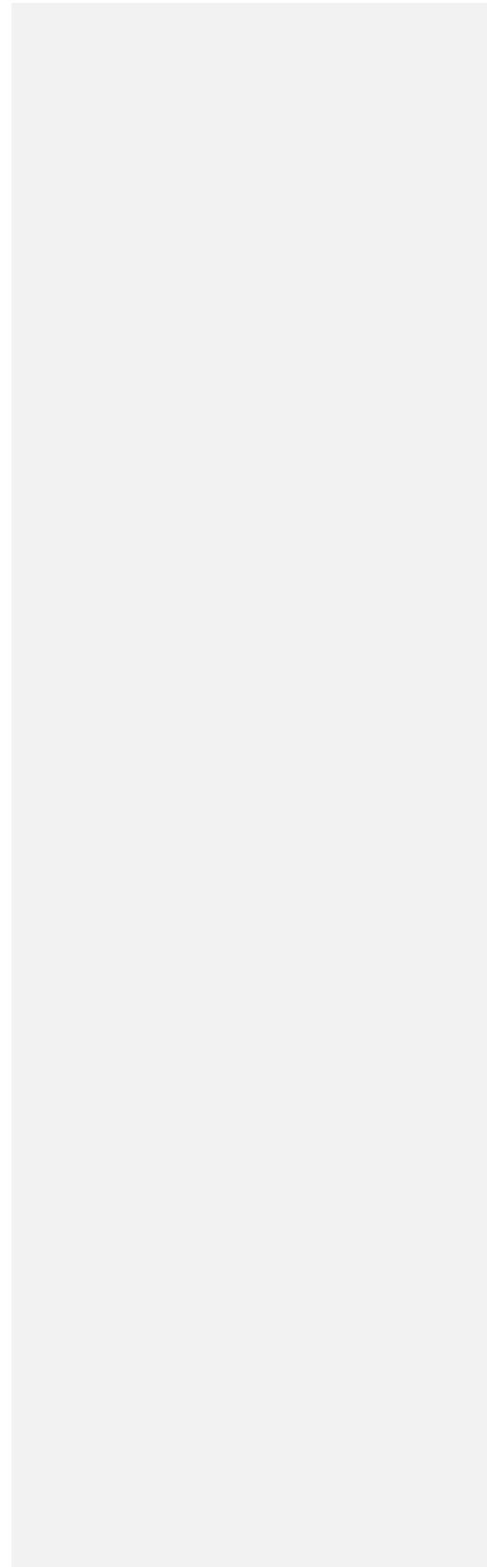

## SERIES OF ITU-T RECOMMENDATIONS

Series A	Organization of the work of ITU-T
Series D	Tariff and accounting principles and international telecommunication/ICT economic and policy issues
Series E	Overall network operation, telephone service, service operation and human factors
Series F	Non-telephone telecommunication services
<b>Series G</b>	<b>Transmission systems and media, digital systems and networks</b>
Series H	Audiovisual and multimedia systems
Series I	Integrated services digital network
Series J	Cable networks and transmission of television, sound programme and other multimedia signals
Series K	Protection against interference
Series L	Environment and ICTs, climate change, e-waste, energy efficiency; construction, installation and protection of cables and other elements of outside plant
Series M	Telecommunication management, including TMN and network maintenance
Series N	Maintenance: international sound programme and television transmission circuits
Series O	Specifications of measuring equipment
Series P	Telephone transmission quality, telephone installations, local line networks
Series Q	Switching and signalling, and associated measurements and tests
Series R	Telegraph transmission
Series S	Telegraph services terminal equipment
Series T	Terminals for telematic services
Series U	Telegraph switching
Series V	Data communication over the telephone network
Series X	Data networks, open system communications and security
Series Y	Global information infrastructure, Internet protocol aspects, next-generation networks, Internet of Things and smart cities
Series Z	Languages and general software aspects for telecommunication systems