

Draft new Recommendation ITU-T Y.3126 (ex. ITU-T Y.det-qos-rf-intwk-lan)

QoS requirements and framework of interworking capability for supporting deterministic communication services in local area network for IMT-2020 and beyond

Summary

Interworking capability is an essential function to support QoS-guaranteed data transmission across heterogeneous networks. The data transmission of deterministic communication service in local network usually involves in multiple technology domains. In order to provide efficient QoS guarantee for deterministic communication services in heterogeneous technology domains, this Recommendation defines three types of interworking capability and specifies QoS assurance requirements, framework instances and operational procedures of interworking capabilities, based on the models defined in [ITU-T Y.3121].

Keywords

deterministic communication service in local area network, framework instances, interworking capability, operational procedures, QoS assurance requirements

Table of Contents

1	Scope	3
2	References	3
3	Definitions	3
	3.1 Terms defined elsewhere	3
	3.2 Terms defined in this Recommendation	4
4	Abbreviations and acronyms	4
5	Conventions	5
6	Overview	5
7	Types of interworking capability	6
8	QoS assurance requirements of interworking capability	6
9	Instances of framework for interworking capabilities	7
	9.1 Frame instance for A2A interworking capability	7
	9.2 Framework instance for U2T interworking capability	8
	9.3 Framework instance for T2T interworking capability	8
	9.3.1 Centralized mode	8
	9.3.2 Distributed mode	9
10	Operational procedures of interworking capability	10
	10.1 QoS negotiation	10
	10.2 QoS decomposition and mapping	11
	10.3 Data processing and forwarding	12
	10.3.1 Procedure with distributed T2T interworking mode	12
	10.3.2 Procedure with centralized T2T interworking mode	13
	Appendix I	15
	Bibliography	17

Draft new Recommendation ITU-T Y.3126 (ex. ITU-T Y.det-qos-rf-intwk-lan)

QoS requirements and framework of interworking capability for supporting deterministic communication services in local area network for IMT-2020 and beyond

1 Scope

Based on the models defined in [ITU-T Y.3121], this Recommendation specifies the following aspects as a scope to support deterministic communication service across heterogeneous technology domains in a local area network.

- Types of interworking capability
- QoS assurance requirements
- Instances of framework
- Operational procedures

Detailed QoS assurance protocols and schemes of each technology domain are out of the scope of this Recommendation.

2 References

The following ITU-T Recommendations and other references contain provisions which, through reference in this text, constitute provisions of this Recommendation. At the time of publication, the editions indicated were valid. All Recommendations and other references are subject to revision; users of this Recommendation are therefore encouraged to investigate the possibility of applying the most recent edition of the Recommendations and other references listed below. A list of the currently valid ITU-T Recommendations is regularly published. The reference to a document within this Recommendation does not give it, as a stand-alone document, the status of a Recommendation.

[ITU-R M.1645] Recommendation ITU-R M.1645 (06/2003), *Framework and overall objectives of the future development of IMT-2000 and systems beyond IMT-2000*.

[ITU-T E.800] Recommendation ITU-T E.800 (09/2008), *Definitions of terms related to quality of service*.

[ITU-T Y.3121] Recommendation ITU-T Y.3121 (01/2023), *QoS requirements and framework for supporting deterministic communication services in local area network for IMT-2020*.

3 Definitions

3.1 Terms defined elsewhere

This Recommendation uses the following terms defined elsewhere:

3.1.1 technology domain [ITU-T Y.3121]: a sub-network of a local area network adopting single physical layer and data link layer scheme, with which the devices can send and receive information without interworking module.

NOTE – The interworking module provides necessary functionalities, e.g., network interconnection, protocols translation, and broadcasting support, for interworking of heterogeneous technology domains in the local area network.

3.1.2 user device [ITU-T Y.3121]: an equipment for the starting point and ending point of a traffic, owned and operated by users.

3.1.3 local area network [b-ITU-T H.322]: A shared or switched medium, peer-to-peer communications network that broadcasts information for all stations to receive within a moderate-sized geographic area, such as a single office building or a campus. The network is generally owned, used and operated by a single organization. In the context of this Recommendation, LANs also include internetworks composed of several LANs that are interconnected by bridges or routers.

3.1.4 interworking [b-ITU-T Y.1411]: The term "interworking" is used to express interactions between networks, between end systems, or between parts thereof, with the aim of providing a functional entity capable of supporting an end-to-end communication. The interactions required to provide a functional entity rely on functions and on the means to select these functions.

NOTE – the interworking capability in this Recommendation means a series functions of “interworking” to support deterministic communication services transmission across multiple TDs.

3.2 Terms defined in this Recommendation

None.

4 Abbreviations and acronyms

This Recommendation uses the following abbreviations and acronyms:

5G	the 5th Generation mobile communication technology
A2A	Application to Application
ACK	Acknowledgement
A-IWF	Application - Interworking Function
GCL	Gate Control List
IGW	Interworking Gateway function
IM	Interworking Module
INTF	Interface
LAN	Local Area Network
NACK	Negative Acknowledgement
NC	Network Controller
N-IWFC	Network – Interworking Function in Control plane
N-IWFD	Network – Interworking Function in Data plane
PHY	Physical layer
QoS	Quality of Service
TD	Technology Domain
TSN	Time Sensitive Networking
T2T	TD to TD
U2T	User device to TD
U-IWF	User device – Interworking Function

5 Conventions

In this Recommendation:

The keywords “**is required to**” indicate a requirement which must be strictly followed and from which no deviation is permitted if conformance to this document is to be claimed.

The keywords “**is recommended**” indicate a requirement which is recommended but which is not absolutely required. Thus, this requirement need not be present to claim conformance.

The keywords “**can optionally**” and “**may**” indicate an optional requirement which is permissible, without implying any sense of being recommended. These terms are not intended to imply that the vendor’s implementation must provide the option and the feature can be optionally enabled by the network operator/service provider. Rather, it means the vendor may optionally provide the feature and still claim conformance with the specification.

6 Overview

[ITU-T Y.3121] described the QoS requirements and framework for supporting deterministic communication services in local area network from end-to-end data transmission aspect, including high-level model, three QoS groups and example operational procedures. As shown in Figure 1, the high-level model defined in [ITU-T Y.3121] mainly focuses on the interworking capability between different technology domains (TDs) with the interworking module (IM). In addition, this Recommendation specifies interworking capability of application-to-application and user device to TD to support end-to-end deterministic communication services. (depicted with green arrows in Figure 1) The detailed functions and operational procedures for three types of interworking capability are also specified in this Recommendation.

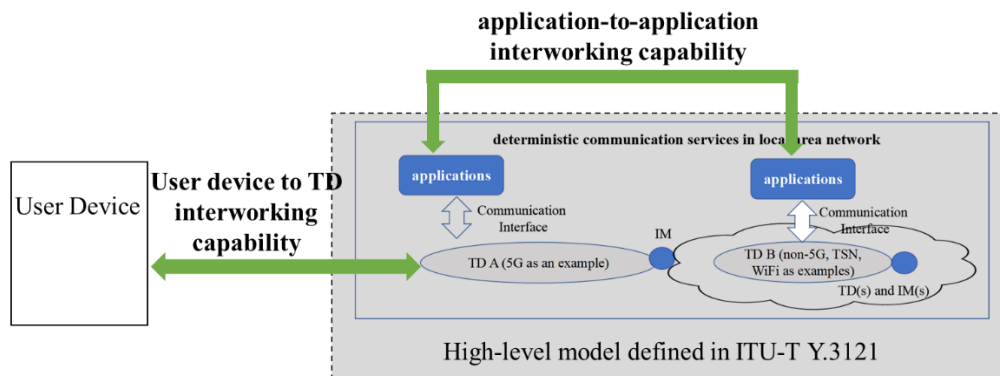

Figure 1 – Relationship of interworking capabilities between this Recommendation and [ITU-T Y.3121]

Typically, deterministic communication service crosses several different TDs in a local area network. Interworking capability is essential for QoS guarantee of end-to-end data transmission in this scenario. Lack of end-to-end interworking capability may lead to performance degradation, e.g., large end-to-end delay, bit error and packet loss, even application disconnection. Therefore, this Recommendation specifies three types of interworking capability, QoS assurance requirements, instances of framework and operational procedures for interworking capabilities.

7 Types of interworking capability

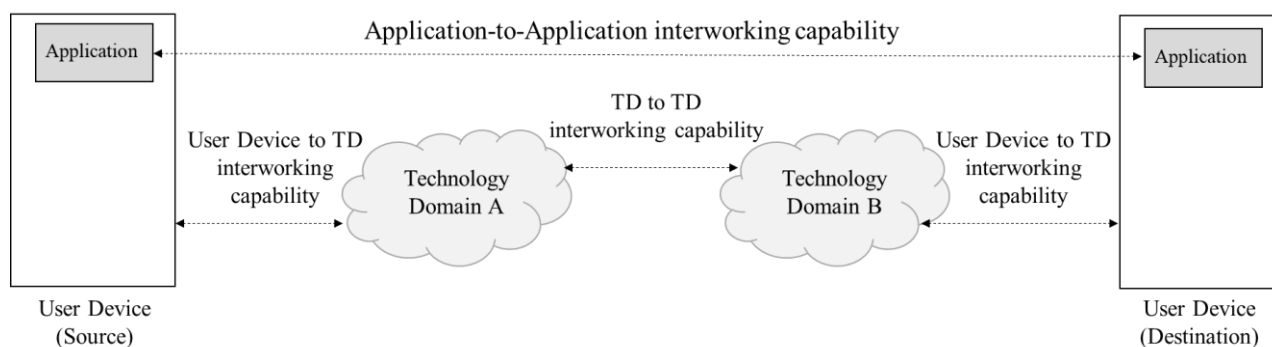

Figure 2 – Three types of interworking capability

To support deterministic communication services across heterogeneous TDs in a local area network, three types of interworking capability are defined: Application to Application (A2A), User device to TD (U2T), and TD to TD (T2T) as indicated in Figure 2.

- 1) **Application-to-application interworking capability:** the QoS interworking between applications in the source and destination user devices. The following A2A QoS metrics are negotiated: packet loss rate, packet error rate, peak/average data rate, end-to-end latency, jitter, the maximum frame size, and etc.
- 2) **User device to TD interworking capability:** the QoS interworking between a user device to a network device in a TD. Multiple mechanisms such as admission control, bandwidth allocation, scheduling, and etc. in each TD are used to support mapping from A2A QoS metrics into those of TD
- 3) **TD to TD interworking capability:** the interworking between network elements of different TDs. The interworking capability provides horizontal QoS mapping and uniform QoS assurance across TDs. Meanwhile, conversions of protocols in the user and control planes should be performed between different TDs.

8 QoS assurance requirements of interworking capability

Interworking capabilities provide a logical interface for QoS negotiation, mapping and data exchange among entities in a TD or across multiple TDs. QoS assurance requirements for three types of interworking capability are specified below.

- Requirements for A2A interworking capability
 - It is recommended to negotiate at least one of A2A QoS metrics for deterministic communication service in a local area network;
 - It is required to transmit A2A QoS metrics from a source user device to a destination user device;
 - It is required to advertise A2A QoS metrics to the related entities of each TD along the service transmission path.
- Requirements for U2T interworking capability
 - It is required that a TD requests A2A QoS metrics to the interworking user device and receives its response;

- It is required that a user device and the interworking TD identify deterministic communication flows;
 - It is required that TD maps A2A QoS metrics into internal QoS metrics;
 - It is required that a user device negotiates with network elements in the interworking TD to provide QoS assurance for deterministic communication service.
- Requirements for T2T interworking capability
 - It is required to establish a data-forwarding tunnel between TDs;
NOTE: either a newly defined data protocol or data protocol conversion can be used in the data forwarding tunnel
 - It is required to exchange QoS capabilities information (e.g., available resource, available power, channel state, buffer state and so on) between interworking TDs;
 - It is recommended to monitor the A2A QoS metrics of deterministic communication service;
 - It is required to support QoS negotiation among TDs to assure uniform QoS assurance level.

9 Instances of framework for interworking capabilities

Three instances of the framework (which is defined in [ITU-T Y.3121]) for three types of interworking capability are specified in sub-clauses 9.1, 9.2 and 9.3, respectively.

9.1 Framework instance for A2A interworking capability

Figure 3 shows the framework instance for A2A interworking capability.

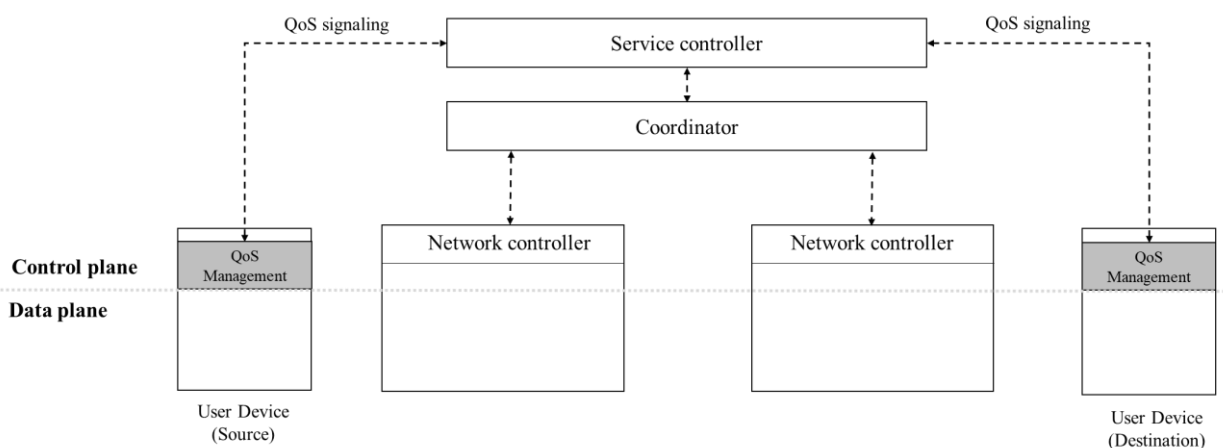

Figure 3 – Framework instance for A2A interworking capability

NOTE – the general functions of service controller, coordinator and user device are defined in [ITU-T Y.3121].

The A2A interworking capability is only related to the control plane functions of the user device and the service controller.

A-IWF is a logical interworking interface connecting the user device and the service controller, A-IWF is partly located in the control plane of the user device, and partly located in the centralized service controller.

A-IWF supports QoS signalling enabling negotiation, transmission, and advertising QoS metrics between the user device and the service controller.

9.2 Framework instance for U2T interworking capability

Figure 4 shows the framework instance for U2T interworking capability.

U-IWF is a logical QoS interworking interface between a user device and a network controller of the interworking TD, the function of U-IWF is partly located in control plane of the user device, and partly located in the network controller.

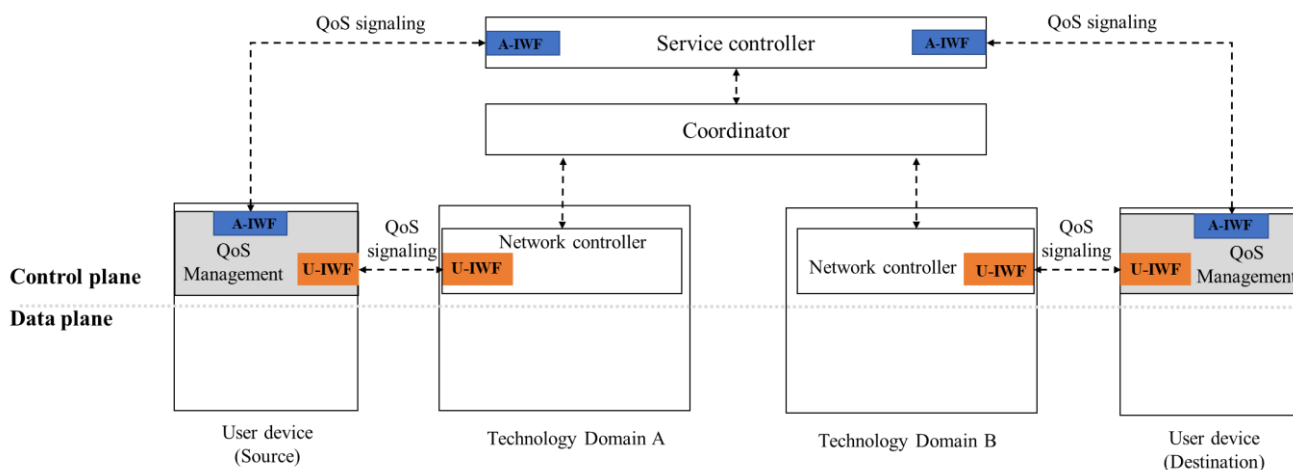

Figure 4 – Framework instance for U2T interworking capability

The U-IWF supports discovery capability of user device, QoS signaling enabling exchanges of QoS policies for call admission, resource allocation and scheduling, and QoS performance (e.g., data rate, packet error rate, jitter and so on) monitoring.

9.3 Framework instance for T2T interworking capability

T2T interworking capability involves QoS signaling in control plane and protocol conversion in data plane. The framework instance for T2T interworking capability consists of centralized mode and distributed mode.

9.3.1 Centralized mode

Figure 5 shows the framework instance for centralized mode T2T interworking capability.

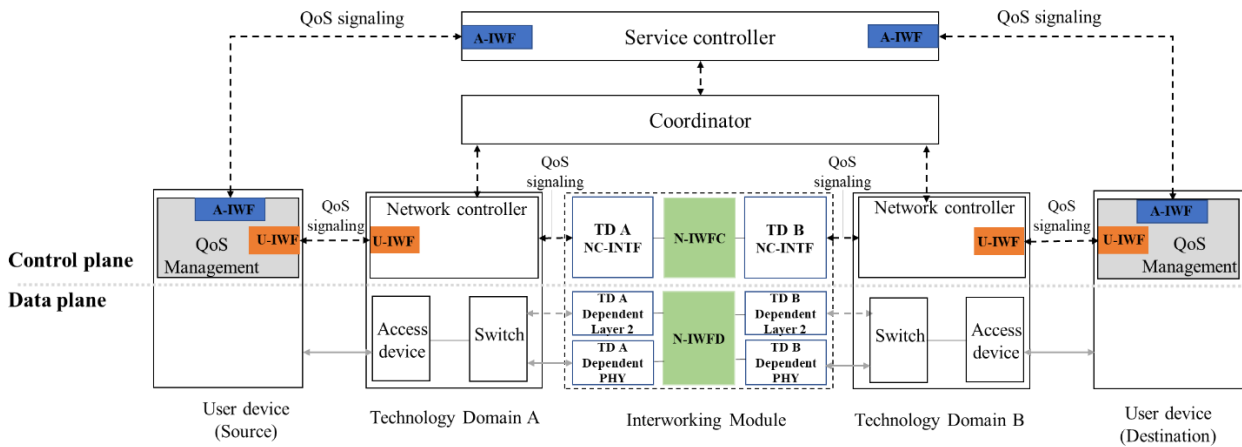

Figure 5 – Framework instance for centralized mode T2T interworking capability

NOTE – the general functions of access device and switch are defined in [ITU-T Y.3121].

As shown in Figure 5, TD A and TD B are connected through an independent Interworking Module (IM). In IM, two interworking functions are defined in control plane and data plane respectively.

In control plane, N-IWFC is a QoS interworking function between TDs. N-IWFC supports QoS signaling enabling exchange of QoS information through interworking TD's Network Controller-Interface (TD NC-INTF). N-IWFC supports functions such as horizontal QoS mapping and conversion between interworking TDs and QoS performance monitoring.

In data plane, N-IWFD is a data management and transmission protocol conversion function. N-IWFD supports flow identification, packet filtering, packet encapsulation and de-encapsulation, data buffering and forwarding. The packet receiving from previous TD (e.g., TD A) is buffered in N-IWFD, then is re-encapsulated within data format of the forwarding TD (e.g., TD B).

9.3.2 Distributed mode

Figure 6 shows the framework instance for distributed mode T2T interworking capability.

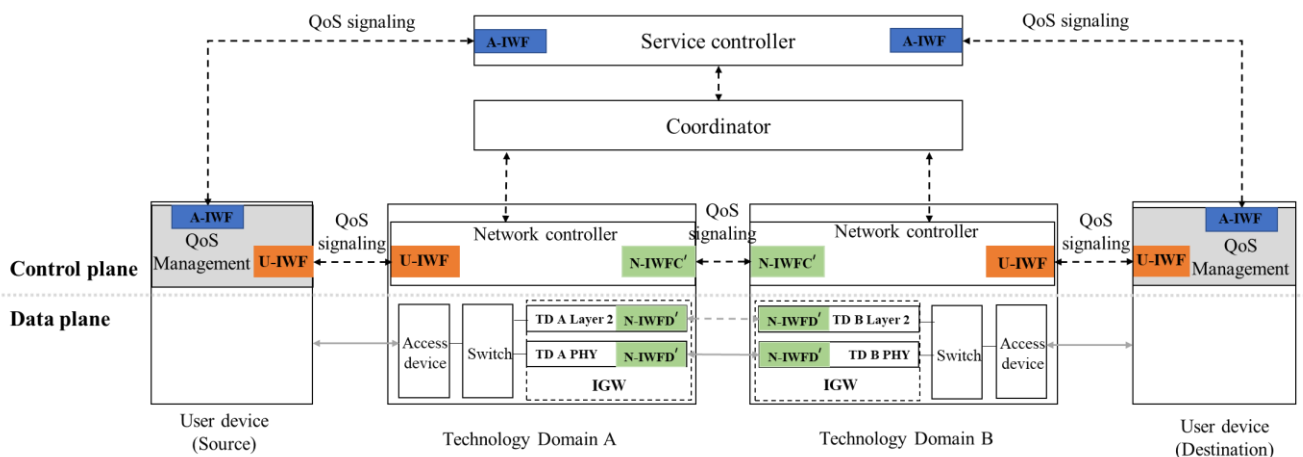

Figure 6 – Framework instance for distributed mode T2T interworking capability

As shown in Figure 6, TD A and TD B are connected directly through N-IWFC' in control plane and N-IWFD' in data plane, respectively. The interworking functions are distributed into two interworking TDs.

In control plane, N-IWFC' is a QoS interworking logical interface, which is separately distributed in network controllers of interworking TDs.

N-IWFC' supports control and management information exchange including information on QoS capabilities, control mechanisms and protocols, and QoS metrics. It also supports horizontal QoS mapping between interworking TDs.

In data plane, the Interworking Gateway function (IGW) is located at the border of each TD. IGW connects to the intra-TD devices (e.g., switch or access devices) with internal data transmission protocols of connected TD. It interacts with peer IGW of the interworking TD through N-IWFD'.

N-IWFD' is a data interworking interface defined in both data link layer and physical layer. N-IWFD' supports frame buffering, flow identification, frame filtering, frame encapsulation and de-encapsulation. Within N-IWFD', deterministic communication service can be transmitted across heterogeneous TDs.

10 Operational procedures of interworking capability

The three operational procedures of interworking capability are described in this clause: QoS negotiation, QoS decomposition and mapping, data processing and forwarding. QoS negotiation, QoS decomposition and mapping are procedures in the control plane, the data processing and forwarding is a procedure in the data plane.

10.1 QoS negotiation

QoS negotiation is a main procedure of A2A interworking capability, which determines the A2A QoS metrics. User devices, service controller and coordinator are involved in this procedure. Figure 7 describes the overall steps for QoS negotiation.

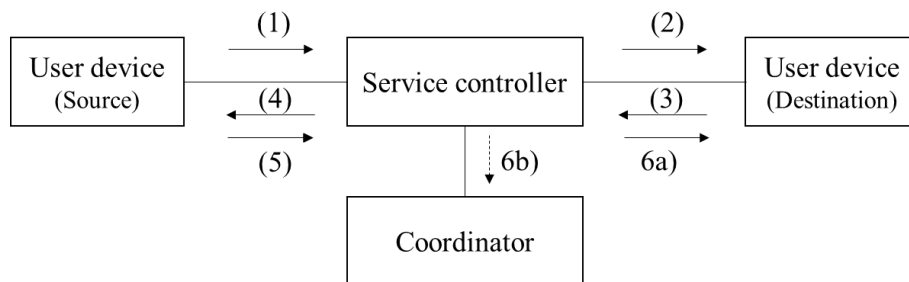

Figure 7. QoS negotiation procedure

- (1). The source user device sends a service request to the service controller with application-specific metrics, such as flow ID, flow direction, packet size, latency requirements, accepted packet loss rate and so on.
- (2). The service controller identifies a destination user device from the received service request, and forwards the service request to the corresponding destination user device.

- (3). The destination user device receives the service request, and then checks itself with available buffer space, computing resources, port status and so on. The destination user device decides if it can meet the requested QoS metrics. If no, it denies the service request and replies a Negative Acknowledgement (NACK) to the service controller. Otherwise, the destination user device specifies the QoS level metrics (e.g., latency upper bound, maximum burst size, minimal transmission rate, etc.) it can provide. Acknowledgement (ACK) response message to the service request, then sent to the service controller.
- (4). The service controller forwards the service request response to the corresponding source user device.
- (5). If the response is negative, the QoS negotiation procedure is finished. Otherwise, the source user device checks if the received QoS metrics can meet the service requirements. If yes, the source user device responses an ACK message with the negotiated QoS level parameters and then transmits it to the service controller. If no, the source user device responses a NACK message to the service controller.
- (6). The service controller receives the response message from the source user device and checks the content of the message. There are two cases:
 - 6a). This is a default step. Regardless of ACK or NACK in the response message to destination user device, the service controller should forward this message to the destination user device.
 - 6b). This is an optional step. If the response message is NACK, this step will not occur. If the response message is ACK, the service controller will forward ACK message with the negotiated QoS level parameters to the coordinator.

10.2 QoS decomposition and mapping

Within QoS level determined by QoS negotiation procedure, the QoS decomposition and mapping procedure aims to decompose the A2A QoS metrics and map to the TDs' QoS requirements. Service controller, coordinator and network controller in TDs are involved in this procedure. Figure 8 describes the overall steps for QoS decomposition and mapping.

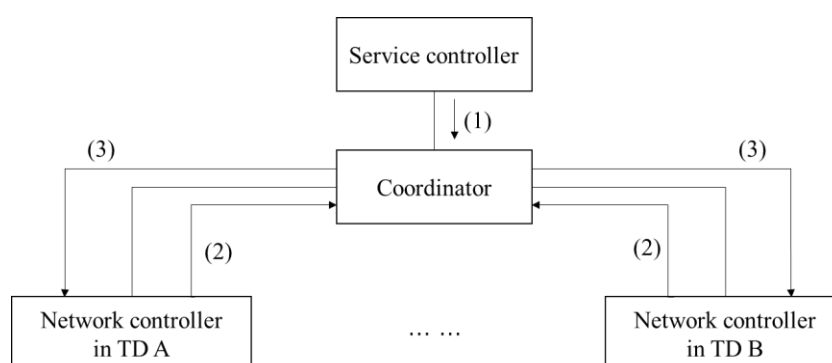

Figure 8. QoS decomposition and mapping procedure

- (1). The coordinator receives the negotiated QoS level parameters of all flows and collects the information of corresponding flows of the source and destination user devices.
- (2). Based on the information of successful negotiated flows, the coordinator collects network capability information of the corresponding TD such as available network resources, link and queuing status, the port and the load status of network devices, and so on.

The coordinator plans the transmission path for each flow. Furthermore, according to the negotiated A2A QoS level parameters and network capability information, the coordinator decides QoS requirements for each TD, and decomposes A2A QoS metrics into TD QoS metrics. Take end-to-end latency, for example, which is also explained in Appendix I. The negotiated end-to-end latency will be decomposed into several latency budget for each TD across the transmission path.

- (3). The coordinator distributes QoS metrics to the associated network controller in each TD.

10.3 Data processing and forwarding

After QoS decomposition and mapping, the network devices in TD will allocate resources for data transmission of the deterministic communication services to meet the QoS requirements. However, due to two T2T interworking mode, the different data processing and forwarding steps are described in sub-clause 10.3.1 and 10.3.2 respectively.

10.3.1 Procedure with distributed T2T interworking mode

Figure 9 describes the data processing and forwarding procedure with distributed T2T interworking mode and entities in data plane including source and destination user devices. Devices and gateway function in TD are involved in this procedure.

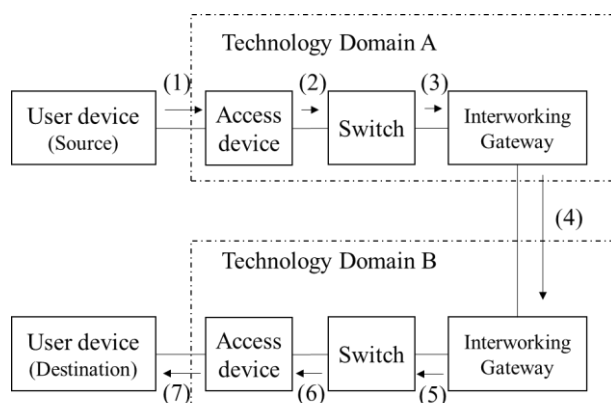

Figure 9. Data processing and forwarding procedure of distributed T2T interworking

- (1). The source user device sends the application data to access device in the interworking TD.
- (2). The access device receives the application data. Then the access device forward the application data to the switch over the transmission path provisioned by the coordinator.
- (3). The switch receives the application data and forwards it to the interworking gateway of TD A.

NOTE 1: in step (2), the access device can forward the application data to the interworking gateway directly, the switch is optional.

NOTE 2: in step (3), maybe there are many switches during the transmission path of the flow in TD A, the switch may deliver the application data to another switch.

- (4). The IGW in TD A may take several sub-steps as follows for protocol conversion and data forwarding.

- 4-1) It receives the application data encapsulated with the format of TD A from network devices in TD A, meanwhile it sets up the filtering and metering mechanism to check the application data .
 - 4-2) It de-encapsulates the received application data and re-encapsulates it with the new data format defined with peer entity in the interworking TD.
 - 4-3) It checks the port status, such as time synchronization, queuing state and so on. Once the port status meets the predefined rules, it will deliver the application data with new data format to the interworking gateway in interworking TD.
- (5). The IGW in TD B decapsulates the received application data from peer IGW in TD A, and encapsulates it with data format of TD B, then delivers application data to the switch in TD B.
 - (6). The switch receives the application data, and takes the filtering and metering mechanism, then forwards the application data to access device of TD B.
 - (7). The access device delivers the received application data to the destination user device.

NOTE 3: in step (5), the IGW in TD B may forward the data unit to the access device of TD B.

NOTE 4: in step (6), maybe there are many switches during the transmission path of the flow in TD B, the switch may deliver the data unit to another switch.

NOTE 5: the sum of latency in step (5) to (7) should not exceed the assigned latency budget in TD B defined in QoS decomposition and mapping procedure.

10.3.2 Procedure with centralized T2T interworking mode

Figure 10 describes the data processing and forwarding procedure with centralized T2T interworking mode. Entities in data plane including source and destination user devices, devices in each TD (access device and switches) and IM are involved in this procedure. In this scenario, the IM acts as an independent centralized entity to deal with protocol conversion across different TDs.

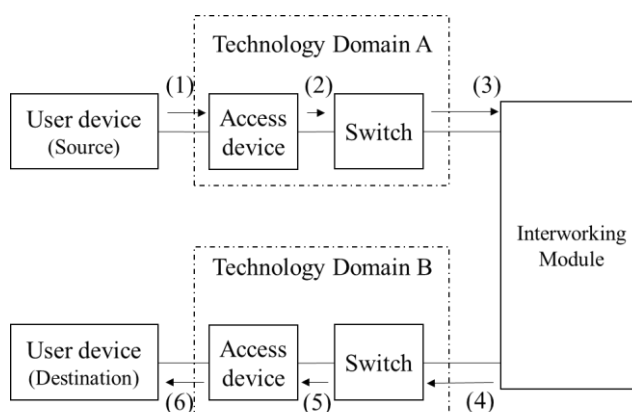

Figure 10. Data processing and forwarding procedure in centralized T2T interworking

- (1). This step is the same with step (1) in 10.3.1.
- (2). This step is the same with step (2) in 10.3.1.
- (3). The switch receives the application data, and then forwards it to the IM.
- (4). IM takes several following sub-steps to make communication across different TDs.

4-1) It receives the application data from the network devices in TD A, then sets up the filtering and metering mechanism to check the application data if it meets the maximum burst size, the minimal transmission rate and the latency requirement.

4-2) It performs the protocol conversion and the application data is encapsulated with format of TD B.

4-3) It transmits the new encapsulated application data to the network device in TD B.

(5). This step is the same with step (6) in 10.3.1.

(6). This step is the same with step (7) in 10.3.1.

NOTE 1: in step (2), the access device can forward the data unit to the interworking module directly, the switch is optional.

NOTE 2: in step (3) and (4), maybe there are many switches during the transmission path of the flow in TD A and TD B, the switch may deliver the data unit to another switch in the same TD.

NOTE 3: the sum of latency in step (1) to (3) should not exceed the assigned latency budget in TD A defined in QoS decomposition and mapping procedure. Meanwhile, the sum of latency in step (4) to (6) should not exceed the assigned latency budget in TD B defined in QoS mapping procedure.

Appendix I

An example of QoS assurance for data transmission across 5G and TSN

(This appendix does not form an integral part of this Recommendation.)

To describe the detailed QoS assurance scheme for data processing and forwarding procedure clearly, this part gives the data transmission across 5G and Time Sensitive Networking (TSN) as an example. Figure I.1 gives the overall system model for 5G and TSN technology domain, the Network-side TSN translator and Device-side TSN translator act as a centralized interworking module. It should be note that although this example is given as a centralized T2T interworking mode, the principle and QoS assurance scheme is also effective for the distributed T2T interworking mode.

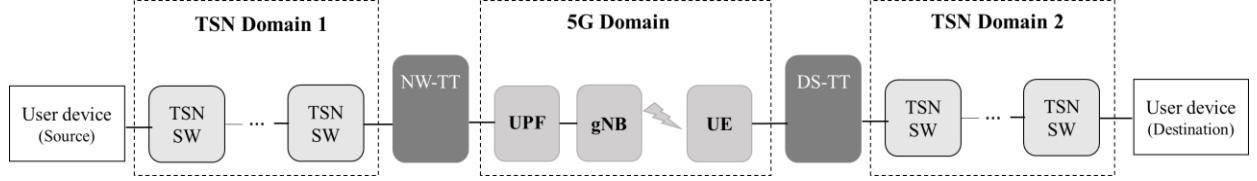

Figure I.1 – Overall system model for 5G and TSN technology domain

As for data transmission across 5G and TSN, it more cares about the end-to-end latency guarantee as QoS requirement. As shown in Figure I.2, the end-to-end latency of time-critical service is divided into several independent latency budgets in each technology domain and interworking modules, which aims to decrease signaling interaction as well as to provide solid guarantee for time critical service transmission across heterogeneous networks. In this example, the relationship between end-to-end latency requirement and latency budgets should follow the constraints described in formula (I-1).

$$D_{TSN1} + D_{TSN2} + D_{5Gs} + D_{IM1} + D_{IM2} \leq D_{e2e} \quad (I-1)$$

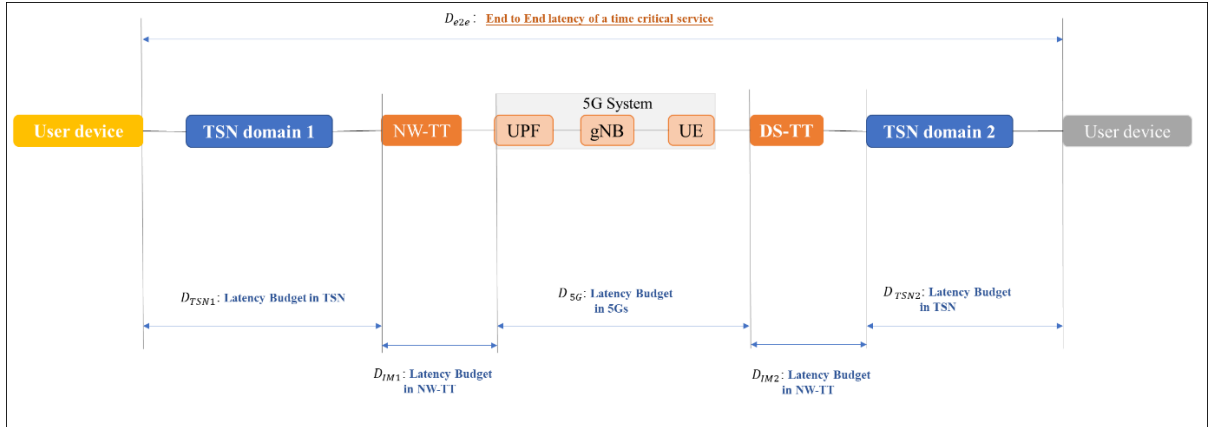

Figure I.2 – Illustration for independent latency budget for each TD and Interworking module

In TSN domain 1 and 2, it assumes that there are n and m TSN switches, respectively. The data transmission rate between each TSN switch are the same, but the queuing time in each switch is different, as a result, we can get the following formula.

$$D_{TSN1} - n \frac{L}{R} \geq \sum_{i=1}^n t_{TSN1}^{proc-i} \quad (I-2)$$

$$D_{TSN2} - m \frac{L}{R} \geq \sum_{i=1}^m t_{TSN2}^{proc-i} \quad (I-3)$$

where, L means the data unit size, and R is the data transmission rate between two adjacent TSN switch. Therefore, the GCL setting, which has an essential effect on queueing time, should be well optimized to satisfy this constraint.

For time budget of two centralized interworking module, it mainly includes the transmission delay and processing delay. As a result, the processing time should well design to satisfy the latency budget of interworking modules.

For the latency budget in 5G system, it can be further divided into two parts, the data transmission latency in core network and radio network. The data transmission latency in core network is stable, so the most uncertain part is the radio network. The 5G radio resource allocation and scheduling scheme should be optimized under the following constraints.

$$D_{5Gs} - D_{5Gs}^{core} \geq D_{5Gs}^{radio} \quad (\text{I-3})$$

According to the proposed method, if all the latency has been satisfied in each single part, the final QoS requirement can be guaranteed.

For the detailed QoS assurance schemes in TSN and 5Gs, see [b-Sun-2021].

Bibliography

- [b-ITU-T H.322] Recommendation ITU-T H.322 (1996), Visual telephone systems and terminal equipment for local area networks which provide a guaranteed quality of service.
- [b-ITU-T Y.1411] Recommendation ITU-T Y.1411 (2003), ATM-MPLS network interworking – Cell mode user plane interworking.
- [b-Sun-2021] Sun L., Wang J., Lin S., et al., *Research on 5G-TSN joint scheduling mechanism based on radio channel information*, Journal on Communications, 2021, 42(12).
-