



Question(s): 10/15

E-meeting, 7–18 September 2020

TD

Source: Editor G.8112/Y.1371

Title: Draft revised G.8112/Y.1371 (for consent)

Purpose: Discussion

Contact: Yuji Tochio
Fujitsu
JapanTel: +81-44-280-9936
E-mail: tochio@fujitsu.com

Keywords: G.8112/Y.1371

Abstract: This document is the latest draft of revised Recommendation ITU-T G.8112/Y.1371 “Interfaces for the MPLS transport profile layer network”.

Document history:

Version	Date	Description
3.1	08/2017	https://www.itu.int/rec/T-REC-G.8112-201708-I!Amd1/en (Base document for this draft)
3.2	TD513/3 (01/2020)	This version: <ul style="list-style-type: none"> • Updates the publication dates for the references in clause 2 • Applies the agreement reached on terminology per 3.1.4 of TD388/P and C.1296 (Jul 2019) with updates to clauses 2 and 3 • Applies the guidelines regarding “for further study” items in the Study Group 15 Guidelines for Recommendation Development Lifecycle document. Due to this update, some subclauses are renumbered.
3.3	TD592/P (08/2020)	This version: <ul style="list-style-type: none"> • Updates the publication dates for some references in clause 2 (G.8011 et al)
3.3	TD592r1/P (09/2020)	This version: <ul style="list-style-type: none"> • Updates the style of this Recommendation in align with revised G.8012. Based on this, clause 6.2 and 7 are updated. • Updates 6.2.4.3 and Figure 6-4 in align with G.709(2020)

International Telecommunication Union

ITU-T

TELECOMMUNICATION
STANDARDIZATION SECTOR
OF ITU

G.8112/Y.1371

Amendment 1
(xx08/202017)

SERIES G: TRANSMISSION SYSTEMS AND MEDIA,
DIGITAL SYSTEMS AND NETWORKS

Packet over Transport aspects – MPLS over Transport
aspects

SERIES Y: GLOBAL INFORMATION
INFRASTRUCTURE, INTERNET PROTOCOL ASPECTS,
NEXT-GENERATION NETWORKS, INTERNET OF
THINGS AND SMART CITIES

Internet protocol aspects – Transport

Interfaces for the MPLS transport profile layer
network

Amendment 1

Recommendation ITU-T G.8112/Y.1371 (202015) –
Amendment 1

ITU-T G-SERIES RECOMMENDATIONS
TRANSMISSION SYSTEMS AND MEDIA, DIGITAL SYSTEMS AND NETWORKS

INTERNATIONAL TELEPHONE CONNECTIONS AND CIRCUITS	G.100–G.199
GENERAL CHARACTERISTICS COMMON TO ALL ANALOGUE CARRIER-TRANSMISSION SYSTEMS	G.200–G.299
INDIVIDUAL CHARACTERISTICS OF INTERNATIONAL CARRIER TELEPHONE SYSTEMS ON METALLIC LINES	G.300–G.399
GENERAL CHARACTERISTICS OF INTERNATIONAL CARRIER TELEPHONE SYSTEMS ON RADIO-RELAY OR SATELLITE LINKS AND INTERCONNECTION WITH METALLIC LINES	G.400–G.449
COORDINATION OF RADIOTELEPHONY AND LINE TELEPHONY	G.450–G.499
TRANSMISSION MEDIA AND OPTICAL SYSTEMS CHARACTERISTICS	G.600–G.699
DIGITAL TERMINAL EQUIPMENTS	G.700–G.799
DIGITAL NETWORKS	G.800–G.899
DIGITAL SECTIONS AND DIGITAL LINE SYSTEM	G.900–G.999
MULTIMEDIA QUALITY OF SERVICE AND PERFORMANCE – GENERIC AND USER-RELATED ASPECTS	G.1000–G.1999
TRANSMISSION MEDIA CHARACTERISTICS	G.6000–G.6999
DATA OVER TRANSPORT – GENERIC ASPECTS	G.7000–G.7999
PACKET OVER TRANSPORT ASPECTS	G.8000–G.8999
Ethernet over Transport aspects	G.8000–G.8099
MPLS over Transport aspects	G.8100–G.8199
Synchronization, quality and availability targets	G.8200–G.8299
Service Management	G.8600–G.8699
ACCESS NETWORKS	G.9000–G.9999

For further details, please refer to the list of ITU-T Recommendations.

Recommendation ITU-T G.8112/Y.1371

Interfaces for the MPLS transport profile layer network

Amendment 1

Summary

Recommendation ITU-T G.8112/Y.1371 specifies the interfaces for the multi-protocol label switching transport profile (MPLS-TP) layer network. The interfaces for the MPLS-TP layer network use various server layer networks, like the plesiochronous digital hierarchy (PDH), synchronous digital hierarchy (SDH), optical transport hierarchy (OTH) and the Ethernet MAC layer network (ETH).

~~Amendment 1 avoids redefining terms already defined in Recommendations ITU-T G.8001/Y.1354 and ITU-T G.8101/Y.1355 by referencing these Recommendations.~~

History

Edition	Recommendation	Approval	Study Group	Unique ID*
1.0	ITU-T G.8112/Y.1371	2006-10-07	15	11.1002/1000/8783
1.1	ITU-T G.8112/Y.1371 (2006) Cor. 1	2007-01-09	15	11.1002/1000/9006
2.0	ITU-T G.8112/Y.1371	2012-10-29	15	11.1002/1000/11772
2.1	ITU-T G.8112/Y.1371 (2012) Amd. 1	2014-04-04	15	11.1002/1000/12187
2.2	ITU-T G.8112/Y.1371 (2012) Cor. 1	2015-01-13	15	11.1002/1000/12385
3.0	ITU-T G.8112/Y.1371	2015-08-13	15	11.1002/1000/12547
3.1	ITU-T G.8112/Y.1371 (2015) Amd. 1	2017-08-13	15	11.1002/1000/13315
<u>4.0</u>	<u>ITU-T G.8112/Y.1371</u>	<u>2020-xx-yy</u>	<u>15</u>	

* To access the Recommendation, type the URL <http://handle.itu.int/> in the address field of your web browser, followed by the Recommendation's unique ID. For example, <http://handle.itu.int/11.1002/1000/11830-en>.

FOREWORD

The International Telecommunication Union (ITU) is the United Nations specialized agency in the field of telecommunications, information and communication technologies (ICTs). The ITU Telecommunication Standardization Sector (ITU-T) is a permanent organ of ITU. ITU-T is responsible for studying technical, operating and tariff questions and issuing Recommendations on them with a view to standardizing telecommunications on a worldwide basis.

The World Telecommunication Standardization Assembly (WTSA), which meets every four years, establishes the topics for study by the ITU-T study groups which, in turn, produce Recommendations on these topics.

The approval of ITU-T Recommendations is covered by the procedure laid down in WTSA Resolution 1.

In some areas of information technology which fall within ITU-T's purview, the necessary standards are prepared on a collaborative basis with ISO and IEC.

NOTE

In this Recommendation, the expression "Administration" is used for conciseness to indicate both a telecommunication administration and a recognized operating agency.

Compliance with this Recommendation is voluntary. However, the Recommendation may contain certain mandatory provisions (to ensure, e.g., interoperability or applicability) and compliance with the Recommendation is achieved when all of these mandatory provisions are met. The words "shall" or some other obligatory language such as "must" and the negative equivalents are used to express requirements. The use of such words does not suggest that compliance with the Recommendation is required of any party.

INTELLECTUAL PROPERTY RIGHTS

ITU draws attention to the possibility that the practice or implementation of this Recommendation may involve the use of a claimed Intellectual Property Right. ITU takes no position concerning the evidence, validity or applicability of claimed Intellectual Property Rights, whether asserted by ITU members or others outside of the Recommendation development process.

As of the date of approval of this Recommendation, ITU had not received notice of intellectual property, protected by patents, which may be required to implement this Recommendation. However, implementers are cautioned that this may not represent the latest information and are therefore strongly urged to consult the TSB patent database at <http://www.itu.int/ITU-T/ipr/>.

© ITU 20172020

All rights reserved. No part of this publication may be reproduced, by any means whatsoever, without the prior written permission of ITU.

Table of Contents

	Page
1 Scope.....	1
2 References.....	1
3 Definitions	3
3.1 Terms defined elsewhere.....	3
3.2 Terms defined in this Recommendation.....	3
4 Abbreviations and acronyms	4
5 Conventions	6
6 MPLS transport profile layer network interface structure.....	6
6.1 NNI basic signal structure	7
6.2 Information structure for the MPLS-TP network node interfaces.....	10
6.3 MPLS-TP labels	17
6.4 MPLS-TP shim header	17
7 Multiplexing/mapping principles.....	18
7.1 Mapping.....	18
7.2 MPLS-TP multiplex	18
7.3 MPLS-TP tandem connection monitoring.....	18
8 Physical specification of the MPLS-TP interfaces	18
Appendix I – Example of layer networks in ETH UNI and MPLS-TP NNI.....	19
Appendix II – Bandwidth requirements for MPLS-TP transport	20

Recommendation ITU-T G.8112/Y.1371

Interfaces for the MPLS transport profile layer network

~~Amendment 1~~

1 Scope

This Recommendation specifies the interfaces for the multi-protocol label switching transport profile (MPLS-TP) layer network, in particular the:

- encapsulation of MPLS-TP client signals into the MPLS-TP characteristic information that will be present on MPLS-TP network-to-network interface (NNI) links in the transport network;
- encapsulation of MPLS-TP characteristic information into the MPLS-TP link frames that will be present on MPLS-TP NNI links in the transport network;
- MPLS-TP layer network within the transport network and associated MPLS-TP multiplexing;
- MPLS-TP nested connection monitoring per layer network level within the transport network;
- MPLS-TP operation, administration and maintenance (OAM) associated with nested connection monitoring in the transport network;
- encapsulation of MPLS-TP control plane information.

The MPLS-TP network uses various server layer networks like optical transport hierarchy (OTH), synchronous digital hierarchy (SDH), plesiochronous digital hierarchy (PDH) and Ethernet MAC layer network (ETH). The detailed requirements are specified in a number of ITU-T Recommendations, ANSI Standards, IEEE Standards and IETF RFCs, which are cited.

This Recommendation specifies point-to-point label-switched paths (LSPs); ~~point-to-multipoint LSPs are for further study.~~

This Recommendation does not cover inter-operator control plane aspects of the MPLS-TP NNI.

This Recommendation provides a representation of the MPLS-TP technology using the methodologies that have been used for other transport technologies [e.g., SDH, optical transport network (OTN) and Ethernet].¹

2 References

The following ITU-T Recommendations and other references contain provisions which, through reference in this text, constitute provisions of this Recommendation. At the time of publication, the editions indicated were valid. All Recommendations and other references are subject to revision; users of this Recommendation are therefore encouraged to investigate the possibility of applying the most recent edition of the Recommendations and other references listed below. A list of the currently valid ITU-T Recommendations is regularly published. The reference to a document within this Recommendation does not give it, as a stand-alone document, the status of a Recommendation.

¹ This Recommendation is intended to be aligned with the IETF MPLS RFCs normatively referenced by this Recommendation.

- [ITU-T G.704] Recommendation ITU-T G.704 (1998), *Synchronous frame structures used at 1544, 6312, 2048, 8448 and 44 736 kbit/s hierarchical levels.*
- [ITU-T G.705] Recommendation ITU-T G.705 (2000), *Characteristics of plesiochronous digital hierarchy (PDH) equipment functional blocks.*
- [ITU-T G.707] Recommendation ITU-T G.707/Y.1322 (2007), *Network node interface for the synchronous digital hierarchy (SDH).*
- [ITU-T G.709] Recommendation ITU-T G.709/Y.1331 (2020~~12~~), *Interfaces for the optical transport network.*
- [ITU-T G.832] Recommendation ITU-T G.832 (1998), *Transport of SDH elements on PDH networks – Frame and multiplexing structures.*
- [ITU-T G.951] Recommendation ITU-T G.951 (1988), *Digital line systems based on the 1544 kbit/s hierarchy on symmetric pair cables.*
- [ITU-T G.7041] Recommendation ITU-T G.7041/Y.1303 (2016~~11~~), *Generic framing procedure.*
- [ITU-T G.7043] Recommendation ITU-T G.7043/Y.1343 (2004), *Virtual concatenation of plesiochronous digital hierarchy (PDH) signals.*
- [ITU-T G.7712] Recommendation ITU-T G.7712/Y.1703 (~~2010~~2019), *Architecture and specification of data communication network.*
- ~~[ITU-T G.8001] Recommendation G.8001/Y.1354 (2016), Terms and definitions for Ethernet frames over transport.~~
- [ITU-T G.8011] Recommendation G.8011/Y.1307 (2020~~18~~), Ethernet service characteristics.
- [ITU-T G.8012] Recommendation G.8012/Y.1308 (2004), *Ethernet UNI and Ethernet NNI.*
- [ITU-T G.8040] Recommendation ITU-T G.8040/Y.1340 (2005), *GFP frame mapping into Plesiochronous Digital Hierarchy (PDH).*
- ~~[ITU-T G.8101] Recommendation G.8101/Y.1355 (2016), Terms and definitions for MPLS transport profile.~~
- [ITU-T G.8110.1] Recommendation ITU-T G.8110.1/Y.1370.1 (2011), *Architecture of the Multi-Protocol Label Switching transport profile layer network.*
- [ITU-T G.8151] Recommendation ITU-T G.8151/Y.1374 (~~2015~~2020~~18~~), *Management aspects of the MPLS-TP network element.*
- [ITU-T Y.1415] Recommendation ITU-T Y.1415 (2005), *Ethernet-MPLS network interworking – User plane interworking.*
- [ITU-Y Y.1711] Recommendation ITU-T Y.1711 (2004), *Operation & Maintenance mechanism for MPLS networks.*
- [ANSI T1.107] ANSI T1.107²-2002, *Digital hierarchy – Formats Specifications.*
- [IEEE 802.3] IEEE 802.3-2018~~12~~, *IEEE Standard for Information technology—Telecommunications and information exchange between systems—Local and metropolitan area networks—Specific requirements—Part 3: Carrier Sense Multiple Access with Collision Detection (CSMA/CD) Access Method and Physical Layer Specifications*Ethernet SECTION THREE.
- [IETF RFC 3031] IETF RFC 3031 (2001), *Multiprotocol Label Switching Architecture.*

² T1 standards are maintained since November 2003 by ATIS.

- [IETF RFC 3032] IETF RFC 3032 (2001), *MPLS Label Stack Encoding*.
- [IETF RFC 5586] IETF RFC 5586 (2009), *MPLS Generic Associated Channel*.
- [IETF RFC 5921] IETF RFC 5921 (2010), *A Framework for MPLS in Transport Networks*.
- [IETF RFC 5960] IETF RFC 5960 (2010), *MPLS Transport Profile Data Plane Architecture*.
- [IETF RFC 6215] IETF RFC 6215 (2011), *MPLS Transport Profile User-to-Network and Network-to-Network Interfaces*.
- [IETF RFC 7213] IETF RFC 7213 (2014), *MPLS Transport Profile (MPLS-TP) Next-Hop Ethernet Addressing*.

3 Definitions

3.1 Terms defined elsewhere

This Recommendation uses the following terms defined elsewhere:

3.1.1 customer edge: [IETF RFC 5921] ~~The client function that sources or sinks native service traffic to or from the MPLS-TP network. CEs on either side of the MPLS-TP network are peers and view the MPLS-TP network as a single link.~~

~~3.1.2 inter-domain interface:~~ [ITU-T G.8101]

~~3.1.3 intra-domain interface:~~ [ITU-T G.8101]

~~3.1.4 MPLS-TP characteristic information (MPLS-TP_CI) traffic unit:~~ [ITU-T G.8101]

3.1.25 MPLS-TP provider edge LSR (MPLS-TP PE): See clauses 1.3.5 and 1.3.5.2 of [IETF RFC 5921].

3.1.63 network-to-network interface (NNI): [ITU-T G.80018011]

3.1.74 user-to-network interface (UNI): [ITU-T G.80018011]

3.2 Terms defined in this Recommendation

3.2.1 inter-domain interface: A physical interface that represents the boundary between the administrative domains of different network operators.

3.2.2 intra-domain interface: A physical interface within the domain of a single network operator

3.2.3 MPLS-TP characteristic information (MPLS-TP_CI) traffic unit: An instance of characteristic information and a unit of usage, which consists of an MPLS-TP_AI traffic unit or of a MPLS-TP_OAM traffic unit, extended with an MPLS-TP_CI header containing the time-to-live (TTL) field of the MPLS shim header.

~~None.~~

4 Abbreviations and acronyms

This Recommendation uses the following abbreviations and acronyms:

- ACH Associated Channel Header
- AI Adapted Information
- CE Customer Edge
- cHEC core Header Error Check
- CI Characteristic Information

CII	Common Interworking Indicator
CLNS	Connectionless Network layer Service
CRC	Cyclic Redundancy Check
CW	Control Word
DA	Destination Address
DCN	Data Communication Network
ETH	Ethernet MAC layer network
EXI	Extension header Identifier
FCS	Frame Check Sequence
G-ACh	Generic Associated Channel
GAL	G-ACh Label
GFP	Generic Framing Procedure
GFP-F	Generic Framing Procedure – Frame Mapped
IaDI	Intra-Domain Interface
IP	Internet Protocol
IPG	Interpacket Gap
IrDI	Inter-Domain Interface
IS	Intermediate Service
LSP	Label-Switched Path
MAC	Media Access Control
MoE	MPLS-TP over ETH
MoO	MPLS-TP over OTH
MoP	MPLS-TP over PDH
MoS	MPLS-TP over SDH
MPLS	Multi-Protocol Label Switching
MT	MPLS Transport Profile
MPLS-TP	MPLS Transport Profile
MPLS-TPP	MPLS-TP Path
MPLS-TPT	MPLS-TP Tandem connection monitoring
MUG	MPLS-TP Unit Group
NNI	Network-to-Node Interface or Network-to-Network Interface
OAM	Operation, Administration and Maintenance
ODU	Optical channel Data Unit
ODUj	Optical channel Data Unit – order j
ODUj Xv	virtual concatenated Optical channel Data Unit – order j
ODUk	Optical channel Data Unit – order k
ODUk Xv	virtual concatenated Optical channel Data Unit – order k

OSI	Open Systems Interconnection
OSINL	Open Systems Interconnection Network Layer
OTH	Optical Transport Hierarchy
OTN	Optical Transport Network
P11s	1 544 kbit/s PDH path layer with synchronous 125 μ s frame structure according to [ITU-T G.704]
P12s	2 048 kbit/s PDH path layer with synchronous 125 μ s frame structure according to [ITU-T G.704]
P31e	34 368 kbit/s PDH path layer according to [ITU-T G.705]
P31s	34 368 kbit/s PDH path layer with synchronous 125 μ s frame structure according to [ITU-T G.832]
P32e	44 736 kbit/s PDH path layer according to [ITU-T G.705]
PDH	Plesiochronous Digital Hierarchy
PE	Provider Edge
PFI	Payload Frame check sequence Indicator
PLI	Payload Length Indicator
PTI	Payload Type Identifier
PW	Pseudowire
SA	Source Address
SCC	Signalling Communication Channel
SCN	Signalling Communication Network
SDH	Synchronous Digital Hierarchy
SFD	Start of Frame Delimiter
SPME	Sub-Path Maintenance Element
TC	Traffic Class
tHEC	type Header Error Check
TLV	Time, Length and Value
TTL	Time-To-Live
UNI	User-to-Network Interface
UNI-C	User-to-Network Interface, Client side
UNI-N	User-to-Network Interface, Network side
UPI	User Payload Identifier
VC	Virtual Container (SDH)
VC-m	Lower Order VC – order m
VC-n	Higher Order VC – order n
VC-n-Xc	contiguous concatenated VC – order n
VC-n-Xv	virtual concatenated VC – order n

VLAN Virtual Local Area Network

5 Conventions

None.

6 MPLS transport profile layer network interface structure

The MPLS-TP layer network as specified in [ITU-T G.8110.1] implies two interface classes:

- MPLS-TP layer network interface as specified in [IETF RFC 5921] and [IETF RFC 6215];
- client layer network interface as specified in [IETF RFC 5921] and [IETF RFC 6215].

The MPLS-TP layer interface can be deployed as a network-to-network interface (NNI) and within the transport network.

As described in [IETF RFC 5921], the MPLS-TP layer network consists of the Transport Service layer and the Transport Path layer.

The MPLS-TP NNI provides the interface between two MPLS-TP PEs and could be used for the support of client layer connection services, i.e., the Transport Service layer and the connection within transport, i.e., Transport Path layer.

The user-to-network interface (UNI) provides the interface for client services that are carried by MPLS-TP layers. UNIs are used for such a service. The location of the UNI and NNI is illustrated in Figure 6-1.

UNI functions are located at the customer edge (CE) and provider edge (PE). The UNI client side (UNI-C) is located and terminated at the CE and the UNI network side (UNI-N) is located and terminated at the PE. The functions for UNI-C and UNI-N are described in [IETF RFC 5921] and [IETF RFC 6215].

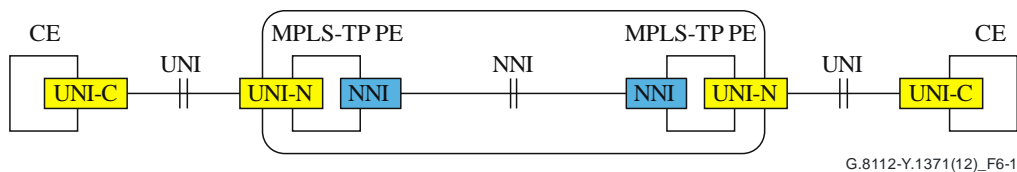

Figure 6-1 – Locations of UNI and MPLS-TP NNI

The MPLS-TP-NNI may be deployed as an intra-domain interface (IaDI) within a single administrative domain and as an inter-domain interface (IrDI) between two administrative domains as illustrated in Figure 6-2.

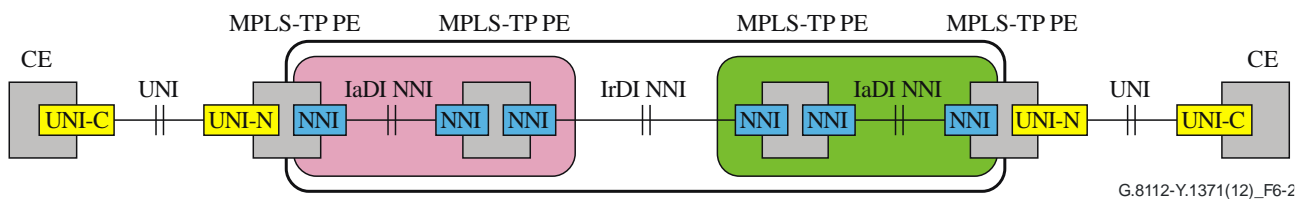
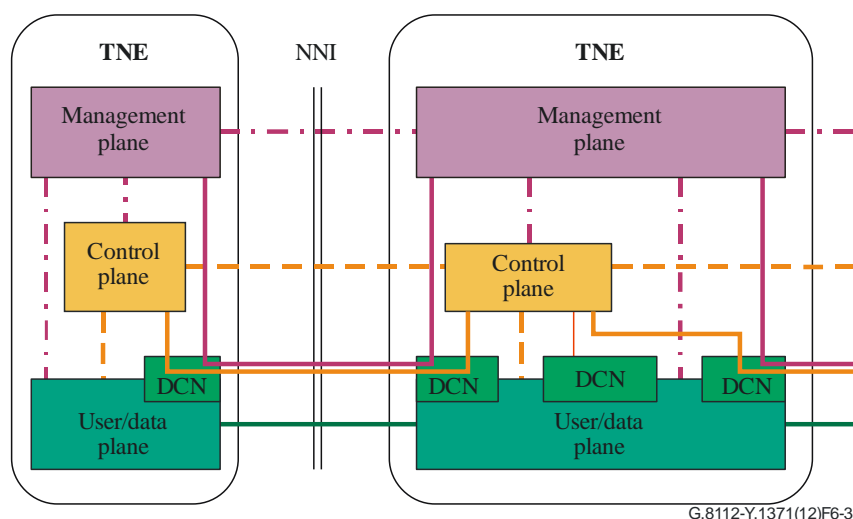

Figure 6-2 – Locations of client-UNI and MPLS-TP NNI

UNI and MPLS-TP NNI can encompass multiple layer networks. Appendix I describes an example of the Ethernet as the client service.

The MPLS-TP NNI can be used to carry informational elements of three planes (Figure 6-3):

- data (or user) plane, optionally including a data communication network (DCN) supporting management plane and control plane communications;
- control plane (e.g., signalling and routing);
- management plane.



G.8112-Y.1371(12)F6-3

Figure 6-3 – Three planes of MPLS-TP NNI

Each NNI is divided into three plane-specific NNIs:

- NNI_D for the data plane informational elements, including operation, administration and maintenance (OAM), which is terminated in the layer's termination, adaptation and connection/flow forwarding functions;
- NNI_C for the control plane informational elements;
- NNI_M for the management plane informational elements.

This Recommendation specifies NNI_D and NNI_C as defined in [IETF RFC 6215]. In [IETF RFC 6215], NNI_D and NNI_C are represented as NNI (network-to-network interface) function. An NNI function is defined at the interface of an MPLS-TE PE node as described in Figure 2 of [IETF RFC 6215].

NNI_C and NNI_M realized via the DCN interface are described in [ITU-T G.7712] and [ITU-T G.8151], respectively.

6.1 NNI basic signal structure

The basic structure is shown in Figure 6-4. The relationship between clients and MPLS-TP is described in [IETF RFC 5921] and the example of the clients for pseudowire (PW) is described in [IETF RFC 5960]. Note that this Recommendation only describes Ethernet as a client; ~~other clients for LSP or PW are for further study.~~

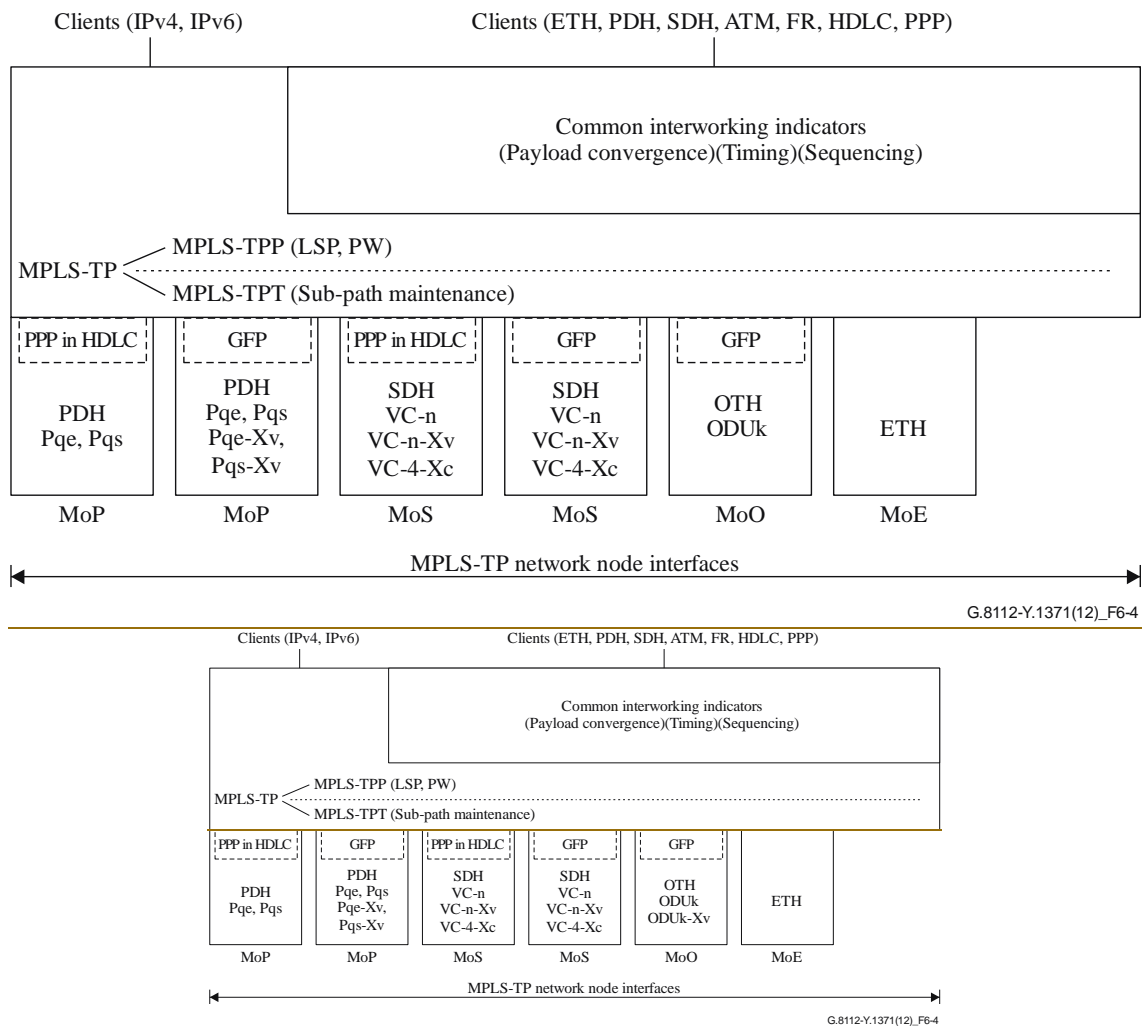

Figure 6-4 – Structure of the MPLS-TP network-to-node interfaces

6.1.1 MPLS-TP substructure

The MPLS-TP layer as defined in [ITU-T G.8110.1] is further structured in sublayers in order to support the tunnelling (aggregation of lower level MPLS_CI), network management and supervision functionalities defined in [ITU-T G.8110.1]:

- tunnelling;
- end-to-end MPLS-TP path supervision (MPLS-TPP);
- MPLS-TP tandem connection monitoring (MPLS-TPT);
- optional adaptation of client signals via control word (CW), also known as common interworking indicator (CII), headers.

As described in [ITU-T G.8110.1], a tunnel is associated with one or more LSPs. The tunnel is one of the primary constructs that is identified and it is used to identify the LSPs that are associated with it.

6.1.2 MPLS-TP transport network structure

As described in [IETF RFC 5960], the MPLS-TP network has no awareness of the internals of the server layer of which it is a client; it requires only that the server layer be capable of delivering the type of service required by the MPLS-TP transport entities that make use of it.

As described in [ITU-T G.8110.1], MPLS-TP may also be used to add a connection-oriented packet transport capability to an existing transport network, regardless of whether it is a circuit switched or packet switched transport network.

The MPLS-TP transport network interface consists of the multiple layers, of which only the first one is illustrated in Figure 6-4. The next layers are outside the scope of this Recommendation; the reader is referred to the appropriate technology Recommendations (e.g., [ITU-T G.707] for SDH).

There are a number of such MPLS-TP interfaces defined under this Recommendation as depicted in Figure 6-4:

- MPLS-TP-over-ETH (MoE);
- MPLS-TP-over-SDH (MoS);
- MPLS-TP-over-OTH (MoO);
- MPLS-TP-over-PDH (MoP).

In the case of circuit-switched transport, the payload bandwidths available are shown in Tables 6-1, 6-2 and 6-3, respectively, for PDH, in clauses 6 and 11 of [ITU-T G.707] for SDH and in clause 7 of [ITU-T G.709] for OTH.

Table 6-1 – Bandwidth of the payload of PDH path signals

PDH type	PDH payload (kbit/s)	In steps of (kbit/s)
P11s	1 536 – (64/24) ≈ 1 533	
P12s	1 980	
P31s	33 856	
P32e	(4 696/4 760) * 44 736 ≈ 44 134	
P11s-Xv, X = 1 to 16	≈ 1 533 to ≈ 24 528	≈ 1 533
P12s-Xv, X = 1 to 16	1 980 to 31 680	1 980
P31s-Xv, X = 1 to 8	33 856 to 270 848	33 856
P32e-Xv, X = 1 to 8	≈ 44 134 to ≈ 353 072	≈ 44 134

Table 6-2 – Bandwidth of the payload of SDH virtual containers (VCs)

VC type	VC payload (kbit/s)	In steps of (kbit/s)
VC-11	1 600	
VC-12	2 176	
VC-2	6 784	
VC-3	48 384	
VC-4	149 760	
VC-4-4e	599 040	
VC-4-16e	2 396 160	
VC-4-64e	9 584 640	
VC-4-256e	38 338 560	
VC-11-Xv, X = 1 to 64	1 600 to 102 400	1 600
VC-12-Xv, X = 1 to 64	2 176 to 139 264	2 176
VC-2-Xv, X = 1 to 64	6 784 to 434 176	6 784
VC-3-Xv, X = 1 to 256	48 384 to 12 386 304	48 384
VC-4-Xv, X = 1 to 256	149 760 to 38 338 560	149 760

Table 6-3—Bandwidth of the OTH ODUs

Optical channel data unit (ODU) type	OPU payload (kbit/s)	In steps of (kbit/s)
ODU flex	$(238/239) \times \text{ODU flex signal rate (for GFP-F mapped client signals)}$	
ODU0	1 238 954.310	
ODU1	2 488 320	
ODU2	$238/237 \times 9 953 280 \approx 9 995 277$	
ODU3	$238/236 \times 39 813 120 \approx 40 150 519$	
ODU4	104 355 975.330	
ODU1 Xv, X = 1 to 256	2 488 320 to 637 009 920	2 488 320
ODU2 Xv, X = 1 to 256	$\approx 9 995 277$ to $\approx 2 558 709 902$	$\approx 9 995 277$
ODU3 Xv, X = 1 to 256	$\approx 40 150 519$ to $\approx 10 278 532 946$	$\approx 40 150 519$

6.2 Information structure for the MPLS-TP network node interfaces

The information structure for the MPLS-TP network node interfaces is represented by information containment relationships and flows. The principal information containment relationships are described in Figure 6-5.

6.2.1 MPLS-TP principal information containment relationships

The MPLS-TP characteristic information (MPLS-TP_CI) consists of a stream of MPLS-TP_CI traffic units and OAM units. MPLS-TP_CI traffic units consist of a MPLS-TP adapted information (MPLS-TP_AI) traffic unit extended with an MPLS-TP_CI header containing the time-to-live (TTL) field of the MPLS-TP shim header (refer to clause 6.4). The MPLS-TP_AI traffic unit consists of a MPLS-TP_AI header containing the S field of the MPLS-TP shim header and a MPLS-TP payload field. The MPLS-TP payload field carries adapted client information or a label stack entry. A client signal of the MPLS-TP layer network is mapped into the MPLS-TP payload field via one of two different encapsulations (see Figure 6-5 and Table 6-24):

- direct encapsulation (IPv4, IPv6);
- control word based encapsulation (ETH).

MPLS-TP OAM signal and encapsulation is described in clause 6.2.1.1.

An example of an information flow relationship is shown in Figure 6-6.

Table 6-24 – Overview of encapsulated units

Encapsulation type	Reference
Internet protocol (IP) client encapsulation	(IPv4), clauses 2 and 3 of [IETF RFC 3032] (IPv6), clauses 2 and 3 of [IETF RFC 3032]
ETH client encapsulation	[ITU-T G.8110.1]
OAM encapsulation	[IETF RFC 5586] and [ITU-T G.8110.1]
Other	For further study

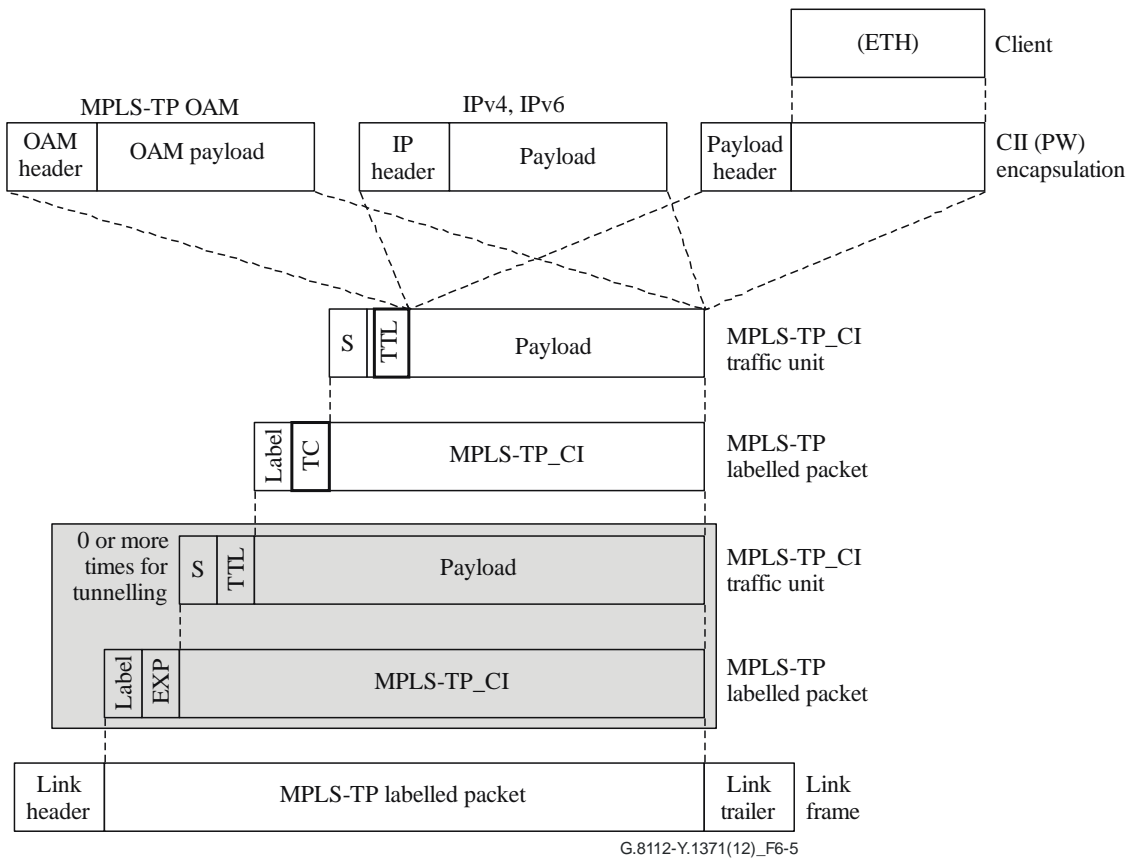

Figure 6-5 – MPLS-TP principal information containment relationships

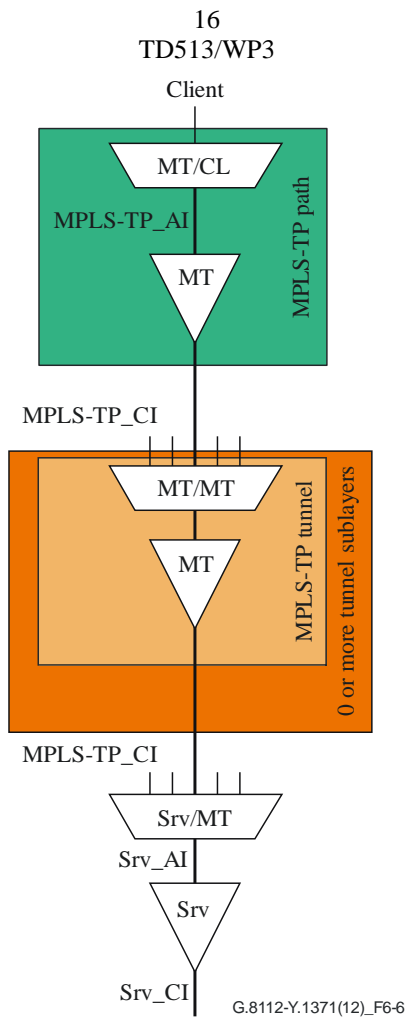

Figure 6-6 – Example of information flow relationship

6.2.1.1 MPLS-TP OAM

Figure 6-7 illustrates the generic format for MPLS-TP OAM.

The MPLS-TP OAM header consists of an MPLS-TP generic associated channel label (GAL) as defined in [IETF RFC 5586]. The MPLS-TP OAM payload consists of a generic associated channel (G-ACh) header, the associated channel header time, length and value (ACH TLV; optional), and G-ACh message. MPLS-TP OAM packets are distinguished from user data packets using the OAM header. Specific formats for MPLS-TP OAM are outside the scope of this Recommendation.

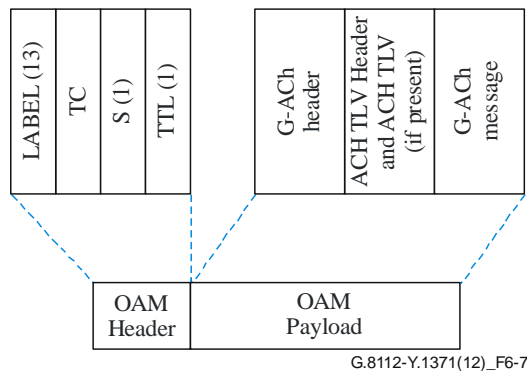

Figure 6-7 – Generic format for MPLS-TP OAM

6.2.1.2 Payload headers

6.2.1.2.1 ETH payload header

The mapping ETH payload header is described in clause 7.1 of [ITU-T G.8110.1].

6.2.2 MPLS-TP link frames

6.2.2.1 ETH link frame

The MPLS-TP_CI traffic unit (see [ITU-T G.8110.1]) is extended with a 3-bit traffic class (TC) field, a 20-bit label to complete the shim header. The resulting MPLS-TP labelled packet is then mapped as specified in [IETF RFC 3032], clauses 5 and 6.1 of [ITU-T G.8012] into the ETH payload information field using type encapsulation.

With the type encapsulation, the media access control destination address (MAC DA), MAC source address (MAC SA) and Type fields are prepended. The MAC DA can be the MAC address of the MPLS-TP next hop's interface or the broadcast MAC address (see [IETF RFC 7213]).

The MAC SA is the MAC address of the sending interface. The Type has value 0x8847. The [IEEE 802.3] frame check sequence (FCS) field with a 32-bit cyclic redundancy check (CRC) is appended. See Figure 6-8.

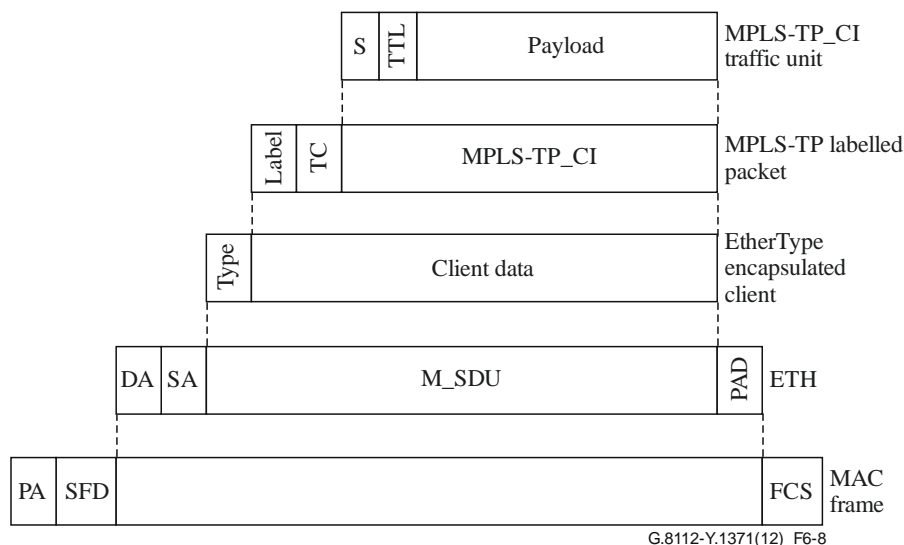

Figure 6-8 – Type encapsulation ETH link frame

6.2.2.2 GFP-F link frame

The MPLS-TP_CI traffic unit (see [ITU-T G.8110.1]) is extended with a 3-bit TC field, a 20-bit label to complete the shim header. The resulting MPLS-TP labelled packet is then mapped as specified in clause 7.6 of [ITU-T G.7041] in the generic framing procedure (GFP) payload information field. A core header with payload length indicator (PLI) and core header error check (cHEC) fields and a payload header field with payload type identifier (PTI), payload frame check sequence indicator (PFI), extension header identifier (EXI), user payload identifier (UPI) and type header error check (tHEC) subfields are prepended. The PTI subfield has value 000, the PFI subfield has value 1, the EXI subfield has value 0000 and the UPI subfield has value 0x0D. A payload FCS field with a 32-bit CRC is appended. See Figure 6-9. The maximum size of the GFP payload information field is specified in clause 6.1.2 of [ITU-T G.7041].

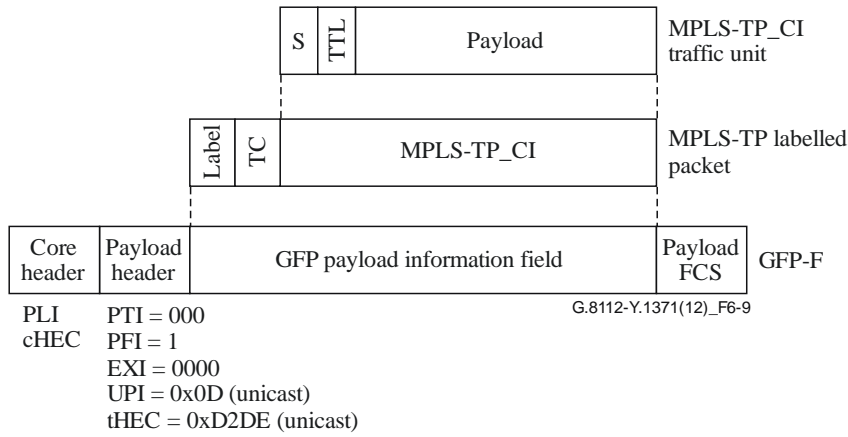

Figure 6-9 – GFP-F link frame

Figure 6-10 illustrates the mapping of the bits in the MPLS-TP labelled packet into the GFP payload information field within the generic framing procedure – frame mapped (GFP-F) frame.

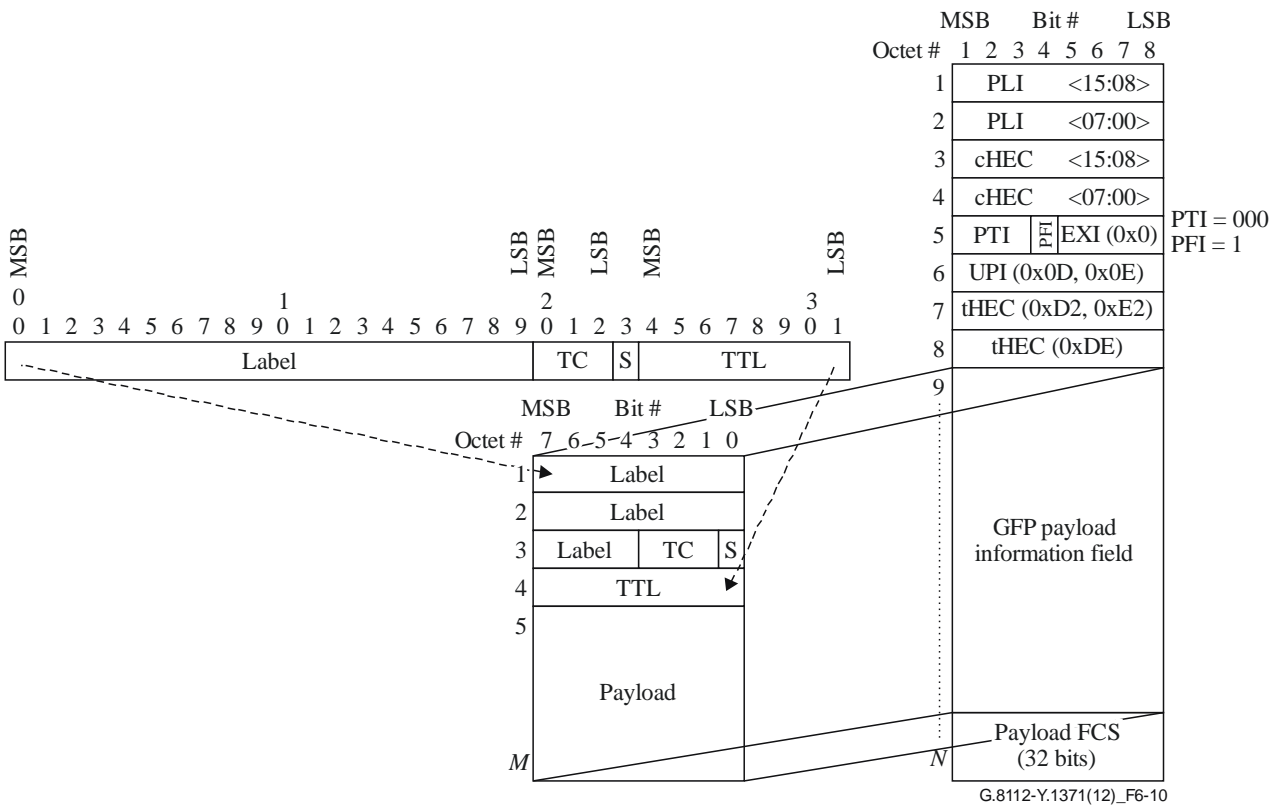

Figure 6-10 – Mapping MPLS-TP labelled packet into GFP-F link frame

6.2.3 MPLS-TP control frames

MPLS-TP control plane communication (NNI_C) for signalling and routing purposes is used for signalling communication network (SCN) links.

Four alternatives for SCN links are defined in [ITU-T G.7712].

- SCN link sharing a server layer trail with MPLS-TP user traffic.
- SCN link utilizing the MPLS-TP signalling communication channel (SCC).
- SCN link utilizing a dedicated MPLS-TP LSP.
- Separate and independent SCN link.

When an SCN link shares a server layer trail, MPLS-TP control frames are encapsulated either in IPv4 or in IPv6 or in open systems interconnection (OSI) network layer packets and sent natively on the MPLS-TP NNI. See Figure 6-11.

NOTE 1 – The encapsulation of the MPLS-TP control frames into IPv4, IPv6 or OSI network layer (OSINL) packets is outside the scope of this Recommendation.

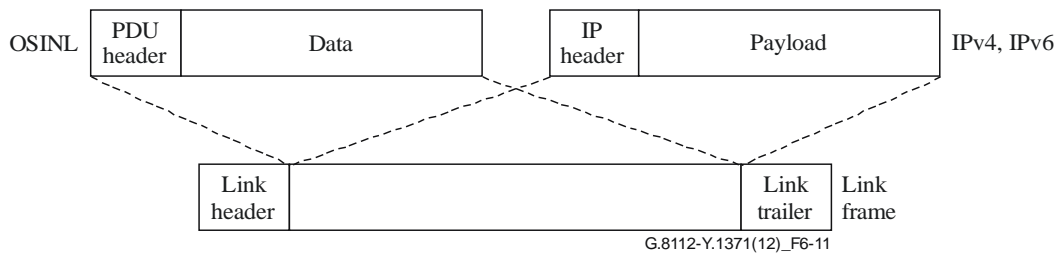

Figure 6-11 – MPLS-TP control frame over shared trail SCN links

Additional control frames can be required by the specific encapsulation method used for sending MPLS-TP link frames.

MPLS-TP control frames are distinguished from MPLS-TP data frames because they are not MPLS-TP link frames: the multiplexing of MPLS-TP and non-MPLS-TP link frames is required on all the MPLS-TP NNIs.

The encapsulation method used for MPLS-TP control frames is the same as the one used for the MPLS-TP link frames.

~~NOTE 2 – For cases other than SCN links sharing a server layer trail, the encapsulation of MPLS-TP control frames is for further study.~~

~~6.2.3.1 – ETH link frame~~

~~For further study.~~

6.2.3.21 – GFP-F link frame

The signalling and routing message is encapsulated into either IPv4 or IPv6 or OSI connectionless network layer service (CLNS) (intermediate service-intermediate service; IS-IS) packet as described in [ITU-T G.7712].

When the MPLS-TP NNI uses the GFP-F encapsulation, there are no other control protocols defined.

Control packets are encapsulated as specified in the standard references of Table 6-5 in the GFP payload information field. A core header with PLI and cHEC fields and a payload header field with PTI, PFI, EXI, UPI and tHEC subfields are prepended. The PTI subfield has value 000, the PFI subfield has value 1, the EXI subfield has value 0000 and the UPI subfield has the values defined in Table 6-35. A payload FCS field with a 32-bit CRC is appended.

Table 6-35 – Overview of GFP-F encapsulated control packets

Encapsulation type	Reference	UPI value
IP control packets	(IPv4) clause 7.7 of [ITU-T G.7041]	0x10
	(IPv6) clause 7.7 of [ITU-T G.7041]	0x11
OSI network layer control packets	(OSINL) clause 7.7 of [ITU-T G.7041]	0x0F

6.2.4 ~~MPLS-TP UNI~~

~~For further study.~~

6.2.54 MPLS-TP NNI

The MPLS-TP NNI is supported by the interfaces listed below.

6.2.45.1 MoE NNI

The MoE NNI deploys the Type encapsulation-based ETH link frame as specified in clause 6.2.2.1.

6.2.45.2 MoS NNI

The MoS NNI deploys the GFP-F link frame as specified in clause 6.2.2.2. The mapping of the GFP-F link frames into VC-11/VC-11-Xv, VC-12/VC-12-Xv, VC-3/VC-3-Xv, VC-4/VC-4-Xv and VC-4-Xc is specified in clause 10.6 of [ITU-T G.707].

Path overhead and virtual concatenation of the VCs is specified in [ITU-T G.707].

The components of the MPLS-TP over SDH NNI using the default encapsulation are illustrated in Figure 6-12.

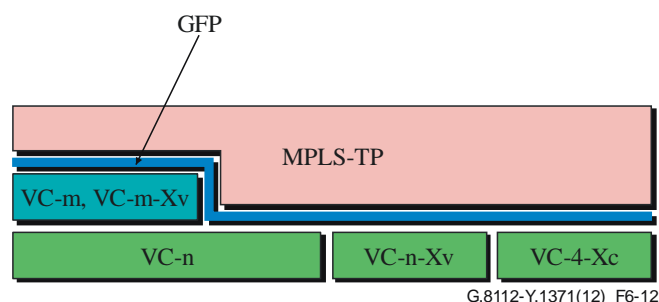

Figure 6-12 – Components of the MPLS-TP over SDH NNI using GFP-F encapsulation

6.2.45.3 MoO NNI

The MoO NNI deploys the GFP-F link frame as specified in clause 6.2.2.2 and its components are illustrated in Figure 6-13. The mapping of the GFP-F link frame into ODUj/ODUk ~~and ODUj-Xv~~ is specified in clauses 17.3 ~~and 18.2.4~~ respectively of [ITU-T G.709].

Path overhead ~~and virtual concatenation~~ of the ODUs is specified in [ITU-T G.709].

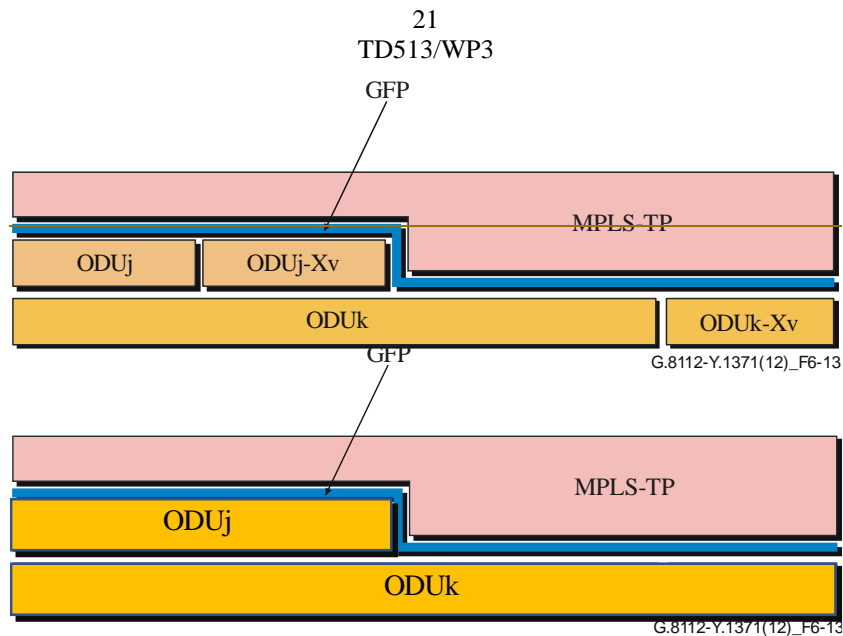

Figure 6-13 – Components of the MPLS-TP over OTH NNI

6.2.54.4 MoP NNI

The MoP NNI deploys the GFP-F link frame as specified in clause 6.2.2.2.

The mapping of the GFP-F link frames into P11s/P11s-Xv, P12s/P12s-Xv, P31s/P31s-Xv and P32e/P32e-Xv is specified in [ITU-T G.8040].

The frame structure of P11s, P12s and P32e is specified in [ITU-T G.704], the frame structure of P31e is specified in [ITU-T G.951] and the frame structure of P31s is specified in [ITU-T G.832]. Virtual concatenation of the P11s, P12s, P31s and P32e signals is specified in [ITU-T G.7043].

For the channelized P32e, the direct multiplexing of P11s into P32e is specified in clause 9.3 of [ANSI T1.107].

Figure 6-14 illustrates the relation of the components of MPLS-TP over PDH NNI using GFP-F.

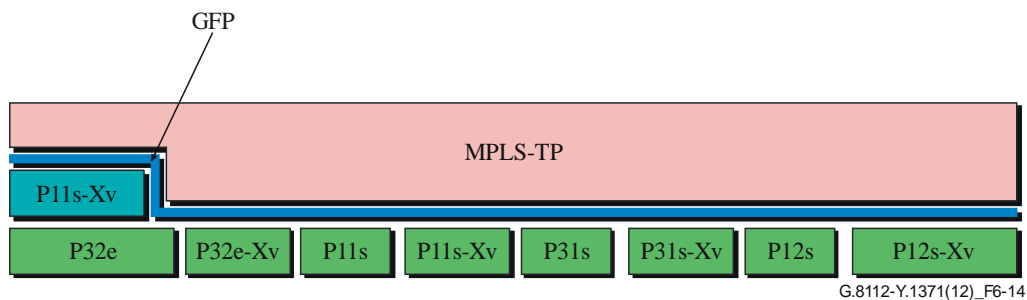

Figure 6-14 – Components of the MPLS-TP over PDH NNI using GFP-F

6.3 MPLS-TP labels

20 bits are available in the label field of the shim header for MPLS-TP connection identification. Some of these values are pre-assigned. The interpretation of these values is as described in Table 6-46.

Table 6-46 – MPLS-TP label value interpretation

MPLS-TP label value	Interpretation
0-3	Defined in [IETF RFC 3032]; not used in MPLS-TP
4-12	Reserved for future standardization (Note)
13	Defined in [IETF RFC 5586]
14	Defined in [ITU-T Y.1711]; not used in MPLS-TP
15	Reserved for future standardization (Note)
16-1 048 575	MPLS-TP connection identifier range (values assigned as per [IETF RFC 3031])
NOTE – The Internet Assigned Numbers Authority (IANA) allocates these values through the Internet Engineering Task Force (IETF) consensus action process.	

6.4 MPLS-TP shim header

The MPLS-TP traffic unit includes one or more MPLS shim headers as defined in [IETF RFC 3031] and specified as label stack entry in section 2 of [IETF RFC 3032].

7 Multiplexing/mapping principles

Figure 7-1 shows the relationship between various information structure elements and illustrates the multiplexing structure and mappings for the MPLS-TP from client signal to link frames. It illustrates an n-level multiplexing of MPLS-TP signals into MPLS-TP LSP. The MPLS transport profile characteristic information (MT_CI) traffic is multiplexed into an MPLS-TP unit group level 1 (MUG1). The MUG1 is extended with a second level MPLS shim header and then multiplexed into a higher MUG level.

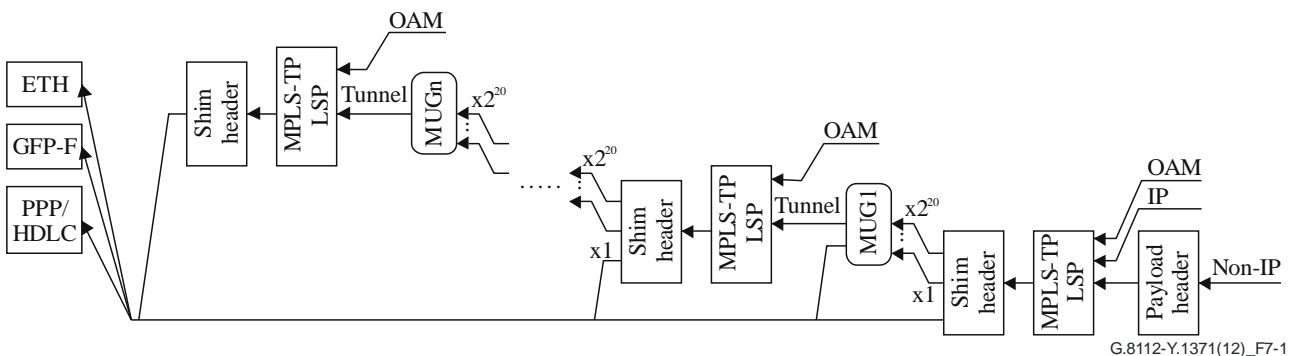

Figure 7-1 – MPLS-TP mapping, multiplexing and segment monitoring

7.1 Mapping

The client signal is mapped into the MPLS-TP LSP directly (like IP clients). For non-IP clients like Ethernet, a CW is optionally used as referred to [ITU-T G.8110.1]. The CW is also known as the CII in [ITU-T Y.1415].

MPLS-TP OAM (refer to clause 6.2.1.1) may be added and both data and OAM packets are extended with a shim header (refer to clause 6.4).

The MPLS-TP packets are then mapped into the applicable link frames as specified in clauses 6.2.2 and those link frames are transported over a MPLS-TP topological link.

7.2 MPLS-TP multiplex

The label-stacking mechanism in MPLS-TP provides an n-level MPLS-TP LSP multiplexing capability. The 20-bit label in the shim header identifies the individual MPLS-TP tributaries within the aggregate (MPLS-TP tunnel) signal. Up to 2^{20} MPLS-TP tributaries can be supported in the aggregate signal.

7.3 MPLS-TP tandem connection monitoring

Multiplexing may not be performed in all stacking steps to support one or more levels of MPLS-TP tandem connection monitoring [sub-path maintenance element (SPME)] as described in [ITU-T G.8110.1]. ~~The mechanism is for further study.~~

8 Physical specification of the MPLS-TP interfaces

There are no dedicated MPLS-TP physical interfaces. MPLS-TP interfaces are supported by physical interfaces specified in the following transport technologies: PDH, SDH, OTH and Ethernet.

Appendix I

Example of layer networks in ETH UNI and MPLS-TP NNI

(This appendix does not form an integral part of this Recommendation.)

[ITU-T G.8110.1] defines Ethernet as the client of MPLS-TP. Ethernet UNI and NNI are defined in [ITU-T G.8012]. The ETH UNI, ETH NNI and MPLS-TP NNI encompass multiple layer networks, each with its dedicated UNI and NNI (Figure I.1). ETY UNI is defined in [ITU-T G.8012].

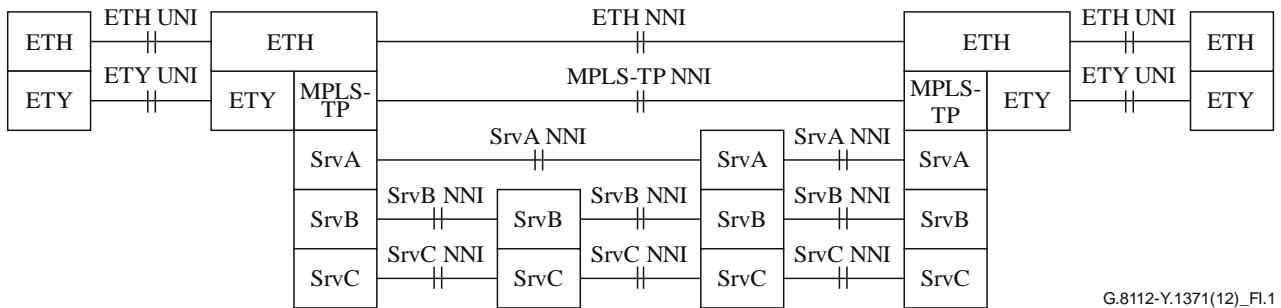

Figure I.1 – Example of layer networks in ETH UNI and MPLS-TP NNI

Appendix II

Bandwidth requirements for MPLS-TP transport

(This appendix does not form an integral part of this Recommendation.)

This appendix shows the transport bandwidth requirements for ETH client encapsulation over MPLS-TP over ETH link as a function of the Ethernet MAC rate, the client payload field length, whether or not the network has inserted a virtual local area network (VLAN) tag. This is shown in Tables II.1 and II.2.

NOTE – The MAC bit rate in Table II.1 is the actual bit rate of the Ethernet MAC frames after the removal of the 12-byte inter-packet gap plus 7-byte preamble + 1-byte start of frame delimiter. In other words, MAC bit rate = (Ethernet interface rate) (number of bits in the MAC frame)/(number of bits in the MAC frame + 12-byte inter-packet gap + 7-byte preamble + 1-byte start of frame delimiter). The calculations in Table II.2 are the same except that 10 gigabit Ethernet uses a 5-byte minimum inter-packet gap instead of 12 bytes.

Table II.1 – Maximum (un)tagged MAC bit rate per "1 Gbit/s" MAC server signal

		Payload bit rate (bit/s, nominal bit rate for Ethernet)					
		1 000 000 000		1 000 000 000		1 000 000 000	
		MAC bit rate (kbit/s), throughput (%) relative to maximum MAC bit rate			Packets per second (pps), throughput (%) relative to maximum packet per second		
VLAN tag	MAC-size (Bytes)	1000Base-X	MPLS-TP over 1000Base-X	Through-put	1000Base-X	MPLS-TP over 1000Base-X	Through-put
0	64	761.905	581.818	76.36%	1.488.095	1.136.364	76.36%
0	128	864.865	735.632	85.06%	844.595	718.391	85.06%
0	256	927.536	847.682	91.39%	452.899	413.907	91.39%
0	512	962.406	917.563	95.34%	234.962	224.014	95.34%
0	1 024	980.843	957.009	97.57%	119.732	116.822	97.57%
0	1 518	986.996	970.588	98.34%	81.274	79.923	98.34%
0	9 618	997.925	995.240	99.73%	12.969	12.935	99.73%
1	64	772.727	596.491	77.19%	1.420.455	1.096491	77.19%
1	128	868.421	741.573	85.39%	822.368	702.247	85.39%
1	256	928.571	849.673	91.50%	446.429	408.497	91.50%
1	512	962.687	918.149	95.37%	233.209	222.420	95.37%
1	1 024	980.916	957.169	97.58%	119.275	116.387	97.58%
1	1 518	987.030	970.663	98.34%	81.064	79.719	98.34%
1	9 618	997.926	995.242	99.73%	12.964	12.929	99.73%

NOTE 1 – VLAN tag; value gives the number of VLAN tags (no VLAN tag = 0).
NOTE 2 – Encapsulation overhead; 20 bytes for physical Ethernet interface [7-byte preamble, 1-byte start of frame delimiter (SFD) and 12-byte minimum interpacket gap (IPG)]. 26-byte Encapsulation overhead for ETH client over MPLS-TP with CW.

Table II.2 – Maximum (un)tagged MAC bit rate per "10 Gbit/s" MAC server signal

		Payload bit rate (nominal bit rate for Ethernet)					
		10 000 000 000		10 000 000 000		1 000 000 000	
		MAC bit rate (kbit/s), throughput (%) relative to maximum MAC bit rate			Packets per second (pps), throughput (%) relative to maximum packet per second		
VLAN tag	MAC-size (Bytes)	10GBase-R	MPLS-TP over 10GBase-R	Throughput	10GBase-R	MPLS-TP over 10GBase-R	Throughput
0	64	7.619.048	5.818.182	76.36%	14.880.952	11.363.636	76.36%
0	128	8.648.649	7.356.322	85.06%	8.445.946	7.183.908	85.06%
0	256	9.275.362	8.476.821	91.39%	4.528.986	4.139.073	91.39%
0	512	9.624.060	9.175.627	95.34%	2.349.624	2.240.143	95.34%
0	1 024	9.808.429	9.570.093	97.57%	1.197.318	1.168.224	97.57%
0	1 518	9.869.961	9.705.882	98.34%	812.744	799.233	98.34%
0	9 618	9.979.249	9.952.401	99.73%	129.695	129.346	99.73%
1	64	7.727.273	5.964.912	77.19%	14.204.545	10.964.912	77.19%
1	128	8.684.211	7.415.730	85.39%	8.223.684	7.022.472	85.39%
1	256	9.285.714	8.496.732	91.50%	4.464.286	4.084.967	91.50%
1	512	9.626.866	9.181.495	95.37%	2.332.090	2.224.199	95.37%
1	1 024	9.809.160	9.571.695	97.58%	1.192.748	1.163.873	97.58%
1	1 518	9.870.298	9.706.633	98.34%	810.636	797.194	98.34%
1	9 618	9.979.257	9.952.420	99.73%	129.641	129.293	99.73%

NOTE 1 – VLAN tag; value gives the number of VLAN tags (no VLAN tag = 0).
NOTE 2 – Encapsulation overhead; 20 bytes for physical Ethernet interface (7-byte preamble, 1-byte SFD and 12-byte minimum IPG). 26-byte Encapsulation overhead for ETH client over MPLS-TP with CW.

ITU-T Y-SERIES RECOMMENDATIONS

GLOBAL INFORMATION INFRASTRUCTURE, INTERNET PROTOCOL ASPECTS, NEXT-GENERATION NETWORKS, INTERNET OF THINGS AND SMART CITIES

GLOBAL INFORMATION INFRASTRUCTURE	
General	Y.100–Y.199
Services, applications and middleware	Y.200–Y.299
Network aspects	Y.300–Y.399
Interfaces and protocols	Y.400–Y.499
Numbering, addressing and naming	Y.500–Y.599
Operation, administration and maintenance	Y.600–Y.699
Security	Y.700–Y.799
Performances	Y.800–Y.899
INTERNET PROTOCOL ASPECTS	
General	Y.1000–Y.1099
Services and applications	Y.1100–Y.1199
Architecture, access, network capabilities and resource management	Y.1200–Y.1299
Transport	Y.1300–Y.1399
Interworking	Y.1400–Y.1499
Quality of service and network performance	Y.1500–Y.1599
Signalling	Y.1600–Y.1699
Operation, administration and maintenance	Y.1700–Y.1799
Charging	Y.1800–Y.1899
IPTV over NGN	Y.1900–Y.1999
NEXT GENERATION NETWORKS	
Frameworks and functional architecture models	Y.2000–Y.2099
Quality of Service and performance	Y.2100–Y.2199
Service aspects: Service capabilities and service architecture	Y.2200–Y.2249
Service aspects: Interoperability of services and networks in NGN	Y.2250–Y.2299
Enhancements to NGN	Y.2300–Y.2399
Network management	Y.2400–Y.2499
Network control architectures and protocols	Y.2500–Y.2599
Packet-based Networks	Y.2600–Y.2699
Security	Y.2700–Y.2799
Generalized mobility	Y.2800–Y.2899
Carrier grade open environment	Y.2900–Y.2999
FUTURE NETWORKS	Y.3000–Y.3499
CLOUD COMPUTING	Y.3500–Y.3999
INTERNET OF THINGS AND SMART CITIES AND COMMUNITIES	
General	Y.4000–Y.4049
Definitions and terminologies	Y.4050–Y.4099
Requirements and use cases	Y.4100–Y.4249
Infrastructure, connectivity and networks	Y.4250–Y.4399
Frameworks, architectures and protocols	Y.4400–Y.4549
Services, applications, computation and data processing	Y.4550–Y.4699
Management, control and performance	Y.4700–Y.4799
Identification and security	Y.4800–Y.4899
Evaluation and assessment	Y.4900–Y.4999

For further details, please refer to the list of ITU-T Recommendations.

SERIES OF ITU-T RECOMMENDATIONS

Series A	Organization of the work of ITU-T
Series D	Tariff and accounting principles and international telecommunication/ICT economic and policy issues
Series E	Overall network operation, telephone service, service operation and human factors
Series F	Non-telephone telecommunication services
Series G	Transmission systems and media, digital systems and networks
Series H	Audiovisual and multimedia systems
Series I	Integrated services digital network
Series J	Cable networks and transmission of television, sound programme and other multimedia signals
Series K	Protection against interference
Series L	Environment and ICTs, climate change, e-waste, energy efficiency; construction, installation and protection of cables and other elements of outside plant
Series M	Telecommunication management, including telecommunication network management and network maintenance
Series N	Maintenance: international sound programme and television transmission circuits
Series O	Specifications of measuring equipment
Series P	Telephone transmission quality, telephone installations, local line networks
Series Q	Switching and signalling, and associated measurements and tests
Series R	Telegraph transmission
Series S	Telegraph services terminal equipment
Series T	Terminals for telematic services
Series U	Telegraph switching
Series V	Data communication over the telephone network
Series X	Data networks, open system communications and security
Series Y	Global information infrastructure, Internet protocol aspects, next-generation networks, Internet of Things and smart cities
Series Z	Languages and general software aspects for telecommunication systems
