Question(s): 10, 14/15

15-26 February 2016

TD

Source: Editor G.8121.1/Y.1381.1

Title: Draft revised Recommendation ITU-T G.8121.1/Y.1381.1 (for Consent, 26 February 2016)

Abstract

This document provides the draft revised G.8121.1/Y.1381.1 (for consent, 26 February 2016).

Summary of major updates from version 1 (G.8121.1 (2013))

- To support proactive LM and DM in align with draft G.8113.1 ([wd20](#), Ottawa), clause 9.2.1 defines MIs for proactive LM and DM. Also the placeholders of 8.8.4 and 8.8.6 are provided.
- Added intermediate request to on-demand loss/delay measurement in clause 8.8.5/7 and clause 9.4.1.1 (MTDe_TT)
- Fixed some behaviors in OAM related processes in clause 8.8.
- Fixed LStack behaviour in some atomic functions in clause 9
- Fixed some incorrect titles of references.
- Fixed some incorrect diagrams (including SDL diagrams)

Contact: Yuji Tochio
Fujitsu
Japan

Tel: +81-44-754-8829
Email: tochio@jp.fujitsu.com

Attention: This is not a publication made available to the public, but **an internal ITU-T Document** intended only for use by the Member States of ITU, by ITU-T Sector Members and Associates, and their respective staff and collaborators in their ITU related work. It shall not be made available to, and used by, any other persons or entities without the prior written consent of ITU-T.

Draft revised Recommendation ITU-T G.8121.1/Y.1381.1

Characteristics of MPLS-TP equipment functional blocks supporting ITU-T G.8113.1/Y.~~1373~~1372.1 OAM mechanisms

Summary

Recommendation ITU-T G.8121.1/Y.1381.1 specifies both the functional components and the methodology that should be used in order to specify MPLS-TP layer network functionality of network elements based on the protocol neutral constructs defined in ITU-T G.8121 and on the tools defined in- ITU-T G.8113.1/Y.~~1373~~1372.1.

Keywords

Atomic functions, equipment functional blocks, MPLS-TP layer network, MPLS-TP.

Draft revised Recommendation ITU-T G.8121.1/Y.1381.1

Characteristics of MPLS-TP equipment functional blocks supporting ITU-T G.8113.1/Y.~~1373~~1372.1 OAM mechanisms

1 Scope

This Recommendation describes both the functional components and the methodology that should be used in order to describe MPLS-TP layer network functionality of network elements; it does not describe individual MPLS-TP network equipment as such.

This recommendation provides protocol-specific extensions of the protocol-neutral constructs defined in [ITU-T G.8121] to support the OAM tools defined in [ITU-T G.8113.1]

This Recommendation provides a description of the MPLS-TP functional technology using the same methodologies that have been used for other transport technologies (e.g. SDH, OTN and Ethernet).

This Recommendation forms part of a suite of Recommendations covering the full functionality of network equipment. These Recommendations are [ITU-T G.806], [ITU-T G.8121], [ITU-T G.798], [ITU-T G.783], [ITU-T G.705] and [ITU-T G.8021]. This Recommendation also follows the principles defined in [ITU-T G.805].

These Recommendations specify a library of basic building blocks and a set of rules by which they may be combined in order to describe digital transmission equipment. The library comprises the functional building blocks needed to specify completely the generic functional structure of the MPLS-TP layer network. In order to be compliant with this Recommendation, equipment needs to be describable as an interconnection of a subset of these functional blocks contained within this Recommendation. The interconnections of these blocks should obey the combination rules given.

Not every atomic function defined in this Recommendation is required for every application. Different subsets of atomic functions may be assembled in different ways according to the combination rules given in this Recommendation to provide a variety of different capabilities. Network operators and equipment suppliers may choose which functions must be implemented for each application.

2 References

The following ITU-T Recommendations and other references contain provisions, which, through reference in this text, constitute provisions of this Recommendation. At the time of publication, the editions indicated were valid. All Recommendations and other references are subject to revision; users of this Recommendation are therefore encouraged to investigate the possibility of applying the most recent edition of the Recommendations and other references listed below. A list of the currently valid ITU-T Recommendations is regularly published.

The reference to a document within this Recommendation does not give it, as a stand-alone document, the status of a Recommendation.

[ITU-T G.705] Recommendation ITU-T G.705 (2000), *Characteristics of plesiochronous digital hierarchy (PDH) equipment functional blocks*.

[ITU-T G.783] Recommendation ITU-T G.783 (2006), *Characteristics of synchronous digital hierarchy (SDH) equipment functional blocks*.

- [ITU-T G.798] Recommendation ITU-T G.798 (2010), Characteristics of optical transport network hierarchy equipment functional blocks
- [ITU-T G.805] Recommendation ITU-T G.805 (2000), *Generic functional architecture of transport networks*.
- [ITU-T G.806] Recommendation ITU-T G.806 (2012), *Characteristics of transport equipment – Description methodology and generic functionality*.
- [ITU-T G.8021] Recommendation ITU-T G.8021/Y.1341 (2015), *Characteristics of Ethernet transport network equipment functional blocks*.
- [ITU-T G.8101] Recommendation ITU-T G.8101/Y.1355 (2015), *Terms and definitions for MPLS transport profile*.
- [ITU-T G.8113.1] Recommendation ITU-T G.8113.1/Y.1372.1 (2013), *Operations, administration and maintenance mechanism for MPLS-TP in packet transport networks*
- [ITU-T G.8121] Recommendation ITU-T G.8121/Y.1381 (~~2015~~2013), *Characteristics of MPLS-TP equipment functional blocks*
- ~~[ITU-T G.8113.1] Recommendation ITU-T G.8113.1/Y.1371.1 (2015), *Operations, administration and maintenance mechanism for MPLS-TP in packet transport networks*~~

3 Definitions

3.1 Terms defined elsewhere:

This Recommendation uses the following terms defined elsewhere:

- 3.1.1 access point: [ITU-T G.805]
- 3.1.2 adapted information: [ITU-T G.805]
- 3.1.3 characteristic information: [ITU-T G.805]
- 3.1.4 client/server relationship: [ITU-T G.805]
- 3.1.5 connection: [ITU-T G.805]
- 3.1.6 connection point: [ITU-T G.805]
- 3.1.7 layer network: [ITU-T G.805]
- 3.1.8 network: [ITU-T G.805]
- 3.1.9 network connection: [ITU-T G.805]
- 3.1.10 reference point: [ITU-T G.805]
- 3.1.11 subnetwork: [ITU-T G.805]
- 3.1.12 subnetwork connection: [ITU-T G.805]
- 3.1.13 termination connection point: [ITU-T G.805]
- 3.1.14 trail: [ITU-T G.805]
- 3.1.15 trail termination: [ITU-T G.805]
- 3.1.16 transport: [ITU-T G.805]

- 3.1.17 transport entity: [ITU-T G.805]
- 3.1.18 label: [ITU-T G.8101]
- 3.1.19 label stack: [ITU-T G.8101]
- 3.1.20 MPLS label stack: [ITU-T G.8101]
- 3.1.21 label switched path: [ITU-T G.8101]
- 3.1.22 Bottom of Stack: [ITU-T G.8101]
- 3.1.23 Time To Live: [ITU-T G.8101]
- 3.1.24 Label value: [ITU-T G.8101]
- 3.1.25 Per-Hop Behaviour: [ITU-T G.8101]
- 3.1.26 Associated Channel Header: [ITU-T G.8101]
- 3.1.27 Generic Associated Channel: [ITU-T G.8101]
- 3.1.28 G-ACh Label: [ITU-T G.8101]
- 3.1.29 traffic class: [ITU-T G.8101]

3.2 Terms defined in this Recommendation

This Recommendation defines the following terms:

None

4 Abbreviations and acronyms

This Recommendation uses the following abbreviations and acronyms:

ACH	Associated Channel Header
AI	Adapted Information
AIS	Alarm indication signal
AP	Access Point
APS	Automatic protection switching
CC	Continuity Check
CC/CV	Continuity Check and Connectivity Verification
CCM	Continuity Check Message
CI	Characteristic Information
CoS	Class of Service
CP	Connection Point
CSF	Client Signal Fail
CV	Connectivity Verification
CW	Control Word
DM	Delay Measurement
DP	Drop Precedence
DT	Diagnostic Test
EMF	Equipment Management Function
FP	Flow Point
FTP	Flow termination point
G-ACh	Generic Associated Channel
GAL	G-ACh Label
GFP-F	Frame-mapped Generic Framing Procedure
LCK	Locked

LM	Loss Measurement
LOS	Loss of Signal
LStack	Label Stack
MCC	Maintenance Communication Channel
MEG	Maintenance Entity Group (New)
MEP	Maintenance entity group (MEG) End Point
MIP	Maintenance entity group (MEG) Intermediate Point
MP	Management Point
MPLS	Multi-Protocol Label Switching
MPLS-TP	Multi-Protocol Label Switching - Transport Profile
MT	Multi-Protocol Label Switching - Transport Profile
MTDe	MPLS-TP MEP Diagnostic function
MTDi	MPLS-TP MIP Diagnostic function
OAM	Operation, Administration and Maintenance
PDU	Protocol Data Unit
PHB	Per Hop Behaviour
PW	Pseudowire
PSC	PHB Scheduling Class
RDI	Remote Detect Indication
RI	Remote Information
RP	Remote Point
RT	Route Trace
SCC	Signalling Communication Channel
TCP	Termination Connection Point
TFP	Termination Flow Point
TH	Throughput
TTL	Time-To-Live
PM	Performance Monitoring
SSF	Server Signal Fail
TC	Traffic Class
TLV	Type Length Value
TSD	Trail Signal Degrade
TSF	Trail Signal Fail

5 Conventions

The diagrammatic convention for connection-oriented layer networks described in this Recommendation is that of [ITU T G.805].

In this Recommendation, MI_LMC_Enable and MI_LML_Enable are used to mean MI_1LMp_Enable and MI_LMp_Enable as described in [ITU-T G.8121].

6 Supervision

The generic supervision functions are defined in clause 6 in [ITU-T G.806]. Protocol neutral supervision functions for the MPLS-TP network are defined in this clause 6 in [ITU-T G.8121]. Specific supervision functions for the MPLS-TP network are defined in this clause.

6.1 Defects

The defect Entry and Exit conditions are based on events. Occurrence or absence of specific events may raise or reset specific defects.

The events used by this recommendation are defined in Table 6-1 in [ITU-T G.8121].

6.2 Consequent actions

For generic consequent actions, see [ITU-T G.806]. For the specific consequent actions applicable to MPLS-TP, refer the specific atomic functions.

6.3 Defect correlations

For the defect correlations, see the specific atomic functions.

6.4 Performance filters

For further study

7 Information flow across reference points

Information flow for MPLS-TP functions is defined in clause 9. A generic description of information flow is defined in clause 7 in [ITU-T G.806].

8 MPLS-TP processes

8.1 G-ACh Process

See the clause 8.1 in [ITU-T G.8121]

8.2 TC/Label processes

See the clause 8.2 in [ITU-T G.8121]

8.3 Queuing process

See the clause 8.3 in [ITU-T G.8121]

8.4 MPLS-TP-specific GFP-F processes

See the clause 8.4 in [ITU-T G.8121]

8.5 Control Word (CW) processes

See the clause 8.5 in [ITU-T G.8121]

8.6 OAM related Processes used by Server adaptation functions

8.6.1 Selector Process

See the clause 8.6.1 [ITU-T G.8121]

8.6.2 AIS (Alarm Reporting) Insert Process

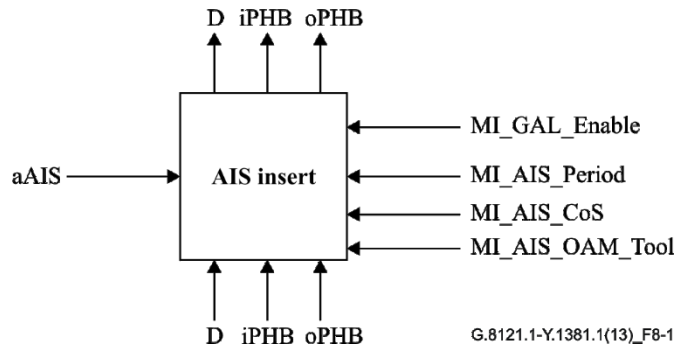

Figure 8-1/G.8121.1/Y.1381.1 – AIS Insert process

Figure 8-1 shows the AIS Insert Process Symbol as shown in Figure 8-13 of [ITU-T G.8121] and Figure 8-2 defines the behaviour. If the aAIS signal is true, the AIS Insert process continuously generates MT_CI traffic units where the MT_CI_D signal contains the AIS signal until the aAIS signal is false. The generated AIS traffic units are inserted in the incoming stream, i.e., the output stream contains the incoming traffic units and the generated AIS traffic units.

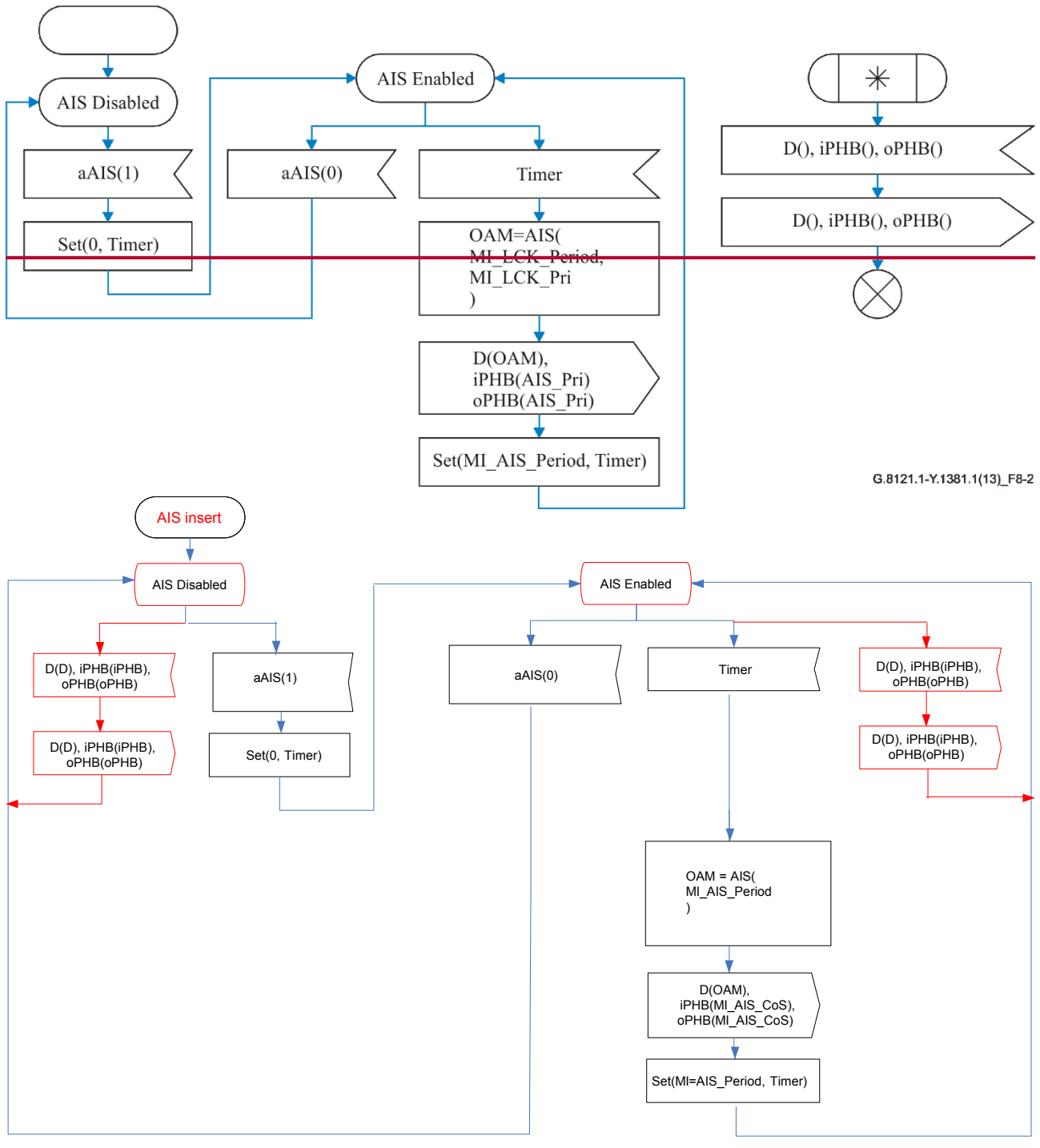

Figure 8-2/G.8121.1/Y.1381.1 – AIS Insert behaviour

The period between consecutive AIS traffic units is determined by the MI_AIS_Period parameter. Allowed values are once per second and once per minute; the encoding of these values is defined in Table 8-1. Note that these encoding are the same as for the LCK generation process.

Table 8-1/G.8121.1/Y.1381.1 – AIS period values

3-bits	Period Value	Comments
000-011	Invalid Value	Invalid value for AIS PDUs
100	1s	1 framepacket per second
101	Invalid Value	Invalid value for AIS PDUs
110	1 min	1 framepacket per minute
111	Invalid Value	Invalid value for AIS PDUs

The MT_CI_D signal contains an M_SDU field. The format of the M_SDU field for AIS traffic units is defined in [ITU-T G.8113.1].

The periodicity (as defined by MI_AIS_Period) is encoded in the three least significant bits of the Flags field in the AIS PDU using the values from Table 8-2.

8.6.3 LCK (Lock Reporting) Generate Process

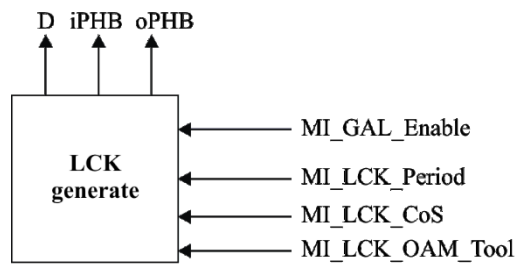

G.8121.1-Y.1381.1(13)_F8-3

Figure 8-3/G.8121.1/Y.1381.1 – LCK Generation process

Figure 8-3 shows the LCK Generate Process Symbol as shown in Figure 8-14 of [ITU-T G.8121]. The LCK Generation Process generates MT_CI traffic units where the MT_CI_D signal contains the LCK signal. Figure 8-4 defines the behaviour of the LCK Generation Process as shown in Figure 8-15 of [ITU-T G.8121].

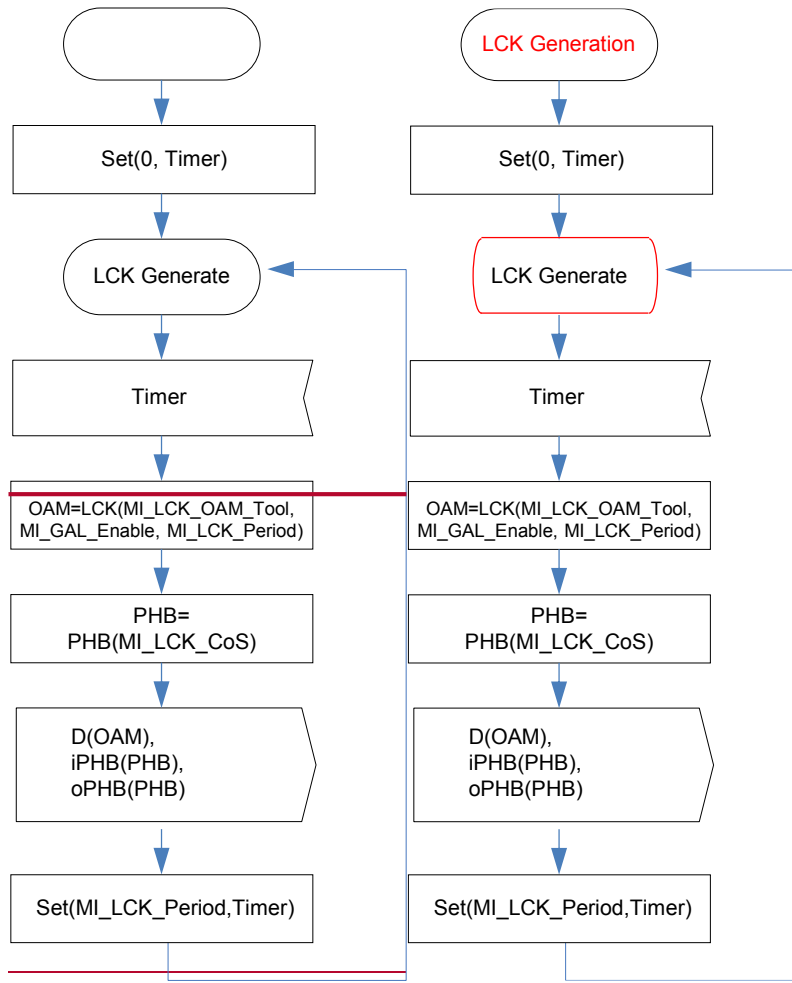

Figure 8-4/G.8121.1/Y.1381.1 – LCK Generation behaviour

[The block of “OAM=...” is not blue and italic]

The LCK Generation Process continuously generates LCK Traffic Units; every time the Timer expires a LCK Traffic Unit will be generated. The period between two consecutive traffic units is determined by the MI_LCK_Period input signal. Allowed values are defined in Table 8-2.

Table 8-2/G.8121.1/Y.1381.1 – LCK period values

3-bits	Period Value	Comments
000-011	Invalid Value	Invalid value for LCK PDUs
100	1s	1 framepacket per second
101	Invalid Value	Invalid value for LCK PDUs
110	1 min	1 framepacket per minute
111	Invalid Value	Invalid value for LCK PDUs

The MT_CI_D signal contains an M_SDU field. The format of LCK units is defined in [ITU-T G.8113.1].

The periodicity (as defined by MI_LCK_Period) is encoded in the three least significant bits of the Flags field in the LCK PDU using the values from Table 8-1.

The value of the MT_CI_PHB signal associated with the generated LCK traffic units is defined by the MI_LCK_CoS input parameter.

8.7 OAM related Processes used by adaptation functions

8.7.1 MCC/SCC Mapping Insert and De-mapping Process

See the clause 8.7.1 in [ITU-T G.8121]

8.7.2 APS Insert and Extract Process

See the clause 8.7.2 in [ITU-T G.8121]

8.7.3 CSF Insert and Extract Process

See the clause 8.7.3 in [ITU-T G.8121]

8.8 Pro-active and on-demand OAM related Processes

8.8.1 Proactive Continuity Check and Connectivity Verification (CC/CV)

8.8.1.1 Overview

To support CC/CV, the Continuity Check Message (CCM) as described in [ITU-T G.8113.1] clause 8.2.1 is used.

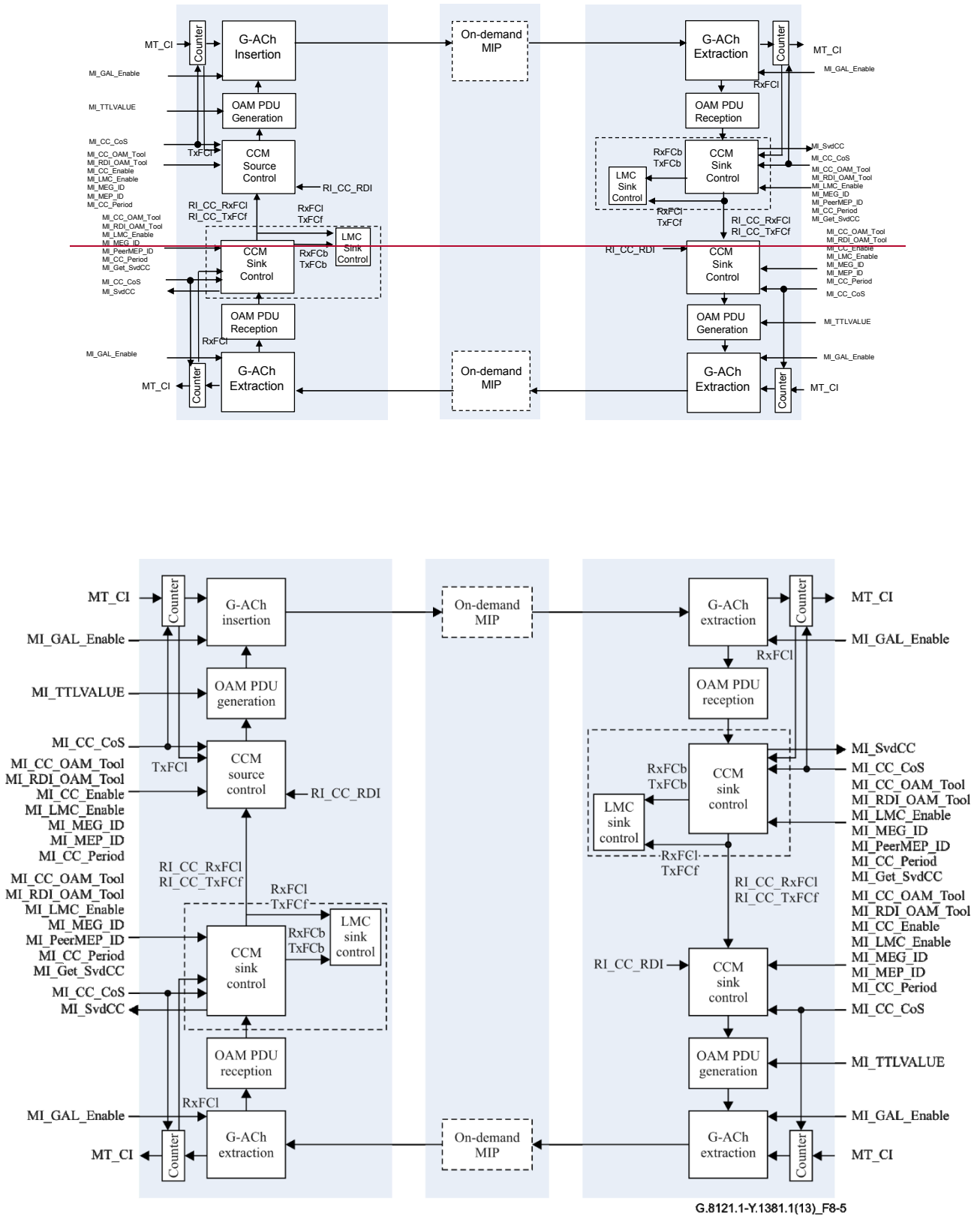

Figure 8-5/G.8121.1/Y.1381.1 – Overview of Processes involved with CCM

Figure 8-5 provides an overview of the processes that support the CC/CV function by using CCM. The CCM Generation process generates the CCM framepackets if MI_CC_Enable is true. The

MI_MEG_ID and MI_MEP_ID are the MEG and MEP IDs of the MEP itself and these IDs are carried in the CCM [framepacket](#). The CCM [framepackets](#) are generated with a periodicity determined by MI_CC_Period and with a priority determined by MI_CC_CoS. If MI_LMC_Enable is set, the CCM [framepackets](#) will also carry Loss Measurement information. The Generated CCM Traffic Units are inserted in the flow of MT_CI by the OAM MEP Source Insertion Process. MI_MEP_ID contains an integer value in the range 1-8191.

The CCM [framepackets](#) pass transparently through MIPs.

The OAM MEP Sink Extraction process extracts the CCM Unit from the flow of MT_CI and the CCM Reception process processes the received CCM Traffic Unit. It compares the received MEG ID with the provisioned MI_MEG_ID, and the received MEP_ID with the provisioned MI_PeerMEP_ID; this contains the list of all expected peer MEPs in the MEG. Based on the processing of this [framepacket](#) one or more events may be generated that serve as input for the Defect Detection Process (not shown in Figure 8-5).

RDI information is carried in the CCM [framepacket](#) based upon the RI_CC_RDI input. It is extracted in the CCM Reception Process.

8.8.1.2 CCM Generation Process

Figure 8-6 describes the behaviour for the CCM Generation Process.

This process generates MPLS-TP CI traffic units where MT_CI_D signal contains the CCM traffic units for pro-active monitoring and counts all data [framepackets](#) with PHB equal to MI_CC_CoS (TxPCI).

The D, iPHB and oPHB signal are forwarded unchanged as indicated by in Figure 8-6

The CCM Generation process can be enabled and disabled using the MI_CC_Enable signal.

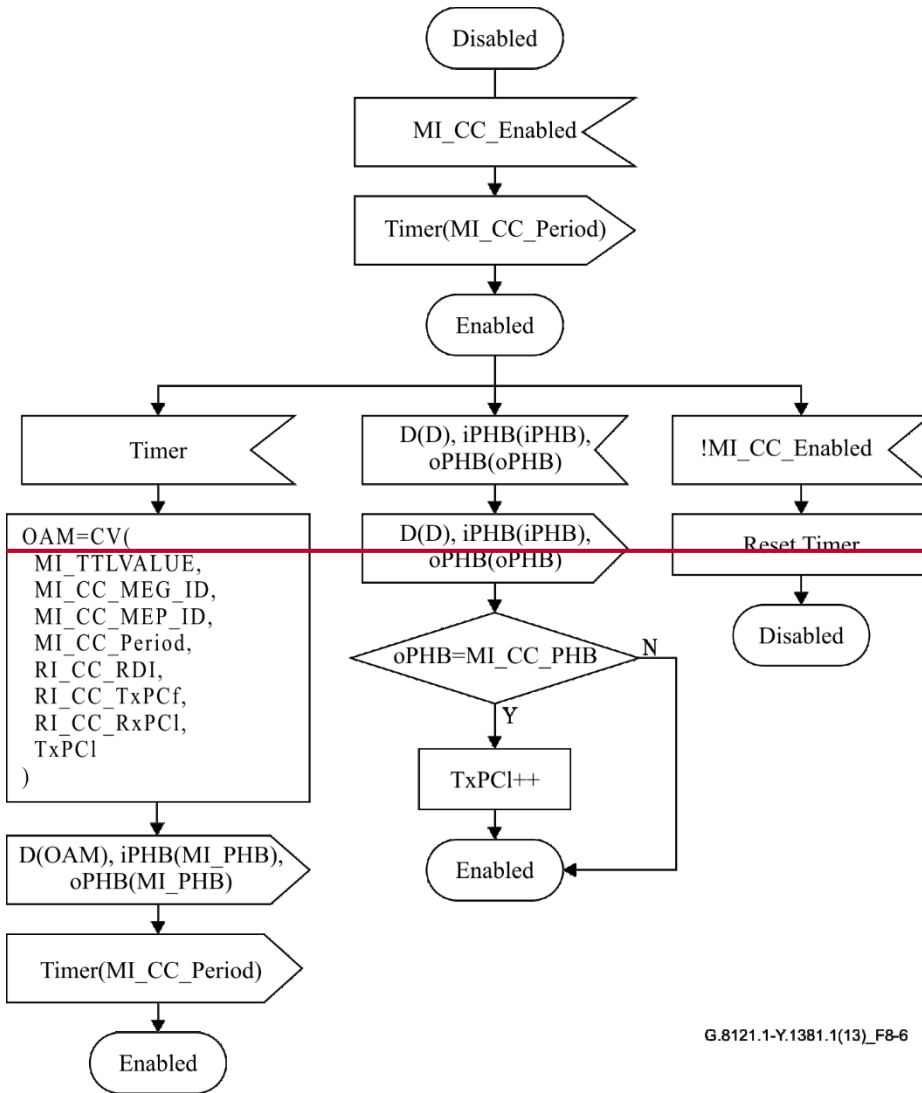

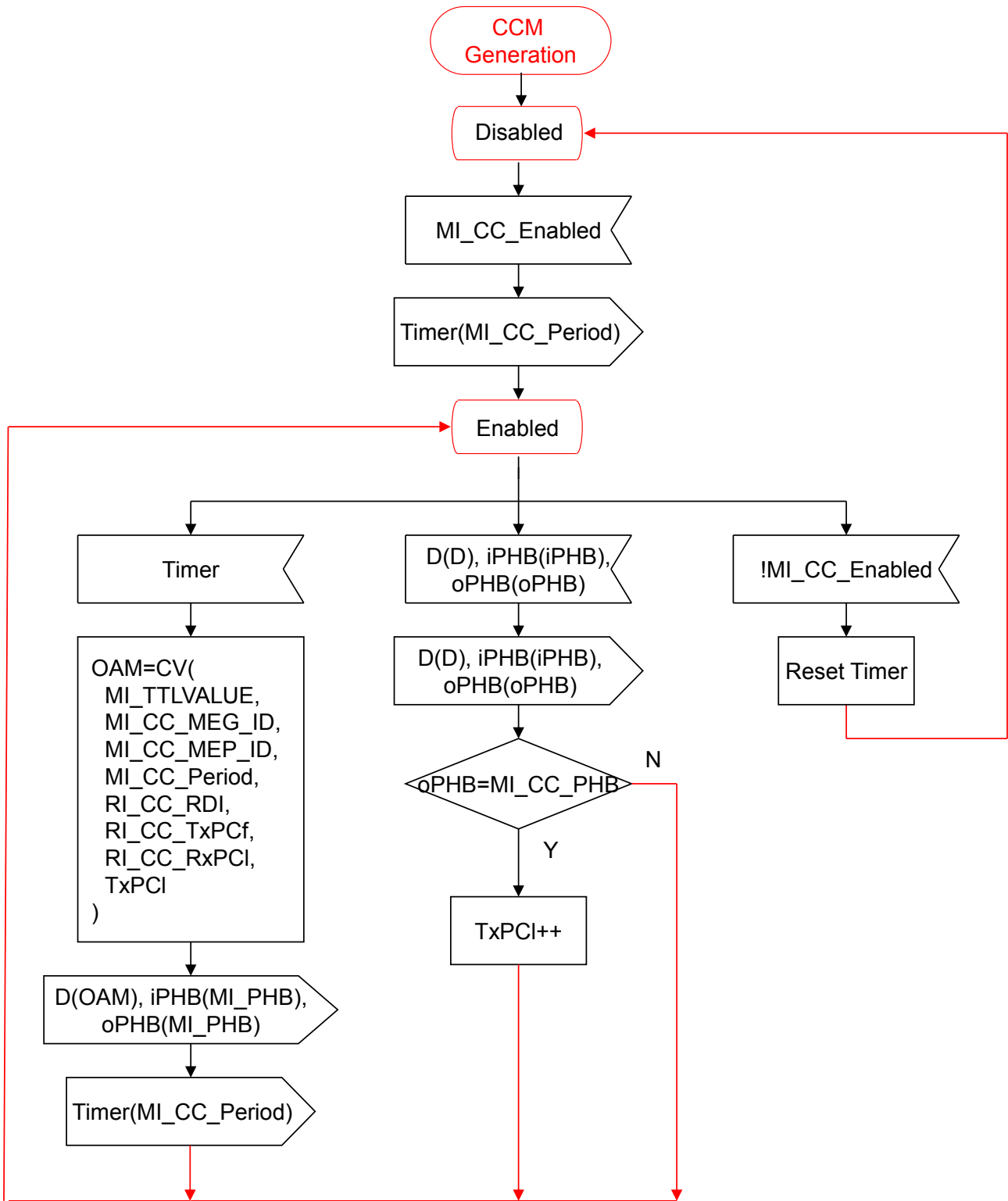

Figure 8-6/G.8121.1/Y.1381.1 – CCM Generation process

The period between the generating consecutive CCM traffic units is determined by the MI_CC_Period parameter. Allowed values and the encoding of these values are defined in Table 8-3.

Table 8-3/G.8121.1/Y.1381.1 – CCM Period Values

MI_CV_Period	Period Value	Comments
000	Invalid Value	Invalid value for CC-V PDUs
001	3.33ms	300 <u>framepackets</u> per second
010	10ms	100 <u>framepackets</u> per second
011	100ms	10 <u>framepackets</u> per second
100	1s	1 <u>framepacket</u> per second
101	10s	6 <u>framepackets</u> per minute
110	1 min	1 <u>framepacket</u> per minute
111	10 min	6 <u>framepacket</u> per hour

8.8.1.3 CCM Reception Process

Figure 8-7 describes the behaviour for the CCM Reception Process.

The CCM reception process transparently forwards all the data framepackets and counts all data framepackets that have PHB (per-hop behaviour) equal to MI_CC_CoS.

Furthermore the CCM reception process processes received CCM OAM traffic units. It checks the various fields of the OAM PDU and generates the corresponding events (as defined in clause 6).

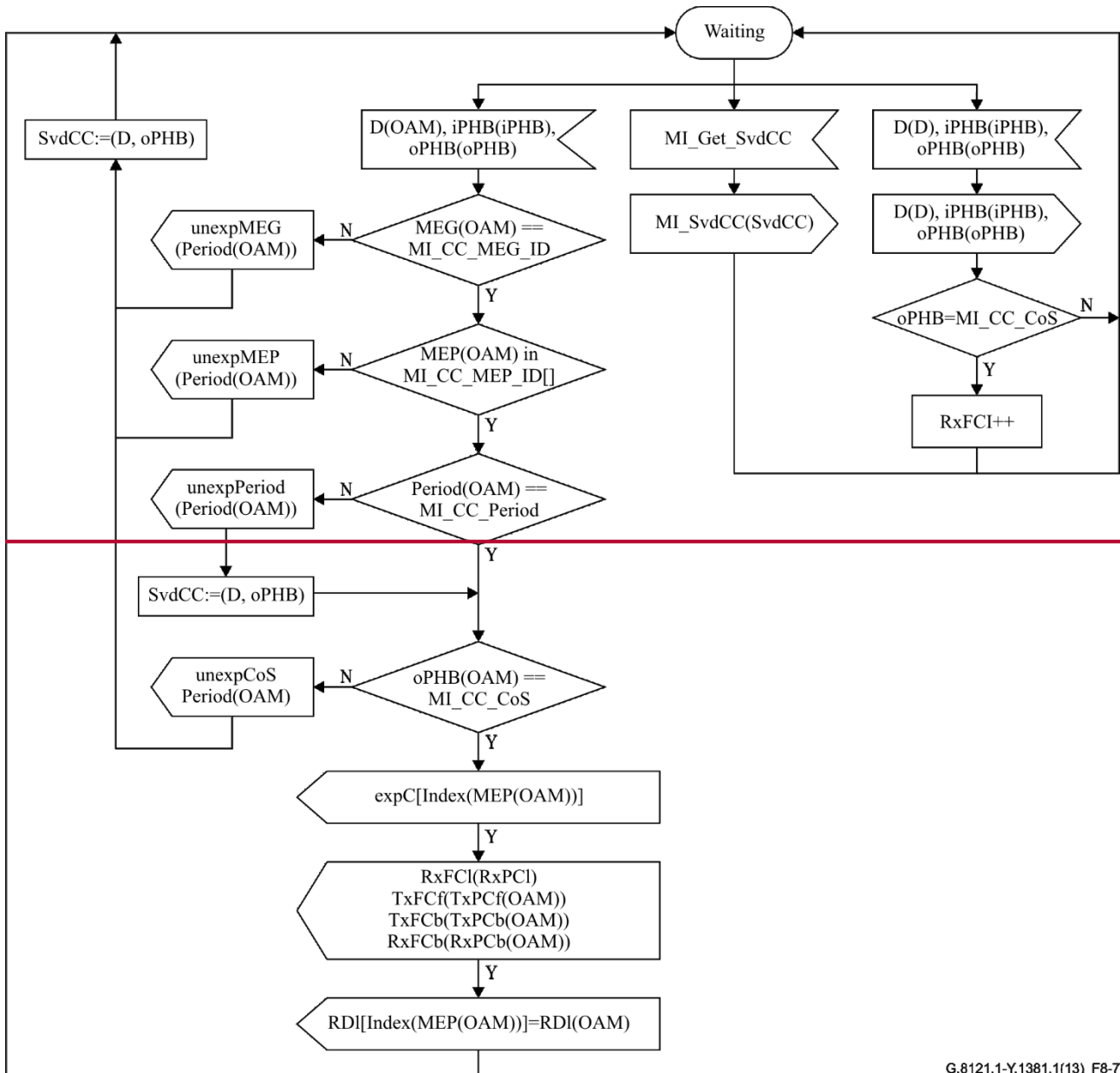

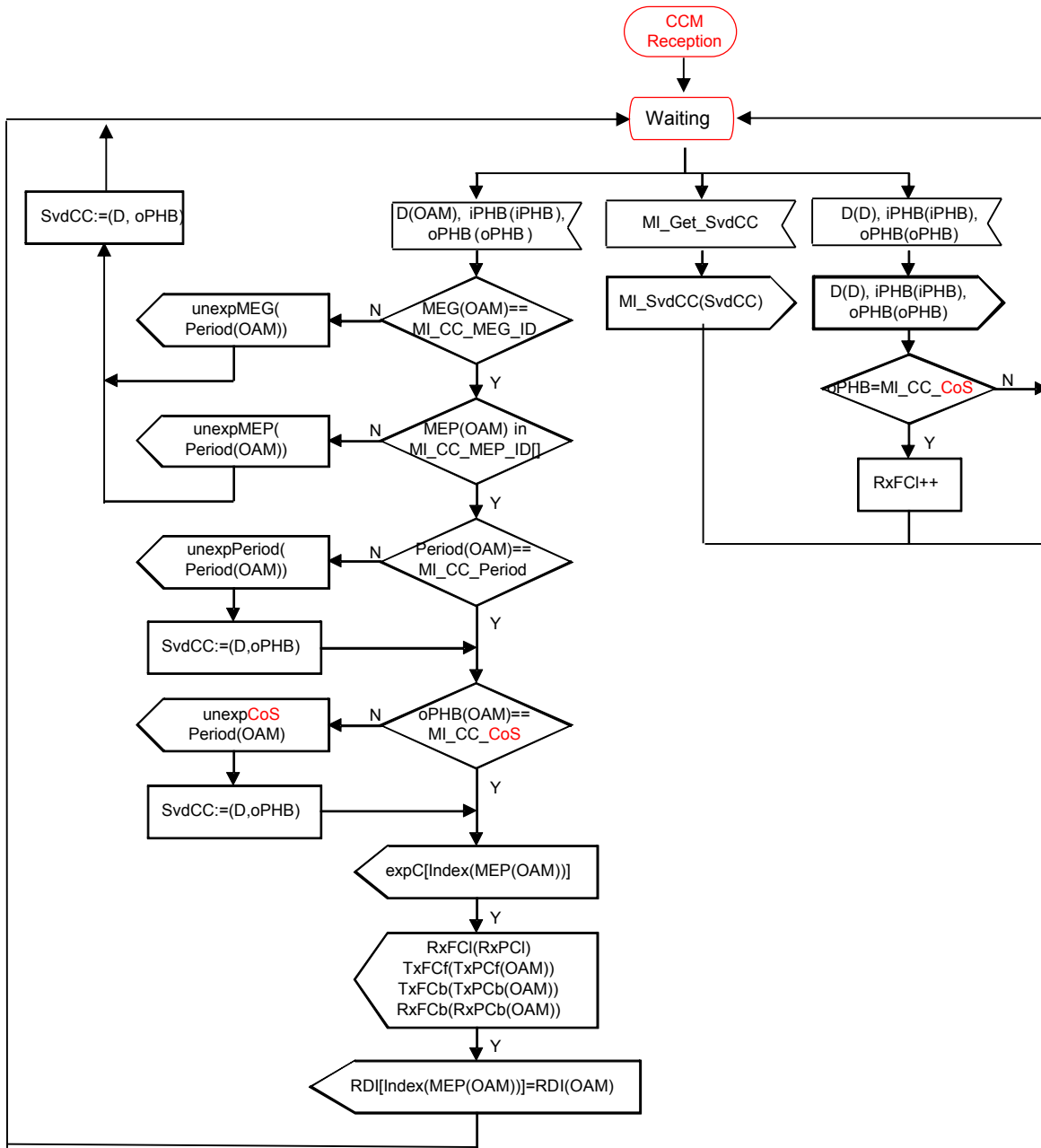

Figure 8-7/G.8121.1/Y.1381.1 – CCM Reception process

8.8.1.4 Counter process

For further study

8.8.1.48.8.1.5 ProActive-Proactive Loss Measurement (LMp) Process

Figure 8-8 shows proactive LM Process behaviour by CCM. This process calculates the number of transmitted and lost framepackets per second.

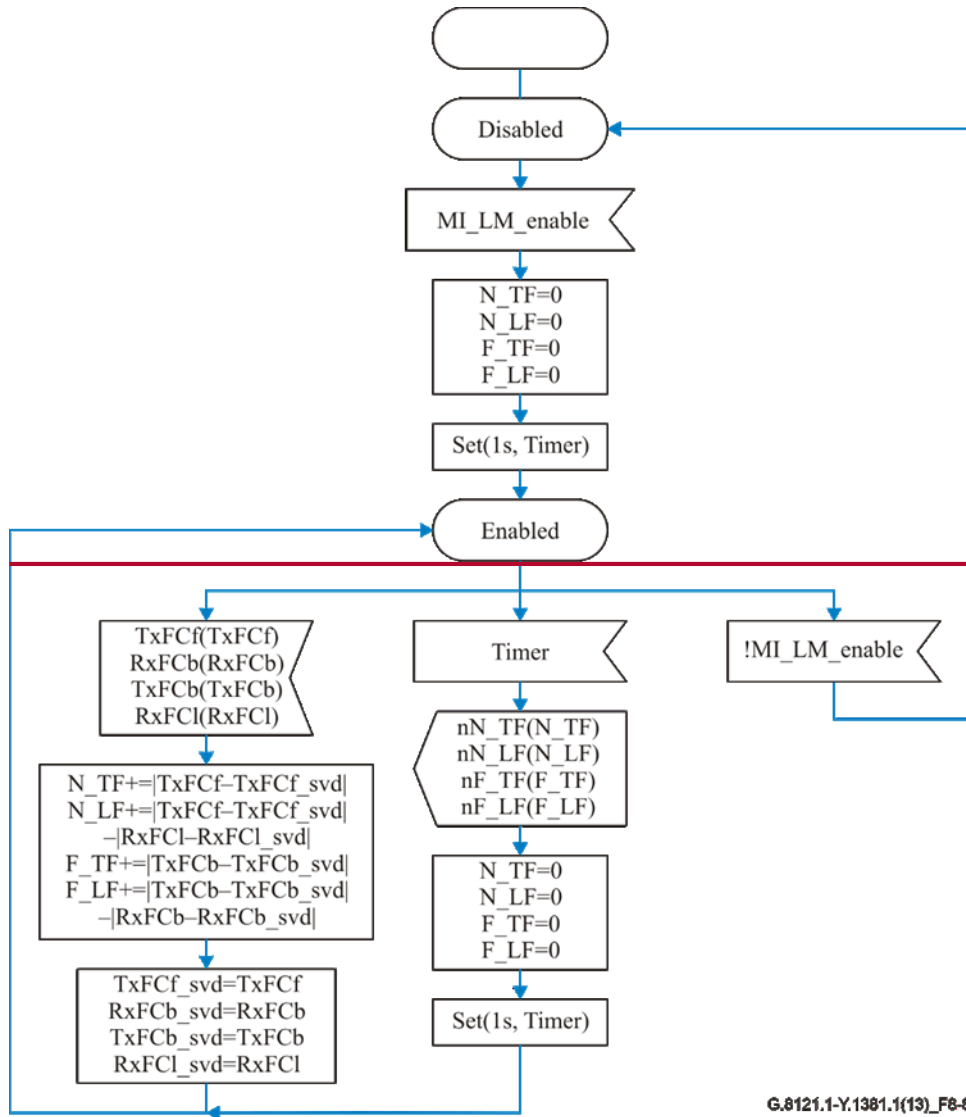

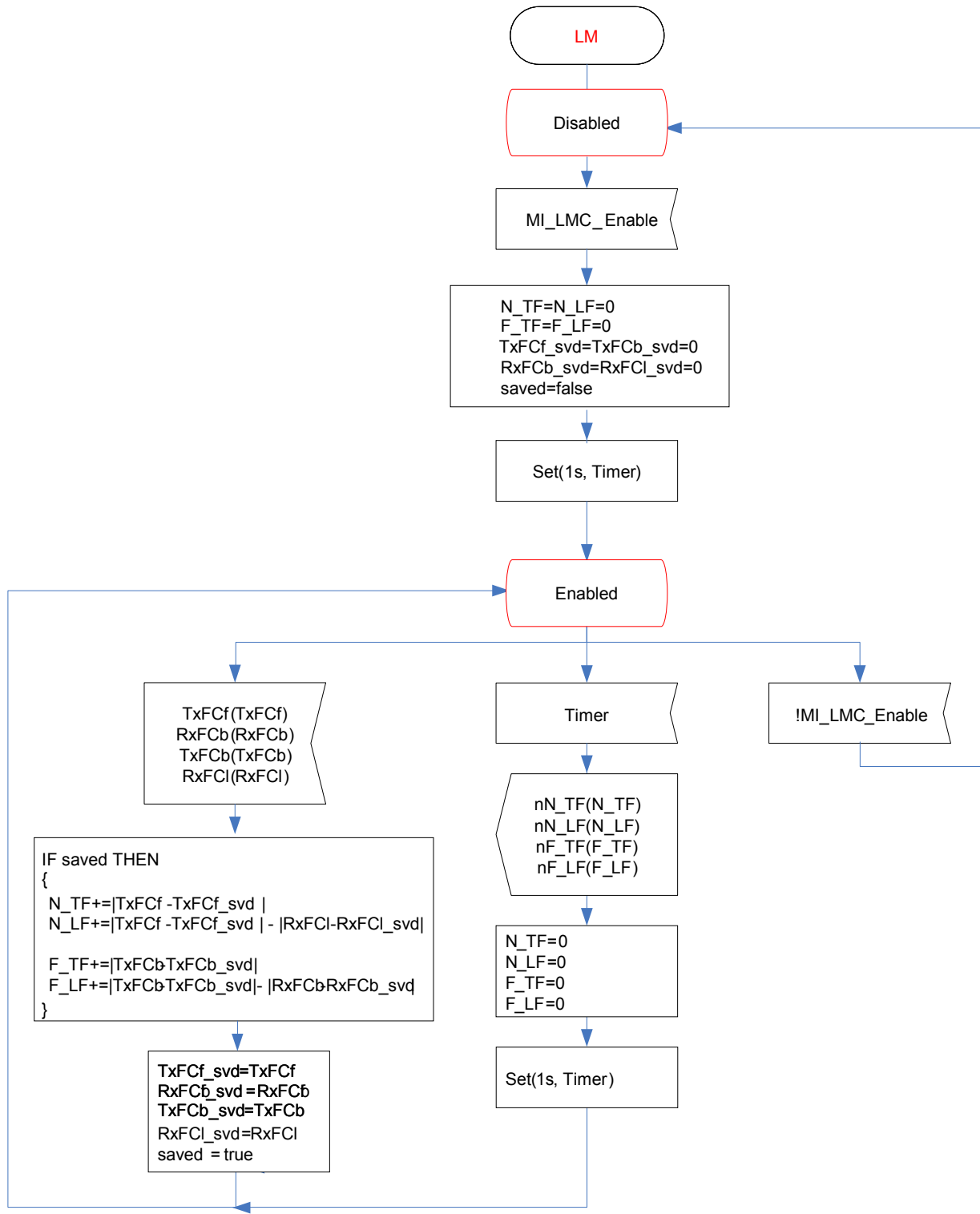

Figure 8-8/G.8121.1/Y.1381.1– LM Process behaviour

8.8.2 Remote Defect Indication (RDI)

As described in clause 8.8.2 in [ITU-T G.8121], RDI information associated with proactive CC/CV and carried in the CC/CV packets based upon the RI_CC/CV_RDI input.

See clause 8.8.1 for further information. As shown in Figure 8-5, RDI information associated with proactive CCM and carried in the CCM packets based upon the RI_CC_RDI input

8.8.3 On-demand Connectivity Verification (CV)

8.8.3.1 Overview

To support on-demand CV, Loopback (LBM/LBR) as described in [ITU-T G.8113.1] clause 8.2.2 is used.

Figure 8-9 provides the different processes inside MEPs and MIPs that are involved in the Loopback Protocol.

The MEP On-Demand OAM Source insertion process is defined in clause 9.4.1.1, the MEP On-Demand OAM Sink extraction process in clause 9.4.1.2, the MIP On-Demand OAM Sink Extraction process in clause 9.4.1.2, and the MIP On-Demand OAM Source insertion process in clause 9.4.2. In summary, they insert and extract MT_CI OAM signals into and from the stream of MT_CI_D Traffic Units. The other processes are defined into this clause.

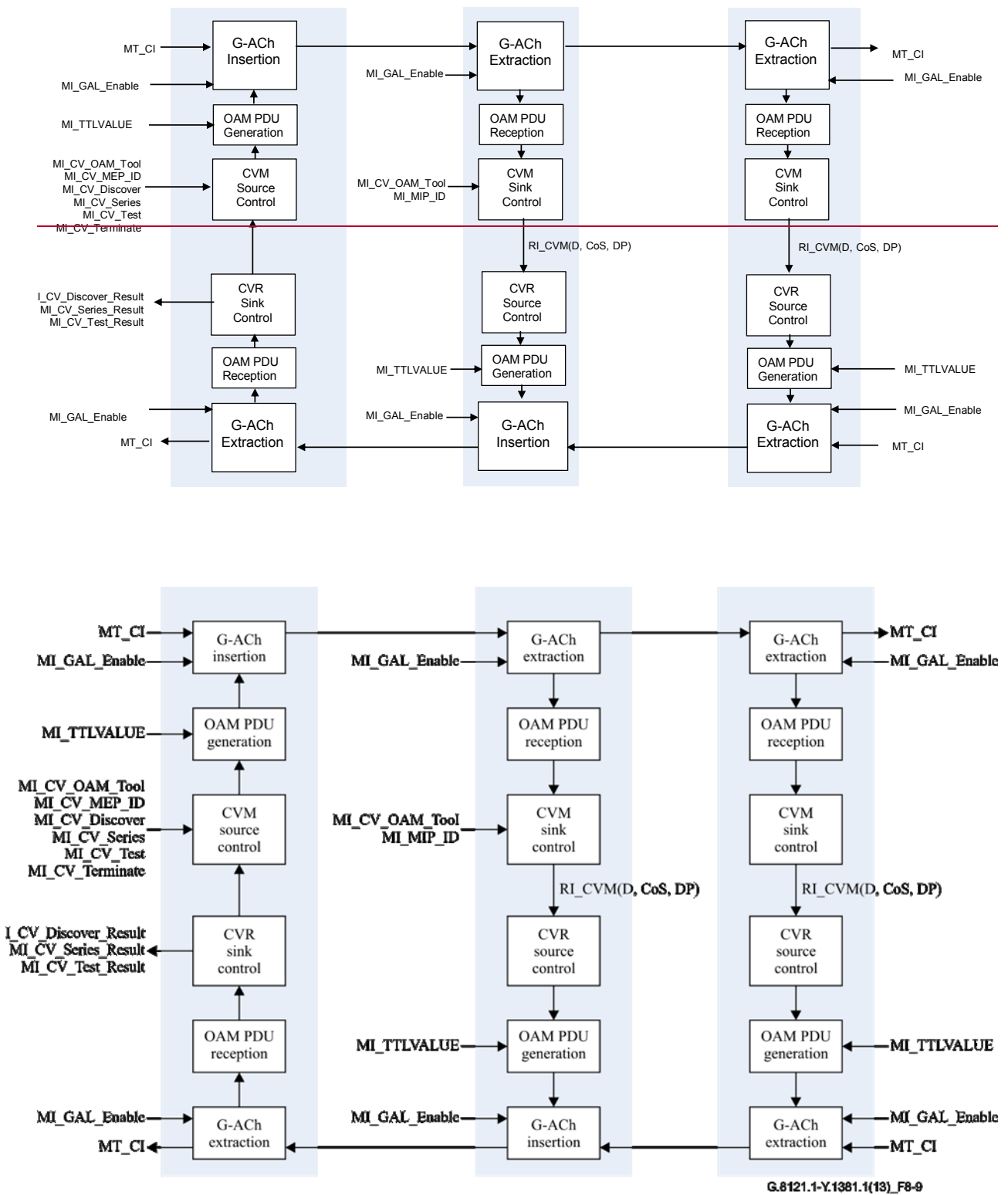

Figure 8-9/G.8121.1/Y.1381.1 – Overview of Processes involved with on-demand CV

The on-demand CV Protocol is controlled by the CVM and CMR Control Processes. Two MI signals that can trigger the LB protocol are defined below:

- MI_CV_Series(CoS,N,Length,Period): To send a series of N LB messages to a particular MEP/MIP; these LB messages are generated every 'Period'.
- MI_CV_Test(CoS,Pattern,Length,Period): To send a series of LB messages carrying a Test Pattern to a particular MEP; these LB messages are generated every 'Period' until the MI_CV_Test_Terminate signal is received. **The CoS parameter is used to set the PHB, and the Length and Pattern specify the length of the packet and the pattern to use.**

The details are described later in this clause.

The CVM Source Control processes to a generated LBM Traffic Unit that is received and forwarded by MIPs and received by MEPs in the same MEG. The CVM Control process controls the number of LBM generated and the period between consecutive LBM Traffic Units.

The CVM MIP/MEP Sink control processes the received LBM Traffic Units and as a result the LBR Generation Process may generate an LBR Traffic Unit in response. The LBR Reception Process receives and processes the LBR Traffic Units..

The CVM Sink Control processes these received values to determine the result of the requested LB operation. The result is communicated back using the following MI signals:

- MI_CV_Series_Result(REC, ERR, OO): Reports back the total number of received LBR **framepackets** (REC), as well as counts of specific errors (ERR):
 - OO: Number of LBR Traffic Units that were received out of order (OO).
- MI_CV_Test_Result(Sent, REC, CRC, BER, OO): Reports back the total number of LBM **framepackets** sent (Sent) as well as the total number of LBR **framepackets** received (REC); for the latter counts of specific errors are reported:
 - CRC: Number of LBR **framepackets** where the CRC in the pattern failed.
 - BER: Number of LBR **framepackets** where there was a bit error in the pattern.
 - OO: Number of LBR **framepackets** that were received out of order.

The detailed functionality of the various processes is defined below.

8.8.3.2 CVM Source Control Process

The CVM Source Control Process can receive several MI signals to trigger the LB protocol; this is shown in Figure 8-10.

Note: CV Control behaviour for Test is for further study.

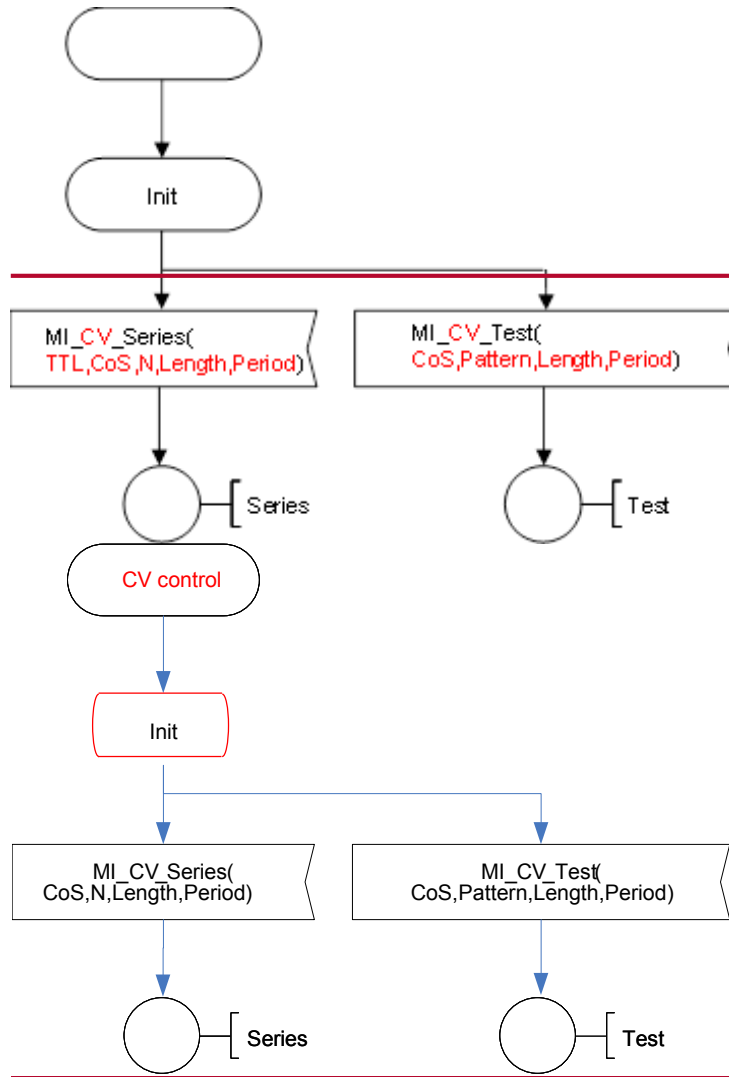
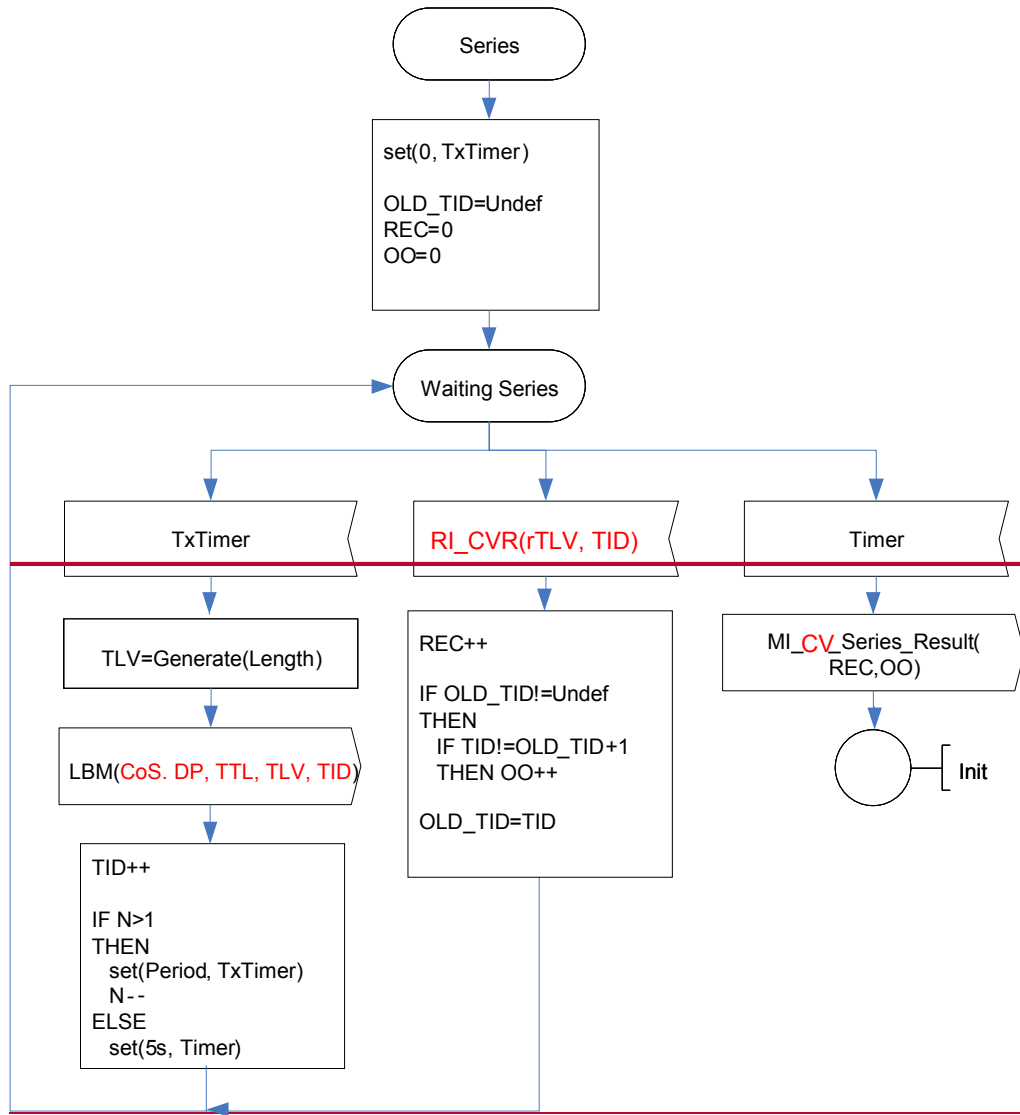

Figure 8-10/G.8121.1/Y.1381.1 –CV Control Behaviour



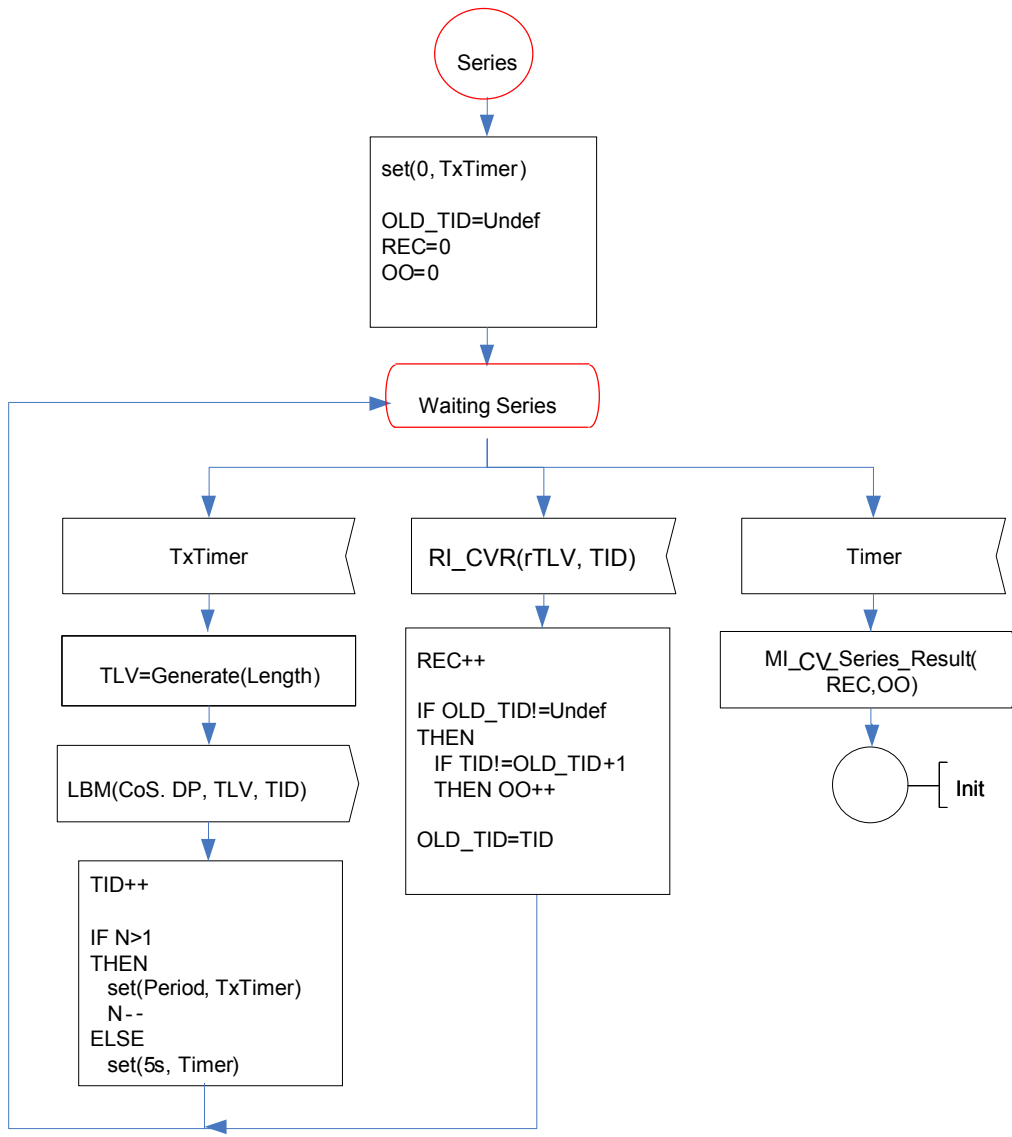

Figure 8-11/G.8121.1/Y.1381.1 – CV Control Series Behaviour

Figure 8-11 defines the behaviour of the LB Control Process after the reception of the MI_CV_Series(~~TTL~~, DP, CoS, N, Length, Period) signal.

The TLV field of the LBM **framepacket**s is determined by the Generate(Length) function. Generate(Length) generates a Data TLV with length ‘Length’ of arbitrary bit pattern to be included in the LBM **framepacket**.

After the receipt of the MI_CV_Series signal, the LBM Generation Process is requested N times to generate an LBM **framepacket** (where Period determines the interval between two LBM **framepacket**s); this is done by issuing the LBM(D, DP, CoS, TLV, TID) signal.

Whenever an RI_CV(rTLV, TID) signal is received, the number of received LBR **framepacket**s is increased (REC++). If the TID value from the RI_LBR signal does not consecutively follow the last received TID value, the counter for out of order **framepacket**s is incremented by one (OO++).

Five seconds after sending the last LBM **framepacket** (i.e., after sending the Nth LBM **framepacket**) the REC and OO counters are reported back in the MI_CV_Series_Result signal.

8.8.3.3 CVM Generation Process

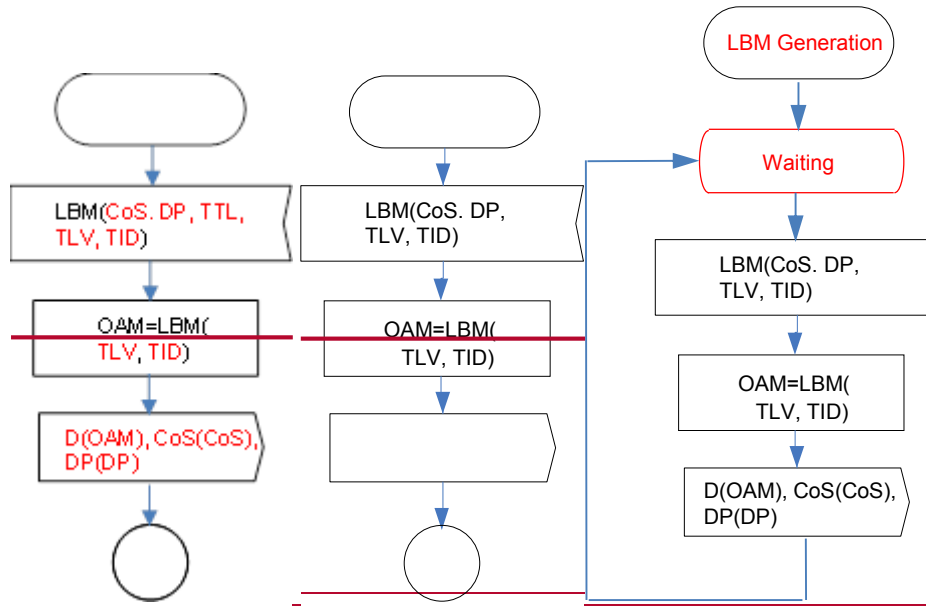
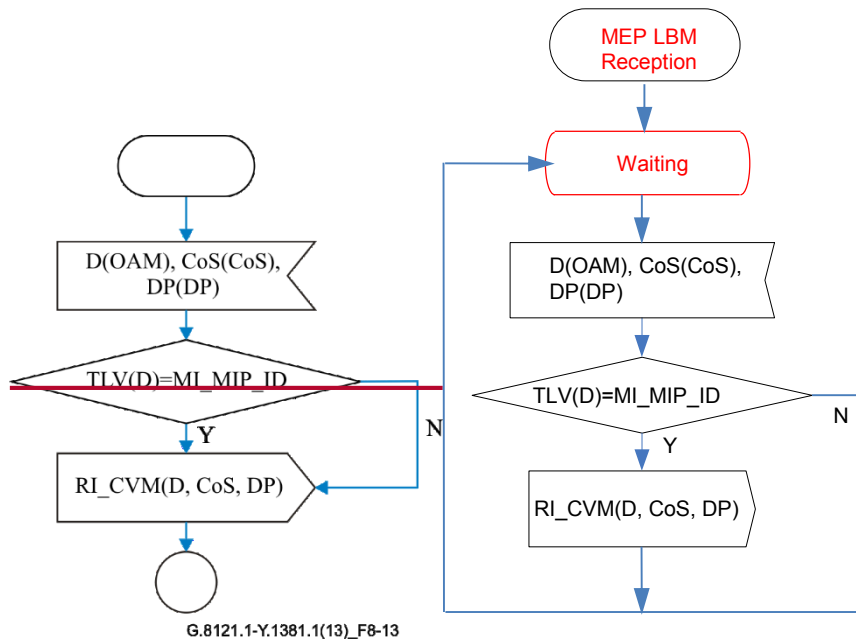

Figure 8-12/G.8121.1/Y.1381.1 – MEP LBM Generation Behaviour

The CVM Generation process that is in CVM Source Control Process generates a *single* LBM OAM Traffic Unit (MT_CI_D) complemented with MT_CI_CoS and MT_CI_DP signals on receipt of the LBM() signal. The process is defined in Figure 8-12.

From the LBM() signal the CoS field determines the value of the MT_CI_CoS signal, the DP field determines the value of the MT_CI_DP signal. The TLV and TID fields are used in the construction of the MT_CI_D signal that carries the LBM Traffic Unit.

8.8.3.4 MIP CVM Sink Control Process



G.8121.1-Y.1381.1(13)_F8-13

Figure 8-13/G.8121.1/Y.1381.1 – MIP LBM Reception Behaviour

The MIP CVM Sink Control Process receives MT_CI Traffic Units containing LBM PDUs complemented by the P and D signals.

The behaviour is defined in Figure 8-13. If TLV(D) equals MI_MIP_ID, the Loopback is intended for this MIP and the information is forwarded to the Loopback Reply Generation Process using the RI_CVM(D,DP,CoS) signal; otherwise the information is ignored and no action is taken.

8.8.3.5 MEP CVM Sink Control Process

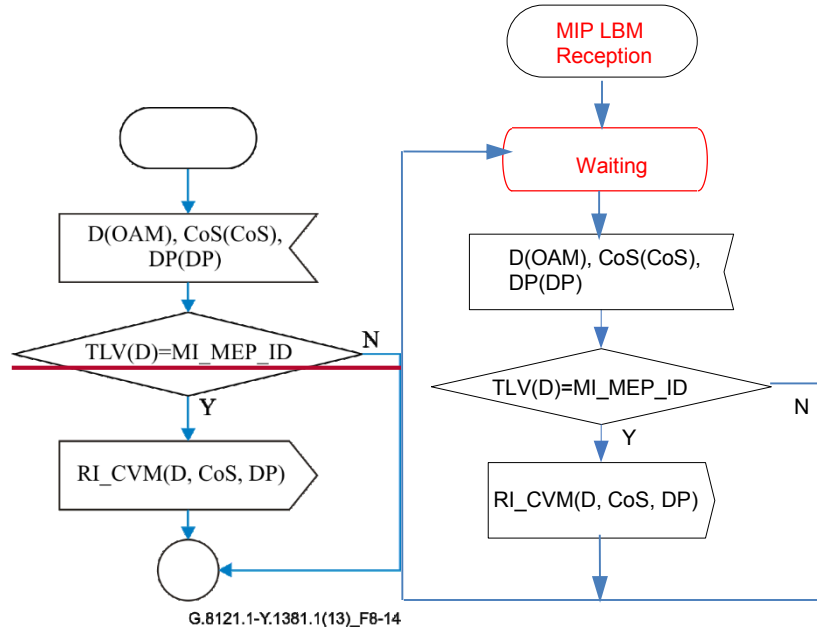

Figure 8-14/G.8121.1/Y.1381.1 – MEP LBM Reception Behaviour

The MEP CVM Sink Control Process receives MT_CI Traffic Units containing LBM PDUs complemented by the CoS and D signals.

The behaviour is defined in Figure 8-14.

If the TLV field in the LBM Traffic Unit (D signal) equals the MI_MEP_ID, the Loopback is intended for this MEP, and the information is forwarded to the Loopback Reply Generation Process (RI_LBMCVM(D,CoS,DP)).

8.8.3.6 CVR Source Control Process

Note that the ~~CVRLCMR~~ Source Control Process is the same for MEPs and MIPs.

Upon receipt of the LBM Traffic Unit and accompanying signals (RI_LBMCVM(D,P,DE)) from the LBM reception process the LBR Generation Process generates an LBR Traffic Unit together with the complementing P and DE signals.

The generated traffic unit is the same as the received RI_LBMCVM(D) Traffic Unit except:

- the Opcode is set to LBR opcode.

8.8.3.7 CVR Sink Control Process

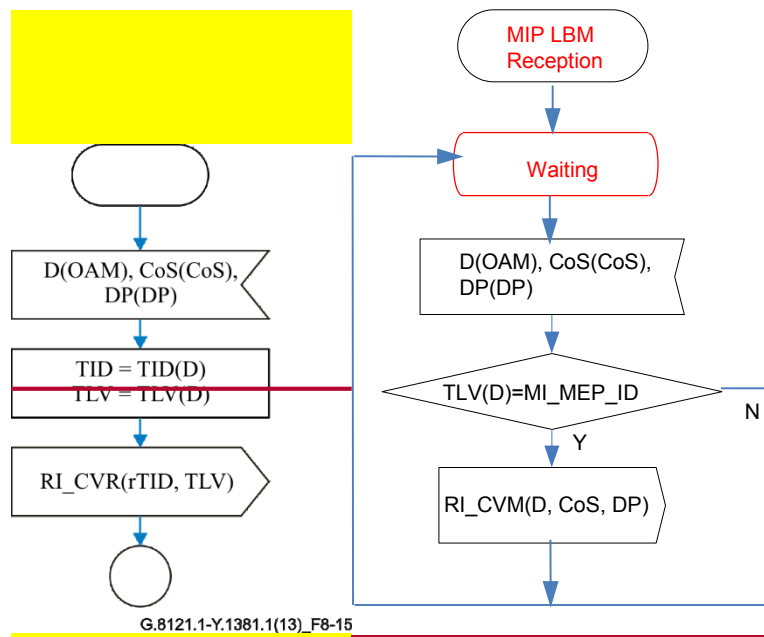

Figure 8-15/G.8121.1/Y.1381.1 –LBR Reception Behaviour

The CVR Sink Control receives LBR Traffic Units (D signal) together with the complementing CoS and signals. The LBR Reception process will inspect the received Traffic Unit; if the traffic units is valid, TID and TLV values will be extracted from the LBR PDU and signalled to the CV Control Process using the RI_CVR(TID,TLV) signal. The behaviour is defined in Figure 8-15.

8.8.4 Proactive Packet Loss Measurement (LMp)

~~This functionality is defined in [ITU-T G.8113.1] only by using CCM. See clause 8.8.1.4~~

8.8.4.1 Overview

To support this functionality, Proactive Loss Measurement (LMM/LMR) as described in [ITU-T G.8113.1] clause 8.2.6 or proactive packet loss measurement by using CCM is used. The proactive packet loss measurement by CCM is described in clause 8.8.1.4

Figure 8-xx provides the different processes inside MEPs and MIPs that are involved in the Loss Measurement Protocol for Proactive Loss Measurement (LMM/LMR).

The MEP proactive OAM insertion process is defined in clause 9.2.1.1, the MEP OAM proactive extraction process in clause 9.2.1.2. In summary, they insert and extract MT_CI_OAM signals into and from the stream of MT_CI_D traffic units and the complementing CoS and D signals going through an MEP and MIP..

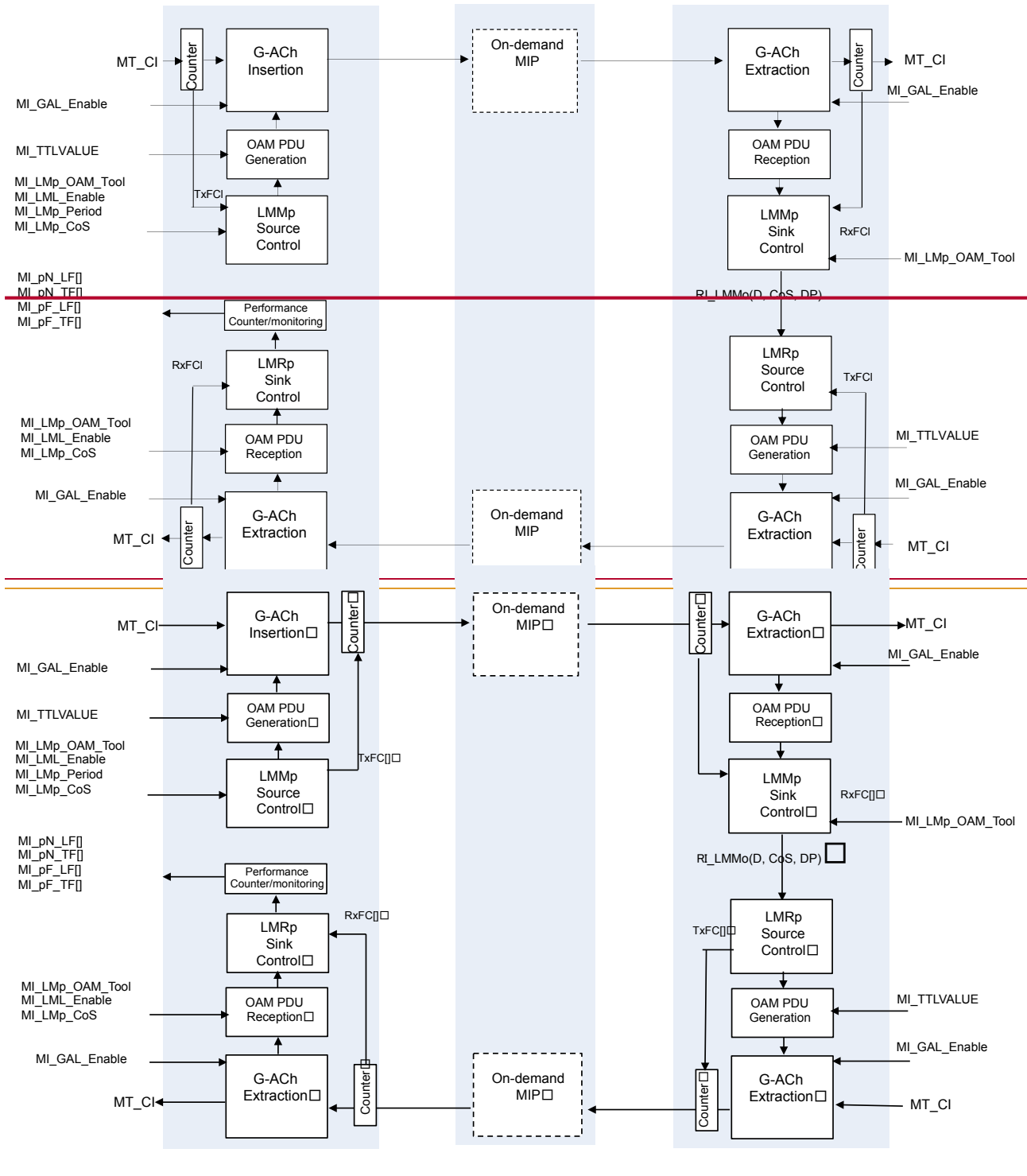

Figure 8-xx/G.8121.1/Y.1381.1 – Overview of processes involved with proactive loss measurement

The proactive LM control process controls the proactive LM protocol. If MI_LML_Enable is set the LMM framepackets are sent periodically. The LMM framepackets are generated with a periodicity determined by MI_LMp_Period and with a priority determined by MI_LMp_CoS. The result (N_TF, N_LF, F_TF, F_LF) is reported via an LMRp reception. If the proactive LM control process activates the multiple monitoring on different CoS levels simultaneously, each result is independently managed per CoS level.

The behaviour of the processes is defined below.

8.8.4.2 Proactive LM Source Control Process

The behaviour of the proactive LM control process is defined in Figure 8-xx+1. If the MI_LML_Enable is asserted, the process starts to generate LMM ~~frame~~packets. The result (N_TF, N_LF, F_TF, F_LF) is reported via an LMR reception.

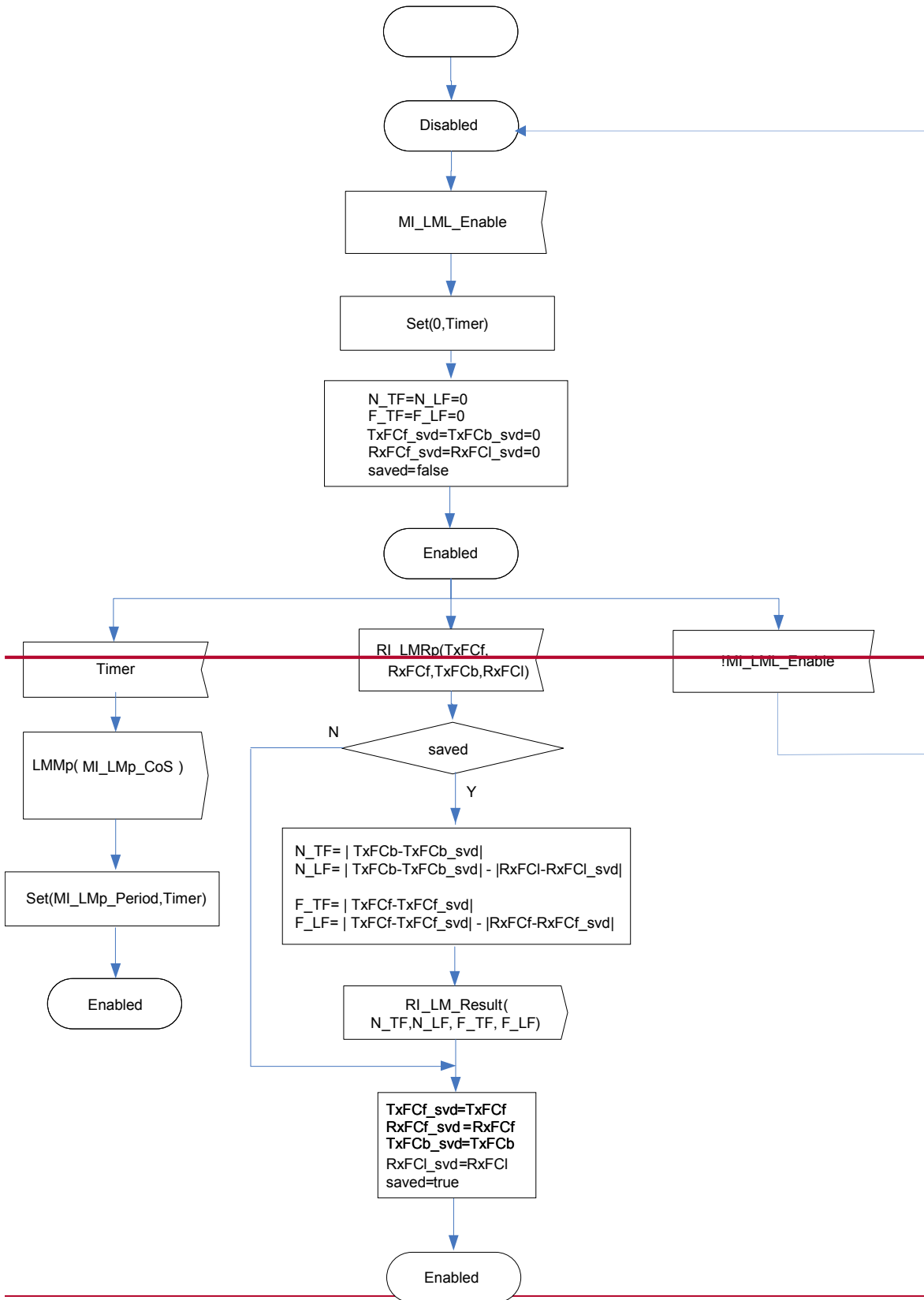

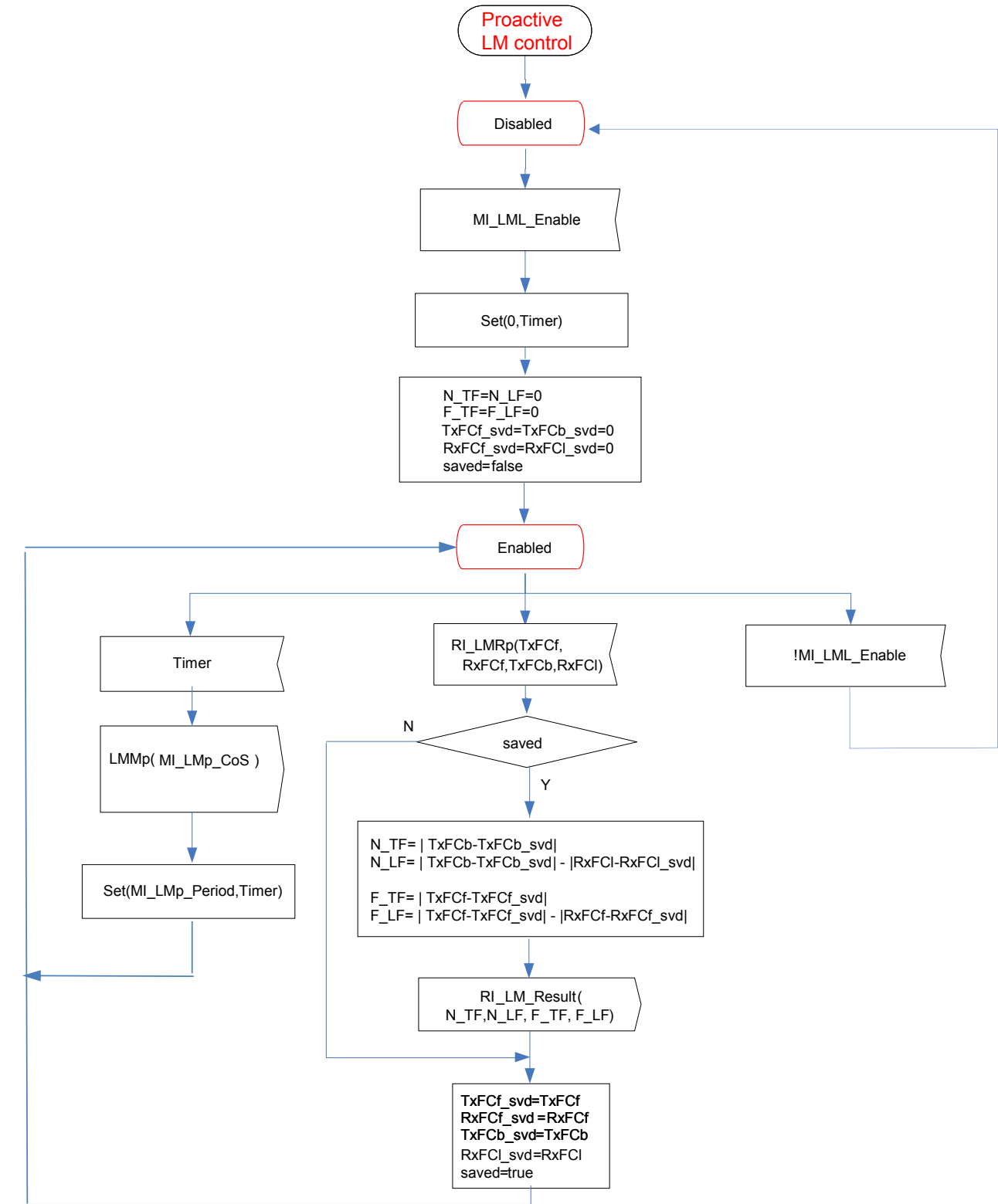

Figure 8-xx+1/G.8121.1/Y.1381.1 – Proactive LM control behaviour

8.8.4.3 Proactive LMM generation process

The behaviour of the LMMp generation process that is in LMMp Source control process is defined in Figure 8-xx+2.

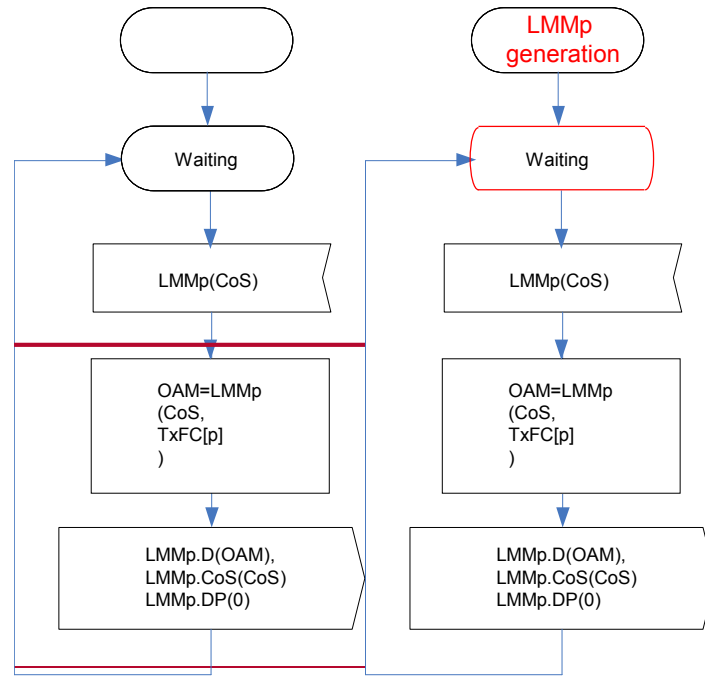

Figure 8-xx+2/ G.8121.1/Y.1381.1 – LMM generation behaviour

Upon receiving the LMM(CoS), a single LMM traffic unit is generated together with the complementing CoS and DP(0) signals.

8.8.4.4 Proactive LMM Reception Process

The proactive LMM reception process that is in proactive DMM Sink control process processes the received proactive LMM traffic units and the complementing CoS and DP signals. The behaviour is defined in Figure 8-xx+3.

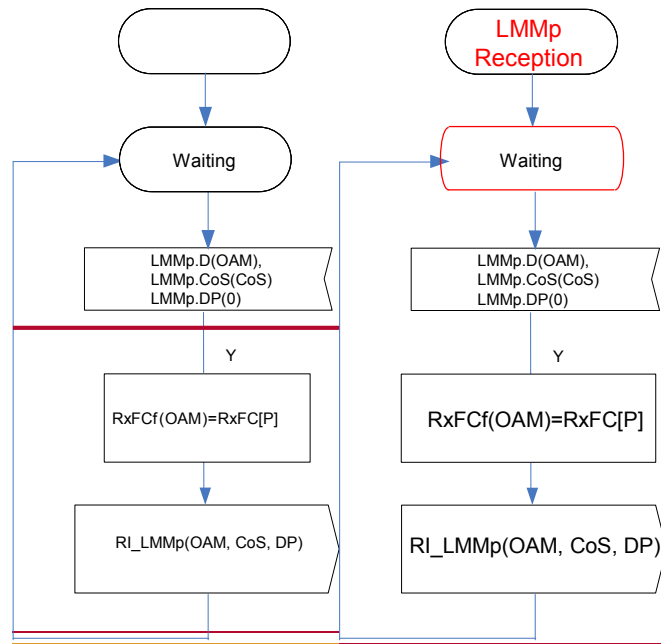

Figure 8-xx+3/ G.8121.1/Y.1381.1 – LMM reception behaviour

Traffic Unit and the complementing CoS and DP signals are forwarded as Remote Information to the LMR Generation Process.

8.8.4.5 Proactive LMR Generation Process

The Proactive LMR Generation Process that is in DMRp Source control process generates a LMRp Traffic Unit and its complementing CoS and DP signals. The behaviour is defined in Figure 8-xx+4.

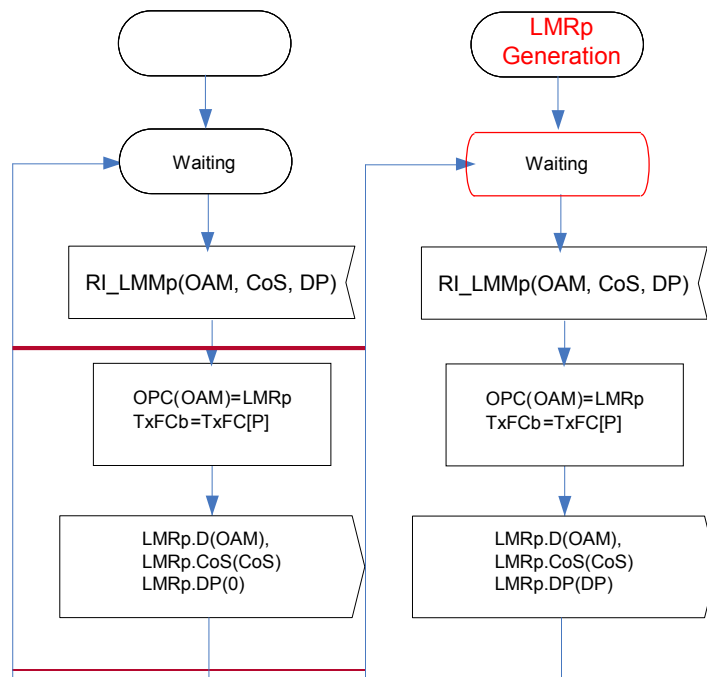

Figure 8-xx+4/ G.8121.1/Y.1381.1 – LMR generation behaviour

Upon the receipt of Remote Information containing a LMMp Traffic Unit, the LMRp generation process generates a DMR Traffic Unit and forwards it to the OAM insertion Process.

As part of the DMR generation the:

- The Opcode is changed into DMRp Opcode;
- the TxFCb field is assigned the value of the Tx counter..
- All the other fields are copied from the Remote Information containing the original DMMp Traffic Unit.

8.8.4.6 Proactive LMR Reception Process

The proactive LMR Reception Process that is in LMRp Sink control process processes the received LMRp Traffic Units and the complementing CoS and DP signals. The behaviour is defined in Figure 8-xx+5

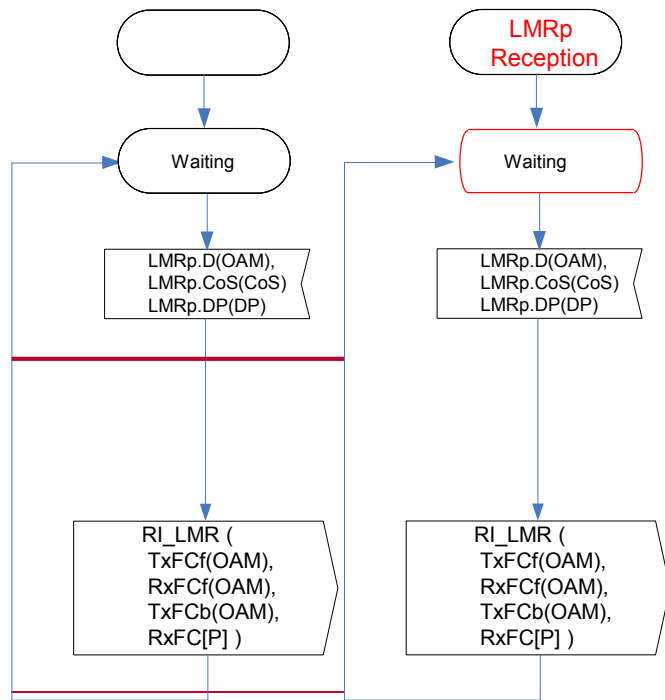

Figure 8-xx+5/ G.8121.1/Y.1381.1 – LMR generation behaviour

8.8.4.7 Counter Process for Proactive Packet Loss Measurement

For further study

This process counts the number of transmitted and received frames.

The counter process for LMM/LMR generation is defined in Figure 8-xx+6. It receives MT_AI and forwards it. It counts the number of MT_AI traffic units received with MT_AI_DP to <false (0)>.

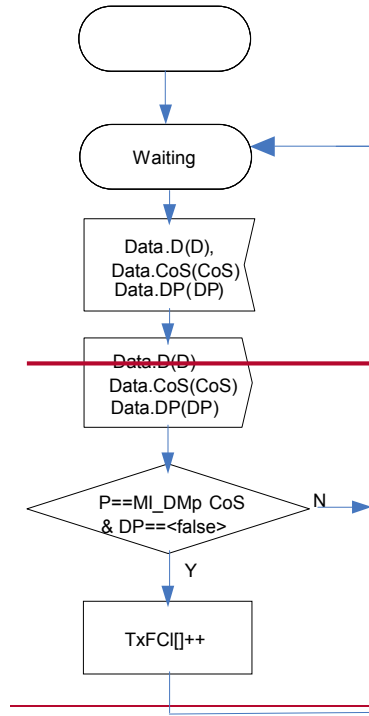

Figure 8-xx+6—Counter behaviour for LMM/LMR generation

The counter process for LMM/LMR reception is defined in Figure 8-xx+7. It receives MT_CI and forwards them as MT_AI traffic units. It counts this number of MT_AI instances with MT_AI_DP equal to <false (0)>.

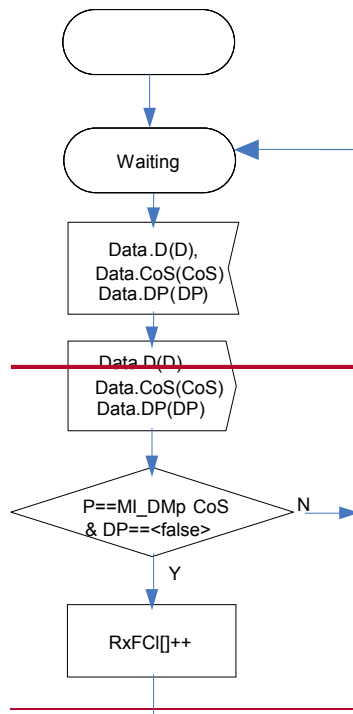

Figure 8-xx+7—Counter behaviour for LMM/LMR reception

8.8.5 On-demand Packet Loss Measurement (OAM) Process

8.8.5.1 Overview

To support this functionality, On-demand Loss Measurement (LMM/LMR) as described in [ITU-T G.8113.1] clause 8.2.6 is used.

Figure 8-16 provides the different processes inside MEPs and MIPs that are involved in the Loss Measurement Protocol.

The MEP On-Demand OAM Source insertion process is defined in clause 9.2, the MEP On-Demand OAM Sink extraction process in clause 9.2, the MIP On-Demand OAM Sink Extraction process in clause 9.4, and the MIP On-Demand OAM Source insertion process in clause 9.4. In summary, they insert and extract MT_CI OAM signals into and from the stream of MT_CI_D Traffic Units together with the complementing PHB signals going through an MEP and MIP.

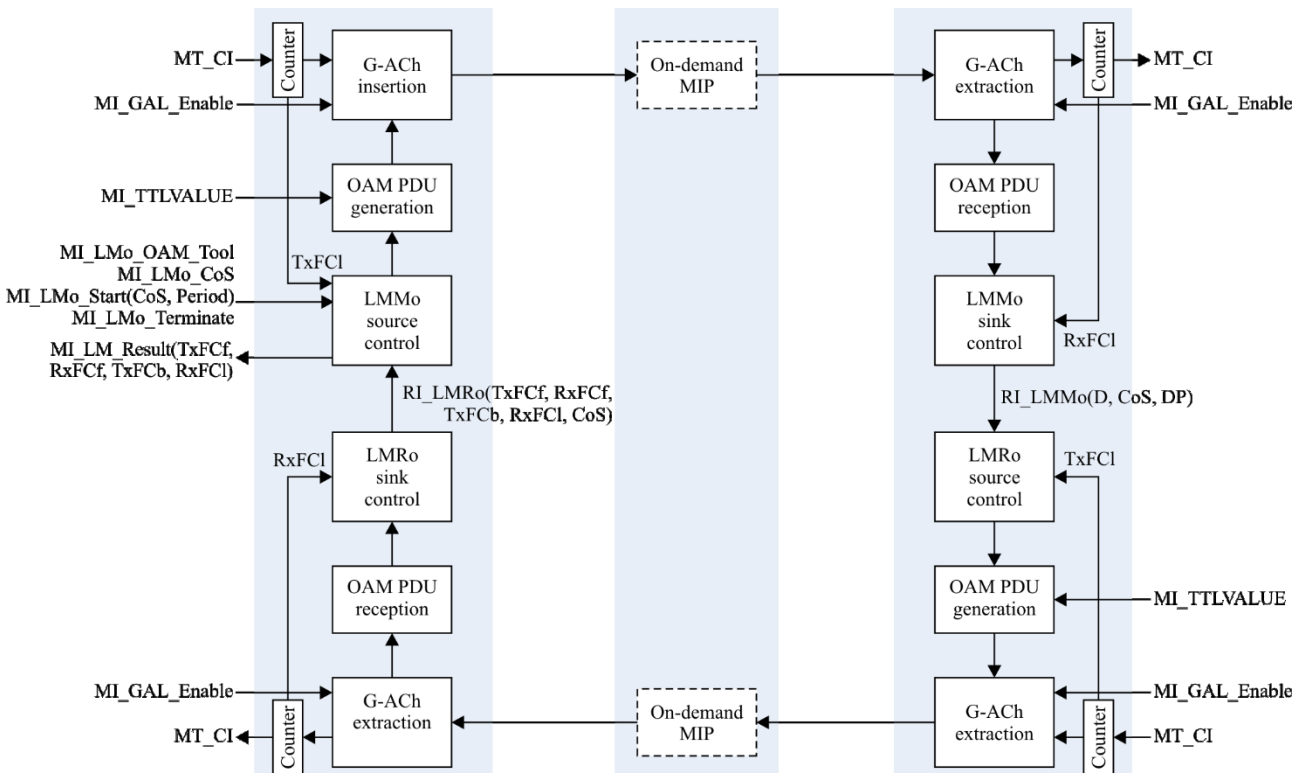
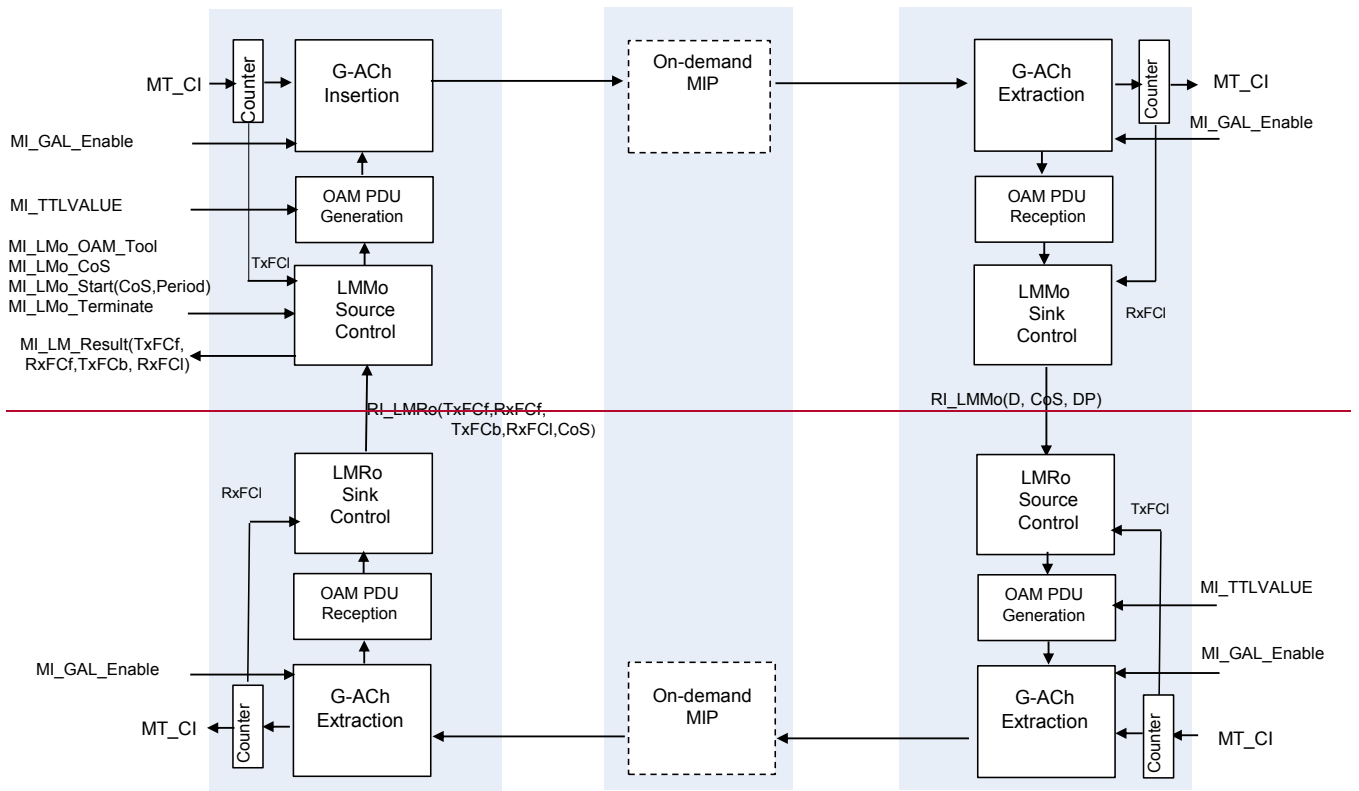

Figure 8-16 G.8121.1/Y.1381.1 – Overview of Processes involved with On-demand Loss Measurement

The LMMo source control process controls the LM protocol. The protocol is activated upon receipt of the MI_LMo_Start(CoS,Period) signal and remains activated until the MI_LMo_Terminate signal is received.

The result is communicated via the MI_LMo_Result(N_TF, N_LF, F_TF, F_LF) signal.

The LMMo Source control Protocol generates an LMM Traffic Unit that passes transparently through MIPs, but that will be processed by the LMMo Sink control Process in MEPs. The LMRo Source Process generates an LMR Traffic Unit in response to the receipt of an LMMo Traffic Unit. The LMRo Reception process receives and processes the LMRo Traffic Units.

The behaviour of the processes is defined below.

8.8.5.2 On-demand LM Source Control Process

The behaviour of the LMMo Source Control Process is defined in Figure 8-17.

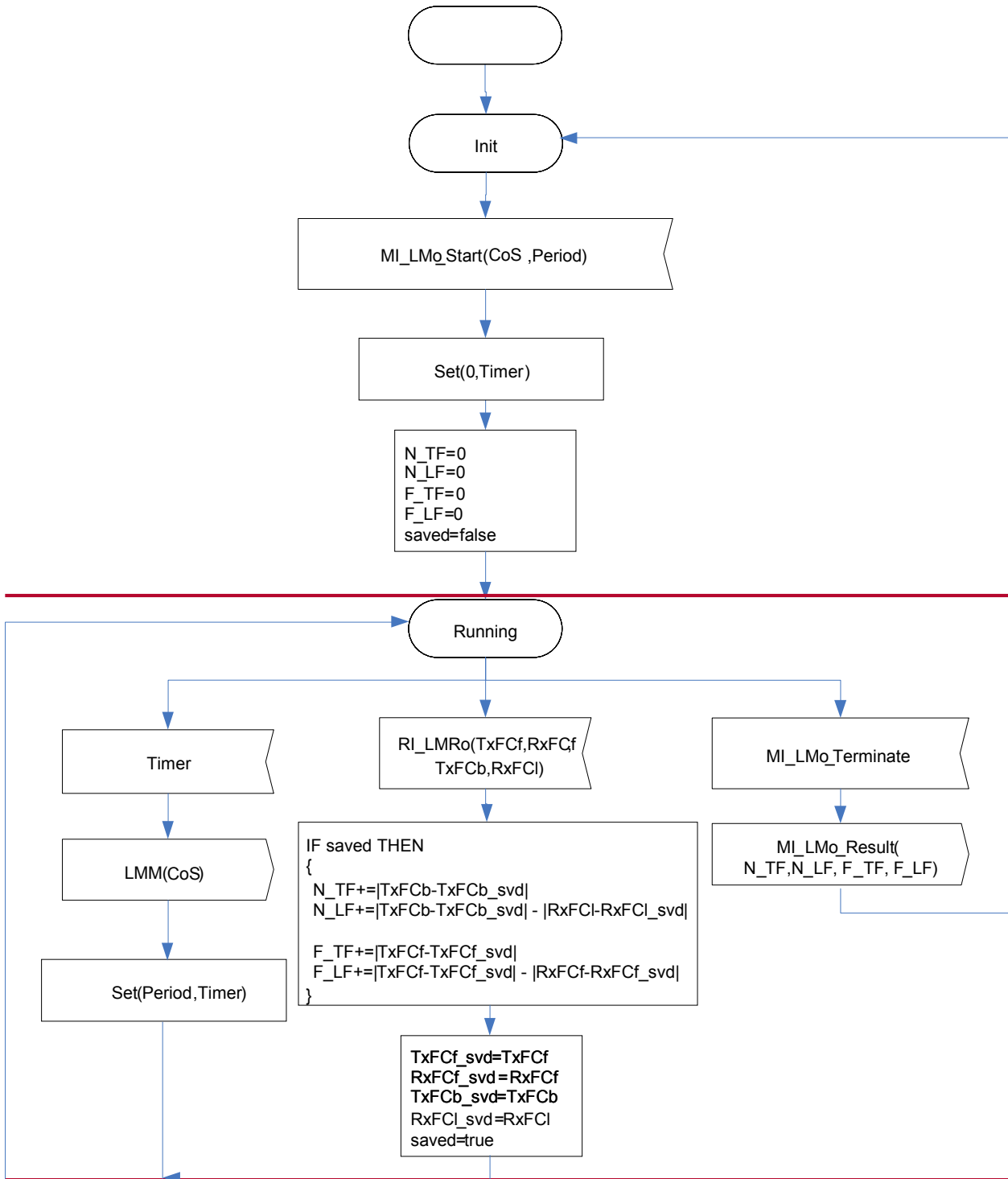

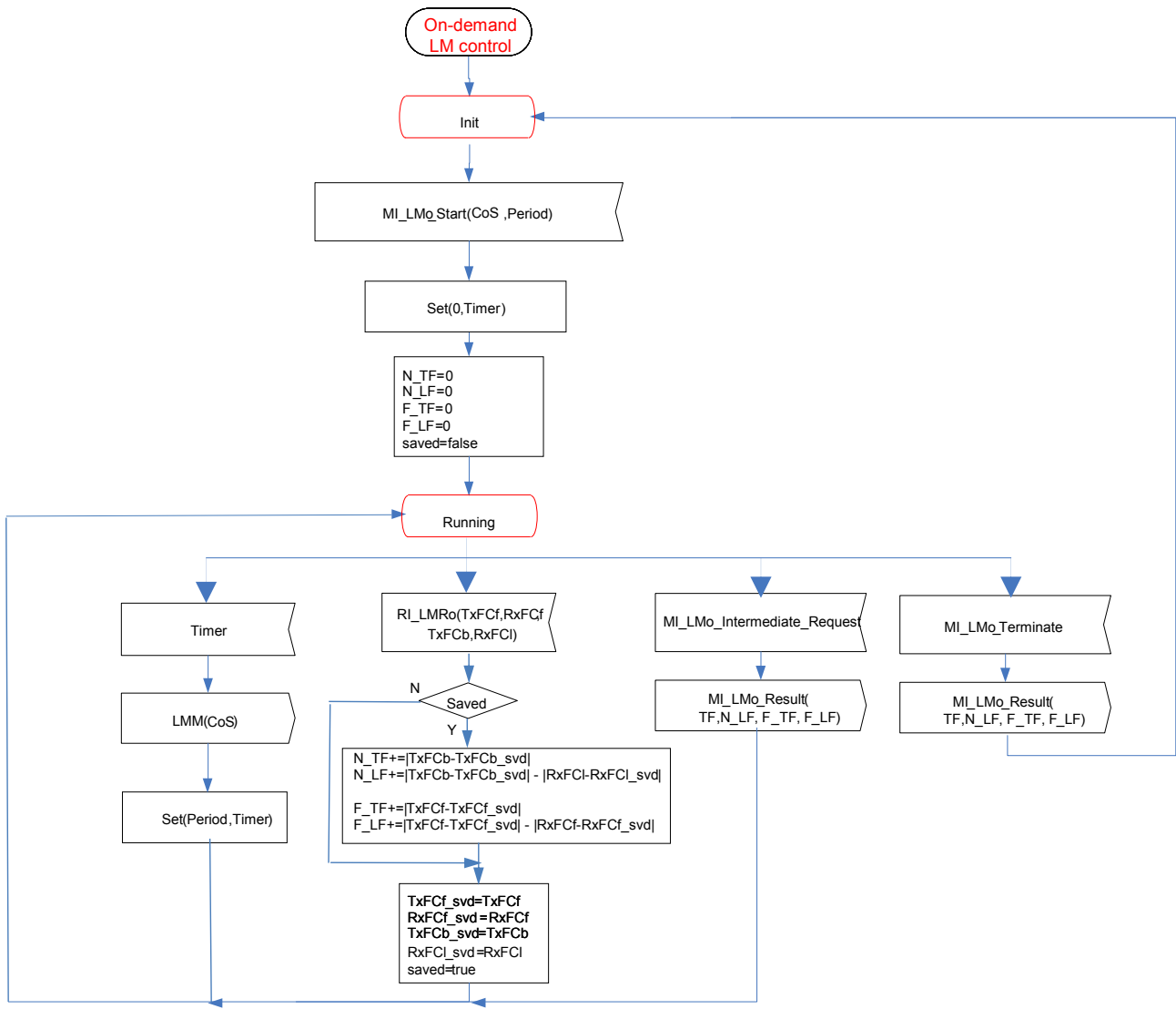

Figure 8-17/G.8121.1/Y.1381.1 – LMMo Source Control Behaviour

Upon receipt of the MI_LMo_Start(CoS,Period), the LM protocol is started. Every Period the generation of an LMM **framepacket** is triggered (using the LMMo(CoS) signal), until the MI_LMo_Terminate signal is received.

The received counters are used to count the near end and far end transmitted and lost **framepackets**. This result is reported using the MI_LMo_Result(N_TF, N_LF, F_TF, F_LF) signal after the receipt of the MI_LMo_Terminate signal.

8.8.5.3 On-demand LMM Generation Process

The behaviour of the LMMo generation process that is in LMMo Source control process is defined in Figure 8-xx+2.

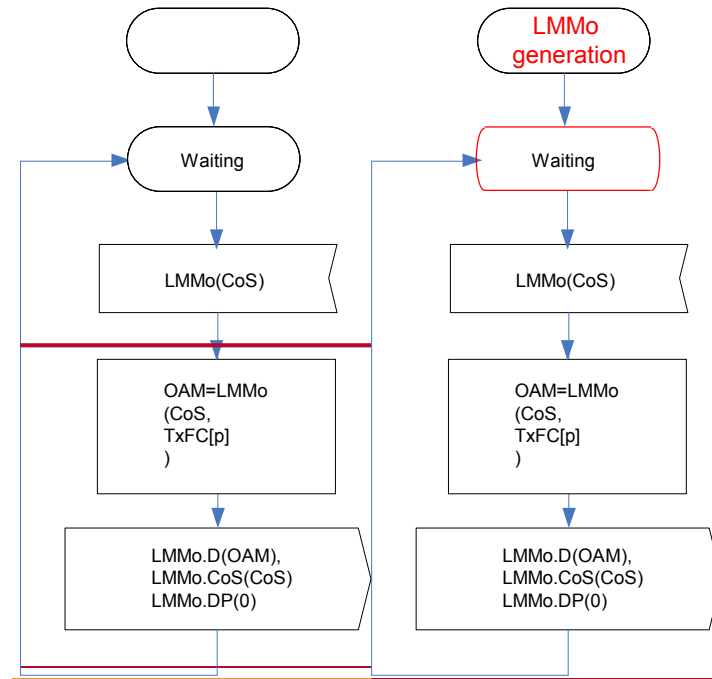

Figure 8-xxx+1/ G.8121.1/Y.1381.1 – LMM generation behaviour

Upon receiving the LMM(CoS), a single LMM traffic unit is generated together with the complementing CoS and DP(0) signals.

8.8.5.4 On-demand LMM Reception Process

The on-demand LMM reception process that is in LMMo Sink control process processes the received proactive LMM traffic units and the complementing CoS and DP signals. The behaviour is defined in Figure 8-xx+3.

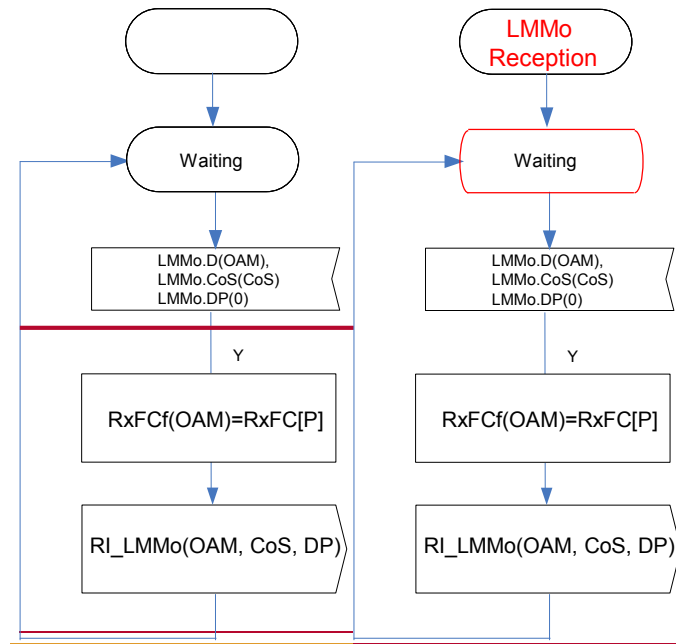

Figure 8-xxx+2/ G.8121.1/Y.1381.1 – LMM generation/reception behaviour

Traffic Unit and the complementing CoS and DP signals are forwarded as Remote Information to the LMR Generation Process.

8.8.5.5 8.8.5.5 — On-demand LMR Generation Process

The on-demand LMR Generation Process that is in DMRo Source control process generates a LMRo Traffic Unit and its complementing CoS and DP signals. The behaviour is defined in Figure 8-xx+4.

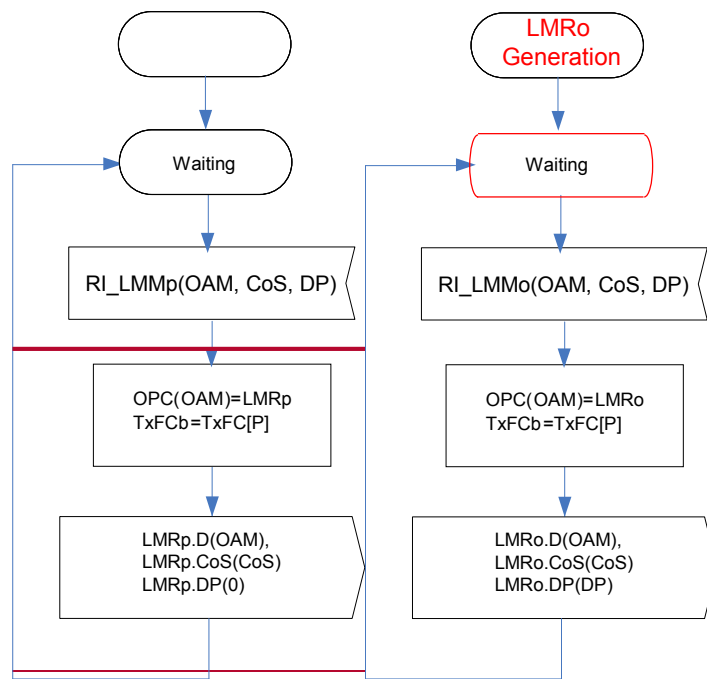

Figure 8-xxx+3/ G.8121.1/Y.1381.1 – LMR generation behaviour

Upon the receipt of Remote Information containing a LMMo Traffic Unit, the LMRo generation process generates a DMR Traffic Unit and forwards it to the OAM insertion Process.

As part of the DMR generation the:

- The Opcode is changed into DMRo Opcode;
- the TxFCb field is assigned the value of the Tx counter..
- All the other fields are copied from the Remote Information containing the original DMMo Traffic Unit.

8.8.5.6 On-demand LMR Reception Process

The on-demand LMR Reception Process that is in on-demand LMRo Sink control process processes the received LMRo Traffic Units and the complementing CoS and DP signals. The behaviour is defined in Figure 8-xx+5

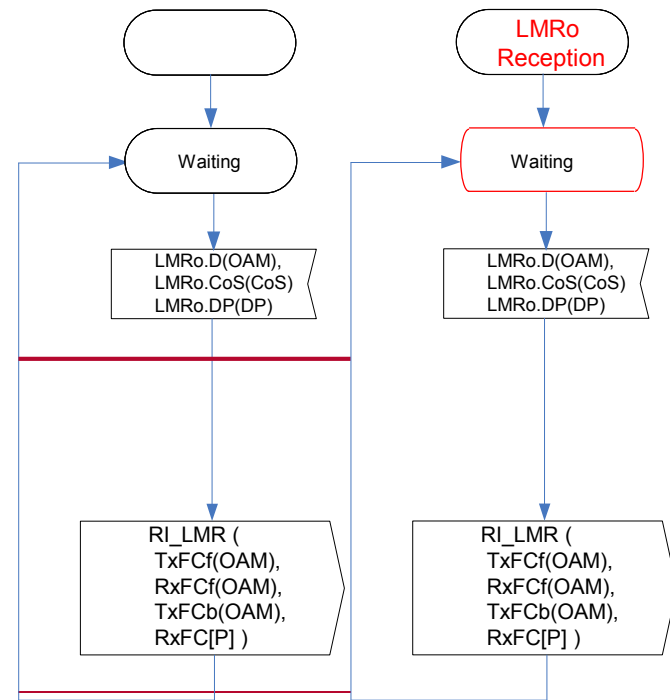

Figure 8-xxx+4/ G.8121.1/Y.1381.1 – LMR generation behaviour

8.8.5.7 Counter Process for on-demand Packet Loss Measurement

For further study.

This process counts the number of transmitted and received frames.

The counter process for LMM/LMR generation and The counter process for LMM/LMR reception are defined in Figure 8-xxx+5 and Figure 8-xxx+6

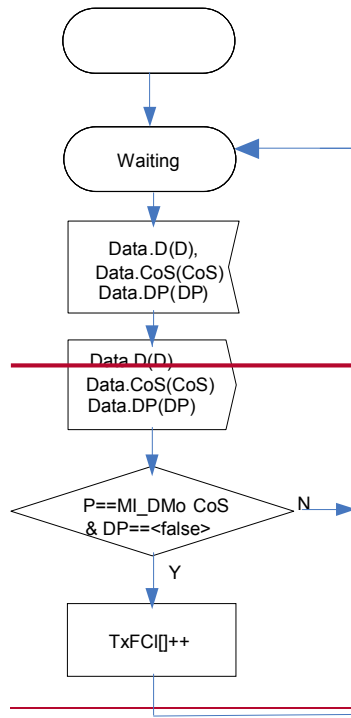

Figure 8-xx+6—Counter behaviour for LMM/LMR generation

The counter process for LMM/LMR reception receives MT_CI and forwards them as MT_AI traffic units. It counts this number of MT_AI instances with MT_AI_DP equal to <false (0)>.

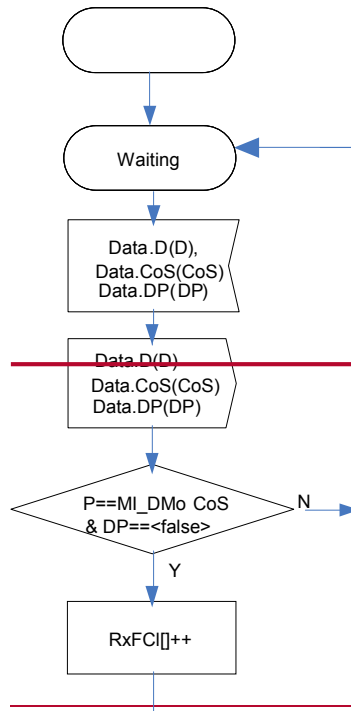

Figure 8-xx+7—Counter behaviour for LMM/LMR reception

8.8.5.3 On-demand LMx Generation Process

The LMx Generation Process contains both the LMMo Generation functionality in LMMo Source control process and LMRo Generation functionality in LMRo Source control process.

Figure 8-18 defines the behaviour of the LMx Process. The behaviour consists of three parts:

- LMMo Generation part that is triggered by the receipt of the LMMo(CoS) signal;
- LMRo Generation part that is triggered by the receipt of RI_LMMo(D,CoS,DP) signals;
- Counter part that is triggered by the receipt of a normal data signal.

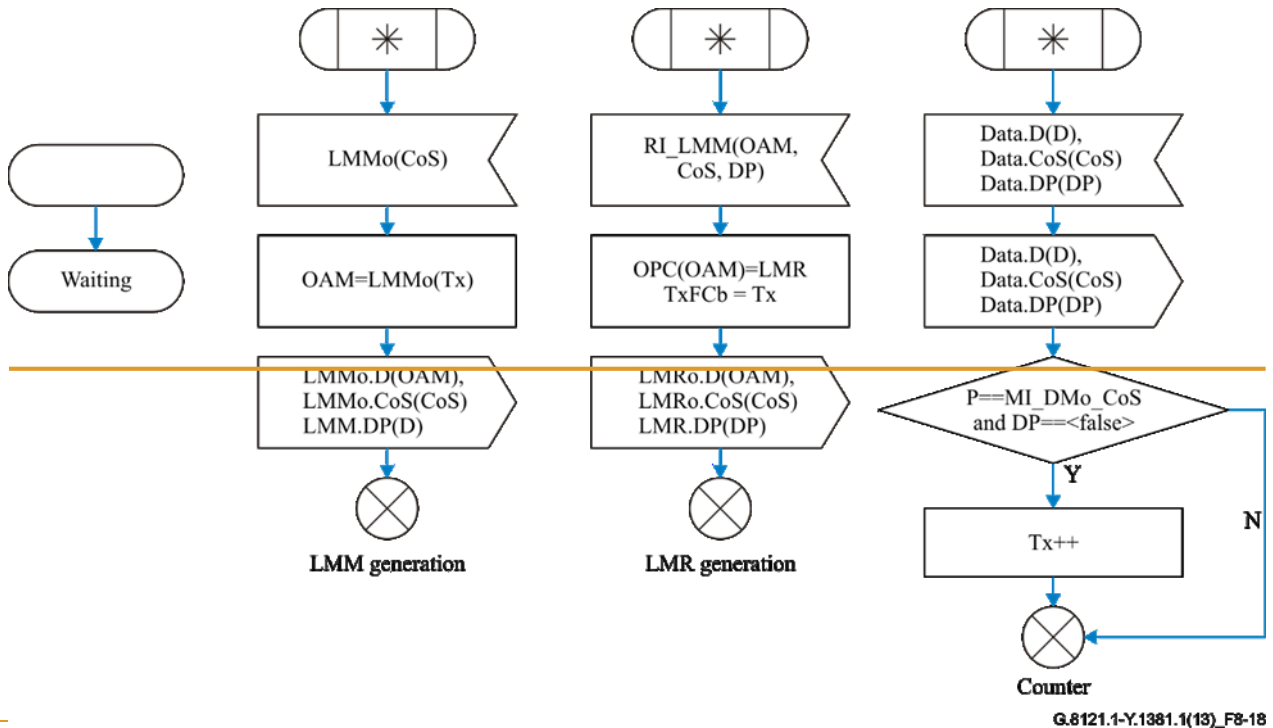

Figure 8-18/G.8121.1/Y.1381.1 On-demand LMx Generation Behaviour

Counter Part

This part receives MT_AI and forwards it. It counts the number of MT_AI traffic units received with MT_AI_P signal equal to MIo_LM_CoS and MT_AI_DP to <false (0)>.

LMMo Generation Part

This part generates an LMMo Traffic Unit on receipt of the LMMo (D, CoS, DP) signal.

8.8.5.4 On-demand LMx Reception Process

The On-demand LMx Reception Process contains both the LMMo Reception functionality in LMMo Sink control process and LMRo Reception functionality in LMRo Sink control process.

Figure 8-19 defines the behaviour of the LMx Reception Process. The behaviour consists of three parts:

- LMM Reception part that is triggered by the receipt of an LMM Traffic Unit;
- LMR Reception part that is triggered by the receipt of an LMR Traffic Unit;
- Counter part that is triggered by the receipt of a normal data signal.

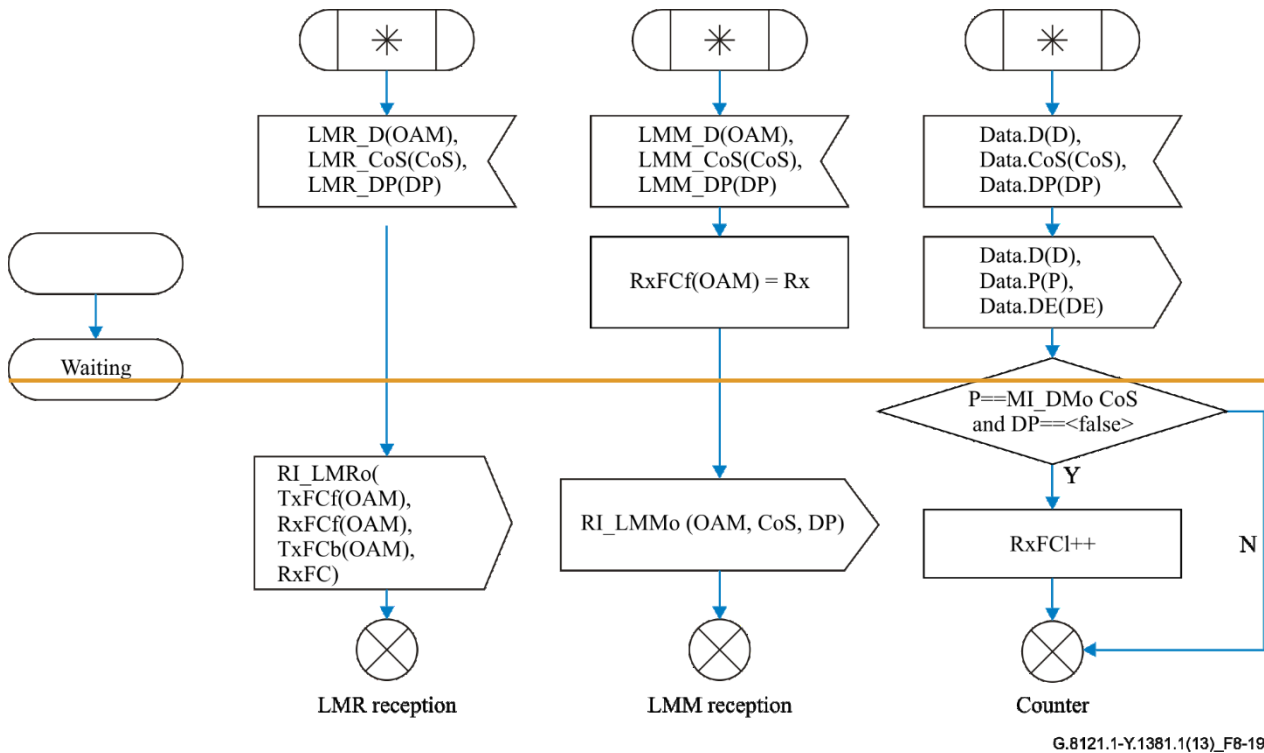

Figure 8-19/G.8121.1/Y.1381.1—On-demand LMx Reception Behaviour

Counter Part

This part receives MT_CI, extracts on-demand MT OAM framepackets and forwards the remainder as MT_AI traffic units. It counts this number of MT_AI instances with MT_AI_P signal equal to MI_LM_CoS and MT_AI_DE equal to <false (0)>.

LMMo Reception Part

This part processes received LMM Traffic Units. If this is the case the LMM Reception process writes the Rx Counter value to the received Traffic Unit in the RxFCf field, and forwards the received Traffic Unit and complementing CoS and DP signals as Remote Information to the LMR Generation Process.

LMRo Reception Part

This part process received LMR Traffic Units. It extracts the counter values TxFCf, RxFCf, TxFCb from the received Traffic Unit. These values together with the value of the Rx counter (RxFCI) are forwarded as RI signals.

8.8.6 Proactive Packet Delay Measurement (DMp)

~~This functionality is not defined in [ITU-T G.8113.1].~~

8.8.6.1 Overview

To support this functionality, proactive Delay Measurement as described in [ITU-T G.8113.1] clause 8.2.8 for single-ended Delay Measurement and [ITU-T G.8113.1] clause 8.2.7 for dual-ended Delay Measurement is used.

Figure 8-yy provides the different processes inside MEPs and MIPs that are involved in the single-ended Delay Measurement Protocol.

The MEP proactive OAM insertion process is defined in clause 9.2.1.1, the MEP OAM proactive extraction process in clause 9.2.1.2. In summary, they insert and extract MT_CI OAM signals into and from the stream of MT_CI D traffic units and the complementing CoS and D signals going through an MEP and MIP; the extraction is based on OAM_Tool.

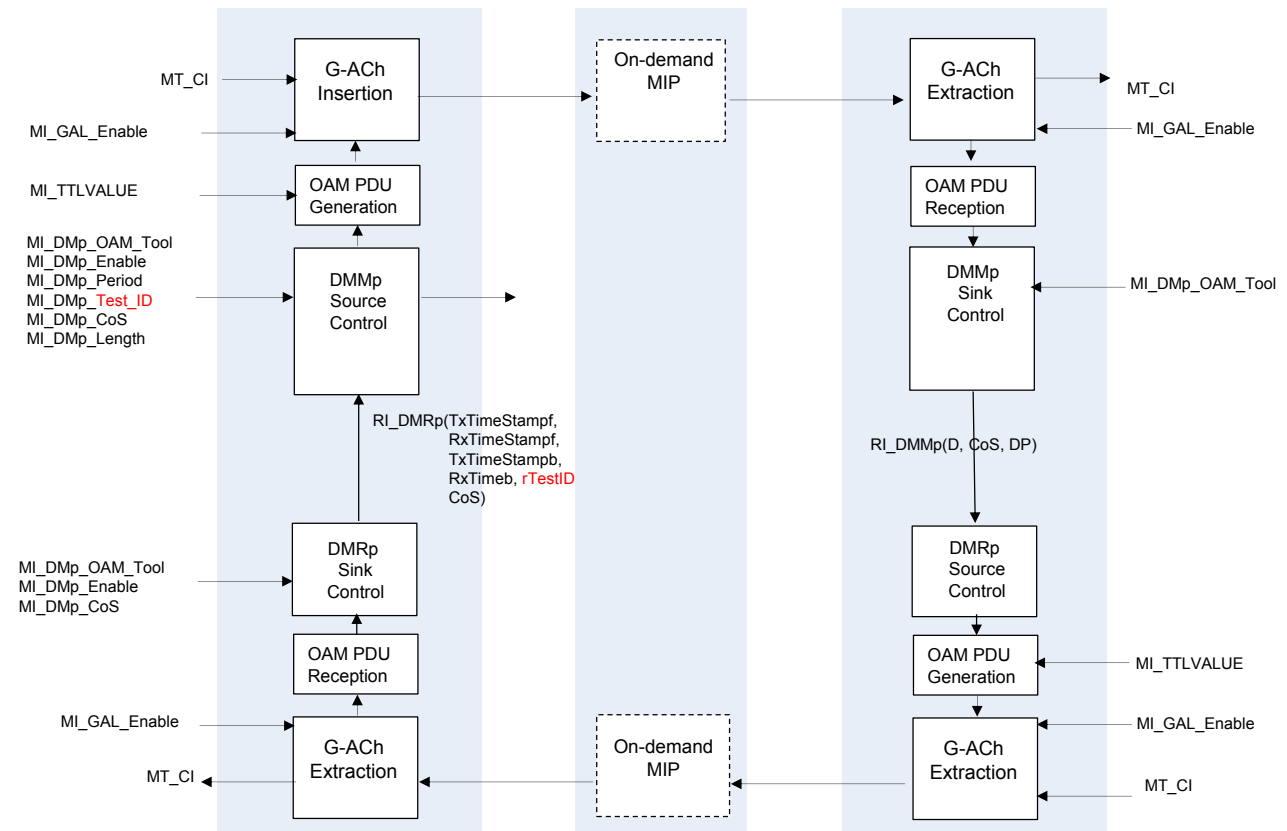

Figure 8-vv – Overview of processes involved with proactive single-ended delay measurement

The proactive DM control process controls the proactive DM protocol. If MI_DMp_Enable is set the DMM framepackets are sent periodically. The DMM framepackets are generated with a periodicity determined by MI_DMp_Period and with a priority determined by MI_DMp_CoS. The result (B_FD, F_FD, N_FD) is reported via a DMRp Sink Control process. If the proactive DM control process activates the multiple monitoring on different CoS levels simultaneously, each result is independently managed per CoS level. Optional test ID TLVs can be utilized to distinguish each measurement if multiple measurements are simultaneously activated in an ME.

[Contributor's note: test ID TLV is not considered in G.8113.1]

Figure 8-zz provides the different processes inside MEPs and MIPs that are involved with proactive dual-ended delay measurement

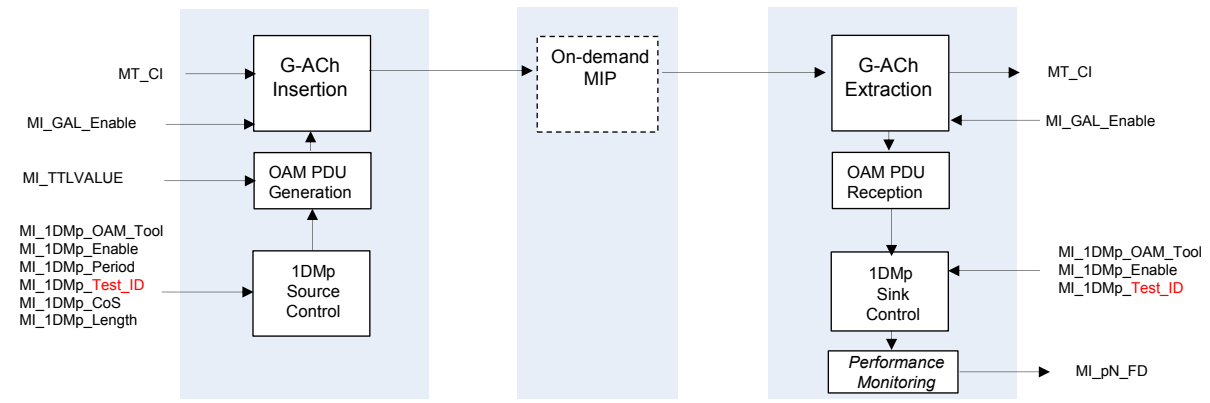

Figure 8-yy+1 – Overview of processes involved with proactive dual-ended delay measurement

The MEP proactive-OAM source insertion process is defined in clause 9.2.1.1, the MEP proactive OAM sink extraction process in clause 9.2.1.2, and the MIP on-demand OAM sink extraction process in clause 9.4.2.2.

The 1DMp Source Control process triggers the generation of 1DMp traffic units if MI_1DMp_Enable signal is set. The 1DMp ~~frame~~packets are generated with a periodicity determined by MI_1DMp_Period and with a priority determined by MI_1DMp_CoS. The result (N_FD) is reported via 1DMp Sink Control process.

8.8.6.2 Proactive DM Source Control Process

The behaviour of the proactive DM control process is defined in Figure 8-yy+2. If the MI_DMp_Enable is asserted, the process starts to generate DMM ~~frame~~packets (using the DMM(MI_DM_CoS,1, Test ID TLV,TLV) signal). The result (B_FD, F_FD, N_FD) is reported via a DMR reception.

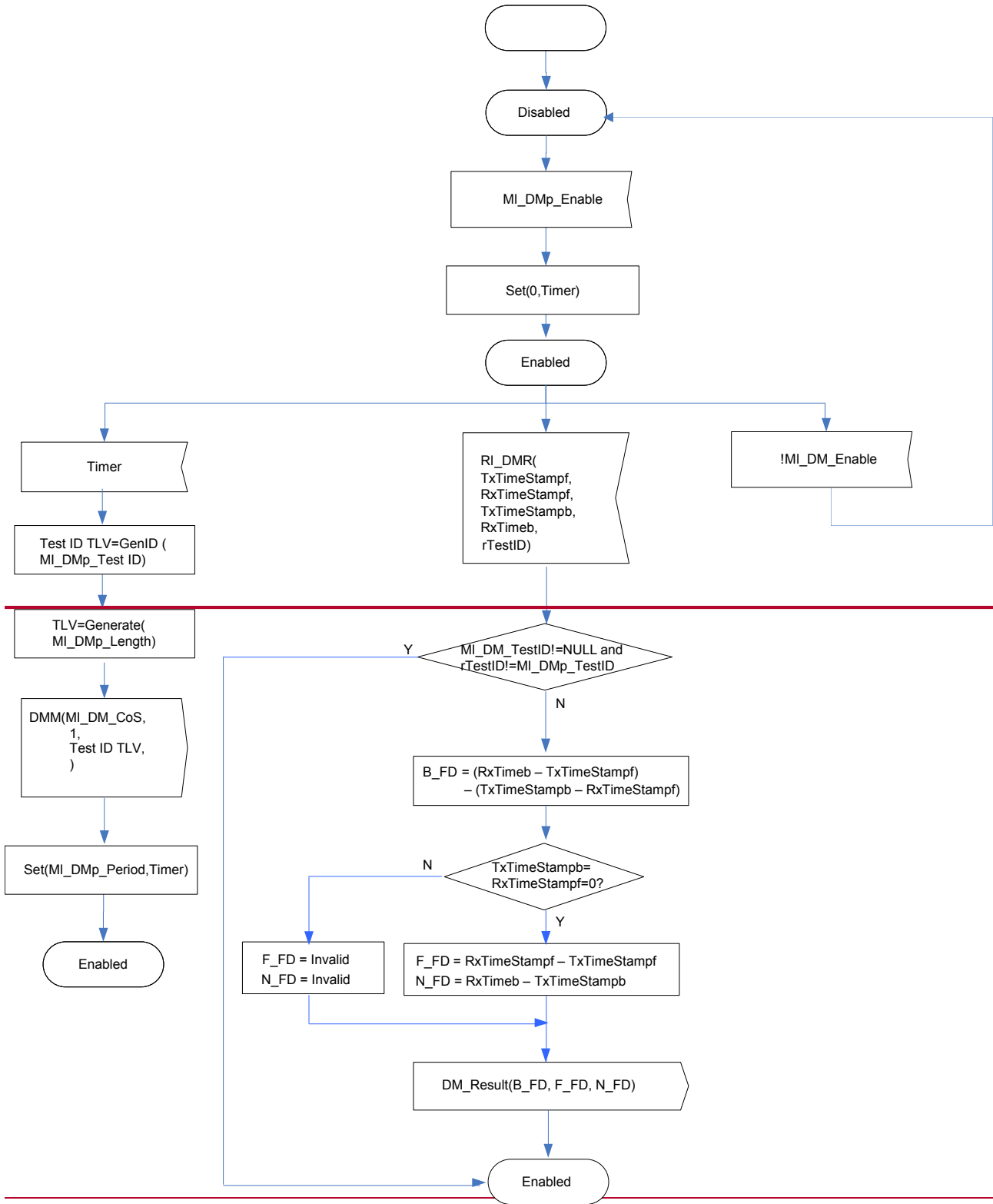

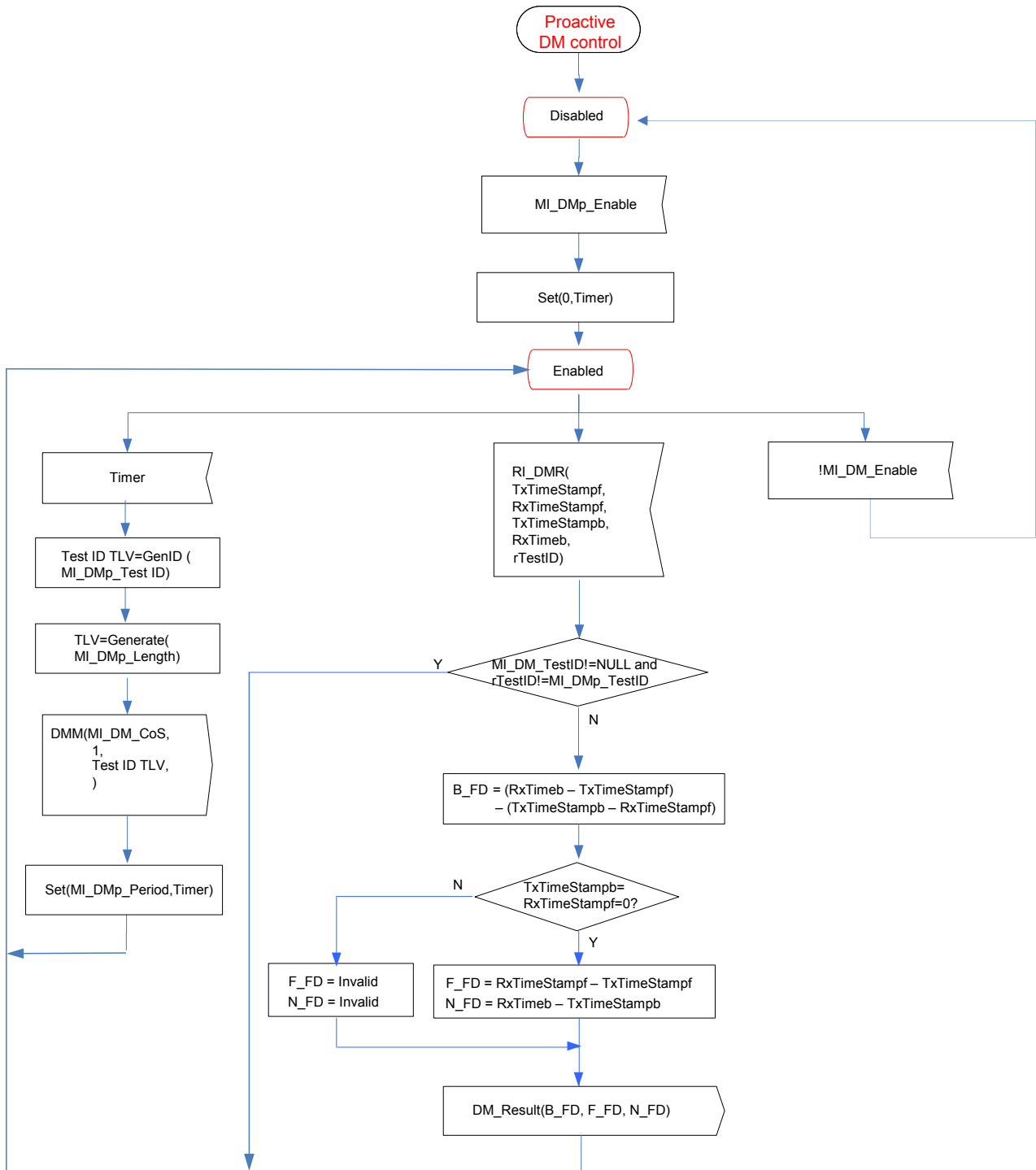

Figure 8-yy+2 – Proactive DM control behaviour

8.8.6.3 Proactive DMM Generation Process

The behaviour of the DMMp generation process that is in DMM Source control process is defined in Figure 8-yy+3.

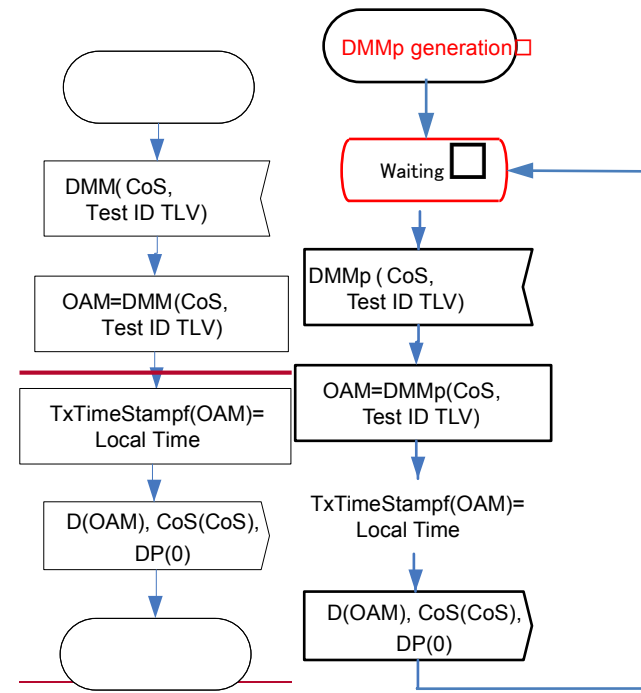

Figure 8-vv+3 – DMM generation behaviour

Upon receiving the DMM(CoS, Test ID TLV), a single DMM traffic unit is generated together with the complementing CoS and DP signals. The TxTimeStampf field is assigned the value of the local time.

The CoS signal value is defined by DMM(CoS). The DP signal is set to 0. The test ID signal is determined by the DMM(Test ID TLV) signal.

8.8.6.4 Proactive DMM Reception Process

The proactive DMM reception process that is in proactive DMM Sink control process processes the received proactive DMM traffic units and the complementing CoS and DP signals. The behaviour is defined in Figure 8-yy+4.

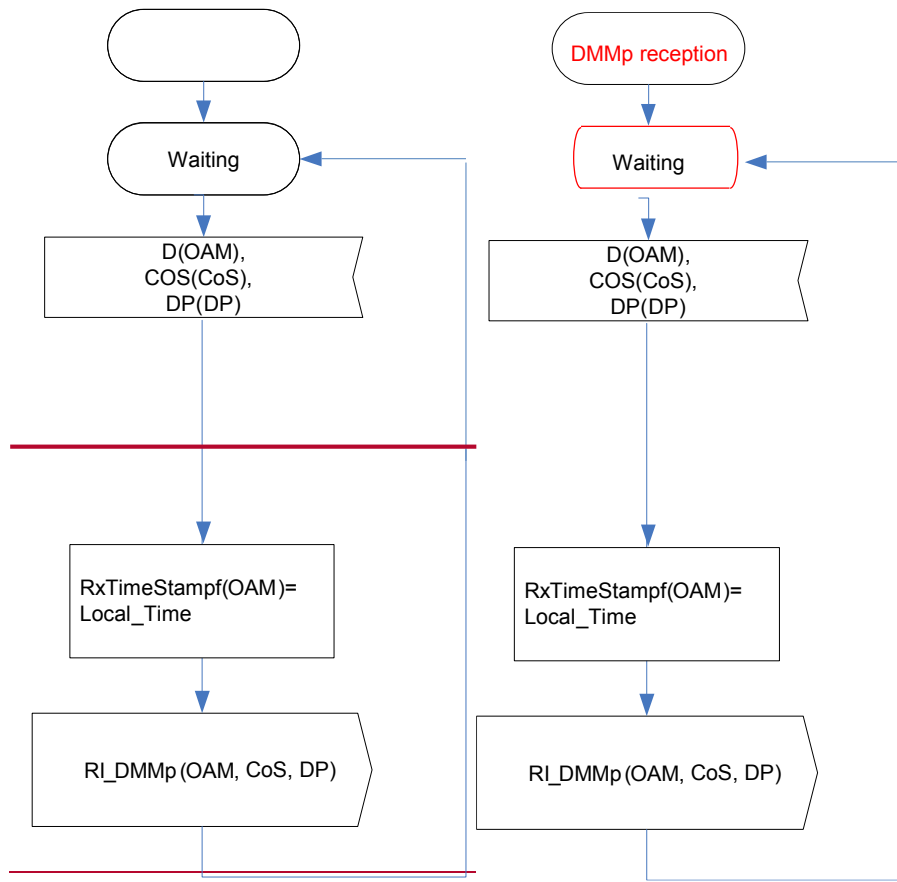

Figure 8-yy+4 – DMM reception behaviour

Traffic Unit and the complementing CoS and DP signals are forwarded as Remote Information to the DMR Generation Process.

8.8.6.5 Proactive DMR Generation Process

The Proactive DMR Generation Process that is in DMR Source control process generates a DMRp Traffic Unit and its complementing CoS and DP signals. The behaviour is defined in Figure 8-yy+5.

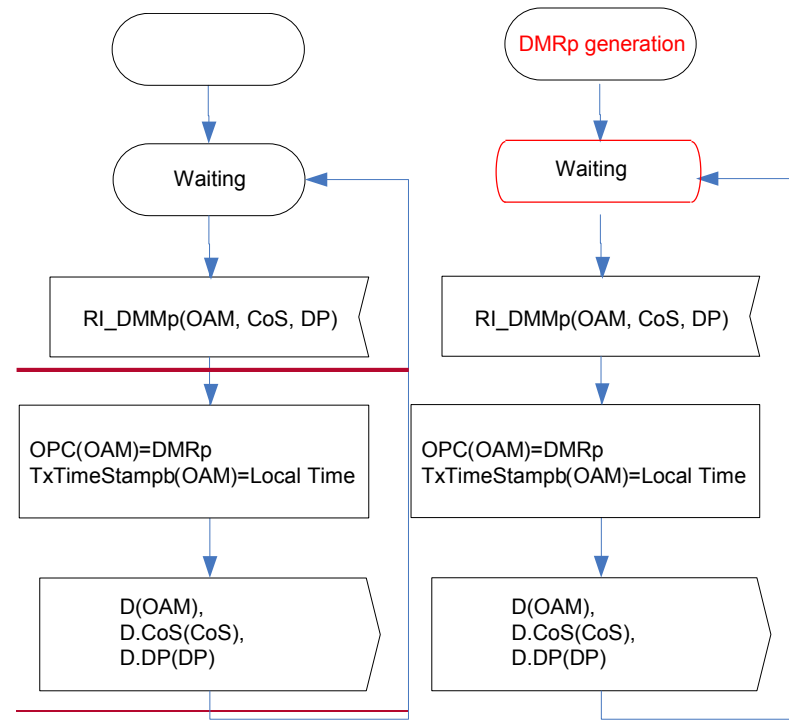

Figure 8-yy+5/G.8121.1/Y.1381.1 – Proactive DMR Generation Behaviour

Upon the receipt of Remote Information containing a DMMp Traffic Unit, the DMR generation process generates a DMR Traffic Unit and forwards it to the OAM insertion Process.

As part of the DMR generation the:

- The Opcode is changed into DMRp Opcode;
- The TxTimeStampb field is assigned the value of the Local Time.
- All the other fields (including TLVs and padding after the End TLV) are copied from the Remote Information containing the original DMM Traffic Unit.

The TLVs are copied from the Remote Information containing the original DMM Traffic Unit. If multiple TLVs exist, the order of the TLVs is unchanged.

8.8.6.6 Proactive DMR Reception Process

The proactive DMR Reception Process that is in DMRp Sink control process processes the received DMRp Traffic Units and the complementing CoS and DP signals. The behaviour is defined in Figure 8-yy+6

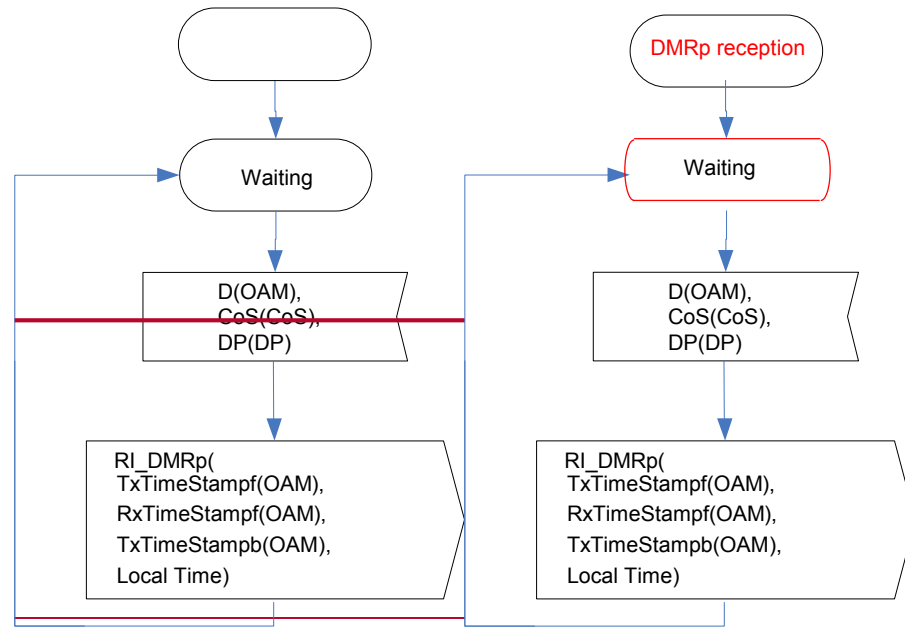

Figure 8-yy+6/G.8121.1/Y.1381.1 – DMR Reception Behaviour

If the DMR Traffic Unit is processed, the TxTimeStampf, RxTimeStampf, TxTimeStamptb and Test ID are extracted from the Traffic Unit and signalled together with the Local Time.

8.8.6.7 Proactive 1DM Source Control Process

The behaviour of the proactive 1DM control process is defined in Figure 8-yy+7.

If the MI_1DMp_Enable is asserted, the process starts to generate 1DMp ~~frame~~packets (using the 1DMp(MI_1DMp_CoS, Test ID TLV) signal.

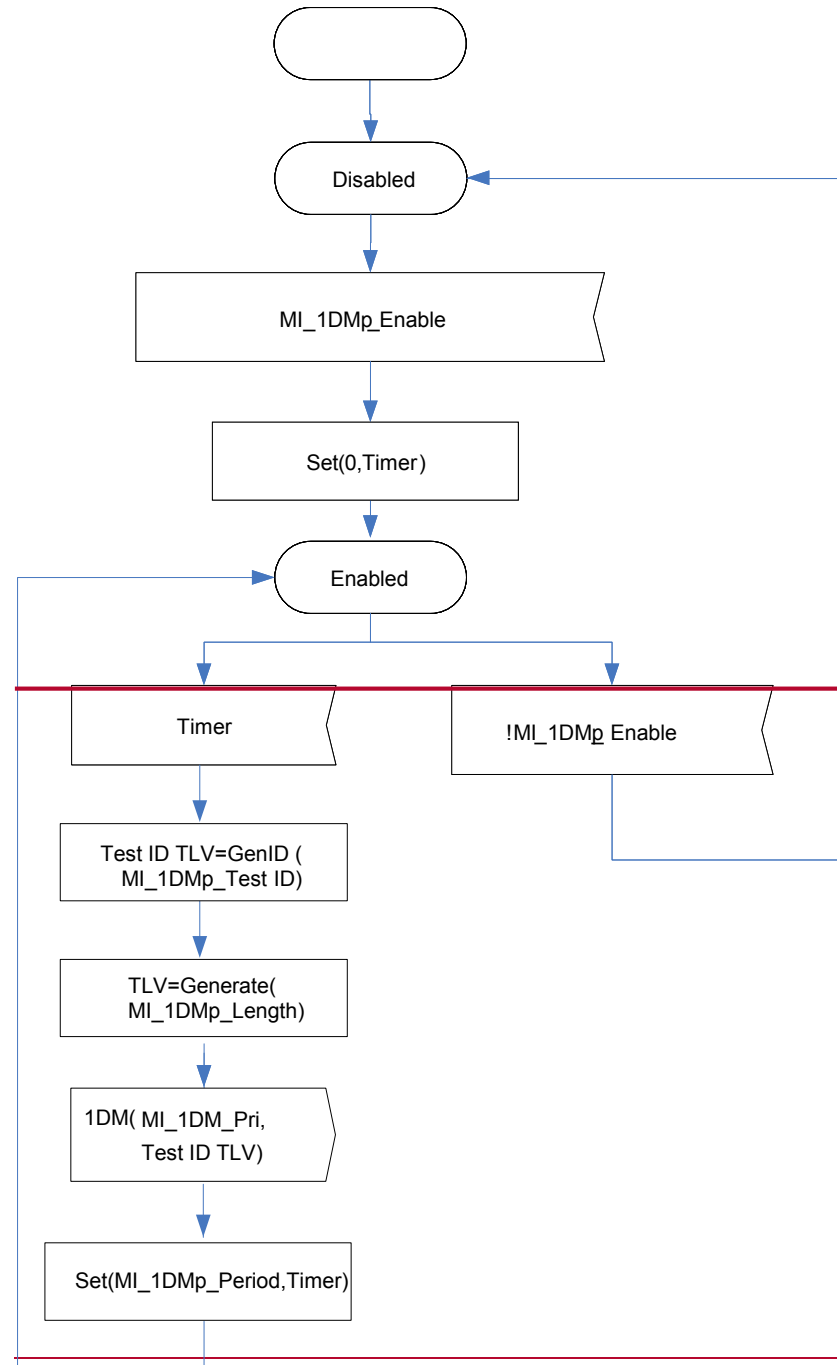

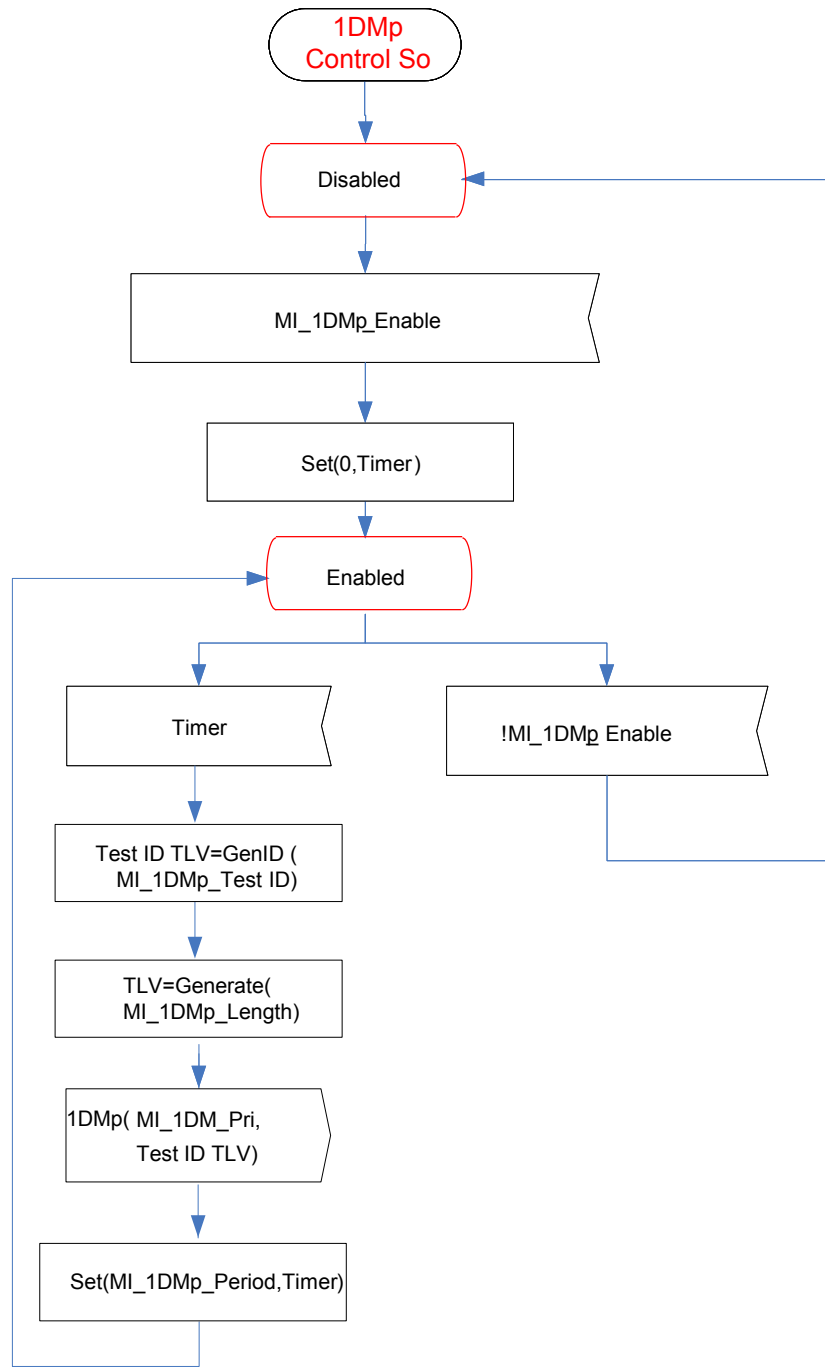

Figure 8-yy+7 – Proactive 1DM Control So behaviour

The behaviour of the proactive 1DM control process is defined in Figure 8-60.

If the MI_1DM_Enable is asserted, the process starts to generate 1DM ~~frame~~packets signal.

8.8.6.8 Proactive 1DM Generation Process

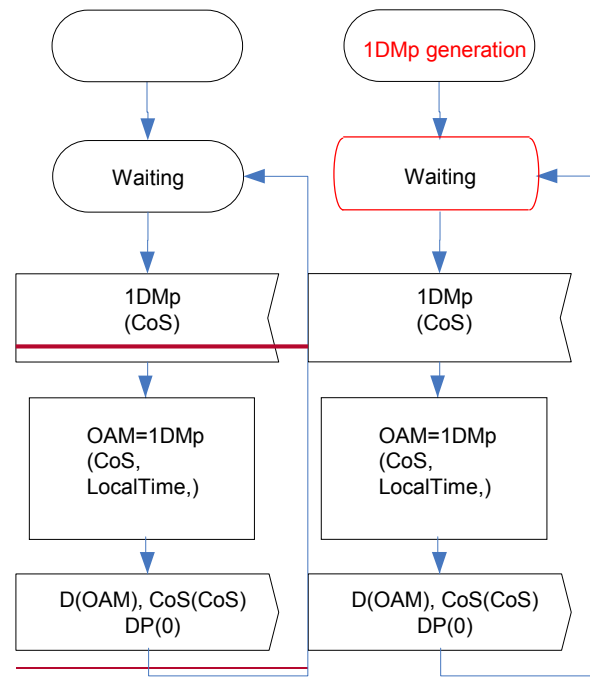

Figure 8-vv+8/G.8121.1/Y.1381.1 – 1DM Generation Behaviour

Figure 8-yy+8 shows the proactive 1DM Generation Process in 1DM Source control process. Upon receiving the 1DMp(CoS) signal a single 1DM Traffic Unit is generated by the OAM=1DM (CoS, LocalTime,) call.

Together with this 1DMp Traffic Unit the complementing CoS and DP signals are generated. The TxTimeStampf field is assigned the value of the Local Time. The value of the CoS signal is determined by the 1DMp(CoS) signal. The DP signal is set to 0.

8.8.6.9 Proactive 1DM Reception Process

The proactive 1DM Reception Process in 1DM Sink control process processes the received 1DMp Traffic Units and the complementing P and CoS signals. The behaviour is defined in Figure 8-yy+9.

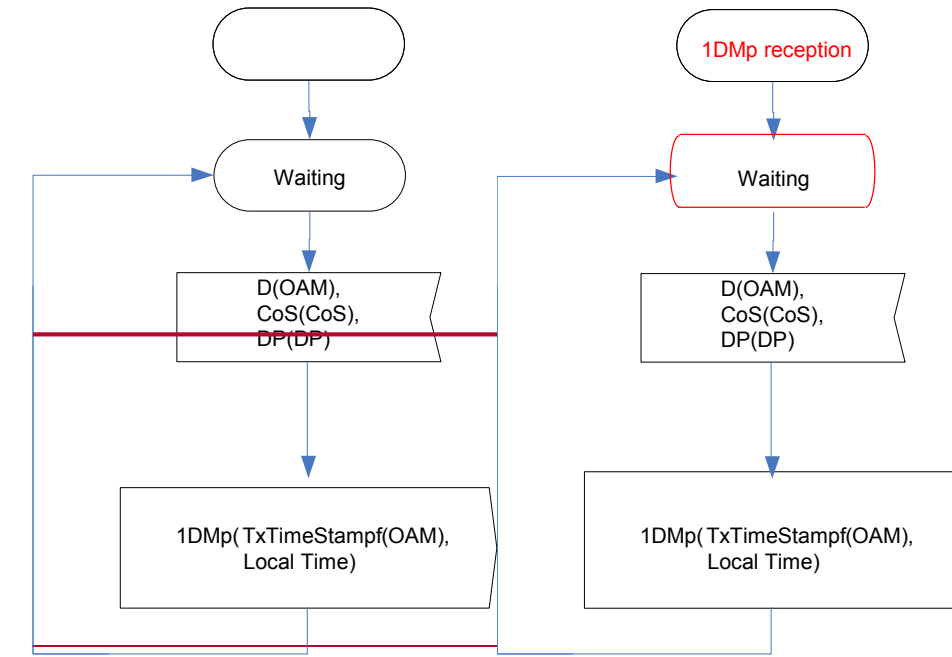
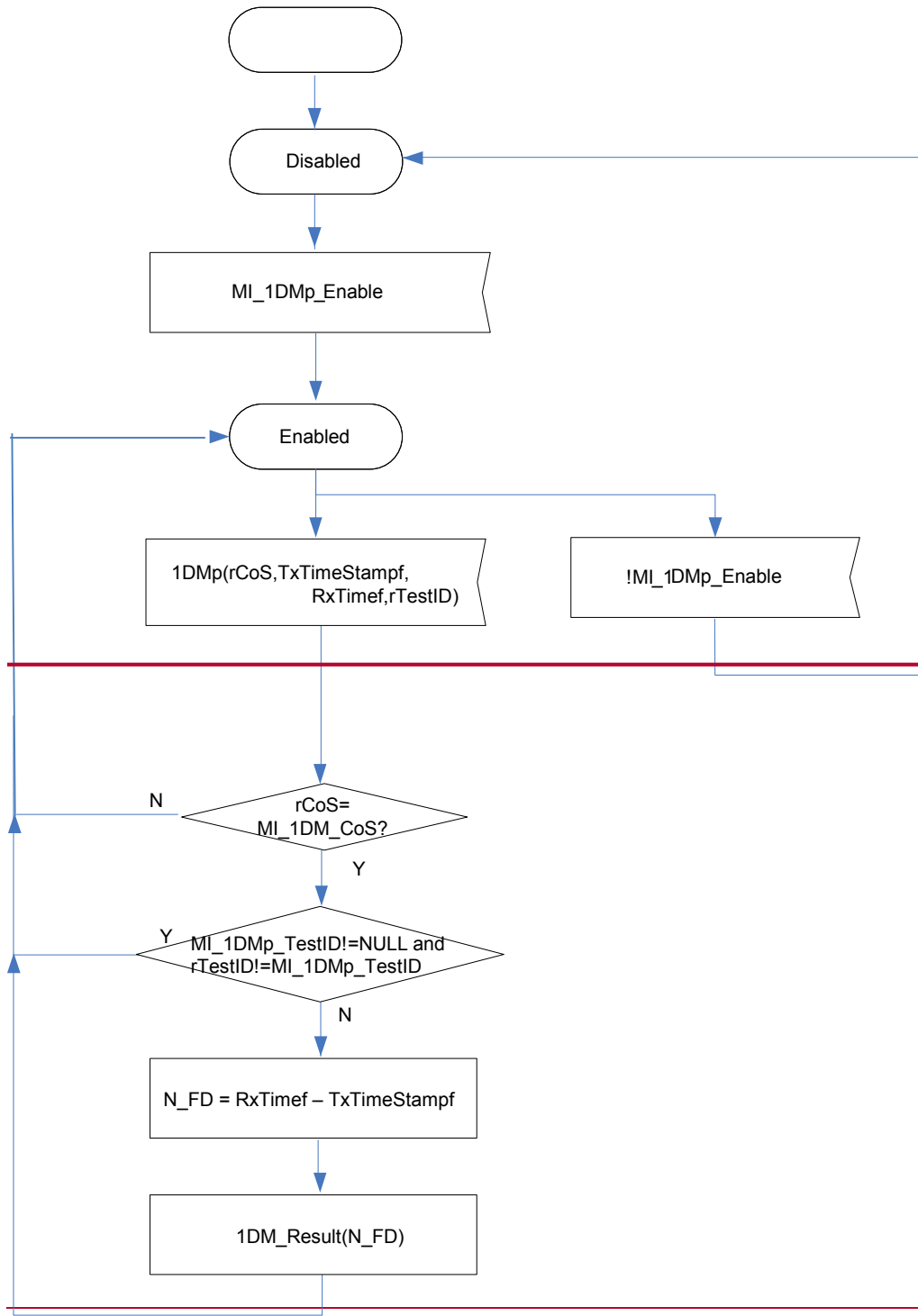

Figure 8-yy+9/G.8121.1/Y.1381.1 – 1DM Reception Behaviour

If the 1DMp Traffic Unit is processed and TxTimeStampf fields are extracted and forwarded to the 1DMp Control_Sk process together with the Local Time using the 1DMp (TxTimeStampf, RxTimef) signal.

8.8.6.10 Proactive 1DM Sink Control Sk Process

The behaviour of the proactive 1DMp Control Sink Process is defined in Figure 8-yy+10. If the MI_1DMp_Enable is asserted, the result (N_FD) is reported via a 1DMp reception.



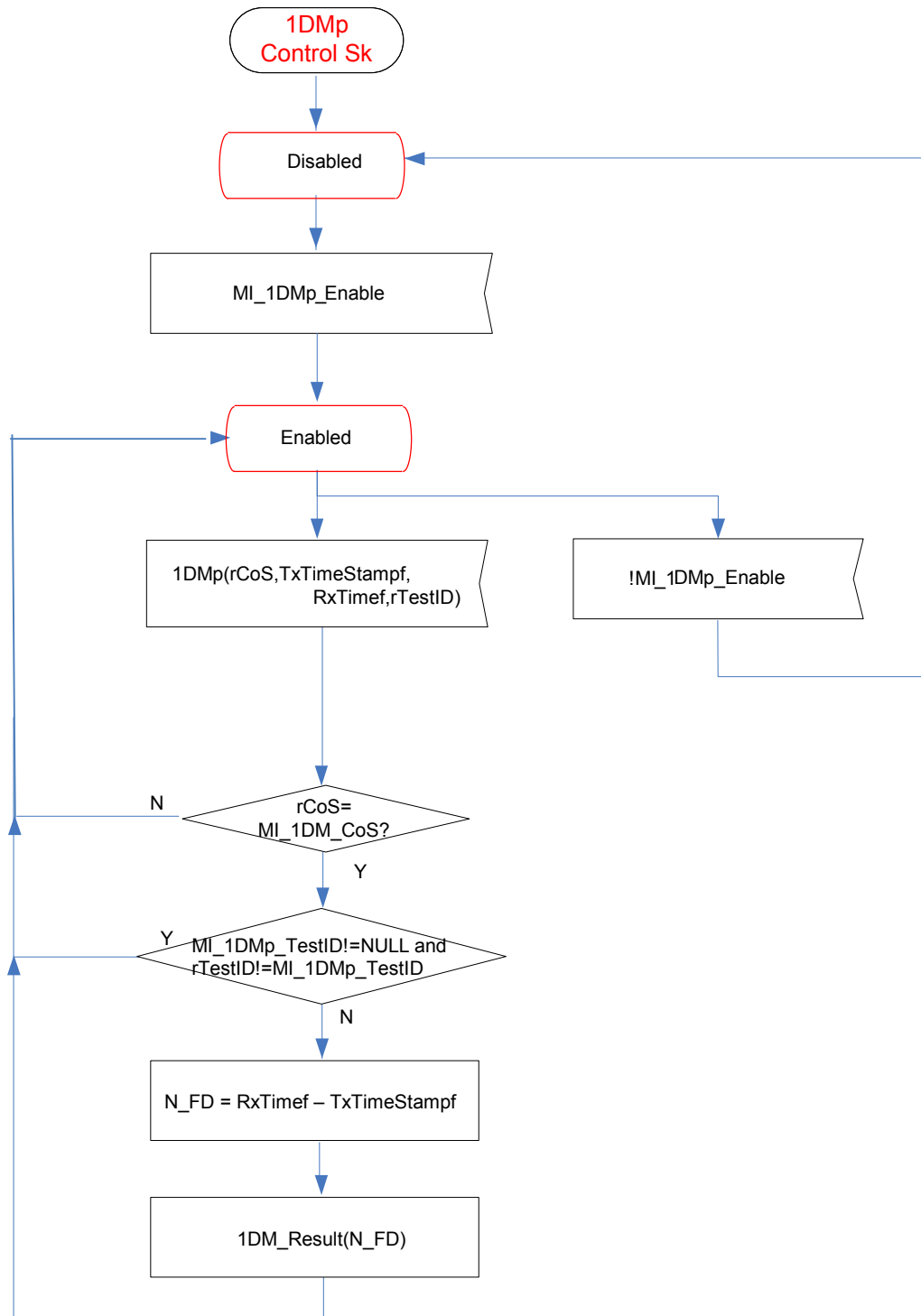

Figure 8-yy+10/G.8121.1/Y.1381.1 – Proactive 1DM Control Sink Process

Overview

To support this functionality, proactive Delay Measurement (DMM/DMR) as described in [ITU-T G.8113.1] clause 8.2.7 for one-way and [ITU-T G.8113.1] clause 8.2.8 for two-way is used.

Figure 8-yy provides the different processes inside MEPs and MIPs that are involved in the two-way Delay Measurement Protocol.

...

Figure 8-~~zz~~ provides the different processes inside MEPs and MIPs that are involved in the ~~One Way Delay Measurement Protocol~~

~~...~~

~~Proactive DM Source Control Process~~

~~Proactive DMM Generation Process~~

~~Proactive DMM Reception Process~~

~~Proactive DMR Generation Process~~

~~Proactive DMR Reception Process~~

~~Proactive 1DM Source Control Process~~

~~Proactive 1DM Generation Process~~

~~Proactive 1DM Reception Process~~

~~Proactive 1DM Sink Control Sk Process~~

8.8.7 On-Demand Packet Delay Measurement (DMo)

On-demand Packet Delay Measurement (DMo)

8.8.6-18.8.7.1 Overview

To support this functionality, on-demand Delay Measurement (DMM/DMR) as described in [ITU-T G.8113.1] clause 8.2.7 for ~~dual-ended~~one-way and [ITU-T G.8113.1] clause 8.2.8 for ~~single-ended~~two-way is used.

Figure 8-20 provides the different processes inside MEPs and MIPs that are involved in the ~~single-ended~~two-way Delay Measurement Protocol.

The MEP On-Demand-OAM Source insertion process is defined in clause 9.2, the MEP On-Demand OAM Sink extraction process in clause 9.2, the MIP On-Demand OAM Sink Extraction process in clause 9.4, and the MIP On-Demand OAM Source insertion process in clause 9.4. In summary, they insert and extract MT_CI OAM signals into and from the stream of MT_C_D Traffic Units and the complementing PHB signals going through an MEP and MIP;

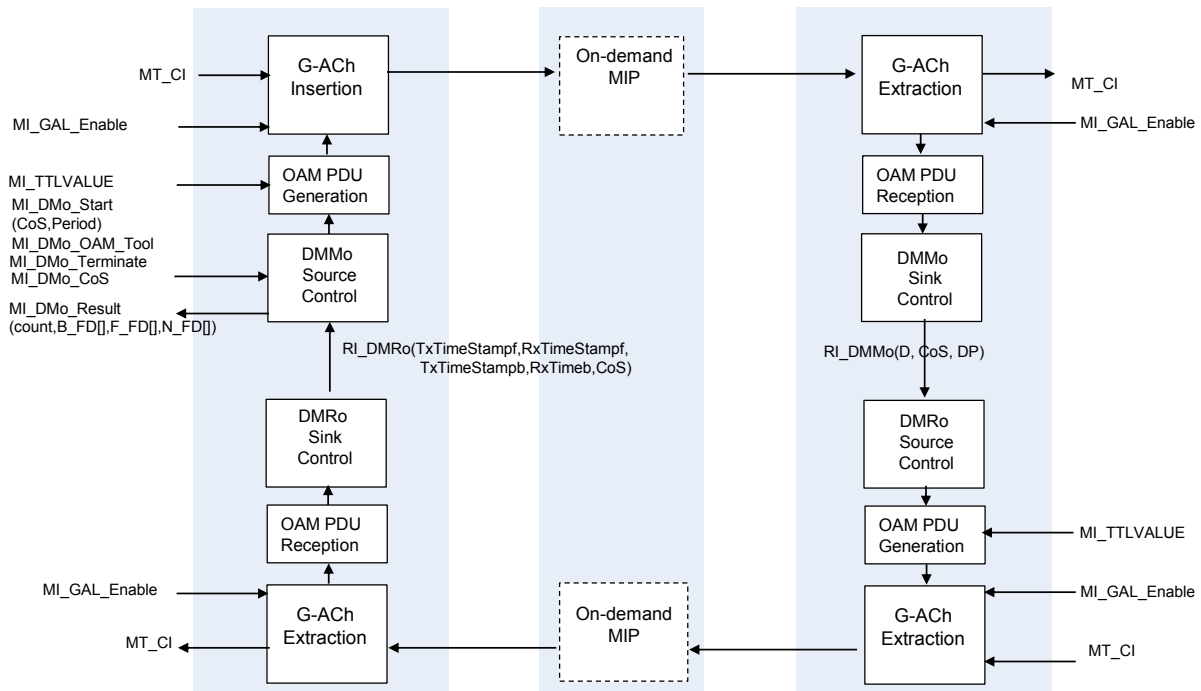

Figure 8-20/G.8121.1/Y.1381.1 – Overview of Processes involved with on-demand Delay Measurement

The DMMo source control process controls the DM protocol. The protocol is activated upon receipt of the MI_DMo_Start(CoS,Period) signal and remains activated until the MI_DMo_Terminate signal is received. The result is communicated via the MI_DMo_Result(count, B_FD[], F_FD[], N_FD[]) signal.

The DMMo source control process generates DMMo Traffic Units that pass through MIPs transparently, but are received and processed by DMMo sink control processes in MEPs. The DMRo source control process may generate a DMRo Traffic Unit in response. This DMRo Traffic Unit also passes transparently through MIPs, but is received and processed by DMRo sink control processes in MEPs.

At the Source MEP side, the DMMo source control process stamps the value of the Local Time to the TxTimeStampf field in the DMMo message when the first bit of the **framepacket** is transmitted. Note well that at the sink MEP side, the DMMo sink control process stamps the value of the Local Time to the RxTimeStampf field in the DMMo message when the last bit of the **framepacket** is received.

The DMRo source and sink control process stamps with the same way as the DMMo source and sink control process.

Figure 8-21 provides the different processes inside MEPs and MIPs that are involved in the **dual-endedOne-Way** Delay Measurement Protocol.

The MEP On-Demand OAM Source insertion process is defined in clause 9.2, the MEP On-Demand-OAM Sink extraction process in clause 9.2, the MIP On-Demand OAM Sink Extraction process in clause 9.4, and the MIP On-Demand OAM Source insertion process in clause 9.4. In summary, they insert and extract MT_CI OAM signals into and from the stream of MT_CI_D Traffic Units and the complementing PHB signals going through an MEP and MIP.

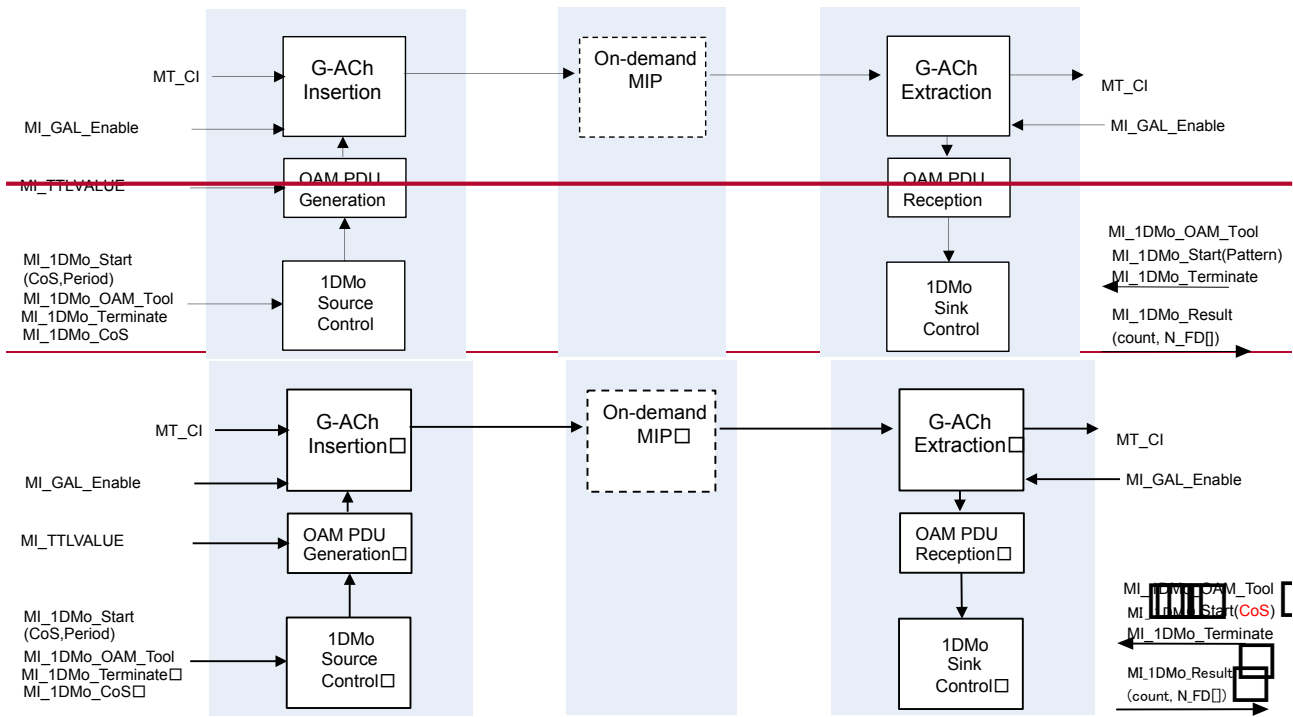

**Figure 8-21/G.8121.1/Y.1381.1 –
Overview of Processes involved with on-demand One Way Delay Measurement**

The 1DM protocol is controlled by the 1DM Source Control and 1DM Sink Control processes. The 1DM Source Control process triggers the generation of 1DM Traffic Units upon the receipt of an MI_1DM_Start(iPHB, oPHB, Period) signal. The 1DM Sink Control process processes the information from received 1DM Traffic Units after receiving the MI_1DM_Start(iPHB, oPHB, Period) signal.

The 1DM Source control process generates 1DM messages that pass transparently through MIPs and are received and processed by the 1DM Sink Control Process in MEPs.

At the Source MEP side, The 1DM source control process stamps the value of the Local Time to the TxTimeStampf field in the 1DM message when the first bit of the **framepacket** is transmitted. Note well that at the sink MEP side, the 1DM sink control process records the value of the Local Time when the last bit of the **framepacket** is received.

8.8.6-28.8.7.2 On-demand DM Source Control Process

The behaviour of the DMMo Control Process is defined in Figure 8-22.

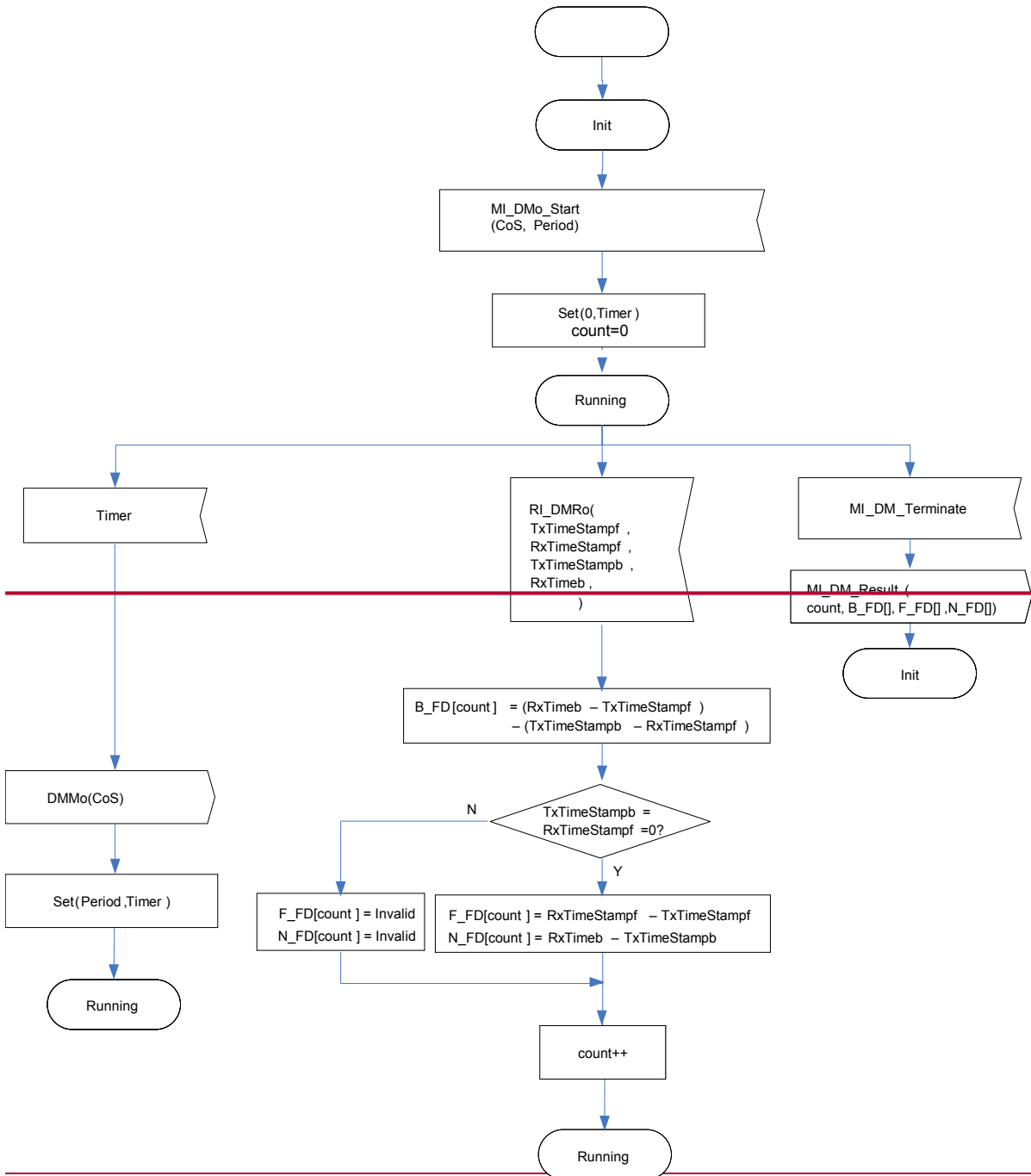

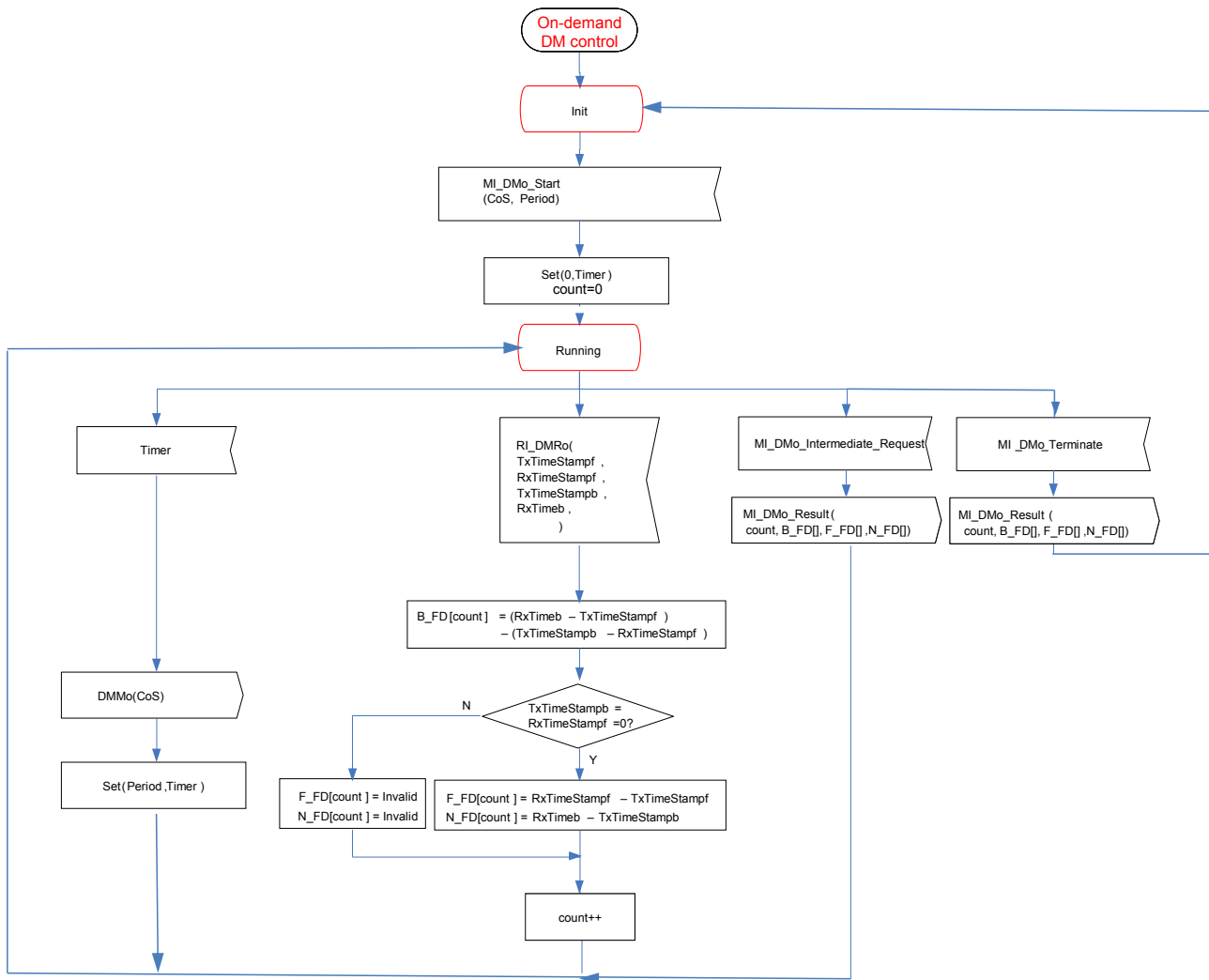

Figure 8-22/G.8121.1/Y.1381.1 – DMMo Control Behaviour

[Remove “Length” from Figure, Also Flow TLV should be removed and DMMo(CoS, 0, TLV) should be DMMo(CoS)]

Upon receipt of the MI_DMo_Start(CoS, ~~Length~~, Period), the DM protocol is started. Every Period the generation of a DMM ~~framepacket~~ is triggered (using the DMMo(CoS, ~~0, TLV~~) signal), until the MI_DMo_Terminate signal is received. Upon receipt of a DMR Traffic Unit the Delay value recorded by this particular DMRo Traffic Unit is calculated. This result is reported using the MI_DMo_Result(count, B_FD[], F_FD[], N_FD[]) signal after the receipt of the MI_DMo_Terminate signal. Note that the measurements of F_FD and N_FD are not supported by peer MEP if both TxTimeStamb and TxTimeStampf are zero.

8.8.6-38.8.7.3 On-demand DMM Generation Process

The behaviour of the DMM Generation Process that is in DMMo Source control process is defined in Figure 8-23

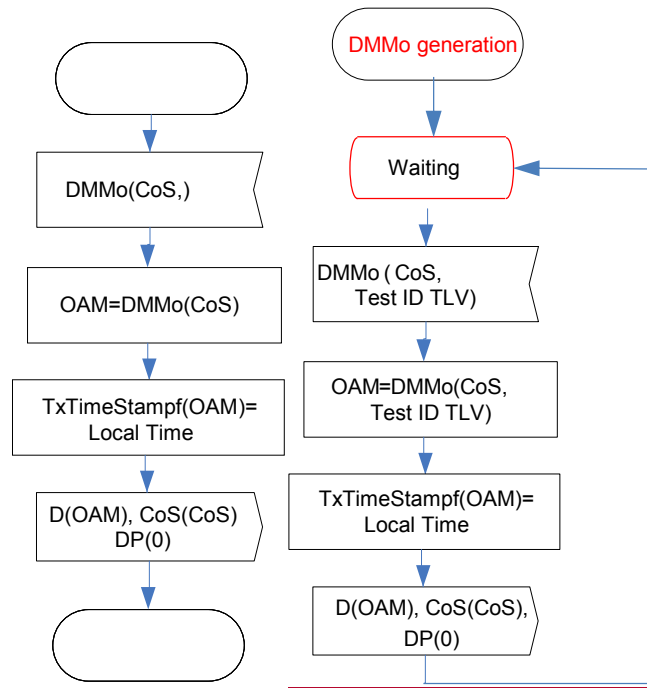

Figure 8-23/G.8121.1/Y.1381.1 – DMMo Generation Behaviour
~~[Remove TLV]~~

Upon receiving the DMMo(CoS, ~~Type, TLV~~), a single DMM Traffic Unit is generated together with the complementing CoSP and DPDE signals. The DA of the generated Traffic Unit is determined by the DMM(DA) signal. The TxTimeStampf field is assigned the value of the local time.

The CoSP signal value is defined by DMMo(CoS). ~~The DE signal is set to 0. The Type signal is set to 1 if it is the proactive OAM, or set to 0 if it is the on-demand OAM operation. The Test ID signal is determined by the DMM signal. The TLV signal is determined by the DMM signal.~~

8.8.6.48.8.7.4 On-demand DMM Reception Process

The DMMo Sink Control Process processes the received DMMo Traffic Units and the complementing CoSP and DPDE signals. The behaviour is defined in Figure 8-24.

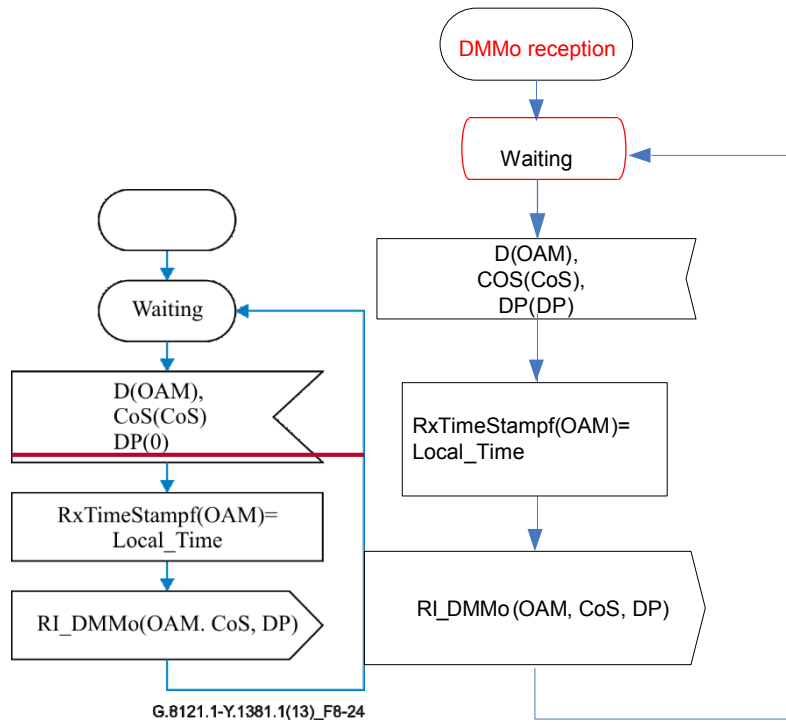

Figure 8-24/G.8121.1/Y.1381.1 – DMMo Reception Behaviour

Traffic Unit and the complementing CoS and DP signals are forwarded as Remote Information to the DMR Generation Process.

8.8.6-58.8.7.5 On-demand DMR Generation Process

The On-demand DMR Generation Process that is in DMRo Source control process generates a DMRo Traffic Unit and its complementing CoS and DP signals. The behaviour is defined in Figure 8-25.

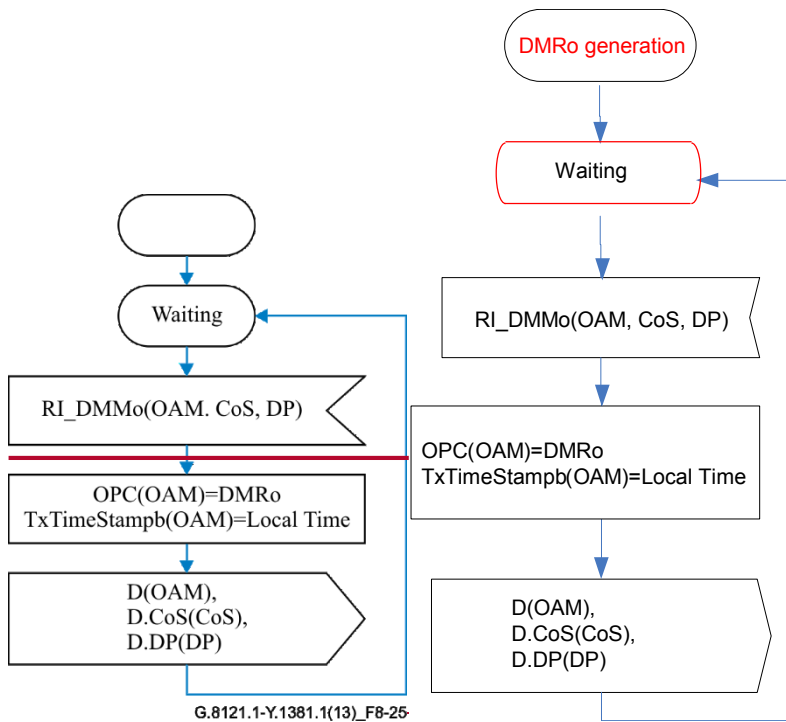

Figure 8-25/G.8121.1/Y.1381.1 – On-demand DMR Generation Behaviour

Upon the receipt of Remote Information containing a DMMo Traffic Unit, the DMR generation process generates a DMR Traffic Unit and forwards it to the OAM insertion Process.

As part of the DMR generation the:

- The Opcode is changed into DMRo Opcode;
- The TxTimeStampb field is assigned the value of the Local Time.
- All the other fields (including TLVs and padding after the End TLV) are copied from the Remote Information containing the original DMM Traffic Unit.

~~The resulting DMR Traffic Unit is shown in Figure 8-30.~~

~~NOTE—In the generated DMR, in the OAM (MEP) Insertion process, the SA will be overwritten with the Local MAC address, and the MEL will be over written with MI_MEL.~~

The TLVs are copied from the Remote Information containing the original DMM Traffic Unit. If multiple TLVs exist, the order of the TLVs is unchanged.

~~8.8.6.6~~8.8.7.6 On-demand DMR Reception Process

The On-demand DMR Reception Process that is in DMRo Sink control process processes the received DMRo Traffic Units and the complementing CoS and DP signals. The behaviour is defined in Figure 8-26.

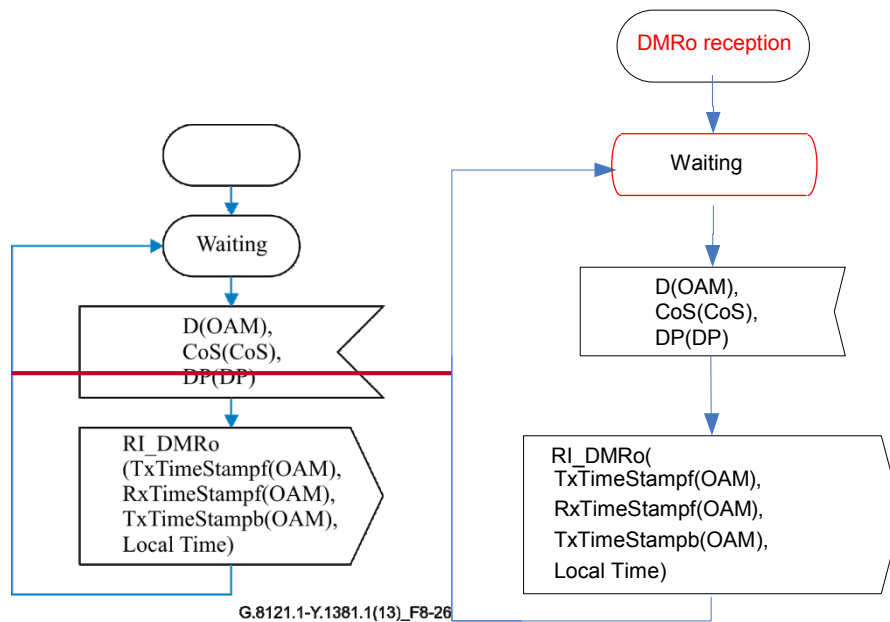

Figure 8-26/G.8121.1/Y.1381.1 – DMR Reception Behaviour

If the DMR Traffic Unit is processed, the TxTimeStampf, RxTimeStampf, TxTimeStampb and Test ID are extracted from the Traffic Unit and signalled together with the Local Time.

~~8.8.6.7~~8.8.7.7 On-Demand 1DM Source Control Process

Figure 8-27 shows the behaviour of the on-demand 1DM Source Control Process. Upon receipt of the MI_1DMo_Start (D, CoS, **Length**, Period) signal the 1DM protocol is started. The protocol will run until the receipt of the MI_1DM_Terminate signal.

If the On-demand DM protocol is running every Period (as specified in the MI_1DMo_Start signal) the generation of a 1DMo message is triggered by generating the 1DMo(~~D~~, CoS, ~~0~~, ~~TLV~~) signal towards the 1DMo Generation Process.

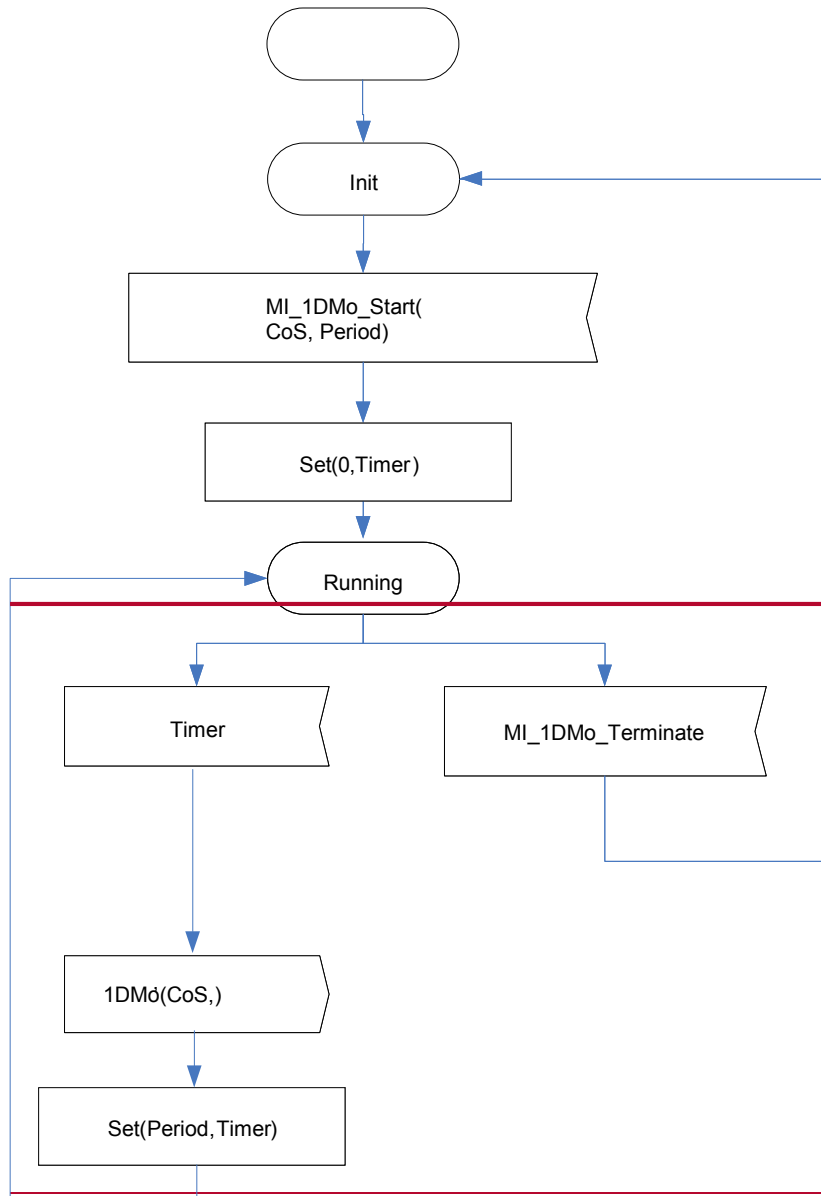

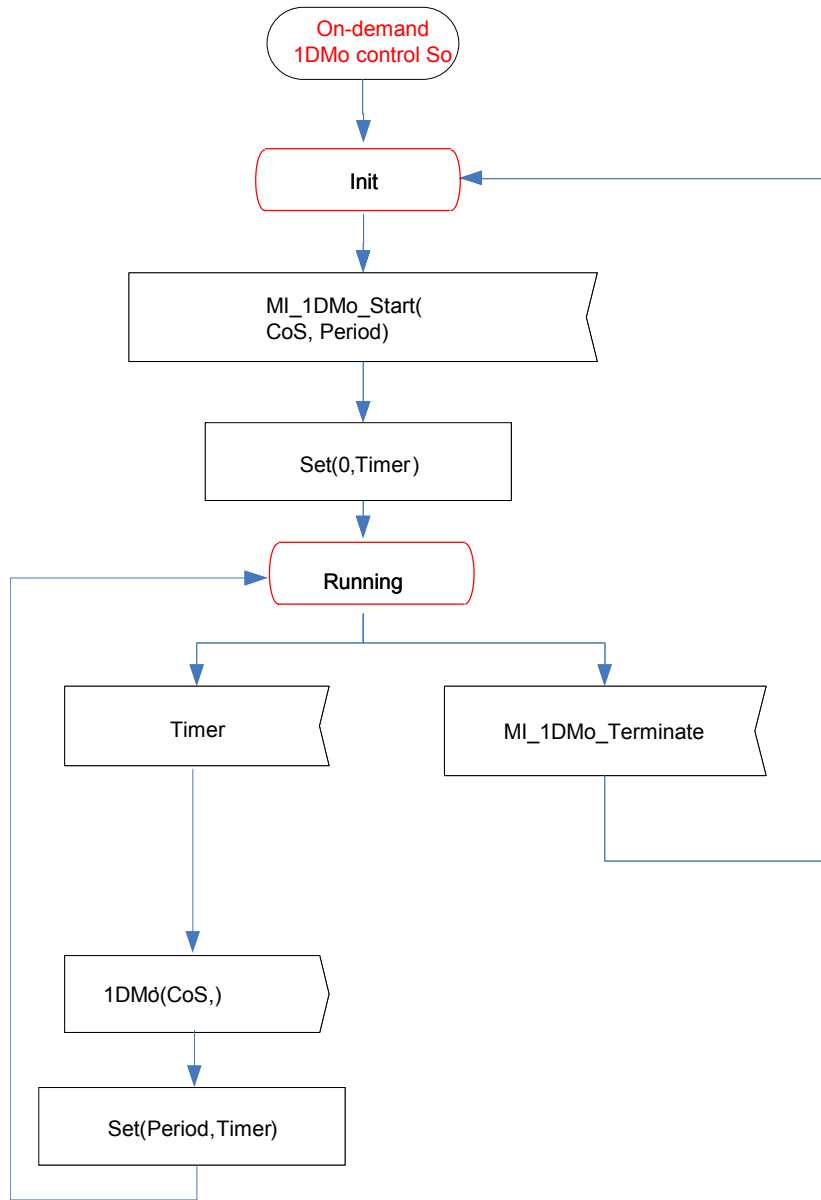

Figure 8-27/G.8121.1/Y.1381.1 – On-demand 1DM Source Control Behaviour *remove length,*
tlv

8.8.6.8.8.7.8 On-Demand 1DM Generation Process

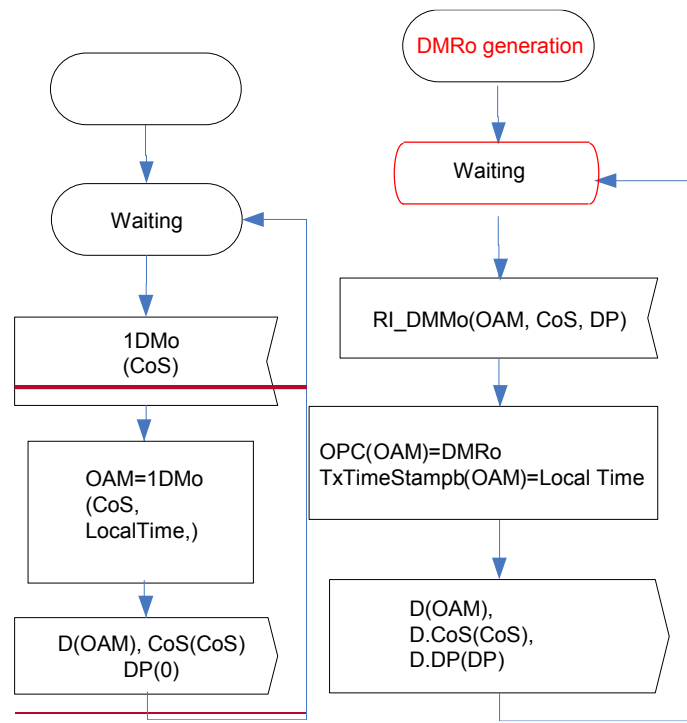

Figure 8-28/G.8121.1/Y.1381.1 – 1DM Generation Behaviour *remove length*

Figure 8-28 shows the On-demand 1DM Generation Process in 1DM Source control process. Upon receiving the 1DM(CoS, ~~Type~~, ~~TLV~~) signal a single 1DM Traffic Unit is generated by the OAM=1DM (CoS, ~~Type~~, LocalTime, ~~TLV~~) call.

Together with this 1DMo Traffic Unit the complementing P and DE signals are generated. The TxTimeStamp field is assigned the value of the Local Time. The value of the P signal is determined by the 1DM(CoS) signal. The DP signal is set to 0.

8.8.6.9.8.7.9 On-Demand 1DM Reception Process

The On-demand 1DM Reception Process in 1DM Sink control process processes the received 1DMo Traffic Units and the complementing P and CoS signals. The behaviour is defined in Figure 8-29.

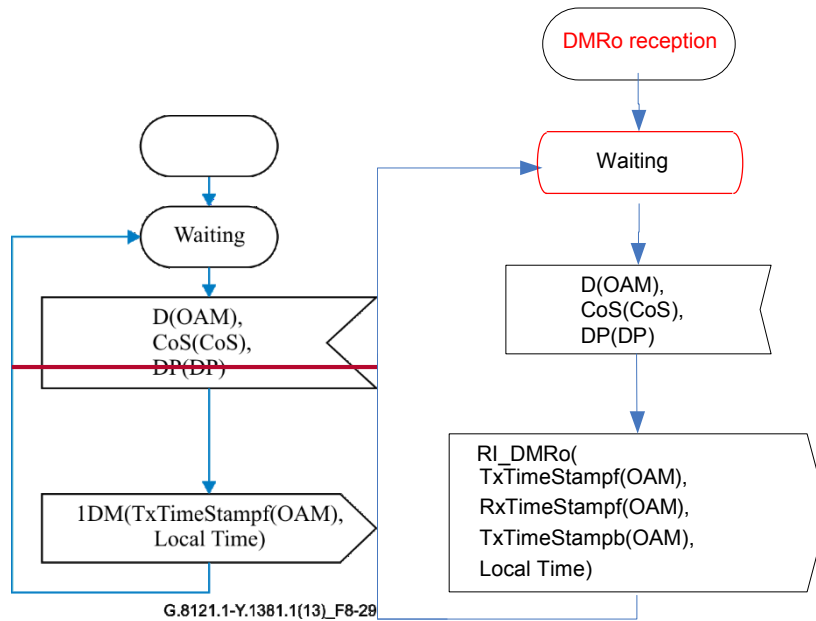

Figure 8-29/G.8121.1/Y.1381.1 – 1DM Reception Behaviour

If the 1DMo Traffic Unit is processed and TxTimeStampf fields are extracted and forwarded to the 1DMo Control_Sk process together with the Local Time using the 1DMo (TxTimeStampf, RxTimef) signal.

8.8.6.108.8.7.10 On-Demand 1DM Sink Control_Sk Process

Figure 8-30 shows the behaviour of the on-demand 1DM Sink Control_Sk process. The protocol runs until the receipt of the MI_1DM_Terminate signal.

While running the process processes the received 1DMo(TxTimeStampf,RxTimef,) information. Otherwise the Delay from the single received 1DM Traffic Unit is calculated. This result is reported using the MI_1DMo_Result(count, N_FD[]) signal after the receipt of the MI_1DM_Terminate signal.

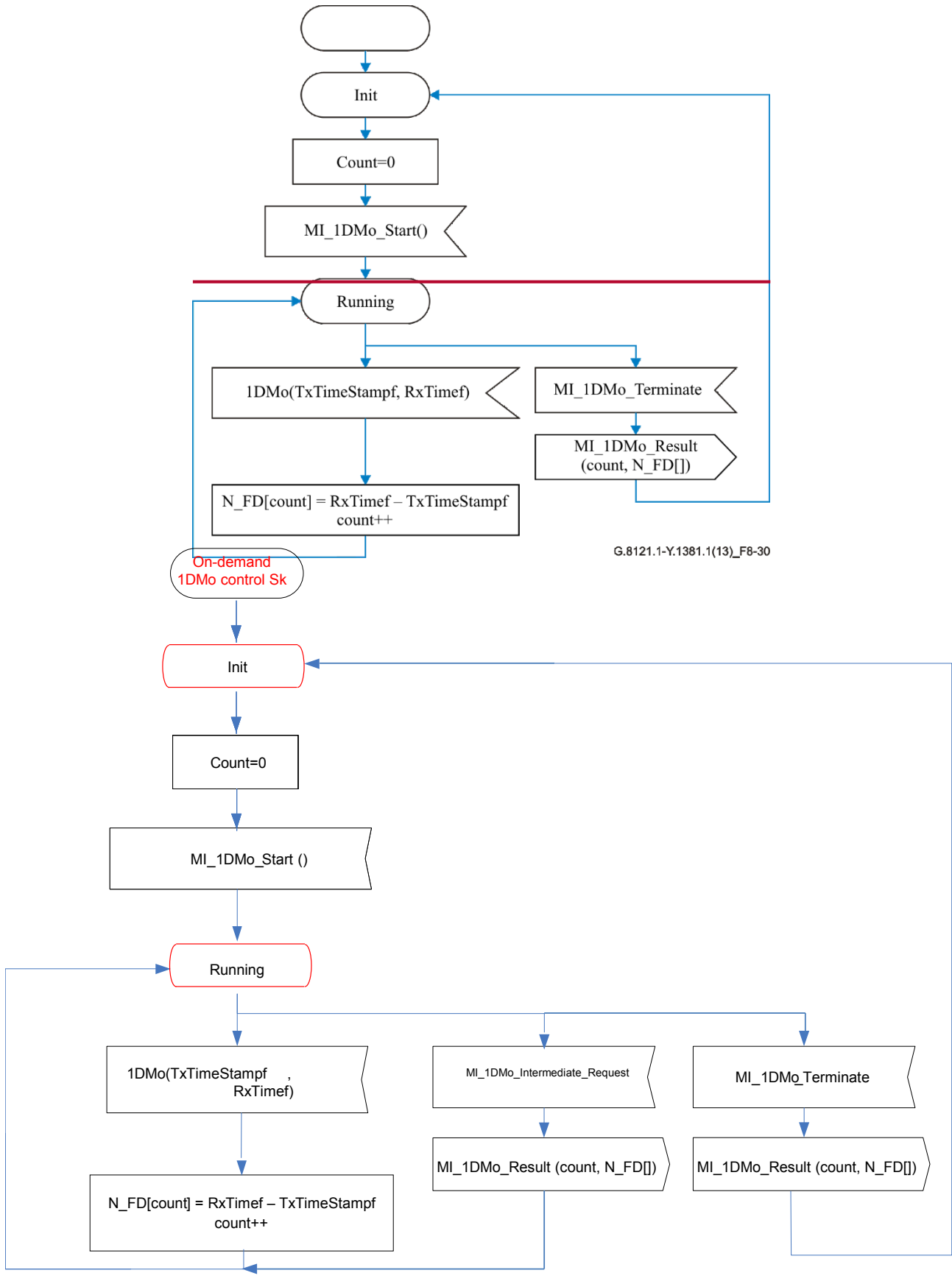

Figure 8-30/G.8121.1/Y.1381.1 – On-demand 1DM Control_Sk Process

8.8.7.8.8.8 Test (TST) Process

8.8.7.18.8.8.1 Overview

To support OAM for dual-ended Throughput Test, TST as described in clause 8.2.5 of [ITU-T G.8113.1] can be used. The control process specific to Throughput Test is for further study.

Figure 8-31 provides the different processes inside MEPs and MIPs that are involved in the Test Protocol.

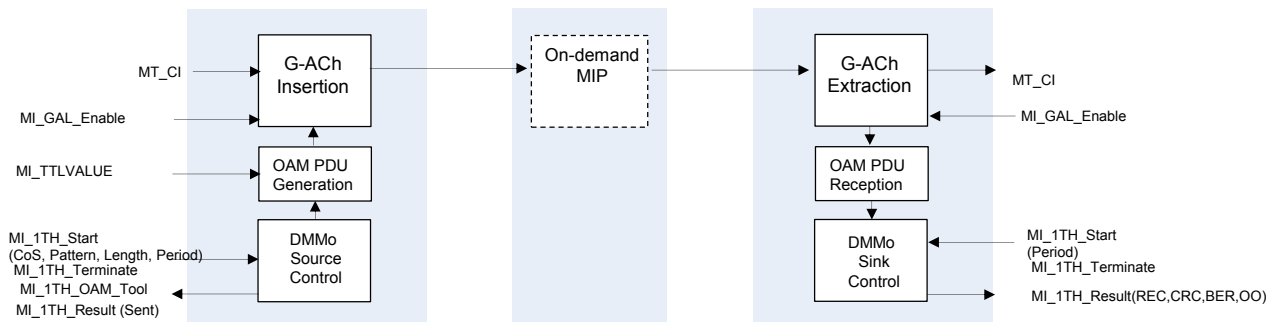

Figure 8-31/G.8121.1/Y.1381.1 – Overview of Processes involved with Test Protocol

~~remove CoS, Pattern, and Length from 1TH_Start_Sk~~

The TST(1TH) protocol is controlled by the TST(1TH) Source Control and TST(1TH) Sink Control processes. The TST(1TH) Source Control process triggers the generation of TST(1TH) Traffic Units after the receipt of an MI_1TH_Start (CoS, Pattern, Length, Period) signal. The TST(1TH) Sink Control process processes the information from received TST Traffic Units after receiving the MI_1TH_Start (Pattern) signal.

The TST Source control process generates TST messages that pass transparently through MIPs and are received and processed by the TST Sink Control Reception Process in MEPs.

The processes are defined below.

8.8.7.28.8.8.2 TST Source Control Process

Figure 8-32 defines the behaviour of the TST Source Control Process. This process triggers the transmission of TST Traffic Units after receiving the MI_Test(CoS, DP, Pattern, Length, Period) signal. The transmission of TST(1TH) Traffic Units is triggered by the generation of the 1TH(CoS, DP, TLV, TID) signal. This is continued until the receipt of the MI_1TH_Terminate signal. After receiving this signal the number of triggered TST Traffic Units is reported back using the MI_1TH_Result(Sent) signal.

The TLV field of the 1TH ~~frame~~packets is determined by the Generate(Pattern, Length) function. For Pattern the following types are defined:

- 0: “Null signal without CRC-32”
- 1: “Null signal with CRC-32”
- 2: “PRBS 2³¹-1 without CRC-32”
- 3: “PRBS 2³¹-1 with CRC-32”

The Length parameter determines the length of the generated TLV.

Generate(Pattern, Length) generates a Test TLV with length 'Length' to be included in the 1TH framepacket. Therefore, this TLV is passed using the 1TH(CoS,DP,TLV,TID) signal to the TST Generation Process.

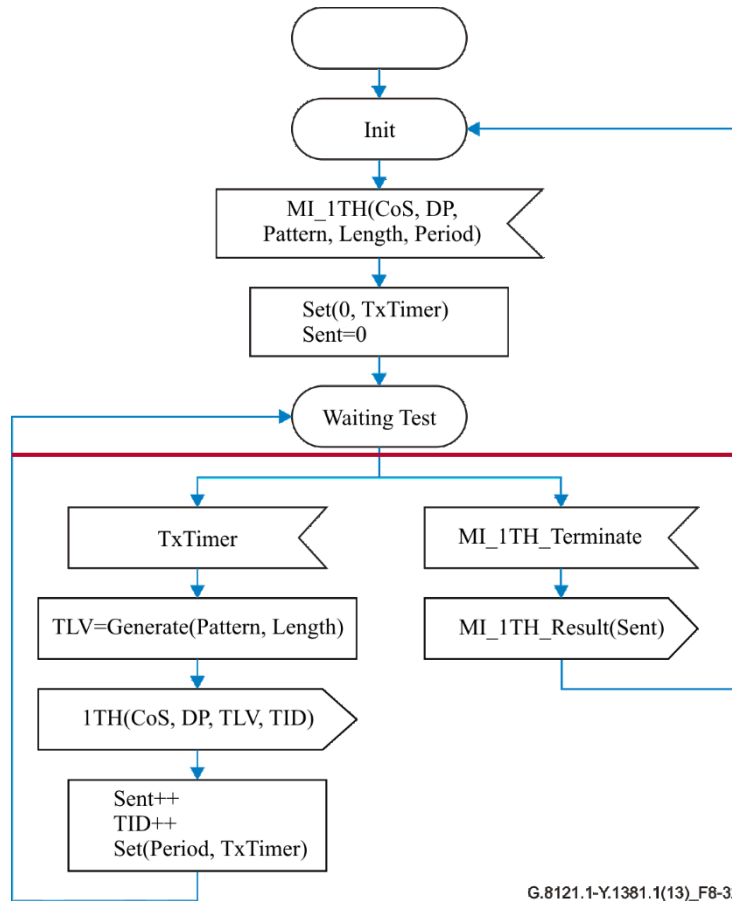

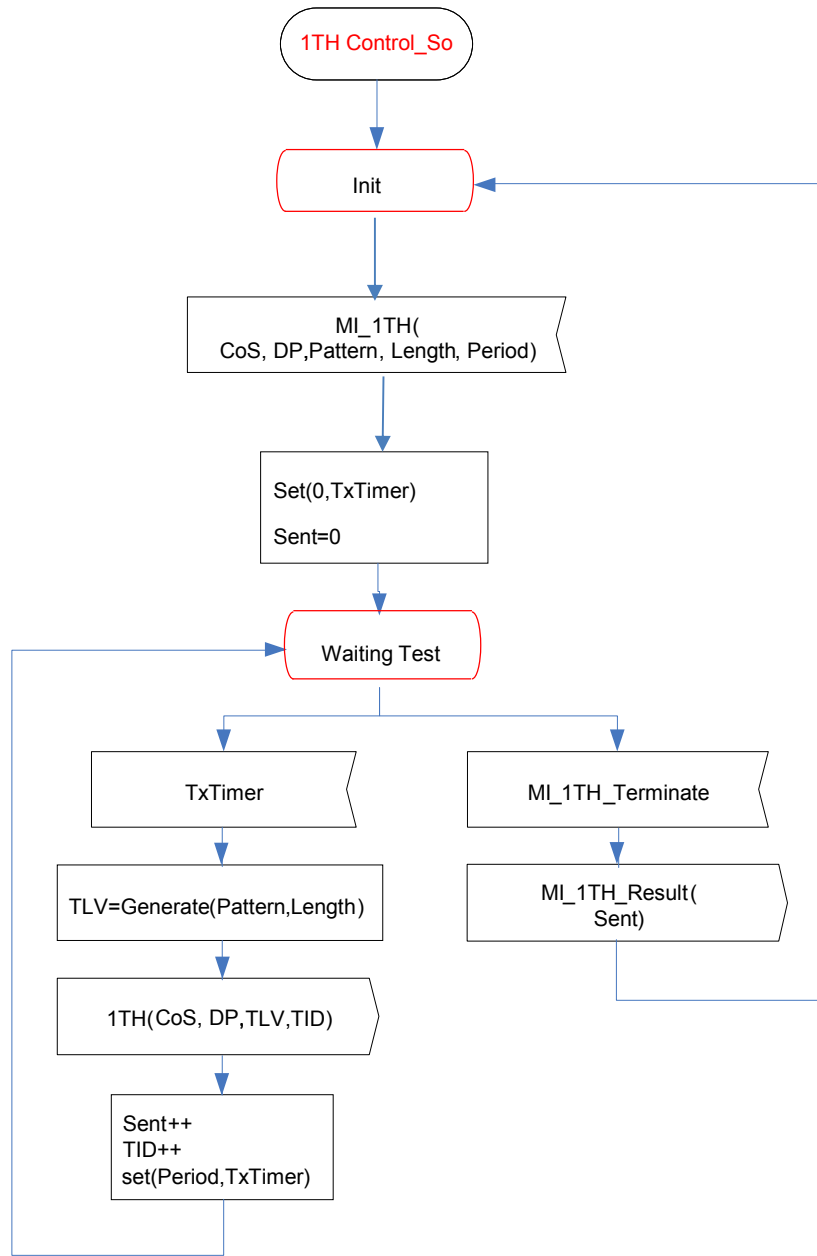

Figure 8-32/G.8121.1/Y.1381.1 – TST Source Control Behaviour

8.8.7.38.8.8.3 TST Generation Process

Figure 8-33 defines the behaviour of the TST Generation Process in Source control process.

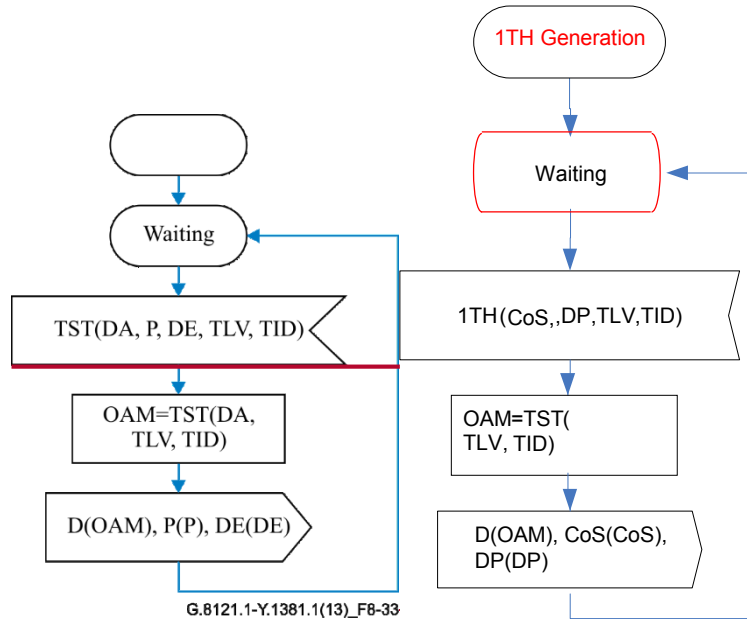

Figure 8-33/G.8121.1/Y.1381.1 – TST Generation Behaviour

Upon receiving the 1TH(CoS,DP,TLV,TID), a single 1TH Traffic Unit is generated together with the complementing CoS and DP signals. The 1TH Traffic Unit is generated by:

OAM=1TH(TLV,TID).

The Transaction Identifier field gets the value of 1TH(TID); the TLV field is populated with TST(TLV).

The CoS signal is determined by the 1TH(CoS) signal.

The DP signal is determined by the 1TH(DP) signal.

8.8.7.48.8.8.4 TST Reception Process

Figure 8-34 defines the behaviour of the TST Reception Process that is in Sink control process.

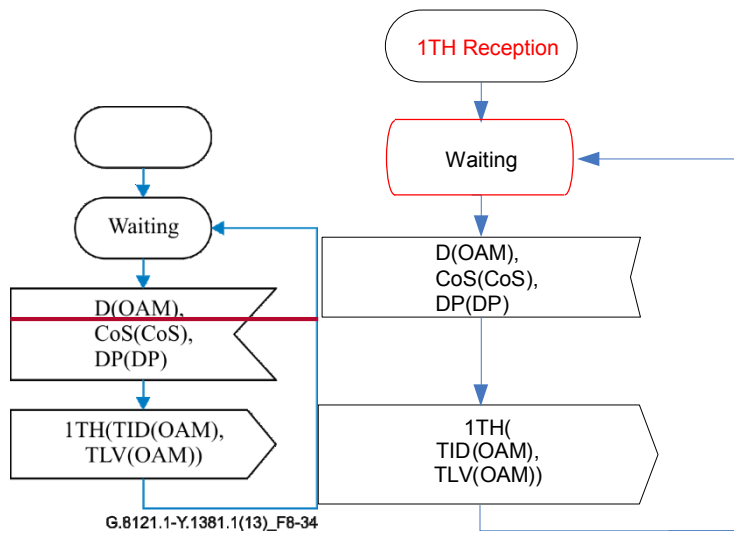

Figure 8-34/G.8121.1/Y.1381.1 – TST Reception Behaviour

8.8.7.58.8.8.5 TST Sink Control Process

Figure 8-35 shows the behaviour of the TST Sink Control process. The MI_1TH_Start signal starts the processing of 1TH messages coming from a MEP. The protocol is running until the receipt of the MI_1TH_Terminate signal.

While running, the process processes the received 1TH(rTLV,TID) information.

First, the received 1TH counter is incremented by one (REC++).

Furthermore, if the TLV contains a CRC (Pattern 1 or 3), the CRC counter is incremented by one (CRC++) if the CRC check fails.

The function Check(Pattern, TLV) compares the received Test Pattern with the expected Test Pattern. If there is a mismatch the BERR counter is incremented by one.

If the TID value from the RI_LBR signal does not follow the last received TID value the counter for out of order **framepackets** is incremented by one (OO++).

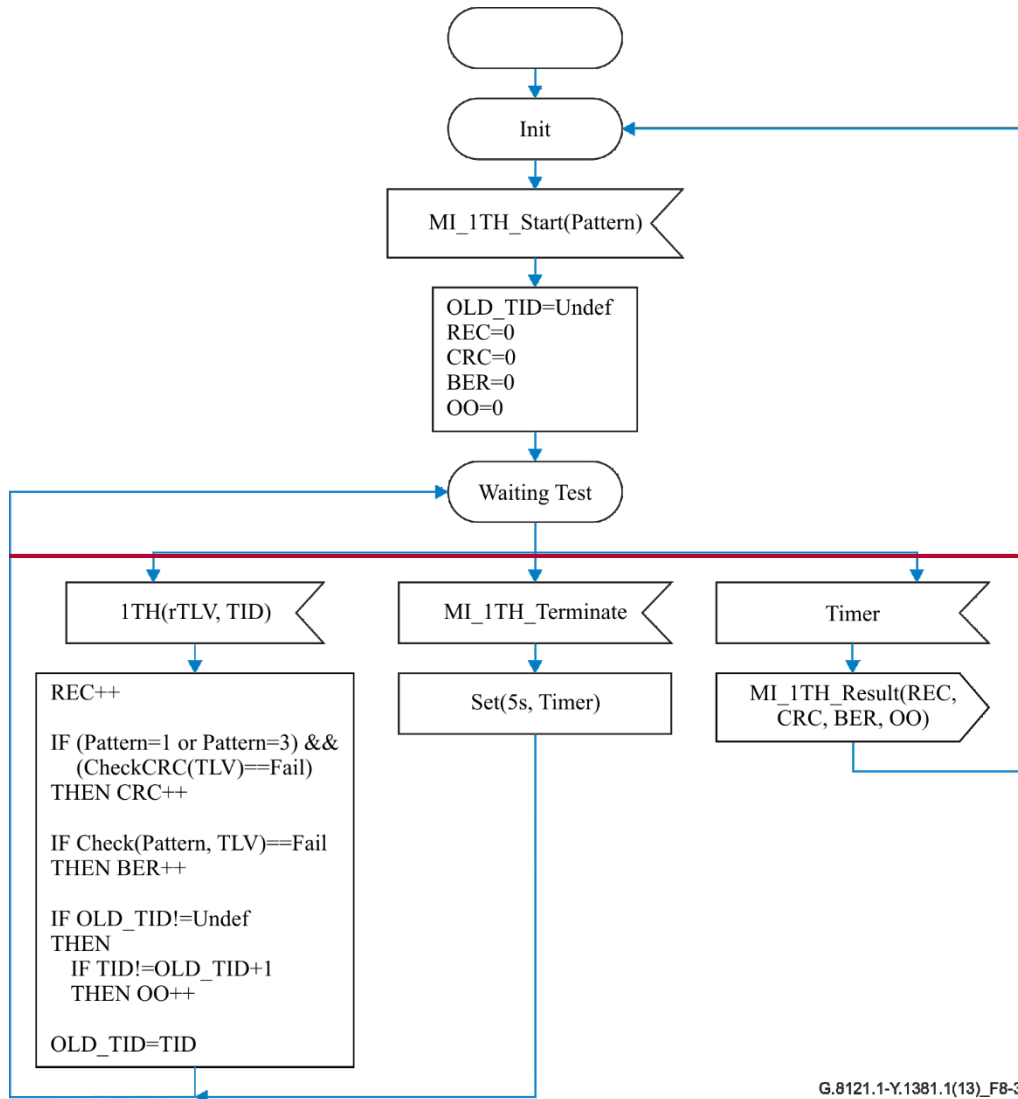

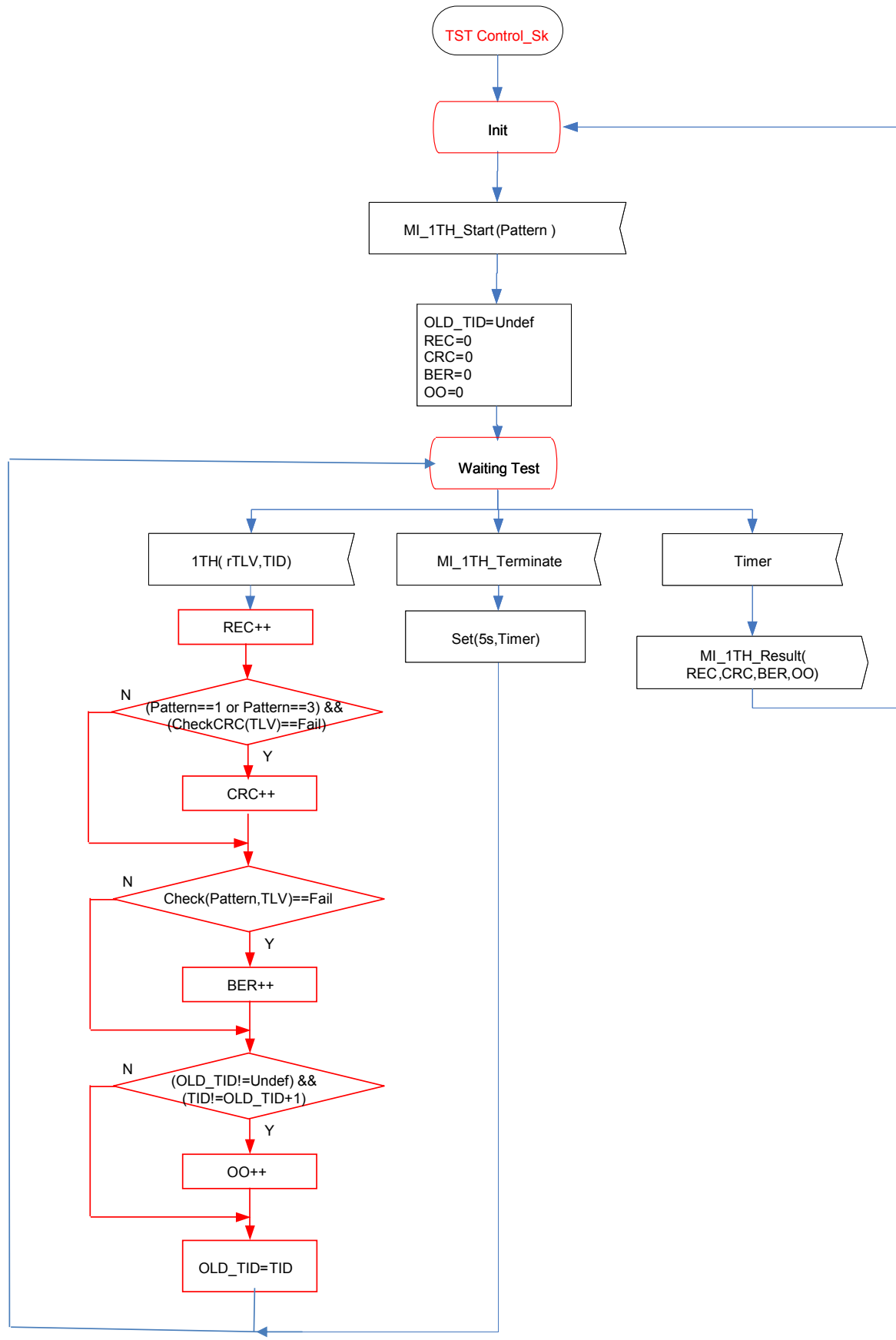

Figure 8-35/G.8121.1/Y.1381.1 – TST Sink Control Behaviour

8.8.88.8.9 Route Tracing (RT)

For further study

8.8.10 LCK/AIS Reception

See clause 8.8.10 of [ITU-T G.8121]

9 MPLS-TP processes

9.1 Connection Functions (MT_C)

See the clause 9.1 in [ITU-T G.8121]

9.1.1 Sub-network connection protection process

See the clause 9.1.1 in [ITU-T G.8121]

9.2 Termination functions

9.2.1 MPLS-TP Trail Termination function (MT_TT)

The bidirectional MPLS-TP Trail Termination (MT_TT) function terminates the MPLS-TP OAM to determine the status of the MPLS-TP (sub)layer trail. The MT_TT function is performed by a co-located pair of the MPLS-TP trail termination source (MT_TT_So) and sink (MT_TT_Sk) functions as shown in Figure 9-1.

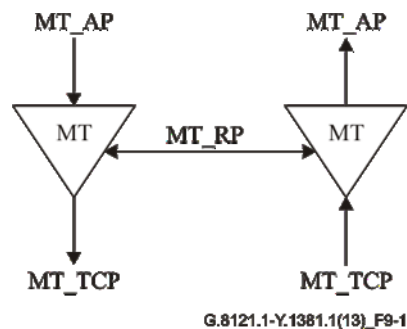

Figure 9-1/G.8121.1/Y.1381.1 – MT_TT

9.2.1.1 MPLS-TP Trail Termination Source function (MT_TT_So)

The MT_TT_So function determines and inserts the TTL value in the shim header TTL field and adds MPLS-TP OAM for pro-active monitoring to the MT_AI signal at its MT_AP.

• **Symbol:**

The MT_TT_So function symbol is shown in Figure9-2.

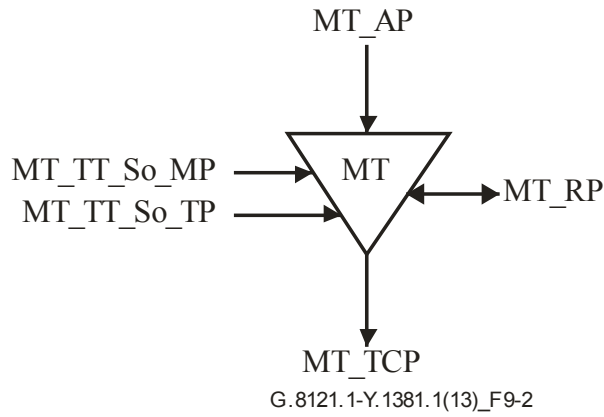

Figure9-2/G.8121.1/Y.1381.1 –MT_TT_So function

• **Interfaces:**

Table 9-1/G.8121.1/Y.1381.1 – MT_TT_So inputs and outputs

Input(s)	Output(s)
<p>MT_AP: MT_AI_D MT_AI_PHB MT_AI_LStack</p> <p>MT_RP:</p> <p>MT_RI_CC_RDI MT_RI_CC_BlK MT_RI_CC_RTxFCI MT_RI_CC_TRxFCf <u>MT_RI_OAM_Info(D,CoS,DP)</u></p> <p>MT_TT_So_MP: MT_TT_So_MI_GAL_Enable MT_TT_So_MI_TTLVALUE MT_TT_So_MI_MEG_ID MT_TT_So_MI_MEP_ID</p> <p>MT_TT_So_MI_CC_OAM_Tool MT_TT_So_MI_RDI_OAM_Tool MT_TT_So_MI_CC_Enable MT_TT_So_MI_LMC_Enable</p> <p>MT_TT_So_MI_CC_CoS MT_TT_So_MI_CC_Period <u>MT_TT_So_MI_CC_Enable</u></p>	<p>MT_TCP: MT_CI_D MT_CI_oPHB MT_CI_iPHB MT_CI_LStack</p> <p>MT_RP:</p>

MT_TT_So_MI_LMp_OAM_Tool
MT_TT_So_MI_LML_Enable[1...M_{LMp}]
MT_TT_So_MI_LMp_Period[1...M_{LMp}]
MT_TT_So_MI_LMp_CoS[1...M_{LMp}]

MT_TT_So_MI_DMp_OAM_Tool
MT_TT_So_MI_DMp_Enable[1...M_{DMp}]
MT_TT_So_MI_DMp_Period[1...M_{DMp}]
MT_TT_So_MI_DMp_Test_ID[1...M_{DMp}]
MT_TT_So_MI_DMp_CoS[1...M_{DMp}]
MT_TT_So_MI_DMp_Length[1...M_{DMp}]

MT_TT_So_MI_1DMp_OAM_Tool
MT_TT_So_MI_1DMp_Enable[1...M_{1DMp}]
MT_TT_So_MI_1DMp_Period[1...M_{1DMp}]
MT_TT_So_MI_1DMp_Test_ID[1...M_{1DMp}]
MT_TT_So_MI_1DMp_Length[1...M_{1DMp}]
MT_TT_So_MI_1DMp_CoS[1...M_{1DMp}]

MT_TP:
MT_TT_So_TI_TimeStampI

• **Processes:**

The processes associated with the MT_TT_So function are as depicted in Figure 9-3.

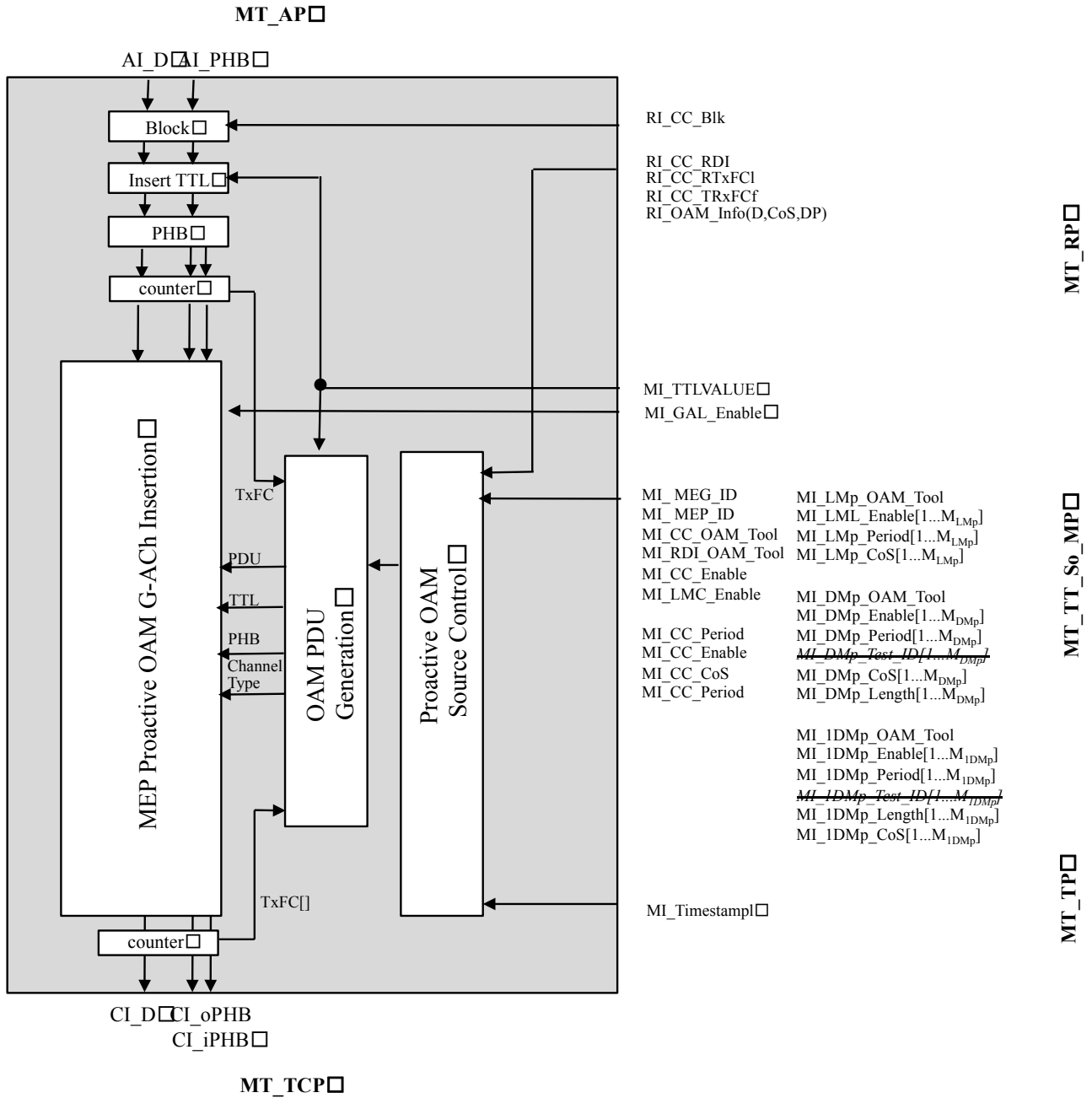

Figure 9-3/G.8121.1/Y.1381.1 –MT_TT_So process diagram

[Remove Lstack]

PHB: See 9.2 in [ITU-T G.8121]

Extract TTL: See 9.2 in [ITU-T G.8121]

Block: See 9.2 in [ITU-T G.8121]

Counter: It is used to count framepackets for proactive loss measurements with CCM. See 8.8.1.4 for the upper counter in Figure 9-3 and 8.8.4.7 for the lower counter in Figure 9-3

G-Ach/GAL Insertion: See 8.1 in [ITU-T G.8121]

Pro-active OAM Source Control: This process consists of following sub-processes as shown Figure 9-4. These details are in clause 8.8.1.

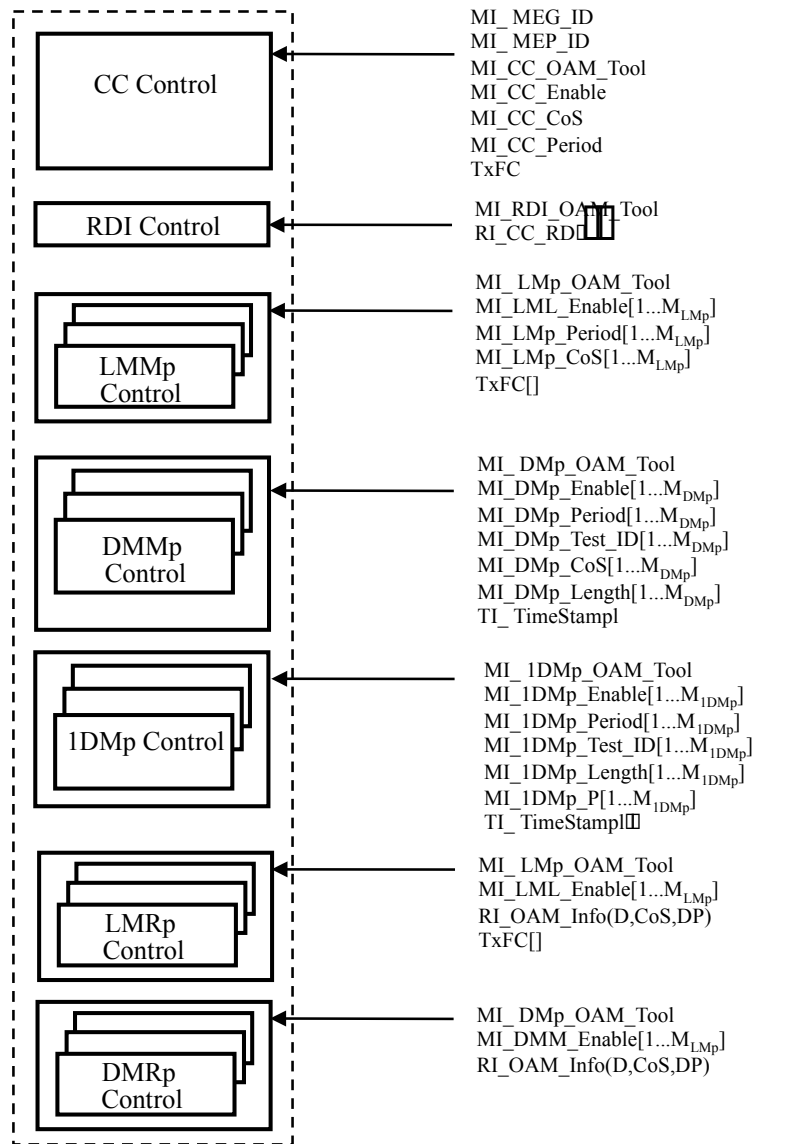

Figure 9-4/G.8121.1/Y.1381.1 – Pro-active OAM Source Control Process

OAM PDU Generation Process: See 9.2 in [ITU-T G.8121]

• **Defects:**

None.

• **Consequent actions:**

None.

• **Defect correlations:**

None.

• **Performance monitoring:**

None.

9.2.1.2 MPLS-TP Trail Termination Sink function (MT_TT_Sk)

The MT_TT_Sk function reports the state of the MPLS-TP Trail (Network Connection). It extracts MPLS-TP trail OAM - for pro-active monitoring - from the MPLS-TP signal at its MT_TCP, detects defects, counts during 1-second periods errors and defects to feed Performance Monitoring when connected and forwards the defect information as backward indications to the companion MT_TT_So function.

Note – The MT_TT_Sk function extracts and processes one level of MPLS-TP OAM irrespective of the presence of more levels.

• **Symbol:**

The MT_TT_So function symbol is shown in Figure 9-5.

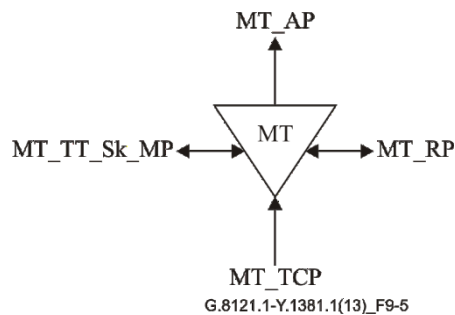

Figure 9-5/G.8121.1/Y.1381.1 – MT_TT_Sk function

• **Interfaces:**

Table 9-2/G.8121.1/Y.1381.1 – MT_TT_Sk inputs and outputs

Input(s)	Output(s)
<p>MT_TCP: MT_CI_D MT_CI_iPHB MT_CI_oPHB MT_CI_SSF MT_CI_Lstack</p> <p>MT_RP:</p> <p>MT_TT_Sk_MP: MT_TT_Sk_MI_GAL_Enable MT_TT_Sk_MI_MEG_ID MT_TT_Sk_MI_PeerMEP_ID MT_TT_Sk_MI_CC_OAM_Tool MT_TT_Sk_MI_RDI_OAM_Tool</p> <p>MT_TT_Sk_MI_CC_Enable MT_TT_Sk_MI_LMC_Enable</p> <p>MT_TT_Sk_MI_CC_Period MT_TT_Sk_MI_CC_CoS</p> <p>MT_TT_Sk_MI_Get_SvdCC</p> <p>MT_TT_Sk_MI_LM_DEGM MT_TT_Sk_MI_LM_M MT_TT_Sk_MI_LM_DEGTHR MT_TT_Sk_MI_LM_TFMIN</p> <p><u>MT_TT_Sk_MI_LMp_OAM_Tool[1... M_{LMp}]</u> <u>MT_TT_Sk_MI_LML_Enable[1... M_{LMp}]</u> <u>MT_TT_Sk_MI_LMp_CoS[1... M_{LMp}]</u></p> <p><u>MT_TT_Sk_MI_DMp_OAM_Tool[1... M_{DMp}]</u> <u>MT_TT_Sk_MI_DMp_Enable[1... M_{DMp}]</u> <u>MT_TT_Sk_MI_DMp_CoS[1... M_{DMp}]</u></p> <p><u>MT_TT_Sk_MI_1DMp_OAM_Tool[1...M_{1DMp}]</u> <u>MT_TT_Sk_MI_1DMp_Enable[1...M_{1DMp}]</u> <u>MT_TT_Sk_MI_1DMp_Test_ID[1...M_{1DMp}]</u></p> <p><u>MT_TT_Sk_MI_1second</u></p> <p>MT_TP: <u>MT_TT_Sk_TI_TimeStampI</u></p>	<p>MT_AP: MT_AI_D MT_AI_PHB MT_AI_TSF MT_AI_TSD MT_AI_AIS</p> <p>MT_AI_LStack</p> <p>MT_RP: MT_RI_CC_RDI MT_RI_CC_BlK MT_RI_CC_RxFCI MT_RI_CC_TxFCf</p> <p><u>MT_RI_OAM_Info(D,CoS,DP)</u></p> <p>MT_TT_Sk_MP: MT_TT_Sk_MI_SvdCC MT_TT_Sk_MI_cSSF MT_TT_Sk_MI_cLCK MT_TT_Sk_MI_cLOC MT_TT_Sk_MI_cMMG MT_TT_Sk_MI_cUNM MT_TT_Sk_MI_cUNP</p> <p>MT_TT_Sk_MI_cUNC</p> <p>MT_TT_Sk_MI_cDEG MT_TT_Sk_MI_cRDI MT_TT_Sk_MI_pN_LF MT_TT_Sk_MI_pN_TF MT_TT_Sk_MI_pF_LF MT_TT_Sk_MI_pF_TF</p> <p><u>MT_TT_Sk_MI_pN_LF[1...P]</u> <u>MT_TT_Sk_MI_pN_TF[1...P]</u> <u>MT_TT_Sk_MI_pF_LF[1...P]</u> <u>MT_TT_Sk_MI_pF_TF[1...P]</u> <u>MT_TT_Sk_MI_pF_DS</u> <u>MT_TT_Sk_MI_pN_DS</u> <u>MT_TT_Sk_MI_pB_FD[1...P]</u> <u>MT_TT_Sk_MI_pB_FD[1...P]</u> <u>MT_TT_Sk_MI_pN_FD[1...P]</u> <u>MT_TT_Sk_MI_pN_FD[1...P]</u> <u>MT_TT_Sk_MI_pF_FD[1...P]</u> <u>MT_TT_Sk_MI_pF_FD[1...P]</u></p>

• **Processes:**

The processes associated with the MT_TT_Sk function are as depicted in Figure 9-6.

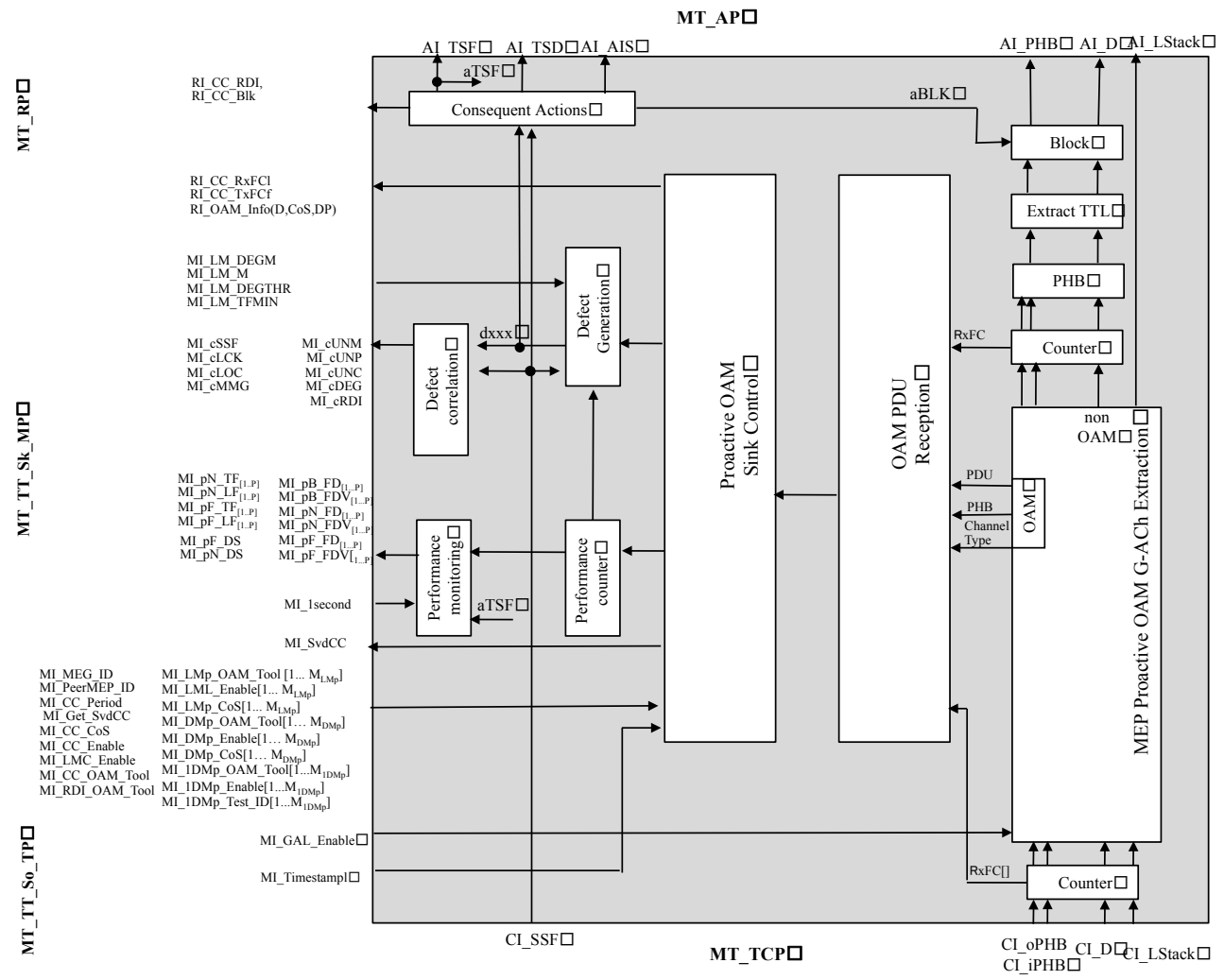

Figure 9-6/G.8121.1/Y.1381.1 – MT_TT_Sk process diagram

PHB: The CI_oPHB signal is assigned to the AI_PHB signal at the reference point MT_AP.

Note that the CI_iPHB signal is not used by any of the processes in the function.

Extract TTL: The Time To Live value is extracted from the outer shim header's TTL field within the MT_CI traffic unit

Block: When the aBlock consequent action is asserted, this process drops all traffic units arriving at its input.

Counter: It is used to count framepackets for proactive loss measurements. See 8.8.1.4 for the upper counter in Figure 9-3 and 8.8.4.7 for the lower counter in Figure 9-3

with CCM

G-Ach/GAL Extraction: See 8.1 in [ITU-T G.8121].

Pro-active OAM Sink Control: This process consists of following sub-processes as shown Figure 9-7. These details are in Clause 8.8.

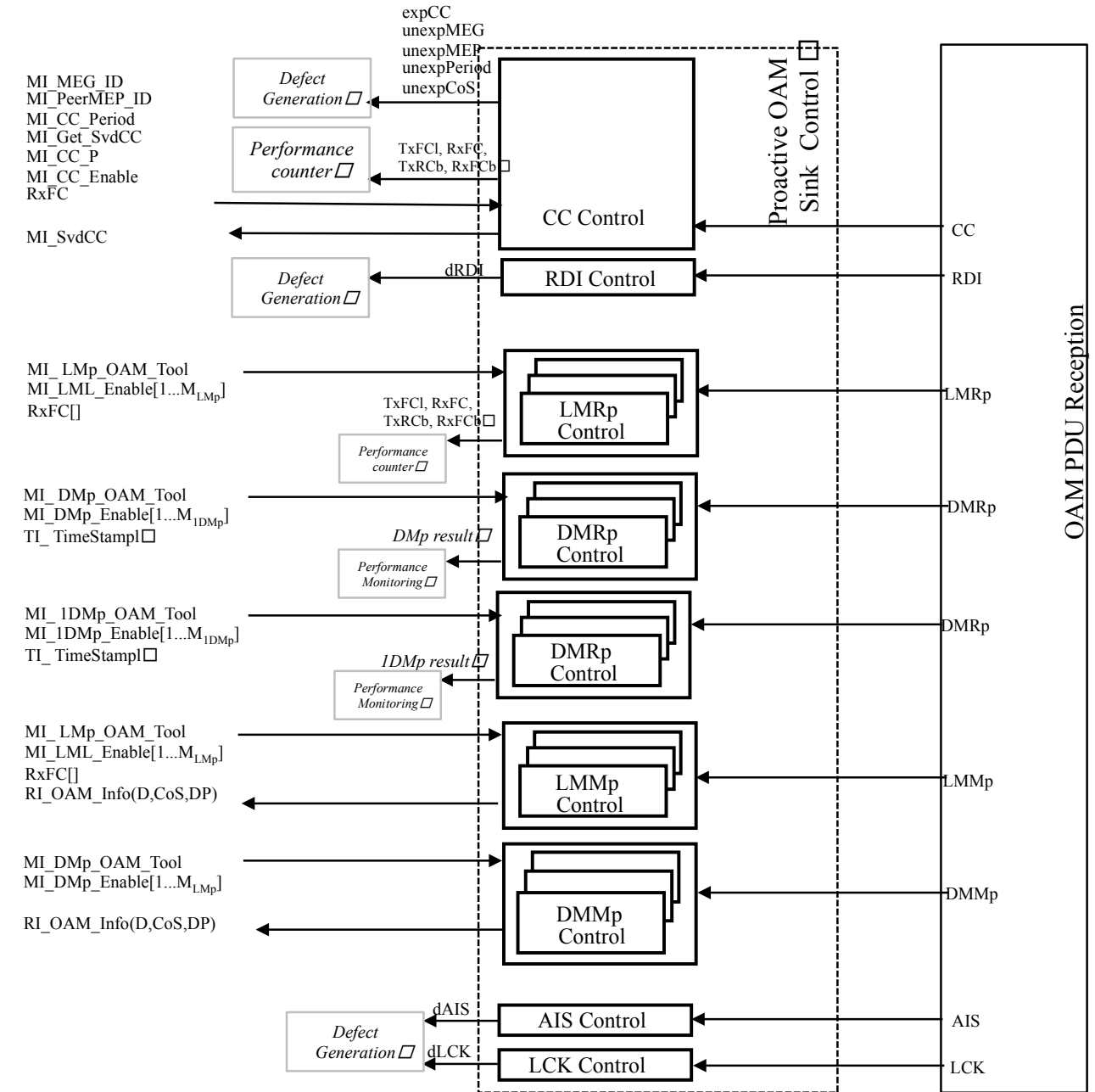

Figure 9-7/G.8121.1/Y.1381.1 – Pro-active OAM Sink Control Process

OAM PDU Receptions: See 8.8 in [ITU-T G.8121]

Defect Generation: This process raises and clears the defects as defined in clause 6.1 in in [ITU-T G.8121] that are dLOC, dMMG, dUNM, dDEG, dUNP, dUNPr, dRDI, dAIS, dLCK

• **Defects:**

This function detects dLOC[i], dUNL, dMMG, dUNM, dDEG, dUNP, dUNPr, dRDI[i], dAIS, dLCK.

• **Consequent actions:**

aBLK ← (dUNL or dMMG or dUNM)

Note that dUNP and dUNPr does not contribute to aBLK, because a mismatch of periodicity is not considered to be a security issue.

aTSF ← (dLOC and MI_CC_Enable) or (dAIS and not(MI_CC_Enable)) or (dLCK and not(MI_CC_Enable)) or dUNL or dMMG or dUNM or CI_SSF

aTSD ← dDEG and (not aTSF)

aAIS ← aTSF

aRDI ← aTSF

• **Defect correlations:**

cLOC[i] ← dLOC[i] and (not dAIS) and (not dLCK) and (not CI_SSF) and (MI_CC_Enable)

cUNL ← dUNL

cMMG ← dMMG

cUNM ← dUNM

cDEG[1] ← dDEG[1] and (not dAIS) and (not dLCK) and (not CI_SSF) and (not (dLOC[1..n] or dUNL or dMMG or dUNM)) and (MI_CC_Enable))

cUNP ← dUNP

cUNPr ← dUNPr

cRDI ← (dRDI[1..n]) and (MI_CC_Enable)

cSSF ← CI_SSF or dAIS

cLCK ← dLCK and (not dAIS)

• **Performance monitoring:**

pN_TF ← N_TF

pN_LF ← N_LF

pF_TF ← F_TF

pF_LF ← F_LF

pN_DS ← aTSF

pF_DS ← aRDI[1]

pB_FD ← B_FD

pB_FD V ← B_FD V

pF_FD ← F_FD
 pF_FD V ← F_FD V
 pN_FD ← N_FD
 pN_FD V ← N_FD V

9.3 Adaptation functions

9.3.1 MPLS-TP to MPLS-TP adaptation function (MT/MT_A)

This atomic functions are defined in clause 9.3.1 in G.8121. They use the OAM protocol specific AIS insertion process and LCK generation process as defined in clause 8.6.2 and 8.6.3.

9.4 MT Diagnostic Function

9.4.1 MT Diagnostic Trail Termination Functions for MEPs (MTDe)

The bidirectional MTDe Frail Termination (MTDe_TT) function is performed by a co-located pair of MTDe flow termination source (MTDe_TT_So) and sink (MTDe_TT_Sk) functions as shown in Figure 9-8.

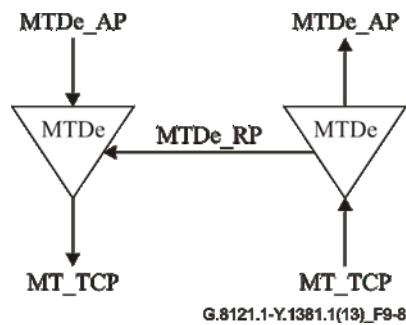

Figure 9-8/G.8121.1/Y.1381.1 – MTDe_TT

9.4.1.1 MT Diagnostic Trail Termination Source Function for MEPs (MTDe_TT_So)

Symbol

The MTDe_TT_So function symbol is shown in Figure 9-9.

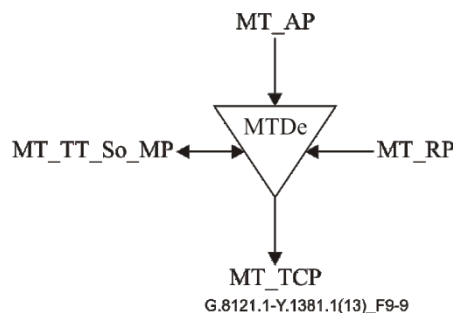

Figure 9-9/G.8121.1/Y.1381.1 – MTDe_TT_So symbol

Interfaces

Table 9-3/G.8121.1/Y.1381.1 – MTDe_TT_So interfaces

Input(s)	Output(s)
<p>MTDe_AP: MTDe_AI_D MTDe_AI_oPHB MTDe_AI_iPHB MTDe_AI_LStack</p> <p>MTDe_TT_RP: MTDe_RI_LMRo(TxFCf,RxFCf,TxFCb,RxFCI,CoS) MTDe_RI_DMRo(TxTimeStampf,RxTimeStampf, TxTimeStampb,RxTimeb,CoS) MTDe_RI_LMMo(D, CoS, DP) MTDe_RI_DMMo(D, CoS, DP) MTDe_RI_CVM(D, CoS, DP) <u>MTDe_RI_CVR(τTLV, TID)</u></p> <p>MTDe_TT_So_MP: MTDe_TT_So_MI_GAL_Enable MTDe_TT_So_MI_TTLVALUE MTDe_TT_So_MI_MEP_ID MTDe_TT_So_MI_CV_OAM_Tool MTDe_TT_So_MI_CV_Series (Target MEP/MIP ID,CoS,N,Length,Period) MTDe_TT_So_MI_CV_Test(CoS, Pattern, Length,Period)</p> <p>MTDe_TT_So_MI_CV_Terminate</p> <p>MTDe_TT_So_MI_1TH_OAM_Tool MTDe_TT_So_MI_1TH_Start(CoS, Pattern, Length,Period) MTDe_TT_So_MI_1TH_Terminate</p> <p>MTDe_TT_So_MI_LMo_OAM_Tool[1...M_{LMo}] MTDe_TT_So_MI_LMo_Start(CoS,Period) [1...M_{LMo}] <u>MTDe_TT_So_MI_LMo_Intermediate_Request[1...M_{LMo}]</u> MTDe_FT_So_MI_LMo_Terminate[1...M_{LMo}]</p> <p>MTDe_TT_So_MI_DMo_OAM_Tool[1...M_{DMo}] MTDe_TT_So_MI_DMo_Start (CoS, Length,Period)[1...M_{DMo}] <u>MTDe_TT_So_MI_DMo_Intermediate_Request[1...M_{DMo}]</u>] MTDe_TT_So_MI_DMo_Terminate[1...M_{DMo}]</p> <p>MTDe_TT_So_MI_1DMo_OAM_Tool[1...M_{1DMo}] MTDe_TT_So_MI_1DMo_Start (CoS, Length,Period)[1...M_{1DMo}] MTDe_TT_So_MI_1DMo_Terminate[1...M_{1DMo}]</p>	<p>MT_TCP: MT_CI_D MT_CI_oPHB MT_CI_iPHB MT_CI_LStack</p> <p>MTDe_TT_So_MP: MTDe_TT_So_MI_CV_Series_Result(REC,ERR,OO) MTDe_TT_So_MI_CV_Test_Result(Sent, REC, REC,ERR,OO) MTDe_TT_So_MI_1TH_Result(Sent) MTDe_TT_So_MI_LMo_Result(N_TF,N_LF,F_TF,F _LF)[1...M_{LMo}] MTDe_TT_So_MI_DMo_Result(count,B_FD[],F_FD [],N_FD[])[1...M_{DMo}]</p>

MTDe_TT_So_TP: MTDe_TT_So_TI_TimeStampI	
---	--

Processes

The processes associated with the MTDe_TT_So function are as depicted in Figure 9-10.

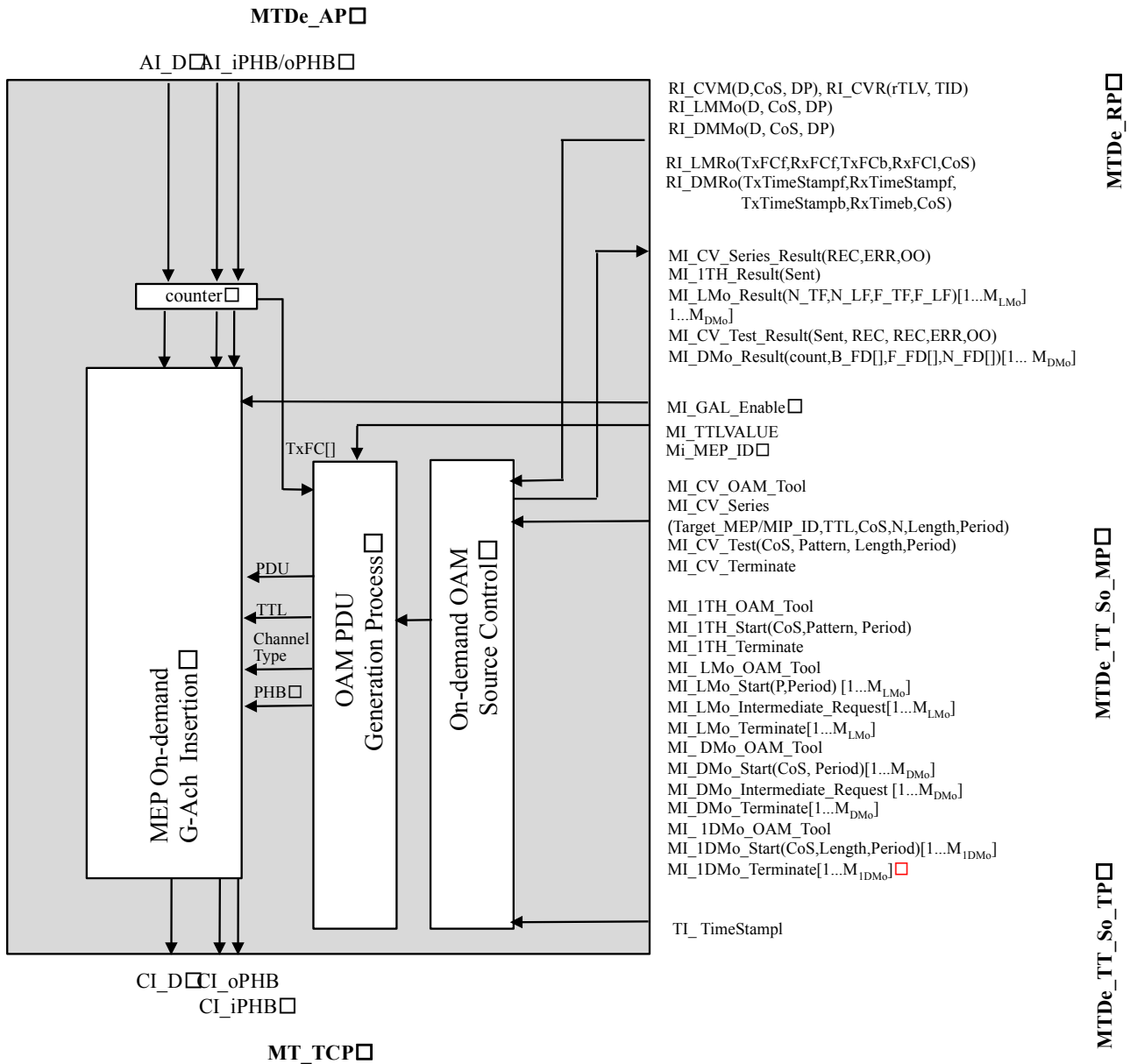

Figure 9-10/G.8121.1/Y.1381.1 – MTDe_TT_So Process

G-Ach/GAL Insertion: See 8.1 in [ITU-T G.8121].

On-demand OAM Source Control:

This process consists of following sub-processes, in conjunction with OAM PDU Generation Process, as shown Figure 9-11. These details are in clause 8.8/G.8121.1

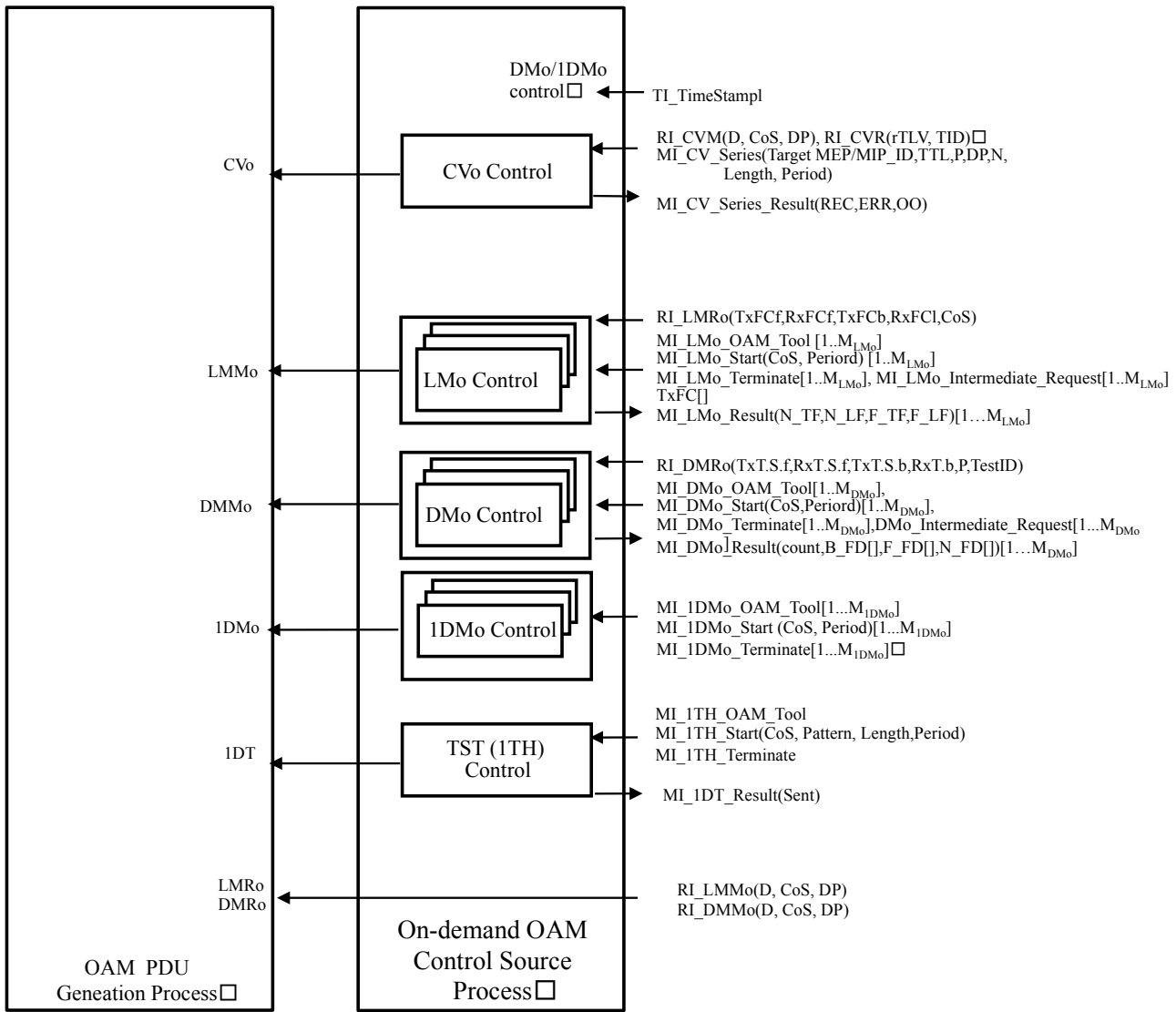

Figure 9-11/G.8121.1/Y.1381.1 – On-demand OAM Source Control Process

On-demand OAM PDU Generation Process: See 8.8 in [ITU-T G.8121]

Counter-Process: See 8.8.5.7 in [ITU-T G.8121.1]

Defects None.

Consequent actions None.

Defect correlations None.

Performance monitoring None.

9.4.1.2 MT Diagnostic Trail Termination Sink Function for MEPs (MTDe_TT_Sk)

Symbol

The MTDe_TT_Sk function symbol is shown in Figure 9-12.

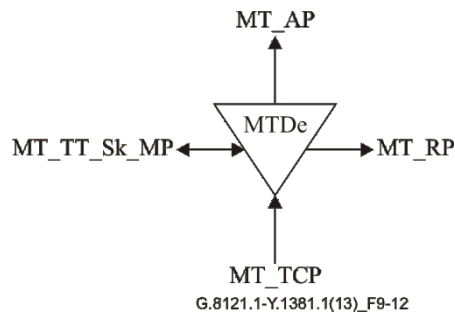

Figure 9-12/G.8121.1/Y.1381.1 – MTDe_TT_Sk symbol

Interfaces

Table 9-4/G.8121.1/Y.1381.1 – MTDe_TT_Sk interfaces

Input(s)	Output(s)
MT_TCP: MT_CI_D MT_CI_iPHB MT_CI_oPHB MT_CI_LStack	MTDe_AP: <u>9.4.1.2.1.1.1.1.1</u> MTDe_AI_D MTDe_AI_oPHB MTDe_AI_iPHB MTDe_AI_LStack
MT_RP: <u>MTDe_RI_CVR(rTLV, TID)</u>	MTDe_RP: MTDe_RI_CVM(D, CoS, DP) <u>MTDe_RI_CVR(rTLV, TID, CoS, DP)</u>
MTDe_TT_Sk_MP: MTDe_TT_Sk_MI_GAL_Enable MTDe_TT_Sk_MI_MEP_ID MTDe_TT_Sk_MI_CV_OAM_Tool MTDe_TT_Sk_MI_1TH_OAM_Tool MTDe_TT_Sk_MI_1TH_Start(Pattern, Length, Period) MTDe_TT_Sk_MI_1TH_Terminate MTDe_TT_Sk_MI_LMo_OAM_Tool[1...M _{LMo}] MTDe_TT_Sk_MI_DMo_OAM_Tool[1...M _{DMo}] MTDe_TT_Sk_MI_1DMo_OAM_Tool[1...M _{1DMo}] MTDe_TT_Sk_MI_1DMo_Start(<u>CoS</u>)[1...M _{1DMo}] <u>MTDe_TT_Sk_MI_1DMo_Intermediate_Request[1</u> <u>...M_{LMo}]</u> MTDe_TT_Sk_MI_1DMo_Terminate[1...M _{1DMo}]	MTDe_RI_LMMo(D, CoS, DP) MTDE_RI_DMMo(D, CoS, DP) MTDe_RI_LMRo(TxFcF,RxFcF,TxFcB,RxFcI,Co S) MTDe_RI_DMRo(TxTimeStampf,RxTimeStampf, TxTimeStampb,RxTimeb,CoS,TestID) MTDe_TT_Sk_MP: MTDe_TT_Sk_MI_1TH_Result(REC,CRC,BER,O O) MTDe_TT_Sk_MI_1DMo_Result(count,N_FD[])[1 ...M _{DMo}]
MTDe_TP: MTDe_TT_Sk_TI_TimeStampI	

Processes

The processes associated with the MTDe_TT_Sk function are as depicted in Figure 9-13.

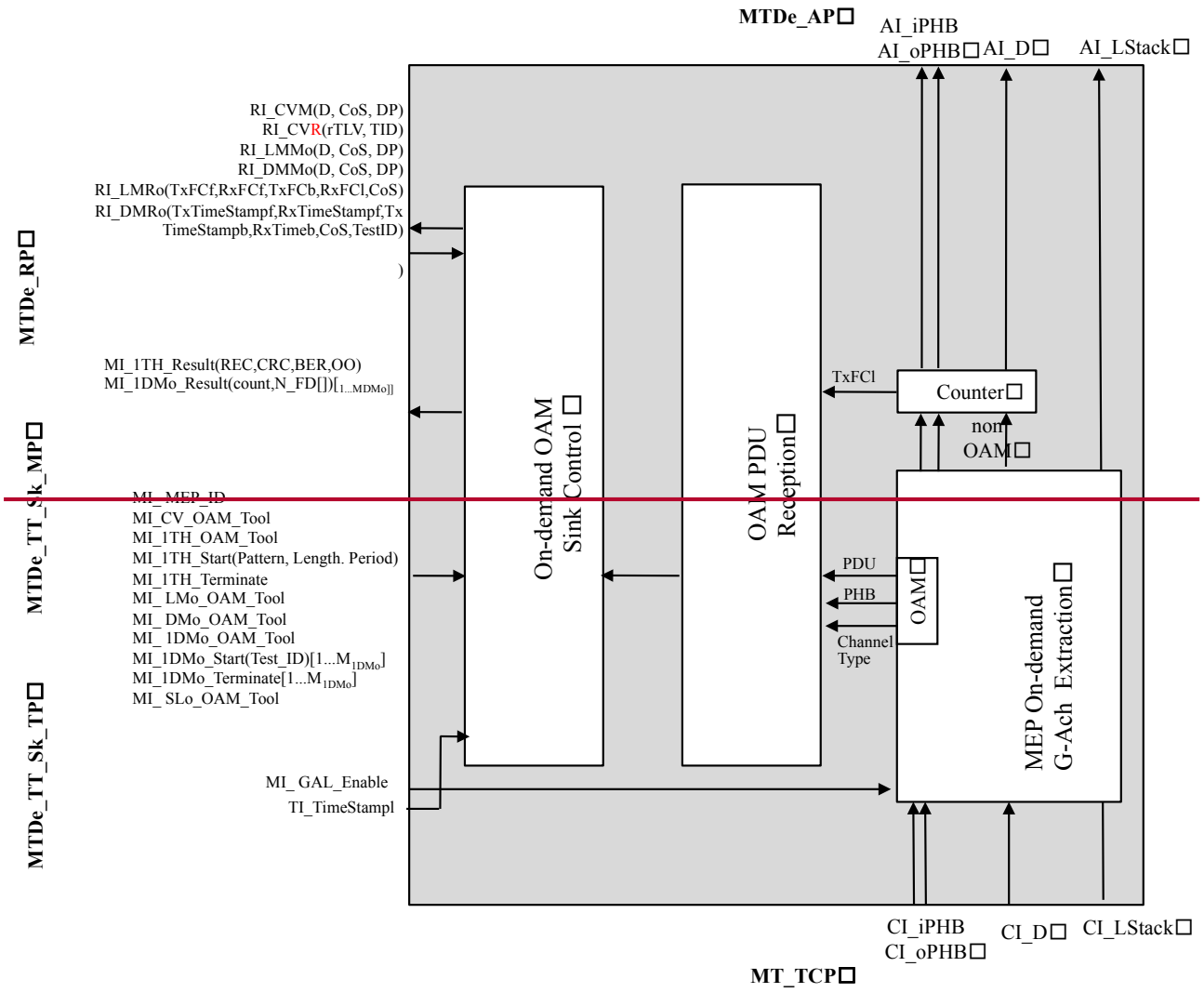

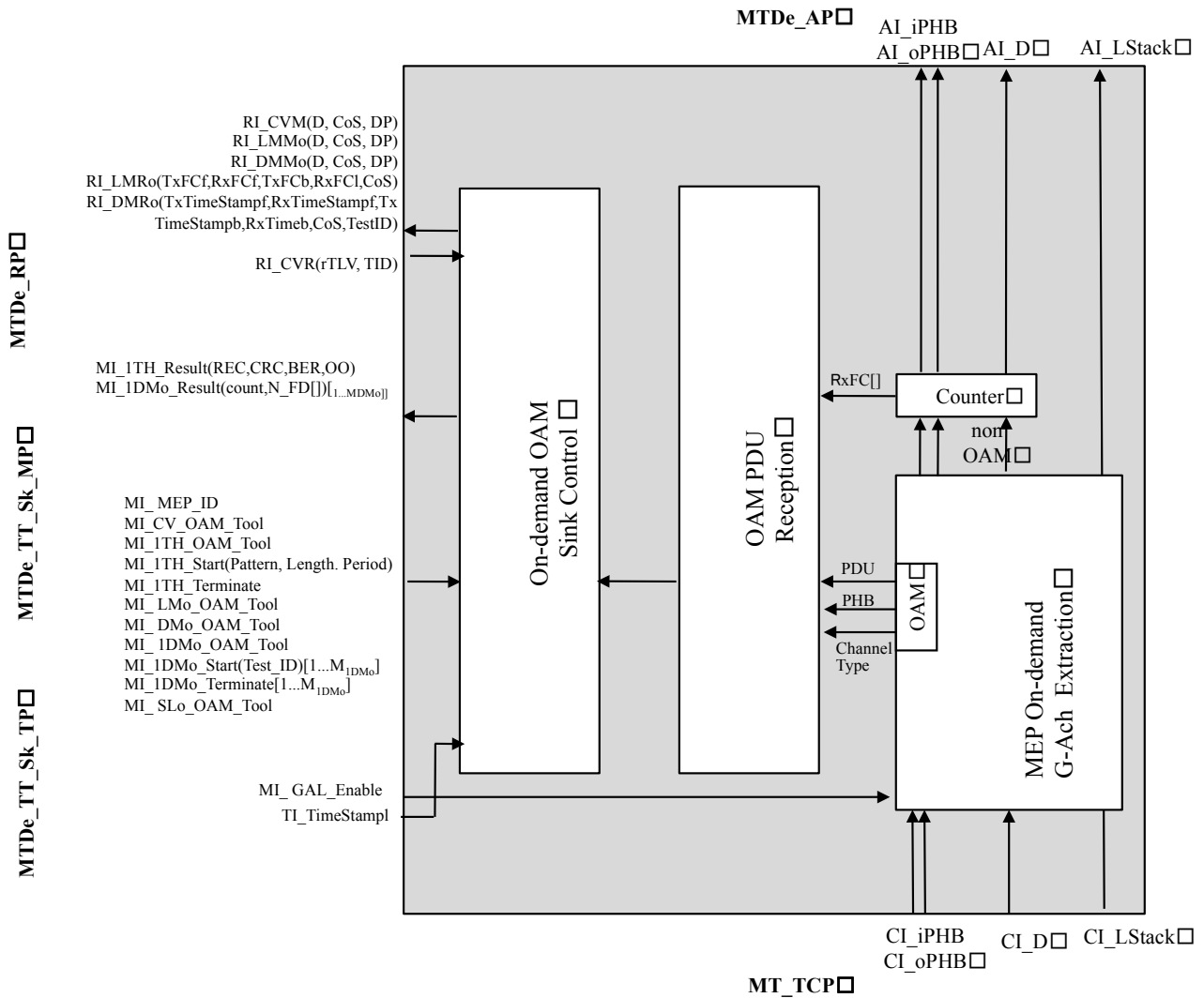

Figure 9-13/G.8121.1/Y.1381.1 – MTDe_TT_Sk Process

G-Ach/GAL Extraction: See 8.1 in [ITU-T G.8121].

On-demand OAM PDU Reception : See 8.8 in [ITU-T G.8121]

On-demand OAM Sink Control : This process consists of following sub-processes, in conjunction with OAM PDU Generation Process, as shown Figure 9-13. These details are in Clause 8.8.

Counter: See 8.8.5.7 in [ITU-T G.8121.1]

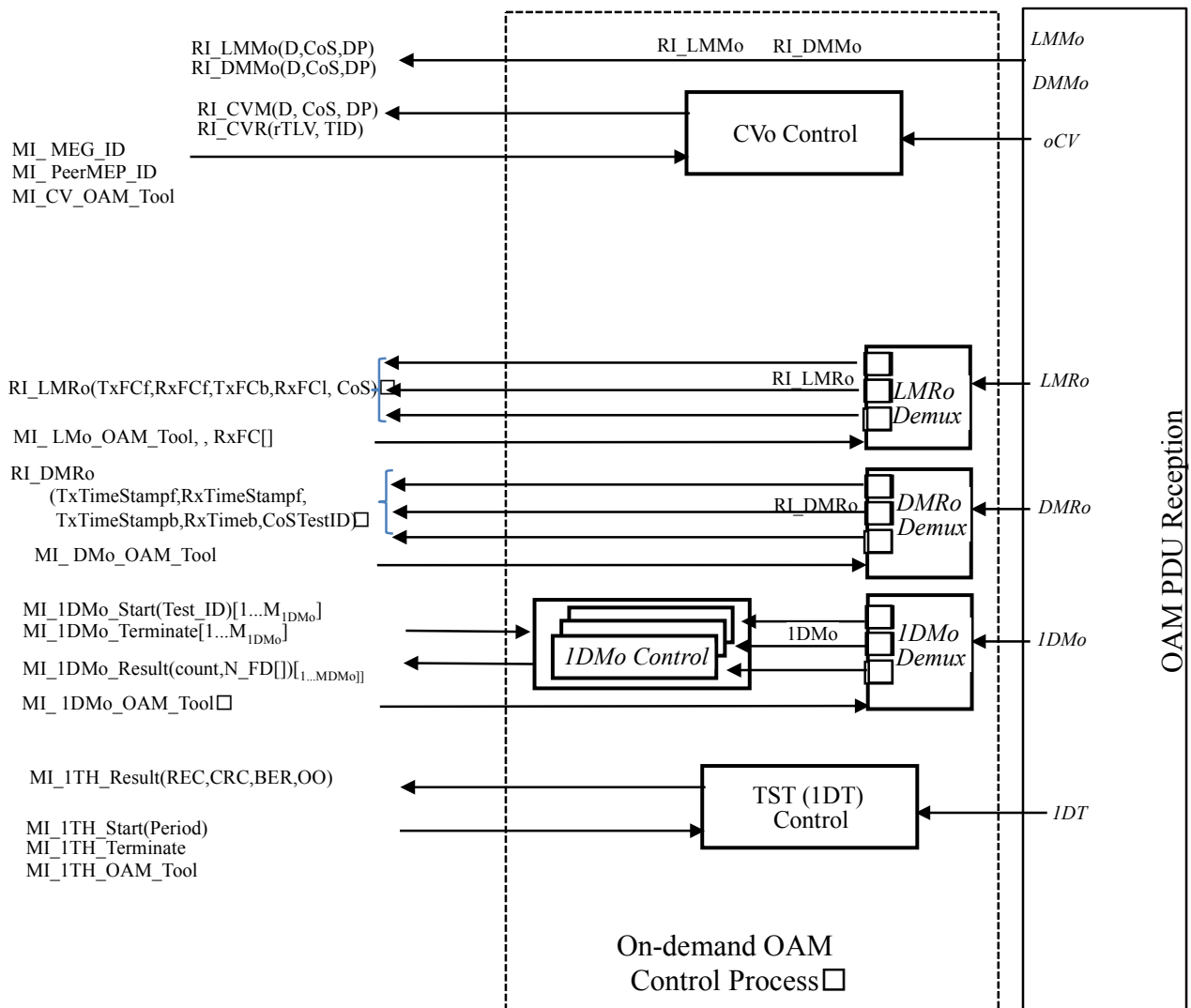

Figure 9-14/G.8121.1/Y.1381.1 – On-Demand OAM Sink Control Process

Defects	None
Consequent actions	None
Defect correlations	None
Performance monitoring	None

9.4.2 MT Diagnostic Trail Termination Functions for MIPs

9.4.2.1 MT Diagnostic Trail Termination Functions for MIPs

The MTDi/MT adaptation function is an empty function; it is included to satisfy the modelling rules.

The bidirectional MTD/MT adaptation function is performed by a co-located pair of MTDi/MT adaptation source (MTDi/MT_A_So) and sink (MTDi/MT_A_Sk) functions.

9.4.2.1.1 MT Diagnostic Trail Termination Source Function for MIPs (MTDi_TT_So)

Symbol

The MTDi_TT_So function symbol is shown in Figure 9-15.

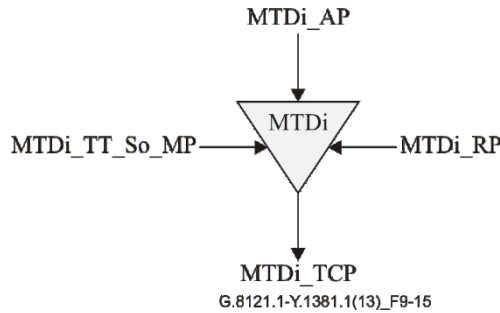

Figure 9-15/G.8121.1/Y.1381.1 – MTDi_TT_So symbol

Interfaces

Table 9-5/G.8121.1/Y.1381.1 – MTDi_TT_So interfaces

Inputs	Outputs
<p>MTDi_AP MT_AI_D MT_AI_iPHB MT_AI_oPHB MT_AI_Lstack</p> <p>MTDi_RP MTDi_RI_CV_Info (D, CoS, DP)</p> <p>MTDi_TT_So_MP MTDi_TT_So_MI_GAL_Enable MTDi_TT_So_MI_TTLVALUE MTDi_TT_So_MI_MIP_ID MTDi_TT_So_MI_CV_OAM_Tool</p>	<p>MTDi_TCP MT_CI_D, MT_CI_iPHB, MT_CI_oPHB, MT_CI_LStack</p>

Processes

The processes associated with the MTDi_TT_So function are as depicted in Figure 9-16

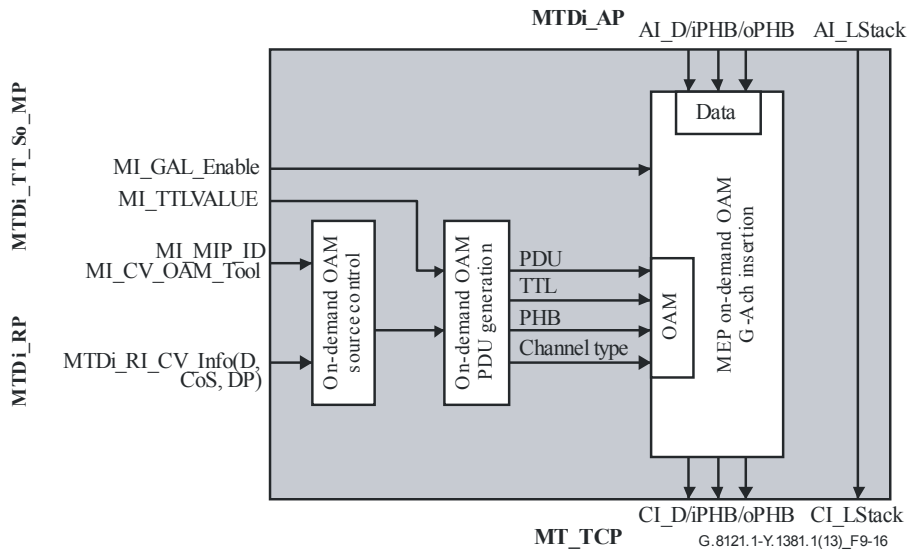

Figure 9-16/G.8121.1/Y.1381.1 – MTDi_TT_So Process

MIP OAM insertion: See clause 9.4.2.1.1 in [ITU-T G.8121]

On-demand OAM PDU Generation: See clause 9.4.2.1.1 in [ITU-T G.8121]

On-demand OAM Source Control: This process consists of oCV and RT sub-processes. These details are in 8.8/G.8121.1.

Defects None.

Consequent actions None.

Defect correlations None.

Performance monitoring None.

9.4.2.1.2 MT Diagnostic Trail Termination Sink Function for MIPs (MTDi_TT_Sk)

Symbol

The MTDi_TT_Sk function symbol is shown in Figure 9-17.

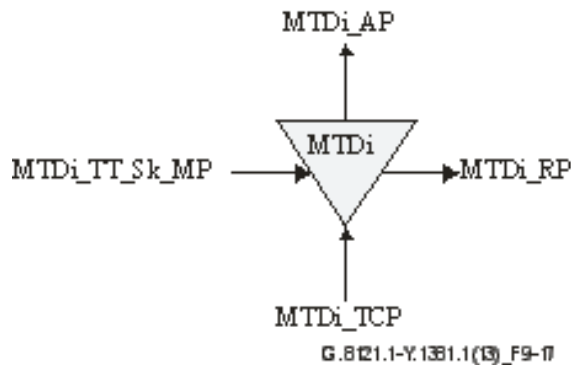

Figure 9-17/G.8121.1/Y.1381.1 – MTDi_TT_Sk symbol

Interfaces

Table 9-6/G.8121.1/Y.1381.1 – MTDi_TT_Sk interfaces

Inputs	Outputs
MTDi_TCP MT_CI_D MT_CI_iPHB MT_CI_oPHB MT_CI_LStack MTDi_TT_Sk_MP MTDi_TT_Sk_MI_GAL_Enable MTDi_TT_Sk_MI_MIP_ID MTDi_TT_Sk_MI_CV_OAM_Tool	MTDi_AP MT_AI_D MT_AI_iPHB MT_AI_oPHB MT_AI_LStack MTDi_RP MTDi_RI_CV_Info (D, CoS, DP)

Processes

The processes associated with the MTDi_TT_So function are as depicted in Figure 9-18

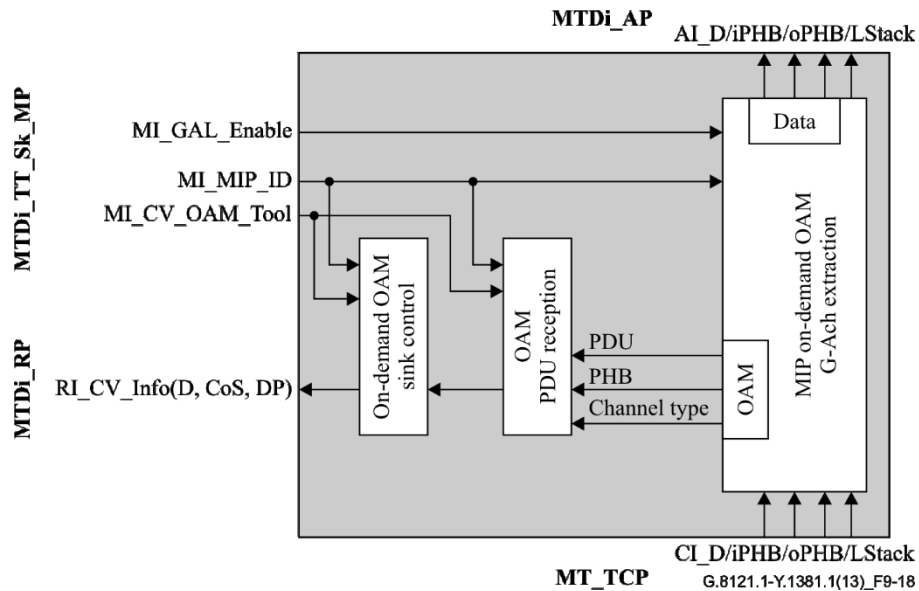

Figure 9-18/G.8121.1/Y.1381.1 – MTDi_TT_Sk Process

MIP OAM extraction: See clause 9.4.2.1.2 in [ITU-T G.8121]

On-demand OAM PDU Reception : See clause 9.4.2.1.2 in [ITU-T G.8121]

On-demand OAM Sink Control:

This process consists of oCV sub-processes. These details are in Clause 8.8.

Defects	None.
Consequent actions	None.
Defect correlations	None.
Performance monitoring	None.

9.4.2.2 MTDi to MT Adaptation functions (MTDi/MT_A)

See clause 9.4.2.2 in [ITU-T G.8121].

10 MPLS-TP to Non-MPLS-TP client adaptation functions

This atomic functions are defined in clause 10 in [ITU-T G.8121].

11 Non-MPLS-TP Server to MPLS-TP adaptation functions

These atomic functions are defined in clause 11 in [ITU-T G.8121]. They use the OAM protocol specific AIS insertion process and LCK generation process as defined in clause 8.6.2 and 8.6.3.
