

---

**Question(s):** 10, 14/15

15-26 February 2016

**TD****Source:** Editor G.8121/Y.1381**Title:** Draft revised Recommendation ITU-T G.8121/Y.1381 (for Consent, 26 February 2016)

---

**Abstract**

This document provides the draft revised G.8121/Y.1381 (for consent, 26 February 2016).

**Summary of major updates from version 2 (G.8121 (2013))**

- To support linear protection as in G.8131, defects for linear protection, APS insert/extract processes, MT\_C, and MT/MT Adaptation functions are updated.
- Due to the update APS insert/extract processes in clause 8, APS processes in Srv/MT\_A are removed
- Appendix III has been removed due to the maturity of G.8131.
- Updated some description for dFOP in align with G.8131 as well as other transport technologies
- Added the texts to clause 8.8.4 (LMp) and 8.8.5 (LMo) that clarify direct LM, synthetic loss measurement (SLM), and inferred loss measurement
- Added intermediate request to on-demand loss measurement in clause 9.4.1.1 (MTDe\_TT)
- Added MI\_1SLp\_\* and MI\_1LM\_Enable in clause 9.2.1 (MT\_TT)
- Fixed LStack behaviour in some atomic functions in clause 9
- Added new subclause 9.5 "MPLS-TP MEP and MIP fucntions"
- Fixed some incorrect diagrams (including SDL diagrams)

---

**Contact:** Yuji Tochio  
Fujitsu  
Japan

Tel: +81-44-754-8829  
Email: [tochio@jp.fujitsu.com](mailto:tochio@jp.fujitsu.com)

<b>Attention:</b> This is not a publication made available to the public, but <b>an internal ITU-T Document</b> intended only for use by the Member States of ITU, by ITU-T Sector Members and Associates, and their respective staff and collaborators in their ITU related work. It shall not be made available to, and used by, any other persons or entities without the prior written consent of ITU-T.
--

## **Draft revised Recommendation ITU-T G.8121/Y.1381**

### **Characteristics of MPLS-TP equipment functional blocks**

#### **Summary**

Recommendation ITU-T G.8121/Y.1381 specifies both the functional components and the methodology that should be used in order to specify MPLS-TP layer network functionality of network elements; it does not specify individual MPLS-TP network equipment as such.

#### **Keywords**

Atomic functions, equipment functional blocks, MPLS-TP layer network, MPLS-TP.

## Draft revised Recommendation ITU-T G.8121/Y.1381

### Characteristics of MPLS-TP equipment functional blocks<sup>1</sup>

#### 1 Scope

This Recommendation describes both the functional components and the methodology that should be used in order to describe MPLS-TP layer network functionality of network elements; it does not describe individual MPLS-TP network equipment as such.

This Recommendation provides a representation of the MPLS-TP technology using the methodologies that have been used for other transport technologies (e.g. SDH, OTN and Ethernet).<sup>2</sup>

This Recommendation forms part of a suite of Recommendations covering the full functionality of network equipment. These Recommendations are [ITU-T G.806], [ITU-T G.798], [ITU-T G.783], [ITU-T G.705] and [ITU-T G.8021/Y.1341]. This Recommendation also follows the principles defined in [ITU-T G.805].

These Recommendations specify a library of basic building blocks and a set of rules by which they may be combined in order to describe digital transmission equipment. The library comprises the functional building blocks needed to specify completely the generic functional structure of the MPLS-TP layer network. In order to be compliant with this Recommendation, equipment needs to be describable as an interconnection of a subset of these functional blocks contained within this Recommendation. The interconnections of these blocks should obey the combination rules given.

---

<sup>1</sup> Cisco Systems has expressed concerns that in the event of a difference between this ITU-T Recommendation and any of the normatively referenced IETF RFCs, interoperability issues may arise. To prevent interoperability issues, the behavior defined in the IETF RFCs must be maintained, and any such differences must be resolved in coordination with the IETF in a timely manner.

France Telecom Orange has expressed concerns that in the event of a difference between this ITU-T Recommendation and any of the normatively referenced IETF RFCs, interoperability issues may arise. To prevent interoperability issues, the behavior defined in the IETF RFCs must be maintained, and any such differences must be resolved in coordination with the IETF in a timely manner.

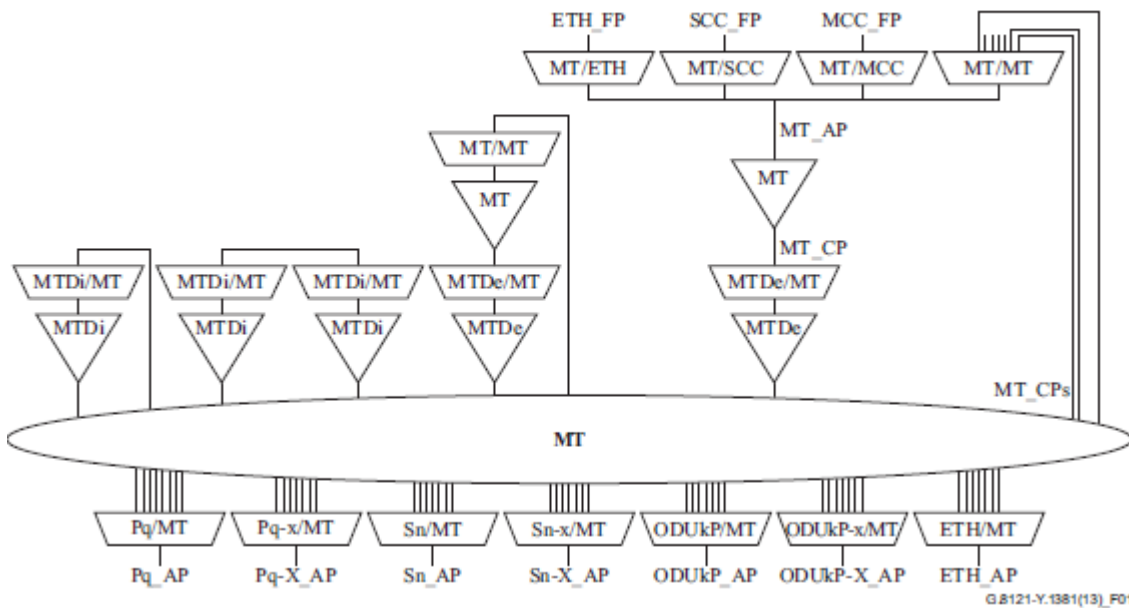
Nokia Siemens Networks (NSN) is concerned that, in the event of a difference between this ITU-T Recommendation and any of the IETF RFCs to which it makes normative reference, interoperability issues may arise. G.8121 contains no guidance on how to resolve such a situation. NSN believes that in the case of such an event differences should be resolved in coordination with the IETF and that the behavior specified in the RFC(s) must be maintained.

Verizon Communications has expressed concerns that in the event of a difference between this ITU-T Recommendation and the behavior defined in the normatively referenced IETF RFCs, interoperability issues may arise. There is no guidance in this ITU-T Recommendation that describes how to address differences in behavior between the Recommendation and the normatively referenced IETF RFCs. Verizon Communications feels that any difference should be resolved in coordination with the IETF in a timely manner and until the issue is resolved, the behavior defined in the IETF RFCs should be maintained.

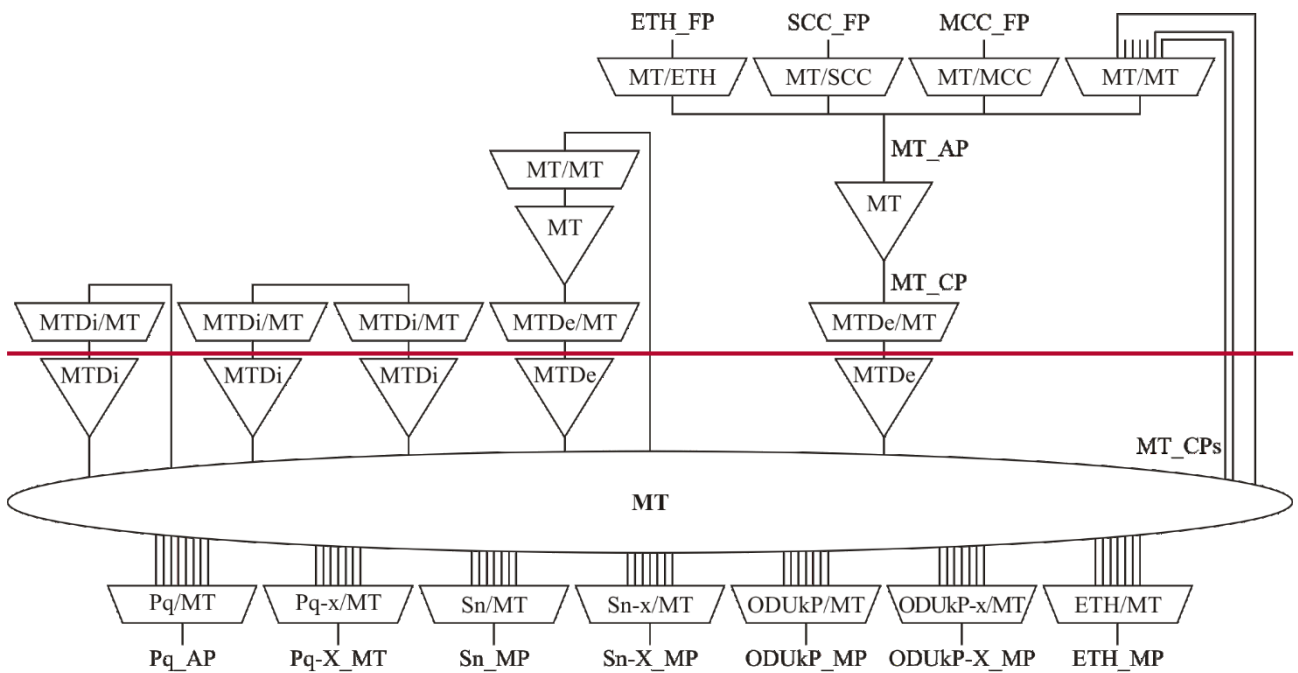
<sup>2</sup> This ITU-T Recommendation is intended to be aligned with the IETF MPLS RFCs normatively referenced by this Recommendation.

Not every atomic function defined in this Recommendation is required for every application. Different subsets of atomic functions may be assembled in different ways according to the combination rules given in this Recommendation to provide a variety of different capabilities. Network operators and equipment suppliers may choose which functions must be implemented for each application.

Figure 1 presents the set of atomic functions associated with the traffic signal transport. The functions are based on the functional architecture as described in [ITU-T G.8110.1]. It is noted that this recommendation only defines Ethernet for the client of MPLS-TP as MT/ETH adaptation function.



G.8121-Y.1381(13)\_F01



G.8121-Y.1381(13)\_F1-1

**Figure 1/G.8121/Y.1381 – MPLS-TP atomic functions**

[Ed note: The bottom line of “\*\_MP” should be “\*\_AP”. It also applies to Fig 9-0]

## 2 References

The following ITU-T Recommendations and other references contain provisions which, through reference in this text, constitute provisions of this Recommendation. At the time of publication, the editions indicated were valid. All Recommendations and other references are subject to revision; users of this Recommendation are therefore encouraged to investigate the possibility of applying the most recent edition of the Recommendations and other references listed below. A list of the currently valid ITU-T Recommendations is regularly published. The reference to a document within this Recommendation does not give it, as a stand-alone document, the status of a Recommendation.

- [ITU-T G.704] Recommendation ITU-T G.704 (1998), *Synchronous frame structures used at 1544, 6312, 2048, 8448 and 44 736 kbit/s hierarchical levels*
- [ITU-T G.705] Recommendation ITU-T G.705 (2000), *Characteristics of plesiochronous digital hierarchy (PDH) equipment functional blocks.*
- [ITU-T G.707] Recommendation ITU-T G.707/Y.1322 (2003), *Network node interface for the synchronous digital hierarchy (SDH).*
- [ITU-T G.709] Recommendation ITU-T G.709/Y.1331 (2012), *Interfaces for the Optical Transport Network (OTN).*
- [ITU-T G.780] Recommendation ITU-T G.780/Y.1351 (2004), *Terms and definitions for synchronous digital hierarchy (SDH) networks.*
- [ITU-T G.783] Recommendation ITU-T G.783 (2006), *Characteristics of synchronous digital hierarchy (SDH) equipment functional blocks.*
- [ITU-T G.798] Recommendation ITU-T G.798 (2012), *Characteristics of optical transport network hierarchy equipment functional blocks*
- [ITU-T G.805] Recommendation ITU-T G.805 (2000), *Generic functional architecture of transport networks.*
- [ITU-T G.806] Recommendation ITU-T G.806 (2012), *Characteristics of transport equipment – Description methodology and generic functionality.*
- [ITU-T G.832] Recommendation ITU-T G.832 (1998), *Transport of SDH elements on PDH networks – Frame and multiplexing structures.*
- [ITU-T G.7041] Recommendation ITU-T G.7041/Y.1303 (2011), *Generic framing procedure (GFP).*
- [ITU-T G.7043] Recommendation ITU-T G.7043/Y.1343 (2004), *Virtual Concatenation of Plesiochronous Digital Hierarchy (PDH) signals.*
- [ITU-T G.7044] Recommendation ITU-T G.7044/Y.1344 (2011), *Hitless adjustment of ODUflex(GFP)*
- [ITU-T G.7712] Recommendation ITU-T G.7712/Y.1703 (2010), *Architecture and specification of data communication network*
- [ITU-T G.8021] Recommendation ITU-T G.8021/Y.1341 (2015), *Characteristics of Ethernet transport network equipment functional blocks.*
- [ITU-T G.8040] Recommendation ITU-T G.8040/Y.1340 (2005), *GFP frame mapping into Plesiochronous Digital Hierarchy (PDH)*

- [ITU-T G.8101] Recommendation ITU-T G.8101/Y.1355 (~~2013~~2015), *Terms and definitions for MPLS transport profile*.
- [ITU-T G.8110.1] Recommendation ITU-T G.8110.1/Y.1370.1 (2011), *Architecture of MPLS-TP (MPLS-TP) layer network*.
- [ITU-T G.8131] Recommendation ITU-T G.8131/Y.1382 (2014), *Linear protection switching for MPLS transport profile (MPLS-TP)*
- [ITU-T G.8251] Recommendation ITU-T G.8251 (2010), *The control of jitter and wander within the optical transport network (OTN)*.
- [ITU-T Y.1415] Recommendation ITU-T Y.1415 (2005), *Ethernet-MPLS network interworking – User plane interworking*.
- [IETF RFC 4448] IETF RFC 4448 (2006), *Encapsulation Methods for Transport of Ethernet over MPLS Networks*.
- [IETF RFC 4720] IETF RFC 4720 (2006), *Pseudowire Emulation Edge-to-Edge (PWE3) – Frame Check Sequence Retention*.
- [IETF RFC 5332] IETF RFC 5332 (2008), *MPLS Multicast Encapsulation*.
- [IETF RFC 5586] IETF RFC 5586 (2009), *MPLS Generic Associated Channel*.
- [IETF RFC 5718] IETF RFC 5718 (2010), *An Inband Data Communication Network For the MPLS Transport Profile*.
- [IETF RFC 6371] IETF RFC 6371 (2011), *Operations, Administration and Maintenance Framework for MPLS-based Transport Networks*.
- [IETF RFC 6374] IETF RFC 6374 (2011), *Packet Loss and Delay Measurement for MPLS Networks*. [YTI]
- [IETF RFC 6435] IETF RFC 6435 (2011), *MPLS Transport Profile Lock Instruct and Loopback Functions*, plus Errata 3429 (2013)

### 3 Definitions

#### 3.1 Terms defined elsewhere:

- 3.1.1 access point: [ITU-T G.805]
- 3.1.2 adapted information: [ITU-T G.805]
- 3.1.3 characteristic information: [ITU-T G.805]
- 3.1.4 client/server relationship: [ITU-T G.805]
- 3.1.5 connection: [ITU-T G.805]
- 3.1.6 connection point: [ITU-T G.805]
- 3.1.7 layer network : [ITU-T G.805]
- 3.1.8 matrix: [ITU-T G.805]
- 3.1.9 network: [ITU-T G.805]
- 3.1.10 network connection: [ITU-T G.805]
- 3.1.11 reference point: [ITU-T G.805]

- 3.1.12 subnetwork: [ITU-T G.805]
- 3.1.13 subnetwork connection: [ITU-T G.805]
- 3.1.14 termination connection point : [ITU-T G.805]
- 3.1.15 trail: [ITU-T G.805]
- 3.1.16 trail termination: [ITU-T G.805]
- 3.1.17 transport: [ITU-T G.805]
- 3.1.18 transport entity: [ITU-T G.805]
- 3.1.19 transport processing function: [ITU-T G.805]
- 3.1.20 unidirectional connection: [ITU-T G.805]
- 3.1.21 unidirectional trail: [ITU-T G.805]
- 3.1.22 label: [ITU-T G.8101]
- 3.1.23 label stack: [ITU-T G.8101]
- 3.1.2 MPLS label stack: [ITU-T G.8101]
- 3.1.24 label switched path: [ITU-T G.8101]
- 3.1.25 Bottom of Stack: [ITU-T G.8101]
- 3.1.26 Time To Live: [ITU-T G.8101]
- 3.1.27 Label value: [ITU-T G.8101]
- 3.1.28 Per-Hop Behaviour: [ITU-T G.8101]
- 3.1.29 Associated Channel Header: [ITU-T G.8101]
- 3.1.30 Generic Associated Channel: [ITU-T G.8101]
- 3.1.31 G-ACh Label: [ITU-T G.8101]
- 3.1.32 traffic class: [ITU-T G.8101]
- 3.1.33 Explicitly TC-encoded-PSC LSP: [ITU-T G.8101]
- 3.1.34 label inferred PHB scheduling class LSP: [ITU-T G.8101]

## 3.2 Terms defined elsewhere:

None

## 4 Abbreviations

This Recommendation uses the following abbreviations:

ACH	Associated Channel Header
AI	Adapted Information
AIS	Alarm indication signal
AP	Access Point
<a href="#">APC</a>	<a href="#">Automatic Protection Coordination</a>
APS	Automatic protection switching
<a href="#">APsb</a>	<a href="#">APS frame packet with incompatible "PT" APS frame with incompatible "B" bit value</a>
<a href="#">APSc</a>	<a href="#">APS packet with incompatible Capabilities TLV</a>

CC	Continuity Check
CC-V	Continuity Check and Connectivity Verification
CC/CV	Continuity Check or Connectivity Verification
CI	Characteristic Information
CII	Common Interworking Indicator
CoS	Class of Service
CP	Connection Point
CSF	Client Signal Fail
CV	Connectivity Verification
CW	Control Word
DM	Delay Measurement
DP	Drop Precedence
DT	Diagnostic Test
ECC	Embedded Communication Channel
EMF	Equipment Management Function
ETH	Ethernet MAC layer network
ETY	Ethernet PHY layer network
E-LSP	Explicitly TC-encoded-PSC LSP
FDI	Forward Defect Indication
FP	Flow Point
FTP	Flow termination point
G-ACh	Generic Associated Channel
GAL	G-ACh Label
GFP	Generic Framing Procedure
HAO	Hitless Adjustment of ODUflex
L-LSP	Label-Only-Inferred PSC LSP
LCAS	Link Capacity Adjustment Scheme
LCK	Locked
LKI	Lock Instruct
LKR	Lock Report
LM	Loss Measurement
LOS	Loss of Signal
LSP	Label Switched Path
LStack	Label Stack
MCC	Maintenance Communication Channel
MEG	Maintenance Entity Group (New)
MEP	Maintenance entity group (MEG) End Point
MIP	Maintenance entity group (MEG) Intermediate Point
MP	Management Point
MPLS	Multi-Protocol Label Switching
MPLS-TP	Multi-Protocol Label Switching - Transport Profile
MT	Multi-Protocol Label Switching - Transport Profile
MTDe	MPLS-TP MEP Diagnostic function
MTDi	MPLS-TP MIP Diagnostic function
OAM	Operation, Administration and Maintenance
PDU	Protocol Data Unit
PHB	Per Hop Behaviour
PW	Pseudowire
PSC	PHB Scheduling Class
RDI	Remote Defect Indication



RFC	IETF Request For Comments
RI	Remote Information
RP	Remote Point
RT	Route Trace
SCC	Signalling Communication Channel
SCCType	Signalling Communication Channel type
TCP	Termination Connection Point
TFP	Termination Flow Point
TH	Throughput
TTL	Time-To-Live
TTSI	Trail Termination Source Identifier
ODU	Optical Channel Data Unit
ODUk	Optical Channel Data Unit – order k
ODUk-Xv	Virtual concatenated Optical Channel Data Unit – order k
OPU	Optical Payload Unit
OPUk	Optical Payload Unit of level k
OPUk-Xv	Virtually concatenated Optical Payload Unit of level k
OTH	Optical Transport Hierarchy
P11s	1544 kbit/s PDH path layer with synchronous 125 µs frame structure according to [ITU-T G.704]
P12s	2048 kbit/s PDH path layer with synchronous 125 µs frame structure according to [ITU-T G.704]
P31s	34368 kbit/s PDH path layer with synchronous 125 µs frame structure according to [ITU-T G.832]
P32e	44 736 kbit/s PDH path layer with frame structure according to [ITU-T G.704]
PM	Performance Monitoring
PSI	Payload Structure Indication
PT	Payload Type
RES	Reserved overhead
SSF	Server Signal Fail
TC	Traffic Class
TLV	Type Length Value
TSD	Trail Signal Degrade
TSF	Trail Signal Fail
vcPT	virtual concatenation Payload Type
VcPLM	Virtual concatenation Payload Mismatch

## 5 Conventions

The diagrammatic convention for connection-oriented layer networks described in this Recommendation is that of [ITU-T G.805].

*[Note: (SP#7, LL) In clause 5 of the latest draft of G.8152 (wd28, Nuremberg, 2013), Compound functions for MEP and MIP are described as convention. However, it is better to transfer to G.8121.]*

## 6 Supervision

The generic supervision functions are defined in clause 6 of [ITU-T G.806]. Specific supervision functions for the MPLS-TP network are defined in this clause.

## 6.1 Defects

### 6.1.1 Summary of Entry/Exit conditions for defects

The defect Entry and Exit conditions are based on events. Occurrence or absence of specific events may raise or reset specific defects.

In the following:

Valid means a received value is *equal* to the value configured via the MI input interface(s).

Invalid means a received value is *not equal* to the value configured via the MI input interface(s).

The events defined for this Recommendation are summarized in Table 6-1 as a quick overview. Events, other than the protection switching events, are generated by processes in the MT\_TT\_Sk function as defined in clause 9.2. These processes define the exact conditions for these events; Table 6-1 only provides a quick overview.

**Table 6-1/ G.8121/Y.1381 – Overview of Events**

Event	Meaning
unexpMEG	Reception of a CC-V packet with an invalid MEG value.(Note 1) NOTE - Section 5.1.1 of [IETF RFC 6371] describes the conditions when a received CC-V packet is considered to have invalid MEG and MEP values. In case (1) a CC packet is received by a sink MEP monitoring the MEG for CC and CV functions, or (2) a CV packet is received by a sink MEP monitoring the MEG for CC-only function; the received CC-V packet is considered as having an invalid MEG value (thus triggering the unexpMEG event)
unexpMEP	Reception of a CV packet with an invalid MEP value, but with a valid MEG value.
unexpPeriod	Reception of a CC-V packet with an invalid Periodicity value, but with valid MEG and MEP values.
unexpCoS	Reception of a CC-V packet with an invalid TC value, but with valid MEG and MEP values.
expCC-V	Reception of a CC-V packet with valid MEG and MEP values.
RDI=x	Reception of a CC-V packet for the peer MEP with the RDI information indicate to x; where x=0 (remote defect clear) and x=1 (remote defect set).
LCK	Reception of a LCK packet. (Note 2)
AIS	Reception of an AIS packet.
BS	Bad Second, a second in which the Lost Frame Ratio exceeds the Bad Second Threshold (BS_THR).
CSF-LOS	Reception of a CSF packet that indicates Client Loss of Signal.
CSF-FDI	Reception of a CSF packet that indicates Client Forward Defect Indication.

CSF-RDI	Reception of a CSF packet that indicates Client Reverse Defect Indication.
expAPS	Reception of a valid APS packet. (Note3)
APSw	Reception of an APS packet from the working transport entity.
APSp	Reception of an APS packet with incompatible "PT" field value.
APSc	Reception of an APS packet with incompatible Capabilities TLV information.
APSr	Reception of an APS packet with incompatible "Data Path" value. <a href="#">(Note 4)</a>
<p>Note 1: According to [IETF RFC 6371], a CC-V packet is either a CC packet or a CV packet. A CV packet performs both CC and CV OAM functions. A CC packet performs only CC OAM function.</p> <p>Note 2: IETF uses this term LCK as LKR and LKI in [IETF RFC 6371]</p> <p>Note 3: For the term APS, [ITU-T G.8131] conventionally uses the term APC for the protocol of MPLS-TP linear protection.</p> <p><a href="#">Note 4: one way to detect this event is to detect that the transmitted "Data Path" and the received "Data Path" values differ, for example in case traffic switching occurs due to a local request.</a></p>	

The occurrence or absence of these events may detect or clear a defect. An overview of the conditions is given in Table 6-2. The notation "#event=x (K\*period)" is used to indicate the occurrence of x events within the period as specified between the brackets.

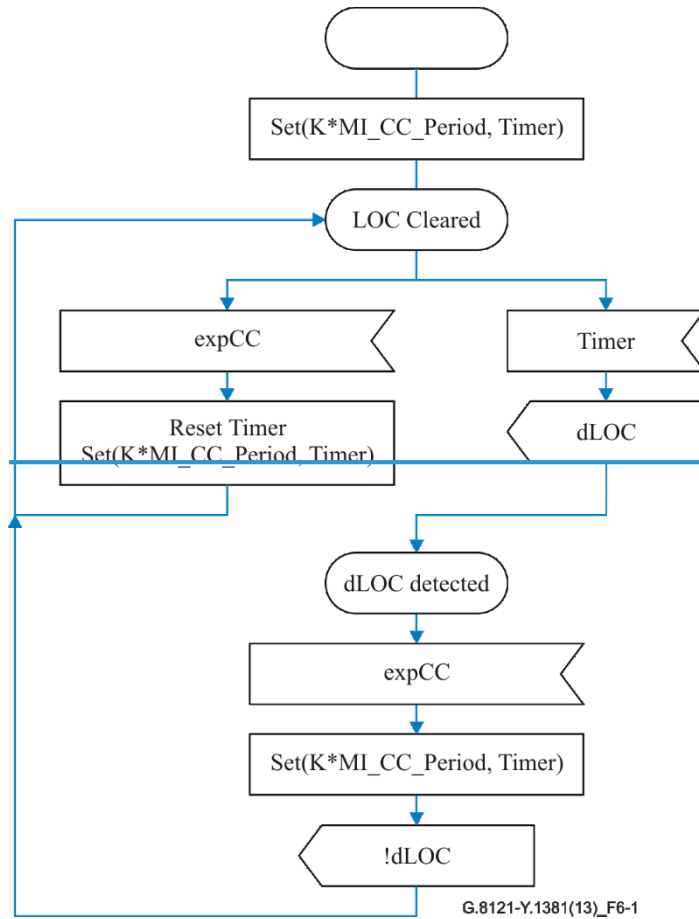
Table 6-2 gives a quick overview of the types of defects for MPLS-TP layer and the raising and clearing conditions for the these defects as described in [IETF RFC 6371];.

**Table 6-2/ G.8121/Y.1381 – Overview of Detection and Clearing Conditions**

<b>Defect</b>	<b>Defect Detection</b>	<b>Clearing Condition</b>
dLOC	#expCC-V==0 (K*CC_Period)	expCC-V
dUNC	unexpCoS	#unexpCoS==0 (K*CC-V_Period)
dMMG	unexpMEG	#unexpMEG==0 (K* CC-V_Period)
dUNM	unexpMEP	#unexpMEP==0 (K*CC-V_Period)
dUNP	unexpPeriod	#unexpPeriod==0 (K*CC-V_Period)
dRDI	RDI==1	RDI==0
dAIS	AIS	#AIS==0 (K*AIS_Period)
dLCK	LCK	#LCK==0 (K*LCK_Period)
dCSF-LOS	CSF-LOS	#CSF-LOS == 0 (K*CSF_Period or CSF-DCI)
dCSF-FDI	CSF-FDI	#CSF-FDI == 0 (K*CSF_Period or CSF-DCI)
dCSF-RDI	CSF-RDI	#CSF-RDI == 0 (K*CSF_Period or CSF-DCI)
dDEG	#BS==DEGM (DEGM*1second)	#BS==0 (M*1second)
dFOP-PMb	APSp	expAPS

dFOP-PMc	APSc	expAPS
dFOP-NR	APSr continues more than 50ms	expAPS
dFOP-CM	APSw	#APSw == 0 (K*normal APS Period)
dFOP-TO	#expAPS==0 (K * long APS interval)	expAPS

## **6.1.2 Continuity Supervision**



G.8121-Y.1381(13)\_F6-1

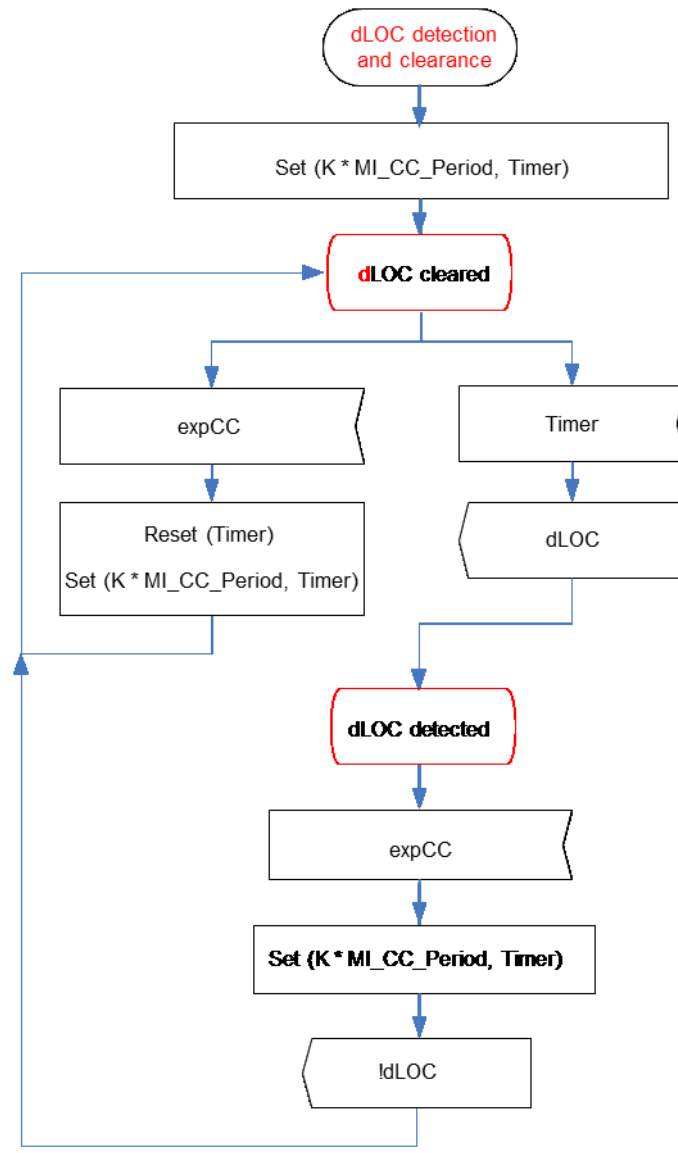


Figure 6-1/G.8121/Y.1381 – dLOC detection and clearance process

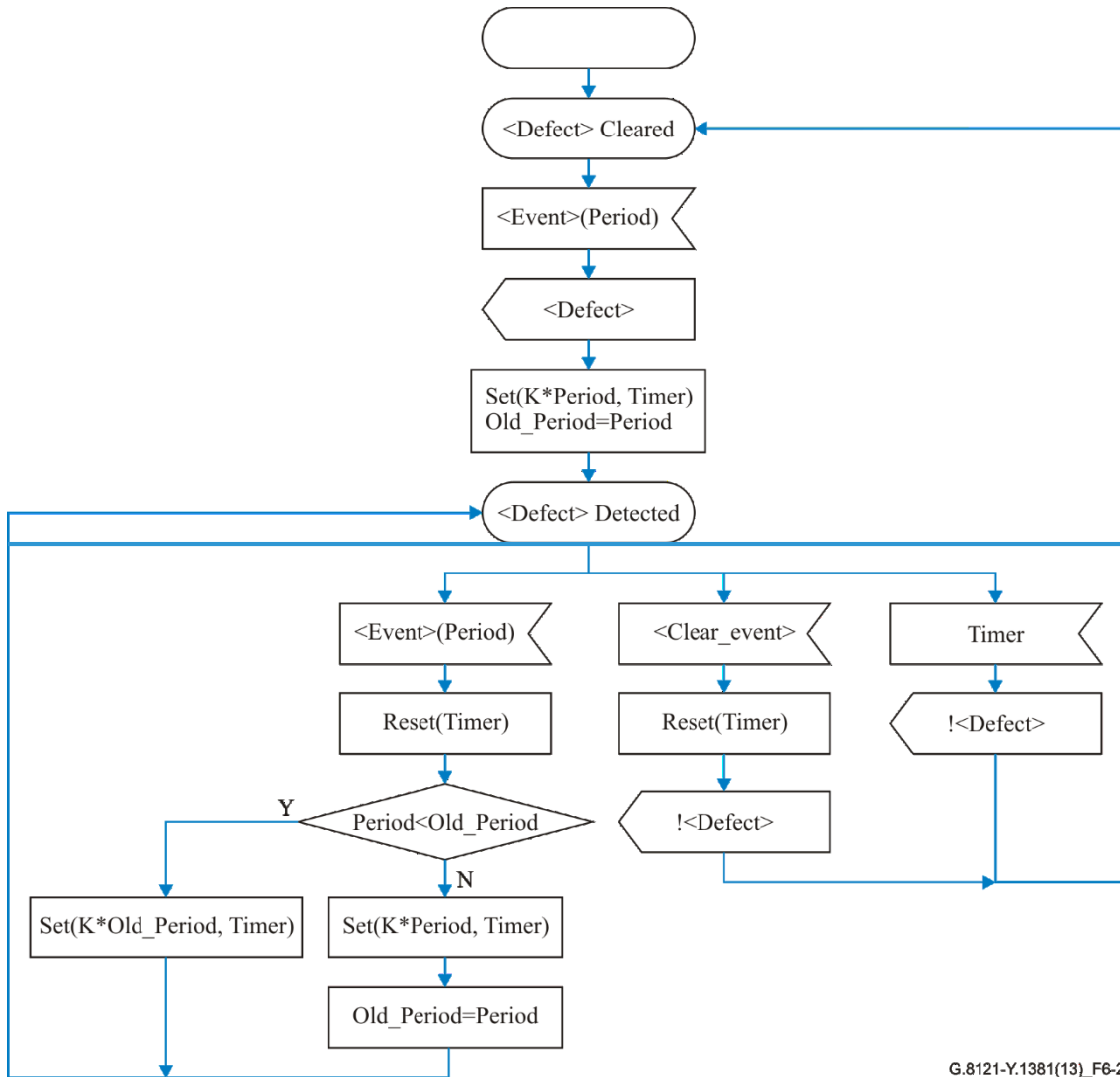
### 6.1.2.1 Loss Of Continuity defect (dLOC)

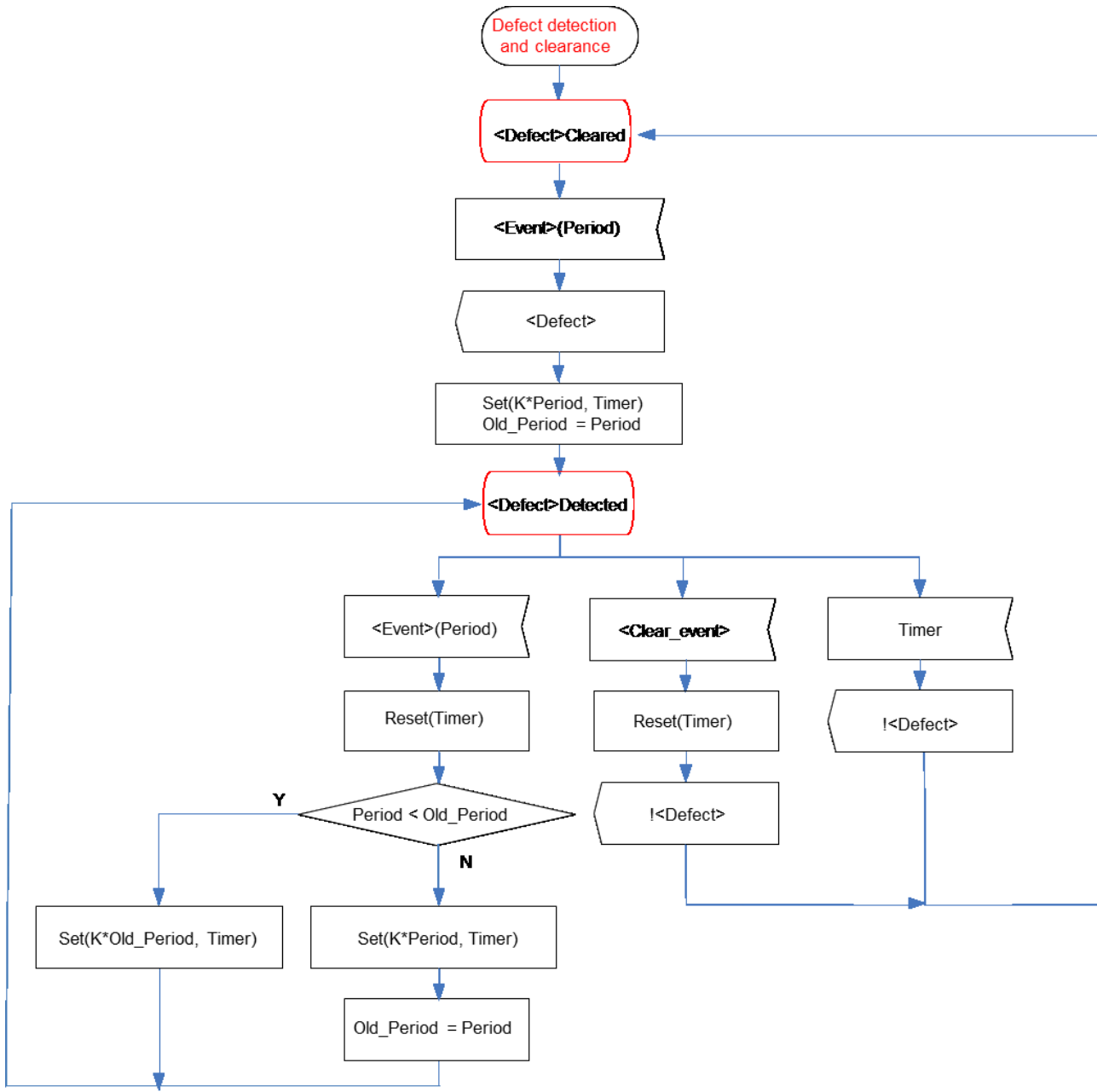
The Loss of Continuity defect is calculated at the MT layer. It monitors the presence of continuity in MT trails.

Its detection and clearance are defined in Figure 6-1. The 'period' in Figure 6-1 is set to  $K * MI\_CC\_Period$ , where  $MI\_CC\_Period$  corresponds to the configured CC Period and  $K$  is such that  $3.25 \leq K \leq 3.5$ .

### **6.1.3 Connectivity Supervision**







**Figure 6-2/G.8121/Y.1381 – Defect detection and clearance process for dMMG, dUNM, dUNP, dUNC, dAIS, dLCK and dCSF**

Figure 6-2 shows a generic state diagram that is used to detect and clear the dMMG, dUNM, dUNP, dUNC, dAIS, dLCK and dCSF (dCSF-LOS, dCSF-FDI, and dCSF-RDI) defects. In this diagram <Defect> needs to be replaced with the specific defect and <Event> with the specific event related to this defect. Furthermore in Figure 6-2  $3.25 \leq K \leq 3.5$ .

Figure 6-2 shows that the Timer is set based on the last received period value, unless an earlier OAM packet triggering <Event> (and therefore the detection of <Defect>) carried a longer period. As a consequence clearing certain defects may take more time than necessary.

### 6.1.3.1 Mismatch defect (dMMG)

The Mismatch defect detect is calculated at the MT layer. It monitors the connectivity in a Maintenance Entity Group.

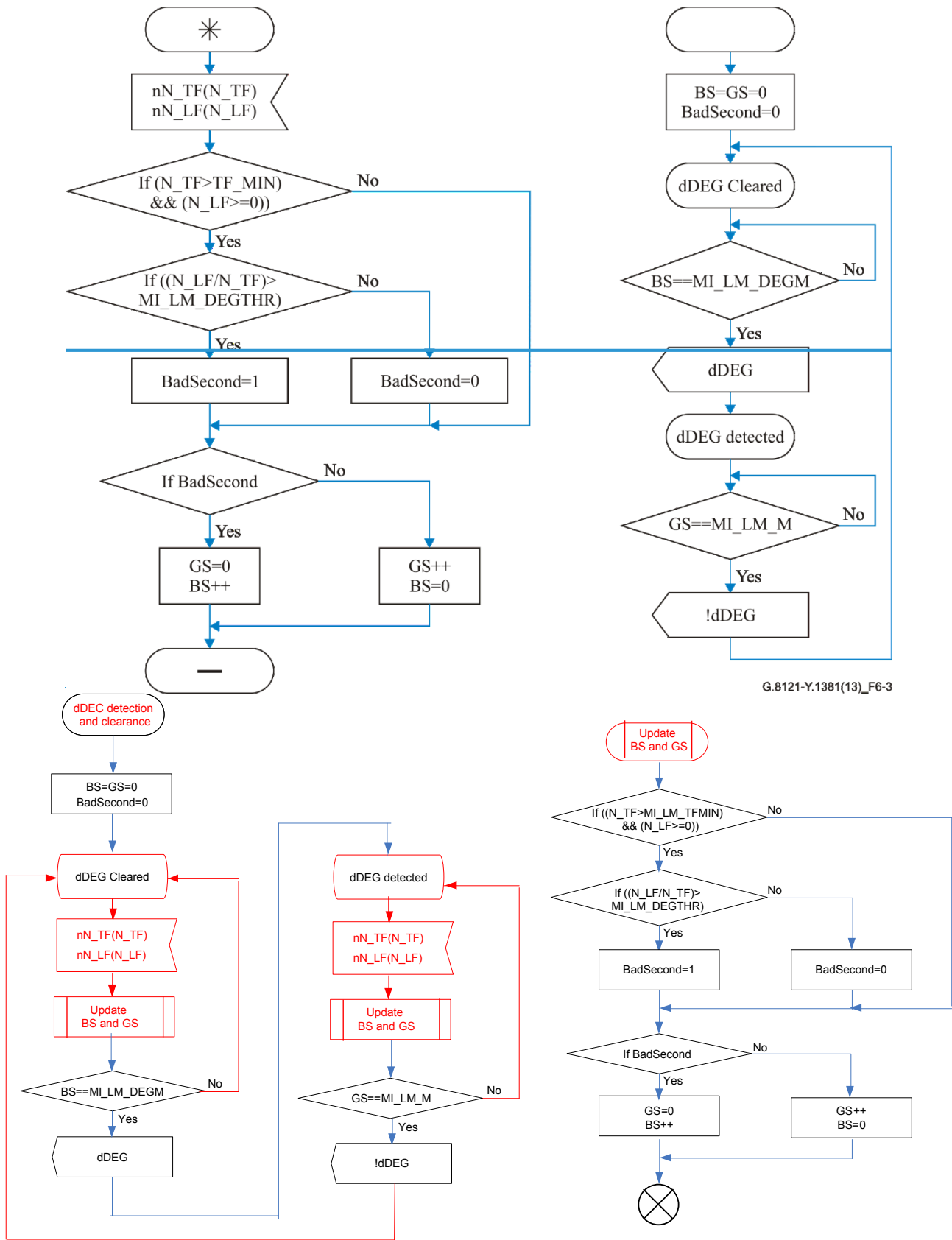
Its detection and clearance are defined in Figure 6-2. The <Defect> in Figure 6-2 is dMMG. The <Event> in Figure 6-2 is the unexpectedMEG event and the Period is the Period carried in the CV packet that triggered the event, unless an earlier CV packet triggering an unexpectedMEG event carried a greater period.

#### **6.1.3.2 Unexpected MEP defect (dUNM)**

The Unexpected MEP defect is calculated at the MT layer. It monitors the connectivity in a Maintenance Entity Group.

Its detection and clearance are defined in Figure 6-2. The <Defect> in Figure 6-2 is dUNM. The <Event> in Figure 6-2 is the unexpectedMEP event and the Period is the Period carried in the CV packet that triggered the event, unless an earlier CV packet triggering an unexpectedMEP event carried a greater period.

### 6.1.3.3 Degraded Signal defect (dDEG)



G.8121-Y.1381(13)\_F6-3

Figure 6-3/G.8121/Y.1381 – dDEG detection and clearance process

The Degraded Signal defect is calculated at the MT layer. It monitors the connectivity of a MT Trail.

Its detection and clearance are defined Figure 6-3.

Every second the state machine receives the 1 second counters for near end received and transmitted frames and determines whether the second was a Bad Second. The defect is detected if there are MI\_LM\_DEGM consecutive Bad Seconds and cleared if there are MI\_LM\_M consecutive Good Seconds.

In order to declare a Bad Second the number of transmitted frames must exceed a threshold (TF\_MIN). If this is true then a Bad Second is declared if either the Frame Loss is negative (i.e. there are more frames received than transmitted) or the Frame Loss Ratio (lost frames/transmitted frames) is greater than MI\_LM\_DEGTHR.

## 6.1.4 Protocol Supervision

### 6.1.4.1 Unexpected Periodicity defect (dUNP)

The Unexpected Periodicity defect is calculated at the MT layer. It detects the configuration of different periodicities at different MEPs belonging to the same MEG.

Its detection and clearance are defined Figure 6-2. The <Defect> in Figure 6-2 is dUNP The <Event> in Figure 6-2 is the unexpectedPeriod event and the Period is the Period carried in the CC-V packet that triggered the event, unless an earlier CC-V packet triggering an unexpectedPeriod event carried a greater period.

### 6.1.4.2 Unexpected CoS defect (dUNC)

The Unexpected CoS defect is detected at the MT layer. It detects the configuration error of different CoS at different MEPs belonging to the same MEG.

Its detection and clearance are defined Figure 6-2.

The <Defect> in Figure 6-2 is dUNC. The <Event> in Figure 6-2 is the unexpectedCoS event and the Period is the Period associated with the CC-V packet that triggered the event, unless an earlier CC-V packet triggering an unexpectedCoS event carried a greater period.

### 6.1.4.3 Protection protocol supervision

For linear protection, the failure of protocol defects are applied in the case of a bidirectional protection switching operation, where the coordination between two ends is needed.

#### 6.1.4.3.1 Linear protection failure of protocol provisioning mismatch on bridge type (dFOP-PMb)

The failure of protocol provisioning mismatch - bridge type defect is calculated at the MT layer. It monitors the provisioning mismatch on bridge type:

- by comparing bridge type (i.e. selector bridge or permanent bridge) PT (Protection Type) fields of the transmitted and the received APS packets. If the value of the PT field of one side is 2 (i.e., selector bridge) and the value of PT field of the other side is 1 or 3 (i.e., permanent bridge), then this will result in an APCb event as defined in Table 6-1. The reception of an APS packet with incompatible bridge type results in APSb event as defined in Table 6-1.

In case of APS protocol defined in [ITU-T G.8131], the bridge type is signalled in the PT (Protection Type) field as defined in clause 8 of [ITU-T G.8131]. If the value of the PT field of one side is 2 (i.e., selector bridge) and the value of PT field of the other side is 1 or 3 (i.e., permanent bridge), then this will result in an APCb event as defined in Table 6-1

Its detection and clearance are defined in Table 6-2. dFOP-PMb is:

- detected on receipt of an APSb event and cleared on receipt of an expAPS event.

The detection and clearance events of the defects are generated by the subnetwork connection protection process (Clause 9.1.1).

#### **6.1.4.3.2 Linear protection failure of protocol provisioning mismatch on Capabilities TLV (dFOP-PMc)**

The failure of protocol provisioning mismatch – Capabilities TLV defect is calculated at the MT layer. It monitors the provisioning mismatch on Capabilities TLV as defined in Clause 8.1 of [ITU-T G.8131]:

- by comparing the 12 octet Capabilities TLV information of the received APS packets with the default values defined in Clause 8.1 of [ITU-T G.8131].

Its detection and clearance are defined in Table 6-2. dFOP-PMc is:

- detected on receipt of an APSc event and cleared on receipt of an expAPS event.

The detection and clearance events of the defects are generated by the subnetwork connection protection process (Clause 9.1.1).

#### **6.1.4.3.3 Linear protection failure of protocol no response (dFOP-NR)**

The failure of protocol no response defect is calculated at the MT layer. It monitors incompleteness of protection switching by comparing the transmitted "Data Path" and the received "Data Path" values in the APS protocol.

Its detection and clearance are defined in Table 6-2. dFOP-NR is detected when an APSr event continues for more than 50ms and it is cleared on receipt of the expAPS event.

The detection and clearance events of the defects are generated by the subnetwork connection protection process (Clause 9.1.1).

#### **6.1.4.3.4 Linear protection failure of protocol configuration mismatch (dFOP-CM)**

The failure of protocol configuration mismatch defect is calculated at the MT layer. It monitors working and protection configuration mismatch by detecting the receipt of the APS packet from the working transport entity.

Its detection and clearance are defined in Table 6-2. dFOP-CM is detected on receipt of an APSw event and cleared on receipt of no APSw event during K times the long APS transmission period defined in [ITU-T G.8131], where  $3.25 \leq K \leq 3.5$ .

The detection and clearance events of the defects are generated by the subnetwork connection protection process (Clause 9.1.1).

#### **6.1.4.3.5 Linear protection failure Failure of protocol time out (dFOP-TO)**

The failure of protocol time out defect is calculated at the MT layer. It monitors the time out defect:

- by detecting the prolonged absence of expected APS [frames/packets](#).

Its detection and clearance are defined in Table 6-2.

dFOP-TO is detected on receipt of no expAPS event during K times the long APS interval defined in [ITU-T G.8131] (where  $K \geq 3.5$ ) ~~when neither dLOC nor CI\_SSF are reported~~. dFOP-TO is cleared on receipt of an expAPS event.

The detection and clearance events of the defects are generated by the subnetwork connection protection process (Clause 9.1.1).

### **6.1.5 Maintenance Signal Supervision**

#### **6.1.5.1 Remote Defect Indicator defect (dRDI)**

The Remote Defect Indicator defect is detected at the MT layer. It monitors the presence of the RDI maintenance signal.

dRDI is detected on receipt of the RDI=1 event and cleared on receipt of the RDI=0 event.

#### **6.1.5.2 Alarm Indicate Signal defect (dAIS)**

The Alarm Indicate Signal defect is detected at the MT layer. It monitors the presence of the AIS maintenance signal.

Its detection and clearance are defined Figure 6-2. The <Defect> in Figure 6-2 is dAIS. The <Event> in Figure 6-2 is the AIS event and the Period is the Period associated with the AIS packet unless an earlier AIS packet associated with a greater period.

#### **6.1.5.3 Locked Defect (dLCK)**

The Locked defect is detected at the MT layer. It monitors the presence of the Locked maintenance signal.

Its detection and clearance are defined Figure 6-2. The <Defect> in Figure 6-2 is dLCK. The <Event> in Figure 6-2 is the LCK event and the Period is the Period associated with the LCK packet unless an earlier LCK packet associated with a greater period.

#### **6.1.5.4 Client Signal Fail defect (dCSF)**

The CSF (CSF-LOS, CSF-FDI, and CSF-RDI) defect is detected at the MT layer. It monitors the presence of the CSF maintenance signal.

Its detection and clearance conditions are defined in Figure 6-2. The <Defect> in Figure 6-2 is dCSF-LOS, dCSF-FDI, or dCSF-RDI. The <Event> in Figure 6-2 is the CSF event and the Period is the Period associated with the CSF packet unless an earlier CSF packet associated with a greater period

The <Clear\_event> in Figure 6-2 is the CSF event which indicates Detect Clearance Indication (DCI).

## **6.2 Consequent actions**

For generic consequent actions, see [ITU-T G.806]. For the specific consequent actions applicable to MPLS-TP, refer the specific atomic functions.

## **6.3 Defect correlations**

For the defect correlations, see the specific atomic functions.

## **6.4 Performance filters**

*For further study.*

## **7 Information flow across reference points**

Information flow for MPLS-TP functions is defined in clause 9. A generic description of information flow is defined in clause 7 of [ITU-T G.806].

## **8 MPLS-TP processes**

This clause defines the specific processes for the MPLS-TP network. Generic processes are defined in clause 8 [ITU-T G.806].

### **8.1 G-ACh Process**

#### **8.1.1 Overview**

In order to ensure proper operational control, MPLS-TP network elements exchange OAM packets that strictly follow the same path as user traffic packets; that is, OAM packets are subject to the exact same forwarding schemes (e.g. fate sharing) as the user traffic packets. These OAM packets can be distinguished from the user traffic packets by using the G-ACh and GAL constructs.

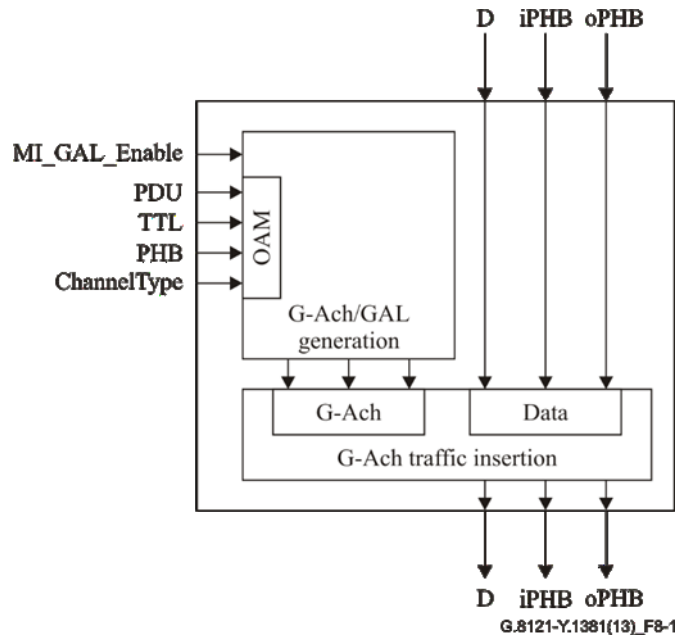
The G-ACh is a generic associated control channel mechanism for Sections, LSPs and PWs, over which OAM and other control messages can be exchanged. The GAL is a label based exception mechanism to alert LERs/LSRs of the presence of an Associated Channel Header (ACH) after the bottom of the stack.

The format of GAL and ACH is described in [IETF RFC 5586].

#### **8.1.2 G-ACh Insertion Process**

Figure 8-1 describes G-ACh Insertion process.





**Figure 8-1/G.8121/Y.1381 – G-ACh Insertion Process**

The G-ACh Insertion process encapsulates OAM packets and multiplexes them with the data packets. The data packets are passed through unchanged, while the OAM packets are encapsulated as follows:

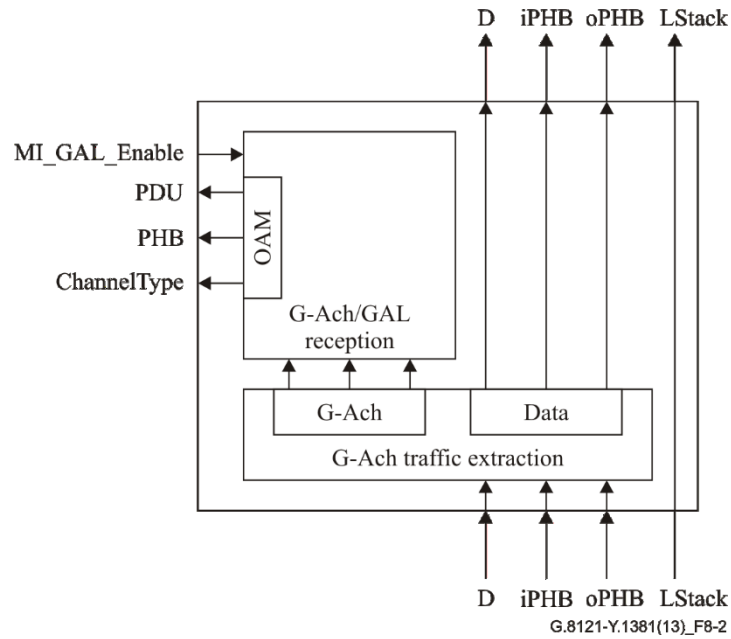
A G-ACh header is prepended to the OAM PDU, with the Channel Type set to the specified value. If MI\_GAL\_Enable is true, the process then further prepends a G-ACh Label (GAL) as described in [IETF RFC 5586]. If the TTL signal is not specified, the TTL field in the MI\_CI\_D is set to 255; otherwise it is set to the value in the TTL signal. If a GAL is inserted, the TTL field in the GAL LSE is set as defined in [IETF RFC 5586].

Note: certain OAM packets can be addressed to a MIP and thus need to be inserted with a specific TTL to ensure that the TTL expires at the target MIP. OAM packets addressed to a MEP have the TTL set to 255.

Note: MI\_GAL\_Enable must be set to true on LSPs and to false on PWs. Setting it to true for PWs is for further study.

### 8.1.3 G-Ach Extraction Process

Figure 8-2 describes G-ACh Extraction process.



**Figure 8-2/G.8121/Y.1381 – G-ACh Extraction Process**

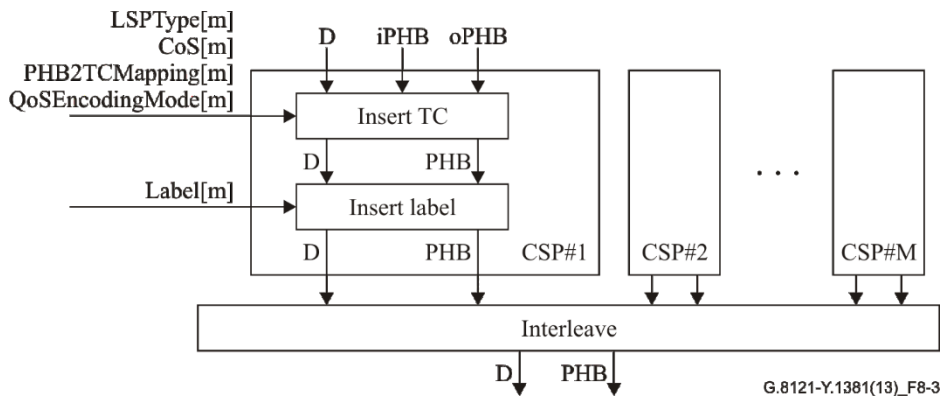
The G-ACh Traffic Unit will be extracted if it includes GAL and ACH in incoming Data when MI\_GAL\_Enable is set..

## 8.2 TC/Label processes

The TC/Label processes can operate in two modes, as described in clause 7.3 [ITU-T G.8110.1]. Mode 1 is the default mode and is mandatory. Mode 2 is optional and is only used for section monitoring. The mode is set as MI\_Mode by the EMF; it is expected that the EMF sets this automatically to the appropriate value depending on whether the MEP is monitoring a section or a PW/LSP. It is not expected that this MI is exposed to the user.

Note: MI\_Mode is always set to mode 1 when the TC/Label process is within an MT/MT\_A function, since an MPLS section is the lowest monitoring level and is only applicable to monitoring directly over the (non-MPLS) server layer. In a Server/MT\_A function, the TC/Label process may operate in mode 1 (if there is no section MEP) or mode 2 (if there is a section MEP).

### 8.2.1 TC/Label source processes



**Figure 8-3/G.8121/Y.1381 – TC/Label source processes in Mode 1**

Figure 8-3 shows the TC/Label source processes when MI\_Mode is set to mode 1. These processes are performed on a packetframe-per-frame-packet basis.

**Client Specific Processes:** The function supports M ( $M \leq 2^N - 16$ , with  $N = 20$  for MPLS label) client specific processes (CSP#1 to CSP#M), each connected to a single MPLS-TP connection point. CSP#m ( $1 \leq m \leq M$ ) is active when Label[m] has a value in the range 16 to  $2^N - 1$ .

**TC Insertion process:** Insert the TC field encoding the PHB information according to the following rules:

- If LSPTType[m] = L-LSP, the DP information is encoded into the TC field according to [ITU-T G.8110.1] and CoS[m].
- If LSPTType[m] = E-LSP, the PHB information is encoded into the TC field according to the 1:1 mapping configured in the PHB2TCMapping[m].

Note - E-LSP and L-LSP are referred to [ITU-T G.8110.1]

The PHB information to map into the TC field is selected according to the following rules:

- If QoSEncodingMode[m] = A, the iPHB information is mapped into the TC field.
- If QoSEncodingMode[m] = B, the oPHB information is mapped into the TC field.

**Label Insertion process:** Insert the 20-bit MPLS Label field with the value provided via Label[m].

**Interleave process:** Interleave the MPLS-TP traffic units from the client specific processes into a single stream.

When MI\_Mode is set to mode 2, the TC/Label Source process simply deletes the TTL and S fields from each MPLS traffic unit.

## 8.2.2 TC/Label Sink Processes

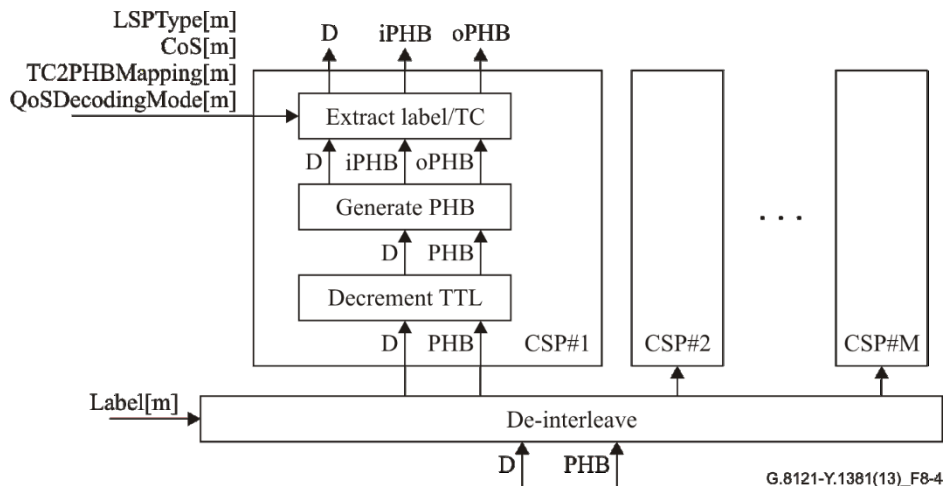


Figure 8-4/G.8121/Y.1381 – TC/Label sink processes in Mode 1

Figure 8-4 shows the TC/Label sink processes when MI\_Mode is set to mode 1. These processes are performed on a [framepacket-per-framepacket](#) basis.

**De-Interleave process:** De-interleave the MPLS-TP traffic units and forwards each of its Client Specific Process #m based on the value in the Label field of the traffic unit. Relation between CSP and MPLS label value is provided by Label[1..M].

Traffic units received with a label value identifying a non-active CSP are dropped.

**Client Specific Processes:** The function supports M ( $M \leq 2^N - 16$ , with  $N = 20$  for MPLS label) client specific processes (CSP#1 to CSP#M), each connected to a single MPLS-TP connection point. CSP#m ( $1 \leq m \leq M$ ) is active when Label[m] has a value in the range 16 to  $2^N - 1$ .

**Label and TC Extraction process:** Extract the MPLS label and the TC fields from the traffic unit.

**TTL Decrement Process:** Decrements the TTL. If the MPLS-TP CP is not a TCP and the decremented TTL is less than or equal to zero, the traffic unit is dropped silently.

NOTE – MIPs and MEPs compound functions are connected to the Server/MT\_A (or MT/MT\_A) functions via an MPLS-TP TCP.

**PHB Generation process:** Processes the TC field.

The iPHB signal is generated according to the following rules:

- If LSPTYPE[m] = L-LSP, the CoS information is equal to the CoS[m] while the DP information is decoded from the TC field according to [ITU-T G.8110.1] and the CoS[m].
- If LSPTYPE[m] = E-LSP, the PHB information is decoded from the TC field according to the 1:1 mapping configured in the TC2PHBMapping[m].

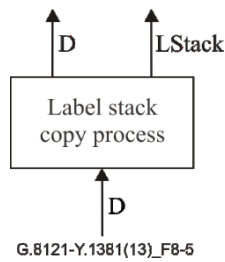
Note - E-LSP and L-LSP are referred to [ITU-T G.8110.1]

The CI\_oPHB is generated according to the following rule:

- If QoSDecodingMode = A, the oPHB is equal to the generated iPHB.
- If QoSDecodingMode = B, the oPHB is equal to the received PHB.

When MI\_Mode is set to mode 2, the TC/Label Sink process simply inserts a TTL and an S field on to each MPLS traffic unit, with the values set to 254 and 0 respectively.

### 8.2.3 Label Stack Copy Process



**Figure 8-5/G.8121/Y.1381 – Label Stack Copy Process**

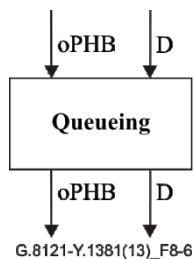
Figure 8-5 shows Label Stack Copy Process. It passes through the CI\_D unchanged and copies from the CI\_D traffic unit the complete label stack.

The LStack information is lost at the input of Server/MT and MT/MT source adaptation function and at the input of MT/Client sink adaptation function.

### 8.3 Queuing process

The queuing process buffers received MPLS packets for output according to the CI\_oPHB. Figure 8-6 shows Queuing process. The details of the queuing process implementation are out of the scope of this Recommendation.

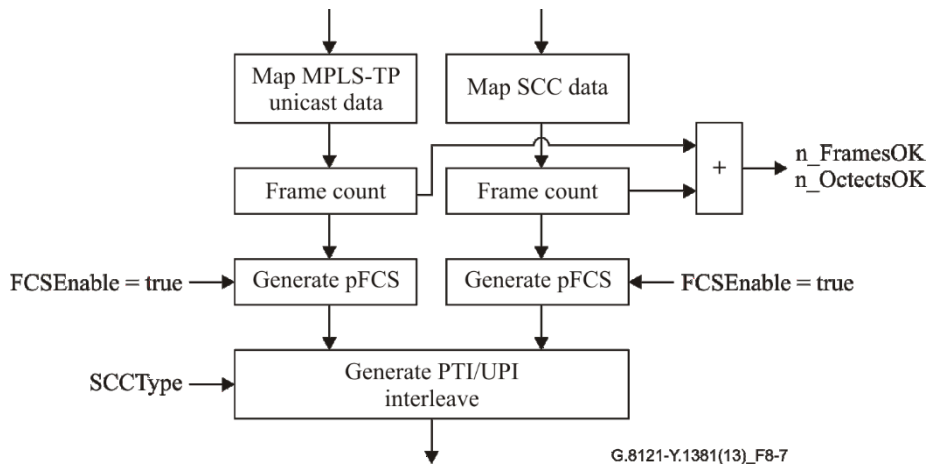
The queuing process is also responsible for dropping [frames-packets](#) if their rate at the MT\_CI is higher than the <Srv>\_AI\_D can accommodate. Performance monitor counters are for further study.



**Figure 8-6/G.8121/Y.1381 – Queuing process**

## 8.4 MPLS-TP-specific GFP-F processes

### 8.4.1 MPLS-TP-specific GFP-F source processes



**Figure 8-7/G.8121/Y.1381 – MPLS-TP-specific GFP-F source process**

Figure 8-7 shows the MPLS-TP-specific GFP-F source processes. These processes are performed on a [framepacket-per-frame-pac](#) basis.

**Mapping of MPLS-TP data:** The MPLS-TP packet is inserted into the client payload information field of the GFP frame as defined in 7.6 of [ITU-T G.7041]. One MPLS-TP packet results in one GFP frame.

**Mapping of SCC data:** The SCC frame is inserted into the client payload information field of the GFP frame as defined in clause 7 in [ITU-T G.7041]. One SCC packet results in one GFP frame.

**Frame Count:** It counts the number of frames (n\_FramesOK) and of octets (n\_OctetsOK) that passes through.

**pFCS generation:** See 8.5.4.1.1 in [ITU-T G.806]. GFP FCS is always enabled (FCSEnable=true).

**Generate PTI and UPI, Interleave:** The PTI field of the GFP type header is set fixed to "000". The UPI field of the GFP type header is set to:

- the MPLS UPI (as defined in Table 6-3 of [ITU-T G.7041]), for frames coming from the Map MPLS-TP data process;
- the SCC UPI according to SCC Type for frames coming from the Map SCC data process.

The frames are then interleaved to form a single stream.

NOTE 2 – GFP Client Management frames are not defined for MPLS-TP over GFP-F mapping.

## 8.4.2 MPLS-TP-specific GFP-F sink processes

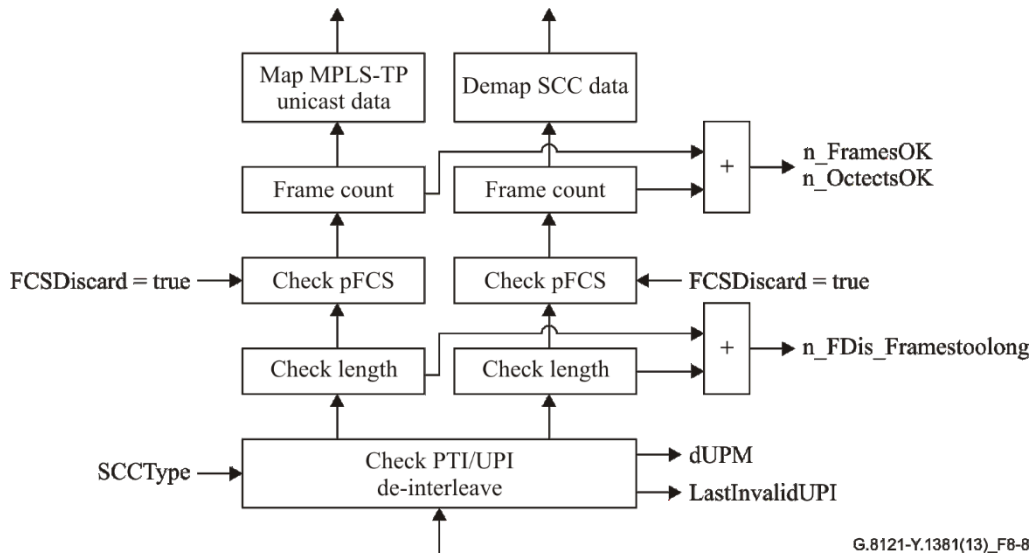


Figure8-8/G.8121/Y.1381 – MPLS-TP-specific GFP-F sink process

Figure 8-8 shows the MPLS-TP-specific GFP-F sink processes. These processes are performed on a framepacket-per-frame-packet basis.

**Check PTI and UPI, Deinterleave:** GFP frames with an accepted PTI (AcPTI, see 8.5.1.1 in [ITU-T G.806]) of "000" are client data frames. All GFP frames with an accepted PTI (AcPTI, see 8.5.1.1 in [ITU-T G.806]) value other than "000" shall be discarded.

The UPI of client data frames is checked to generate dUPM as follows:

- a "valid-UPI frame" is a frame with a UPI that equals either the MPLS UPI (as defined in Table 6-3 of [ITU-T G.7041]) or the SCC UPI according to SCCType. All other frames are "invalid-UPI frames".
- dUPM is raised as soon as one "invalid-UPI frame" is received.
- dUPM is cleared if no "invalid-UPI frames" have been received for the last Tclear seconds.

Tclear is for further study. If dUPM is active, the latest received invalid UPI is available at LastInvalidUPI. If dUPM is not active, LastInvalidUPI is "n/a".

The UPI of client data frames is further used to deinterleave the frames:

- "valid-UPI frames" with UPI equalling the MPLS UPI (as defined in Table 6-3 of [ITU-T G.7041]) are sent towards the "Demap MPLS-TP data" process.
- "valid-UPI frames" with UPI equalling the SCC UPI according to SCCType (as defined in Table 6-3 of [ITU-T G.7041]) are sent towards the "Demap SCC data" process.
- "invalid-UPI frames" are discarded.

**GFP-F frame length:** It checks whether the length of the GFP-F frame is allowed. Frames longer than GFP\_Length bytes are dropped and counted (n\_FramesTooLong).

NOTE 1 – GFP\_Length is for further study.

**pFCS Supervision:** See 8.5.4.1.2 in [ITU-T G.806]. The discarding of errored frames is always enabled (FCSdiscard=true). If the accepted PFI is 0, the frame is dropped and counted (n\_FDis\_PFI).

**Frame Count:** It counts the number of frames (n\_FramesOK) and of octets (n\_OctetsOK) that passes through.

**Demapping of SCC data:** The SCC packet is extracted from the client payload information field of the GFP frame as defined in clause 7 of [ITU-T G.7041]. One GFP frame results in one SCC frame.

**Demapping of unicast MPLS-TP data:** The MPLS-TP packet is extracted from the client payload information field of the GFP frame as defined in 7.6 of [ITU-T G.7041]. One GFP frame results in one MPLS-TP packet.

## 8.5 Control Word (CW) processes

This function performs the Control Word (CW) processing as described in [IETF RFC 4448]. The CW is known as the common interworking indicators (CII) in [ITU-T Y.1415].

### 8.5.1 CW insertion process

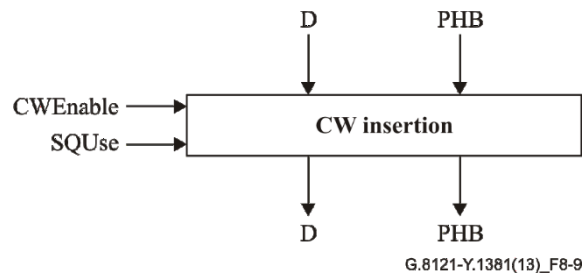


Figure 8-9/G.8121/Y.1381 – CW insertion process

Figure 8-9 shows CW insertion process. This function should generate and insert the CW as described in [IETF RFC 4448] if the indication CWEnable is true. Otherwise no insertion should be performed. If the indication SQUse is false, the sequence number field should be set at all zeroes.

### 8.5.2 CW extraction Process

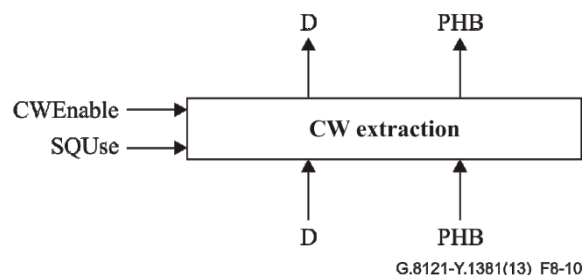


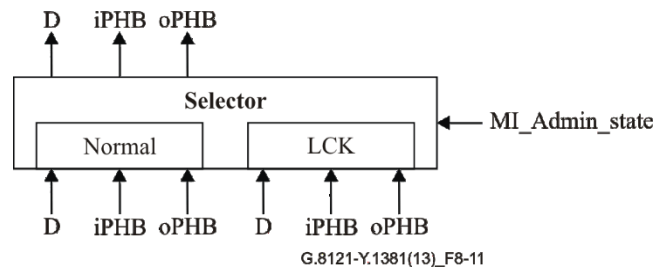
Figure 8-10/G.8121/Y.1381 – CW extraction process

Figure 8-10 shows CW extraction process. This function should process and remove the CW as described in [RFC 4448], if the indication CWEnable is true. In this case, if the indication SQUse is true, the sequence number field should be processed and out-of-sequence packets dropped (no reordering is performed by this process).



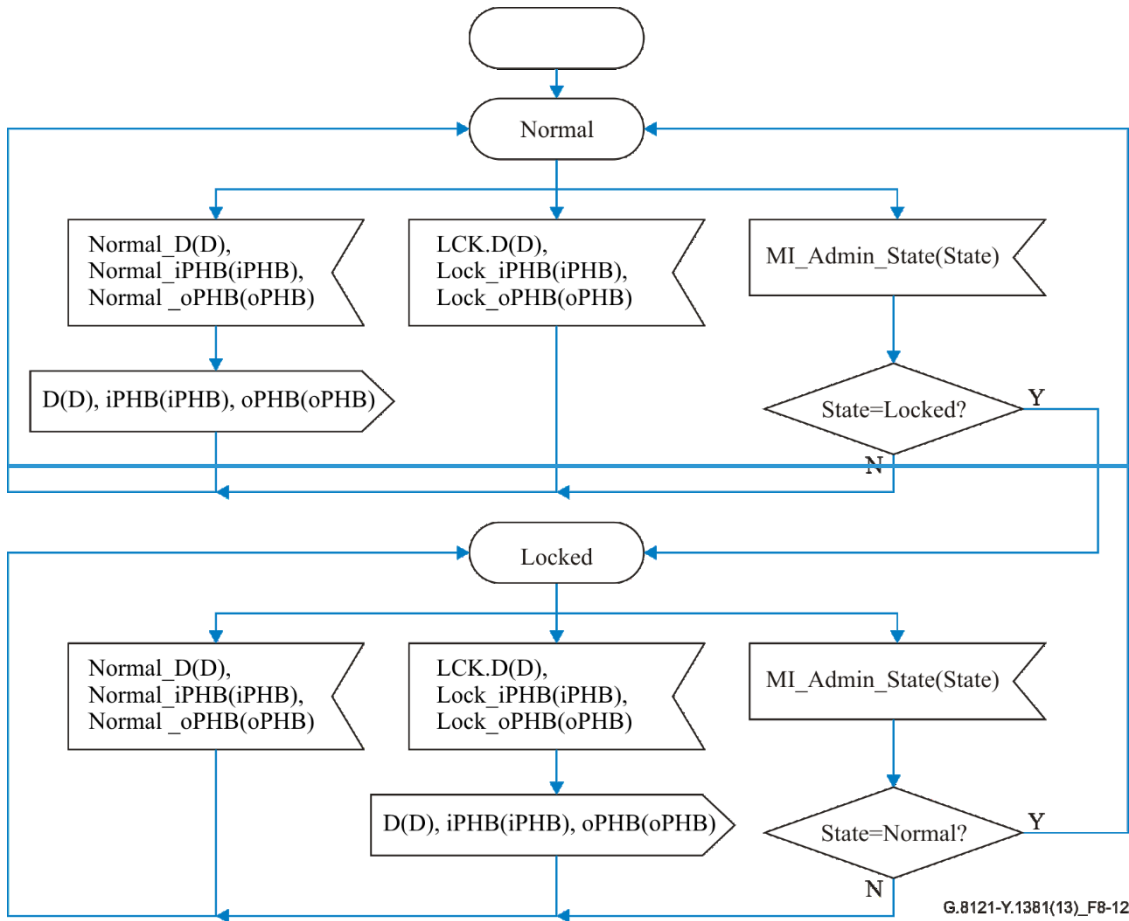
## 8.6 OAM related Processes used by Server adaptation functions

### 8.6.1 Selector Process



**Figure 8-11/G.8121/Y.1381 – Selector process**

Figure 8-11 shows the Selector Process Symbol. The Selector process selects the valid signal from the input of the normal MT\_CI signal or the MT\_CI LCK signal (as generated by the LCK Generation process in 8.6.3). The normal signal is blocked if MI\_Admin\_State is LOCKED. The behaviour is defined in Figure 8-12.



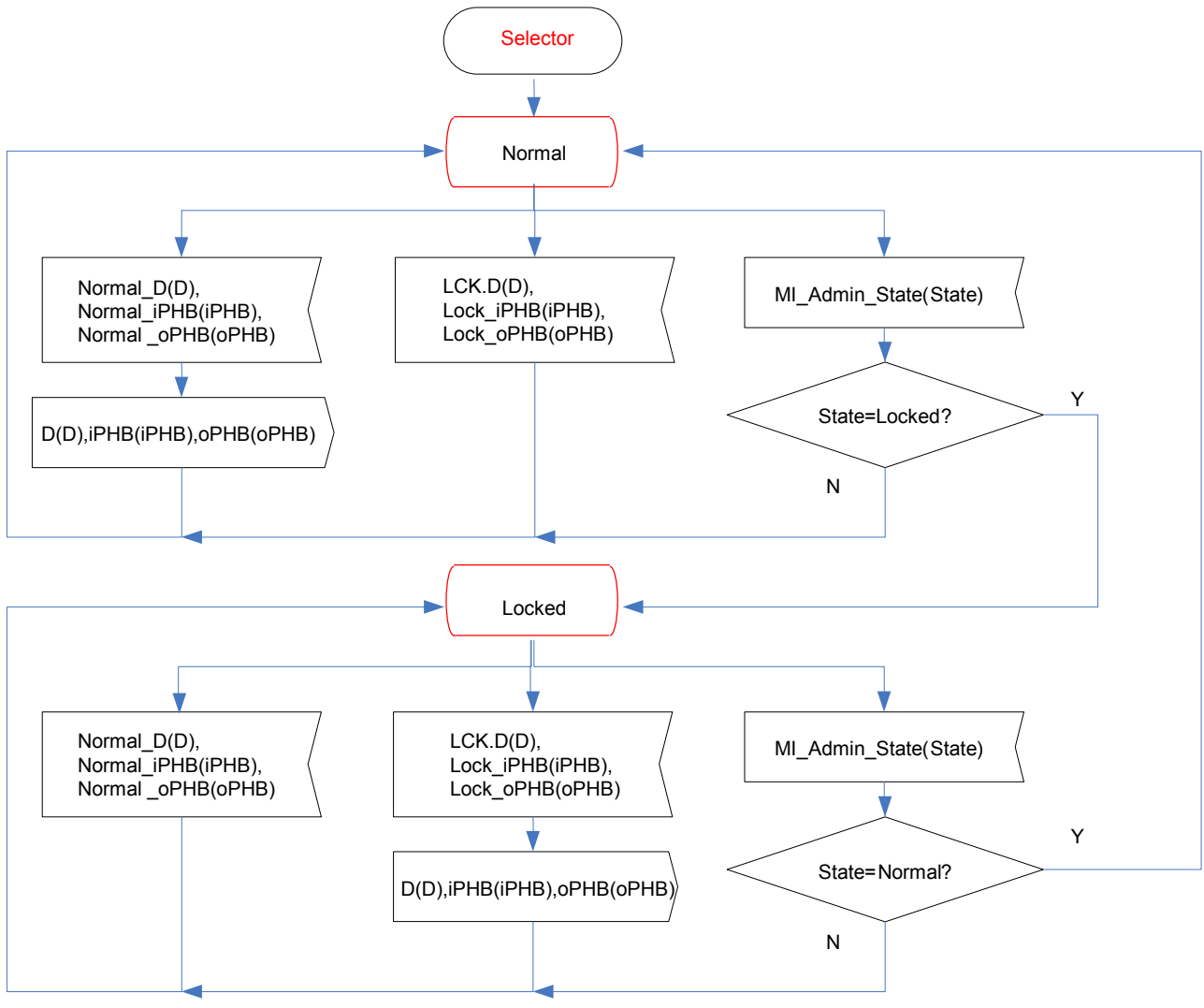
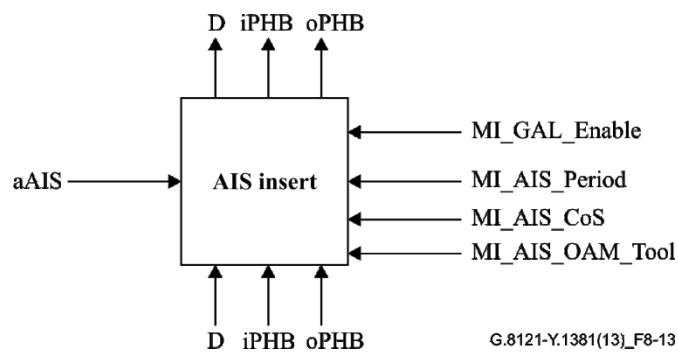


Figure 8-12/G.8121/Y.1381 – Selector Behaviour

### 8.6.2 AIS Insert Process



G.8121-Y.1381(13)\_F8-13

Figure 8-13/G.8121/Y.1381 – AIS Insert process

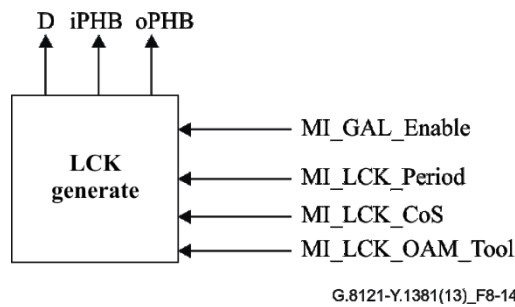
Figure 8-13 shows the AIS Insert Process Symbol. The generated AIS traffic units are inserted in the incoming stream, i.e., the output stream contains the incoming traffic units and the generated AIS traffic units.

The period between consecutive AIS traffic units is determined by the MI\_AIS\_Period parameter. The format of the AIS traffic units is defined by the MI\_AIS\_OAM\_Tool parameter. The generated

AIS traffic units are G-ACh encapsulated as described in Clause 8.1 which includes GAL or not depending on MI\_GAL\_Enable.

The value of the MT\_CI\_iPHB and MT\_CI\_oPHB signals associated with the generated AIS traffic units is the PHB with the lowest drop precedence within the CoS defined by the MI\_AIS\_CoS input parameter. As described in [IETF RFC 6371], AIS packets are transmitted with the "minimum loss probability PHB".

### 8.6.3 LCK Generate process

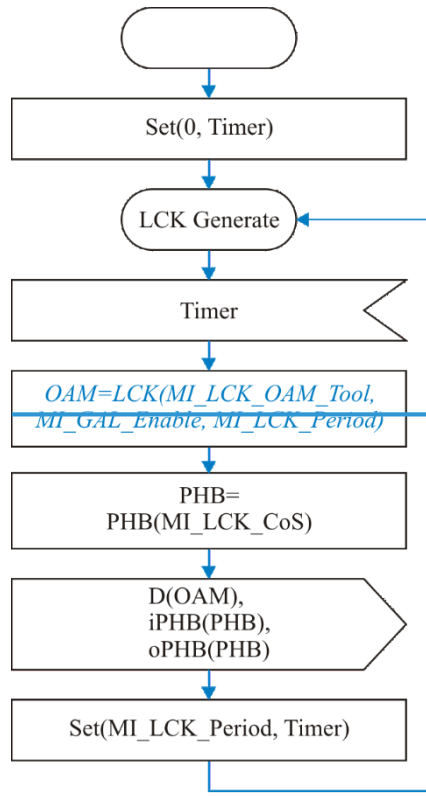


**Figure 8-14/G.8121/Y.1381 – LCK Generation process**

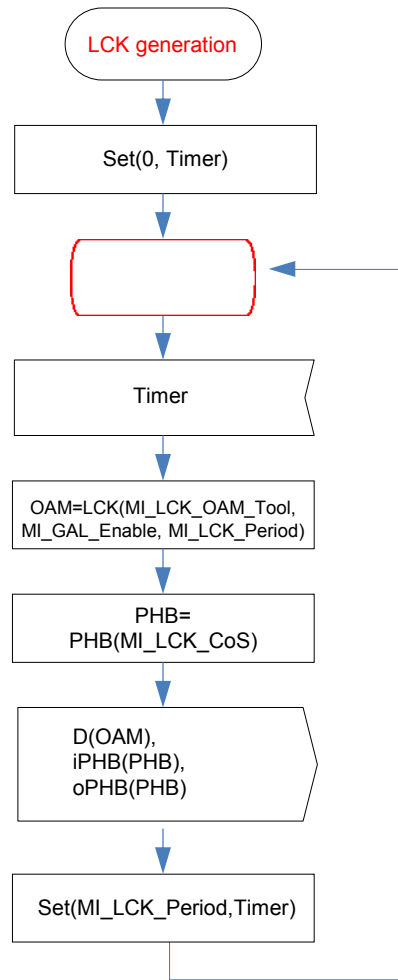
Figure 8-14 shows the LCK<sup>3</sup> Generation Process Symbol. The LCK Generation Process generates MT\_CI traffic units where the MT\_CI\_D signal contains the LCK signal. Figure 8-15 defines the behaviour of the LCK Generation Process.

---

<sup>3</sup> IETF uses the term LKR for this function



G.8121-Y.1381(13)\_F8-15



## **Figure 8-15/G.8121/Y.1381 – LCK Generation behaviour**

[Ed note: No need to use blue and italic fonts]

The LCK Generation Process continuously generates LCK Traffic Units. The period between consecutive LCK traffic units is determined by the MI\_LCK\_Period parameter.

The LCK(LCK\_OAM\_Tool, GAL\_Enable, Period) function generates a LCK Traffic Unit, whose format is defined by the LCK\_OAM\_Tool parameter, that encodes the period information defined by the value of the Period parameter. The generated traffic unit is G-ACh encapsulated, as described in clause 8.1, with or without the GAL depending on the GAL\_Enable parameter.

The value of the MT\_CI\_iPHB and MT\_CI\_oPHB signal associated with the generated LCK traffic units is the PHB with the lowest drop precedence within the CoS defined by the MI\_LCK\_CoS input parameter. The PHB(MI\_LCK\_CoS) function generates such PHB information. As described in [IETF RFC 6371], LCK packets are transmitted with the "minimum loss probability PHB".

### **8.7 OAM related Processes used by adaptation functions**

#### **8.7.1 MCC and SCC Mapping and DeMapping**

As defined in [ITU-T G.7712], an embedded communication channel (ECC) provides a logical operations channel between NEs that can be utilized by various applications. An MCC is an ECC dedicated for management plane communications. An SCC is an ECC dedicated for control plane communications.

The MCC mapping and de-mapping processes are provided to support the MT to MCC adaptation function for accessing to the MCC. The SCC mapping and de-mapping processes are provided to support the MT to SCC adaptation function for accessing to the SCC. The mapping and de-mapping processes for MCC is very similar to that of SCC. In the following description of this sub-clause and sub-clause 8.7.2, the term ECC will be used, which applies to both MCC and SCC.

##### **8.7.1.1 ECC Mapping**

The ECC mapping process is associated with the MT/MCC\_A\_So and MT/SCC\_A\_So functions, which are described in Clauses 10.2.2.1 and 10.2.1.1 respectively.

This process shall map the incoming ECC packet into G-ACh encapsulated ECC traffic unit (i.e., an MT\_AI\_D traffic units carrying an ECC packet).

The ECC traffic units generated by this process are encapsulated into the G\_ACh, as defined in [IETF RFC5718], using or not the GAL depending on the MI\_GAL\_Enable configuration parameters. The value of the MT\_AI\_PHB associated with the generated ECC traffic units is defined by the MI\_ECC\_CoS input parameter.

##### **8.7.1.2 ECC DeMapping**

The ECC DeMapping process is associated with the MT/MCC\_A\_Sk and MT/SCC\_A\_Sk functions, which are described in Clauses 10.2.2.2 and 10.2.1.2 respectively.

This process shall extract the ECC packet from the G-ACh encapsulated ECC traffic unit (i.e., MT\_AI\_D traffic units carrying ECC packets).

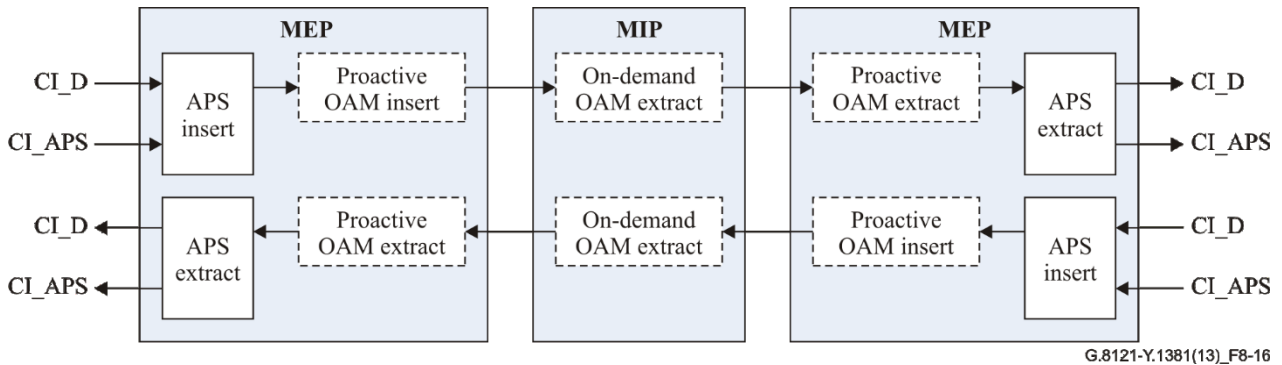
The criteria for selecting ECC traffic units are based on the values of the fields within the MT\_AI\_D signal:

- GAL included to the MT\_AI\_D if GAL usage is enabled via MI\_GAL\_Enable

- The Channel type of G-ACh indicates an MCC packet (in MT/MCC\_A\_Sk) or an SCC packet (in MT/SCC\_A\_Sk), as defined in [IETF RFC 5718]

### 8.7.2 APS Insert and Extract Processes

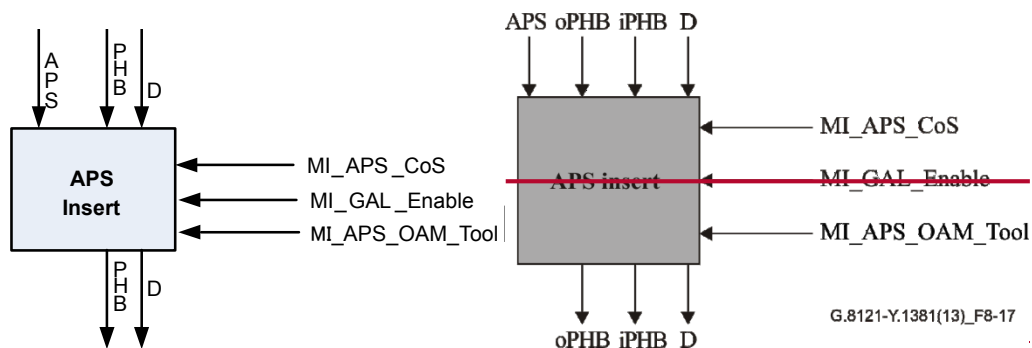
Figure 8-16 shows a protocol-neutral abstract model of the different processes inside MEPs and MIPs that are involved in the automatic protection switching (APS)<sup>4</sup> function.



**Figure 8-16/G.8121/Y.1381 – Overview of the processes involved with APS function**

APS Insert and Extract processes are located in MT/MT\_Adaptation function. [The CI\\_APS signal contains the APS specific information as defined in clause 8.2 of \[ITU-T G.8131\]](#) ~~CI\_APS signal carries APS specific information which is for further study.~~ APS traffic units are inserted into and extracted from the stream of MT\_CI\_D traffic units.

#### 8.7.2.1 APS Insert Process

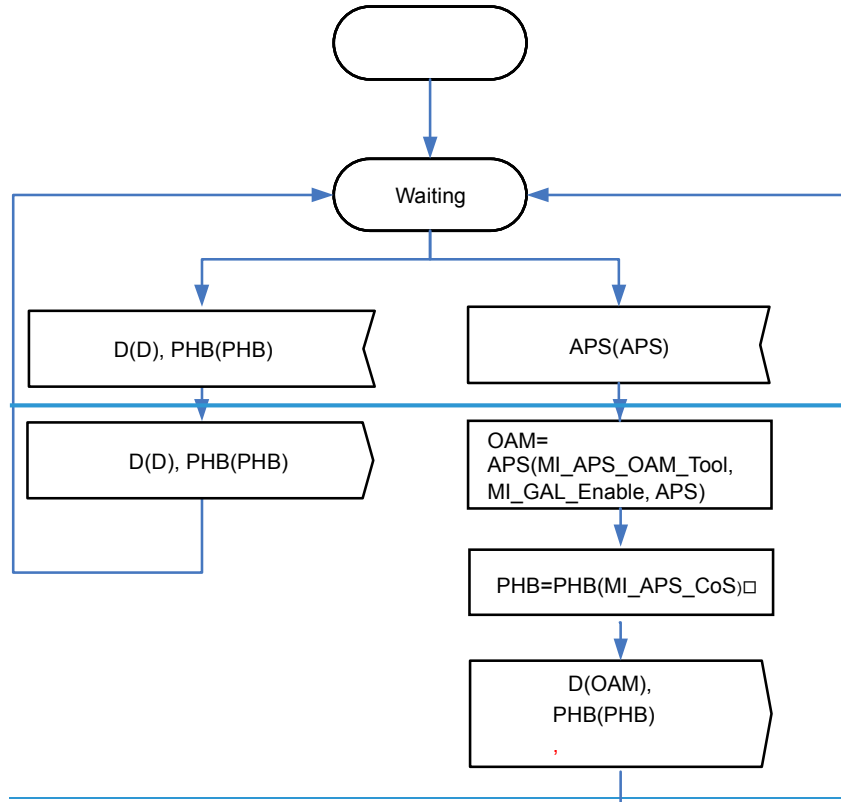
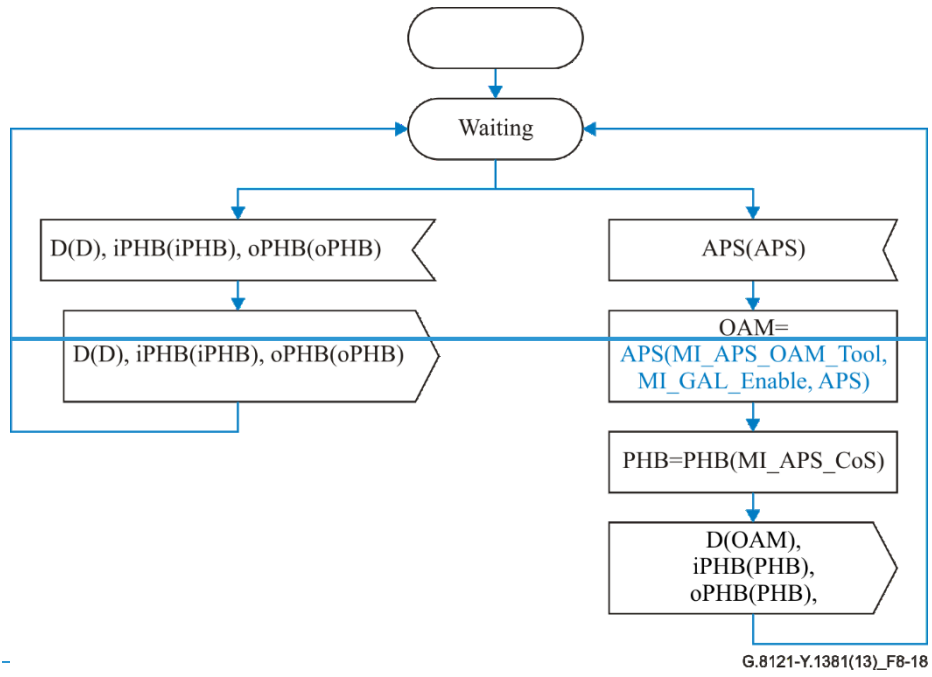


**Figure 8-17/G.8121/Y.1381 – APS Insert process**

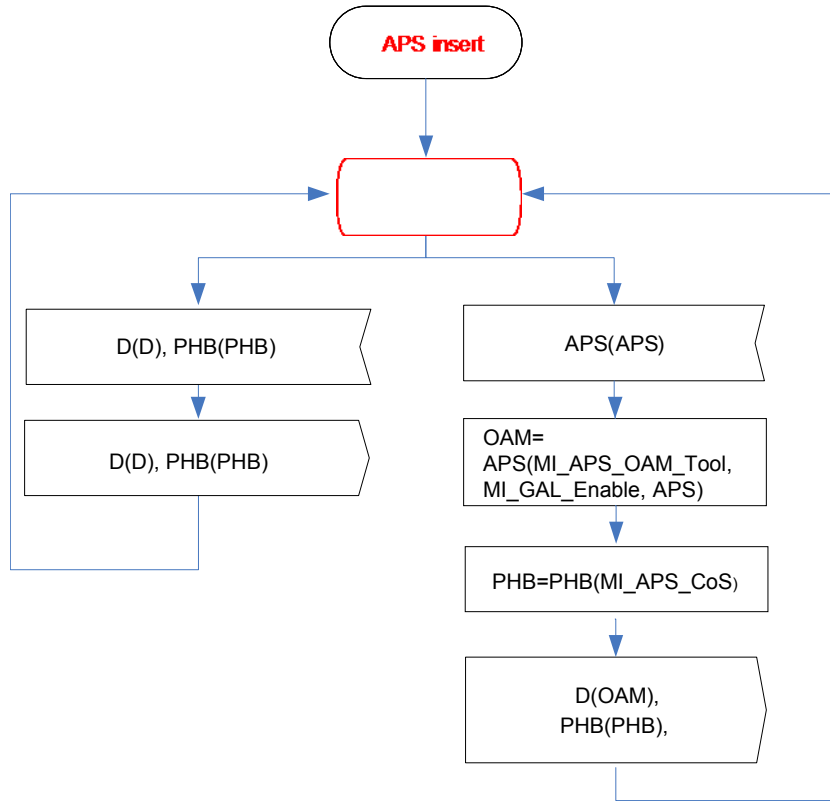
Figure 8-17 shows the APS Insert process and Figure 8-18 defines the behaviour. The resulting APS traffic unit is inserted into the stream of incoming traffic units, i.e., the outgoing stream consists of the incoming traffic units and the inserted APS traffic units. The MT\_CI\_APS signal contains the APS specific information as defined in [ITU-T G.8131].

~~[Note: It is required to draw how the out going APS traffic units (formats) as part of AI\_D, are represented. It consists of S bit, GAL, G\_Ach, and APS PDU.]~~

<sup>4</sup> [\[ITU-T G.8131\] conventionally uses the term APC for this function.](#)  
~~IETF uses the term PCS for this function in [b IETF RFC 6378]~~





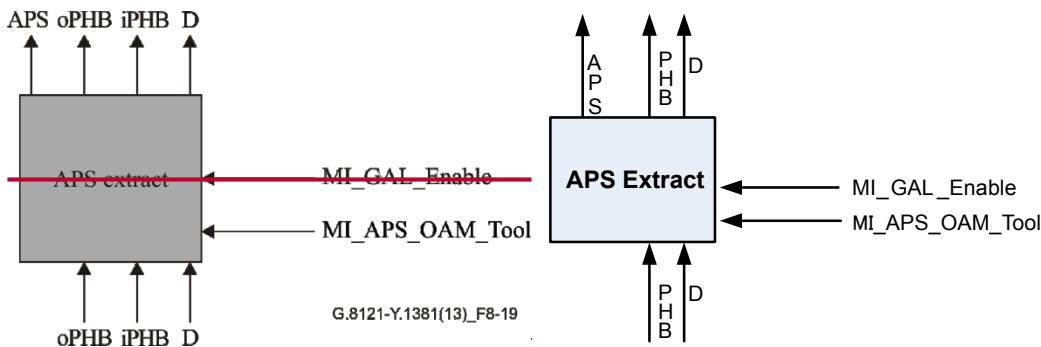


**Figure 8-18/G.8121/Y.1381 – APS Insert Behaviour**

The APS(APS\_OAM\_Tool, GAL\_Enable, APS) function generates an APS Traffic Unit, whose format is defined by the APS\_OAM\_Tool parameter, that encodes the APS information defined by the value of the APS parameter. The generated traffic unit is G-ACh encapsulated, as described in clause 8.1, with or without the GAL depending on the GAL\_Enable parameter.

The value of the MT\_AI\_PHB signals associated with the generated APS traffic units are the PHB with the lowest drop precedence within the CoS defined by the MI\_APS\_CoS input parameter. The PHB(MI\_APS\_CoS) function generates such PHB information.

**8.7.2.2 APS Extract Process**



**Figure 8-19/G.8121/Y.1381– APS Extract process**

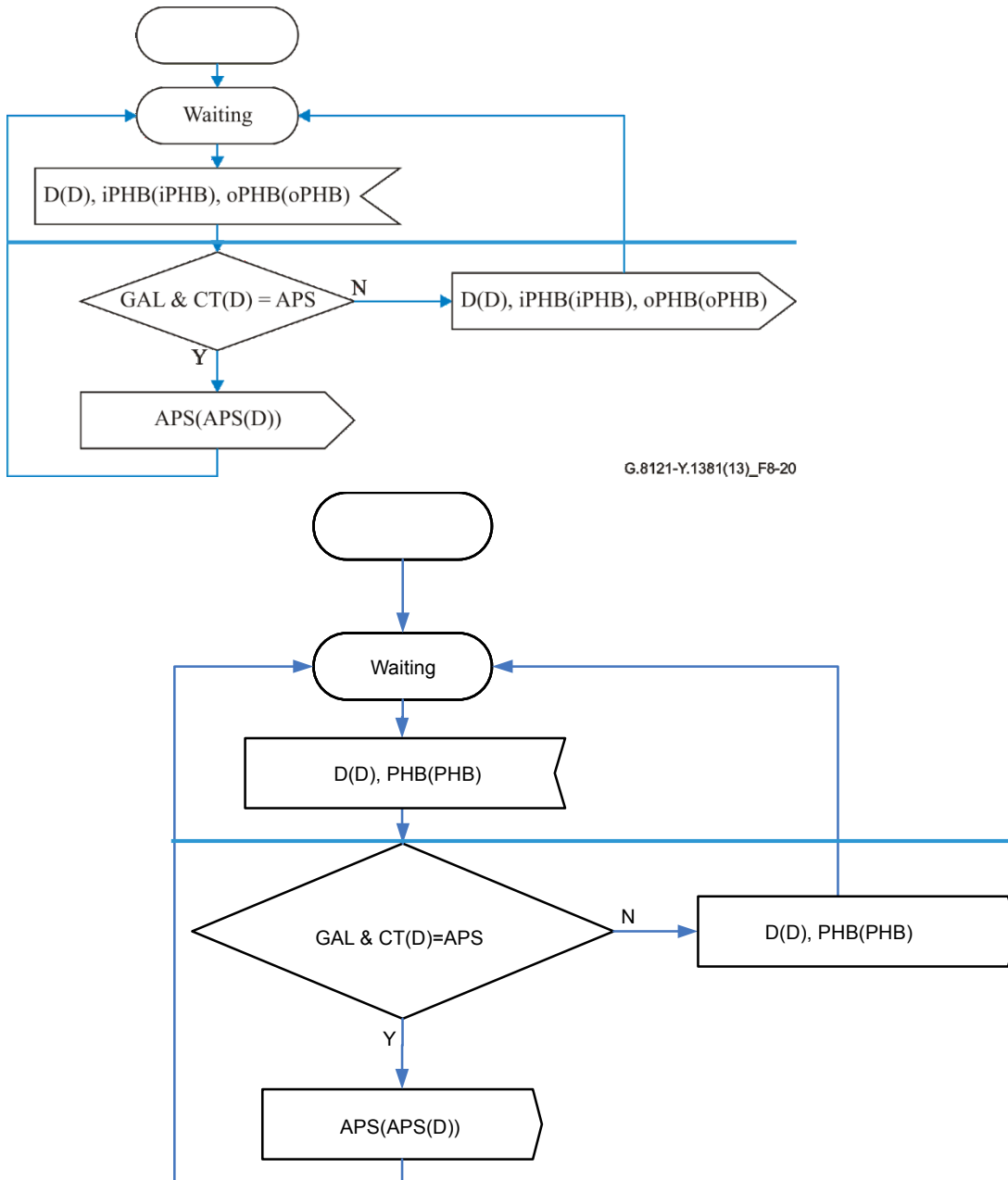
The APS Extract process extracts MT\_AI\_APS signals from the incoming stream of MT\_AI traffic units.

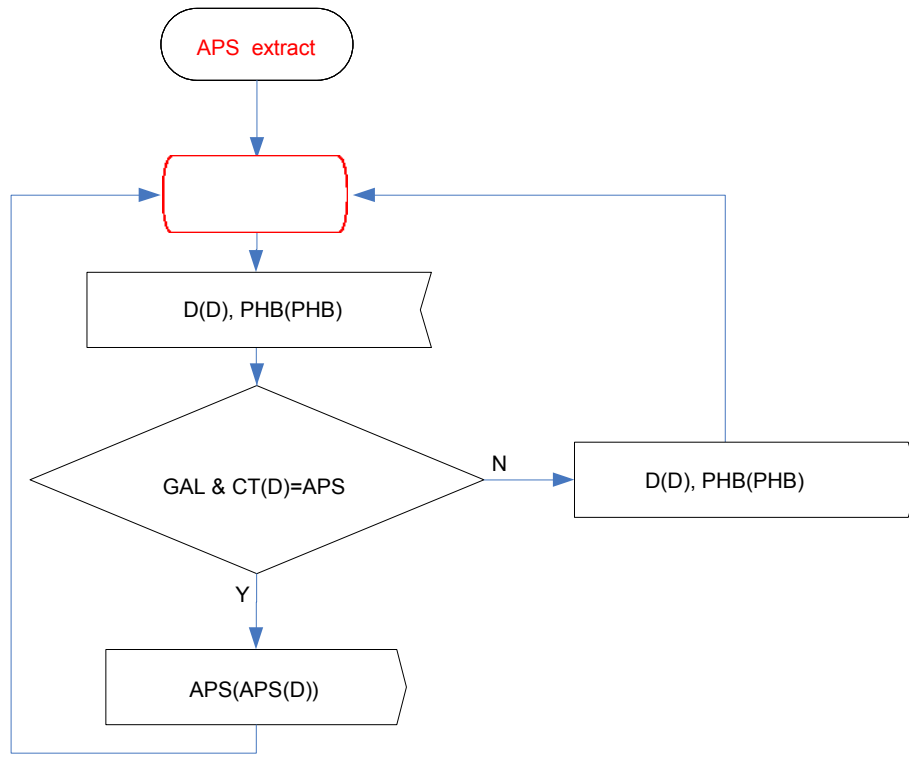
The MT\_AI\_APS is the APS Specific Information as described in [ITU-T G.8131] contained in the received Traffic Unit. All other traffic units will be transparently forwarded.

The criteria for filtering are based on the values of the fields within the MT\_AI\_D signal:

- S bit (1) and GAL included to the MT\_AI\_D if GAL usage is enabled via MI\_GAL\_Enable
- OAM type that is defined in Channel type of G-ACh indicates APS

This is defined in Figure 8-20. The function APS(D) extracts the APS specific information from the received Traffic Unit.

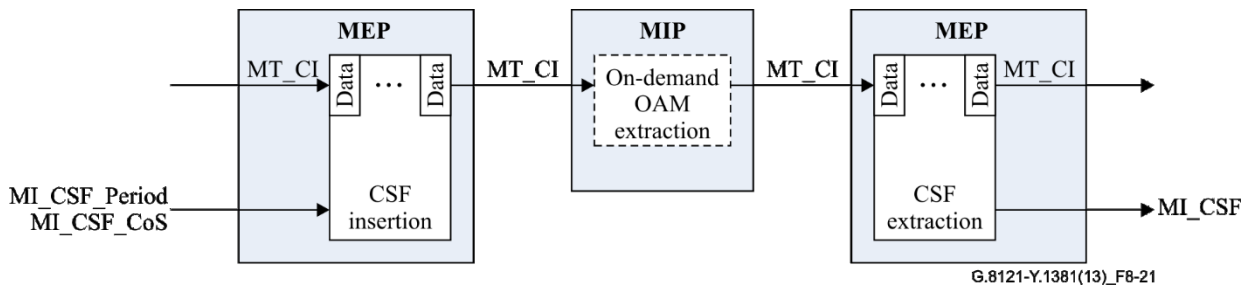




**Figure 8-20/G.8121/Y.1381 – APS Extract Behaviour**

### 8.7.3 CSF Insert and Extract Processes

Figure 8-21 shows the different processes inside MEPs and MIPs that are involved in the CSF<sup>5</sup> Protocol.



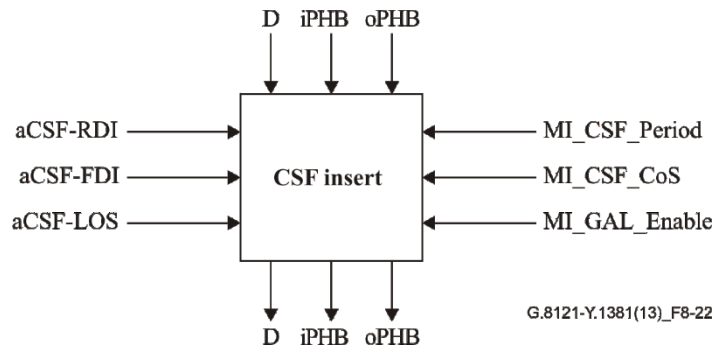
**Figure 8-21/G.8121/Y.1381 – Overview of Processes involved with CSF Protocol**

The MPLS-TP Client Signal Fail function (MT-CSF) is used by a MEP to propagate to a peer MEP the detection of a failure or defect event in an MPLS-TP client signal when the client itself does not support appropriate fault or defect detection or propagation mechanisms, such as MT-CC or MT-AIS. The MT-CSF messages propagate in the direction from MPLS-TP MEP function detecting the failure or defect event to the MPLS-TP sink-adaptation function associated with the peer MEP.

MT-CSF generation is located at MT/Client\_A\_So to insert CSF traffic unit and ProActive OAM Insertion is located at MT\_TT.

IETF uses the term “Client Failure Indication” for this function in [IETF RFC 6371]

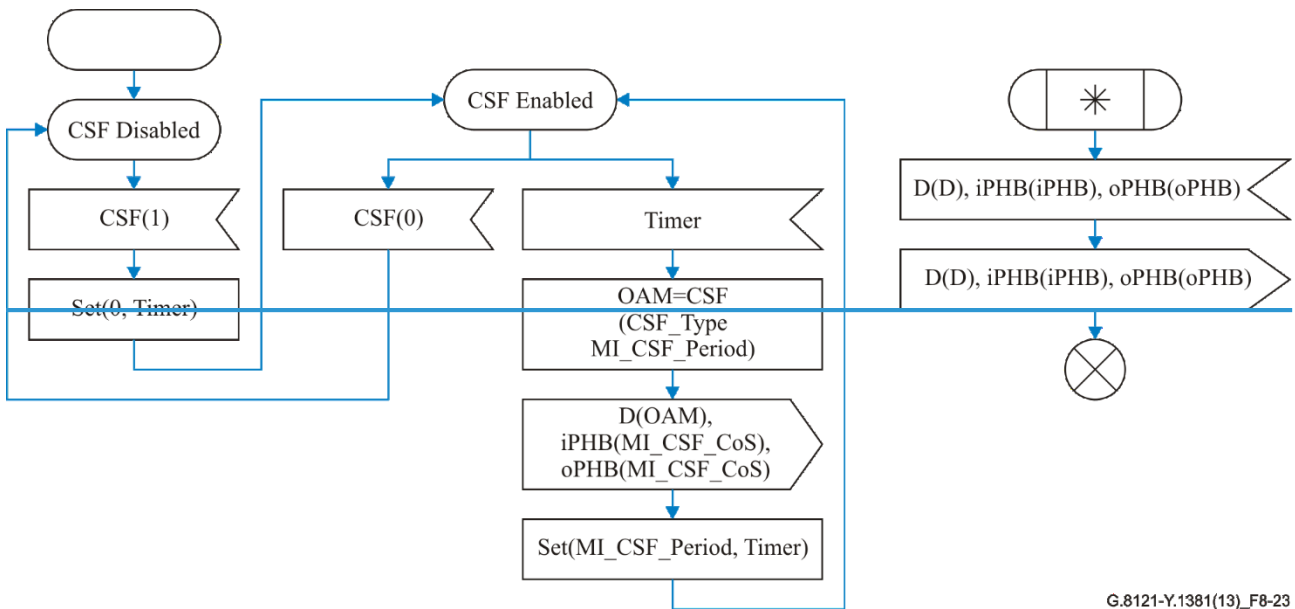
### 8.7.3.1 CSF Insert Process

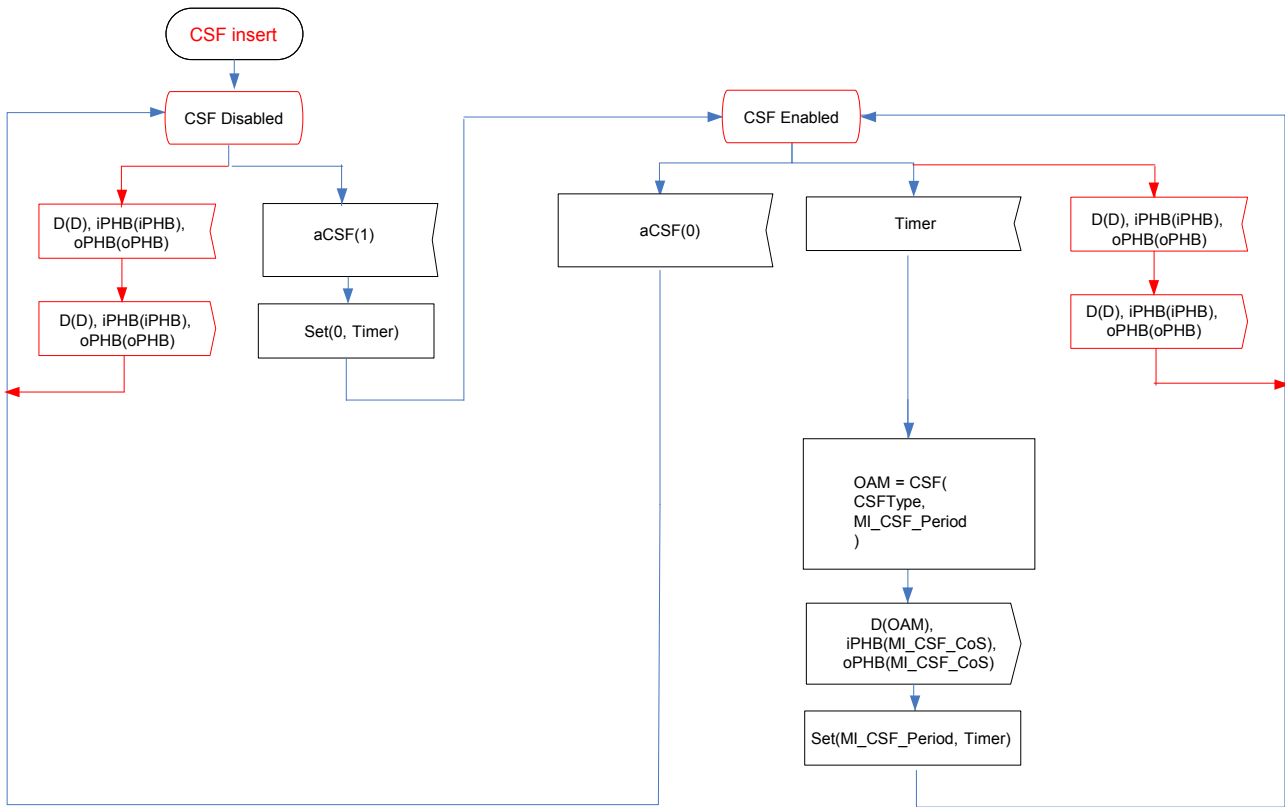


**Figure 8-22/G.8121/Y.1381 – CSF Insert process**

The CSF Insert Process is located at MT/Client\_A\_So as a part of CSF generation. Figure 8-22 shows the CSF Insert Process Symbol and Figure 8-23 defines the behaviour. If the aCSF signal is true, the CSF Insert process periodically generates MT\_CI traffic units where the MT\_CI\_D signal contains the CSF signal until the aCSF signal is false. The generated CSF traffic units are inserted in the incoming stream, i.e., the output stream contains the incoming traffic units and the generated CSF traffic unit that contains G-ACh traffic unit as described in Clause 8.1 which includes GAL or not depending on MI\_GAL\_Enable. The period between consecutive CSF traffic units is determined by the MI\_CSF\_Period parameter.

The specific CSF traffic unit is for further study.

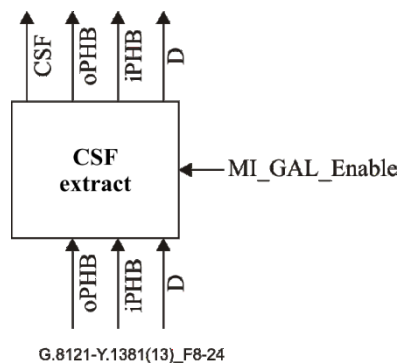




**Figure 8-23/G.8121/Y.1381 – CSF Insert behaviour**

Note: generation of CSF(0) and CSF(1) events as well as determination of CSF type is for further study

### 8.7.3.2 CSF Extract Process



**Figure 8-24/G.8121/Y.1381 – CSF Extract process**

The CSF Extract process is located at MT/Client\_A\_sk and extracts MT-CSF from MI\_AI\_D. Figure 8-24 shows the CSF Extract Process Symbol.

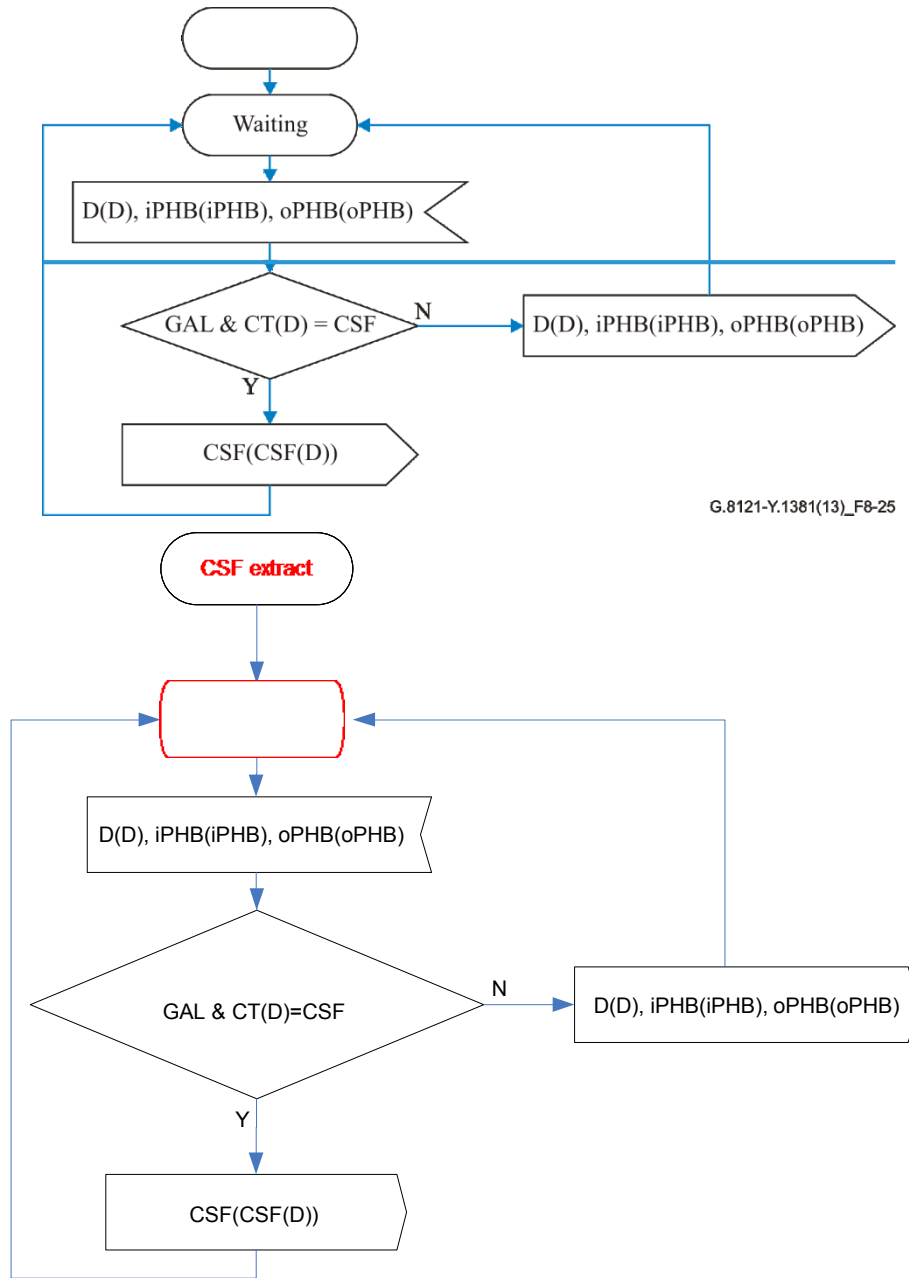
The encoding of the MT\_CI\_D signal for CSF [packtesframes](#) is for further study.

The criteria for filtering are based on the values of the fields within the MT\_CI\_D signal:

- GAL included to the MT\_CI\_D if GAL usage is enabled via MI\_GAL\_Enable
- OAM type that is defined in Channel type of G-ACh indicates CSF

This behaviour is defined in Figure 8-25. The function CSF(D) extracts the CSF specific information from the received Traffic Unit.

Note: The G-ACh process is carried out as defined in clause 8.1. The CSF traffic unit in MT\_CI\_D is forwarded to the CSF extract process.



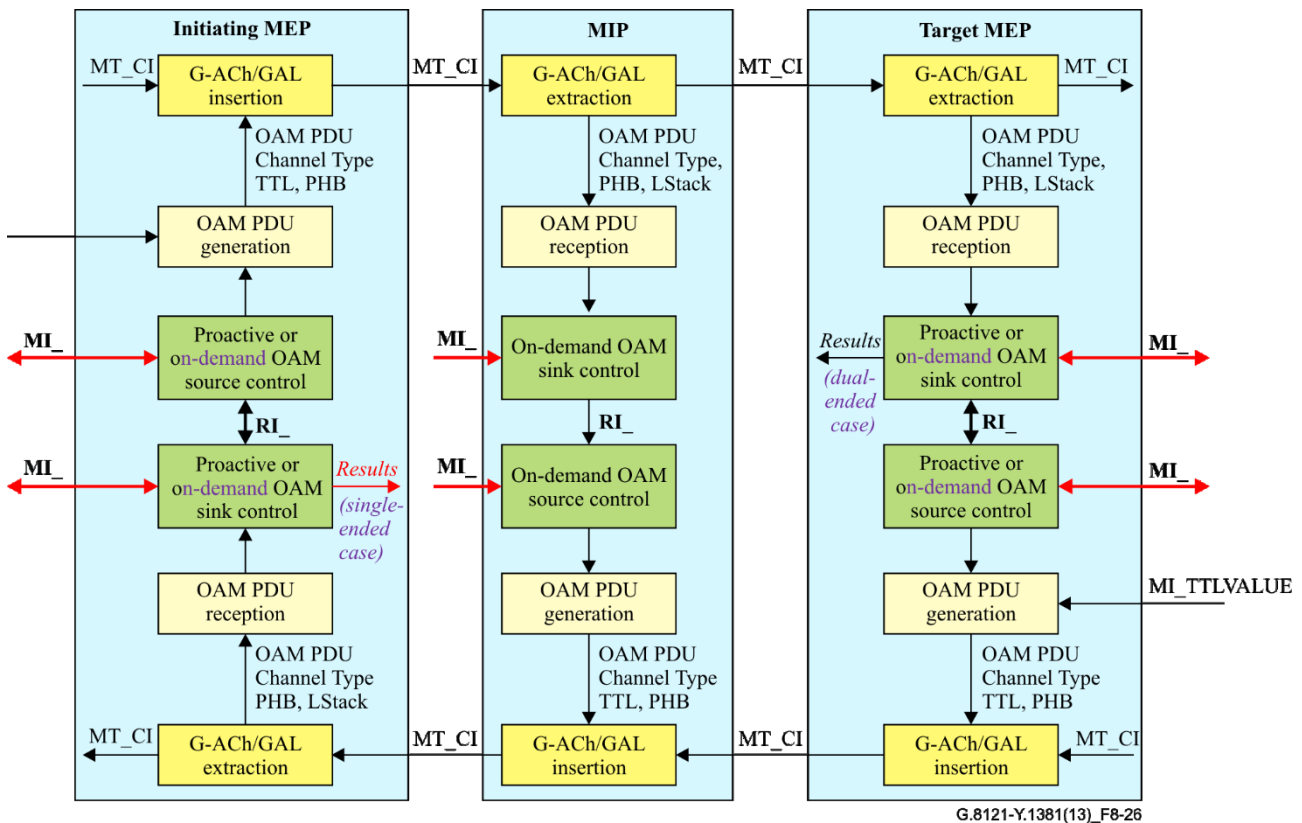
**Figure 8-25/G.8121/Y.1381 – CSF Extract Behaviour**

## 8.8 Proactive and on-demand OAM related Processes

As described in [IETF RFC 6371], OAM functions are categorized as proactive and on-demand and these OAM functionalities provide the different interfaces.

OAM functions can be also categorised as single-ended and dual-ended. Single-ended functions are those in which an initiating MEP sends OAM PDUs to a target MEP, which processes it and sends a response OAM PDU back to the initiating MEP. The results of the function are available only on the initiating MEP. Dual-ended functions are those in which an initiating MEP sends OAM PDUs to a target MEP, which processes it and does not send a response. The results of the function are available only on the target MEP. Dual-ended functions are typically deployed in pairs, one in each direction.

Figure 8-26 shows an OAM protocol-neutral abstract model of the different processes inside MEPs and MIPs that are involved in performing single-ended proactive or on-demand OAM functions. In the case of dual-ended functions, the model is equivalent to the top half of the diagram only, and the results are reported by the OAM sink control process on the Target MEP.



**Figure 8-26/G.8121/Y.1381 – Overview of the processes involved with proactive or on-demand OAM functions**

NOTE – The MT\_CI signals at the input of the G-ACh Insertion process and at output of the G-ACh Extraction process are not input/output signals of the Initiation/Target MEPs but signals which are internal to these MEPs.

The processes shown in Figure 8-26 are described further below, with the exception of the G-ACh Insertion and Extraction processes which are described in clause 8.1.

The relevant Management Information (MI) and Remote Information (RI) used by these processes depend on the OAM function to be performed and is defined in the following sub-clauses.

The detailed specification of all the OAM processes, including further process decomposition and the interface between them, is OAM protocol-specific and therefore outside the scope of this Recommendation.

### **OAM Control Processes:**

The four OAM Control Processes (that is, the Proactive OAM Source Control process, Proactive OAM Sink Control process, On-demand OAM Source Control process and On-Demand OAM Sink Control process) perform all the OAM control procedures (e.g., they maintain the necessary state machine) that are required for a specific OAM protocol. The proactive OAM source and sink control processes operate within the MT\_TT\_So and MT\_TT\_Sk atomic functions respectively.

Similarly, the On-demand OAM Source and Sink Control processes operate within the MTDe\_TT\_So or MTDi\_TT\_So and the MTDe\_TT\_Sk or MTDi\_TT\_Sk atomic functions respectively.

All four processes consist of a number of OAM protocol-specific control sub-processes, each relating to a different OAM function. The details of these sub-processes are outside the scope of this recommendation

The OAM Source Control process within the initiating MEP (Proactive or On-demand as appropriate) requests the OAM PDU Generation process to generate OAM Request PDUs toward the target MEP on the basis of the local state machine and the relevant Management Information (MI\_). This supports both single-ended and dual-ended OAM transactions.

In the case of a dual-ended OAM transaction, the appropriate OAM Sink Control process within the target MEP (Proactive or On-demand) or within the target MIP (On-demand only) reports the dual-ended OAM results on the basis of the OAM Request PDUs received by the OAM PDU Reception process.

In the case of single-ended OAM transactions, the following actions are taken:

- The OAM Sink Control process within the target MEP or MIP provides the local OAM Source Control process the relevant Remote Information (RI\_) to generate a reply to the OAM Request PDU received by the local PDU Reception process.
- The OAM Source Control process within the target MEP or MIP requests the OAM PDU Generation process to generate OAM Reply PDUs toward the initiating MEP based on the information it receives from the local OAM Sink Control process via the relevant Remote Information (RI\_).
- The OAM Sink Control process within the initiating MEP reports the unidirectional or bidirectional OAM results based on the OAM Reply PDUs received by the local OAM PDU Reception process

### **OAM PDU Generation process:**

The OAM PDU Generation process builds, when instructed by its control process, the required OAM PDU and passes it to the G-ACh Insertion process, defined in clause 8.1, for insertion within the MPLS-TP CI traffic flow. It also passes the following information elements that are required by the G-ACh Insertion process: the PHB associated to the OAM packet (on the basis of the CoS instruction received by the control process); the ACh Channel Type that identifies the OAM PDU and the TTL value which it is either the TTL distance to a MIP (for OAM PDUs targeted to a MIP and properly requested by the control process) or the default value as configured via MI\_TTLValue.

The OAM PDU generation process consists of a number of OAM protocol-specific PDU generation sub-processes (one for each PDU type) and a sub-process that multiplexes all the PDUs generated by these OAM protocol-specific PDU generation sub-processes into a single stream of OAM PDUs,



which is sent to the G-ACh Insertion process along with the appropriate ACH Channel Type. The details of these sub-processes are outside the scope of this recommendation.

### **OAM PDU Reception process:**

The OAM PDU Reception process receives an OAM PDU, together with the ACH Channel Type value identifying the PDU type, the associated PHB, and the label stack (LStack) data, from the G-ACh process and passes the relevant information to its control process.

The OAM PDU Reception process consists of a number of OAM protocol-specific PDU reception sub-processes (one for each PDU type) and a sub-process that demultiplexes OAM PDUs received from the G-ACh Extraction process towards these OAM protocol-specific PDU reception sub-processes based on the ACH Channel Type. The details of these sub-processes are outside the scope of this recommendation.

### **8.8.1 Proactive Continuity Check and Connectivity Verification (CC/CV)**

As described in [IETF RFC 6371], both CC and CV OAM functions are based on the proactive generation of OAM packets by the source MEP that are processed by the peer sink MEP(s).

The source MEP generates CC/CV OAM packets if it is enabled via Management Information. As described in [IETF RFC 6371], the CC/CV OAM packets are generated at a regular rate which is configured by the operator via the MI\_CC\_Period. These packets are also transmitted using PHB which is configured via MI\_CC\_CoS (and that is typically the “minimum loss probability PHB”).

In order to perform Connectivity Verification, the generated CC/CV packets also includes a globally unique Source MEP identifier: the transmitted value is configured via protocol-specific management information on the source MEP while the expected value is configured via different protocol-specific management information on the sink MEP.

The sink MEP always processes received CC/CV OAM packets and detects the following CC/CV defects, as defined in clause 6.1:

- dLOC
- dUNC
- dMMG
- dUNM
- dUNP

CC/CV OAM packets pass transparently through MIPs as described in [IETF RFC 6371].

The EMF can retrieve from the sink MEP the latest CC/CV OAM packet which caused a defect condition via the MI\_Get\_SvdCC command: the CC/CV OAM packet is returned to the EMF via the MI\_SvdCC.

### **8.8.2 Remote Defect Indication (RDI)**

As in [IETF RFC6371], in case of co-routed and associated bidirectional transport paths, RDI is associated with proactive CC/CV, and the RDI indicator can be piggy-backed onto the CC/CV packet.

RDI information is carried in the CC/CV packets based upon the RI\_CC/CV\_RDI input. It is extracted in the CC/CV Reception Process.

In case of unidirectional transport paths, the RDI related OAM process is for further study.

### 8.8.3 On-demand Connectivity Verification (CV)

As described in [IETF RFC 6371], on-demand CV OAM functions are based on the on-demand generation of OAM packets by the source MEP, that are processed and responded to by the peer sink MIP(s) or MEP(s).

The source MEP generates on-demand CV OAM packets when requested via protocol-specific MI signals. The results of the on-demand CV operation are returned by the source MEP using additional protocol-specific management information.

### 8.8.4 Proactive Packet Loss Measurement (LMp)

As described in [IETF RFC 6371], proactive LM is performed by periodically sending LM OAM packets from the initiating MEP to the target MEP and by receiving LM OAM packets from the target MEP on a co-routed bidirectional connection. Each MEP performs measurements of its transmitted and received user data packets (TxFCI and RxFCI). These measurements are then correlated in real time with the target MEP in the ME to derive the impact of packet loss on a number of performance metrics for the ME in the MEG.

[As described in \[IETF RFC 6374\], there are two types of LM mechanism. One is to directly measure data-plane packet loss by counting packets transmitted and received. This is called LM or direct LM. The other is to measure the approximate data-plane loss level by counting synthetic packets transmitted and received. This is called synthetic loss measurement \(SLM\) or inferred loss measurement.](#)

For single-ended measurement:

- The initiating MEP generates proactive LM OAM Request packets if MI\_LMp\_Enable is true. These packets are generated at the rate configured via the MI\_LMp\_Period and, as described in [IETF RFC 6371], with the PHB configured via MI\_LMp\_CoS that yields the lowest drop precedence within the measured PHB Scheduling Class, in order to maximize reliability of measurement within the traffic class. The local value of transmitted user data packets (TxFCI) is inserted within the LM OAM packet by the OAM PDU Generation process.
- The target MEP replies to the LM OAM packets if it is enabled. The local value of the received user data packets (RxFCI) at the time the proactive LM OAM Request packet has been received is passed by OAM PDU Reception process to the proactive OAM sink control process, then to the proactive OAM source control process (via RI\_OAM\_Info) and inserted by the OAM PDU Generation process within the transmitted proactive LM OAM Reply: the actual behaviour on how this information is passed is OAM protocol specific and therefore outside the scope of this Recommendation. The OAM PDU Generation process also inserts the local value of the transmitted user data packets (TxFCI) in the reverse direction within the transmitted proactive LM OAM Reply.
- The initiating MEP processes the received proactive LM OAM Reply packet, together with the local value of the received used data packets (RxFCI) in the reverse direction at the time this OAM packet is received, as passed by the OAM PDU Reception process, and generates LM results.

— Depending on the LMp OAM tool that it is used, the LM results can be either calculated by the proactive OAM sink control process or by the proactive OAM source control process. In the latter case, the the proactive OAM sink control process passes the required information in the received LM OAM Reply to the the proactive OAM source control process via the RI\_LMRp and receives the LM results back via the RI\_LMp\_Result. In both cases, the proactive OAM sink control process passes the LM Results to the relevant performance monitoring processes within the MT\_TT\_Sk atomic function for reporting to the EMF that is described in [b-ITU-T G.8151]. [Note: The behaviour is the same when synthetic proactive \(SLp\) LM is used. In this Recommendation, the term SLp is used to address the management and remote information \(MI and RI\) for synthetic loss measurement.](#)

For dual-ended measurement:

- The initiating MEP generates proactive LM OAM Request packets ~~if it is enabled to do so via management information.~~ [if MI\\_1LMp\\_Enable is true.](#) These packets are generated at the rate configured via the MI\_LMp\_Period and, as described in [IETF RFC 6371], with the PHB configured via MI\_LMp\_CoS that yields the lowest drop precedence within the measured PHB Scheduling Class, in order to maximize reliability of measurement within the traffic class. The local value of transmitted user data packets (TxFCI) is inserted within the LM OAM packet by the OAM PDU Generation process.
- The target MEP receives LM OAM packets if it is enabled to do so via management information. The local value of the received user data packets (RxFCI) at the time the proactive LM OAM Request packet has been received is passed by OAM PDU Reception process to the proactive OAM sink control process and generates LM results. [Note: The behaviour is the same when dual-ended synthetic proactive \(1SLp\) LM is used. In this Recommendation, the term 1SLp is used to address the management and remote information \(MI and RI\) for synthetic loss measurement.](#)

Proactive LM OAM packets pass transparently through MIPs as described in [IETF RFC 6371].

### 8.8.5 On-demand Packet Loss Measurement (LMo)

As described in [IETF RFC 6371], on-demand LM is performed by the command that sends LM OAM packets from the initiating MEP to the target MEP and by receiving LM OAM packets from the target MEP on a co-routed bidirectional connection. The initiating MEP performs measurements of its transmitted and received user data packets (TxFCI and RxFCI). These measurements are then correlated in real time with values received from the target MEP in the ME to derive the impact of packet loss for the ME in the MEG.

[As described in \[IETF RFC 6374\], there are two types of LM mechanism. One is to directly measure data-plane packet loss by counting packets transmitted and received. This is called LM or direct LM. The other is to measure the approximate data-plane loss level by counting synthetic packets transmitted and received. This is called synthetic loss measurement \(SLM\) or inferred loss measurement.](#)

For single-ended measurement:

- The initiating MEP generates on-demand LM OAM Request packets when enabled via management information. These packets are generated with the PHB configured via management information that yields the lowest drop precedence within the measured PHB Scheduling Class, in order to maximize reliability of measurement within the traffic class. The local value of

transmitted user data packets (TxFCI) is inserted within the LM OAM packet by the OAM PDU Generation process.

- The target MEP replies to the LM OAM packets if enabled via management information. The local value of the received user data packets (RxFCI) at the time the on-demand LM OAM Request packet has been received is passed by OAM PDU Reception process to the on-demand OAM sink control process, then to the on-demand OAM source control process (via RI\_OAM\_Info) and inserted by the OAM PDU Generation process within the transmitted on-demand LM OAM Reply: the actual behaviour on how this information is passed is OAM protocol specific and therefore outside the scope of this Recommendation. The OAM PDU Generation process also inserts the local value of the transmitted user data packets (TxFCI) in the reverse direction within the transmitted on-demand LM OAM Reply.
- The initiating MEP processes the received on-demand LM OAM Reply packet, together with the local value of the received user data packets (RxFCI) in the reverse direction at the time this OAM packet is received, as passed by the OAM PDU Reception process, and generates LM results.
- Depending on the LMo OAM tool that it is used, the LM results can be either calculated by the on-demand OAM sink control process or by the on-demand OAM source control process. In both cases, ~~the LM results are reported to EMF by the MTDe\_TT\_So by the protocol specific management information.~~ the LM results are reported to EMF by the MTDe\_TT\_So using the MI\_LMo\_Result(N\_TF,N\_LF,F\_TF,F\_LF) signal, containing the near-end transmitted packets, near-end lost packets, far-end transmitted packets and far-end lost packets.

Note: The behaviour is same when synthetic on-demand (SLo) LM is used. In this Recommendation, the term SLo is used to address the management and remote information (MI and RI) for synthetic loss measurement.

For dual-ended measurement:

- The initiating MEP generates on-demand LM OAM Request packets when enabled via management information. These packets are generated at the rate configured via the MI\_LMo\_Period and, as described in [IETF RFC6371], with the PHB configured via MI\_LMo\_CoS that yields the lowest drop precedence within the measured PHB Scheduling Class, in order to maximize reliability of measurement within the traffic class. The local value of transmitted user data packets (TxFCI) is inserted within the LM OAM packet by the OAM PDU Generation process.
- The target MEP receives LM OAM packets when enabled via management information. The local value of the received user data packets (RxFCI) at the time the on-demand LM OAM Request packet has been received is passed by OAM PDU Reception process to the on-demand OAM sink control process and generates LM results.

On demand LM OAM packets pass transparently through MIPs as described in [IETF RFC6371].

### 8.8.6 Proactive Packet Delay Measurement (DMp)

As described in [IETF RFC6371], proactive DM is performed by periodically sending DM OAM packets from the initiating MEP to the target MEP and by receiving DM OAM packets from the target MEP on a co-routed bidirectional connection. Each MEP records its transmitted and received Timestamps. The timestamps from the initiating and target MEPs are then correlated to derive a number of performance metrics relating to delay for the ME in the MEG.

For single-ended measurement:

- The initiating MEP generates proactive DM OAM Request packets if MI\_DMp\_Enable is true. These packets are generated at the rate configured via the MI\_DMp\_Period and, as described in [IETF RFC 6371], with the PHB configured via MI\_DMp\_CoS that yields the lowest drop precedence within the measured PHB Scheduling Class, in order to maximize reliability of measurement within the traffic class. The local value of transmitted timestamp (TxTimeStampf) is inserted within the DM OAM packet by the OAM PDU Generation process.
- The target MEP replies to the DM OAM packets if enabled by management information. The local value of the received timestamp (RxTimeStampI) at the time the proactive DM OAM Request packet has been received is passed by OAM PDU Reception process to the proactive OAM sink control process, then to the proactive OAM source control process (via RI\_OAM\_Info) and inserted by the OAM PDU Generation process within the transmitted proactive DM OAM Reply: the actual behaviour on how this information is passed is OAM protocol specific and therefore outside the scope of this Recommendation. The OAM PDU Generation process also inserts the local value of the transmitted timestamp (TxTimeStampf) in the reverse direction within the transmitted proactive DM OAM Reply.
- The initiating MEP processes the received proactive DM OAM Reply packet, together with the local value of the received timestamp (RxTimeStampI) in the reverse direction at the time this OAM packet is received, as passed by the OAM PDU Reception process, and generates DM results.
- Depending on the DMp OAM tool that it is used, the DM results can be either calculated by the proactive OAM sink control process or by the proactive OAM source control process. In the latter case, the proactive OAM sink control process passes the required information in the received DM OAM Reply to the proactive OAM source control process via the RI\_DMpRp and receives the DM results back via the RI\_DMp\_Result. In both cases, the proactive OAM sink control process passes the DM Results to the relevant performance monitoring processes within the MT\_TT\_Sk atomic function for reporting to the EMF.

For dual-ended measurement:

- The initiating MEP generates proactive DM OAM Request packets [if MI\\_1DMp\\_Enable is true, if enabled by management information](#). These packets are generated at the rate configured via the MI\_DMp\_Period and, as described in [IETF RFC 6371], with the PHB configured via MI\_DMp\_CoS that yields the lowest drop precedence within the measured PHB Scheduling Class, in order to maximize reliability of measurement within the traffic class. The local value of transmitted Timestamp (TxTimeStampI) is inserted within the DM OAM packet by the OAM PDU Generation process.
- The target MEP receives DM OAM packets if enabled by management information. The local value of the received Timestamp (RxTimeStampI) at the time the proactive DM OAM Request packet has been received is passed by OAM PDU Reception process to the proactive OAM sink control process which generates DM results.

Proactive DM OAM packets pass transparently through MIPs as described in [IETF RFC 6371].

### 8.8.7 On-demand Packet Delay Measurement (DMo)

As described in [IETF RFC6371], on-demand DM is performed by the command that sends DM OAM packets from the initiating MEP to the target MEP and by receiving DM OAM packets from the target MEP on a co-routed bidirectional connection. Each MEP records its transmitted and received Timestamps. The timestamps from the initiating and target MEPs are then correlated to derive a number of performance metrics relating to delay for the ME in the MEG.

For single-ended measurement:

- The initiating MEP generates on-demand DM OAM Request packets if MI\_DMo\_Enable is true. These packets are generated with the PHB configured via MI\_DMo\_CoS that yields the lowest drop precedence within the measured PHB Scheduling Class, in order to maximize reliability of measurement within the traffic class. The local value of transmitted timestamp (TxTimeStampf) is inserted within the DM OAM packet by the OAM PDU Generation process.
- The target MEP replies to the PM OAM packets if the MI\_PMo\_Enable is true. The local value of the received timestamp (RxTimeStampf) at the time the on-demand PM OAM Request packet has been received is passed by OAM PDU Reception process to the on-demand OAM sink control process, then to the on-demand OAM source control process (via RI\_OAM\_Info) and inserted by the OAM PDU Generation process within the transmitted on-demand DM OAM Reply: the actual behaviour on how this information is passed is OAM protocol specific and therefore outside the scope of this Recommendation.
- The initiating MEP processes the received on-demand DM OAM Reply packet, together with the local value of the received timestamp (RxTimestampf) in the reverse direction at the time this OAM packet is received, as passed by the OAM PDU Reception process, and generates DM results.
- Depending on the DMO OAM tool that it is used, the DM results can be either calculated by the on-demand OAM sink control process or by the on-demand OAM source control process. In both cases, the DM results are reported to EMF by the MTDe TT So using the MI\_DMo\_Result(B\_FD[],F\_FD[],N\_FD[]) signal, containing the count of measurements, and arrays of round-trip frame delay, far-end frame delay and near-end frame delay measurements~~the DM results are reported to EMF by the MTDe TT So by the protocol-specific management information.~~

For dual-ended measurement:

- The initiating MEP generates on-demand DM OAM Request packets if MI\_DMo\_Enable is true. These packets are generated at the rate configured via the MI\_DMo\_Period and, as described in [IETF RFC6371], with the PHB configured via MI\_DMo\_CoS that yields the lowest drop precedence within the measured PHB Scheduling Class, in order to maximize reliability of measurement within the traffic class. The local value of transmitted Timestampf (TxTimestampf) is inserted within the DM OAM packet by the OAM PDU Generation process.
- The target MEP receives DM OAM packets if the MI\_DMo\_Enable is true. The local value of the received Timestampf (RxTimestampf) at the time the on-demand DM OAM Request packet has been received is passed by OAM PDU Reception process to the on-demand OAM sink control process and generates DM results.

On-demand DM OAM packets pass transparently through MIPs as described in [IETF RFC 6371].

### 8.8.8 Throughput Test

For dual-ended Throughput Test:

- As described in [IETF RFC 6371], out of service on demand throughput estimation can be performed by sending OAM test packets at increasing rate (up to the theoretical maximum), computing the percentage of OAM test packets received and reporting the rate at which OAM test packets begin to drop. In general, this rate is dependent on the OAM test packet size.
- The source MEP starts generating test packets when requested via protocol-specific management information and continues generating these packets at the configured period until requested to

stop; at this time the number of sent packets is reported via protocol-specific management information.

- The sink MEP, when enabled via protocol-specific management information, starts processing the received OAM test packets until the test is terminated; at this time, the calculated test results are reported.

For single-ended Throughput Test:

- For further study

### **8.8.9 Route Tracing (RT)**

For further study

### **8.8.10 LCK/AIS Reception**

As described in [IETF RFC6371], when a MEP detects a signal fail condition or is locked, it may transmit AIS or lock messages at the client layer, respectively. These are transmitted by the AIS Insert Process (see Clause 8.6.2) or the LCK Generate Process (see Clause 8.6.3), and are received by the LCK/AIS Reception sub-process in the Proactive OAM Sink Control process. The receipt of AIS or lock message triggers the dAIS or dLCK defects respectively, as described in Clause 6.1.

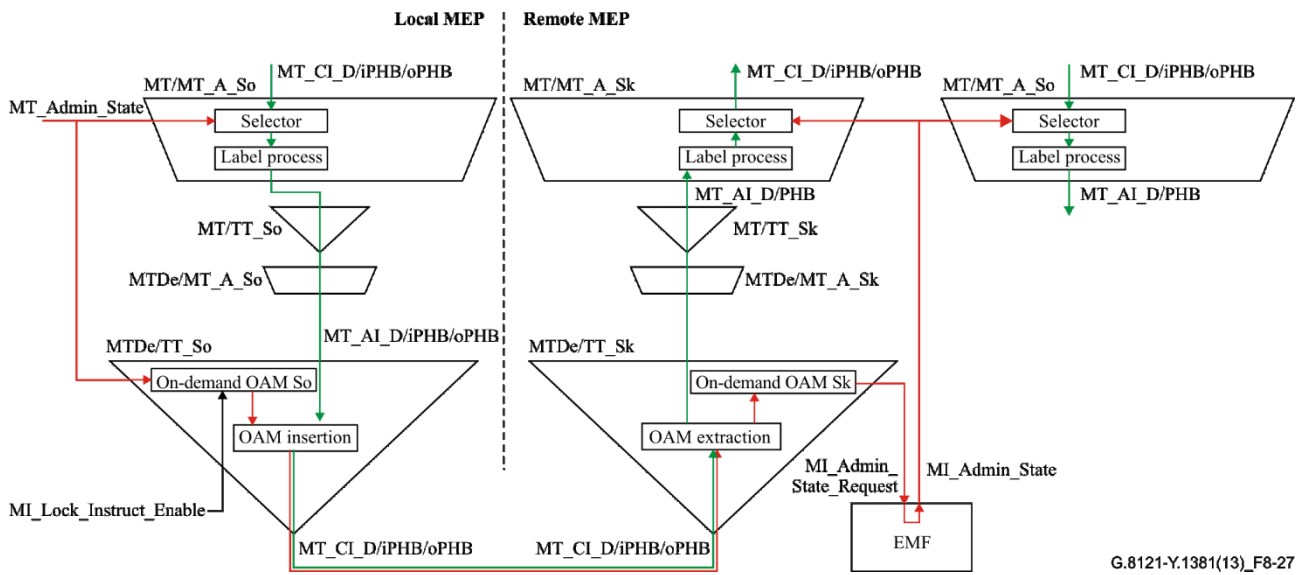
### **8.8.11 Lock Instruct processes**

As described in [RFC 6371], when a MEP is administratively locked, it puts the local MPLS-TP trail into a locked state and, if enabled by the MI\_Lock\_Instruct\_Enable, it also starts transmitting a lock instruct message to its peer MEP. The locking of the trail at the local MEP is performed by the Selector process defined in clause 8.6.1; the transmission of lock instruct (LKI) messages is performed by the On-demand OAM process.

On receiving an LKI message, the peer MEP must also lock the path.

The lock instruct message is received by the On-demand OAM process and the request is signalled to the EMF via MI\_Admin\_State\_Request. The EMF should then combine this remote request with any local request from the user, and set MI\_Admin\_State accordingly in the corresponding MT/MT\_A\_So and MT/MT\_A\_Sk processes.

The figure below illustrates how setting MI\_Admin\_State on the local MEP both locks the local Selector processes (the local Selector in the MT/MT\_A\_Sk is not shown), and triggers the generation of LKI messages to the remote MEP that cause the two remote Selector processes to also be locked.



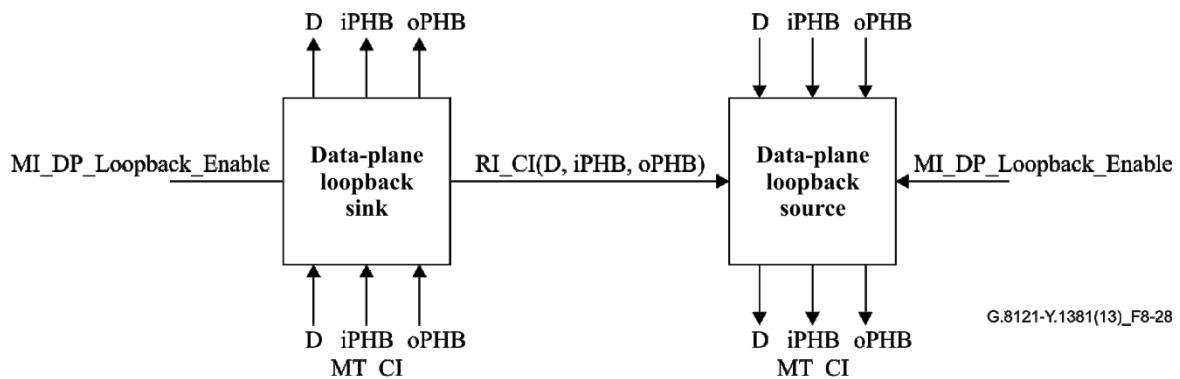
**Figure 8-27/G.8121/Y.1381 – Overview of the processes involved with Lock Instruct**

Note: it is important that the remote MEP is locked as soon as possible after receiving the first Lock Instruct message; therefore the EMF must handle the MI\_Admin\_State\_Request with high priority to ensure it is reflected in MI\_Admin\_State as quickly as possible.

Note: the EMF must combine any local lock request from the user with the received MI\_Admin\_State\_Request, when setting MI\_Admin\_State in the MT/MT\_A\_So and MT/MT\_A\_Sk functions. However, when setting MI\_Admin\_State in the MTDe\_TT\_So function, the EMF must only do so based on a local request from the user. This is to prevent a deadlock situation where receipt of a lock instruct message causes transmission of a lock instruct message in the opposite direction.

### 8.9 Dataplane Loopback Processes

As described in [RFC 6435], the dataplane loopback process control looping back of all traffic (ie both Data and OAM frames/packets), under management control. An overview is shown on Figure 8-29.



**Figure 8-29/G.8121/Y.1381 – Overview of the processes involved with Dataplane Loopback**

Note: The dataplane loopback processes are included in the MEP Diagnostic Trail Termination function (MTDe\_TT, see 9.4.1.1) and the MIP Diagnostic Trail Termination function (MTDi\_TT, see 9.4.2.1). Dataplane Loopback may also be enabled on a transport path at a point where there is no MEP or MIP; the location of the dataplane loopback processes in this case is for further study.



### 8.9.1 Dataplane Loopback Sink Processes

The Dataplane Loopback Sink process is described by Figure 8-30.

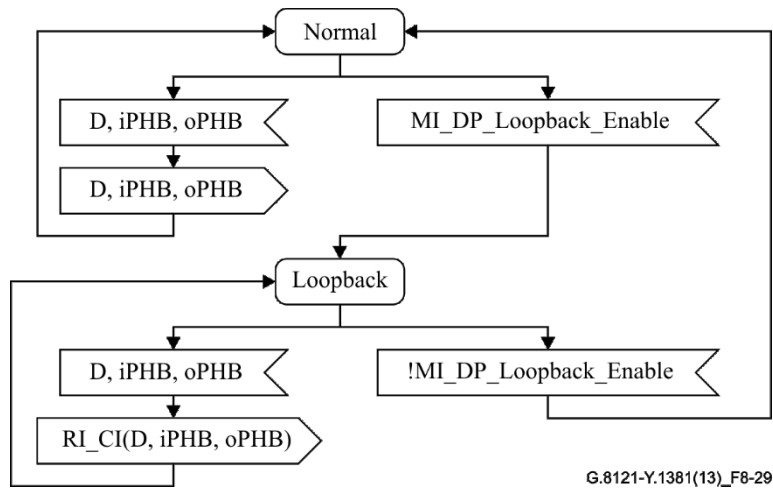


Figure 8-30/G.8121/Y.1381 – Dataplane Loopback Sink process

In Normal state, data traffic passes through the process unmodified; in Loopback state, it is intercepted and sent to the Dataplane Loopback Source process via RI\_CI.

### 8.9.2 Dataplane Loopback Source Processes

The Dataplane Loopback Source process is described by Figure 8-31.

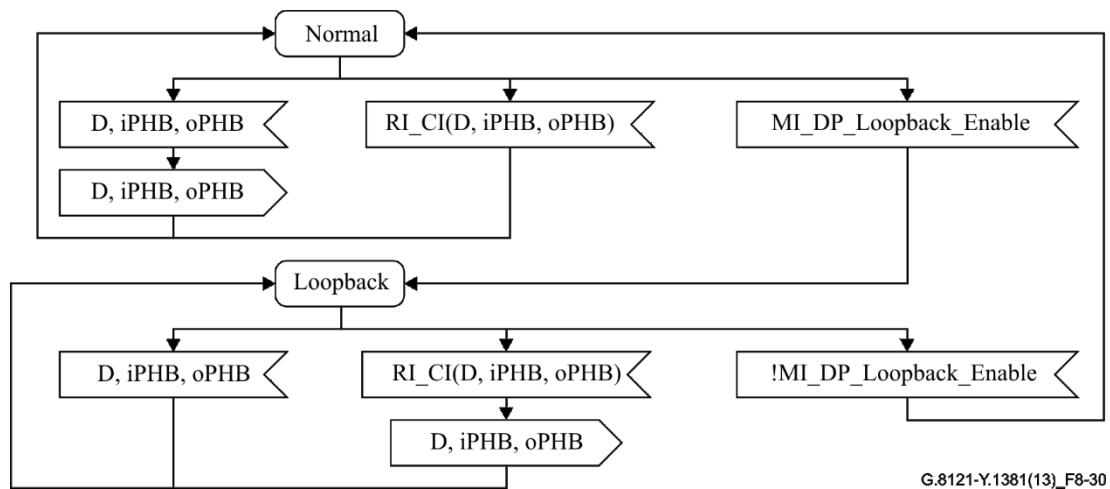


Figure 8-31/G.8121/Y.1381 – Dataplane Loopback Source process

In Normal state, data traffic passes through the process unmodified; in Loopback state, data traffic is dropped, and data received via RI\_CI from the Dataplane Loopback Sink process is transmitted instead.

## 9 MPLS-TP layer functions

Figure 9-0 illustrates the MPLS-TP layer network and server and client layer adaptation functions. The information crossing the MPLS-TP connection point (MT\_CP) is referred to as the MPLS-TP characteristic information (MT\_CI), and consists of:

- MT\_CI\_D (containing the 'S' bit, TTL, and MPLS payload)
- MT\_CI\_iPHB
- MT\_CI\_oPHB
- MT\_CI\_SSF
- MT\_CI\_APS
- MT\_CI\_LStack

These are described in clause 6.1.2/G.8110.1 except for MT\_CI\_LStack, which contains a copy of the complete label stack received from the network.

The information crossing the MPLS-TP access point (MT\_AP) is referred to as the MPLS-TP adapted information (MT\_AI), and consists of:

- MT\_AI\_D (containing the 'S' bit and MPLS payload)
- MT\_AI\_PHB
- MT\_AI\_TSF
- MT\_AI\_TSD
- MT\_AI\_AIS
- MT\_AI\_LStack

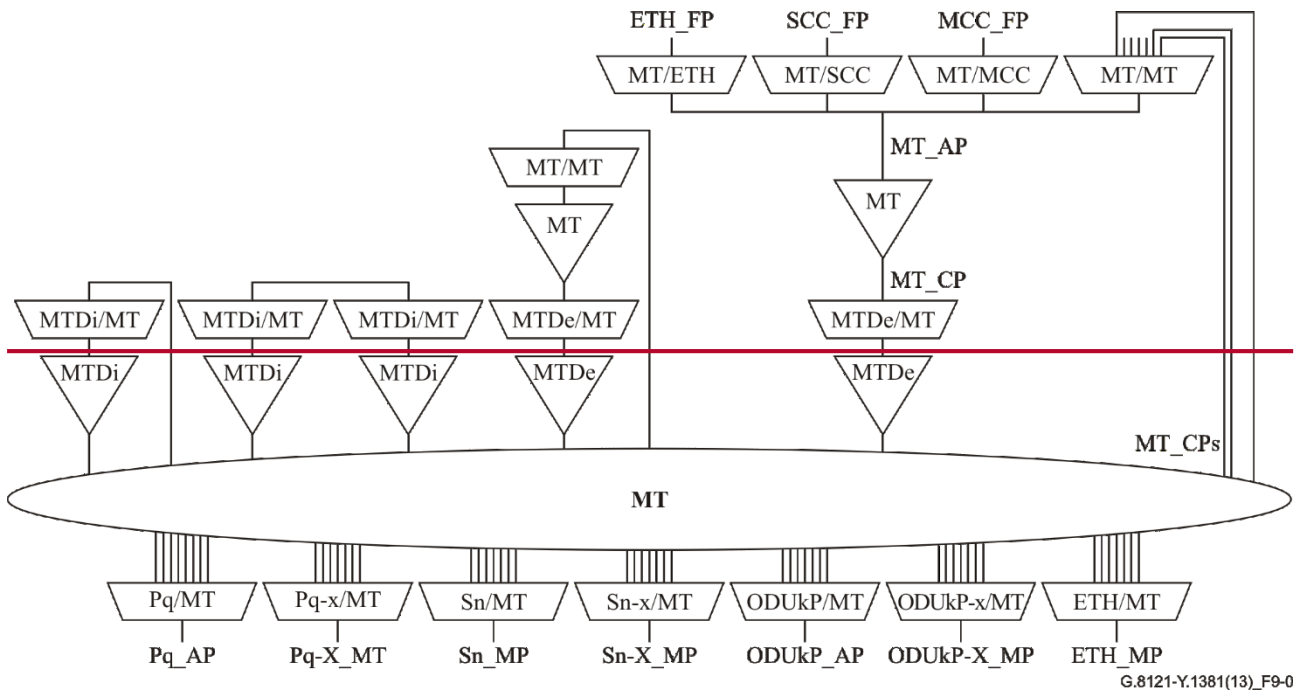
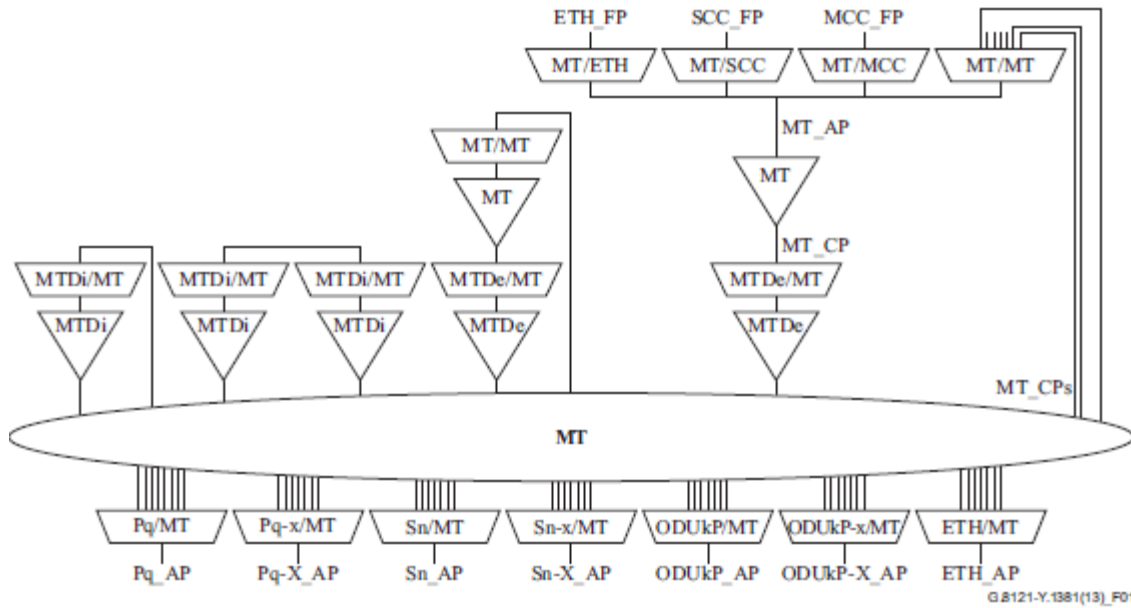
These are described in clause 6.1.1/G.8110.1 except for MT\_AI\_LStack, which is as above, and MT\_AI\_AIS, which indicates an Alarm Indication Signal (AIS) condition.

The information crossing the MPLS-TP diagnostic access points (MTDe\_AP and MTDi\_AP) is referred to as MPLS-TP diagnostic adapted information (MTDe\_AI and MTDi\_AI respectively). These both consist of the same signals, with the same definitions, as MT\_CI.

Note: MTDe\_AI and MTDi\_AI are not the same as MT\_AI. In particular, MTDe\_AI\_D and MTDi\_AI\_D contain a TTL field (whereas MT\_AI\_D does not); and MTDe\_AI and MTDi\_AI contain separate iPHB and oPHB signals (whereas MT\_AI contains a single PHB signal).

The MPLS-TP layer network provides embedded hierarchy via the label stacking mechanism. This is represented in the model by MPLS-TP Tunnel sublayers, which contain MT\_TT and MT/MT\_A functions. The figure shows a generic example for the connection of the MPLS-TP Tunnel functions. It is not required to connect them via a MT\_C function; they can be directly inserted without a connection function. It is noted that this recommendation only defines Ethernet for the client of MPLS-TP as MT/ETH adaptation function.

This mechanism (MPLS-TP tunnel sublayers) is also used when sublayer (tandem connection) monitoring is required.



**Figure 9-0/G.8121/Y.1381 – MPLS-TP atomic functions**

[Ed note: The bottom line of “\*\_MP” should be “\*\_AP”.]

## 9.1 Connection Functions (MT\_C)

### 9.1.1 MPLS-TP Connection Function (MT\_C)

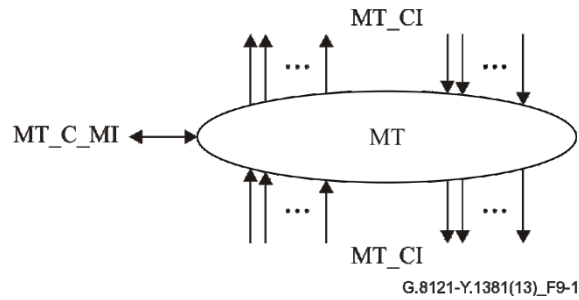
MT\_C is the function that assigns MPLS packets at its input ports to MPLS-TP packets at its output ports.

The MT\_C connection process is a unidirectional function as illustrated in Figure 9-1. The signal formats at the input and output ports of the function are similar, differing only in the logical sequence of the MPLS-TP packets. As the process does not affect the nature of the characteristic

information of the signal, the reference point on either side of the MT\_C function is the same, as illustrated in Figure 9-1.

Incoming MPLS-TP packets at the MT\_CP are assigned to available outgoing MPLS-TP capacity at the MT\_CP. In addition, the MT\_C function supports the SNC/S protection schemes as defined in [ITU-T G.8131]. The Protection functionality is described in clause 9.1.1.19.1.21.

• **Symbol:**



**Figure 9-1/G.8121/Y.1381 – MT\_C symbol**

• **Interfaces:**

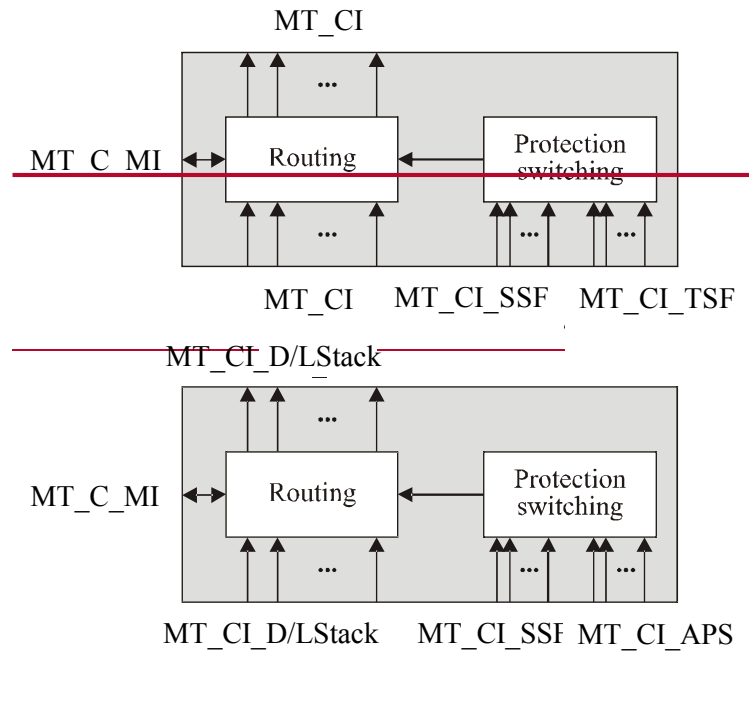
**Table 9-1/G.8121/Y.1381 – MT\_C input and output signals**

Input(s)	Output(s)
<p>—Per MT_CP, n × for the function:            MT_CI_D            MT_CI_iPHB            MT_CI_oPHB            MT_CI_APS            MT_CI_SSF  <del>MT_CI_TSF</del>  <u>MT_CI_SSD (for SNC/S protection)</u>            MT_CI_LStack</p> <p>—per input and output connection point:  <i>for further study</i></p> <p><b>MT_C_MP</b>            MT_C_MI_MatrixControl</p> <p>—<del>P</del>per matrix connection:            MT_C_MI_ConnectionType            MT_C_MI_Return_CP_ID            MT_C_MI_ConnectionPortIds</p> <p>—<del>P</del>per Protection group:              MT_C_MI_PS_WorkingPortId            MT_C_MI_PS_ProtectionPortId            MT_C_MI_PS_ProtType            MT_C_MI_PS_OperType            MT_C_MI_PS_HoTime            MT_C_MI_PS_WTR            MT_C_MI_PS_ExtCMD  <del>MT_C_MI_PS_BridgeType</del>            MT_C_MI_PS_SD_Protection</p>	<p>—per MT_CP, m × per function:            MT_CI_D            MT_CI_iPHB            MT_CI_oPHB            MT_CI_APS            MT_CI_SSF            _MT_CI_LStack</p> <p><u>per Protection group:</u>  <u>MT_C_MI_cFOP-PMb</u>  <u>MT_C_MI_cFOP-PMc</u>  <u>MT_C_MI_cFOP-CM</u>  <u>MT_C_MI_cFOP-NR</u>  <u>MT_C_MI_cFOP-TO</u></p>
<p>↔</p>	

• **Processes:**

In the MT\_C function MPLS-TP Characteristic Information is routed between input (termination) connection points ((T)CPs) and output (T)CPs by means of matrix connections. (T)CPs may be allocated within a protection group.

NOTE – Neither the number of input/output signals to the connection function, nor the connectivity is specified in this Recommendation. That is a property of individual network elements.



**Figure 9-2/G.8121/Y.1381 – MT\_C process diagram**  
**[Need to add CI\_APS, LStack, remove TSF]**

– *Routing process:*

This process passes all the traffic units received from a specific input to the corresponding output according to the matrix connection between the specified input and output, and it shall be able to remove an established matrix connection as defined by MI\_MatrixControl.

Each (matrix) connection in the MT\_C function shall be characterized by the:

Type of connection (MI_ConnectionType):	unprotected, protected
Traffic direction (MI_Return_CP_ID):	Unidirectional if NULL, otherwise it identifies the CP of the return connection (Note)
Input and output connection points (MI_ConnectionPortIDs):	set of connection point identifiers
NOTE – Bidirectional LSPs are supported by associating two unidirectional LSPs in the data plane, as per [ITU-T G.8110.1].	

– *Protection Switching process:*

Protection switching process for SNC/S is defined in clause 9.1.1.1. *For further study.*

• **Performance Monitoring:**

None.

• **Defects:**

None.

• **Consequent actions:**

If an output of this function is not connected to one of its inputs, the connection function shall send no traffic units and SSF = false to the output.

• **Defect correlations:**

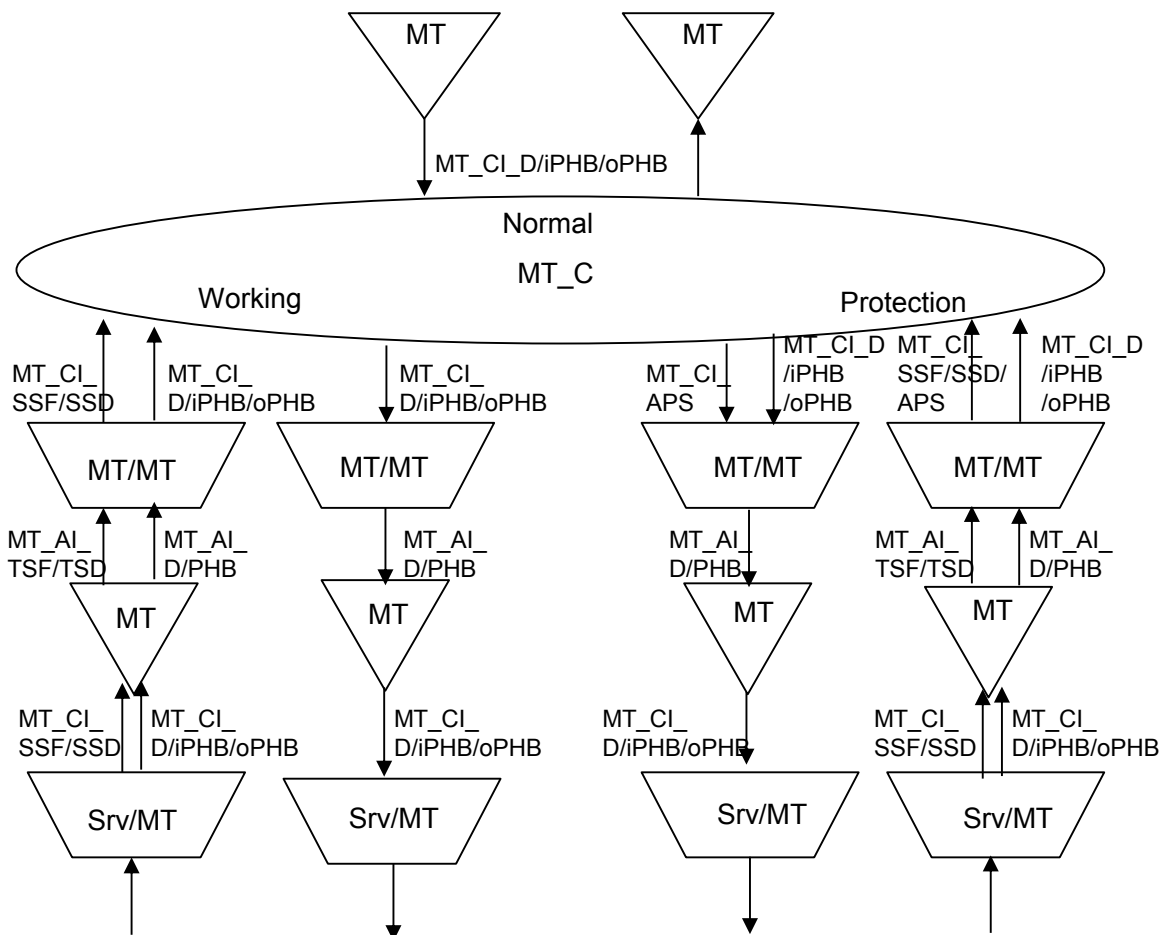
None.

**9.1.1.1 Protection process for SNC/S**

[Note: the original text is from former 9.1.2.1]

SNC protection with sublayer monitoring based on TCM is supported. For the term TCM, [RFC 6371] uses the term called Sub-Path Maintenance Elements (SPMEs).

Figure 9-2a shows the involved atomic functions in SNC/S. The MT\_TT\_Sk provides the TSF/TSD protection switching criterion via the MT/MT\_A\_Sk function (SSF/SSD) to the MT\_C function.

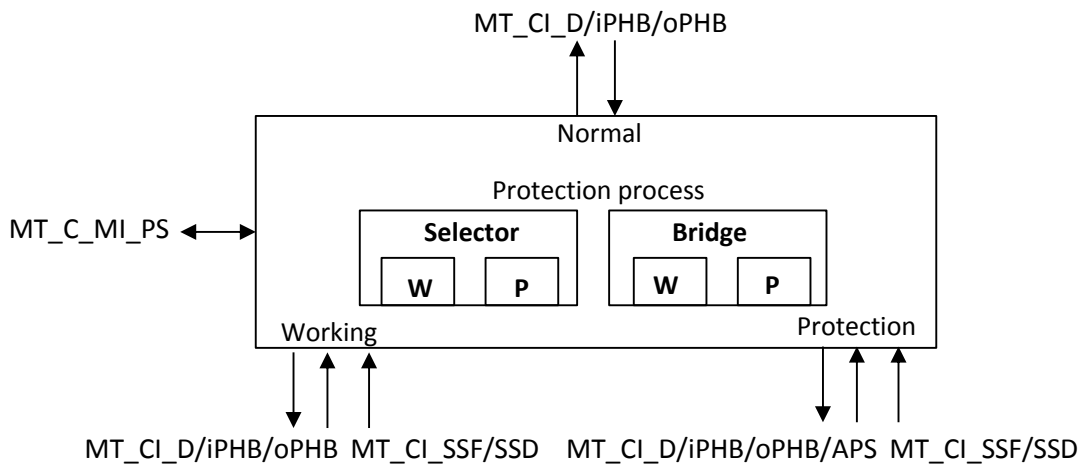


**Figure 9-2a – Involved atomic functions in SNC/S**

The protection functions at both ends operate the same way, by monitoring the working and protection subnetwork connections for defects, evaluating the system status taking into consideration the priorities of defect conditions and of external switch requests, and switching the

appropriate subnetwork connection point (i.e., working or protection) to the protected (sub)network connection point.

The signal flows associated with the MT\_protection process are described with reference to Figure 9-2b. The protection process receives control parameters and external switch requests at the MP reference point. The report of status information at the MP reference point is for further study.



**Figure 9-2b – Protection process**

#### *Source direction*

For a 1+1 architecture, the CI coming from the normal (protected) MT\_CP is bridged permanently to both the working and protection MT\_CP.

For a 1:1 architecture, the CI coming from the normal (protected) MT\_CP is switched to either the working or the protection or both MT\_CPs. ~~either the working or the protection MT\_CP~~. A switch-over from working to protection MT\_CP or vice versa is initiated by the switch initiation criteria defined below.

#### *Sink direction*

For a 1+1 or 1:1 architecture, the CI coming from either the working or protection MT\_CP is switched to the normal (protected) MT\_CP. A switch-over from working to protection MT\_CP or vice versa is initiated by the switch initiation criteria defined below.

#### *Switch initiation criteria*

Automatic protection switching is based on the defect conditions of the working and protection (sub)network connections, for SNC/S protection server signal fail (SSF) and server signal degrade (SSD).

In order to allow interworking between nested protection schemes, a hold-off timer is provided. The hold-off timer delays switch initiation, in case of signal fail, in order to allow a nested protection to react and clear the fault condition. The hold-off timer is started by the activation of signal fail and runs for the hold-off time. Protection switching is only initiated if signal fail is still present at the end of the hold-off time. The hold-off time shall be provisionable between 0 and 10 s in steps of 100 ms; this is defined in clause 8.11 of [ITU-T G.8131].

Protection switching can also be initiated by external switch commands received via the MP or a request from the far end via the received MT\_CI\_APS. Depending on the mode of operation, internal states (e.g. wait-to-restore) may also affect a switch-over.



See the switching algorithm described in [ITU-T G.8131].

### *Switching time*

Refer to [ITU-T G.8131].

### *Switch restoration*

In the revertive mode of operation, the protected signal shall be switched back from the protection (sub)network connection to the working (sub)network connection when the working (sub)network connection has recovered from the fault.

To prevent frequent operation of the protection switch due to an intermittent fault, a failed working (sub)network connection must become fault-free for a certain period of time before it is used again. This period, called the wait-to-restore (WTR) period, should be of the order of 5-12 minutes and should be capable of being set. The WTR is defined in clause 8.12 of [ITU-T G.8131].

In the non-revertive mode of operation no switch back to the working (sub)network connection is performed when it has recovered from the fault.

### *Configuration*

The following configuration parameters are defined in [ITU-T G.8131]:

MT\_C\_MI\_PS\_WorkingPortId configures the working port.

MT\_C\_MI\_PS\_ProtectionPortId configures the protection port.

MT\_C\_MI\_PS\_ProfType configures the protection type.

MT\_C\_MI\_PS\_OperType configures to be in revertive mode.

MT\_C\_MI\_PS\_HoTime configures the hold-off timer.

MT\_C\_MI\_PS\_WTR configures the wait-to-restore timer.

MT\_C\_MI\_PS\_ExtCMD configures the protection group command.

MT\_C\_MI\_PS\_SD\_Protection configures the ability of an SNC protection switching process to trigger protection switching upon SD.

### *Defects*

The function detects dFOP-PMb, dFOP-PMc, dFOP-CM, dFOP-NR and dFOP-TO defects in case the APS protocol is used.

*Consequent actions*                      None.

*Defect correlations*                      cFOP-PMb  $\Leftarrow\Leftarrow$  dFOP-PMb and (not CI\_SSF)

cFOP-PMc  $\Leftarrow\Leftarrow$  dFOP-PMc and (not CI\_SSF)

cFOP-CM  $\Leftarrow\Leftarrow$  dFOP-CM ~~and (not CI\_SSF)~~

cFOP-NR  $\Leftarrow\Leftarrow$  dFOP-NR and (not CI\_SSF)

cFOP-TO  $\Leftarrow$  dFOP-TO and (not dFOP-CM) and (not CI\_SSF)

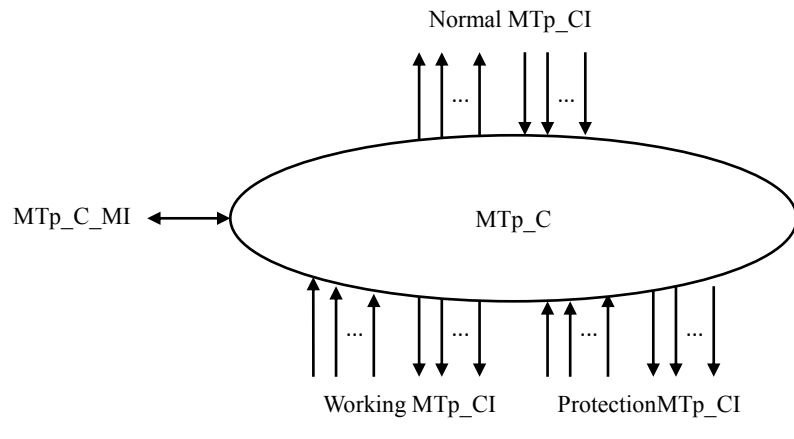
NOTE – In case of cFOP-PMb/PMc/NR/TO, CI\_SSF of the protection transport entity is used.

[For CI\_SSF, it is required to clarify whether the SSF is on the working or the protection entity. Contributions are invited. This applies to 9.1.2.1]

### 9.1.21 Connection Functions for Trail Protection (MTp\_C)

MTp\_C is the specific function that is used to support for trail protection as supported defined in [ITU-T G.8131] and assigns MPLS packets at its input ports to MPLS-TP packets at its output ports.

The MTp\_C connection process is a unidirectional function as illustrated in Figure 9-1a and the interface is described in Table 9-1a.



**Figure 9-24bba/G.8121/Y.1381 – MTp\_C symbol**

Incoming MPLS-TP packets at the normal MTp\_CP are bridged/selected to/from the working and/or protection MTp\_C by the protection switching process for trail protection assigned to available outgoing MPLS-TP capacity at the MTp\_CP. In addition, the MTp\_C function supports the trail protection schemes as defined in [ITU-T G.8131]. The Protection functionality is described in clause 9.1.2.1.

**Table 9-1a/G.8121/Y.1381 – MTp C input and output signals**

<u>Input(s)</u>	<u>Output(s)</u>
<p><b><u>Per Normal MTp CP:</u></b>  <u>MTp_CI_D</u>  <u>MTp_CI_PHB</u></p> <p><b><u>Per Working MTp CP:</u></b>  <u>MTp_CI_D</u>  <u>MTp_CI_PHB</u>  <u>MTp_CI_SSF</u>  <u>MTp_CI_SSD</u>  <u>MTp_CI_AIS</u>  <u>MTp_CI_LStack</u></p> <p><b><u>Per Protection MTp CP, n × for the function:</u></b>  <u>MTp_CI_D</u>  <u>MTp_CI_PHB</u>  <u>MTp_CI_APS</u>  <u>MTp_CI_SSF</u>  <u>MTp_CI_SSD</u></p> <p><u>MTp_CI_LStack</u></p> <p><b><u>Per input and output connection point:</u></b>  <i>for further study</i></p> <p><b><u>Per Protection group:</u></b>  <u>MTp_C_MI_PS_WorkingPortId</u>  <u>MTp_C_MI_PS_ProtectionPortId</u>  <u>MTp_C_MI_PS_ProtType</u>  <u>MTp_C_MI_PS_OperType</u>  <u>MTp_C_MI_PS_HoTime</u>  <u>MTp_C_MI_PS_WTR</u>  <u>MTp_C_MI_PS_ExtCMD</u>  <u>MTp_C_MI_PS_SD_Protection</u></p>	<p><b><u>Per Normal MTp CP:</u></b>  <u>MTp_CI_D</u>  <u>MTp_CI_PHB</u>  <u>MTp_CI_SSF</u>  <u>MTp_CI_AIS</u>  <u>MTp_CI_LStack</u></p> <p><b><u>Per Working MTp CP:</u></b>  <u>MTp_CI_D</u>  <u>MTp_CI_PHB</u></p> <p><b><u>Per Protection MTp CP, m × per function:</u></b>  <u>MTp_CI_D</u>  <u>MTp_CI_PHB</u>  <u>MTp_CI_APS</u>  <u>MTp_CI_SSF</u>  <u>MTp_CI_LStack</u></p> <p><b><u>Per Protection group:</u></b>  <u>MTp_C_MI_cFOP-PMb</u>  <u>MTp_C_MI_cFOP-PMc</u>  <u>MTp_C_MI_cFOP-CM</u>  <u>MTp_C_MI_cFOP-NR</u>  <u>MTp_C_MI_cFOP-TO</u></p>

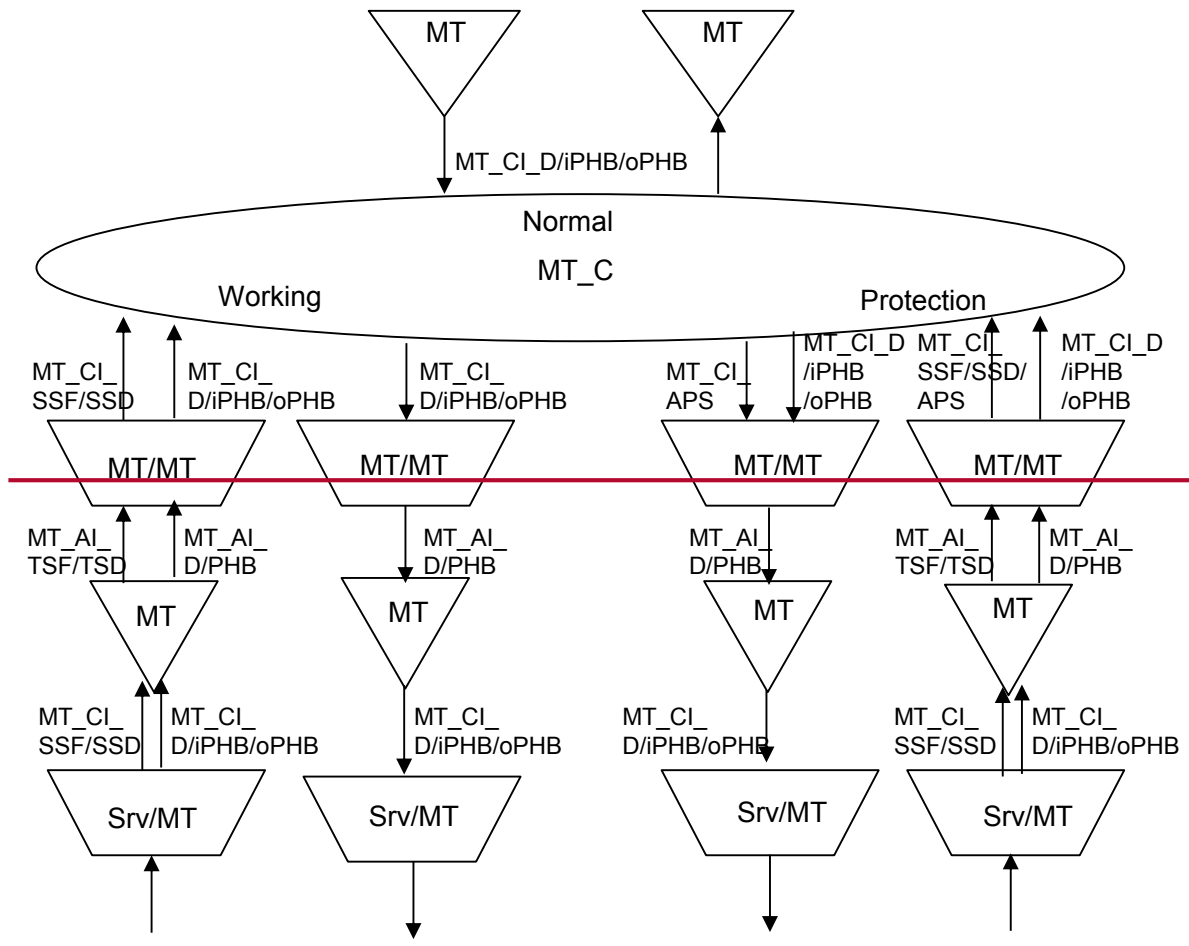
**9.1.21 Protection process**

[ITU-T G.8131] supports SNC/S protection and Trail protection, and Other types of protection is for further study.

**9.1.2.1 Protection process for SNC/S**

SNC protection with sublayer monitoring based on TCM is supported. For the term TCM, [RFC 6371] uses the term called Sub-Path Maintenance Elements (SPMEs).

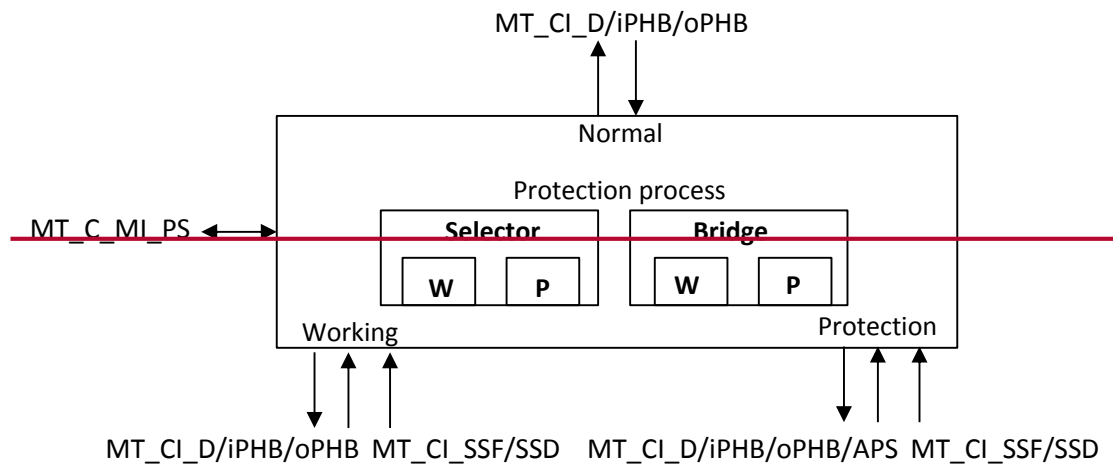
Figure 9-2a shows the involved atomic functions in SNC/S. The MT\_TT\_Sk provides the TSF/TSD protection switching criterion via the MT/MT\_A\_Sk function (SSF/SSD) to the MT\_C function.



**Figure 9-2a — Involved atomic functions in SNC/S**

The protection functions at both ends operate the same way, by monitoring the working and protection subnetwork connections for defects, evaluating the system status taking into consideration the priorities of defect conditions and of external switch requests, and switching the appropriate subnetwork connection flow point (i.e., working or protection) to the protected (sub)network connection flow point.

The signal flows associated with the MT protection process are described with reference to Figure 9-2b. The protection process receives control parameters and external switch requests at the MP reference point. The report of status information at the MP reference point is for further study.



**Figure 9-2b—Protection process**

*Source direction*

For a 1+1 architecture, the CI coming from the normal (protected) MT\_CP is bridged permanently to both the working and protection MT\_CP.

For a 1:1 architecture, the CI coming from the normal (protected) MT\_CP is switched to either the working or the protection MT\_CP **either the working protection MT\_CPs or both the working and the protection MT\_CPs**. A switch-over from working to protection MT\_CP or vice versa is initiated by the switch initiation criteria defined below.

*Sink direction*

For a 1+1 or 1:1 architecture, the CI coming from either the working or protection MT\_CP is switched to the normal (protected) MT\_CP. A switch-over from working to protection MT\_CP or vice versa is initiated by the switch initiation criteria defined below.

*Switch initiation criteria*

Automatic protection switching is based on the defect conditions of the working and protection (sub)network connections, for SNC/S protection server signal fail (SSF) and server signal degrade (SSD).

In order to allow interworking between nested protection schemes, a hold-off timer is provided. The hold-off timer delays switch initiation, in case of signal fail, in order to allow a nested protection to react and clear the fault condition. The hold-off timer is started by the activation of signal fail and runs for the hold-off time. Protection switching is only initiated if signal fail is still present at the end of the hold-off time. The hold-off time shall be provisionable between 0 and 10 s in steps of 100 ms; this is defined in clause 8.11 of [ITU-T G.8131].

Protection switching can also be initiated by external switch commands received via the MP or a request from the far end via the received MT\_CI\_APS. Depending on the mode of operation, internal states (e.g. wait-to-restore) may also affect a switch-over.

See the switching algorithm described in [ITU-T G.8131].

*Switching time*

Refer to [ITU-T G.8131].

### *Switch restoration*

In the revertive mode of operation, the protected signal shall be switched back from the protection (sub)network connection to the working (sub)network connection when the working (sub)network connection has recovered from the fault.

To prevent frequent operation of the protection switch due to an intermittent fault, a failed working (sub)network connection must become fault-free for a certain period of time before it is used again. This period, called the wait to restore (WTR) period, should be of the order of 5–12 minutes and should be capable of being set. The WTR is defined in clause 8.12 of [ITU-T G.8131].

In the non-revertive mode of operation no switch back to the working (sub)network connection is performed when it has recovered from the fault.

### *Configuration*

The following configuration parameters are defined in [ITU-T G.8131]:

- ~~MT\_C\_MI\_PS\_WorkingPortId~~ configures the working port.
- ~~MT\_C\_MI\_PS\_ProtectionPortId~~ configures the protection port.
- ~~MT\_C\_MI\_PS\_ProtType~~ configures the protection type.
- ~~MT\_C\_MI\_PS\_OperType~~ configures to be in revertive mode.
- ~~MT\_C\_MI\_PS\_HoTime~~ configures the hold-off timer.
- ~~MT\_C\_MI\_PS\_WTR~~ configures the wait to restore timer.
- ~~MT\_C\_MI\_PS\_ExtCMD~~ configures the protection group command.
- ~~MT\_C\_MI\_PS\_BridgeType~~ configures the type of bridge used for 1:1 SNC protection switching.
- ~~MT\_C\_MI\_PS\_SD\_Protection~~ configures the ability of an SNC protection switching process to trigger protection switching upon SD.

[Note....; G.8131 uses a 2-bit PT field to indicate both protection type and bridge type. However, current MIs above defines ~~ProtType~~ and ~~BridgeType~~ separately. Contributions are invited to provide the text that describes the mapping between PT field and two MIs]

### *Defects*

The function detects dFOP-PMb, dFOP-PMc, dFOP-CM, dFOP-NR and dFOP-TO defects in case the APS protocol is used.

*Consequent actions* — ~~None.~~

*Defect correlations* —  ~~$cFOP-PMb \leftarrow dFOP-PMb \text{ and } (not\ CI\_SSF)$~~

—  ~~$cFOP-PMc \leftarrow dFOP-PMc \text{ and } (not\ CI\_SSF)$~~

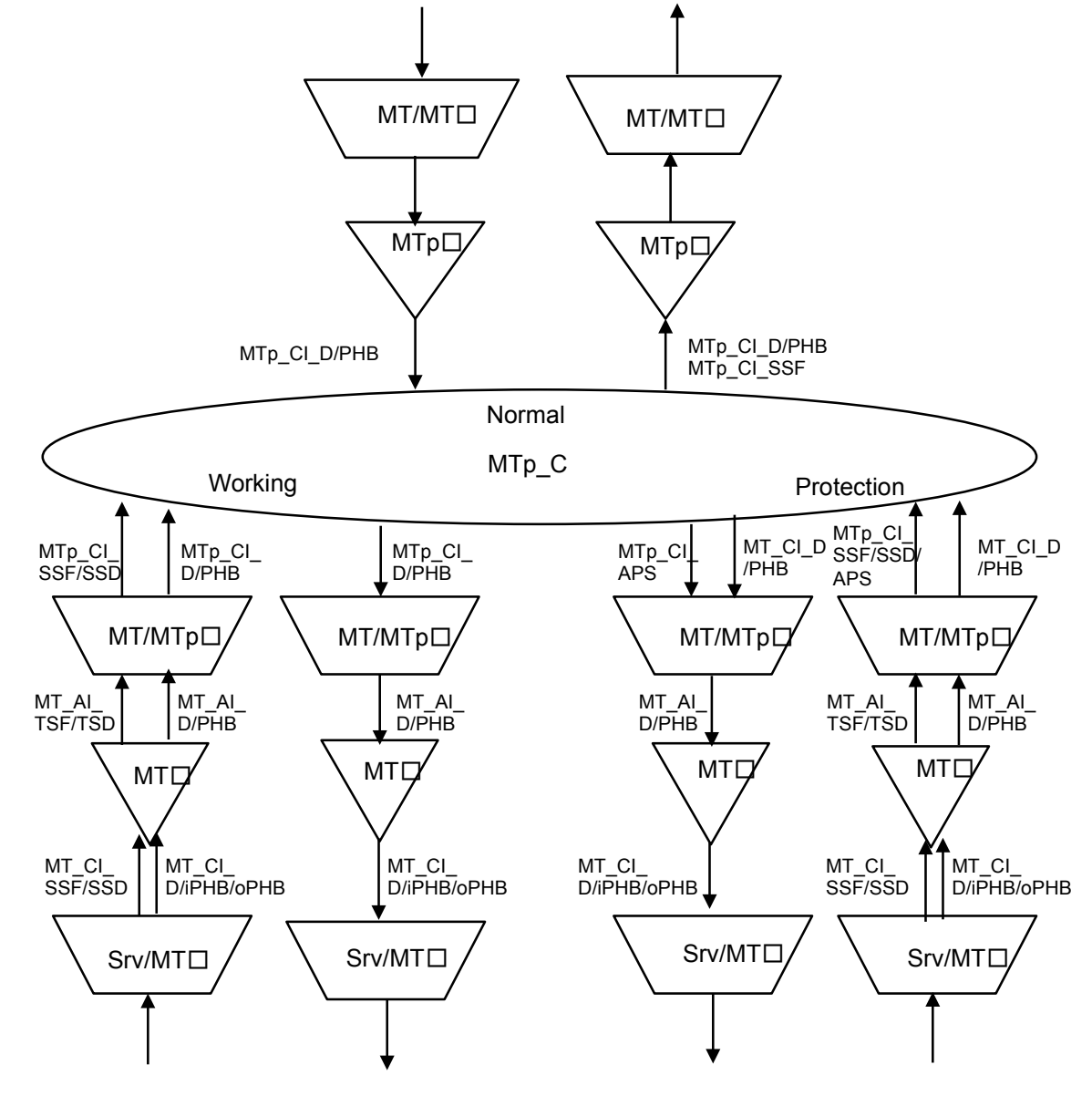
—  ~~$cFOP-CM \leftarrow dFOP-CM \text{ and } (not\ CI\_SSF)$~~

—  ~~$cFOP-NR \leftarrow dFOP-NR \text{ and } (not\ CI\_SSF)$~~

—  ~~$cFOP-TO \leftarrow dFOP-TO \text{ and } (not\ dFOP-CM) \text{ and } (not\ CI\_SSF)$~~

**9.1.2.12 Protection process for Trail protection**

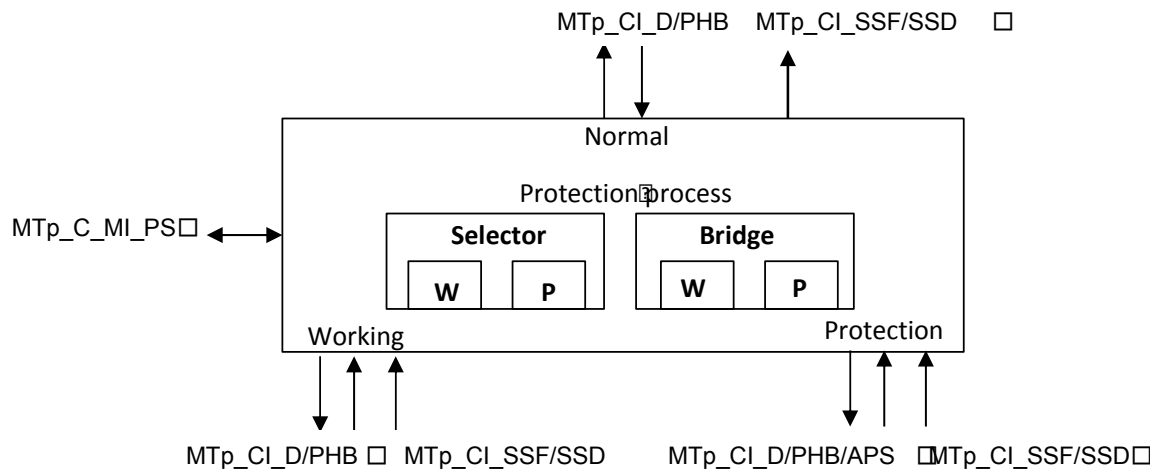
Figure 9-2c shows the involved atomic functions in Trail Protection. The MT\_TT\_Sk provides the TSF/TSD protection switching criterion via the MT/MTp\_A\_Sk function (SSF/SSD) to the MTp\_C function.



**Figure 9-2c – Involved atomic functions in Trail Protection**

The protection functions at both ends operate the same way, by monitoring the working and protection trail for defects, evaluating the system status taking into consideration the priorities of defect conditions and of external switch requests, and switching the appropriate subnetwork connection point (i.e., working or protection) to the protected (sub)network connection point.

The signal flows associated with the MTp\_protection process are described with reference to Figure 9-2d. The protection process receives control parameters and external switch requests at the MP reference point. The report of status information at the MP reference point is for further study.



**Figure 9-2d – Protection process for trail protection**

*Source direction*

For a 1+1 architecture, the CI coming from the normal (protected) MTp\_CP is bridged permanently to both the working and protection MTp\_CP.

For a 1:1 architecture, the CI coming from the normal (protected) MTp\_CP is switched to either the working or the protection or both MT\_CPs. ~~either the working or the protection MTp\_CP.~~ A switch-over from working to protection MTp\_CP or vice versa is initiated by the switch initiation criteria defined below.

*Sink direction*

For a 1+1 or 1:1 architecture, the CI coming from either the working or protection MTp\_CP is switched to the normal (protected) MTp\_CP. A switch-over from working to protection MTp\_CP or vice versa is initiated by the switch initiation criteria defined below.

*Switch initiation criteria*

Automatic protection switching is based on the defect conditions of the working and protection trails, server signal fail (SSF) and server signal degrade (SSD).

In order to allow interworking between nested protection schemes, a hold-off timer is provided. The hold-off timer delays switch initiation, in case of signal fail, in order to allow a nested protection to react and clear the fault condition. The hold-off timer is started by the activation of signal fail and runs for the hold-off time. Protection switching is only initiated if signal fail is still present at the end of the hold-off time. The hold-off time shall be provisionable between 0 and 10 s in steps of 100 ms; this is defined in clause 8.11 of [ITU-T G.8131].

Protection switching can also be initiated by external switch commands received via the MP or a request from the far end via the received MTp\_CI\_APS. Depending on the mode of operation, internal states (e.g. wait-to-restore) may also affect a switch-over.

See the switching algorithm described in [ITU-T G.8131].

*Switching time*

Refer to [ITU-T G.8131].



### Switch restoration

In the revertive mode of operation, the protected signal shall be switched back from the protection trail to the working trail when the working trail has recovered from the fault.

To prevent frequent operation of the protection switch due to an intermittent fault, a failed working trail must become fault-free for a certain period of time before it is used again. This period, called the wait-to-restore (WTR) period, should be of the order of 5-12 minutes and should be capable of being set. The WTR is defined in clause 8.12 of [ITU-T G.8131].

In the non-revertive mode of operation no switch back to the working trail is performed when it has recovered from the fault.

### Configuration

The following configuration parameters are defined in [ITU-T G.8131]:

MTp\_C\_MI\_PS\_WorkingPortId configures the working port.

MTp\_C\_MI\_PS\_ProtectionPortId configures the protection port.

MTp\_C\_MI\_PS\_ProtType configures the protection type.

MTp\_C\_MI\_PS\_OperType configures to be in revertive mode.

MTp\_C\_MI\_PS\_HoTime configures the hold-off timer.

MTp\_C\_MI\_PS\_WTR configures the wait-to-restore timer.

MTp\_C\_MI\_PS\_ExtCMD configures the protection group command.

MTp\_C\_MI\_PS\_SD\_Protection configures the ability of a trail protection switching process to trigger protection switching upon SD.

### Defects

The function detects dFOP-PMb, dFOP-PMc, dFOP-CM, dFOP-NR and dFOP-TO defects in case the APS protocol is used.

Consequent actions None.

Defect correlations cFOP-PMb  $\leftarrow\leftarrow$  dFOP-PMb and (not CI\_SSF)

cFOP-PMc  $\leftarrow\leftarrow$  dFOP-PMc and (not CI\_SSF)

cFOP-CM  $\leftarrow\leftarrow$  dFOP-CM ~~and (not CI\_SSF)~~

cFOP-NR  $\leftarrow\leftarrow$  dFOP-NR and (not CI\_SSF)

cFOP-TO  $\leftarrow$  dFOP-TO and (not dFOP-CM) and (not CI\_SSF)

NOTE – In case of cFOP-PMb/PMc/NR/TO, CI\_SSF of the protection transport entity is used.

[Note: For CI\_SSF, see comments in 9.1.1.1]

## **9.2 Termination functions**

### **-9.2.1 MPLS-TP Trail Termination function (MT\_TT)**

The bidirectional MPLS-TP Trail Termination (MT\_TT) function terminates the MPLS-TP OAM to determine the status of the MPLS-TP (sub)layer trail. The MT\_TT function is performed by a co-located pair of the MPLS-TP trail termination source (MT\_TT\_So) and sink (MT\_TT\_Sk) functions as shown in Figure 9-3.

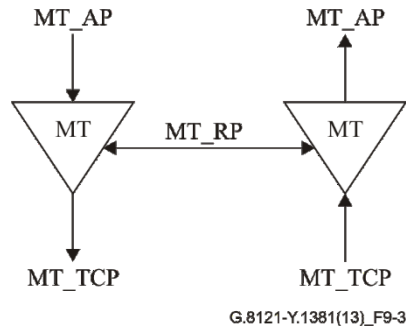


Figure 9-3/G.8121/Y.1381 – MT\_TT

9.2.1.1 MPLS-TP Trail Termination Source function (MT\_TT\_So)

The MT\_TT\_So function determines and inserts the TTL value in the shim header TTL field and adds MPLS-TP OAM for pro-active monitoring to the MT\_AI signal at its MT\_AP.

• **Symbol:**

The MT\_TT\_So function symbol is shown in Figure 9-4.

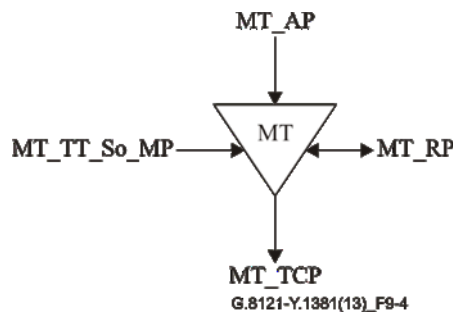


Figure 9-4/G.8121/Y.1381 –MT\_TT\_So function

• **Interfaces:**

Table 9-2/G.8121/Y.1381 – MT\_TT\_So inputs and outputs

Input(s)	Output(s)
<b>MT_AP:</b> MT_AI_D MT_AI_PHB  <b>MT_RP:</b> MT_RI_CC_RDI MT_RI_CC_BlK MT_RI_OAM_Info(D,CoS,DP)  <b>MT_TT_So_MP:</b> MT_TT_So_MI_GAL_Enable	<b>MT_TCP:</b> MT_CI_D MT_CI_oPHB MT_CI_iPHB  <b>MT_RP:</b>

MT\_TT\_So\_MI\_TTLVALUE  
MT\_TT\_So\_MI\_MEG\_ID  
MT\_TT\_So\_MI\_MEP\_ID

MT\_TT\_So\_MI\_CC\_OAM\_Tool  
MT\_TT\_So\_MI\_RDI\_OAM\_Tool  
MT\_TT\_So\_MI\_CC\_Enable (Note)  
MT\_TT\_So\_MI\_CVp\_Enable (Note)  
MT\_TT\_So\_MI\_CC\_CoS  
MT\_TT\_So\_MI\_CC\_Period

MT\_TT\_So\_MI\_1LMp\_Enable

MT\_TT\_So\_MI\_LMp\_OAM\_Tool[1...M<sub>LMp</sub>]  
MT\_TT\_So\_MI\_LMp\_Enable[1...M<sub>LMp</sub>]  
MT\_TT\_So\_MI\_LMp\_Period[1...M<sub>LMp</sub>]  
MT\_TT\_So\_MI\_LMp\_CoS[1...M<sub>LMp</sub>]

MT\_TT\_So\_MI\_DMp\_OAM\_Tool[1...M<sub>DMp</sub>]  
MT\_TT\_So\_MI\_DMp\_Enable[1...M<sub>DMp</sub>]  
MT\_TT\_So\_MI\_DMp\_Period[1...M<sub>DMp</sub>]  
MT\_TT\_So\_MI\_DMp\_Test\_ID[1...M<sub>DMp</sub>]  
MT\_TT\_So\_MI\_DMp\_CoS[1...M<sub>DMp</sub>]  
MT\_TT\_So\_MI\_DMp\_Length[1...M<sub>DMp</sub>]

MT\_TT\_So\_MI\_1DMp\_OAM\_Tool[1...M<sub>1DMp</sub>]  
MT\_TT\_So\_MI\_1DMp\_Enable[1...M<sub>1DMp</sub>]  
MT\_TT\_So\_MI\_1DMp\_Period[1...M<sub>1DMp</sub>]  
MT\_TT\_So\_MI\_1DMp\_Test\_ID[1...M<sub>1DMp</sub>]  
MT\_TT\_So\_MI\_1DMp\_Length[1...M<sub>1DMp</sub>]  
MT\_TT\_So\_MI\_1DMp\_CoS[1...M<sub>1DMp</sub>]

MT\_TT\_So\_MI\_SLp\_OAM\_Tool[1...M<sub>SLp</sub>]  
MT\_TT\_So\_MI\_SLp\_Enable[1...M<sub>SLp</sub>]  
MT\_TT\_So\_MI\_SLp\_Period[1...M<sub>SLp</sub>]  
MT\_TT\_So\_MI\_SLp\_Test\_ID[1...M<sub>SLp</sub>]  
MT\_TT\_So\_MI\_SLp\_Length[1...M<sub>SLp</sub>]  
MT\_TT\_So\_MI\_SLp\_CoS[1...M<sub>SLp</sub>]

MT\_TT\_So\_MI\_1SLp\_OAM\_Tool[1...M<sub>1SLp</sub>]  
MT\_TT\_So\_MI\_1SLp\_Enable[1...M<sub>1SLp</sub>]  
MT\_TT\_So\_MI\_1SLp\_Period[1...M<sub>1SLp</sub>]  
MT\_TT\_So\_MI\_1SLp\_Test\_ID[1...M<sub>1SLp</sub>]  
MT\_TT\_So\_MI\_1SLp\_Length[1...M<sub>1SLp</sub>]  
MT\_TT\_So\_MI\_1SLp\_CoS[1...M<sub>1SLp</sub>]

**MT\_TP:**

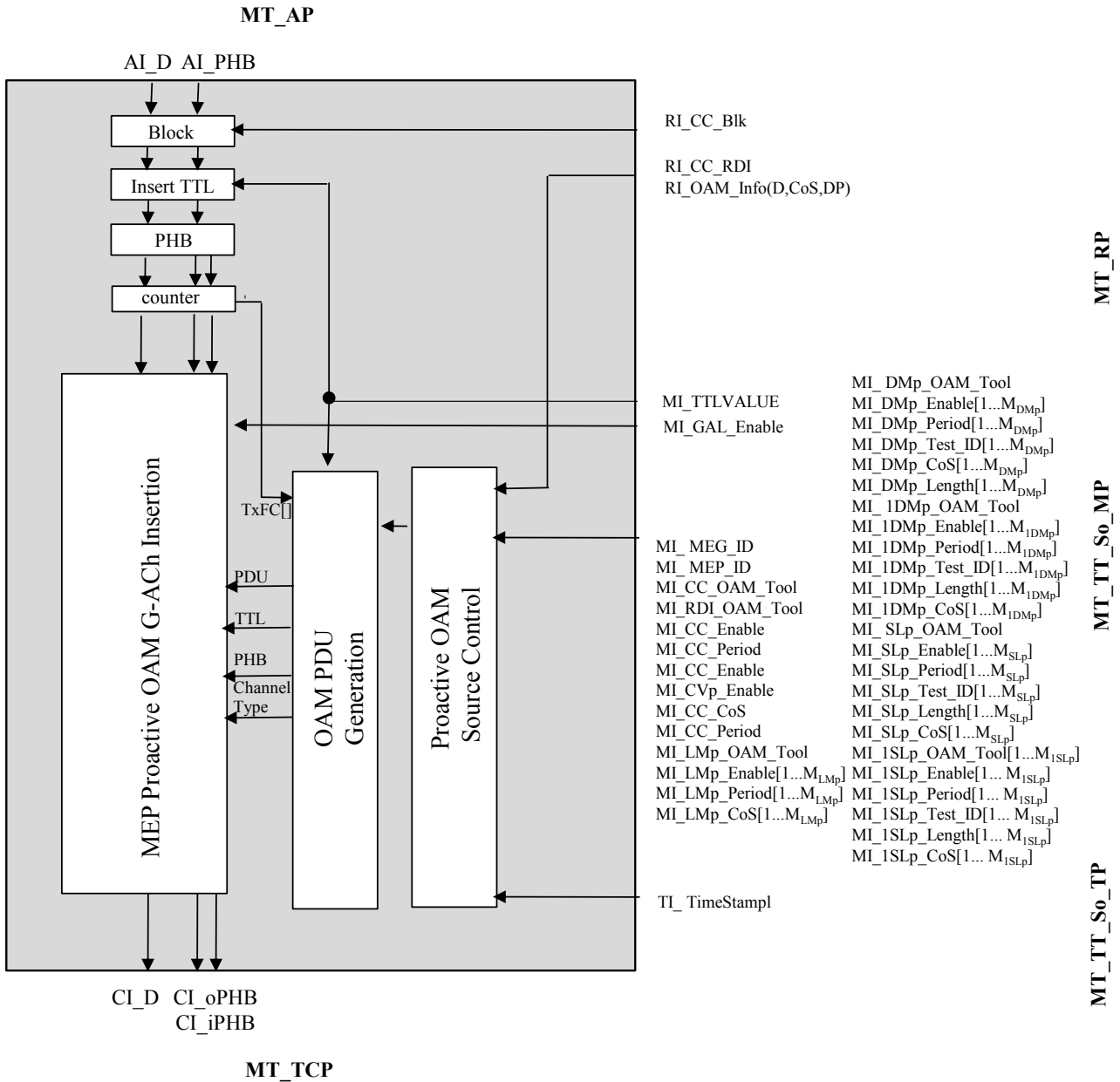
MT\_TT\_So\_TI\_TimeStamp

NOTE- MI\_CC\_Enable and MI\_CVp\_Enable are used to enable CC and CV functions respectively.  
The possible combinations are:

- no CC function and no CV function: MI\_CC\_Enable = false and MI\_CVp\_Enable = false
- CC-only function: MI\_CC\_Enable = true and MI\_CVp\_Enable = false
- CC and CV functions: MI\_CC\_Enable = true and MI\_CVp\_Enable = true

• **Processes:**

The processes associated with the MT\_TT\_So function are as depicted in Figure 9-5.



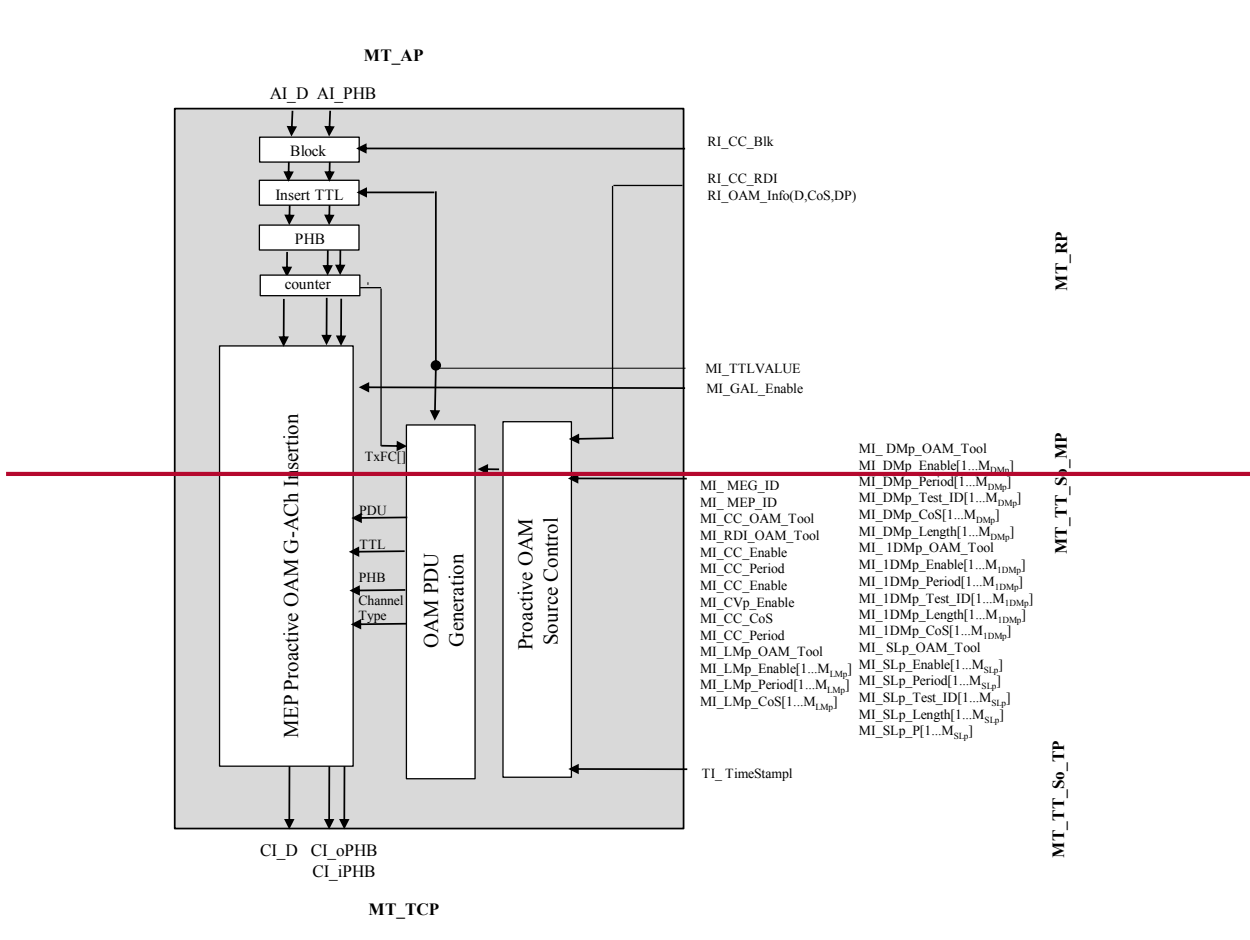


Figure 9-5/G.8121/Y.1381 –MT\_TT\_So process diagram

Notes:

1. The interface between Pro-active OAM Control and OAM PDU Generation is protocol specific.
2. Note that the parameters & values in the MT\_TT\_So\_MI\_XX\_OAM\_Tool are outside the scope of this recommendation.

**Block:** When RI\_CC\_Blk is raised, the Block process will discard all AI\_D traffic units it receives. If RI\_CC\_Blk is cleared, the received AI\_D traffic units will be passed to the output port.

**Insert TTL:** The Time To Live value is inserted in the outer shim header's TTL field within the MT\_AI traffic unit

**PHB:** The AI\_PHB signal is assigned to both the CI\_iPHB and CI\_oPHB signals at the MT\_TCP reference point.

**Counter:** [This process is used to count packets for proactive loss measurements. The location of the counter process is shown for illustration. The exact set of packets to be counted is outside of the scope in this Recommendation. For Further Study.](#)

**MEP Proactive OAM G-ACh Insertion** See 8.1.

**OAM PDU Generation:** See 8.8

**Pro-active OAM Source Control:** See 8.8

• **Defects:**

*None.*

• **Consequent actions:**

*None.*

• **Defect correlations:**

*None.*

• **Performance monitoring:**

*None.*

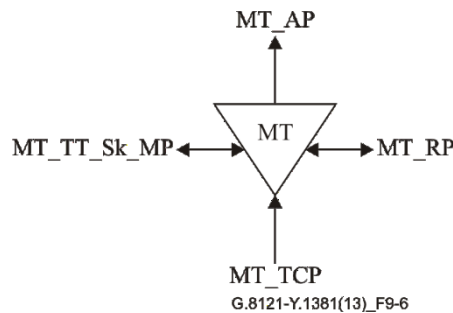
**9.2.1.2 MPLS-TP Trail Termination Sink function (MT\_TT\_Sk)**

The MT\_TT\_Sk function reports the state of the MPLS-TP Trail (Network Connection). It extracts MPLS-TP trail OAM - for pro-active monitoring - from the MPLS-TP signal at its MT\_TCP, detects defects, counts during 1-second periods errors and defects to feed Performance Monitoring when connected and forwards the defect information as backward indications to the companion MT\_TT\_So function.

Note – The MT\_TT\_Sk function extracts and processes one level of MPLS-TP OAM irrespective of the presence of more levels.

• **Symbol:**

The MT\_TT\_Sk function symbol is shown in Figure 9-6.



**Figure 9-6/G.8121/Y.1381 – MT\_TT\_Sk function**

• **Interfaces:**

**Table 9-3/G.8121/Y.1381 – MT\_TT\_Sk inputs and outputs**

Input(s)	Output(s)
<b>MT_TCP:</b> MT_CI_D MT_CI_iPHB	<b>MT_AP:</b>

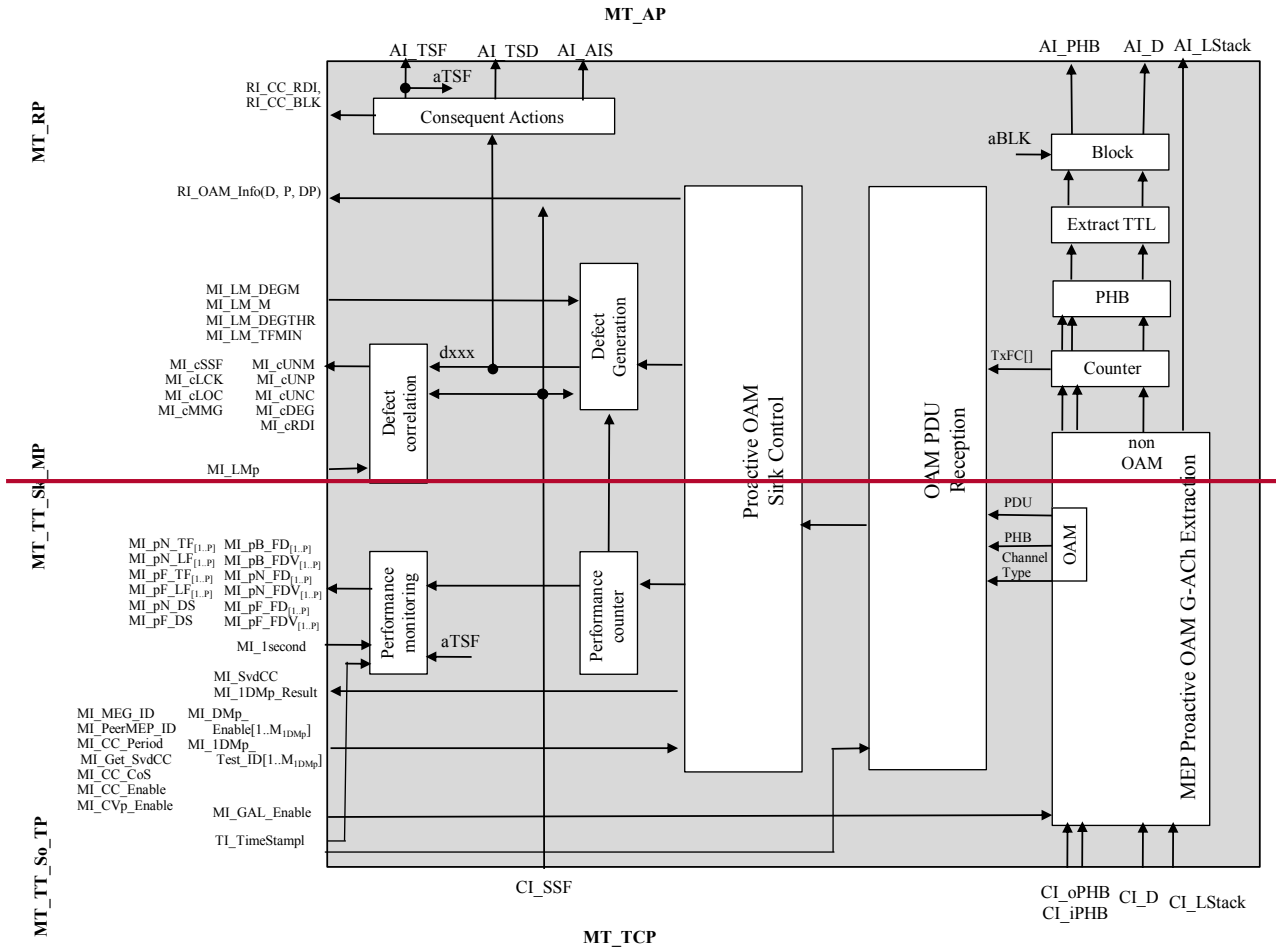
Input(s)	Output(s)
<p>MT_CI_oPHB MT_CI_SSF MT_CI_Lstack</p> <p><b>MT_RP:</b></p> <p><b>MT_TT_Sk_MP:</b> MT_TT_Sk_MI_GAL_Enable MT_TT_Sk_MI_MEG_ID MT_TT_Sk_MI_PeerMEP_ID MT_TT_Sk_MI_CC_OAM_Tool MT_TT_Sk_MI_RDI_OAM_Tool</p> <p>MT_TT_Sk_MI_CC_Enable(Note) MT_TT_Sk_MI_CVp_Enable (Note)</p> <p>MT_TT_Sk_MI_CC_Period MT_TT_Sk_MI_CC_CoS MT_TT_Sk_MI_Get_SvdCC</p> <p><a href="#">MT_TT_Sk_MI_1LMp_Enable</a></p> <p>MT_TT_Sk_MI_LMp_OAM_Tool[1... M<sub>LMp</sub>] MT_TT_Sk_MI_LMp_Enable[1... M<sub>LMp</sub>] MT_TT_Sk_MI_LMp_CoS[1... M<sub>LMp</sub>] MT_TT_Sk_MI_LM_DEGM MT_TT_Sk_MI_LM_M MT_TT_Sk_MI_LM_DEGTHR MT_TT_Sk_MI_LM_TFMIN</p> <p>MT_TT_Sk_MI_DMp_OAM_Tool[1... M<sub>DMp</sub>] MT_TT_Sk_MI_DMp_Enable[1... M<sub>DMp</sub>] MT_TT_Sk_MI_DMp_CoS[1... M<sub>DMp</sub>]</p> <p>MT_TT_Sk_MI_1DMp_OAM_Tool [1...M<sub>1DMp</sub>] MT_TT_Sk_MI_1DMp_Enable[1...M<sub>1DMp</sub>] MT_TT_Sk_MI_1DMp_Test_ID[1...M<sub>1DMp</sub>]</p> <p>MT_TT_Sk_MI_SLp_OAM_Tool[1... M<sub>SLp</sub>] MT_TT_Sk_MI_SLp_Enable[1... M<sub>SLp</sub>] MT_TT_Sk_MI_SLp_CoS[1... M<sub>SLp</sub>]</p> <p><a href="#">MT_TT_Sk_MI_1SLp_OAM_Tool</a> <a href="#">MT_TT_Sk_MI_1SLp_Enable[1...M<sub>1SLp</sub>]</a> <a href="#">MT_TT_Sk_MI_1SLp_Test_ID[1...M<sub>1SLp</sub>]</a></p> <p>MT_TT_Sk_MI_AIS_OAM_Tool</p>	<p>MT_AI_D MT_AI_PHB MT_AI_TSF MT_AI_TSD MT_AI_AIS</p> <p>MT_AI_LStack</p> <p><b>MT_RP:</b> MT_RI_CC_RDI MT_RI_CC_BlK</p> <p>MT_RI_OAM_Info(D,CoS,DP)</p> <p><b>MT_TT_Sk_MP:</b> MT_TT_Sk_MI_SvdCC MT_TT_Sk_MI_cSSF MT_TT_Sk_MI_cLCK MT_TT_Sk_MI_cLOC MT_TT_Sk_MI_cMMG MT_TT_Sk_MI_cUNM MT_TT_Sk_MI_cUNP</p> <p>MT_TT_Sk_MI_cUNC</p> <p>MT_TT_Sk_MI_cDEG MT_TT_Sk_MI_cRDI MT_TT_Sk_MI_pN_LF[1...P] MT_TT_Sk_MI_pN_TF[1...P] MT_TT_Sk_MI_pF_LF[1...P] MT_TT_Sk_MI_pF_TF[1...P] MT_TT_Sk_MI_pF_DS MT_TT_Sk_MI_pN_DS MT_TT_Sk_MI_pB_FD[1...P] MT_TT_Sk_MI_pB_FD[1...P] MT_TT_Sk_MI_pN_FD[1...P] MT_TT_Sk_MI_pN_FD[1...P] MT_TT_Sk_MI_pF_FD[1...P] MT_TT_Sk_MI_pF_FD[1...P]</p>

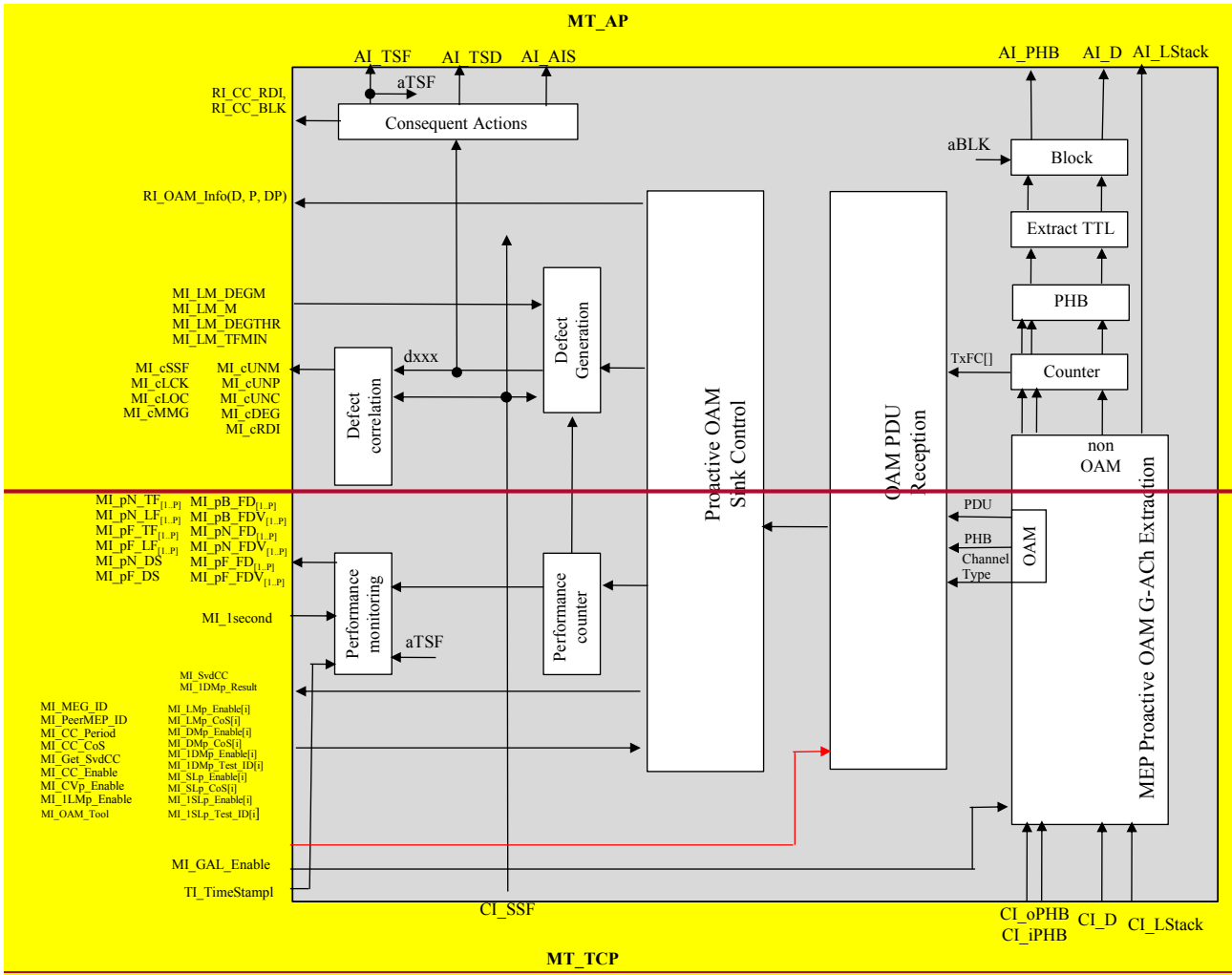
<b>Input(s)</b>	<b>Output(s)</b>
MT_TT_Sk_MI_LCK_OAM_Tool  MT_TT_Sk_MI_1second  <b>MT_TP:</b> MT_TT_Sk_TI_TimeStampI	
NOTE - See NOTE in Table 9-2	

• **Processes:**

The processes associated with the MT\_TT\_Sk function are as depicted in Figure 9-7.







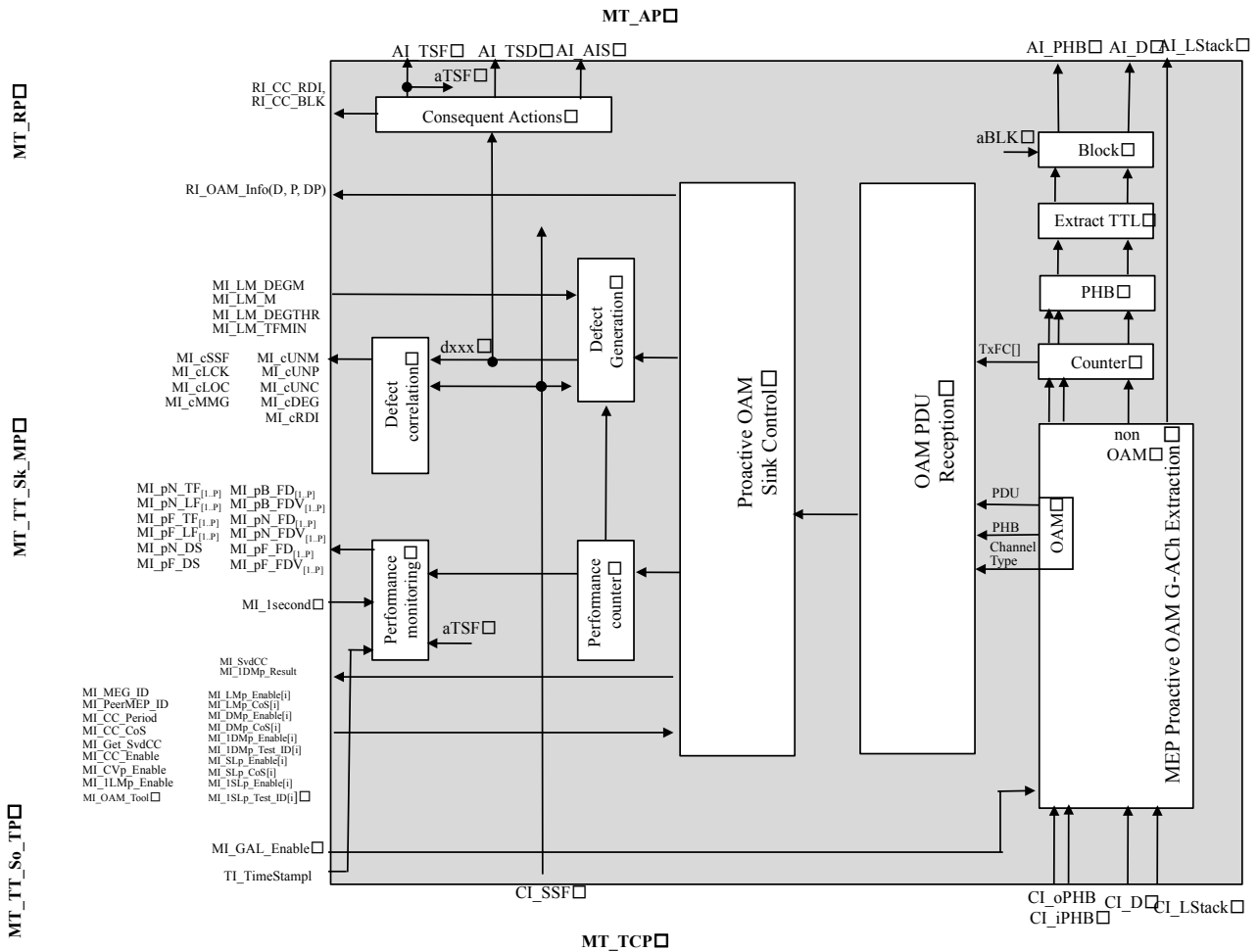


Figure 9-7/G.8121/Y.1381 – MT\_TT\_Sk process diagram

[New figure for this revision]

Note - The parameters & values in the MT\_TT\_Sk\_MI\_XX\_OAM\_Tool are outside the scope of this recommendation.

**Extract TTL:** The Time To Live value is extracted from the outer shim header's TTL field within the MT\_CI traffic unit

**Block:** When the aBlock consequent action is asserted, this process drops all traffic units arriving at its input.

**PHB:** The CI\_oPHB signal is assigned to the AI\_PHB signal at the reference point MT\_AP.

Note that the CI\_iPHB signal is not used by any of the processes in the function.

**Counter:** [This process is used to count packets for proactive loss measurements. The location of the counter process is shown for illustration only. The exact set of packets to be counted is outside of the scope in this Recommendation. For Further Study.](#)

**MEP Proactive OAM G-ACh Extraction:** See 8.1.3. The process of CI\_D is made according to the following rule:

```
if ( ((MI_GAL_Enable && MT-label(D) == GAL) ||
```

```
(!MI_GAL_Enable && 1stNibble(D) == 0b0001) &&  
  (Packet_Type(D) == Proactive_OAM && !APS_OAM) )  
  forward to G-ACh port  
} else {  
  forward to data port  
}
```

Note: MT-label(D) and 1stNibble(D) are functions which return, respectively, the Label field at the top of the stack within the MPLS payload, the first nibble of the MPLS payload as defined in Figure 6-3/G.8110.1.

These fields are used to identify G-ACh packets as described in section 4.2.1 of [RFC 5586]. Packet\_Type (D) is a protocol-specific function that determines whether the Traffic Unit contains a Proactive OAM packet.

**OAM PDU Reception:** See 8.8

**Proactive OAM Sink Control:** See 8.8

**Performance counter:** For further study

• **Defects Generation:**

This function detects and clear the defects (dLOC, dMMG, dUNM, dDEG, dUNP, dUNC, dRDI, dAIS and dLCK) as defined in clause 6.1

• **Consequent actions:**

aBLK ← (dMMG or dUNM)

aTSF ← (dLOC and MI\_CC\_Enable) or (dAIS and not(MI\_CC\_Enable)) or (dLCK and not(MI\_CC\_Enable)) or dMMG or dUNM or CI\_SSF

aTSD ← dDEG and (not aTSF)

aAIS ← aTSF

**aRDI ← aTSF**

**Defect correlations:**  
cLOC ← dLOC and (not dAIS) and (not dLCK) and (not CI\_SSF) and (MI\_CC\_Enable)

cMMG ← dMMG

cUNM ← dUNM

cDEG ← dDEG and (not dAIS) and (not dLCK) and (not CI\_SSF) and (not (dLOC or dMMG or dUNM)) and (MI\_CC\_Enable)

cUNP ← dUNP

cUNC ← dUNC

cRDI ← dRDI and (MI\_CC\_Enable)

cSSF ← CI\_SSF or dAIS

cLCK ← dLCK and (not dAIS)

• **Performance monitoring:**

For further study

**9.2.2 MPLS-TP Trail Termination function for Trail Protection (MTp TT)**

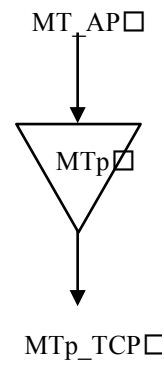
The MTp TT function is used for trail protection and it is included to satisfy the modelling rules.

The bidirectional MTp TT is performed by a co-located pair of MTp TT source (MTp TT So) and sink (MTp TT Sk) functions.

**9.2.2.1 MPLS-TP Trail Termination Source function for Trail Protection (MTp TT So)**

• **Symbol:**

The MT TT So function symbol is shown in Figure 9-7x+1.



**Figure 9-7x+1/G.8121/Y.1381 –MTp TT So function**

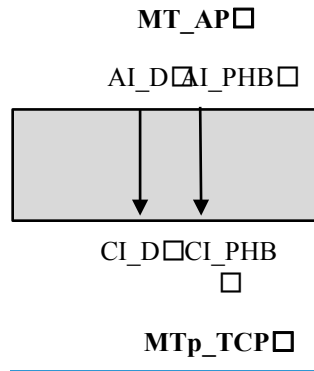
• **Interfaces:**

**Table 9-3x+1/G.8121/Y.1381 – MT TT So inputs and outputs**

<b>Input(s)</b>	<b>Output(s)</b>
<u>MT AP:</u> <u>MT AI D</u> <u>MT AI PHB</u>	<u>MTp TCP:</u> <u>MTp CI D</u> <u>MTp CI PHB</u>

• **Processes:**

The processes associated with the MTp TT So function are as depicted in Figure 9-7x+2.



**Figure 9-7x+2/G.8121/Y.1381 – MTp TT So process diagram**

**• Defects:**

*None.*

**• Consequent actions:**

*None*

**• Defect correlations:**

*None.*

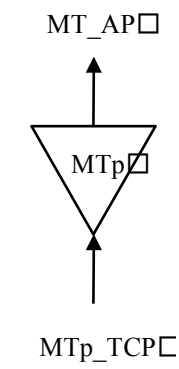
**• Performance monitoring:**

*None.*

**9.2.2.2 MPLS-TP Trail Termination Sink function for Trail Protection (MTp TT Sk)**

**• Symbol:**

The MTp\_TT\_Sk function symbol is shown in Figure 9-7x+3.



**Figure 9-7x+3/G.8121/Y.1381 – MTp TT Sk function**

• Interfaces:

Table 9-3x+2/G.8121/Y.1381 – MT TT Sk inputs and outputs

<u>Input(s)</u>	<u>Output(s)</u>
<u>MTp TCP:</u> <u>MTp CI D</u> <u>MTp CI PHB</u> <u>MTp CI Lstack</u>  <u>MTp CI SSF</u> <u>MTp CI AIS</u>	<u>MT AP:</u> <u>MT AI D</u> <u>MT AI PHB</u> <u>MT AI LStack</u>  <u>MT AI TSF</u> <u>MTp CI AIS</u>

• Processes:

The processes associated with the MT TT Sk function are as depicted in Figure 9-7x+4.

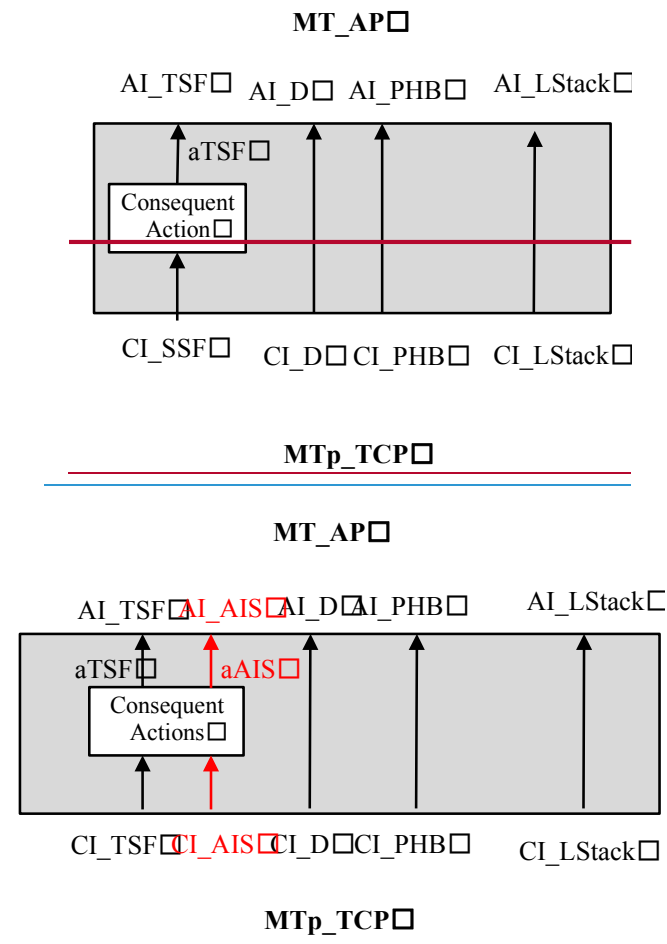


Figure 9-7x+4/G.8121/Y.1381 – MTp TT Sk process diagram  
[Add CI AIS input and AI AIS output to the Consequent Action]

• **Defects:**

*None.*

• **Consequent actions:**

The function shall perform the following consequent actions:

$aTSF \leftarrow CI\_SSF$

$aAIS \leftarrow CI\_AIS$

• **Defect correlations:**

*None.*

• **Performance monitoring:**

*None.*

### 9.3 Adaptation functions

#### 9.3.1 MPLS-TP to MPLS-TP adaptation function (MT/MT\_A)

##### 9.3.1.1 MPLS-TP to MPLS-TP adaptation source function (MT/MT\_A\_So)

• **Symbol:**

The MT/MT\_A\_So function symbol is shown in Figure 9-8. This function maps client MT\_CI traffic units into server MT\_AI traffic units.

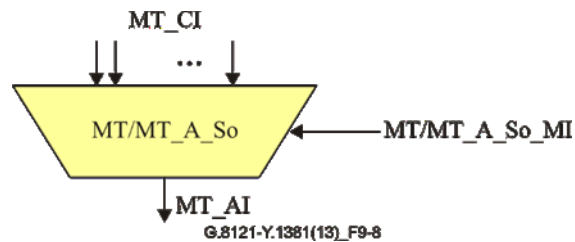


Figure 9-8/G.8121/Y.1381 – MT/MT\_A\_So function



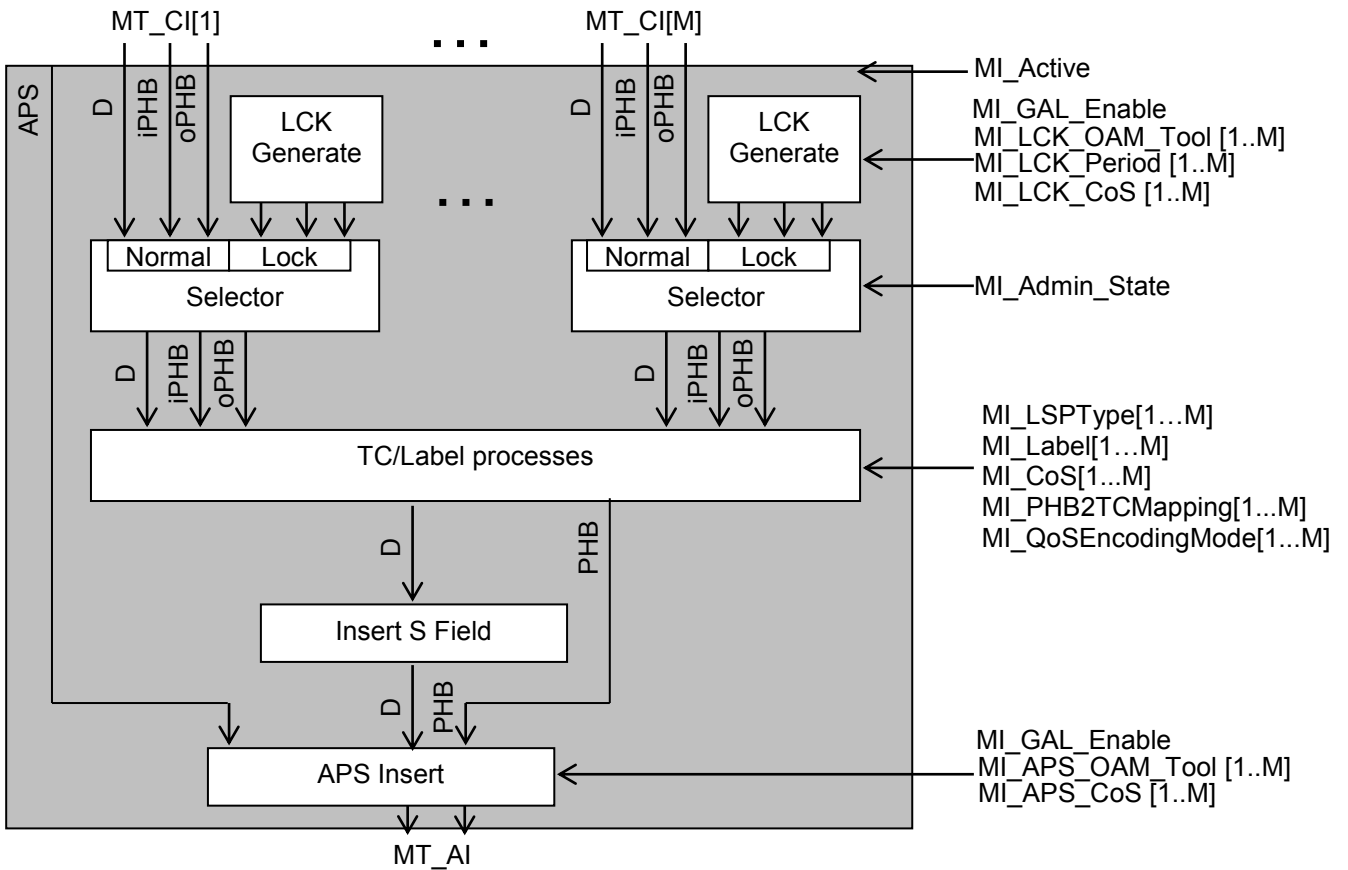
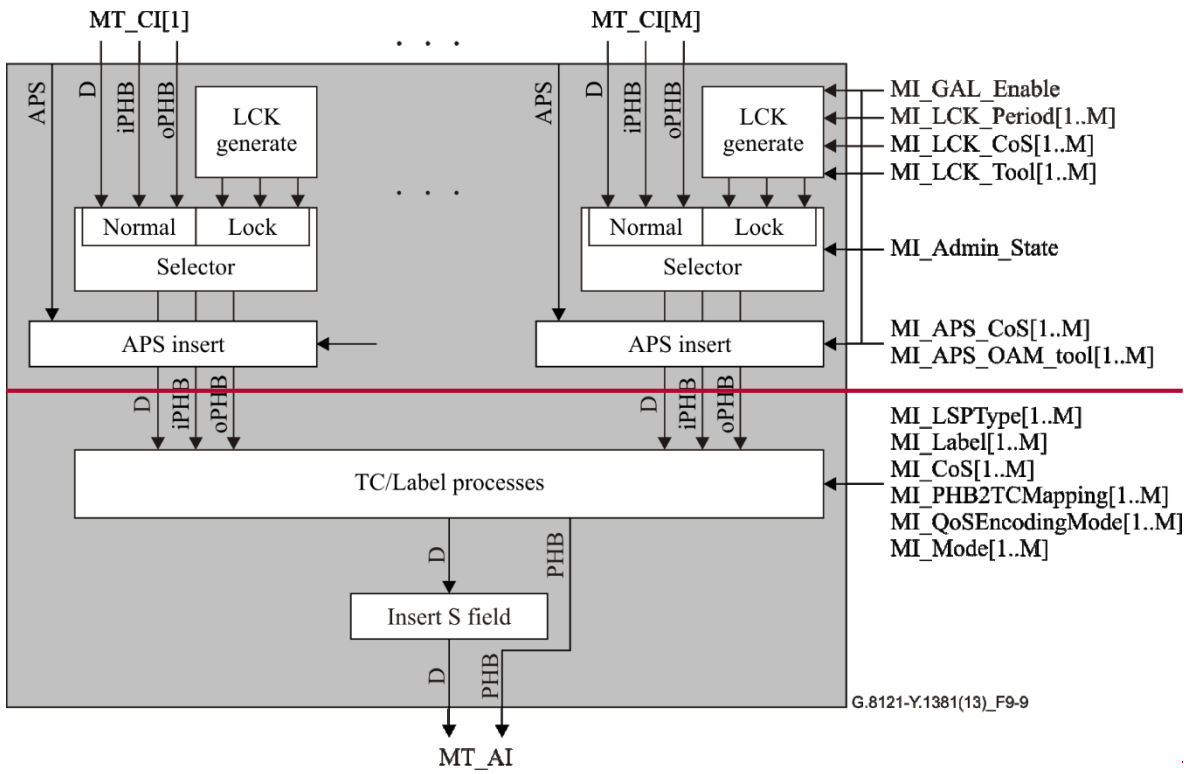
• **Interfaces:**

**Table 9-4/G.8121/Y.1381 – MT/MT\_A\_So interfaces**

Inputs	Outputs
<p><b>Each MT_CP:</b>            MT_CI_Data            MT_CI_iPHB            MT_CI_oPHB</p> <p><b>MT_CP:</b>            MT_CI_APS</p> <p><b>MT/MT_A_So_MI:</b>            MT/MT_A_So_MI_Active            MT/MT_A_So_MI_Admin_State            MT/MT_A_So_MI_Label[1...M]            MT/MT_A_So_MI_LSPTType[1...M]            MT/MT_A_So_MI_CoS[1...M]            MT/MT_A_So_MI_PHB2TCMapping[1...M]            MT/MT_A_So_MI_QoSEncodingMode[1...M]            MT/MT_A_So_MI_Mode</p> <p>MT/MT_A_So_MI_LCK_Period[1...M]            MT/MT_A_So_MI_LCK_CoS[1...M]            MT/MT_A_So_MI_LCK_OAM_Tool[1...M]            MT/MT_A_So_MI_GAL_Enable[1...M]</p> <p>MT/MT_A_So_MI_APS_CoS            MT/MT_A_So_MI_APS_OAM_Tool</p>	<p><b>MT_AP:</b>            MT_AI_Data            MT_AI_PHB</p>

• **Processes:**

The processes associated with the MT/MT\_ ~~TTA~~ TTA \_So function are as depicted in Figure 9-9.



**Figure 9-9/G.8121/Y.1381 – MT/MT\_A\_So process diagram**  
(->LCK\_OAM\_Tool[1...M], APS\_OAM\_Tool[1...M], MI\_Active)

– *LCK Generate process:*

See 8.6.3. Each CP has its LCK Generate process.

– *Selector process:*

See 8.6.1. The normal CI is blocked if Admin\_State = LOCKED.

– *TC/Label processes:*

See 8.2.1.

– *S Field Insertion:*

A 1-bit S Field set to 0 (not bottom of label stack) is inserted to indicate the client is MPLS.

– *APS Insert processes:*

See 8.7.2.1.

• **Defects:**

None.

• **Consequent actions:**

None.

• **Defect correlations:**

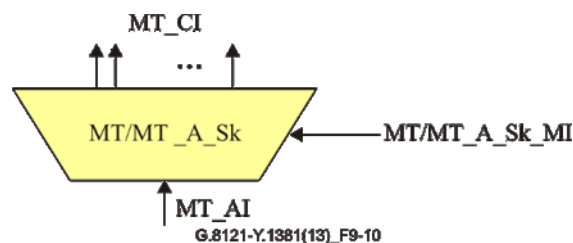
None.

• **Performance monitoring:**

None.

**9.3.1.2 MPLS-TP to MPLS-TP adaptation sink function (MT/MT\_A\_Sk)**

The MT/MT\_A\_Sk function symbol is shown in Figure 9-10. This function retrieves client MT\_CI traffic units from server MT\_AI traffic units.



**Figure 9-10/G.8121/Y.1381 – MT/MT\_A\_Sk function**

• **Interfaces:**

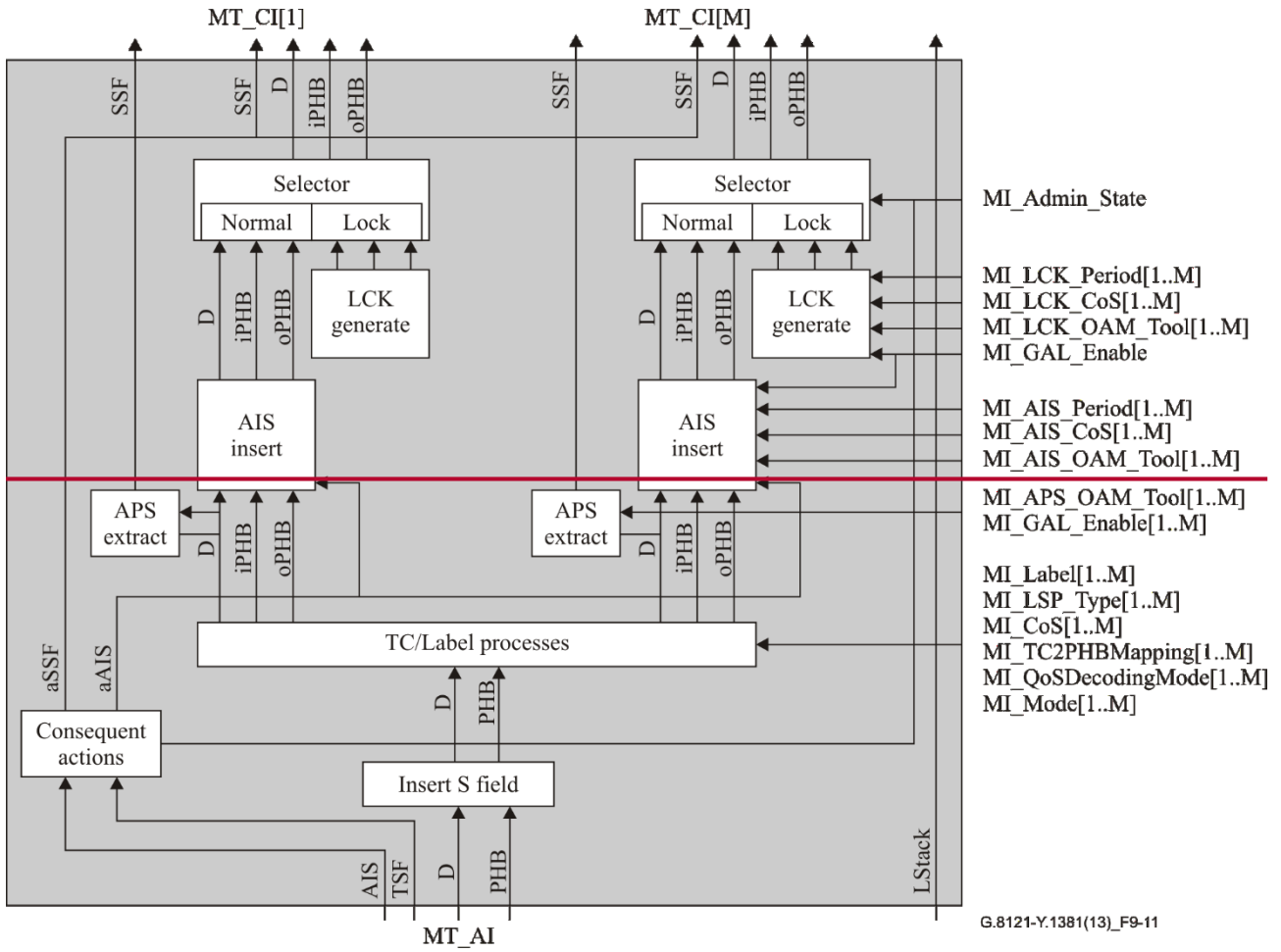
**Table 9-5/G.8121/Y.1381 – MT/MT\_A\_Sk interfaces**

Note: LStack behaviour should be reconfirmed

Inputs	Outputs
<p><b>MT_AP:</b>            MT_AI_Data            MT_AI_PHB            MT_AI_TSF  <u>MT_AI_TSD</u>            MT_AI_AIS            MT_AI_LStack</p> <p><b>MT/MT_A_Sk_MP:</b>            MT/MT_A_Sk_MI_Active            MT/MT_A_Sk_MI_AdminState            MT/MT_A_Sk_MI_Label[1...M]            MT/MT_A_Sk_MI_LSPTType[1...M]            MT/MT_A_Sk_MI_CoS[1...M]            MT/MT_A_Sk_MI_TC2PHBMapping[1...M]            MT/MT_A_Sk_MI_QoSDecodingMode[1...M]            MT/MT_A_Sk_MI_Mode</p> <p>MT/MT_A_Sk_MI_AIS_Period[1...M]            MT/MT_A_Sk_MI_AIS_CoS[1...M]            MT/MT_A_Sk_MI_AIS_OAM_Tool[1...M]            MT/MT_A_Sk_MI_LCK_Period[1...M]            MT/MT_A_Sk_MI_LCK_CoS[1...M]            MT/MT_A_Sk_MI_LCK_OAM_Tool[1...M]            MT/MT_A_Sk_MI_APS_OAM_Tool</p> <p>MT/MT_A_Sk_MI_GAL_Enable [1...M]</p>	<p><b>Each MT_CP:</b>            MT_CI_Data            MT_CI_iPHB            MT_CI_oPHB  <u>MT_CI_LStack</u>  <u>MT_CI_SSF</u></p> <p><b>MT_CP[1]:</b>  <del>MT_CI_Lstack</del>  <u>MT_CI_SSD[1]</u>  <u>MT_CI_APS[1]</u></p>

**Processes:**

The processes associated with the MT/MT\_A\_Sk function are as depicted in Figure 9-11.



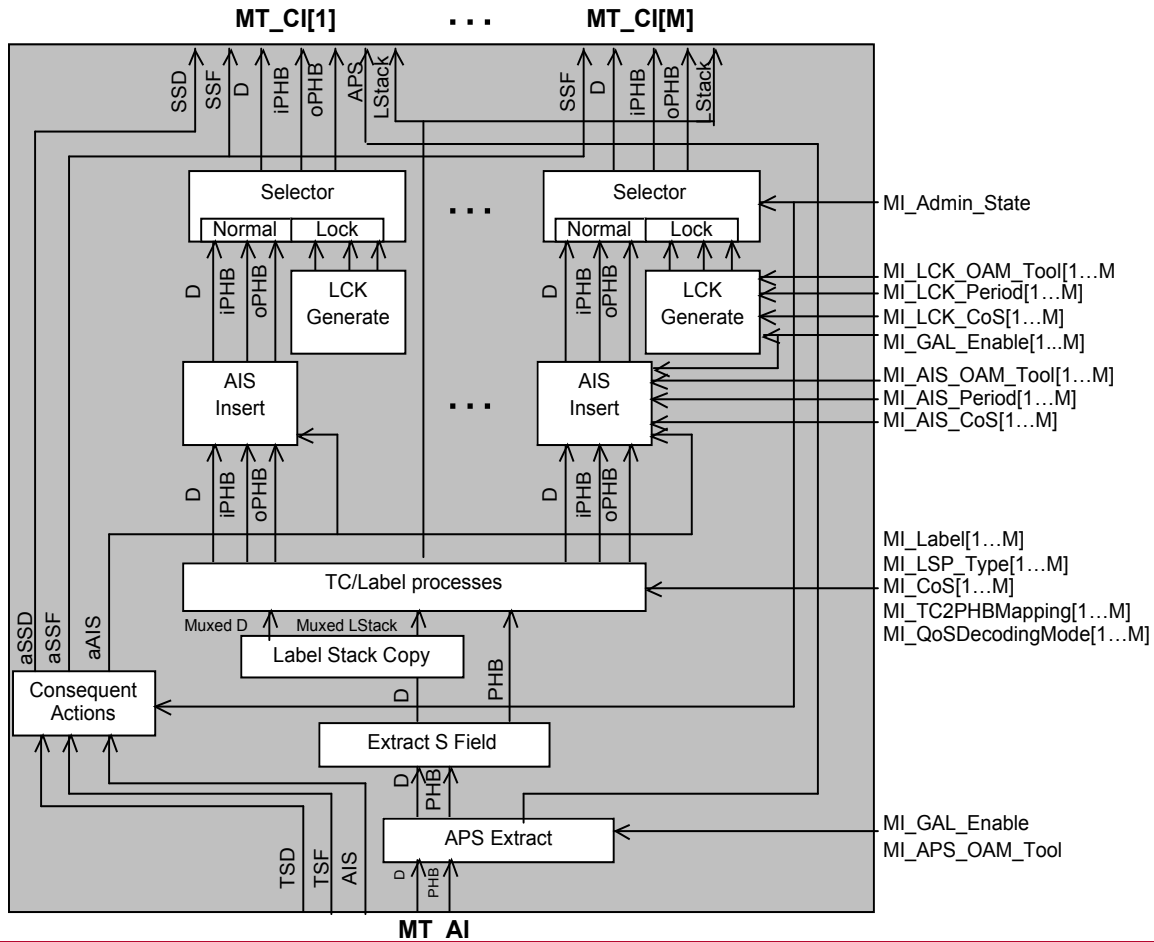


Figure 9-11/G.8121/Y.1381 – MT/MT\_A\_Sk process diagram

Note: LStack behaviour should be reconfirmed

- ~~==== Add CI APS output from APS Extract block to MT\_CI[1]?~~
- ~~==== Add AI TSD input to Consequent Action from MT\_AI~~
- ~~==== Add aSSD output from Consequent Action to MT\_CI[1]~~

– Selector process:

See 8.6.1. The normal CI is blocked if Admin\_State = LOCKED.

– LCK Generate process:

See 8.6.3.

– AIS process:

See 8.6.2.

– TC/Label processes:

See 8.2.2.

– Label Stack Copy processes:

See 8.2.3.

– S field extraction:

Extract and process the 1-bit S Field : the retrieved S Field should have the value 0 (not bottom of label stack) to indicate the client is MPLS; for such case the traffic unit is accepted and forwarded (together with the PHB information) after extraction of the S-bit field to the next process. For the case the S-bit has the value 1, the traffic unit is silently discarded.

. – APS Extract processes:

See 8.7.2.2.

• **Defects:**

*None.*

• **Consequent actions:**

The function shall perform the following consequent actions:

aSSF ← AI\_TSF

aSSD ← AI\_TSD

aAIS ← AI\_AIS

• **Defect correlations:**

*None.*

• **Performance monitoring:**

*None.*

**9.3.2 MPLS-TP to MPLS-TP adaptation function for Trail Protection (MT/MTp A)**

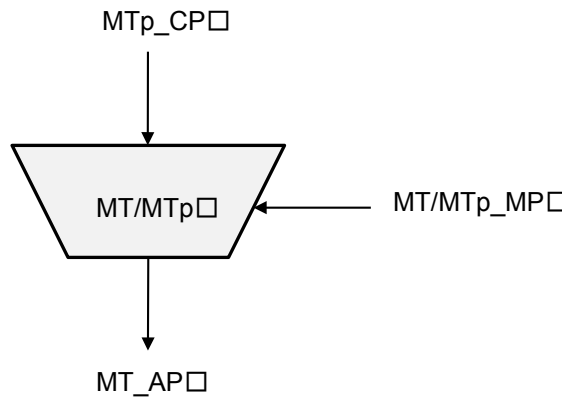
The MT/MTp\_A function is used for trail protection.

The bidirectional MT/MTp\_A is performed by a co-located pair of MT/MTp\_A source (MT/MTp\_A So) and sink (MT/MTp\_A Sk) functions.

**9.3.2.1 MPLS-TP to MPLS-TP adaptation source function for Trail Protection (MT/MTp A So)**

• **Symbol:**

The MT/MTp\_A So function symbol is shown in Figure 9-11x+1. This function maps client MTp\_CI traffic units into server MT\_AI traffic units.



**Figure 9-11x+1/G.8121/Y.1381 – MT/MTp A So function**

**• Interfaces:**

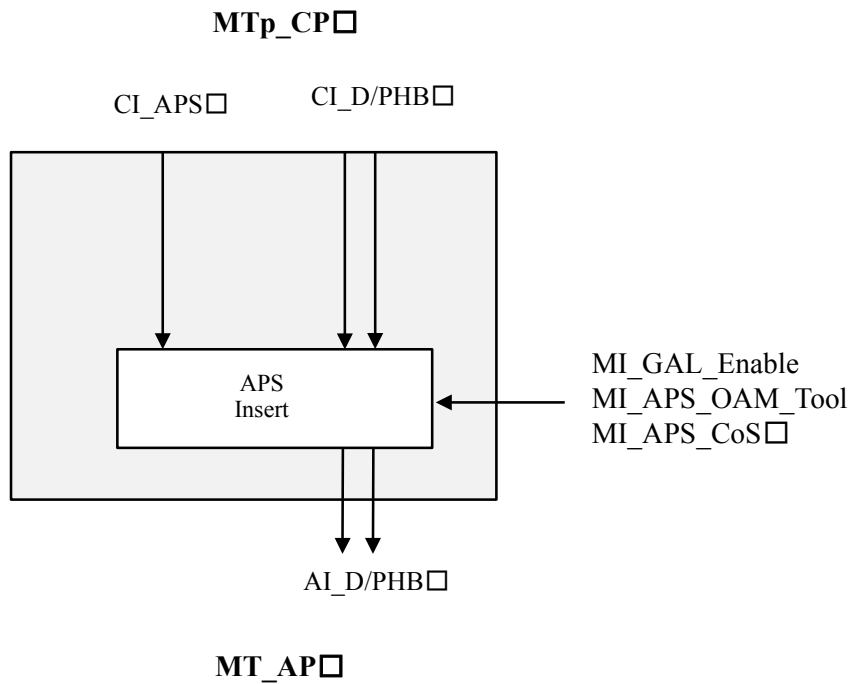
**Table 9-5x+1/G.8121/Y.1381 – MT/MTp A So interfaces**

<b><u>Inputs</u></b>	<b><u>Outputs</u></b>
<p><b><u>MT CP:</u></b>  <u>MTp_CI_Data</u>  <u>MTp_CI_PHB</u>  <u>MTp_CI_APS</u></p> <p><b><u>MT/MTp A So MI:</u></b>  <u>MT/MTp A So MI Active</u>  <u>MT/MTp A So MI GAL Enable</u>  <u>MT/MTp A So MI APS CoS</u>  <u>MT/MTp A So MI APS OAM Tool</u></p>	<p><b><u>MT AP:</u></b>  <u>MT_AI_Data</u>  <u>MT_AI_PHB</u></p>

**• Processes:**

The processes associated with the MT/MTp\_TT\_So function are as depicted in [Figure 9-11x+2](#).





**Figure 9-11x+2/G.8121/Y.1381 – MT/MTp A So process diagram**

– APS Insert process:

See 8.7.2.1.

**• Defects:**

None.

**• Consequent actions:**

None.

**• Defect correlations:**

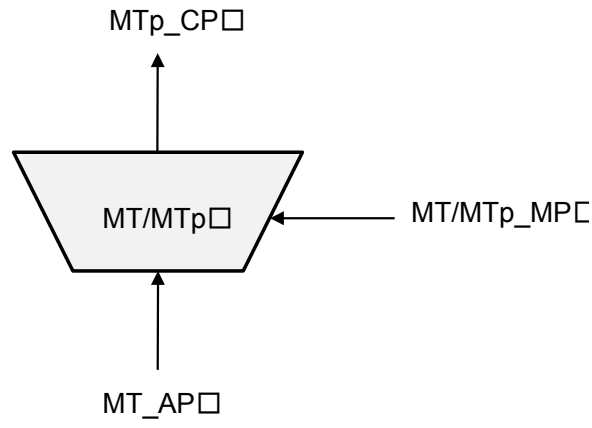
None.

**• Performance monitoring:**

None.

**9.3.2.21 MPLS-TP to MPLS-TP adaptation sink function for Trail Protection (MT/MTp A Sk)**

The MT/MTp\_A\_Sk function symbol is shown in Figure 9-11x+3. This function retrieves client MTp\_CI traffic units from server MT\_AI traffic units.



**Figure 9-11x+3/G.8121/Y.1381 – MT/MTp A Sk function**

**• Interfaces:**

**Table 9-5x+2/G.8121/Y.1381 – MT/MTp A Sk interfaces**

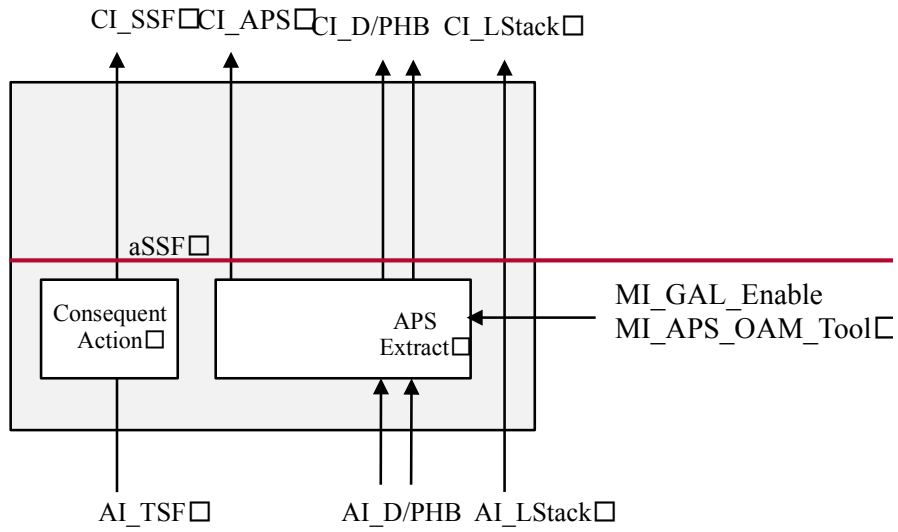
<u>Inputs</u>	<u>Outputs</u>
<p><b><u>MT AP:</u></b>  <u>MT_AI_Data</u>  <u>MT_AI_PHB</u>  <u>MT_AI_TSF</u>  <u>MT_AI_TSD</u>  <u>MT_AI_AIS</u>  <u>MT_AI_LStack</u></p> <p><b><u>MT/MTp A Sk MP:</u></b>  <u>MT/MTp_A_Sk_MI_Active</u>  <u>MT/MTp_A_Sk_MI_APS_OAM_Tool</u>  <u>MT/MTp_A_Sk_MI_GAL_Enable</u></p>	<p><b><u>MTp CP:</u></b>  <u>MTp_CI_Data</u>  <u>MTp_CI_PHB</u>    <u>MTp_CI_SSF</u>  <u>MTp_CI_SSD</u>  <u>MTp_CI_AIS</u>  <u>MTp_CI_LStack</u>  <u>MTp_CI_APS</u></p>

[Note: See SP#15, LL]

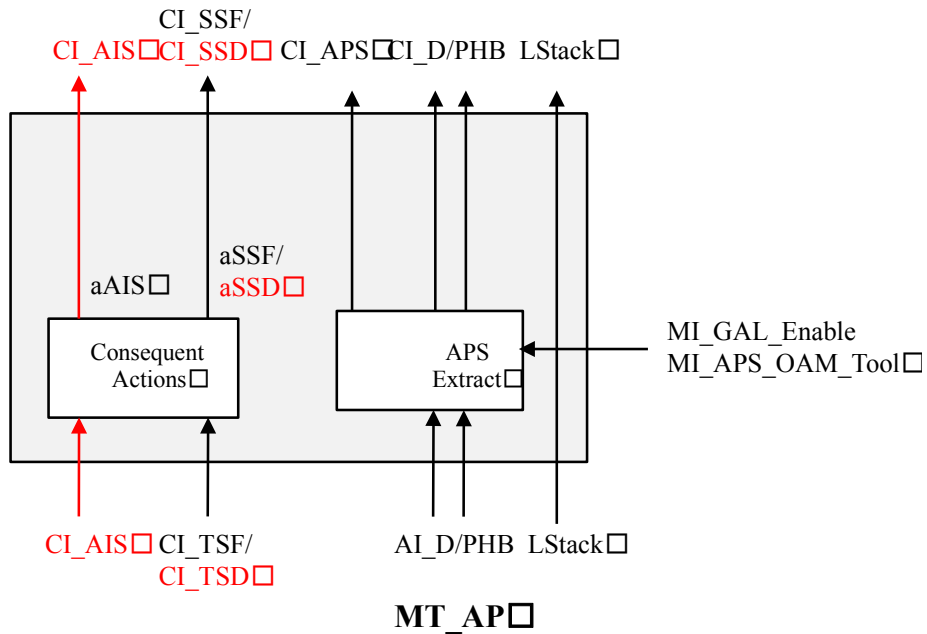
**Processes:**

The processes associated with the MT/MTp A Sk function are as depicted in Figure 9-11x+4.

### MTp\_CP



### MT\_AP



**Figure 9-11x+4/G.8121/Y.1381 – MT/MTp A Sk process diagram**

**Note: Update Figure 9-11x+4 as follows:**

- Add AI TSD input and CI SSD output to the Consequent Action block.**
- Add AI AIS input and CI AIS output to the Consequent Action block.**

– APS Extract process:

See 8.7.2.2.

• **Defects:**

None.

• **Consequent actions:**

The function shall perform the following consequent actions:

aSSF ← AI\_TSF

aSSD ← AI\_TSD

aAIS ← AI\_AIS

• **Defect correlations:**

None.

• **Performance monitoring:**

None.

## 9.4 MT Diagnostic Function

### 9.4.1 MT Diagnostic Functions for MEPs (MTDe)

#### 9.4.1.1 MT Diagnostic Trail Termination Functions for MEPs (MTDe\_TT)

The bidirectional MTDe Trail Termination (MTDe\_TT) function is performed by a co-located pair of MTDe trail termination source (MTDe\_TT\_So) and sink (MTDe\_TT\_Sk) functions as shown in Figure 9-12.

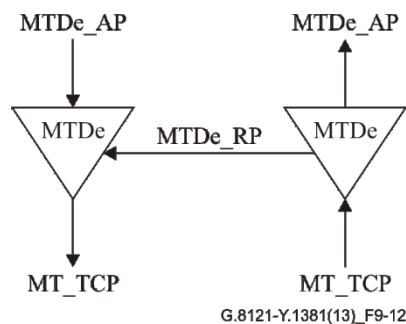


Figure 9-12/G.8121/Y.1381 – MTDe\_TT

#### 9.4.1.1.1 MT Diagnostic Trail Termination Source Function for MEPs (MTDe\_TT\_So)

##### Symbol

The MTDe\_TT\_So function symbol is shown in Figure 9-13.

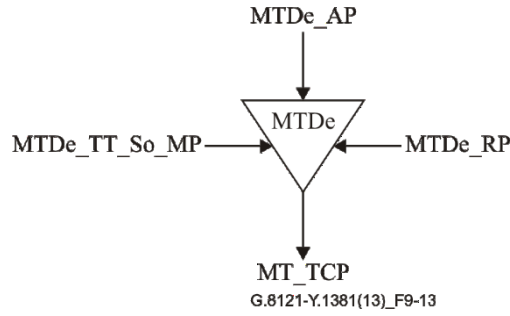


Figure 9-13/G.8121/Y.1381– MTDe\_TT\_So symbol

**Interfaces**

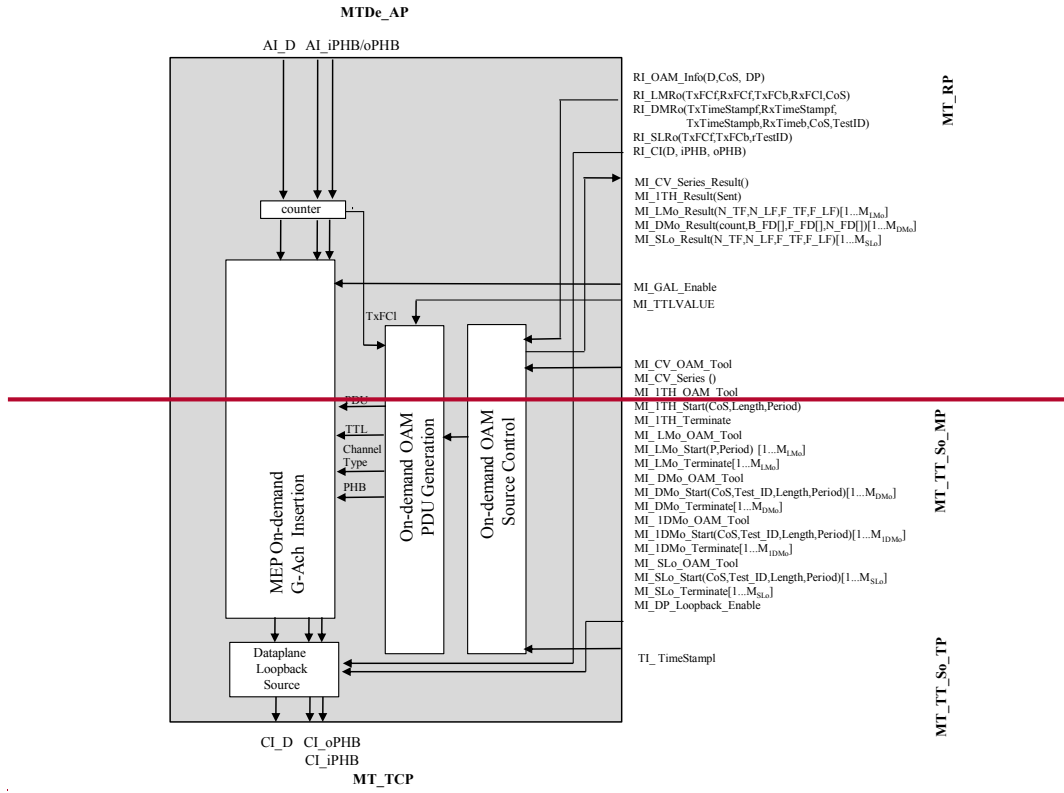
Table 9-6/G.8121/Y.1381 – MTDe\_TT\_So interfaces

Input(s)	Output(s)
<p><b>MTDe_AP:</b> MTDe_AI_D MTDe_AI_oPHB MTDe_AI_iPHB</p> <p><b>MTDe_RP:</b> MTDe_RI_OAM_Info(D,CoS,DP) MTDe_RI_CI</p> <p><b>MTDe_TT_So_MP:</b> MTDe_TT_So_MI_GAL_Enable MTDe_TT_So_MI_TTLVALUE MTDe_TT_So_MI_CV_OAM_Tool MTDe_TT_So_MI_CV_Series () [Note]</p> <p>MTDe_TT_So_MI_1TH_OAM_Tool MTDe_TT_So_MI_1TH_Start (CoS,Length,Period) MTDe_TT_So_MI_1TH_Terminate</p> <p>MTDe_TT_So_MI_LMo_OAM_Tool MTDe_TT_So_MI_LMo_Start(CoS,Period) [1...M<sub>LMo</sub>] <a href="#">MTDe_TT_So_MI_LMo_Intermediate_Request[1...M<sub>LMo</sub>]</a> MTDe_FT_So_MI_LMo_Terminate[1...M<sub>LMo</sub>]</p> <p>MTDe_TT_So_MI_DMo_OAM_Tool MTDe_TT_So_MI_DMo_Start (CoS,Test_ID,Length,Period)[1...M<sub>DMo</sub>] <a href="#">MTDe_TT_So_MI_DMo_Intermediate_Request[1...M<sub>DMo</sub>]</a> MTDe_TT_So_MI_DMo_Terminate[1...M<sub>DMo</sub>]</p> <p>MTDe_TT_So_MI_1DMo_OAM_Tool MTDe_TT_So_MI_1DMo_Start (CoS,Test_ID,Length,Period)[1...M<sub>1DMo</sub>] MTDe_TT_So_MI_1DMo_Terminate[1...M<sub>1DMo</sub>]</p>	<p><b>MT_TCP:</b> MT_CI_D MT_CI_oPHB MT_CI_iPHB</p> <p><b>MTDe_TT_So_MP:</b> MTDe_TT_So_MI_CV_Series_Result[Note] MTDe_TT_So_MI_1TH_Result(Sent) MTDe_TT_So_MI_LMo_Result(N_TF,N_LF,F_TF,F_LF)[1...M<sub>LMo</sub>] MTDe_TT_So_MI_DMo_Result(count,B_FD[],F_FD[],N_FD[])[1...M<sub>DMo</sub>] MTDe_TT_So_MI_SLo_Result(N_TF,N_LF,F_TF,F_LF)[1...M<sub>SLo</sub>]</p>

<p>MTDe_TT_So_MI_SLo_OAM_Tool MTDe_TT_So_MI_SLo_Start (CoS,Test_ID,Length,Period)[1...M<sub>SLo</sub>] <a href="#">MTDe_TT_So_MI_SLo_Intermediate_Request[1...M<sub>LMo</sub></a> ↓ MTDe_TT_So_MI_SLo_Terminate[1...M<sub>SLo</sub>] MTDe_TT_So_MI_Admin_State MTDe_TT_So_MI_Lock_Instruct_Enable  MTDe_TT_So_MI_DP_Loopback_Enable  <b>MTDe_TT_So_TP:</b> MTDe_TT_So_TI_TimeStamp</p>	
<p><i>Note: The parameters for MI_CV_Series and MI_CV_Series_Result are not within the scope of this Recommendation</i></p>	

## Processes

The processes associated with the MTDe\_TT\_So function are as depicted in Figure 9-14.



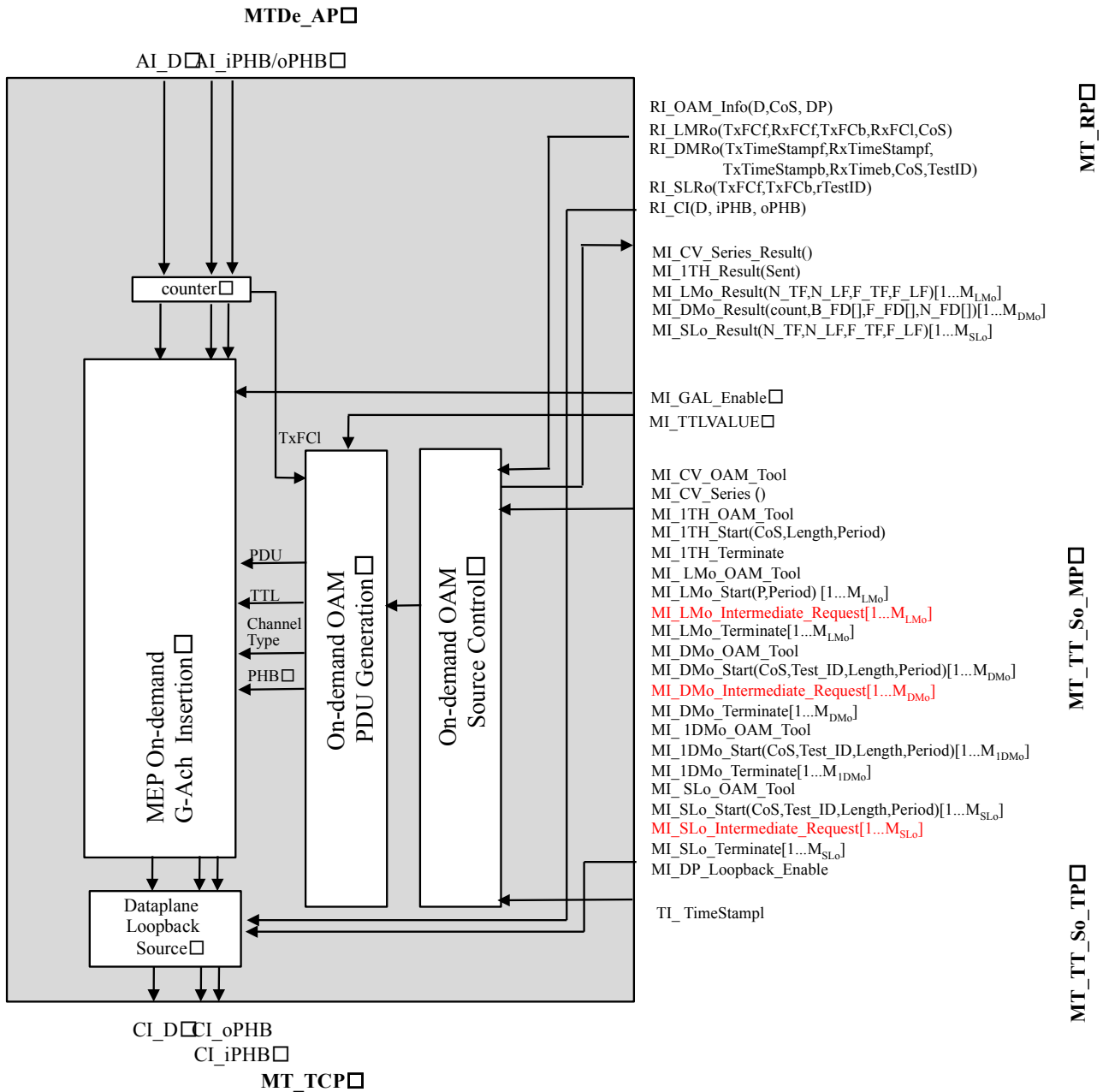


Figure 9-14/G.8121/Y.1381 – MTDe\_TT\_So Process

**MEP On-demand G-ACh Insertion:** See clause 8.1.

**OAM PDU Generation:** See clause 8.8

**On-demand OAM Source Control:** See clause 8.8

**Dataplane Loopback Source process:** See clause 8.9.1

**Counter:** [This process is used to count packets for on-demand loss measurements. The location of the counter process is shown for illustration only. The exact set of packets to be counted is outside of the scope in this Recommendation.](#)



<b>Defects</b>	None
<b>Consequent actions</b>	None
<b>Defect correlations</b>	None
<b>Performance monitoring</b>	None

#### 9.4.1.1.2 MT Diagnostic Trail Termination Sink Function for MEPs (MTDe\_TT\_Sk)

##### Symbol

The MTDe\_A\_Sk function symbol is shown in Figure 9-15.

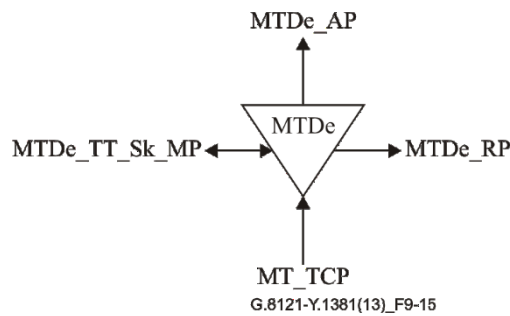


Figure 9-15/G.8121/Y.1381 – MTDe\_TT\_Sk symbol

##### Interfaces

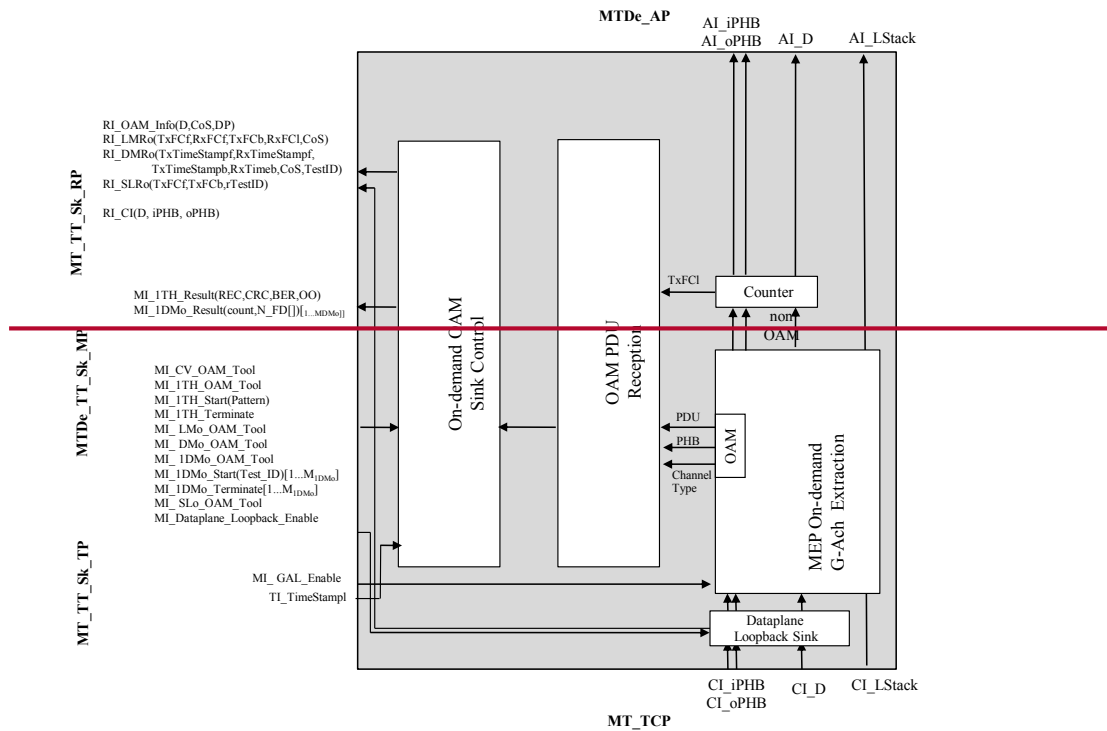
Table 9-7/G.8121/Y.1381 – MTDe\_TT\_Sk interfaces

Input(s)	Output(s)
<p><b>MT_TCP:</b>            MT_CI_D            MT_CI_iPHB            MT_CI_oPHB            MT_CI_LStack</p> <p><b>MTDe_TT_Sk_MP:</b>            MTDe_TT_Sk_MI_GAL_Enable            MTDe_TT_Sk_MI_CV_OAM_Tool            MTDe_TT_Sk_MI_1TH_OAM_Tool            MTDe_TT_Sk_MI_1TH_Start            MTDe_TT_Sk_MI_1TH_Terminate            MTDe_TT_Sk_MI_LMo_OAM_Tool            MTDe_TT_Sk_MI_DMo_OAM_Tool            MTDe_TT_Sk_MI_1DMo_OAM_Tool            MTDe_TT_Sk_MI_1DMo_Start(Test_ID,  <u>CoS</u>)[1...M<sub>1DMo</sub>]  <u>MTDe_TT_Sk_MI_1DMo_Intermediate_Request</u>[1            ...M<sub>1DMo</sub>]            MTDe_TT_Sk_MI_1DMo_Terminate[1...M<sub>1DMo</sub>]</p>	<p><b>MTDe_AP:</b>            MTDe_AI_D            MTDe_AI_oPHB            MTDe_AI_iPHB            MTDe_AI_LStack</p> <p><b>MTDe_RP:</b>            MTDe_RI_OAM_Info(D,CoS,DP)             MTDe_RI_CI</p> <p><b>MTDe_TT_Sk_MP:</b>            MTDe_TT_Sk_MI_1TH_Result(REC,CRC,BER,O            O)            MTDe_TT_Sk_MI_1DMo_Result(count,N_FD[])[1            ...M<sub>1DMo</sub>]            MTDe_TT_Sk_MI_Admin_State_Request</p>

Input(s)	Output(s)
MTDe_TT_Sk_MI_SLo_OAM_Tool MTDe_TT_Sk_MI_DP_Loopback_Enable  <b>MTDe_TP:</b> MTDe_TT_Sk_TI_TimeStamp!	

## Processes

The processes associated with the MTDe\_TT\_Sk function are as depicted in Figure 9-16.



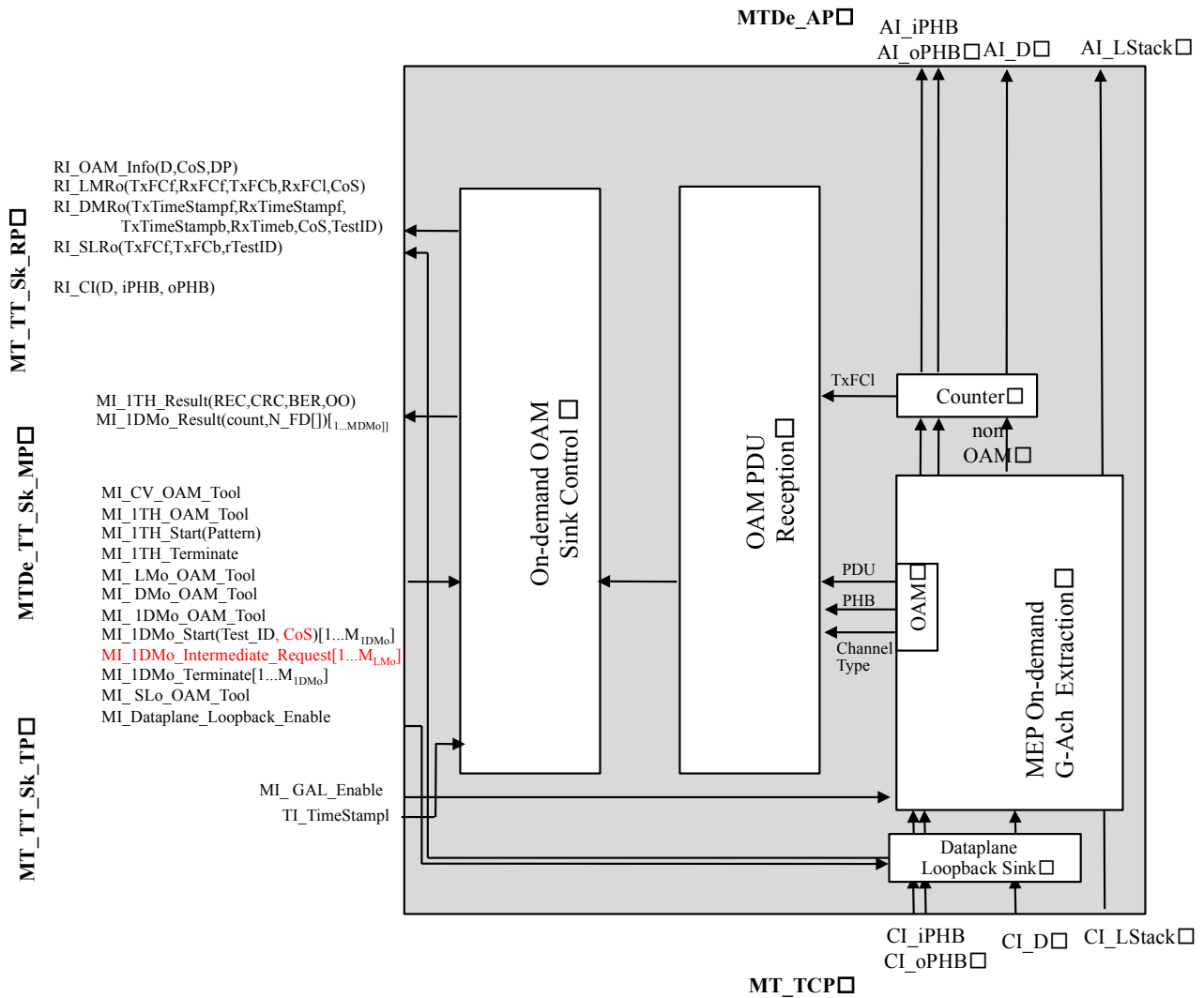


Figure 9-16/G.8121/Y.1381 – MTDe\_TT\_Sk Process

**MEP On-demand G-ACh Extraction** See 8.1 The process of CI\_D is made according to the following rule:

```

if ( ((MI_GAL_Enable && MT-label(D) == GAL) ||
      (!MI_GAL_Enable && 1stNibble(D) == 0b0001)) &&
      (Packet_Type(D) == On-demand_OAM) )
    forward to G-ACh port
} else {
    forward to data port
}

```

Note: MT-label(D) and 1stNibble(D) are functions which return, respectively, the Label field at the top of the stack within the MPLS payload, the first nibble of the MPLS payload as defined in Figure 6-3/G.8110.1.

These fields are used to identify G-ACh packets as described in section 4.2.1 of [RFC 5586].

Packet\_Type(D) is a protocol-specific function that determines whether the Traffic Unit contains an on-demand OAM packet.

**OAM PDU Reception:** See clause 8.8

**On-demand OAM Sink Control:** See clause 8.8

**Dataplane Loopback Sink process:** See clause 8.9.2

[Counter: This process is used to count packets for on-demand loss measurements. The location of the counter process is shown for illustration only. The exact set of packets to be counted is outside of the scope in this Recommendation.](#)

<b>Defects</b>	None
<b>Consequent actions</b>	None
<b>Defect correlations</b>	None
<b>Performance monitoring</b>	None

#### 9.4.1.2 MTDe to MT Adaptation functions (MTDe/MT\_A)

##### 9.4.1.2.1 MTDe to MT Adaptation Source Function (MTDe/MT\_A\_So)

This function consists of input MT\_CI and output MTDe\_AI. The function inside is empty, i.e. the input signals are simply passes to the output.

[\[Need some text for MI\\_Active?\]](#)

##### 9.4.1.2.2 MTDe to MT Adaptation Sink Function (MTDe/MT\_A\_Sk)

This function consists of input MTDe\_AI and output MT\_CI. The function inside is empty, i.e. the input signals are simply passes to the output.

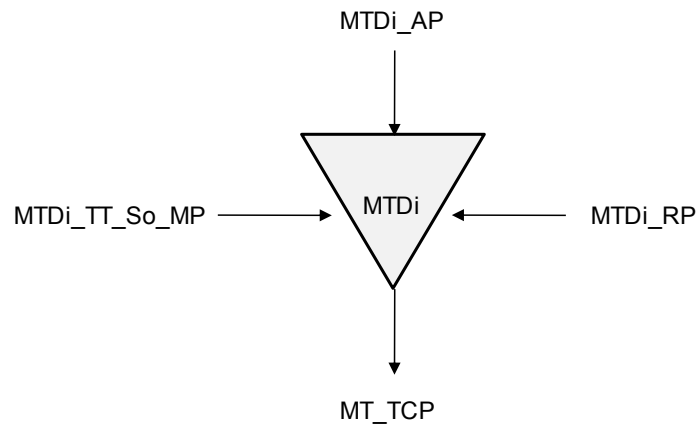
[\[Need some text for MI\\_Active?\]](#)

#### 9.4.2 MT Diagnostic Functions for MIPs (MTDi)

##### 9.4.2.1 MT Diagnostic Trail Termination Functions for MIPs (MTDi\_TT)

###### 9.4.2.1.1 MT Diagnostic Trail Termination Source Function for MIPs (MTDi\_TT\_So) Symbol

The MTDi\_TT\_So function symbol is shown in Figure 9-17



**Figure 9-17/G.8121/Y.1381 – MTDi\_TT\_So symbol**

**Interfaces**

**Table 9-8/G.8121/Y.1381 – MTDi\_TT\_So interfaces**

Inputs	Outputs
<p><b>MTDi_AP</b>            MTDi_AI_D            MTDi_AI_iPHB            MTDi_AI_oPHB            MTDi_AI_Lstack</p> <p><b>MTDi_RP</b>            MTDi_RI_OAM_Info (D, CoS, DP)            MTDi_RI_CI</p> <p><b>MTDi_TT_So_MP</b>            MTDi_TT_So_MI_GAL_Enable            MTDi_TT_So_MI_TTLVALUE            MTDi_TT_So_MI_MIP_ID            MTDi_TT_So_MI_CV_OAM_Tool            MTDi_TT_So_MI_DP_Loopback_Enable</p>	<p><b>MT_TCP</b>            MT_CI_D,            MT_CI_iPHB,            MT_CI_oPHB,            MT_CI_LStack</p>

**Processes**

The processes associated with the MTDi\_TT\_So function are as depicted in Figure 9-18.

## MTDi\_AP

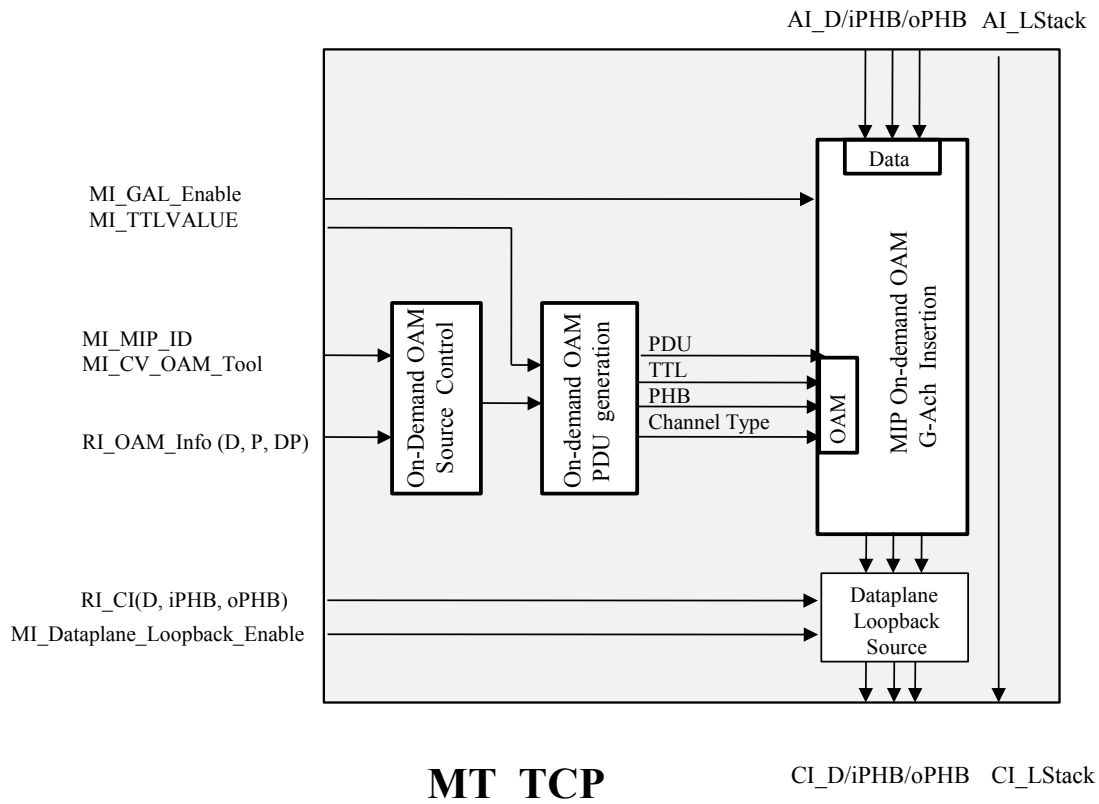


Figure 9-18/G.8121/Y.1381 – MTDi\_TT\_So Process

### MIP On-demand OAM G-ACh insertion:

The MIP OAM Insertion process inserts OAM Traffic Units that are generated in the MTDi\_TT\_So process into the stream of Traffic Units.

The GAL is used or not according to the MI\_GAL\_Enable parameter.

**OAM PDU Generation:** See clause 8.8.

**On-demand OAM Source Control:** See clause 8.8.

**Dataplane Loopback Source process:** See clause 8.9.1

**Defects** None.

**Consequent actions** None.

**Defect correlations** None.

**Performance monitoring** None.

### 9.4.2.1.2 MT Diagnostic Trail Termination Sink Function for MIPs (MTDi\_TT\_Sk)

#### Symbol

The MTDi\_TT\_Sk function symbol is shown in Figure 9-19.

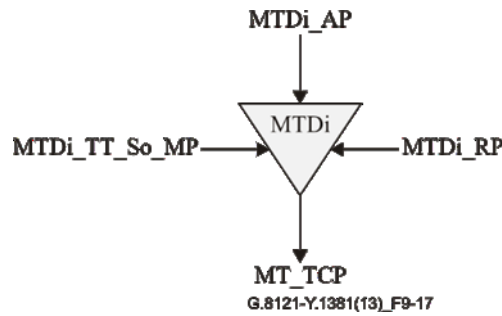


Figure 9-19/G.8121/Y.1381 – MTDi\_TT\_Sk symbol

#### Interfaces

Table 9-9/G.8121/Y.1381 – MTDi\_TT\_Sk interfaces

Inputs	Outputs
<b>MT_TCP</b> MT_CI_D MT_CI_iPHB MT_CI_oPHB MT_CI_LStack  <b>MTDi_TT_Sk_MP</b> MTDi_TT_Sk_MI_GAL_Enable MTDi_TT_Sk_MI_MIP_ID MTDi_TT_Sk_MI_CV_OAM_Tool MTDi_TT_Sk_MI_DP_Loopback_Enable	<b>MTDi_AP</b> MTDi_AI_D MTDi_AI_iPHB MTDi_AI_oPHB MTDi_AI_LStack  <b>MTDi_RP</b> MTDi_RI_OAM_Info (D, CoS, DP) MTDi_RI_CI

#### Processes

The processes associated with the MTDi\_TT\_Sk function are as depicted in Figure 9-20.

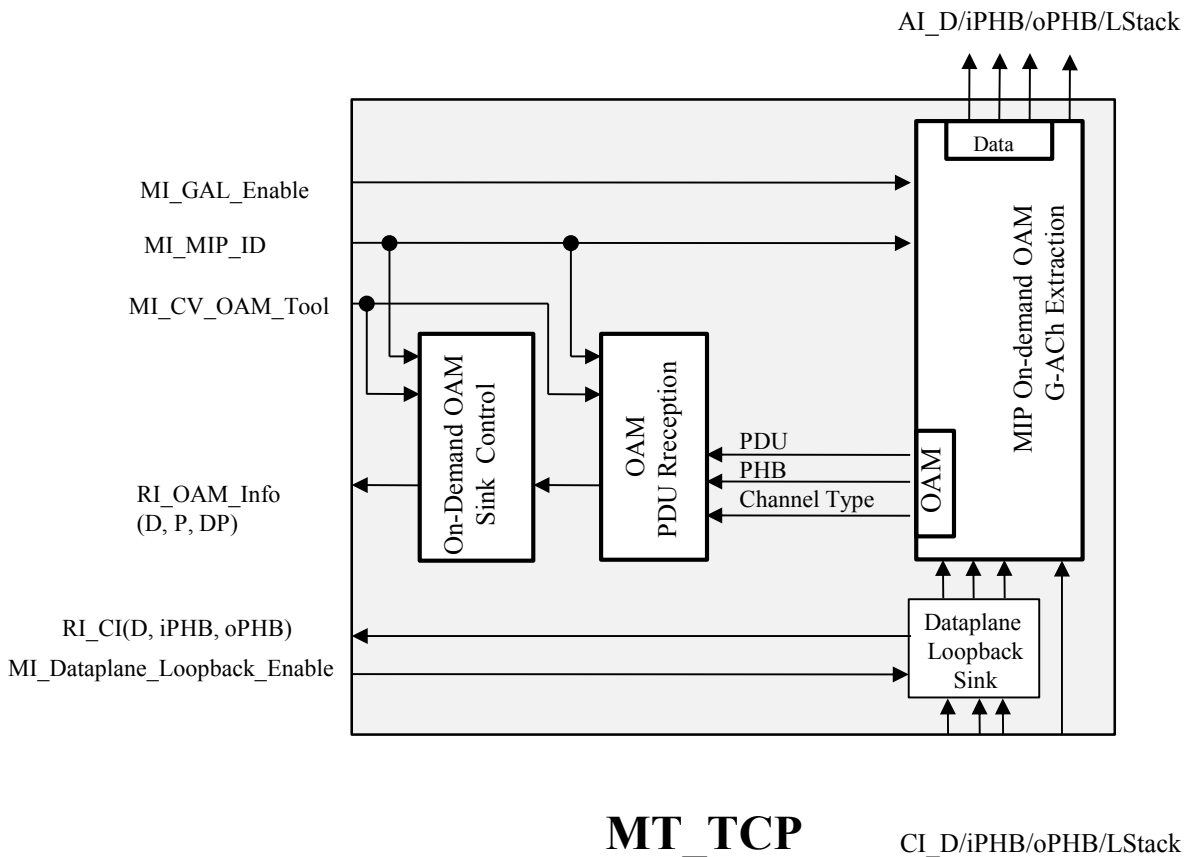


Figure 9-20/G.8121/Y.1381 – MTDi\_TT\_Sk Process

**MIP On-demand OAM G-ACh extraction:**

The MIP OAM Extraction process classifies the OAM traffic units targeted to the MIP to which this MTDi\_TT belongs, as configured by MI\_MIP\_ID, and delivers them to the On-demand OAM PDU Reception Process. All the other traffic units are delivered to MTDi\_AP. The process is made according to the following rule:

```

if ( (TTL(D) == 0) &&
      ((MI_GAL_Enable && MT-label(D) == GAL) ||
       (!MI_GAL_Enable && 1stNibble(D) == 0b0001)) &&
      (Packet_Type(D) == OnDemandForThisMIP) )
{
    forward to G-Ach port
} else {
    forward to data port
}

```

Note: For LSP and Pseudowire MIPs, MT-label(D), 1stNibble(D) and TTL(D) are functions which return, respectively, the Label field at the top of the stack within the MPLS payload, the first nibble of the MPLS payload and the TTL field as defined in Figure 6-3/G.8110.1.

These fields are used to identify G-ACh packets as described in section 4.2.1 of [RFC 5586].

Packet\_Type(D) is a protocol-specific function that determines whether the Traffic Unit contains a On-demand OAM packet be processed by this MIP.



**OAM PDU Reception:** See clause 8.8.

**On-demand OAM Sink Control:** See clause 8.8.

**Dataplane Loopback Sink process:** See clause 8.9.2

**Defects**                      None.

**Consequent actions**      None.

**Defect correlations**        None.

**Performance monitoring**   None.

### 9.4.2.2 MTDi to MT Adaptation functions (MTDi/MT\_A)

The MTDi/MT adaptation function is an empty function; it is included to satisfy the modelling rules.

The bidirectional MTDi/MT adaptation function is performed by a co-located pair of MTDi/MT adaptation source (MTDi/MT\_A\_So) and sink (MTDi/MT\_A\_Sk) functions.

[Need some text for MI\_Active?]

#### 9.4.2.2.1 MTDi to MT adaptation source functions (MTDi/MT\_A\_So)

##### Symbol

The MTDi/MT\_A\_So function symbol is shown in Figure 9-21.

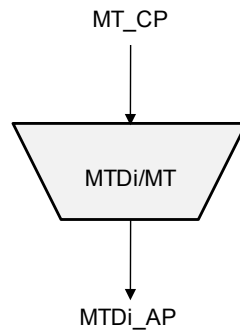


Figure 9-21/G.8121/Y.1381 – MTDi/MT\_A\_So symbol

##### Interfaces

Table 9-10 – MTDi/MT\_A\_So interfaces

Inputs	Outputs
<b>MT_CP:</b> MT_CI_D MT_CI_iPHB MT_CI_oPHB MT_CI_LStack MI_Active	<b>MTDi_AP:</b> MTDi_AI_D MTDi_AI_iPHB MTDi_AI_oPHB MTDi_AI_LStack

##### Processes

The processes associated with the MTDi/MT\_Sk function are as depicted in Figure 9-22.

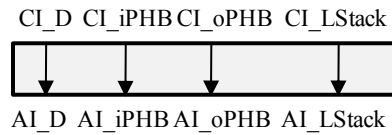


Figure 9-22/G.8121/Y.1381 – MTDi/MT\_A\_So Process

add MI Active

<b>Defects</b>	None.
<b>Consequent Actions</b>	None.
<b>Defect correlations</b>	None.
<b>Performance Monitoring</b>	None.

#### 9.4.2.2.2 MTDi to MT adaptation sink function (MTDi/MT\_A\_Sk)

##### Symbol

The MTDi/MT\_A\_So function symbol is shown in Figure 9-23.

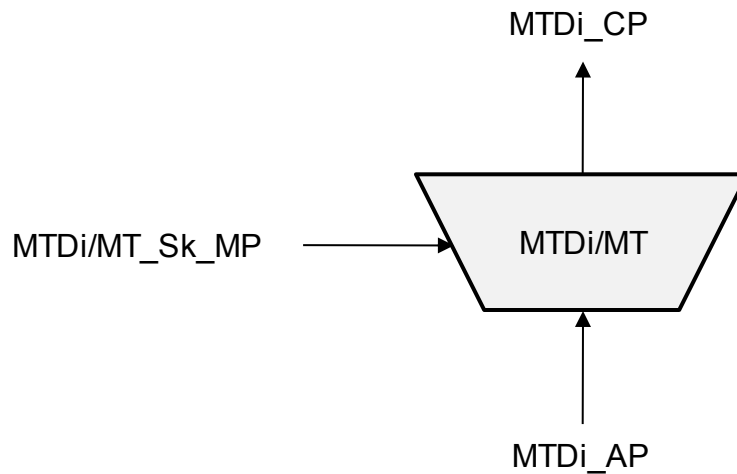


Figure 9-23/G.8121/Y.1381 – MTDi/MT\_A\_Sk symbol

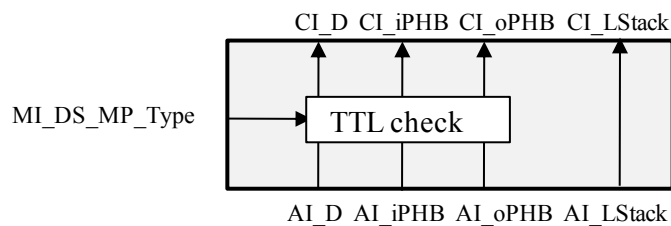
##### Interfaces

**Table 9-11/G.8121/Y.1381 –MTDi/MT\_A\_Sk interfaces**

Inputs	Outputs
<b>MTDi_AP:</b> MTDi_AI_D MTDi_AI_iPHB MTDi_AI_oPHB MTDi_AI_LStack MI_Active?  <b>MTDi/MT_Sk_MP:</b> MIDi/MT_A_MI_DS_MP_Type	<b>MT_CP:</b> MT_CI_D MT_CI_iPHB MT_CI_oPHB MT_CI_LStack

**Processes**

The processes associated with the MTDi/MT\_A\_Sk function are as depicted in Figure 9-24.



**Figure 9-24/G.8121/Y.1381 – MTDi/MT\_A\_Sk Process**

[add MI\_Active]

*TTL check process:*

For LSP and Pseudowire MIPs, the TTL Check process examines the TTL field in the MTDi\_AI\_D traffic unit. TTL check process drops all MPLS-TP packets with TTL = 0 by default (MI\_DS\_MP\_Type set to none).

When MI\_DS\_MP\_Type is set to MIP, TTL check process drops only user data MPLS-TP packets with TTL = 0 while OAM packets with TTL = 0 are not dropped in this process and forwarded.

When the MI\_DS\_MP\_Type is set to MEP, TTL check process does not block any MPLS-TP packet with TTL = 0: all MPLS-TP packets with TTL = 0 are forwarded.

NOTE – The MI\_DS\_MP\_Type parameter should be properly configured by the EMF on the basis of the MPLS-TP connection configuration within the node and not exposed to the operator as a configuration parameter of the Equipment Management Interface. Examples of MI\_DS\_MP\_Type configuration are described in Appendix I.

**Defects** None.

**Consequent Actions** None.

**Defect correlations** None.

**Performance Monitoring** None.

## 9.5 MPLS-TP MEP and MIP functions

[Note: This clause provides new text since G.8121(2013)]

MEP and MIP compound functions are defined in [ITU-T G.806]. This clause specifies the composition of those functions with MT termination, adaptation and diagnostic atomic functions described in clauses 9.2, 9.3 and 9.4, respectively.

### 9.5.1 MPLS-TP NCM MEP function

An MPLS-TP NCM (network connection monitoring) MEP function is capable of originating, filtering and terminating proactive MPLS-TP OAM signals and originating, responding to and terminating diagnostic MPLS-TP OAM signals at the MPLS-TP layer. The NCM MEP is composed of MT\_TT, MTDe/MT\_A and MTDe\_TT atomic functions. This MEP is located at the MPLS-TP layer boundary and connected with MT/client\_A or MT/MT\_A.

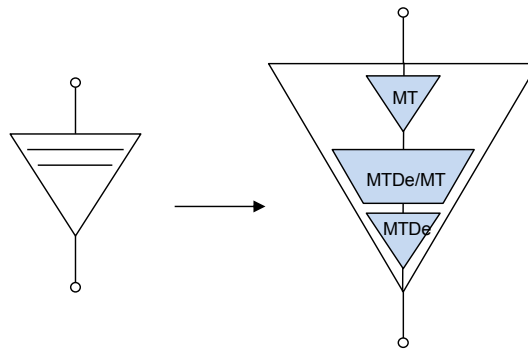
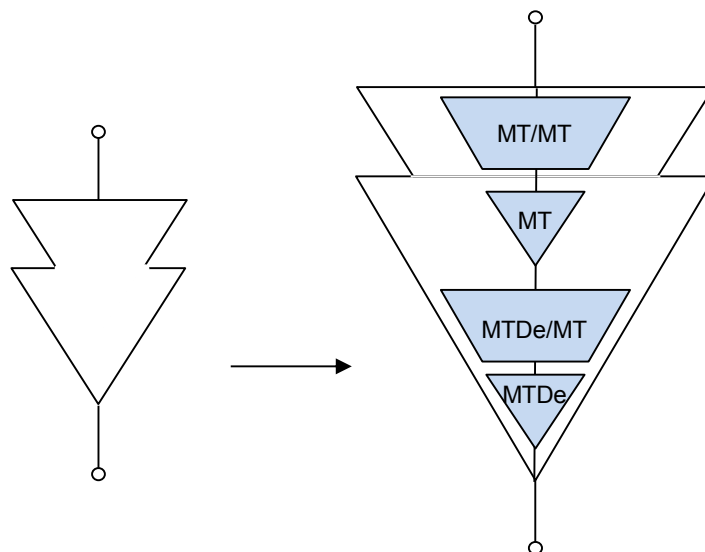


Figure 9-25 – MT NCM MEP compound functions

### 9.5.2 MPLS-TP TCM MEP function

Tandem Connection Monitoring (TCM) can be supported by the instantiation of Sub-Path Maintenance Entity (SPME), as described in [IETF RFC 6371], that has a 1:1 relationship with the monitored connection.

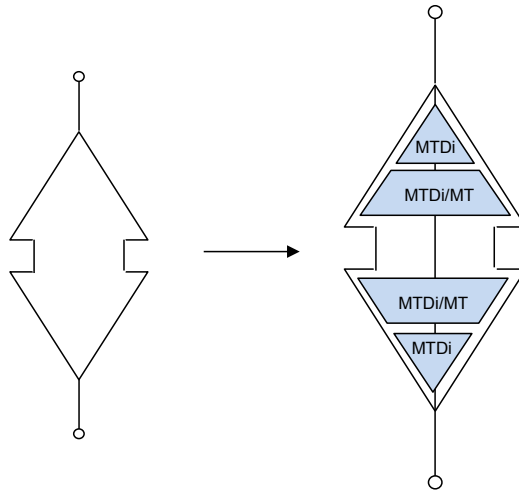
An MPLS-TP TCM MEP function is capable of originating, filtering and terminating proactive MPLS-TP OAM signals and originating, responding to and terminating diagnostic MPLS-TP OAM signals at MPLS-TP sub-layer. The TCM MEP is composed of composed of MT\_TT, MTDe/MT\_A and MTDe\_TT atomic functions.



**Figure 9-26 – MT TCM MEP compound functions**

### 9.5.3 MT MIP function

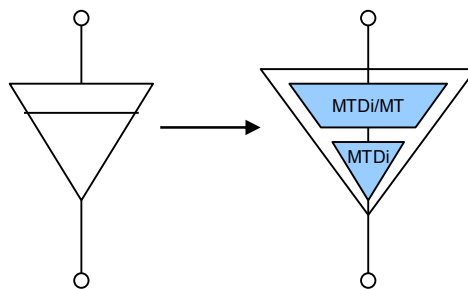
An MT MIP function is capable of responding to on-demand MT OAM signals at one of the MPLS-TP (sub-)layers in both directions. The MIP combines two back-to-back half-MIP functions. It consists of two pairs of MTDi/MT\_A and MTDi\_TT atomic functions, each facing opposite directions



**Figure 9-27 – MT MIP compound functions**

### 9.5.4 MT half MIP function

An MPLS-TP half MIP function is capable of responding to on-demand MPLS-TP OAM signals at one of the MPLS-TP sublayers in a single direction. The half MIP is composed of a pair of MTDi/MT\_A and MTDi\_TT atomic functions.



**Figure 9-28 – MT half MIP compound functions**

**10 MPLS-TP to Non-MPLS-TP client adaptation functions**

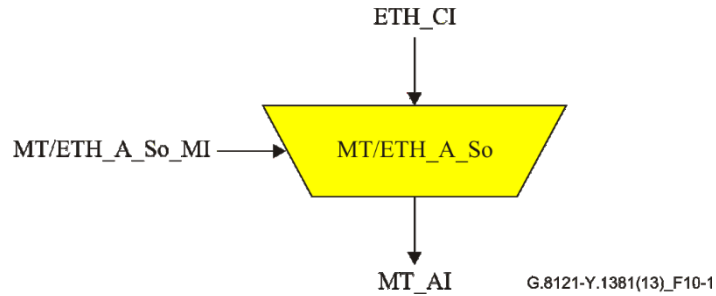
**10.1 MPLS-TP to ETH adaptation function (MT/ETH\_A)**

**10.1.1 MPLS-TP to ETH adaptation source function (MT/ETH\_A\_So)**

This function maps the ETH\_CI information for transport in an MT\_AI signal.

The information flow and processing of the MT/ETH\_A\_So function is defined with reference to Figure 10-1.

**• Symbol:**



**Figure 10-1/G.8121/Y.1381 – MT/ETH\_A\_So function**

**• Interfaces:**

**Table 10-1/G.8121/Y.1381 – MT/ETH\_A\_So Inputs and Outputs**

Inputs	Outputs
<p><b>ETH_FP:</b> ETH_CI_Data ETH_CI_P ETH_CI_DE</p> <p><b>MT/ETH_A_So_MP:</b> MT/ETH_A_So_MI_Active MT/ETH_A_So_MI_AdminState MT/ETH_A_So_MI_FCSEnable MT/ETH_A_So_MI_CWEnable MT/ETH_A_So_MI_SQUse MT/ETH_A_So_MI_PRI2CoSMapping MT/ETH_A_So_MI_MEP_MAC* MT/ETH_A_So_MI_Client_MEL* MT/ETH_A_So_MI_LCK_Period* MT/ETH_A_So_MI_LCK_Pri* MT/ETH_A_So_MI_MEL* * ETH OAM related</p>	<p><b>MT_AP:</b> MT_AI_Data MT_AI_PHB</p>

**Processes:**

The processes associated with the MT/ETH\_A\_So function are as depicted in Figure 10-2.

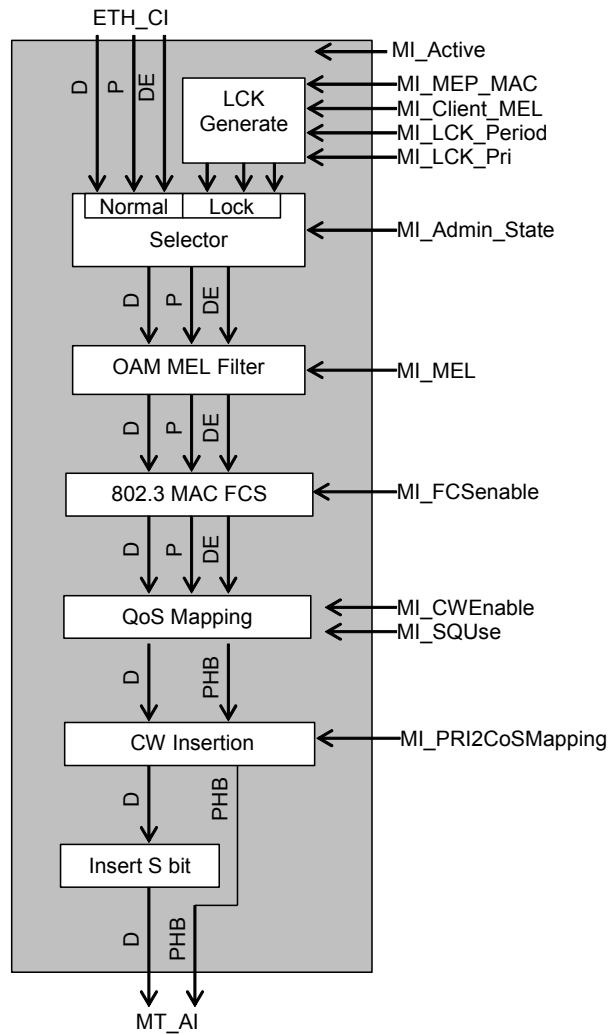


Figure 10-2/G.8121/Y.1381 – MT/ETH\_A\_So process diagram

add MI\_Active

– LCK Generate process:

See 8.1.2 of [ITU-T G.8021].

– Selector process:

See 8.1.3 of [ITU-T G.8021]. The normal CI is blocked if Admin\_State = LOCKED.

– OAM MEL Filter process:

See 8.1.1 of [ITU-T G.8021].

– 802.3 MAC FCS generation:

See 8.8.1 of [ITU-T G.8021]. MAC FCS generation is optional (see [IETF RFC 4720] and [ITU-T Y.1415]): MAC FCS is generated if MI\_FCSEnable is True.

– QoS mapping process:

This process maps the Ethernet-based QoS signals into MPLS-based QoS signals.



The CoS part of the AI\_PHB is generated by the received CI\_P according to the 1:1 mapping configured by the MI\_PRI2CoSMapping.

The DP part of the AI\_PHB is generated by the received CI\_DE according to the following rule:

```
If CI_DE = True
    DP(AI_PHB) = Yellow
Else
    DP(AI_PHB) = Green
```

– *CW Insertion process:*

See 8.5.1.

– *Insert S bit process:*

A 1-bit S Field set to 1 (bottom of label stack) is inserted to indicate the client is not MPLS.

• **Defects:**

*None.*

• **Consequent actions:**

*None.*

• **Defect correlations:**

*None.*

• **Performance monitoring:**

*None.*

### 10.1.2 MPLS-TP to ETH adaptation sink function (MT/ETH\_A\_Sk)

This function extracts the ETH\_CI information from an MT\_AI signal.

The information flow and processing of the MT/ETH\_A\_Sk function is defined with reference to Figure 10-3.

• **Symbol:**

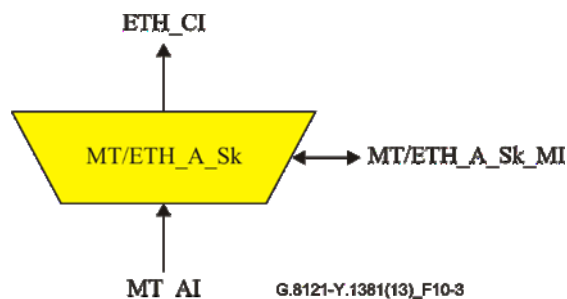


Figure 10-3/G.8121/Y.1381 – MT/ETH\_A\_Sk function

• **Interfaces:**

**Table 10-2/G.8121/Y.1381 – MT/ETH\_A\_Sk Inputs and Outputs**

Inputs	Outputs
<p><b>Each MT_AP:</b>            MT_AI_Data            MT_AI_PHB            MT_AI_TSF            MT_AI_AIS</p> <p><b>MT/ETH_A_Sk_MP:</b>            MT/ETH_A_Sk_MI_Active            MT/ETH_A_Sk_MI_FCSEnable            MT/ETH_A_Sk_MI_CWEnable            MT/ETH_A_Sk_MI_SQUse            MT/ETH_A_Sk_MI_GAL_Enable            MT/ETH_A_Sk_MI_CoS2PRIMapping</p> <p>MT/ETH_A_Sk_MI_MEL *</p> <p>MT/ETH_A_Sk_MI_Admin_State            MT/ETH_A_Sk_MI_LCK_Period *            MT/ETH_A_Sk_MI_LCK_Pri *            MT/ETH_A_Sk_MI_Client_MEL *            MT/ETH_A_Sk_MI_MEP_MAC *            MT/ETH_A_Sk_MI_AIS_Pri *            MT/ETH_A_Sk_MI_AIS_Period *</p> <p>* ETH OAM related</p>	<p><b>ETH_FP:</b>            ETH_CI_Data            ETH_CI_P            ETH_CI_DE            ETH_CI_SSF</p> <p><b>MT/ETH_A_Sk_MP:</b>            MT/ETH_MI_pFCSErrors</p>

**Processes:**

The processes associated with the MT/ETH\_A\_Sk function are as depicted in Figure 10-4

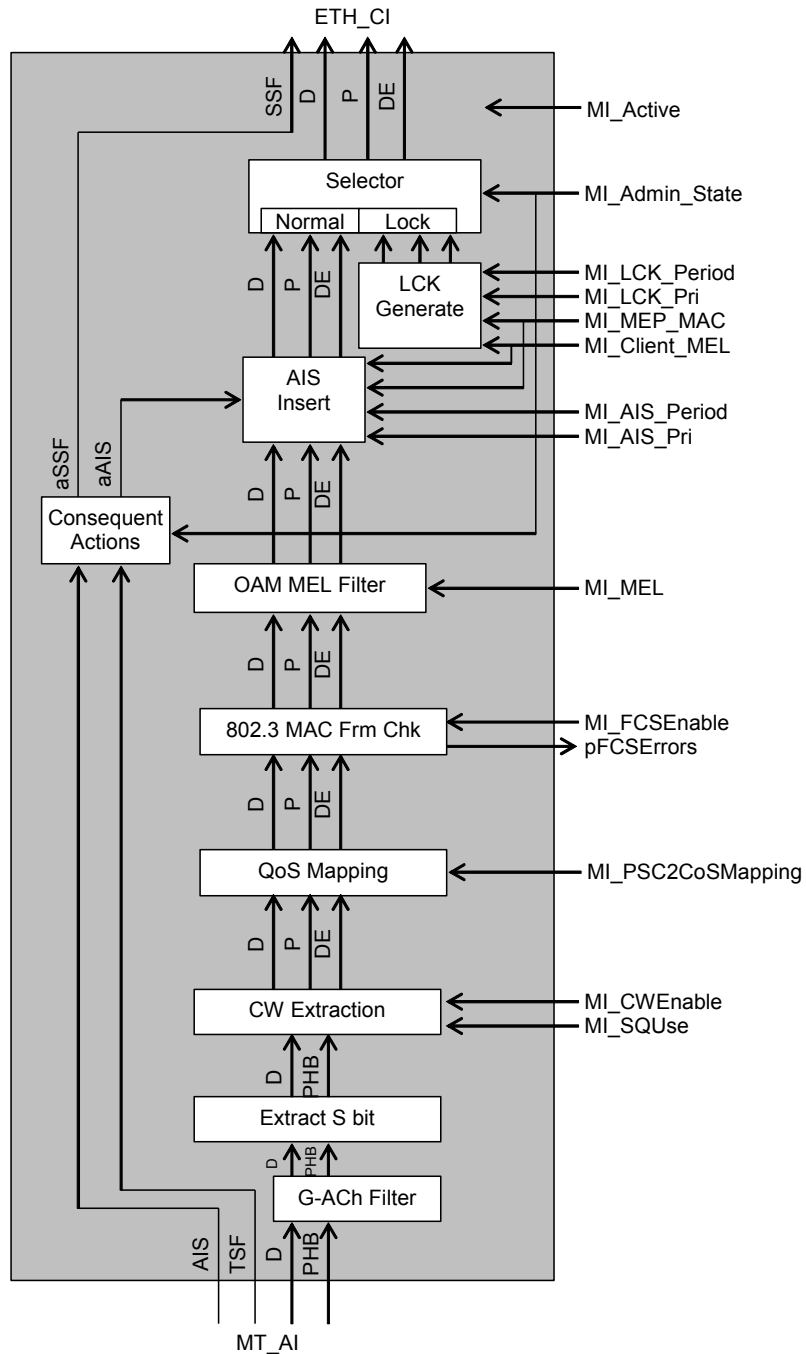


Figure 10-4/G.8121/Y.1381 – MT/ETH\_A\_Sk process diagram

[New figure: add MI\_Active]

– Selector process:

See 8.1.3 of [ITU-T G.8021]. The normal CI is blocked if Admin\_State = LOCKED.

– LCK Generate process:

See 8.1.2 of [ITU-T G.8021].

– *AIS Insert process:*

See 8.1.4 of [ITU-T G.8021].

– *OAM MEL Filter process:*

See 8.1.1 of [ITU-T G.8021].

– *"802.3 MAC Frame Check" process:*

See 8.9.2/G.8021/Y.1341. MAC Frame Check is optional (see [IETF RFC 4720] and [ITU-T Y.1415]): MAC FCS is checked if MI\_FCSEnabled is True.

– *QoS mapping process:*

This process maps the MPLS-based QoS signals into Ethernet-based QoS signals.

The CI\_P is generated by the received PSC part of the AI\_PHB according to the 1:1 mapping configured by the MI\_CoS2PRIMapping.

The CI\_DE is generated by the received DP part of the AI\_PHB according to the following rule

```
If DP(AI_PHB) = Green
    CI_DE = False
Else
    CI_DE = True
```

– *CW Extraction process:*

See 8.5.2.

– *G-ACh Filter process:*

This process removes all the received traffic units which are G-ACh encapsulated, which include GAL or not depending on the MI\_GAL\_Enable.

– *Extract S bit process:*

Extract and process the 1-bit S Field: the retrieved S Field should have the value 1 (bottom of label stack) to indicate the client is not MPLS: for such case the traffic unit is accepted and forwarded (together with the PHB information) after extraction of the S-bit field to the next process. For the case the S-bit has the value 0, the traffic unit is silently discarded.

• **Defects:**

*None.*

• **Consequent actions:**

The function shall perform the following consequent actions:

aSSF ← AI\_TSF and (not MI\_Admin\_State == LOCKED)

aAIS ← AI\_AIS • **Defect correlations:**

*None.*

• **Performance monitoring:**

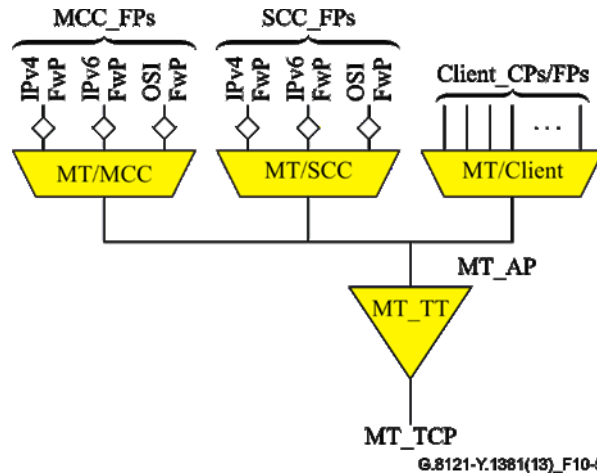
*For further study.*

## 10.2 MPLS-TP to SCC and MCC Adaptation functions

This clause provides the descriptions of the MPLS-TP adaptation functions for the MPLS-TP MCC and SCC.

Figure 10-5 shows the MPLS-TP adaptation functions providing access to the MCC and SCC. These MT/MCC and MT/SCC adaptation functions are defined in more detail below.

In case that the client is MPLS-TP, MT/Client will be MT/MT,



**Figure 10-5/G.8121/Y.1382 – MT/SCC\_A function, MT/MCC\_A function, and MT/client\_A function**

### 10.2.1 MT/SCC\_A Adaptation Function

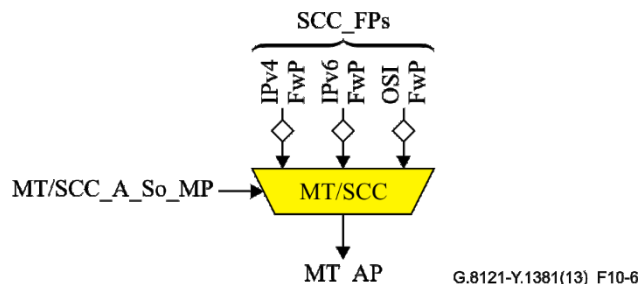
The MT to SCC adaptation function provides access to the SCC for signalling communication. It is used for the scenarios where the SCN utilizes the SCC as defined in [IETF RFC5718].

#### 10.2.1.1 MT to SCC adaptation source function (MT/SCC\_A\_So function)

The MT/SCC\_A\_So function maps the SCN data into the G-ACh SCC packets as defined in [IETF RFC5718]. The diamonds in Figure 10-6 represent traffic shaping and conditioning functions that may be needed to prevent the SCC forwarding points from exceeding their committed bandwidth in congestion situations. These traffic shaping and conditioning functions as well as the related bandwidth management and bandwidth assignment functions are outside the scope of this recommendation.

The information flow and processing of the MT/SCC\_A\_So functions is defined with reference to Figures 10-6 and 10-7.

#### Symbol



**Figure 10-6/G.8121/Y.1382 – MT/SCC\_A\_So function**

**Interfaces**

**Table 10-3/G.8121/Y.1382 – MT/SCC\_A\_So inputs and outputs**

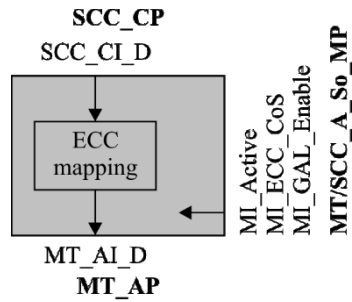
Input(s)	Output(s)
<b>SCC_FP:</b> SCC_CI_D <b>MT/SCC_A_So_MP:</b> MT/SCC_A_So_MI_Active MT/SCC_A_So_MI_ECC_CoS MT/SCC_A_So_MI_GAL_Enable	<b>MT_AP:</b> MT_AI_D MT_AI_PHB

**Processes**

*Activation*

– The MT/SCC\_A\_So function shall access the access point when it is activated (MI\_Active is true). Otherwise, it shall not access the access point.

The process associated with the MT/SCC\_A\_So function is as depicted in Figure 10-7.



G.8121-Y.1381(13)\_F10-7

**Figure 10-7/G.8121/Y.1382 – MT/SCC\_A\_So processes**

**ECC Mapping process:** See clause 8.7.1.1

**Defects:** None.

**Consequent actions:** None.

**Defect correlations:** None.

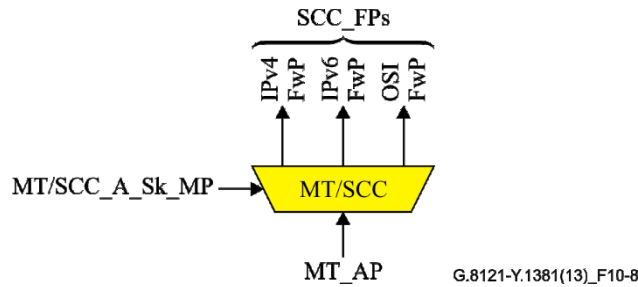
**Performance Monitoring:** None.

**10.2.1.2 MT to SCC adaptation sink function (MT/SCC\_A\_Sk function)**

The MT/SCC\_A\_Sk function extracts the SCN from the G-ACh SCC packets as defined in [IETF RFC5718].

The information flow and processing of the MT/SCC\_A\_Sk functions is defined with reference to Figures 10-8 and 10-9.

**Symbol**



**Figure 10-8/G.8121/Y.1382 – MT/SCC\_A\_Sk function**

**Interfaces**

**Table 10-4/G.8121/Y.1382 – MT/SCC\_A\_Sk inputs and outputs**

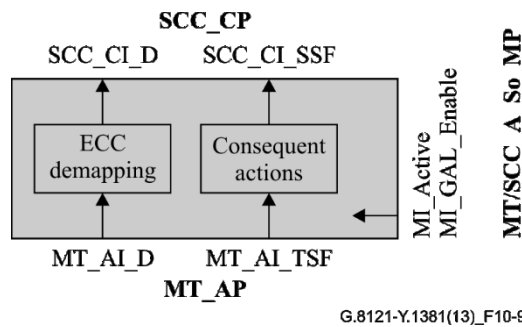
Input(s)	Output(s)
<b>MT_AP:</b> MT_AI_D MT_AI_PHB MT_AI_TSF <b>MT/SCC_A_Sk_MP:</b> MT/SCC_A_Sk_MI_Active MT/SCC_A_Sk_MI_GAL_Enable	<b>SCC_FP:</b> SCC_CI_D SCC_CI_SSF

**Processes**

*Activation*

– The MT/SCC\_A\_Sk function shall access the access point and perform the common and specific processes operation specified below when it is activated (MI\_Active is true). Otherwise, it shall activate the SSF signals at its output (CI\_SSF).

The processes associated with the MT/SCC\_A\_Sk function are as depicted in Figure 10-9.



**Figure 10-9/G.8121/Y.1382 – MT/SCC\_A\_Sk processes**

**ECC Demapping process:** See clause 8.7.1.2

**Defects:** None.

**Consequent actions**

The function shall perform the following consequent actions:

aSSF ← AI\_TSF or (not MI\_Active)

**Defect correlations:** None.

**Performance monitoring:** None.

### 10.2.2 MT/MCC\_A Adaptation Function

The MT to MCC adaptation function provides access to the MCC for signalling communication. It is used for the scenarios where the MCN utilizes the MCC as defined in [IETF RFC5718].

#### 10.2.2.1 MT to MCC adaptation source function (MT/MCC\_A\_So function)

The MT/MCC\_A\_So function maps the MCN data into the G-ACh MCC packets as defined in [IETF RFC5718]. The diamonds in Figure 10-10 represent traffic shaping and conditioning functions that may be needed to prevent the MCC forwarding points from exceeding their committed bandwidth in congestion situations. These traffic shaping and conditioning functions as well as the related bandwidth management and bandwidth assignment functions are outside the scope of this recommendation.

The information flow and processing of the MT/MCC\_A\_So functions is defined with reference to Figures 10-10 and 10-11.

#### Symbol

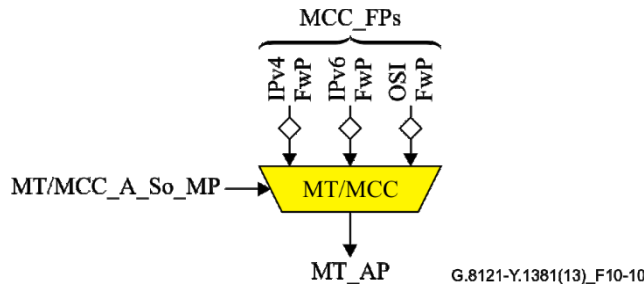


Figure 10-10/G.8121/Y.1382 – MT/MCC\_A\_So function

#### Interfaces

Table 10-5/G.8121/Y.1382 – MT/MCC\_A\_So inputs and outputs

Input(s)	Output(s)
<b>MCC_FP:</b> MCC_CI_D <b>MT/MCC_A_So_MP:</b> MT/MCC_A_So_MI_Active MT/MCC_A_So_MI_ECC_CoS MT/MCC_A_So_MI_GAL_enable	<b>MT_AP:</b> MT_AI_D MT_AI_PHB

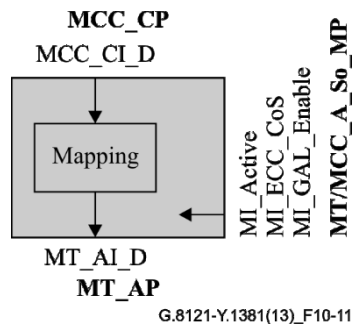
#### Processes

##### Activation

- The MT/MCC\_A\_So function shall access the access point when it is activated (MI\_Active is true). Otherwise, it shall not access the access point.



The process associated with the MT/MCC\_A\_So function is as depicted in Figure 10-11.



**Figure 10-11/G.8121/Y.1382 – MT/MCC\_A\_So processes**

**MCC Mapping process:** See clause 8.7.1.1

**Defects:** None.

**Consequent actions:** None.

**Defect correlations:** None.

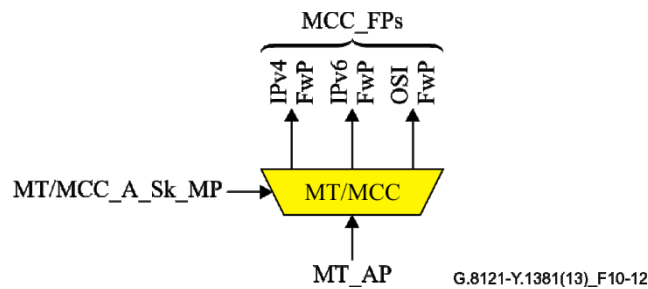
**Performance Monitoring:** None.

### 10.2.2.2 MT to MCC adaptation source function (MT/SCC\_A\_Sk function)

The MT/MCC\_A\_Sk function extracts the MCN data from the G-ACh MCC packets as defined in [IETF RFC5718].

The information flow and processing of the MT/MCC\_A\_Sk functions is defined with reference to Figures 10-12 and 10-13.

#### Symbol



**Figure 10-12/G.8121/Y.1382 – MT/MCC\_A\_Sk function**

**Interfaces**

**Table 10-6/G.8121/Y.1382 – MT/MCC\_A\_Sk inputs and outputs**

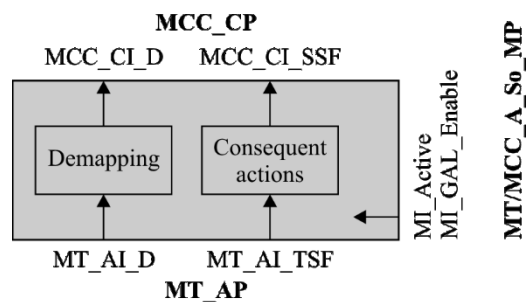
Input(s)	Output(s)
<b>MT_AP:</b> MT_AI_D MT_AI_PHB MT_AI_TSF  <b>MT/MCC_A_Sk_MP:</b> MT/MCC_A_Sk_MI_Active MT/SCC_A_Sk_MI_GAL_Enable	<b>MCC_FP:</b> MCC_CI_D MCC_CI_SSF

**Processes**

*Activation*

– The MT/MCC\_A\_Sk function shall access the access point and perform the common and specific processes operation specified below when it is activated (MI\_Active is true). Otherwise, it shall activate the SSF signals at its output (CI\_SSF).

The processes associated with the MT/MCC\_A\_Sk function are as depicted in Figure 10-13.



G.8121-Y.1381(13)\_F10-13

**Figure 10-13/G.8121/Y.1382 – MT/MCC\_A\_Sk processes**

**ECC Demapping process:** See clause 8.7.1.2

**Defects:** None.

**Consequent actions**

The function shall perform the following consequent actions:

aSSF ← AI\_TSF or (not MI\_Active)

**Defect correlations:** None.

**Performance monitoring:** None.

## 11 Non-MPLS-TP Server to MPLS-TP adaptation functions

### 11.1 SDH to MPLS-TP adaptation function (S/MT\_A)

#### 11.1.1 VC-n to MPLS-TP adaptation functions (Sn/MT\_A; n=3, 3-X, 4, 4-X)

##### 11.1.1.1 VC-n to MPLS-TP adaptation source function (Sn/MT\_A\_So)

This function maps MT\_CI information onto an Sn\_AI signal (n=3, 3-X, 4, 4-X).

Data at the Sn\_AP is a VC-n (n = 3, 3-X, 4, 4-X), having a payload as described in [ITU-T G.707], but with indeterminate POH bytes: J1, B3, G1.

• **Symbol:**

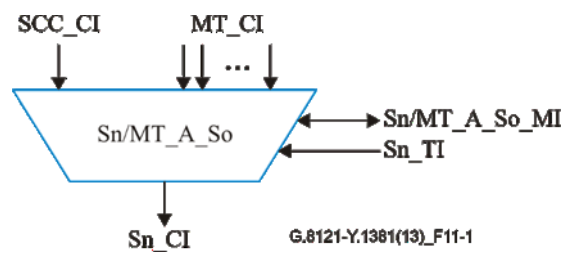


Figure 11-1/G.8121/Y.1381 – Sn/MT\_A\_So symbol

• **Interfaces:**

Table 11-1/G.8121/Y.1381 – Sn/MT\_A\_So interfaces

Inputs	Outputs
<p><b>Each MT_CP:</b>                      MT_CI_Data                      MT_CI_iPHB                      MT_CI_oPHB</p> <p><b>SCC_CP:</b>                      SCC_CI_Data</p> <p><b>Sn_TP:</b>                      Sn_TI_Clock                      Sn_TI_FrameStart</p> <p><b>Sn/MT_A_So_MP:</b>                      Sn/MT_A_So_MI_Active                      Sn/MT_A_So_MI_SCCType                      Sn/MT_A_So_MI_Label[1...M]                      Sn/MT_A_So_MI_LSPTType[1...M]                      Sn/MT_A_So_MI_CoS[1...M]                      Sn/MT_A_So_PHB2TCMapping[1...M]                      Sn/MT_A_So_MI_QoSEncodingMode[1...M]                      Sn/MT_A_So_MI_Mode[1...M]</p> <p>Sn/MT_A_So_MI_GAL_Enable[1...M]</p>	<p><b>Sn_AP:</b>                      Sn_AI_Data                      Sn_AI_Clock                      Sn_AI_FrameStart</p>

• **Processes:**

A process diagram of this function is shown in Figure 11-2.

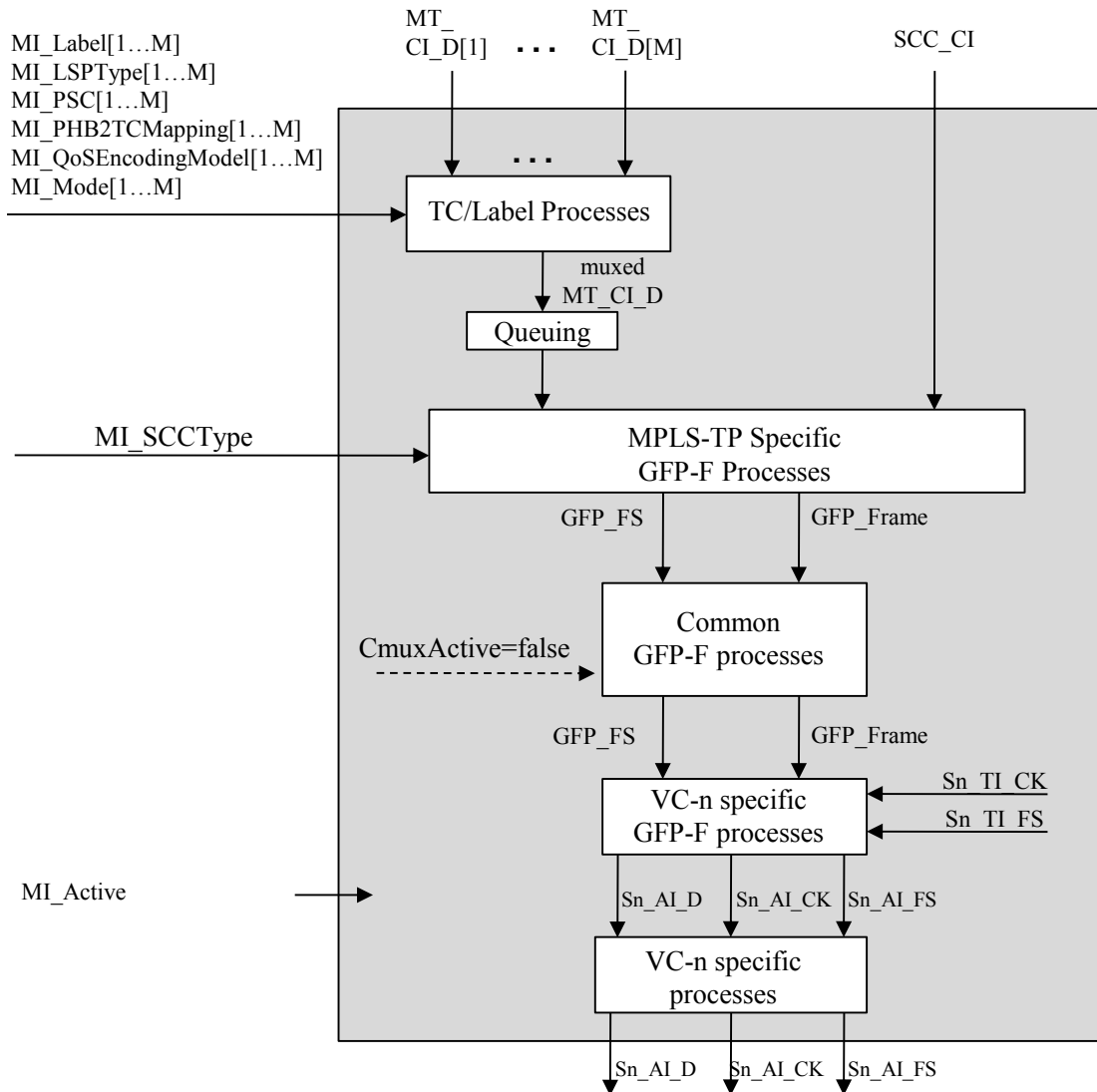


Figure 11-2/G.8121/Y.1381 – Sn/MT\_A\_So process diagram

[add MI active]

– *TC/Label processes:*

See 8.2.1.

– *Queuing process:*

See 8.3.

– *MPLS-TP-specific GFP-F source process:*

See 8.4.1.

– *Common GFP source process:*

See 8.5.3.1/G.806. GFP channel multiplexing is not supported (CMuxActive=false).

– *VC-n specific GFP source process:*

See 8.5.2.1/G.806. The GFP frames are mapped into the VC-n payload area according to 10.6/G.707/Y.1322.

– *VC-n specific source process:*

**C2:** Signal label information is derived directly from the Adaptation function type. The value for "GFP mapping" in Table 9-11/G.707/Y.1322 is placed in the C2 byte position.

**H4:** For Sn/MT\_A\_So with n=3, 4, the H4 byte is sourced as all-zeros.

NOTE 1 – For Sn/MT\_A\_So with n=3-X, 4-X, the H4 byte is undefined at the Sn-X\_AP output of this function (as per clause 12/G.783).

NOTE 2 – For Sn/MT\_A\_So with n=3, 4, 3-X, 4-X, the K3, F2, F3 bytes are undefined at the Sn-X\_AP output of this function (as per clause 12/G.783).

• **Defects:**

*None.*

• **Consequent actions:**

*None.*

• **Defect correlations:**

*None.*

• **Performance monitoring:**

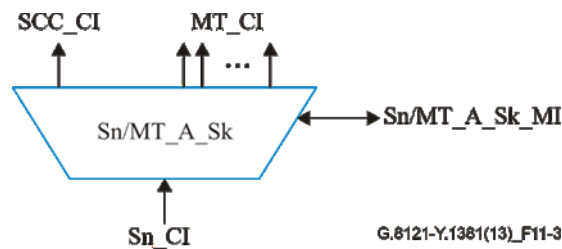
*For further study.*

**11.1.1.2 VC-n to MPLS-TP adaptation sink function (Sn/MT\_A\_Sk)**

This function extracts MT\_CI information from the Sn\_AI signal (n=3, 3-X, 4, 4-X), delivering MT\_CI.

Data at the Sn\_AP is a VC-n (n=3, 3-X, 4, 4-X) but with indeterminate POH bytes J1, B3, G1, as per [ITU-T G.707].

• **Symbol:**



**Figure 11-3/G.8121/Y.1381 – Sn/MT\_A\_Sk symbol**

• **Interfaces:**

**Table 11-2/G.8121/Y.1381 – Sn/MT\_A\_Sk interfaces**

Inputs	Outputs
<p><b>Sn_AP:</b>  Sn_AI_Data  Sn_AI_ClocK  Sn_AI_FrameStart  Sn_AI_TSF</p> <p><b>Sn/MT_A_Sk_MP:</b>  Sn/MT_A_Sk_MI_Active  Sn/MT_A_Sk_MI_SCCType  Sn/MT_A_Sk_MI_Label[1...M]  Sn/MT_A_Sk_MI_LSPTType[1...M]  Sn/MT_A_Sk_MI_CoS[1...M]  Sn/MT_A_Sk_MI_TC2PHBMapping[1...M]  Sn/MT_A_Sk_MI_QoSDecodingMode[1...M]  Sn/MT_A_Sk_MI_Mode[1...M]</p> <p>Sn/MT_A_Sk_MI_LCK_Period[1...M]  Sn/MT_A_Sk_MI_LCK_CoS[1...M]  Sn/MT_A_Sk_MI_Admin_State  Sn/MT_A_Sk_MI_AIS_Period[1...M]  Sn/MT_A_Sk_MI_AIS_CoS[1...M]  Sn/MT_A_Sk_MI_GAL_enable[1...M]  Sn/MT_A_Sk_MI_LCK_OAM_Tool [1...M]  Sn/MT_A_Sk_MI_AIS_OAM_Tool[1...M]</p>	<p><b>Each MT_CP:</b>  MT_CI_Data  MT_CI_iPHB  MT_CI_oPHB  MT_CI_SSF  MT_CI_LStack</p> <p><b>SCC_CP:</b>  SCC_CI_Data  SCC_CI_SSF</p> <p><b>Sn/MT_A_Sk_MP:</b>  Sn/MT_A_Sk_MI_AcSL  Sn/MT_A_Sk_MI_AcEXI  Sn/MT_A_Sk_MI_LastInvalidUPI  Sn/MT_A_Sk_MI_cPLM  Sn/MT_A_Sk_MI_cLFD  Sn/MT_A_Sk_MI_cEXM  Sn/MT_A_Sk_MI_cUPM</p>

• **Processes:**

A process diagram of this function is shown in Figure 11-4.



– *Common GFP sink process:*

See 8.5.3.2 in [ITU-T G.806]. GFP channel multiplexing is not supported (CMuxActive=false).

– *VC-n specific GFP sink process:*

See 8.5.2.2 in [ITU-T G.806]. The GFP frames are demapped from the VC-n payload area according to 10.6 in [ITU-T G.707].

– *VC-n-specific sink process:*

**C2:** The signal label is recovered from the C2 byte as per 6.2.4.2 in [ITU-T G.806]. The signal label for "GFP mapping" in Table 9-11 of [ITU-T G.707] shall be expected. The accepted value of the signal label is also available at the Sn/MT\_A\_Sk\_MP.

• **Defects:**

dPLM – See 6.2.4.2 in [ITU-T G.806].

dLFD – See 6.2.5.2 in [ITU-T G.806].

dEXM – See 6.2.4.4 in [ITU-T G.806].

dUPM – See 8.4.2.

• **Consequent actions:**

The function shall perform the following consequent actions:

aSSF ← AI\_TSF or dPLM or dLFD or dUPM or dEXM

aAIS ← AI\_TSF or dPLM or dLFD or dUPM or dEXM

• **Defect correlations:**

The function shall perform the following defect correlations to determine the most probable fault cause (see 6.4/G.806). This fault cause shall be reported to the EMF.

cPLM ← dPLM and (not AI\_TSF)

cLFD ← dLFD and (not dPLM) and (not AI\_TSF)

cEXM ← dEXM and (not dPLM) and (not dLFD) and (not AI\_TSF)

cUPM ← dUPM and (not dEXM) and (not dPLM) and (not dLFD) and (not AI\_TSF)

• **Performance monitoring:**

*For further study.*

## **11.1.2 LCAS-capable VC-n to MPLS-TP adaptation functions (Sn-X-L/MT\_A; n=3, 4)**

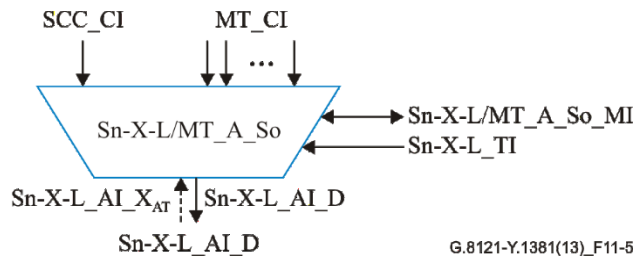
### **11.1.2.1 LCAS-capable VC-n to MPLS-TP adaptation source function (Sn-X-L/MT\_A\_So)**

This function maps MT\_CI information onto an Sn-X-L\_AI signal (n=3, 4).

Data at the Sn-X-L\_AP is a VC-n-X (n = 3, 4), having a payload as described in [ITU-T G.707], but with indeterminate POH bytes: J1, B3, G1.



• **Symbol:**



**Figure 11-5/G.8121/Y.1381 – Sn-X-L/MT\_A\_So symbol**

• **Interfaces:**

**Table 11-3/G.8121/Y.1381 – Sn-X-L/MT\_A\_So interfaces**

Inputs	Outputs
<p><b>Each MT_CP:</b>                      MT_CI_Data                      MT_CI_iPHB                      MT_CI_oPHB</p> <p><b>SCC_CP:</b>                      SCC_CI_Data</p> <p><b>Sn-X-L_AP:</b>                      Sn-X-L_AI_X_AT</p> <p><b>Sn-X-L_TP:</b>                      Sn-X-L_TI_Clock                      Sn-X-L_TI_FrameStart</p> <p><b>Sn-X-L/MT_A_So_MP:</b>                      Sn-X-L/MT_A_So_MI_Active                      Sn-X-L/MT_A_So_MI_SCCType                      Sn-X-L/MT_A_So_MI_Label[1...M]                      Sn-X-L/MT_A_So_MI_LSPTType[1...M]                      Sn-X-L/MT_A_So_MI_CoS[1...M]                      Sn-X-L/MT_A_So_PHB2TCMapping[1...M]                      Sn-X-L/MT_A_So_MI_QoSEncodingMode[1...M]                      Sn-X-L/MT_A_So_MI_Mode[1...M]</p> <p>Sn-X-L/MT_A_So_MI_GAL_Enable[1...M]                      ]</p>	<p><b>Sn-X-L_AP:</b>                      Sn-X-L_AI_Data                      Sn-X-L_AI_Clock                      Sn-X-L_AI_FrameStart</p>

• **Processes:**

A process diagram of this function is shown in Figure 11-6.

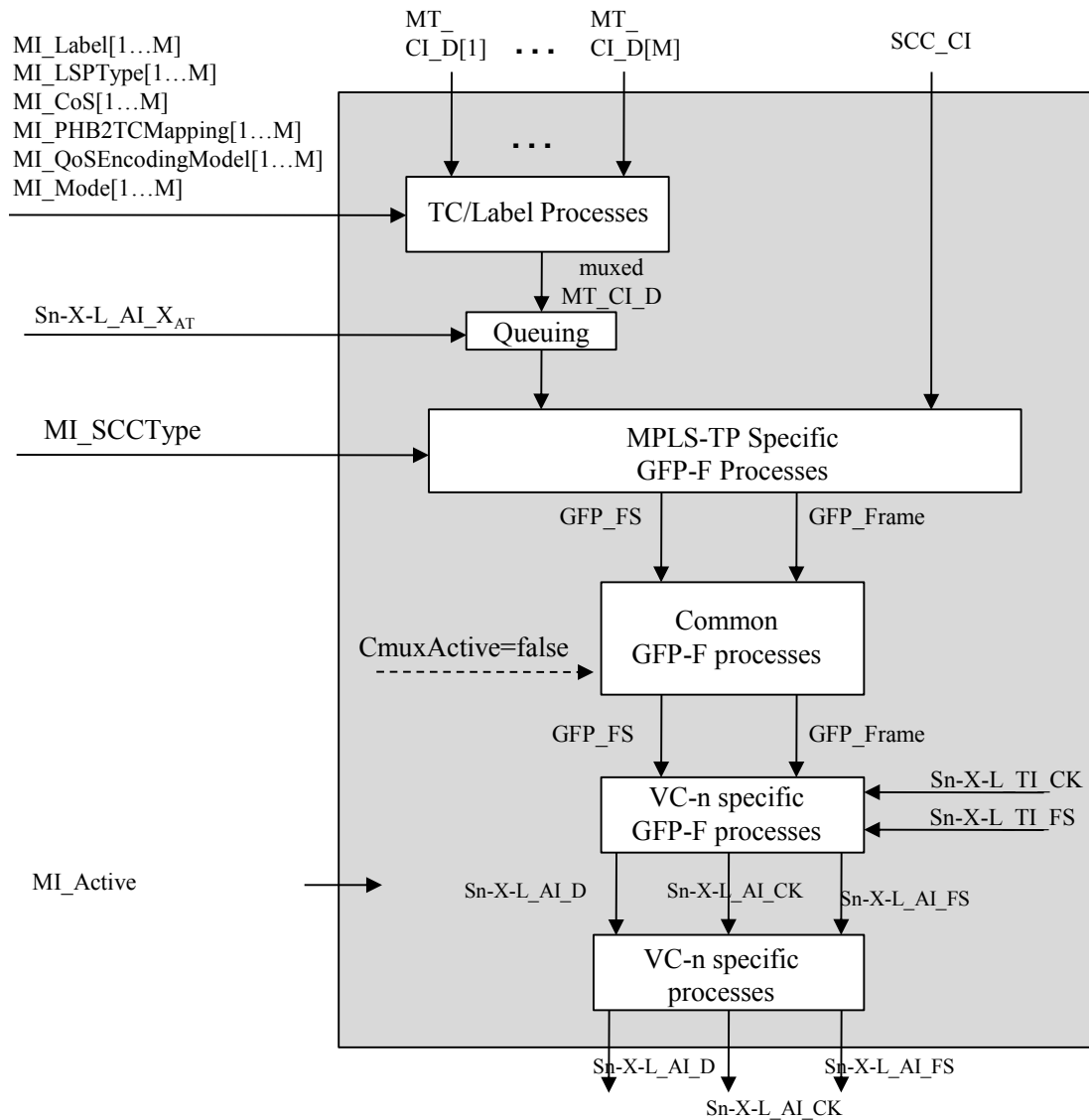


Figure 11-6/G.8121/Y.1381 – Sn-X-L/MT\_A\_So process diagram  
[add MI\_Active]

The processes have the same definition as in 11.1.1.1.

• **Defects:**

None.

• **Consequent actions:**

None.

• **Defect correlations:**

None.

• **Performance monitoring:**

For further study.

### 11.1.2.2 LCAS-capable VC-n to MPLS-TP adaptation sink function (Sn-X-L/MT\_A\_Sk)

This function extracts MT\_CI information from the Sn-X-L\_AI signal (n=3, 4), delivering MT\_CI. Data at the Sn-X-L\_AP is a VC-n-Xv (n=3, 4) but with indeterminate POH bytes J1, B3, G1, as per [ITU-T G.707].

• **Symbol:**

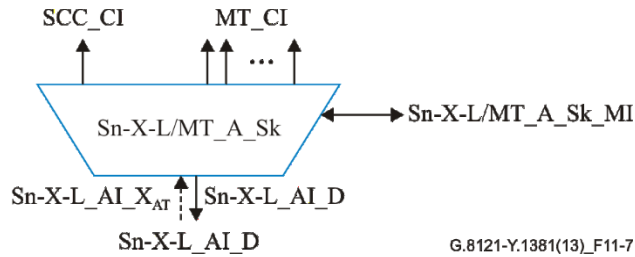


Figure 11-7/G.8121/Y.1381 – Sn-X-L/MT\_A\_Sk symbol

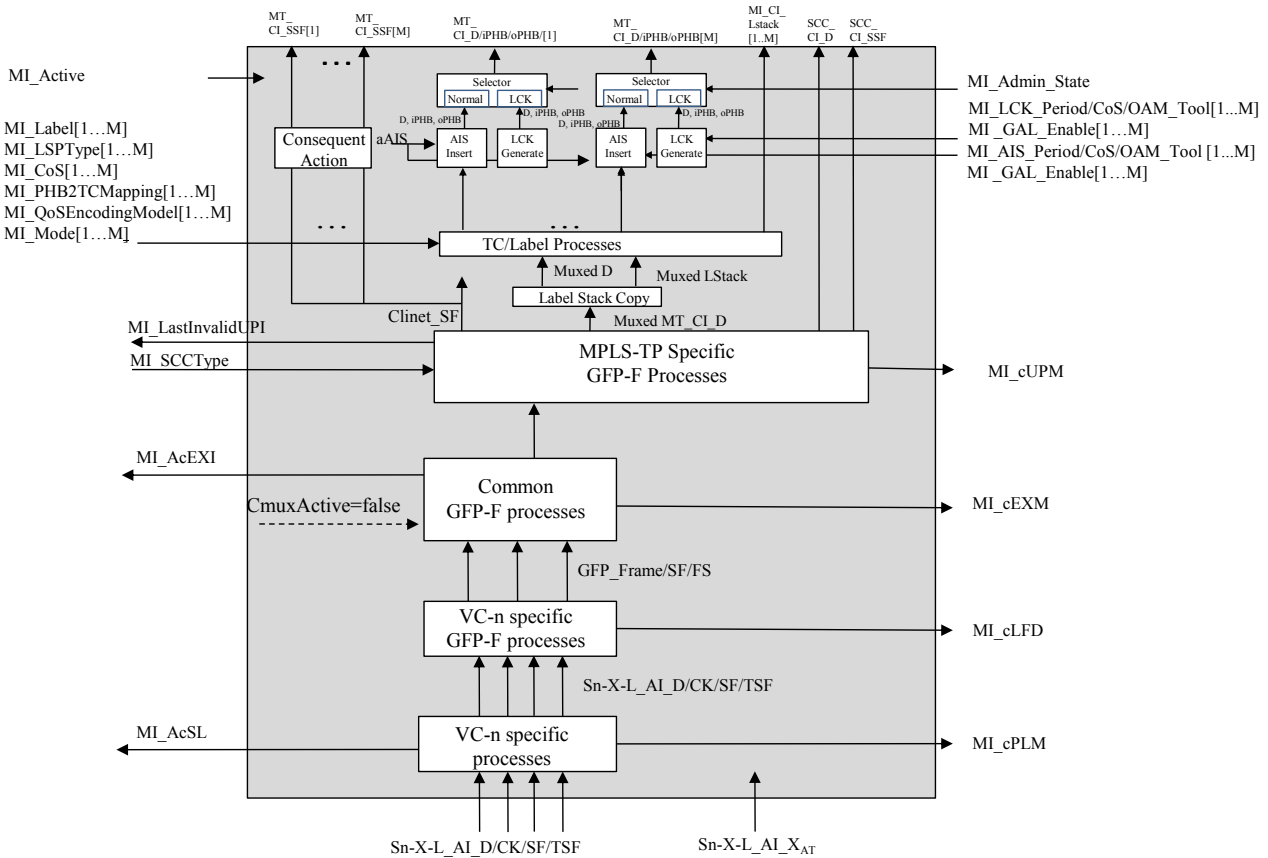
• **Interfaces:**

Table 11-4/G.8121/Y.1381 – Sn-X-L/MT\_A\_Sk interfaces

Inputs	Outputs
<p><b>Sn-X-L_AP:</b>  Sn-X-L_AI_Data  Sn-X-L_AI_Clock  Sn-X-L_AI_FrameStart  Sn-X-L_AI_TSF  Sn-X-L_AI_XAR</p> <p><b>Sn-X-L/MT_A_Sk_MP:</b>  Sn-X-L/MT_A_Sk_MI_Active  Sn-X-L/MT_A_Sk_MI_SCCType  Sn-X-L/MT_A_Sk_MI_Label[1...M]  Sn-X-L/MT_A_Sk_MI_LSPTType[1...M]  Sn-X-L/MT_A_Sk_MI_CoS[1...M]  Sn-X-L/MT_A_Sk_MI_TC2PHBMapping[1...M]  Sn-X-L/MT_A_Sk_MI_QoSDecodingMode[1...M]  Sn-X-L/MT_A_Sk_MI_Mode[1...M]</p> <p>Sn-X-L /MT_A_Sk_MI_LCK_Period[1...M]  Sn-X-L /MT_A_Sk_MI_LCK_CoS[1...M]  Sn-X-L /MT_A_Sk_MI_Admin_State  Sn-X-L /MT_A_Sk_MI_AIS_Period[1...M]  Sn-X-L /MT_A_Sk_MI_AIS_CoS [1...M]  Sn-X-L /MT_A_Sk_MI_GAL_Enable [1...M]  Sn-X-L /MT_A_Sk_MI_LCK_OAM_Tool [1...M]  Sn-X-L /MT_A_Sk_MI_AIS_OAM_Tool [1...M]</p>	<p><b>Each MT_CP:</b>  MT_CI_Data  MT_CI_iPHB  MT_CI_oPHB  MT_CI_SSF  MI_CI_LStack</p> <p><b>SCC_CP:</b>  SCC_CI_Data  SCC_CI_SSF</p> <p><b>Sn-X-L/MT_A_Sk_MP:</b>  Sn-X-L/MT_A_Sk_MI_AcSL  Sn-X-L/MT_A_Sk_MI_AcEXI  Sn-X-L/MT_A_Sk_MI_LastInvalidUPI  Sn-X-L/MT_A_Sk_MI_cPLM  Sn-X-L/MT_A_Sk_MI_cLFD  Sn-X-L/MT_A_Sk_MI_cEXM  Sn-X-L/MT_A_Sk_MI_cUPM</p>

• **Processes:**

A process diagram of this function is shown in Figure 11-8.



**Figure 11-8/G.8121/Y.1381 – Sn-X-L/MT\_A\_Sk process diagram**

[new: add MI\_Active Remove APS, GFP\_Length]

See process diagram and process description in 11.1.1.2. The additional Sn-X-L\_AI\_XAR interface is not connected to any of the internal processes.

• **Defects:**

dPLM – See 6.2.4.2 in [ITU-T G.806].

dLFD – See 6.2.5.2 in [ITU-T G.806].

dUPM – See 8.4.2.

dEXM – See 6.2.4.4 in [ITU-T G.806].

• **Consequent actions:**

The function shall perform the following consequent actions:

aSSF ← AI\_TSF or dPLM or dLFD or dUPM or dEXM

aAIS ← AI\_TSF or dPLM or dLFD or dUPM or dEXM

• **Defect correlations:**

The function shall perform the following defect correlations to determine the most probable fault cause (see 6.4 in [ITU-T G.806]). This fault cause shall be reported to the EMF.

cPLM ← dPLM and (not AI\_TSF)

cLFD ← dLFD and (not dPLM) and (not AI\_TSF)

cEXM ← dEXM and (not dPLM) and (not dLFD) and (not AI\_TSF)

cUPM ← dUPM and (not dEXM) and (not dPLM) and (not dLFD) and (not AI\_TSF)

• **Performance monitoring:**

*For further study.*

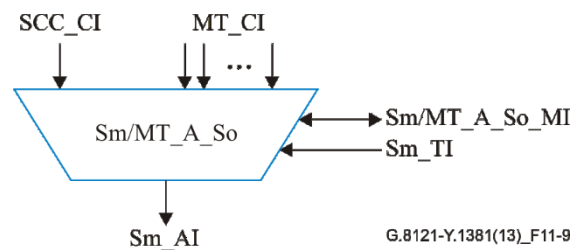
**11.1.3 VC-m to MPLS-TP adaptation functions (Sm/MT\_A; m=11, 11-X, 12, 12-X)**

**11.1.3.1 VC-m to MPLS-TP adaptation source function (Sm/MT\_A\_So)**

This function maps MT\_CI information onto an Sm\_AI signal (m=11, 11-X, 12, 12-X).

Data at the Sm\_AP is a VC-m (m = 11, 11-X, 12, 12-X), having a payload as described in [ITU-T G.707], but with indeterminate POH bytes: J2, V5[1-4], V5[8].

• **Symbol:**



**Figure 11-9/G.8121/Y.1381 – Sm/MT\_A\_So symbol**

• **Interfaces:**

**Table 11-5/G.8121/Y.1381 – Sm/MT\_A\_So interfaces**

Inputs	Outputs
<p><b>Each MT_CP:</b>            MT_CI_Data            MT_CI_iPHB            MT_CI_oPHB</p> <p><b>SCC_CP:</b>            SCC_CI_Data</p> <p><b>Sm_TP:</b>            Sm_TI_Clock            Sm_TI_FrameStart</p> <p><b>Sm/MT_A_So_MP:</b>            Sm/MT_A_So_MI_Active            Sm/MT_A_So_MI_SCCType            Sm/MT_A_So_MI_Label[1...M]            Sm/MT_A_So_MI_LSPTType[1...M]            Sm/MT_A_So_MI_CoS[1...M]            Sm/MT_A_So_PHB2TCMapping[1...M]            Sm/MT_A_So_MI_QoSEncodingMode[1...M]            Sm/MT_A_So_MI_Mode[1...M]</p> <p>Sm/MT_A_So_MI_GAL_Enable[1...M]</p>	<p><b>Sm_AP:</b>            Sm_AI_Data            Sm_AI_Clock            Sm_AI_FrameStart</p>

• **Processes:**

A process diagram of this function is shown in Figure 11-10.

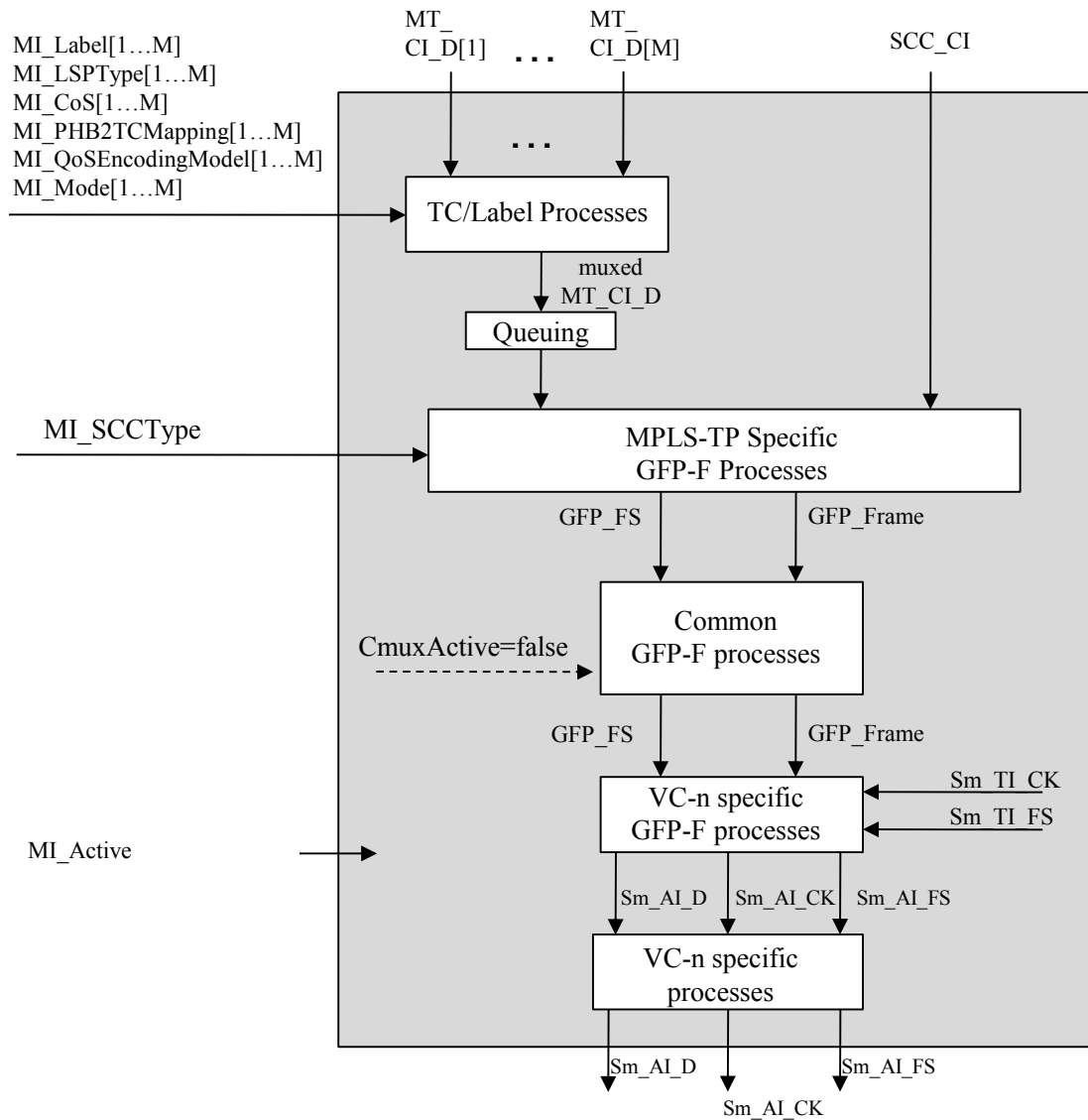


Figure 11-10/G.8121/Y.1381 – Sm/MT\_A\_So process diagram

[add MI\_Active]

– TC/Label processes:

See 8.2.1.

– Queuing process:

See 8.3.

– MPLS-TP-specific GFP-F source process:

See 8.4.1.

– Common GFP source process:

See 8.5.3.1/G.806. GFP channel multiplexing is not supported (CMuxActive=false).

– *VC-m-specific GFP source process:*

See 8.5.2.1/G.806. The GFP frames are mapped into the VC-m payload area according to 10.6/G.707/Y.1322.

– *VC-m-specific source process:*

**V5[5-7] and K4[1]:** Signal label information is derived directly from the Adaptation function type. The value for "GFP mapping" in Table 9-13/G.707/Y.1322 is placed in the K4[1] Extended Signal Label field as described in 8.2.3.2/G.783.

**K4[2]:** For Sm/MT\_A\_So with m = 11, 12, the K4[2] bit is sourced as all-zeros.

NOTE 1 – For Sm/MT\_A\_So with m = 11-X, 12-X, the K4[2] bit is undefined at the Sm-X\_AP output of this function (as per clause 13/G.783).

NOTE 2 – For Sm/MT\_A\_So with m = 11, 11-X, 12, 12-X, 2, the K4[3-8], V5[1-4] and V5[8] bits are undefined at the Sm-X\_AP output of this function (as per clause 13/G.783).

• **Defects:**

*None.*

• **Consequent actions:**

*None.*

• **Defect correlations:**

*None.*

• **Performance monitoring:**

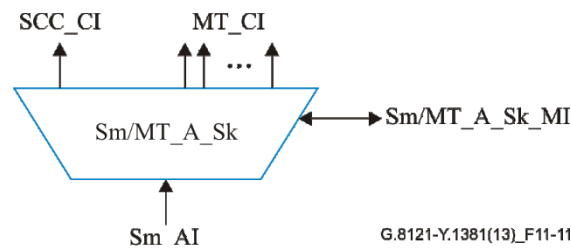
*For further study.*

**11.1.3.2 VC-m to MPLS-TP adaptation sink function (Sm/MT\_A\_Sk)**

This function extracts MT\_CI information from the Sm\_AI signal (m=11, 11-X, 12, 12-X), delivering MT\_CI.

Data at the Sm\_AP is a VC-m (m=11, 11-X, 12, 12-X) but with indeterminate POH bytes J2, V5[1-4], V5[8], as per [ITU-T G.707].

• **Symbol:**



**Figure 11-11/G.8121/Y.1381 – Sm/MT\_A\_Sk symbol**



• **Interfaces:**

**Table 11-6/G.8121/Y.1381 – Sm/MT\_A\_Sk interfaces**

Inputs	Outputs
<p><b>Sm_AP:</b> Sm_AI_Data Sm_AI_Clock Sm_AI_FrameStart Sm_AI_TSF</p> <p><b>Sm/MT_A_Sk_MP:</b> Sm/MT_A_Sk_MI_Active Sm/MT_A_Sk_MI_SCCType Sm/MT_A_Sk_MI_Label[1...M] Sm/MT_A_Sk_MI_LSPTType[1...M] Sm/MT_A_Sk_MI_CoS[1...M] Sm/MT_A_Sk_MI_TC2PHBMapping[1...M] Sm/MT_A_Sk_MI_QoSDecodingMode[1...M] Sm/MT_A_Sk_MI_Mode[1...M]</p> <p>Sm/MT_A_Sk_MI_LCK_Period[1...M] Sm/MT_A_Sk_MI_LCK_CoS[1...M] Sm/MT_A_Sk_MI_Admin_State Sm/MT_A_Sk_MI_AIS_Period[1...M] Sm/MT_A_Sk_MI_AIS_CoS[1...M] Sm/MT_A_Sk_MI_GAL_Enable[1...M] Sm/MT_A_Sk_MI_LCK_OAM_Tool [1...M] Sm/MT_A_Sk_MI_AIS_OAM_Tool[1...M]</p>	<p><b>Each MT_CP:</b> MT_CI_Data MT_CI_iPHB MT_CI_oPHB MT_CI_SSF MI_CI_LStack</p> <p><b>SCC_CP:</b> SCC_CI_Data SCC_CI_SSF</p> <p><b>Sm/MT_A_Sk_MP:</b> Sm/MT_A_Sk_MI_AcSL Sm/MT_A_Sk_MI_AcEXI Sm/MT_A_Sk_MI_LastInvalidUPI Sm/MT_A_Sk_MI_cPLM Sm/MT_A_Sk_MI_cLFD Sm/MT_A_Sk_MI_cEXM Sm/MT_A_Sk_MI_cUPM</p>

• **Processes:**

A process diagram of this function is shown in Figure 11-12

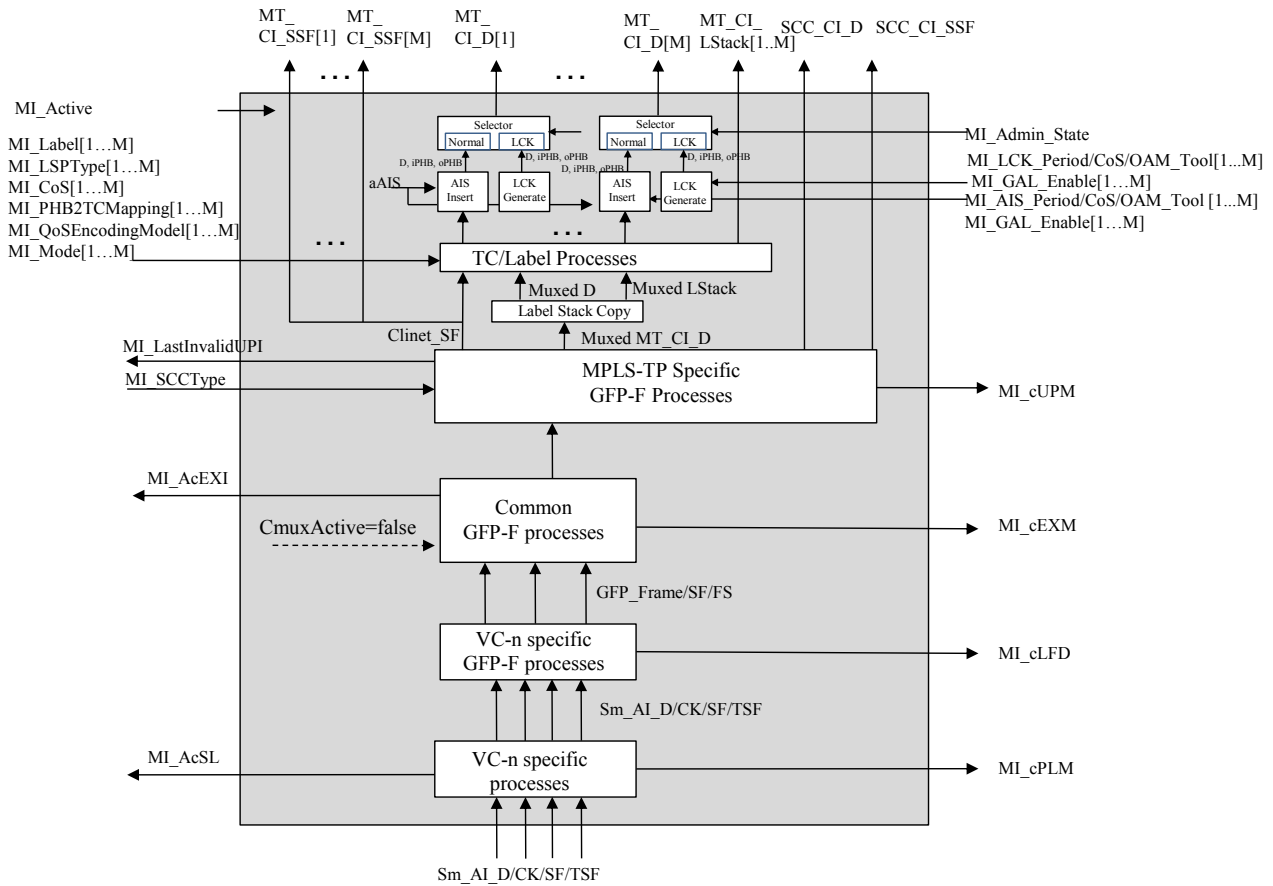


Figure 11-12/G.8121/Y.1381 – Sm/MT\_A\_Sk process diagram

[new: add MI\_Active Remove APS, GFP\_Length]

– Selector generation process:

See 8.6.1 The normal CI is blocked if Admin\_State = LOCKED.

– AIS Insert process:

See 8.6.2. There is a single AIS Insert process for each MT.

– LCK generation process:

See 8.6.3. There is a single LCK Insert process for each MT.

– TC/Label processes:

See 8.2.2.

– Label Stack Copy process:

See 8.2.3.

– MPLS-TP specific GFP-F sink process:

See 8.4.2.

– *Common GFP sink process:*

See 8.5.3.2 in [ITU-T G.806]. GFP channel multiplexing is not supported (CMuxActive=false).

– *VC-m-specific GFP sink process:*

See 8.5.2.2 in [ITU-T G.806]. The GFP frames are demapped from the VC-m payload area according to 10.6 in [ITU-T G.707].

– *VC-m-specific sink process:*

**V5[5-7] and K4[1]:** The signal label is recovered from the extended signal label position as described in 8.2.3.2 in [ITU-T G.783] and 6.2.4.2 in [ITU-T G.806]. The signal label for "GFP mapping" in Table 9-13 in [ITU-T G.707] shall be expected. The accepted value of the signal label is also available at the Sm/MT\_A\_Sk\_MP.

• **Defects:**

dPLM – See 6.2.4.2 in [ITU-T G.806].

dLFD – See 6.2.5.2 in [ITU-T G.806].

dUPM – See 8.4.2.

dEXM – See 6.2.4.4 in [ITU-T G.806].

• **Consequent actions:**

The function shall perform the following consequent actions:

aSSF ← AI\_TSF or dPLM or dLFD or dUPM or dEXM

aAIS ← AI\_TSF or dPLM or dLFD or dUPM or dEXM

• **Defect correlations:**

The function shall perform the following defect correlations to determine the most probable fault cause (see 6.4/G.806). This fault cause shall be reported to the EMF.

cPLM ← dPLM and (not AI\_TSF)

cLFD ← dLFD and (not dPLM) and (not AI\_TSF)

cEXM ← dEXM and (not dPLM) and (not dLFD) and (not AI\_TSF)

cUPM ← dUPM and (not dEXM) and (not dPLM) and (not dLFD) and (not AI\_TSF)

• **Performance monitoring:**

*For further study.*

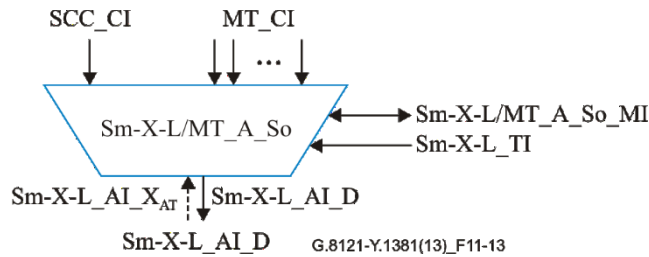
### 11.1.4 LCAS-capable VC-m to MPLS-TP adaptation functions (Sm-X-L/MT\_A; m=11, 12)

#### 11.1.4.1 LCAS-capable VC-m to MPLS-TP Adaptation Source function (Sm-X-L/MT\_A\_So)

This function maps MT\_CI information onto an Sm-X-L\_AI signal (m=11, 12).

Data at the Sm-X-L\_AP is a VC-m-X (m = 11, 12), having a payload as described in [ITU-T G.707], but with indeterminate POH bytes: J2, V5[1-4], V5[8].

• **Symbol:**



**Figure 11-13/G.8121/Y.1381 – Sm-X-L/MT\_A\_So symbol**

• **Interfaces:**

**Table 11-7/G.8121/Y.1381 – Sm-X-L/MT\_A\_So interfaces**

Inputs	Outputs
<p><b>Each MT_CP:</b>            MT_CI_Data            MT_CI_iPHB            MT_CI_oPHB</p> <p><b>SCC_CP:</b>            SCC_CI_Data</p> <p><b>Sm-X-L_AP:</b>            Sm-X-L_AI_X_AT</p> <p><b>Sm-X-L_TP:</b>            Sm-X-L_TI_Clock            Sm-X-L_TI_FrameStart</p> <p><b>Sm-X-L/MT_A_So_MP:</b>            Sm-X-L/MT_A_So_MI_Active            Sm-X-L/MT_A_So_MI_SCCType            Sm-X-L/MT_A_So_MI_Label[1...M]            Sm-X-L/MT_A_So_MI_LSPTType[1...M]            Sm-X-L/MT_A_So_MI_CoS[1...M]            Sm-X-L/MT_A_So_PHB2TCMapping[1...M]            Sm-X-L/MT_A_So_MI_QoSEncodingMode[1...M]            Sm-X-L/MT_A_So_MI_Mode[1...M]</p> <p>Sm-X-L/MT_A_So_MI_GAL_Enable[1...M]</p>	<p><b>Sm-X-L_AP:</b>            Sm-X-L_AI_Data            Sm-X-L_AI_Clock            Sm-X-L_AI_FrameStart</p>

• **Processes:**

A process diagram of this function is shown in Figure 11-14.

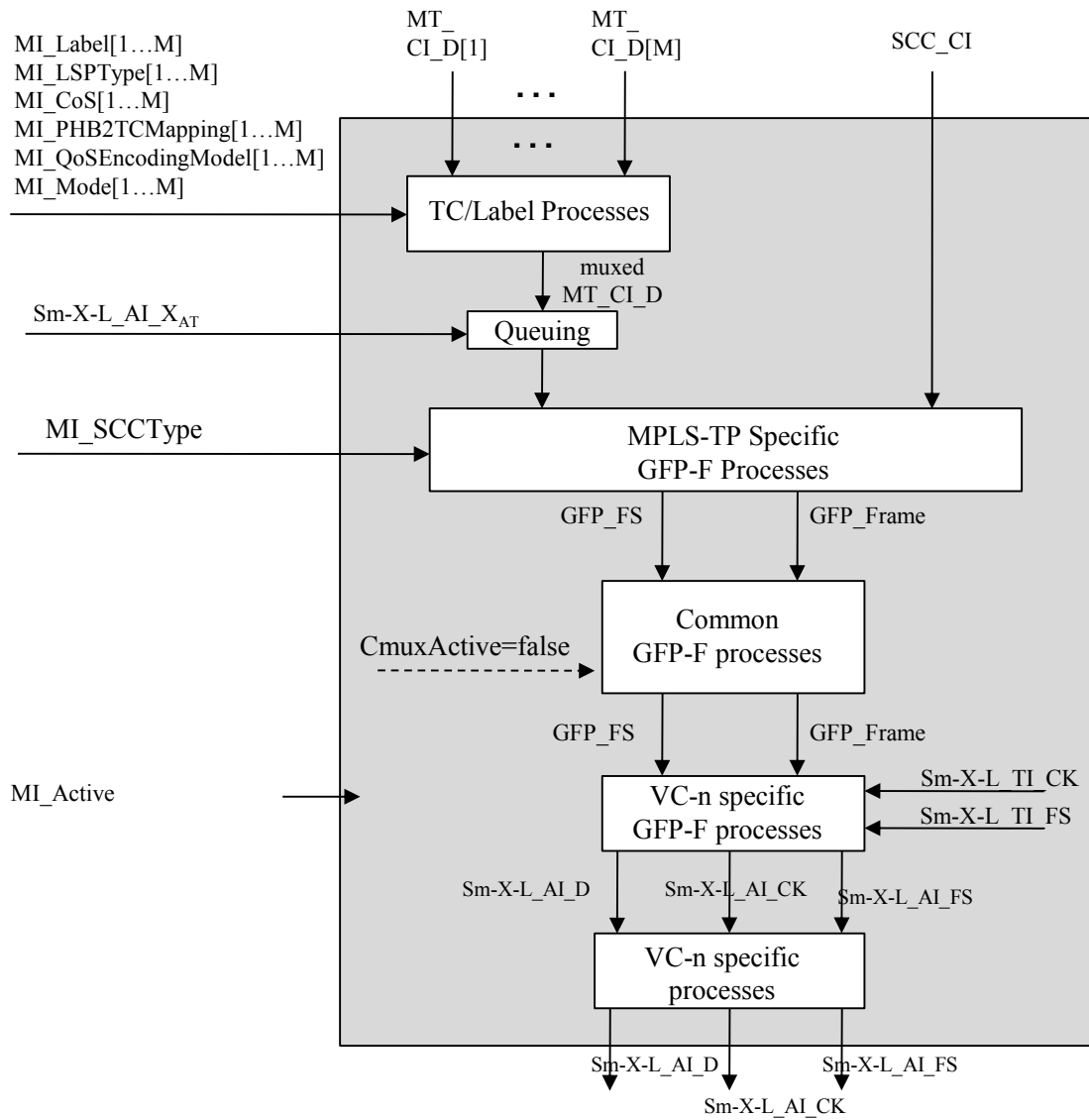


Figure 11-14/G.8121/Y.1381 – Sm-X-L/MT\_A\_So process diagram

[New: add MI\_Active]

The processes have the same definition as in 11.1.1.1.

• **Defects:**

None.

• **Consequent actions:**

None.

• **Defect correlations:**

None.

• **Performance monitoring:**

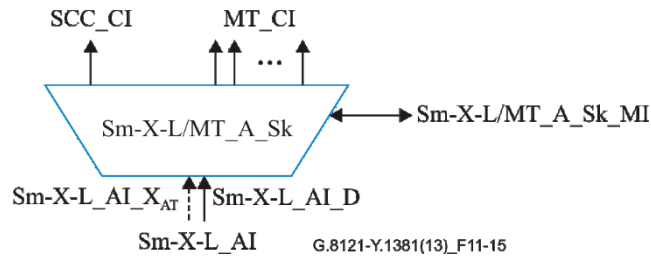
*For further study.*

**11.1.4.2 LCAS-capable VC-m to MPLS-TP adaptation sink function (Sm-X-L/MT\_A\_Sk)**

This function extracts MT\_CI information from the Sm-X-L\_AI signal (m=11, 12), delivering MT\_CI.

Data at the Sm-X-L\_AP is a VC-m-Xv (m=11, 12) but with indeterminate POH bytes J2, V5[1-4], V5[8], as per [ITU-T G.707].

• **Symbol:**



**Figure 11-15/G.8121/Y.1381 – Sm-X-L/MT\_A\_Sk symbol**

• **Interfaces:**

**Table 11-8/G.8121/Y.1381 – Sm-X-L/MT\_A\_Sk interfaces**

Inputs	Outputs
<p><b>Sm-X-L_AP:</b> Sm-X-L_AI_Data Sm-X-L_AI_Clock Sm-X-L_AI_FrameStart Sm-X-L_AI_TSF Sm-X-L_AI_XAR</p> <p><b>Sm-X-L/MT_A_Sk_MP:</b> Sm-X-L/MT_A_Sk_MI_Active Sm-X-L/MT_A_Sk_MI_SCCType Sm-X-L/MT_A_Sk_MI_Label[1...M] Sm-X-L/MT_A_Sk_MI_LSPTType[1...M] Sm-X-L/MT_A_Sk_MI_CoS[1...M] Sm-X-L/MT_A_Sk_MI_TC2PHBMapping[1...M] Sm-X-L/MT_A_Sk_MI_QoSDecodingMode[1...M] Sm-X-L/MT_A_Sk_MI_Mode[1...M]</p> <p>Sm-X-L/MT_A_Sk_MI_LCK_Period[1...M] Sm-X-L/MT_A_Sk_MI_LCK_CoS[1...M] Sm-X-L/MT_A_Sk_MI_Admin_State Sm-X-L/MT_A_Sk_MI_AIS_Period[1...M] Sm-X-L/MT_A_Sk_MI_AIS_CoS[1...M] Sm-X-L/MT_A_Sk_MI_GAL_Enable[1...M] Sm-X-L/MT_A_Sk_MI_LCK_OAM_Tool [1...M] Sm-X-L/MT_A_Sk_MI_AIS_OAM_Tool [1...M]</p>	<p><b>Each MT_CP:</b> MT_CI_Data MT_CI_iPHB MT_CI_oPHB MT_CI_SSF MI_CI_LStack</p> <p><b>SCC_CP:</b> SCC_CI_Data SCC_CI_SSF</p> <p><b>Sm-X-L/MT_A_Sk_MP:</b> Sm-X-L/MT_A_Sk_MI_AcSL Sm-X-L/MT_A_Sk_MI_AcEXI Sm-X-L/MT_A_Sk_MI_LastInvalidUPI Sm-X-L/MT_A_Sk_MI_cPLM Sm-X-L/MT_A_Sk_MI_cLFD Sm-X-L/MT_A_Sk_MI_cEXM Sm-X-L/MT_A_Sk_MI_cUPM</p>

• **Processes:**

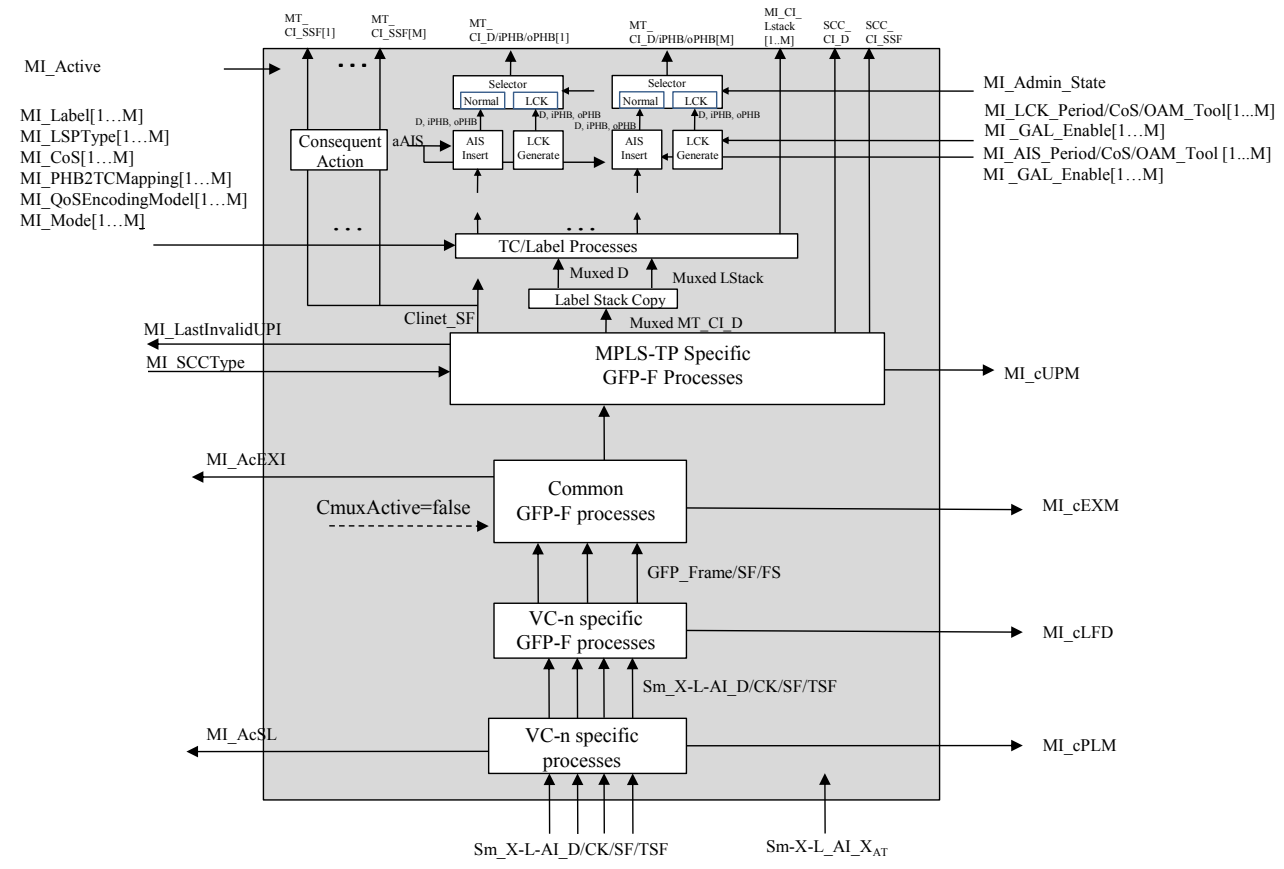


Figure 11-16/G.8121/Y.1381 – Sm-X-L/MT\_A\_Sk process diagram

[New: add Active/Remove APS, GFP Length]

See process diagram and process description in 11.1.1.2. The additional Sm-X-L\_AI\_XAR interface is not connected to any of the internal processes.

• **Defects:**

dPLM – See 6.2.4.2 in [ITU-T G.806].

dLFD – See 6.2.5.2 in [ITU-T G.806].

dUPM – See 8.4.2.

dEXM – See 6.2.4.4 in [ITU-T G.806].

• **Consequent actions:**

The function shall perform the following consequent actions:

aSSF ← AI\_TSF or dPLM or dLFD or dUPM or dEXM

aAIS ← AI\_ or dPLM or dLFD or dUPM or dEXM

• **Defect correlations:**

The function shall perform the following defect correlations to determine the most probable fault cause (see 6.4 in [ITU-T G.806]). This fault cause shall be reported to the EMF.

cPLM ← dPLM and (not AI\_TSF)

cLFD ← dLFD and (not dPLM) and (not AI\_TSF)

cEXM ← dEXM and (not dPLM) and (not dLFD) and (not AI\_TSF)

cUPM ← dUPM and (not dEXM) and (not dPLM) and (not dLFD) and (not AI\_TSF)

• **Performance monitoring:**

*For further study.*

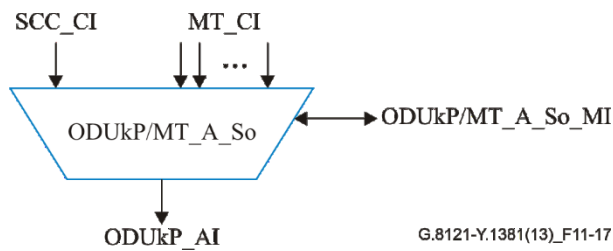
**11.2 OTH to MPLS-TP Adaptation function (O/MT\_A)**

**11.2.1 ODU<sub>k</sub> to MPLS-TP Adaptation functions**

**11.2.1.1 ODU<sub>k</sub> to MPLS-TP adaptation source function (ODU<sub>k</sub>P/MT\_A\_So)**

The ODU<sub>k</sub>P/MT\_A\_So function creates the ODU<sub>k</sub> signal from a free running clock. It maps the MT\_CI information into the payload of the OPU<sub>k</sub>, adds OPU<sub>k</sub> Overhead (RES, PT) and default ODU<sub>k</sub> Overhead.

**Symbol:**



**Figure 11-17/G.8121/Y.1381 – ODU<sub>k</sub>P/MT\_A\_So symbol**

**Interfaces:**

**Table 11-9/G.8121/Y.1381 – ODU<sub>k</sub>P/MT\_A\_So interfaces**

Inputs	Outputs
<p><b>Each MT_CP:</b>                      MT_CI_Data                      MT_CI_iPHB                      MT_CI_oPHB  <b>SCC_CP:</b>                      SCC_CI_Data  <b>ODU<sub>k</sub>P/MT_A_So_MP:</b>ODU<sub>k</sub>P/MT_A_So_MI_Active                      ODU<sub>k</sub>P/MT_A_So_MI_SCCType                      ODU<sub>k</sub>P/MT_A_So_MI_Label[1...M]                      ODU<sub>k</sub>P/MT_A_So_MI_LSPTType[1...M]</p>	<p><b>ODU<sub>k</sub>P_AP:</b>                      ODU<sub>k</sub>P_AI_Data                      ODU<sub>k</sub>P_AI_Clock                      ODU<sub>k</sub>P_AI_FrameStart                      ODU<sub>k</sub>P_AI_MultiFrameStart</p>



ODUkP/MT_A_So_MI_CoS[1...M] ODUkP/MT_A_So_PHB2TCMapping[1...M] ODUkP/MT_A_So_MI_QoSEncodingMode[1...M] ODUkP/MT_A_So_MI_Mode[1...M]  ODUkP/MT_A_So_MI_GAL_Enable[1...M]	
--	--

**Processes:**

A process diagram of this function is shown in Figure 11-18.

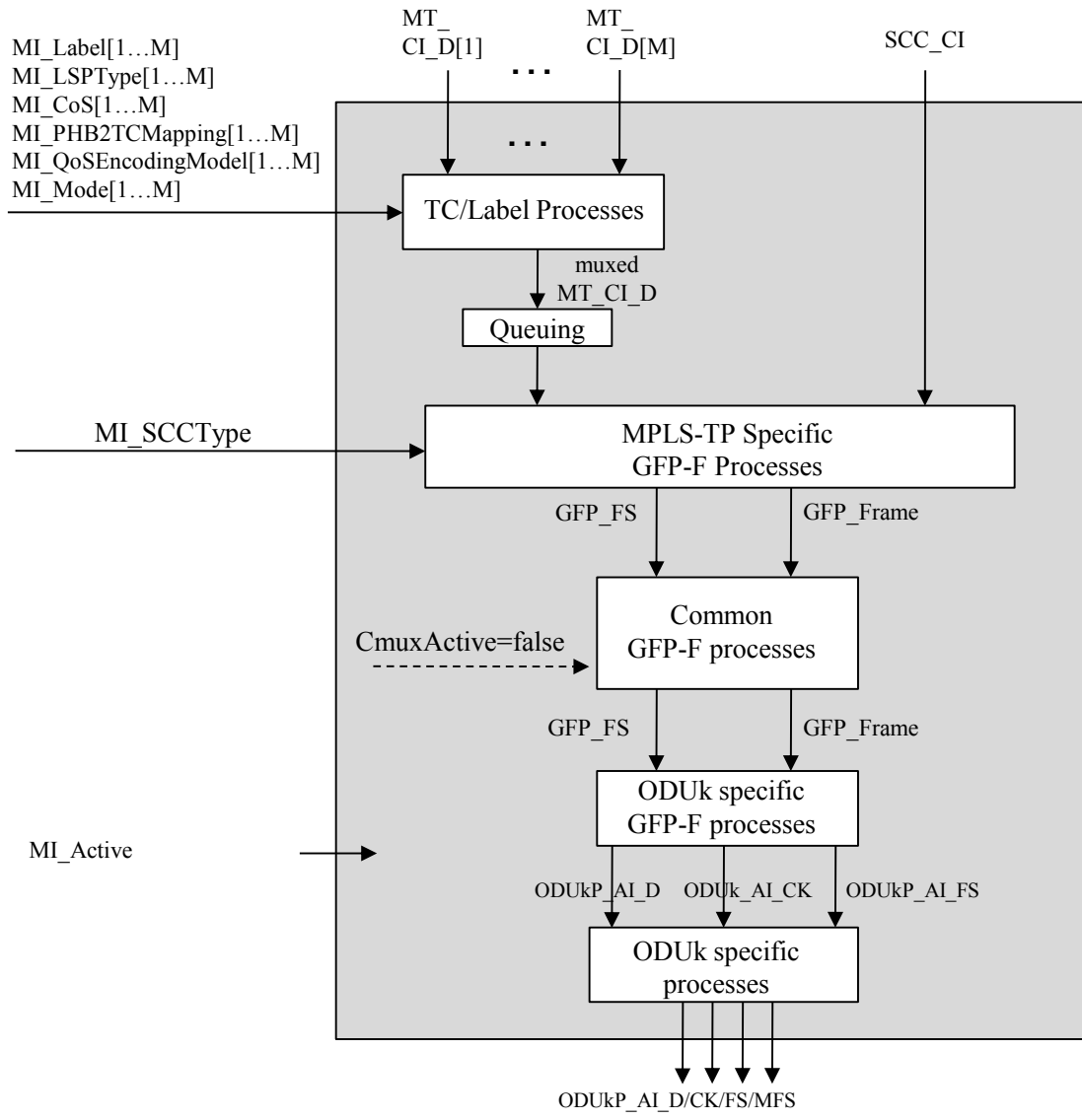


Figure 11-18/G.8121/Y.1381 – ODUkP/MT\_A\_So process diagram

[New: add Active]

– TC/Label processes:

See 8.2.1.

– *Queuing process:*

See 8.3.

– *MPLS-TP-specific GFP-F source process:*

See 8.4.1.

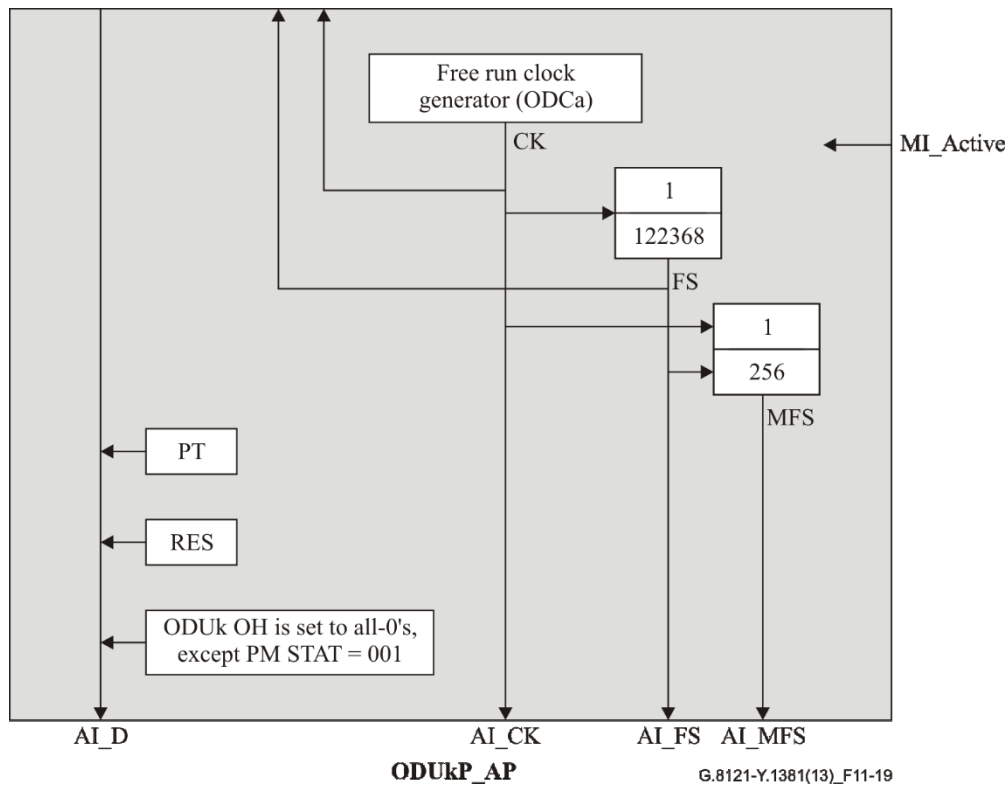
– *Common GFP source process:*

See 8.5.3.1 in [ITU-T G.806]. GFP channel multiplexing is not supported (CMuxActive=false).

– *ODUk specific GFP source process:*

See 8.5.2.1/G.806. The GFP frames are mapped into the ODUk payload area according to 17.3 in [ITU-T G.709].

– *ODUk specific source process:*



**Figure 11-19/G.8121/Y.1381 – ODUkP specific source processes**

**Clock and (Multi)Frame Start signal generation:** The function shall generate a local ODUk clock (ODUkP\_AI\_CK) of " $239/(239 - k) * 4^{(k-1)} * 2\,488\,320\text{ kHz} \pm 20\text{ ppm}$ " from a free running oscillator. The jitter and wander requirements as defined in Annex A in [ITU-T G.8251] (ODCa clock) apply.

The function shall generate the (multi)frame start reference signals AI\_FS and AI\_MFS for the ODUk signal. The AI\_FS signal shall be active once per 122368 clock cycles. AI\_MFS shall be active once every 256 frames.

**PT:** The payload type information is derived directly from the Adaptation function type. The value for "GFP mapping" shall be inserted into the PT byte position of the PSI overhead as defined in 15.9.2.1.1 in [ITU-T G.709].

**RES:** The function shall insert all-0's into the RES bytes.

All other bits of the ODUk overhead should be sourced as "0"s, except the ODUk-PM STAT field which should be set to the value "normal path signal" (001).

**Defects:**

*None.*

**Consequent actions:**

*None.*

**Defect correlations:**

*None.*

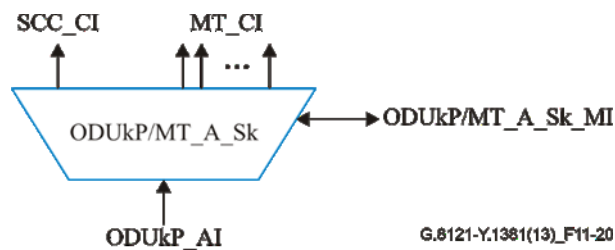
**Performance monitoring:**

*For further study.*

**11.2.1.2 ODUk to MPLS-TP adaptation sink function (ODUkP/MT\_A\_Sk)**

The ODUkP/MT\_A\_Sk extracts MT\_CI information from the ODUkP payload area. It extracts the OPUk Overhead (PT and RES) and monitors the reception of the correct payload type.

**Symbol:**



**Figure 11-20/G.8121/Y.1381 – ODUkP/MT\_A\_Sk symbol**

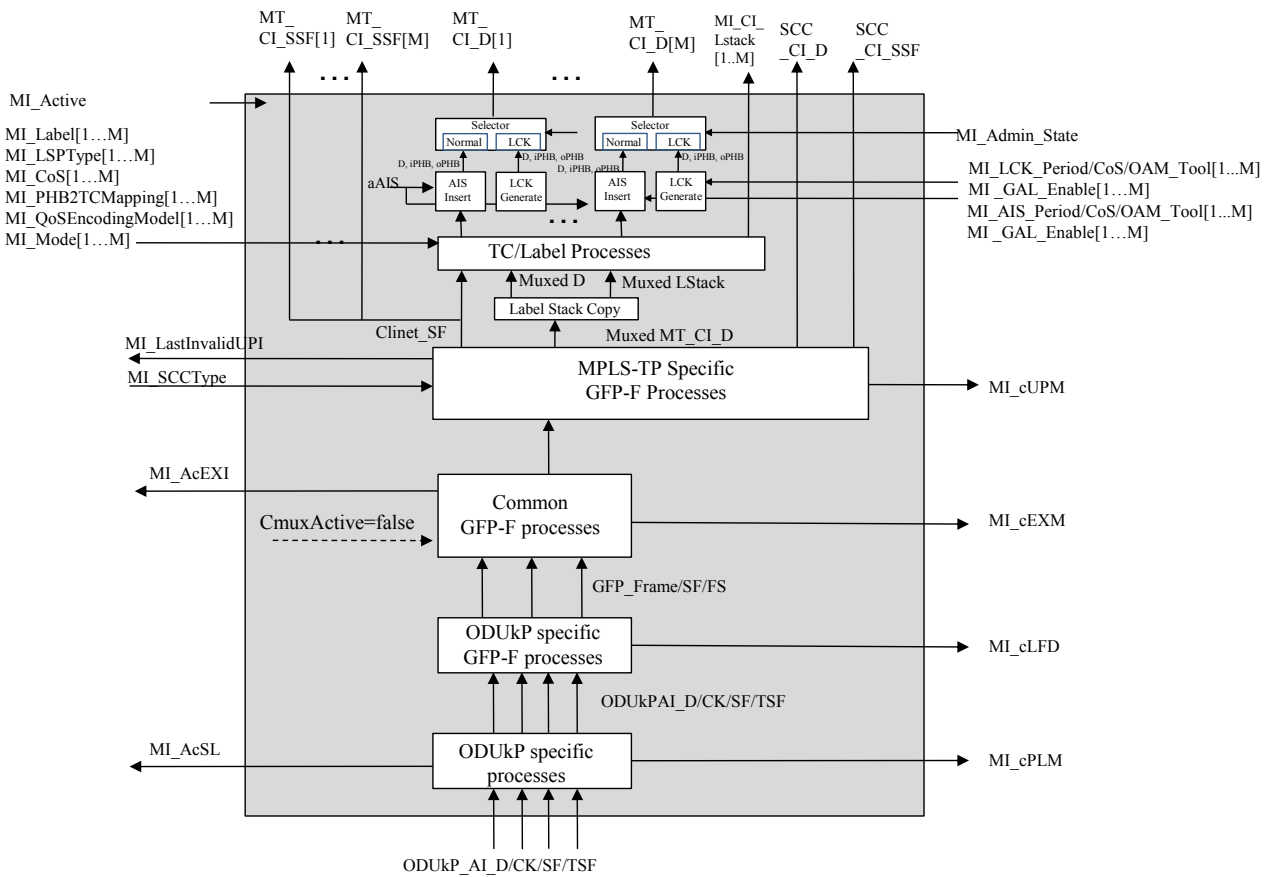
**Interfaces:**

**Table 11-10/G.8121/Y.1381 – ODUkP/MT\_A\_Sk interfaces**

Inputs	Outputs
<p><b>ODUkP_AP:</b>            ODUkP_AI_Data            ODUkP_AI_ClocK            ODUkP_AI_FrameStart            ODUkP_AI_MultiFrameStart            ODUkP_AI_TSF  <b>ODUkP/MT_A_Sk_MP:</b>ODUkP/MT_A_Sk_MI_Active            ODUkP/MT_A_Sk_MI_SCCType            ODUkP/MT_A_Sk_MI_Label[1...M]            ODUkP/MT_A_Sk_MI_LSPTtype[1...M]            ODUkP/MT_A_Sk_MI_CoS[1...M]            ODUkP/MT_A_Sk_MI_TC2PHBMapping[1...M]            ODUkP/MT_A_Sk_MI_QoSDecodingMode[1...M]            ODUkP/MT_A_Sk_MI_Mode[1...M]</p> <p>ODUkP/MT_A_Sk_MI_LCK_Period[1...M]            ODUkP/MT_A_Sk_MI_LCK_CoS[1...M]            ODUkP/MT_A_Sk_MI_Admin_State            ODUkP/MT_A_Sk_MI_AIS_Period[1...M]            ODUkP/MT_A_Sk_MI_AIS_CoS[1...M]            ODUkP/MT_A_Sk_MI_GAL_Enable[1...M]            ODUkP/MT_A_Sk_MI_LCK_Tool[1...M]            ODUkP/MT_A_Sk_MI_AIS_Tool[1...M]</p>	<p><b>Each MT_CP:</b>            MT_CI_Data            MT_CI_iPHB            MT_CI_oPHB            MT_CI_SSF            MT_CI_LStack</p> <p><b>SCC_CP:</b>            SCC_CI_Data            SCC_CI_SSF</p> <p><b>ODUkP/MT_A_Sk_MP:</b>            ODUkP/MT_A_Sk_MI_AcPT            ODUkP/MT_A_Sk_MI_AcEXI            ODUkP/MT_A_Sk_MI_LastInvalidUPI            ODUkP/MT_A_Sk_MI_cPLM            ODUkP/MT_A_Sk_MI_cLFD            ODUkP/MT_A_Sk_MI_cEXM            ODUkP/MT_A_Sk_MI_cUPM</p>

**Processes:**

A process diagram of this function is shown in Figure 11-21.



**Figure 11-21/G.8121/Y.1381 – ODUkP/MT\_A\_Sk process diagram**

[New: add Active/Remove APS, GFP Length]

– Selector generation process:

See 8.6.1 The normal CI is blocked if Admin\_State = LOCKED.

– AIS Insert process:

See 8.6.2. There is a single AIS Insert process for each MT.

– LCK generation process:

See 8.6.3. There is a single LCK Insert process for each MT.

– TC/Label processes:

See 8.2.2.

– Label Stack Copy process:

See 8.2.3.

– *MPLS-TP-specific GFP-F sink process:*

See 8.4.2.

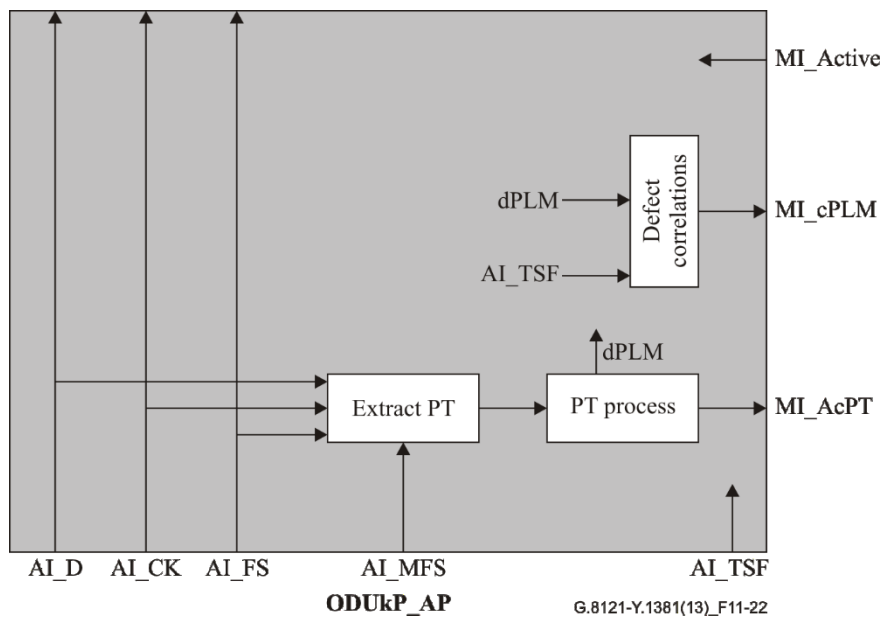
– *Common GFP sink process:*

See 8.5.3.2 in [ITU-T G.806]. GFP channel multiplexing is not supported (CMuxActive=false).

– *ODUk specific GFP sink process:*

See 8.5.2.2 in [ITU-T G.806]. The GFP frames are demapped from the ODUk payload area according to 17.3 in [ITU-T G.709].

– *ODUk-specific sink process:*



**Figure 11-22/G.8121/Y.1381 – ODUkP specific sink processes**

**PT:** The function shall extract the PT byte from the PSI overhead as defined in 8.7.1 in [ITU-T G.798]. The payload type value for "GFP mapping" in 15.9.2.1.1 in [ITU-T G.709] shall be expected. The accepted PT value is available at the MP (MI\_AcPT) and is used for PLM defect detection.

**RES:** The value in the RES bytes shall be ignored.

**Defects:**

dPLM – See 6.2.4.1 in [ITU-T G.798].

dLFD – See 6.2.5.2 in [ITU-T G.806].

dEXM – See 6.2.4.4 in [ITU-T G.806].

dUPM – See 8.4.2.

**Consequent actions:**

The function shall perform the following consequent actions:

aSSF ← AI\_TSF or dPLM or dLFD or dUPM or dEXM

aAIS ← AI\_TSF or dPLM or dLFD or dUPM or dEXM

**Defect correlations:**

The function shall perform the following defect correlations to determine the most probable fault cause (see 6.4/G.806). This fault cause shall be reported to the EMF.

cPLM ← dPLM and (not AI\_TSF)

cLFD ← dLFD and (not dPLM) and (not AI\_TSF)

cEXM ← dEXM and (not dPLM) and (not dLFD) and (not AI\_TSF)

cUPM ← dUPM and (not dEXM) and (not dPLM) and (not dLFD) and (not AI\_TSF)

**Performance monitoring:**

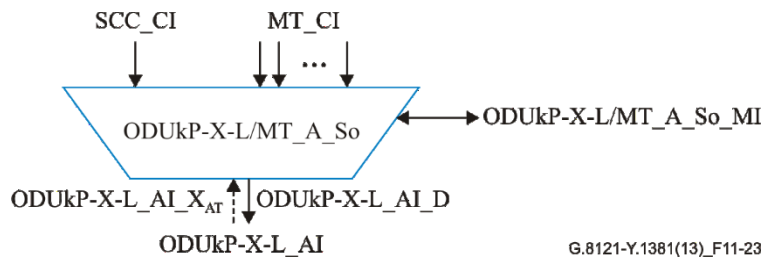
*For further study.*

**11.2.2 LCAS-capable ODU<sub>k</sub> to MPLS-TP Adaptation functions (ODU<sub>k</sub>P-X-L/MT\_A; k=1,2,3)**

**11.2.2.1 LCAS-capable ODU<sub>k</sub> to MPLS-TP adaptation source function (ODU<sub>k</sub>P-X-L/MT\_A\_So)**

The ODU<sub>k</sub>P-X-L/MT\_A\_So function creates the ODU<sub>k</sub>-X-L signal from a free running clock. It maps the MT\_CI information into the payload of the OPU<sub>k</sub>-X<sub>v</sub> (k = 1, 2, 3), adds OPU<sub>k</sub>-X<sub>v</sub> Overhead (RES, vcPT).

**Symbol:**



**Figure 11-23/G.8121/Y.1381 – ODU<sub>k</sub>P-X-L/MT\_A\_So symbol**

**Interfaces:**

**Table 11-11/G.8121/Y.1381 – ODU<sub>k</sub>P-X-L/MT\_A\_So interfaces**

Inputs	Outputs
<p><b>Each MT_CP:</b> MT_CI_Data MT_CI_iPHB MT_CI_oPHB</p> <p><b>SCC_CP:</b> SCC_CI_Data</p>	<p><b>ODU<sub>k</sub>P-X-L_AP:</b> ODU<sub>k</sub>P-X-L_AI_Data ODU<sub>k</sub>P-X-L_AI_Clock ODU<sub>k</sub>P-X-L_AI_FrameStart ODU<sub>k</sub>P-X-L_AI_MultiFrameStart</p>

<p><b>ODUKP-X-L_AP:</b> ODUKP-X-L_AI_XAT</p> <p><b>ODUKP-X-L/MT_A_So_MP:</b> ODUKP-X-L/MT_A_So_MI_Active ODUKP-X-L/MT_A_So_MI_SCCType ODUKP-X-L/MT_A_So_MI_Label[1...M] ODUKP-X-L/MT_A_So_MI_LSPTType[1...M] ODUKP-X-L/MT_A_So_MI_CoS[1...M] ODUKP-X-L/MT_A_So_PHB2TCMapping[1...M] ODUKP-X-L/MT_A_So_MI_QoSEncodingMode[1...M] ODUKP-X-L /MT_A_So_MI_Mode[1...M]</p> <p>ODUKP-X-L /MT_A_So_MI_GAL_Enable[1...M]</p>	
--	--

**Processes:**

A process diagram of this function is shown in Figure 11-24.



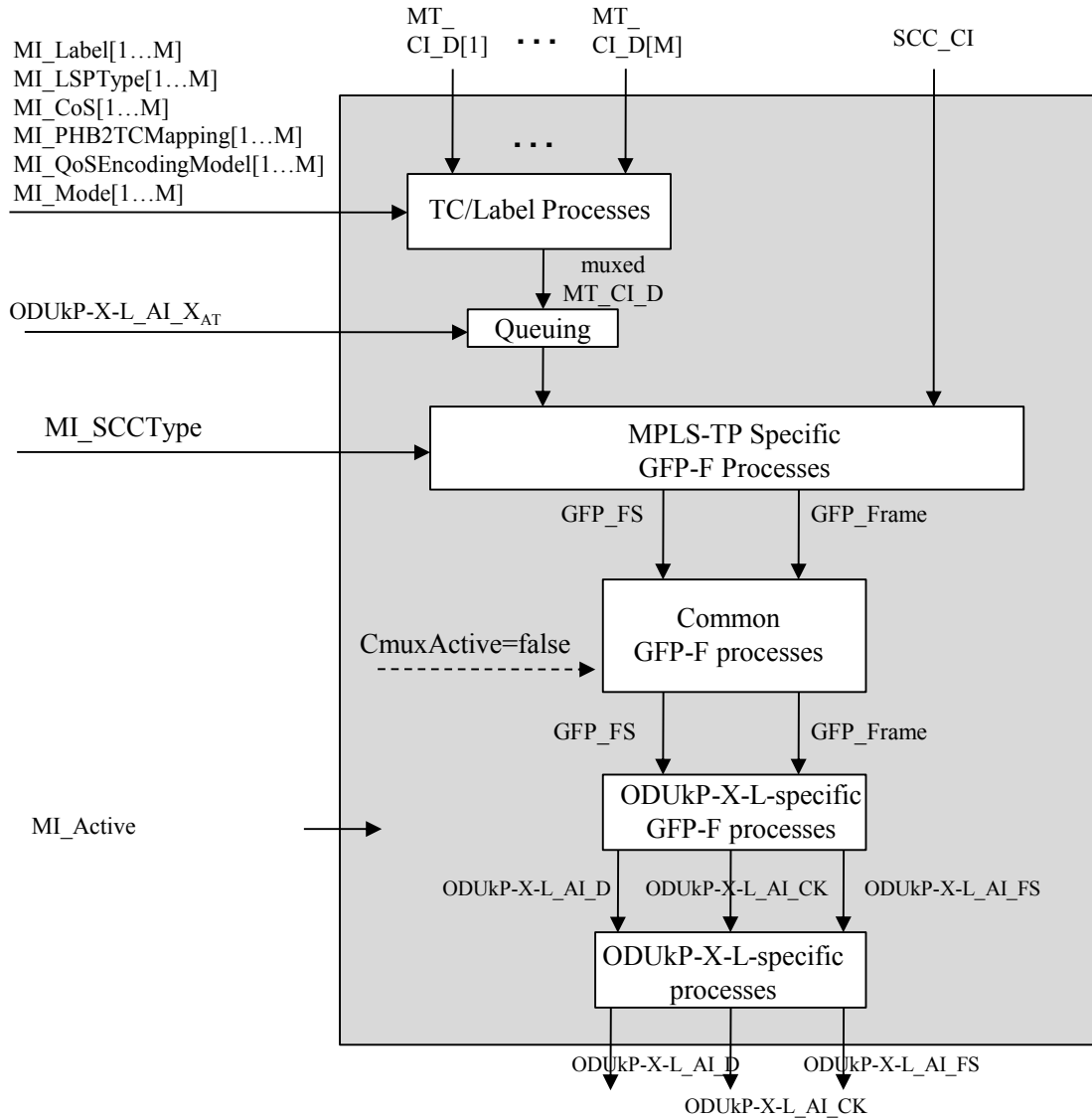
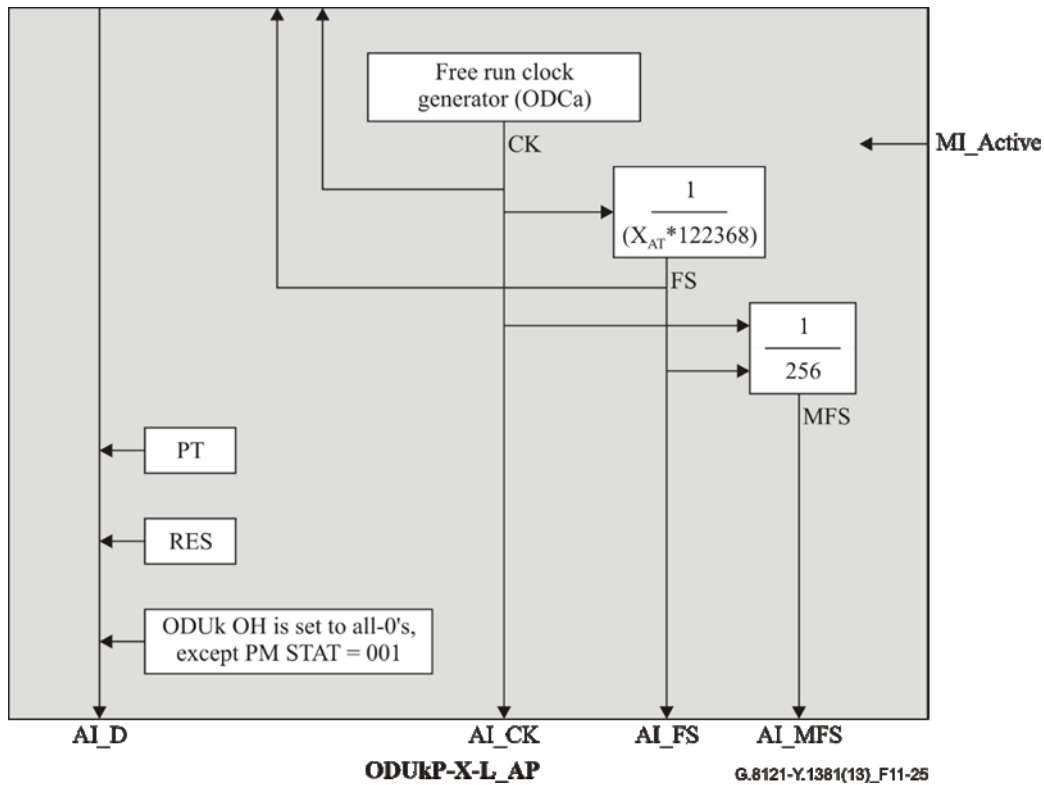


Figure 11-24/G.8121/Y.1381 – ODUkP-X-L/MT\_A\_So process diagram  
[add MI\_Active]

The processes have the same definition as in 11.2.1.1.

**ODUkP-X-L specific source process:**



**Figure 11-25/G.8121/Y.1381 – ODUkP-X-L specific source processes**

**Clock and (Multi)Frame Start signal generation:** The function shall generate a local ODUk clock (ODUKP\_AI\_CK) of " $X_{AT} * 239 / (239 - k) * 4^{(k-1)} * 2\,488\,320 \text{ kHz} \pm 20 \text{ ppm}$ " from a free running oscillator. The jitter and wander requirements as defined in Annex A in [ITU-T G.8251] (ODCa clock) apply.

The function shall generate the (multi)frame start reference signals AI\_FS and AI\_MFS for the ODUk signal. The AI\_FS signal shall be active once per 122368 clock cycles. AI\_MFS shall be active once every 256 frames.

**vcPT:** The payload type information is derived directly from the Adaptation function type. The value for “GFP mapping” shall be inserted into the vcPT byte position of the PSI overhead as defined in 18.1.2.2 in [ITU-T G.709].

**RES:** The function shall insert all-0's into the RES bytes.

**Defects:**

*None.*

**Consequent actions:**

*None.*

**Defect correlations:**

*None.*

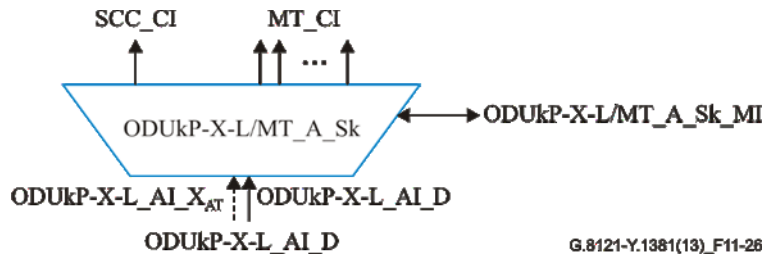
**Performance monitoring:**

*For further study.*

### 11.2.2.2 LCAS-capable ODUk to MPLS-TP adaptation sink function (ODUkP-X-L/MT\_A\_Sk)

The ODUkP-X-L/MT\_A\_Sk extracts MT\_CI information from the ODUkP-Xv payload area. It extracts the OPUk-Xv Overhead (vcPT and RES) and monitors the reception of the correct payload type.

**Symbol:**



G.8121-Y.1381(13)\_F11-28

Figure 11-26/G.8121/Y.1381 – ODUkP-X-L/MT\_A\_Sk symbol]

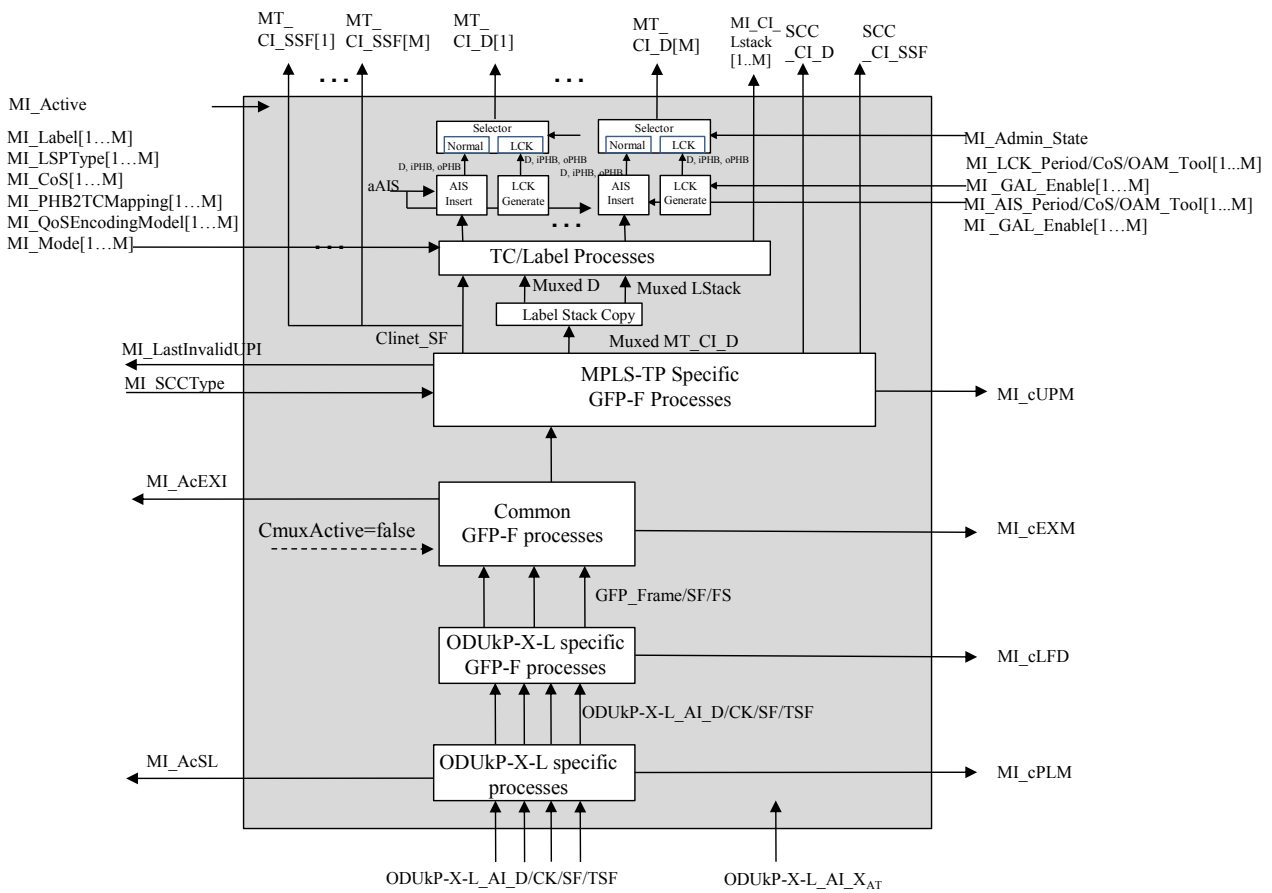
**Interfaces:**

Table 11-12/G.8121/Y.1381 – ODUkP-X-L/MT\_A\_Sk interfaces

Inputs	Outputs
<p><b>ODUkP-X-L_AP:</b>            ODUkP-X-L_AI_Data            ODUkP-X-L_AI_Clock            ODUkP-X-L_AI_FrameStart            ODUkP-X-L_AI_MultiFrameStart            ODUkP-X-L_AI_TSF            ODUkP-X-L_AI_X_AR</p> <p><b>ODUkP-X-L/MT_A_Sk_MP:</b>            ODUkP-X-L/MT_A_Sk_MI_Active            ODUkP-X-L/MT_A_Sk_MI_SCCType            ODUkP-X-L/MT_A_Sk_MI_Label[1...M]            ODUkP-X-L/MT_A_Sk_MI_LSPTType[1...M]            ODUkP-X-L/MT_A_Sk_MI_CoS[1...M]            ODUkP-X-L/MT_A_Sk_MI_TC2PHBMapping[1...M]            ODUkP-X-L/MT_A_Sk_MI_QoSDecodingMode[1...M]            ODUkP-X-L/MT_A_Sk_MI_Mode[1...M]</p> <p>ODUkP-X-L/MT_A_Sk_MI_LCK_Period[1...M]            ODUkP-X-L/MT_A_Sk_MI_LCK_CoS[1...M]            ODUkP-X-L/MT_A_Sk_MI_Admin_State            ODUkP-X-L/MT_A_Sk_MI_AIS_Period[1...M]            ODUkP-X-L/MT_A_Sk_MI_AIS_CoS[1...M]            ODUkP-X-L/MT_A_Sk_MI_GAL_Enable[1...M]            ODUkP-X-L/MT_A_Sk_MI_LCK_Tool[1...M]            ODUkP-X-L/MT_A_Sk_MI_AIS_Tool[1...M]</p>	<p><b>Each MT_CP:</b>            MT_CI_Data            MT_CI_iPHB            MT_CI_oPHB            MT_CI_SSF            MT_CI_LStack</p> <p><b>SCC_CP:</b>            SCC_CI_Data            SCC_CI_SSF</p> <p><b>ODUkP-X-L/MT_A_Sk_MP:</b>            ODUkP-X-L/MT_A_Sk_MI_AcSL            ODUkP-X-L/MT_A_Sk_MI_AcVcPT            ODUkP-X-L/MT_A_Sk_MI_AcEXI            ODUkP-X-L/MT_A_Sk_MI_LastInvalidUPI            ODUkP-X-L/MT_A_Sk_MI_cVcPLM            ODUkP-X-L/MT_A_Sk_MI_cLFD            ODUkP-X-L/MT_A_Sk_MI_cEXM            ODUkP-X-L/MT_A_Sk_MI_cUPM</p>

**Processes:**

A process diagram of this function is shown in Figure 11-27



**Figure 11-27/G.8121/Y.1381 – ODUkP-X-L/MT\_A\_Sk process diagram**

[New: add MI\_Active, Remove APS, GEP\_Length]

See process diagram and process description in 11.2.1.2. The additional ODUkP-X-L\_AI\_XAR interface is not connected to any of the internal processes.

**ODUkP-X-L specific sink process:**

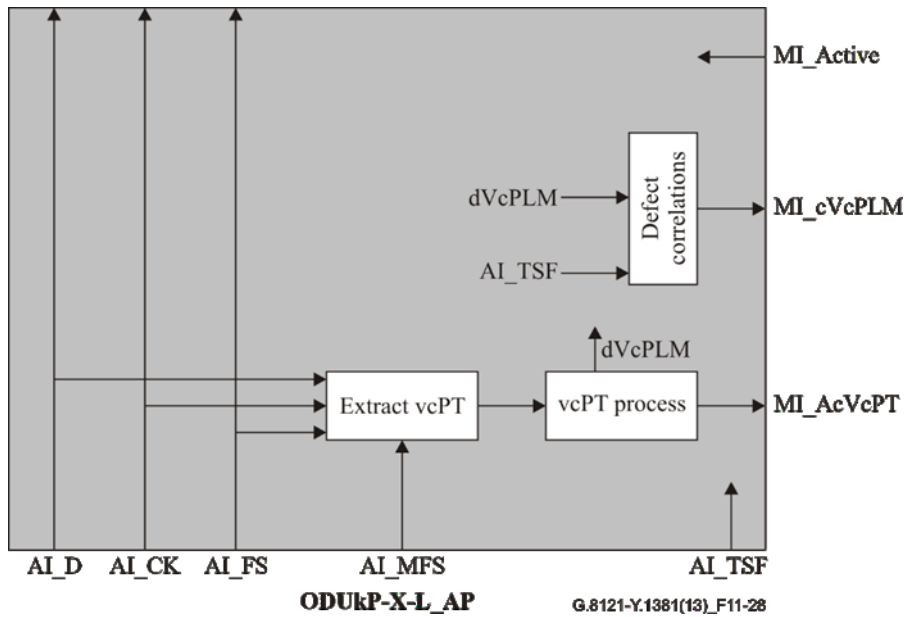


Figure 11-28/G.8121/Y.1341 – ODUkP-X-L specific sink processes

**PT:** The function shall extract the vcPT byte from the PSI overhead as defined in 8.7.3 in [ITU-T G.798]. The payload type value for "GFP mapping" in 18.1.2.2 in [ITU-T G.709] shall be expected. The accepted PT value is available at the MP (MI\_AcPT) and is used for PLM defect detection.

**RES:** The value in the RES bytes shall be ignored.

**Defects:**

dVcPLM – See 6.2.4.2 in [ITU-T G.798].

dLFD – See 6.2.5.2 in [ITU-T G.806].

dUPM – See 8.4.2.

dEXM – See 6.2.4.4 in [ITU-T G.806].

**Consequent actions:**

The function shall perform the following consequent actions:

aSSF ← AI\_TSF or dVcPLM or dLFD or dUPM or dEXM

aAIS ← AI\_TSF or dVcPLM or dLFD or dUPM or dEXM

**Defect correlations:**

The function shall perform the following defect correlations to determine the most probable fault cause (see 6.4 in [ITU-T G.806]). This fault cause shall be reported to the EMF.

cVcPLM ← dVcPLM and (not AI\_TSF)

cLFD ← dLFD and (not dVcPLM) and (not AI\_TSF)

cEXM ← dEXM and (not dVcPLM) and (not dLFD) and (not AI\_TSF)

cUPM ← dUPM and (not dEXM) and (not dVcPLM) and (not dLFD) and (not AI\_TSF)

**Performance monitoring:**

For further study.

### 11.2.3 HAO capable ODUk to MPLS-TP Adaptation functions (ODUkP-h/MT\_A; k=ODUflex)

#### 11.2.3.1 HAO capable ODUk to MPLS-TP adaptation source function (ODUkP-h/MT\_A\_So)

The ODUkP-h/MT\_A\_So function creates the ODUk signal from a free running clock. It maps the MT\_CI information into the payload of the OPUk (k=flex), adds OPUk Overhead (RES, PT, RCOH) and default ODUk Overhead.

**Symbol:**

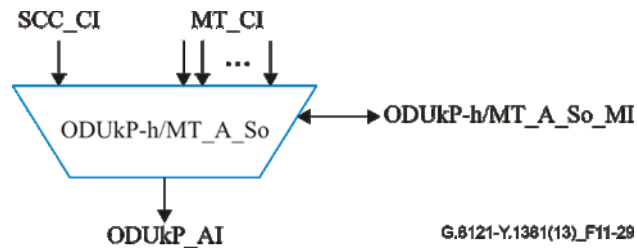


Figure 11-29/G.8121/Y.1381 – ODUkP-h/MT\_A\_So symbol

**Interfaces:**

Table 11-13/G.8121/Y.1381 – ODUkP-h/MT\_A\_So interfaces

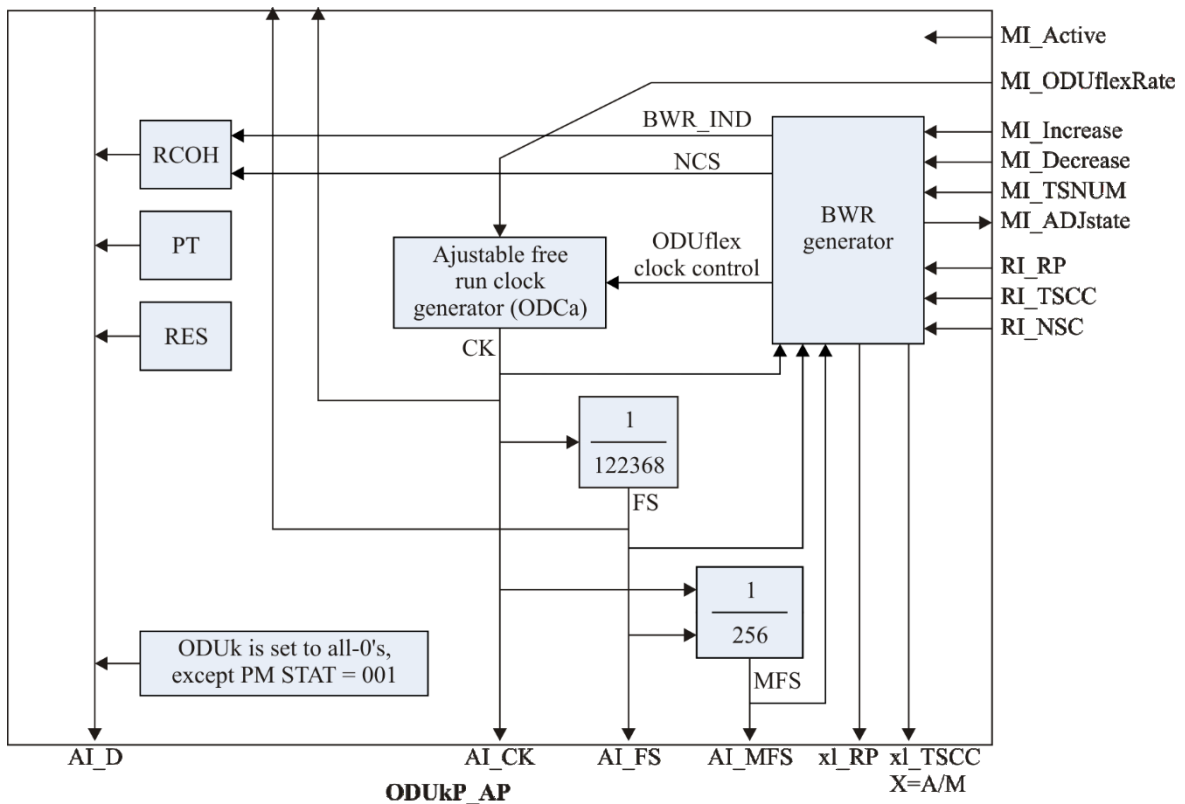
Inputs	Outputs
<p><b>Each MT_CP:</b>                      MT_CI_Data                      MT_CI_iPHB                      MT_CI_oPHB</p> <p><b>ODUkP_RP:</b>                      ODUkP_RI_RP                      ODUkP_RI_TSCC                      ODUkP_RI_NCS</p> <p><b>SCC_CP:</b>                      SCC_CI_Data</p> <p><b>ODUkP-h/MT_A_So_MP:</b>                      ODUkP-h/MT_A_So_MI_Active                      ODUkP-h/MT_A_So_MI_SCCType                      ODUkP-h/MT_A_So_MI_Label[1...M]                      ODUkP-h/MT_A_So_MI_LSPTType[1...M]                      ODUkP-h/MT_A_So_MI_CoS[1...M]                      ODUkP-h/MT_A_So_PHB2TCMapping[1...M]                      ODUkP-h/MT_A_So_MI_QoSEncodingMode[1...M]                      ODUkP-h/MT_A_So_MI_Mode[1...M]</p>	<p><b>ODUkP_AP:</b>                      ODUkP_AI_Data                      ODUkP_AI_Clock                      ODUkP_AI_FrameStart                      ODUkP_AI_MultiFrameStart                      ODUkP_(A/M)I_RP                      ODUkP_(A/M)I_TSCC</p> <p><b>ODUkP-h/MT_A_So_MP:</b>                      ODUkP-h/MT_A_So_MI_ADJSTATE</p>

ODUkP-h/MT_A_So_MI_GAL_Enable[1...M]  ODUkP-h/MT_A_So_MI_Increase ODUkP-h/MT_A_So_MI_Decrease ODUkP-h/MT_A_So_MI_TSNUM ODUkP-h/MT_A_So_MI_ODUflexRate	
NOTE - (A/M)I_xxx indicates that the xxx signal may either be an AI_xxx or a MI_xxx signal.	

**Processes:**

A process diagram of this function is shown as Figure 11-18 in clause 11.2.1.1. An ODU specific process for HAO capable adaptation function is described as below. Other processes are described in clause 11.2.1.1.

– *ODUk specific source process:*



G.8121-Y.1381(13)\_F11-30

**Figure 11-30/G.8121/Y.1381 – ODUkP (k=flex) specific source processes**

**Clock and (Multi)Frame Start signal generation:** The function shall generate a local ODUk clock with a clock rate within the minimum to maximum clock rate of the ODUflex signal as given in Table 14-2/G.798.. The jitter and wander requirements as defined in Annex A in [ITU-T G.8251] (ODCa clock) apply.

The function shall generate the (multi)frame start reference signals AI\_FS and AI\_MFS for the ODUk signal. The AI\_FS signal shall be active once per 122368 clock cycles. AI\_MFS shall be active once every 256 frames.

**PT:** The payload type information is derived directly from the Adaptation function type. The value for “GFP mapping” shall be inserted into the PT byte position of the PSI overhead as defined in 15.9.2.1.1 in [ITU-T G.709]. The PT value of a HAO capable adaptation function is the same as a non-HAO capable one.

**RES:** The function shall insert all-0's into the RES bytes.

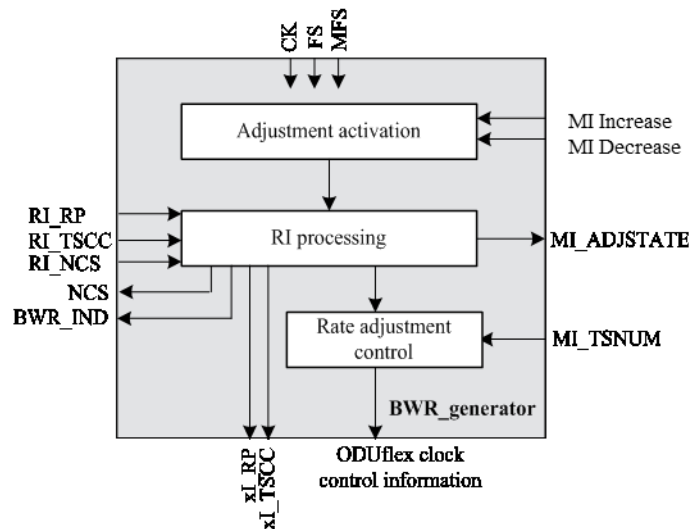
All other bits of the ODUk overhead should be sourced as "0"s, except the ODUk-PM STAT field which should be set to the value "normal path signal" (001).

**RCOH Generator :** This process inserts NCS generated by HAO process into the NCS field of the RCOH in OPUflex.

**BWR\_Generator:** This process is used for BWR protocol adjustment processing and generation of BWR protocol overhead. It contains the following processes as shown in Figure 11-31.

*Adjustment activation:* When MI ~~INCREASE-Increase~~ or MI ~~DECREASE-Decrease~~ is true, BWR protocol is activated and RI processing is started.

*Rate adjustment control:* Generates ODUflex clock control signal. Original ODUflex clock rate will gradually change to new ODUflex clock rate such that no GMP buffer overflow or underflow will occur in the ODUflex network connection. Refer to G.7044.



**Figure 11-31 – BWR\_Generator process**

~~(New: INCREASE and DECREASE → Increase and Decrease)~~

*RI processing:* This process performs BWR protocol according to RI\_RP, RI\_TSCC, RI\_NCS signals received from the BWR\_Receiver process.

- When RI processing is activated, xI\_RP and xI\_TSCC (x is A or M) signals are set to one (1).
- The value of the NCS signal is set to ACK(1) when receiving RI\_RP=1 and the value of RI\_TSCC is changed from 0 to 1.
- Rate adjustment control is activated when receiving RI\_RP=1 and RI\_TSCC=1 and RI\_NCS=ACK(1).



- BWR\_IND is set to “1” x  $\mu$ s before ODUflex signal’s bit rate adjustment starts, and is set to “0” y  $\mu$ s before ODUflex signal’s bit rate adjustment completes. x is almost equal to y and shall be in the range of 125 to 250  $\mu$ s ..
- The value of xI\_TSCC signal is set to 0 when rate adjustment is completed.
- The value of NCS signal is set to NACK(0) when receiving RI\_RP=1 and the value of RI\_TSCC is changed from 1 to 0.
- The value of RP signal is set to 0 when receiving RI\_NCS=NACK(0) and sending NCS=NACK(0).
- The completion of the resize process is reported to Network Management System when receiving RI\_RP=0.

**Defects:**

*None.*

**Consequent actions:**

*None.*

**Defect correlations:**

*None.*

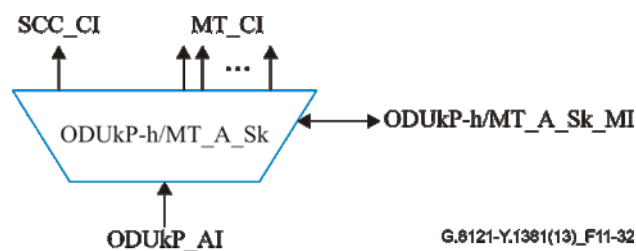
**Performance monitoring:**

*For further study.*

**11.2.3.2 HAO capable ODUk to MPLS-TP adaptation sink function (ODUkP-h/MT\_A\_Sk)**

The ODUkP-h/MT\_A\_Sk extracts MT\_CI information from the ODUkP payload area. It extracts the OPUk Overhead (PT, RCOH and RES) and monitors the reception of the correct payload type.

**Symbol:**



**Figure 11-32/G.8121/Y.1381 – ODUkP-h/MT\_A\_Sk symbol**

**Interfaces:**

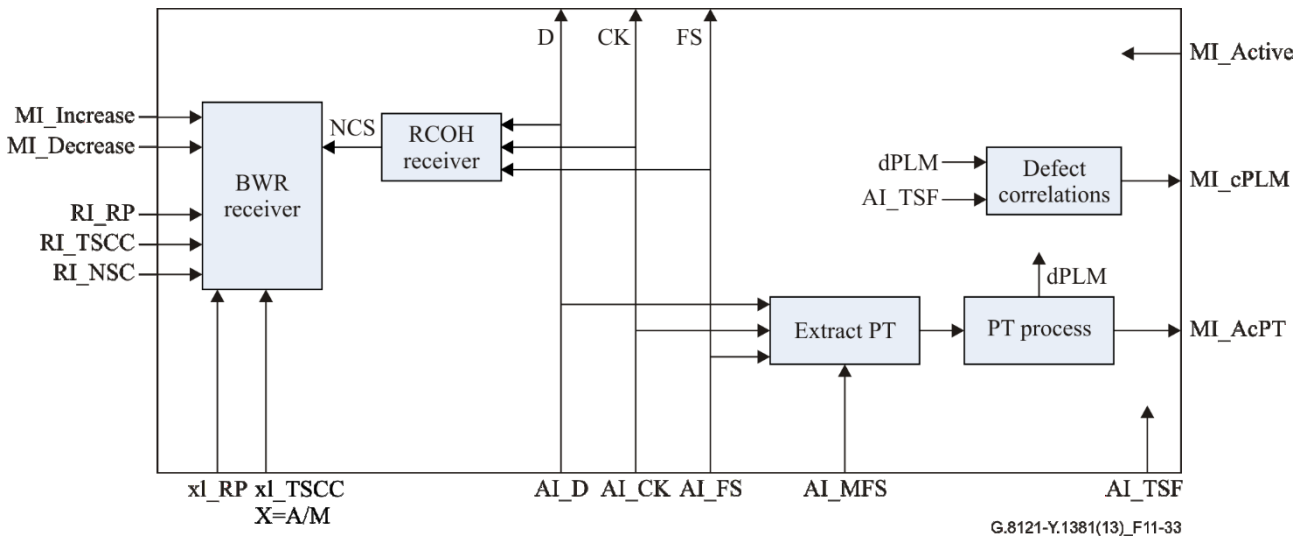
**Table 11-14/G.8121/Y.1381 – ODUkP-h/MT\_A\_Sk interfaces**

Inputs	Outputs
<p><b>ODUkP_AP:</b>  ODUkP_AI_Data  ODUkP_AI_Clock  ODUkP_AI_FrameStart  ODUkP_AI_MultiFrameStart  ODUkP_AI_TSF  ODUkP_(A/M)I_RP  ODUkP_(A/M)I_TSCC</p> <p><b>ODUkP-h/MT_A_Sk_MP:</b>  ODUkP-h/MT_A_Sk_MI_Active  ODUkP-h /MT_A_Sk_MI_SCCType  ODUkP-h /MT_A_Sk_MI_Label[1...M]  ODUkP-h /MT_A_Sk_MI_LSPTType[1...M]  ODUkP-h /MT_A_Sk_MI_CoS[1...M]  ODUkP-h /MT_A_Sk_MI_TC2PHBMapping[1...M]  ODUkP-h /MT_A_Sk_MI_QoSDecodingMode[1...M]  ODUkP/MT_A_Sk_MI_Mode[1...M]</p> <p>ODUkP-h /MT_A_Sk_MI_LCK_Period[1...M]  ODUkP-h /MT_A_Sk_MI_LCK_CoS[1...M]  ODUkP-h /MT_A_Sk_MI_LCK_Tool[1...M]  ODUkP-h /MT_A_Sk_MI_AIS_Tool[1...M]</p> <p>ODUkP-h /MT_A_Sk_MI_Admin_State  ODUkP-h /MT_A_Sk_MI_AIS_Period[1...M]  ODUkP-h /MT_A_Sk_MI_AIS_CoS[1...M]  ODUkP-h /MT_A_Sk_MI_LCK_Tool[1...M]  ODUkP-h /MT_A_Sk_MI_AIS_Tool[1...M]  ODUkP-h /MT_A_Sk_MI_GAL_Enable[1...M]</p> <p>ODUkP-h/MT_A_Sk_MI_Increase  ODUkP-h/MT_A_Sk_MI_Decrease</p>	<p><b>Each MT_CP:</b>  MT_CI_Data  MT_CI_iPHB  MT_CI_oPHB  MT_CI_SSF  MT_CI_LStack</p> <p><b>SCC_CP:</b>  SCC_CI_Data  SCC_CI_SSF</p> <p><b>ODUkP_RP:</b>  ODUkP_RI_RP  ODUkP_RI_TSCC  ODUkP_RI_NCS</p> <p><b>ODUkP-h/MT_A_Sk_MP:</b>  ODUkP-h/MT_A_Sk_MI_AcPT  ODUkP-h /MT_A_Sk_MI_AcEXI  ODUkP-h /MT_A_Sk_MI_LastInvalidUPI  ODUkP-h /MT_A_Sk_MI_cPLM  ODUkP-h /MT_A_Sk_MI_cLFD  ODUkP-h /MT_A_Sk_MI_cEXM  ODUkP-h /MT_A_Sk_MI_cUPM</p>

**Processes:**

A process diagram of this function is shown as Figure 11-21 in clause 11.2.1.2. An ODU specific process for HAO capable adaptation function is described as below. Other processes are described in clause 11.2.1.2.

– *ODUk-specific sink process:*



**Figure 11-33/G.8121/Y.1381 – ODUkP (k=flex) specific sink processes**

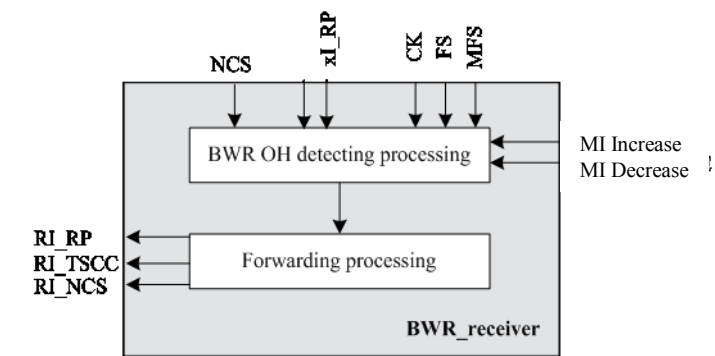
**PT:** The function shall extract the PT byte from the PSI overhead as defined in 8.7.1 in [ITU-T G.798]. The payload type value for "GFP mapping" in 15.9.2.1.1 in [ITU-T G.709] shall be expected. The accepted PT value is available at the MP (MI\_AcPT) and is used for PLM defect detection. The PT value of a hao capable adaptation function is the same as a non-hao capable one.

**RES:** The value in the RES bytes shall be ignored.

**RCOH Receiver :** This process extracts NCS from RCOH overhead area, and then forwards it to BWR\_Receiver.

**BWR\_Receiver:** This process extracts and detects the BWR protocol overhead, with the exception of the BWR\_IND signal. It is shown in Figure 11-34.

When MI Increase INCREASE or MI Decrease DECREASE is true, BWR protocol is activated and start to receive AI\_RP/MI\_RP, AI\_TSCC/MI\_TSCC from BWR\_RELAY\_Receiver process and NCS from Extract NCS process. Then the detected value of RP, TSCC and NCS are sent to BWR Generator.



**Figure 11-34 – BWR\_Receiver process**

(New: INCREASE and DECREASE → Increase and Decrease)

**Defects:**

dPLM – See 6.2.4.1 in [ITU-T G.798].

dLFD – See 6.2.5.2 in [ITU-T G.806].

dEXM – See 6.2.4.4 in [ITU-T G.806].

dUPM – See 8.4.2.

**Consequent actions:**

The function shall perform the following consequent actions:

aSSF ← AI\_TSF or dPLM or dLFD or dUPM or dEXM

aAIS ← AI\_TSF or dPLM or dLFD or dUPM or dEXM

**Defect correlations:**

The function shall perform the following defect correlations to determine the most probable fault cause (see 6.4/G.806). This fault cause shall be reported to the EMF.

cPLM ← dPLM and (not AI\_TSF)

cLFD ← dLFD and (not dPLM) and (not AI\_TSF)

cEXM ← dEXM and (not dPLM) and (not dLFD) and (not AI\_TSF)

cUPM ← dUPM and (not dEXM) and (not dPLM) and (not dLFD) and (not AI\_TSF)

**Performance monitoring:**

*For further study.*

**11.3 PDH to MPLS-TP adaptation function (P/MT\_A)**

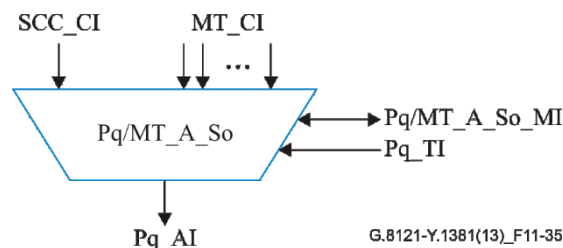
**11.3.1 Pq to MPLS-TP Adaptation functions (Pq/MT\_A; q = 11s, 12s, 31s, 32e)**

**11.3.1.1 Pq to MPLS-TP Adaptation Source function (Pq/MT\_A\_So)**

This function maps MT\_CI information onto a Pq\_AI signal (q = 11s, 12s, 31s, 32e).

Data at the Pq\_AP is a Pq (q = 11s, 12s, 31s, 32e), having a payload as described in [ITU-T G.7043] with a value of N=1. The VLI byte is reserved and not used for payload data.

**Symbol**



G.8121-Y.1381(13)\_F11-35

**Figure 11-35/G.8121/Y.1381 – Pq/MT\_A\_So symbol**

**Interfaces**

**Table 11-15/G.8121/Y.1381: Pq/MT\_A\_So interfaces**

Inputs	Outputs
<p><u>Each MT_CP:</u>                      MT_CI_Data                      MT_CI_iPHB                      MT_CI_oPHB</p> <p><u>SCC_CP:</u>                      SCC_CI_Data</p> <p><u>Pq_TP:</u>                      Pq_TI_Clock                      Pq_TI_FrameStart</p> <p><u>Pq/MT_A_So_MP:</u>                      Pq/MT_A_So_MI_Active                      Pq/MT_A_So_MI_SCCType                      Pq/MT_A_So_MI_Label[1...M]                      Pq/MT_A_So_MI_LSPTType[1...M]                      Pq/MT_A_So_MI_CoS[1...M]                      Pq/MT_A_So_PHB2TCMapping[1...M]                      Pq/MT_A_So_MI_QoSEncodingMode[1...M]                      Pq/MT_A_So_MI_Mode[1...M]</p> <p>Pq/MT_A_So_MI_GAL_Enable[1...M]</p>	<p><u>Pq_AP:</u>                      Pq_AI_Data                      Pq_AI_Clock                      Pq_AI_FrameStart</p>

## Processes

A process diagram of this function is shown in Figure 11-36.

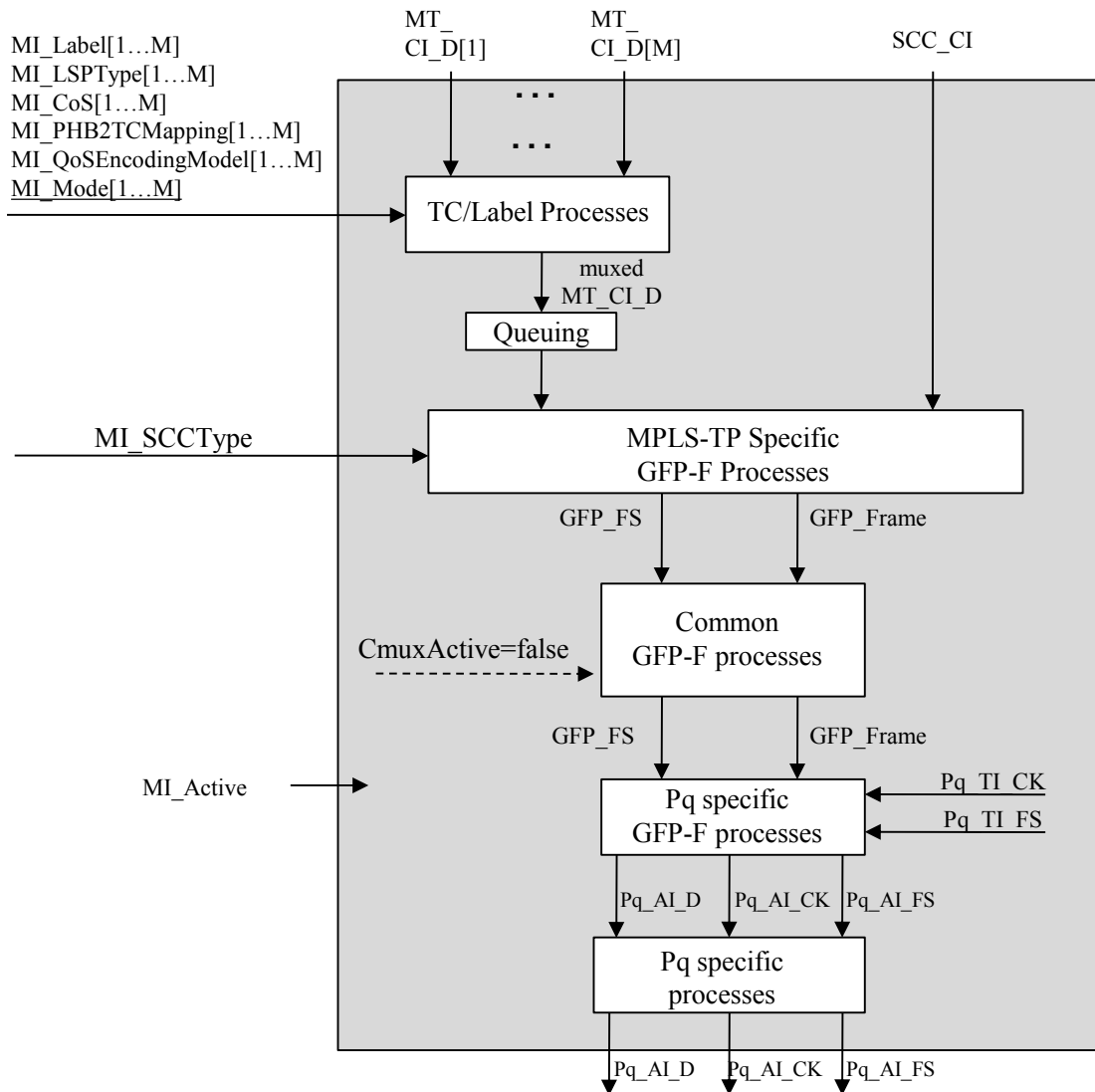


Figure 11-36/G.8121/Y.1381 – Pq/MT\_A\_So process diagram

[New: add MI\_Active]

### *TC/Label processes:*

See 8.2.1.

### *Queuing process:*

See 8.3.

### *MPLS-TP-specific GFP-F source process:*

See 8.4.1.

**Common GFP source process:**

See 8.5.3.1 in [ITU-T G.806]. GFP channel multiplexing is not supported (CMuxActive=false).

**Pq specific GFP source process:**

See 8.5.2.1 in [ITU-T G.806]. The GFP frames are mapped into the Pq payload area according to [ITU-T G.8040].

**Pq specific source process:**

Note: the VLI byte is fixed stuff equal to 0x00 at the Pq\_AP output of this function.

**P31s specific:**

**MA:** Signal label information is derived directly from the Adaptation function type. The value for “GFP mapping” in clause 2.1/G.832 is placed in the Payload Type field of the MA byte.

**Defects**

None.

**Consequent actions**

None.

**Defect correlations**

None.

**Performance monitoring**

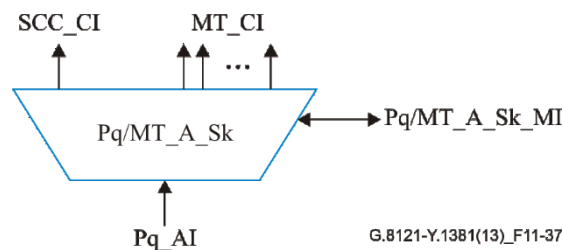
For further study.

**11.3.1.2 Pq to MPLS-TP Adaptation Sink function (Pq/MT\_A\_Sk)**

This function extracts MT\_CI information from the Pq\_AI signal (q = 11s, 12s, 31s, 32e), delivering MT\_CI.

Data at the Pq\_AP is a Pq (q = 11s, 12s, 31s, 32e), having a payload as described in [ITU-T G.7043] with a value of N=1. The VLI byte is reserved and not used for payload data.

**Symbol**



G.8121-Y.1381(13)\_F11-37

**Figure 11-37/G.8121/Y.1381 – Pq/MT\_A\_Sk symbol**

## Interfaces

**Table 11-16/G.8121/Y.1381: Pq/MT\_A\_Sk interfaces**

Inputs	Outputs
<p><u>Pq_AP:</u> Pq_AI_Data Pq_AI_ClocK Pq_AI_FrameStart Pq_AI_TSF</p> <p><u>Pq/MT_A_Sk_MP:</u> Pq/MT_A_Sk_MI_Active Pq/MT_A_Sk_MI_SCCType Pq/MT_A_Sk_MI_Label[1...M] Pq/MT_A_Sk_MI_LSPTType[1...M] Pq/MT_A_Sk_MI_CoS[1...M] Pq/MT_A_Sk_MI_TC2PHBMapping[1...M] Pq/MT_A_Sk_MI_QoSDecodingMode[1...M] Pq/MT_A_Sk_MI_Mode[1...M]</p> <p>Pq/MT_A_Sk_MI_LCK_Period[1...M] Pq/MT_A_Sk_MI_LCK_CoS[1...M] Pq/MT_A_Sk_MI_Admin_State Pq/MT_A_Sk_MI_AIS_Period[1...M] Pq/MT_A_Sk_MI_AIS_CoS[1...M] Pq/MT_A_Sk_MI_GAL_Enable [1...M] Pq/MT_A_Sk_MI_LCK_Tool[1...M] Pq/MT_A_Sk_MI_AIS_Tool[1...M]</p>	<p><u>Each MT_CP:</u> MT_CI_Data MT_CI_iPHB MT_CI_oPHB MT_CI_SSF MT_CI_LStack</p> <p><u>SCC_CP:</u> SCC_CI_Data SCC_CI_SSF</p> <p><u>Pq/MT_A_Sk_MP:</u> Pq/MT_A_Sk_MI_AcSL Pq/MT_A_Sk_MI_AcEXI Pq/MT_A_Sk_MI_LastInvalidUPI Pq/MT_A_Sk_MI_cPLM Pq/MT_A_Sk_MI_cLFD Pq/MT_A_Sk_MI_cEXM Pq/MT_A_Sk_MI_cUPM</p>

## Processes

A process diagram of this function is shown in Figure 11-38.



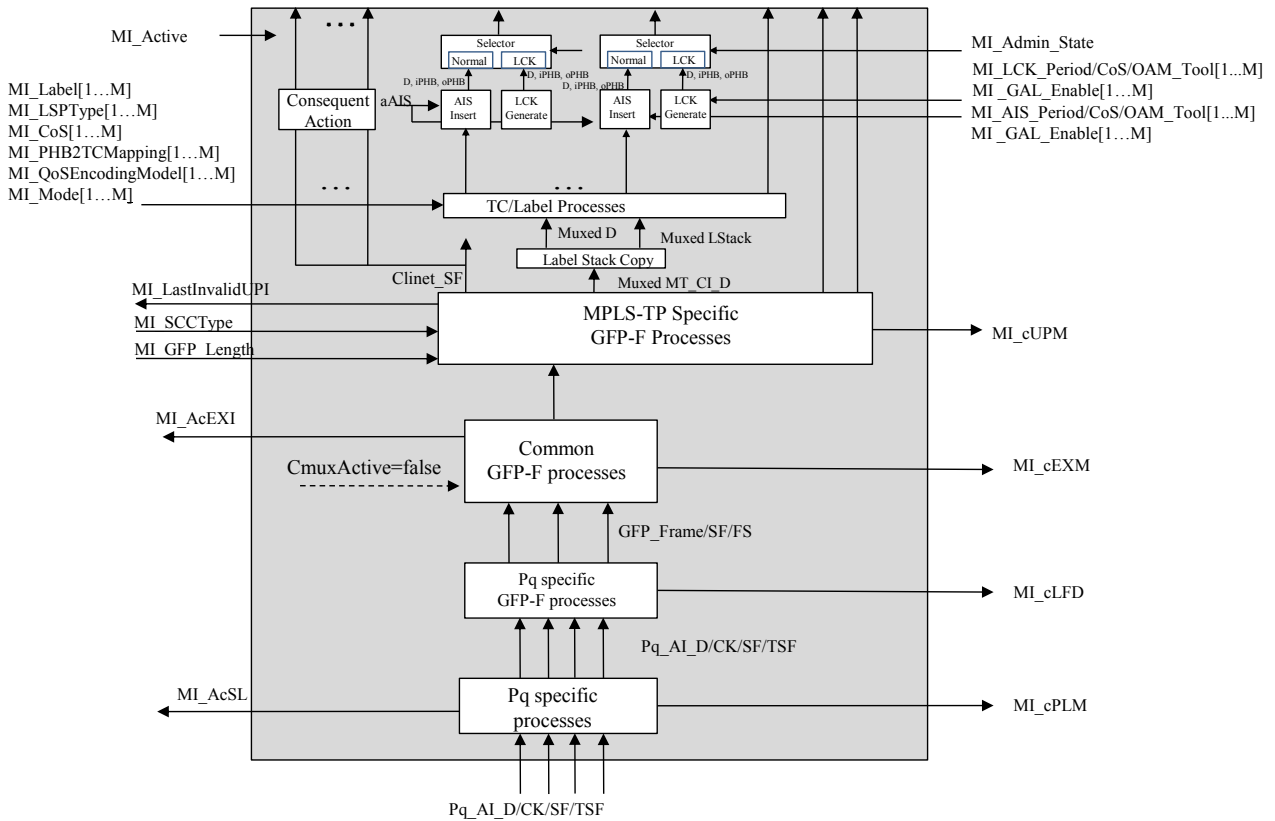


Figure 11-38/G.8121/Y.1381 – Pq/MT\_A\_Sk process diagram

[New: add Active/Remove APS, GFP Length]

– Selector generation process:

See 8.6.1 The normal CI is blocked if Admin\_State = LOCKED.

– AIS Insert process:

See 8.6.2. There is a single AIS Insert process for each MT.

– LCK generation process:

See 8.6.3. There is a single LCK Insert process for each MT.

**TC/Label processes:**

See 8.2.2.

– Label Stack Copy process:

See 8.2.3.

**MPLS-TP specific GFP-F sink process:**

See 8.4.2/G.8121/Y.1381.

**Common GFP sink process:**

See 8.5.3.1/G.806. GFP channel multiplexing is not supported (CMuxActive=false).

***Pq specific GFP sink process:***

See 8.5.2.1/G.806. The GFP frames are demapped from the Pq payload area according to G.8040/Y.1340.

***Pq specific sink process:***

Note: the VLI byte at the Pq\_AP input of this function is ignored.

***P31s specific:***

**MA:** The signal label is recovered from the Payload Type field in the MA byte as per 6.2.4.2 in [ITU-T G.806]. The signal label for “GFP mapping” in clause 2.1 in [ITU-T G.832] shall be expected. The accepted value of the signal label is also available at the P31s/ETH\_A\_Sk\_MP.

**Defects**

dPLM – See 6.2.4.2 in [ITU-T G.806].

dLFD – See 6.2.5.2 in [ITU-T G.806]

dUPM - See 8.4.2/G.8121/Y.1381

dEXM – See 6.2.4.4 in [ITU-T G.806].

Note: dPLM is only defined for q = 31s. dPLM is assumed to be false for q = 11s, 12s, 32e.

**Consequent actions**

The function shall perform the following consequent actions:

aSSF ← AI\_TSF or dPLM or dLFD or dUPM or dEXM

aAIS ← AI\_TSF or dPLM or dLFD or dUPM or dEXM

**Defect correlations**

The function shall perform the following defect correlations to determine the most probable fault cause (see 6.4/G.806). This fault cause shall be reported to the EMF.

cPLM ← dPLM and (not AI\_TSF)

cLFD ← dLFD and (not dPLM) and (not AI\_TSF)

cEXM ← dEXM and (not dPLM) and (not dLFD) and (not AI\_TSF)

cUPM ← dUPM and (not dEXM) and (not dPLM) and (not dLFD) and (not AI\_TSF)

**Performance monitoring**

For further study.

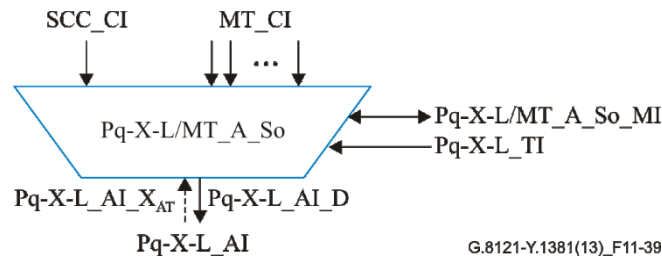
**11.3.2 LCAS-capable Pq to MPLS-TP Adaptation functions (Pq-X-L/MT\_A; q=11s, 12s, 31s, 32e)**

**11.3.2.1 LCAS-capable Pq to MPLS-TP Adaptation Source function (Pq-X-L/MT\_A\_So)**

This function maps MT\_CI information onto an Pq-X-L\_AI signal (q=11s, 12s, 31s, 32e).

Data at the Pq-X-L\_AP is a Pq-X (q = 11s, 12s, 31s, 32e), having a payload as described in [ITU-T G.7043].

**Symbol**



**Figure 11-39/G.8121/Y.1381 – Pq-X-L/MT\_A\_So symbol**

**Interfaces**

**Table 11-17/G.8121/Y.1381: Pq-X-L/MT\_A\_So interfaces**

Inputs	Outputs
<u>Each MT_CP:</u> MT_CI_Data MT_CI_iPHB MT_CI_oPHB  <u>SCC_CP:</u> SCC_CI_Data  <u>Pq-X-L_AP:</u> Pq-X-L_AI_XAT  <u>Pq-X-L_TP:</u> Pq-X-L_TI_Clock Pq-X-L_TI_FrameStart  <u>Pq-X-L/MT_A_So_MP:</u> Pq-X-L/MT_A_So_MI_Active Pq-X-L/MT_A_So_MI_SCCType Pq-X-L/MT_A_So_MI_Label[1...M] Pq-X-L/MT_A_So_MI_LSPTType[1...M] Pq-X-L/MT_A_So_MI_CoS[1...M] Pq-X-L/MT_A_So_PHB2TCMapping[1...M] Pq-X-L/MT_A_So_MI_QoSEncodingMode[1...M] Pq-X-L/MT_A_So_MI_Mode[1...M]  Pq-X-L/MT_A_So_MI_GAL_Enable[1...M]	<u>Pq-X-L_AP:</u> Pq-X-L_AI_Data Pq-X-L_AI_Clock Pq-X-L_AI_FrameStart

**Processes**

A process diagram of this function is shown in Figure 11-40.

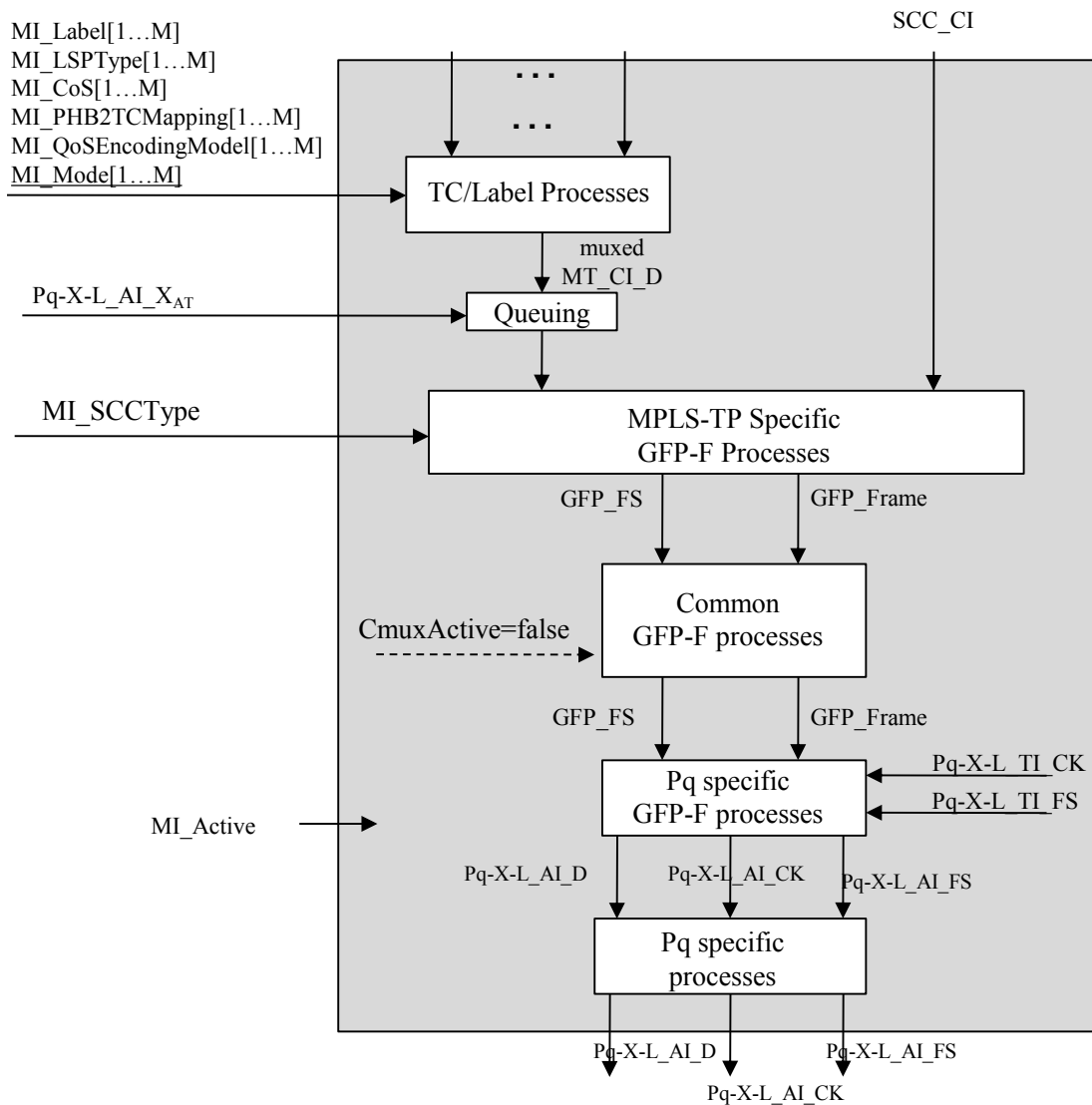


Figure 11-40/G.8121/Y.1381 – Pq-X-L/MT\_A\_So process diagram

[New: add MI\_Active]

The processes have the same definition as in 11.1.1.1.

**Defects**

None.

**Consequent actions**

None.

**Defect correlations**

None.

**Performance monitoring**

For further study.

### 11.3.2.2 LCAS-capable Pq to MPLS-TP Adaptation Sink function (Pq-X-L/MT\_A\_Sk)

This function extracts MT\_CI information from the Pq-X-L\_AI signal (q = 11s, 12s, 31s, 32e), delivering MT\_CI.

Data at the Pq-X-L\_AP is a Pq-Xv (q = 11s, 12s, 31s, 32e), having a payload as described in [ITU-T G.7043].

#### Symbol

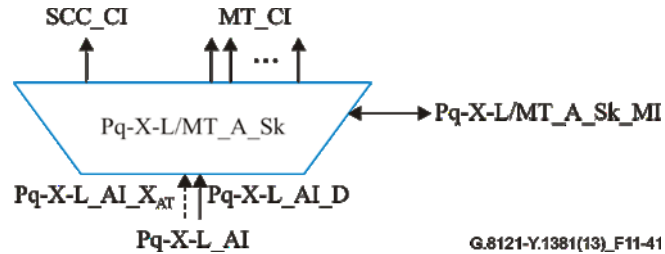


Figure 11-41/G.8121/Y.1381 – Pq-X-L/MT\_A\_Sk symbol

#### Interfaces

Table 11-16/G.8121/Y.1381: Pq-X-L/MT\_A\_Sk interfaces

Inputs	Outputs
--------	---------

<p><u>Pq-X-L_AP:</u>                  Pq-X-L_AI_Data                  Pq-X-L_AI_Clock                  Pq-X-L_AI_FrameStart                  Pq-X-L_AI_TSF                  Pq-X-L_AI_XAR</p> <p><u>Pq-X-L/MT_A_Sk_MP:</u>                  Pq-X-L/MT_A_Sk_MI_Active                  Pq-X-L/MT_A_Sk_MI_SCCType                  Pq-X-L/MT_A_Sk_MI_Label[1...M]                  Pq-X-L/MT_A_Sk_MI_LSPTYPE[1...M]                  Pq-X-L/MT_A_Sk_MI_CoS[1...M]                  Pq-X-L/MT_A_Sk_MI_TC2PHBMapping[1...M]                  Pq-X-L/MT_A_Sk_MI_QoSDecodingMode[1...M]                  Pq-X-L/MT_A_Sk_MI_Mode[1...M]</p> <p>Pq-X-L//MT_A_Sk_MI_LCK_Period[1...M]                  Pq-X-L//MT_A_Sk_MI_LCK_P[1...M]                  Pq-X-L//MT_A_Sk_MI_Admin_State                  Pq-X-L//MT_A_Sk_MI_AIS_Period[1...M]                  Pq-X-L//MT_A_Sk_MI_AIS_P[1...M]</p> <p>Pq-X-L//MT_A_Sk_MI_GAL_Enable[1...M]                  Pq-X-L/MT_A_Sk_MI_LCK_Tool[1...M]                  Pq-X-L/MT_A_Sk_MI_AIS_Tool[1...M]</p>	<p><u>Each MT_CP:</u>                  MT_CI_Data                  MT_CI_iPHB                  MT_CI_oPHB                  MT_CI_SSF                  MT_CI_LStack</p> <p><u>SCC_CP:</u>                  SCC_CI_Data                  SCC_CI_SSF</p> <p><u>Pq-X-L/MT_A_Sk_MP:</u>                  Pq-X-L/MT_A_Sk_MI_AcSL                  Pq-X-L/MT_A_Sk_MI_AcEXI                  Pq-X-L/MT_A_Sk_MI_LastInvalidUPI                  Pq-X-L/MT_A_Sk_MI_cPLM                  Pq-X-L/MT_A_Sk_MI_cLFD                  Pq-X-L/MT_A_Sk_MI_cEXM                  Pq-X-L/MT_A_Sk_MI_cUPM</p>
--	---

**Processes**

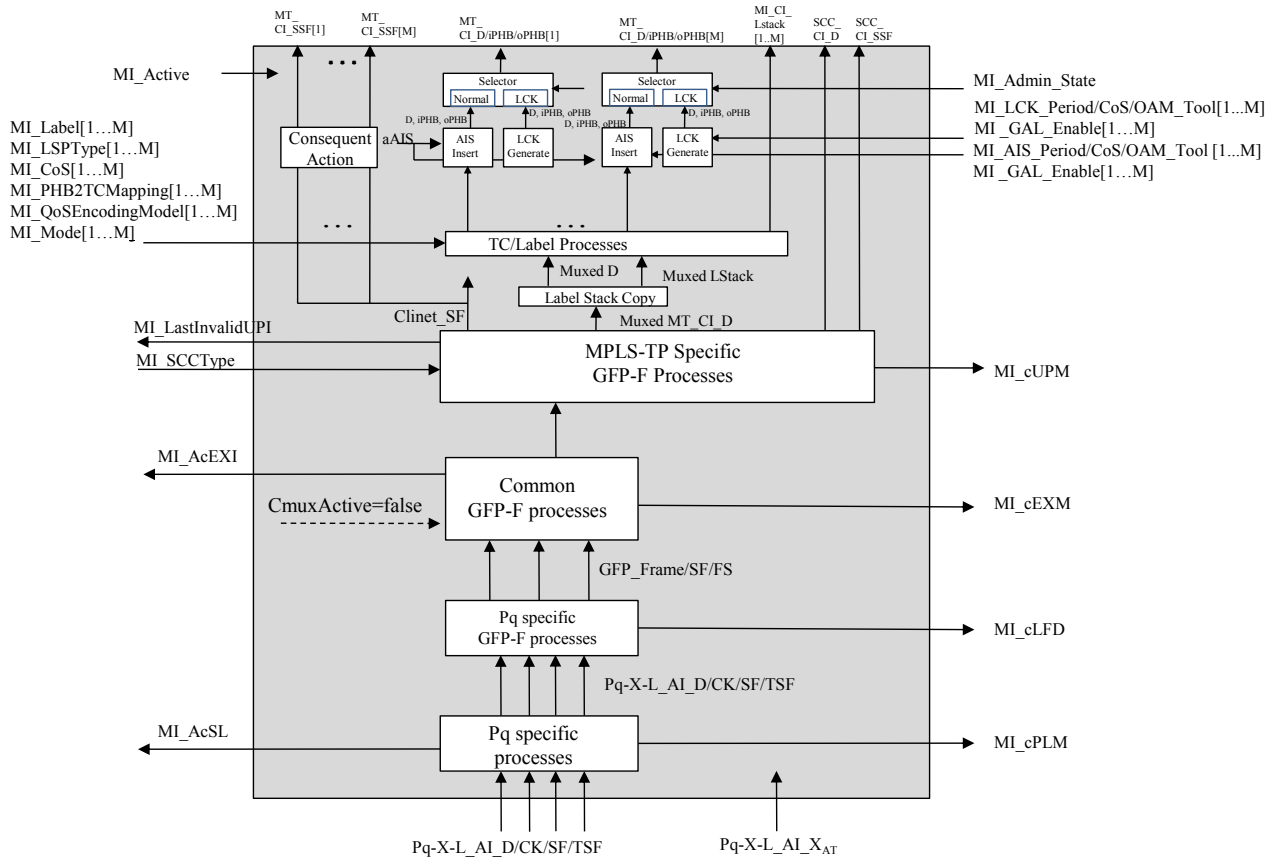


Figure 11-42/G.8121/Y.1381 – Pq-X-L/MT\_A\_Sk process diagram

[New: add MI\_Active/Remove APS, GFP\_Length]

See process diagram and process description in 11.1.1.2. The additional Pq-X-L\_AI\_XAR interface is not connected to any of the internal processes.

### Defects

dPLM – See 6.2.4.2 in [ITU-T G.806].

dLFD – See 6.2.5.2 in [ITU-T G.806].

dUPM - See 8.4.2

dEXM – See 6.2.4.4 in [ITU-T G.806].

Note: dPLM is only defined for q = 31s. dPLM is assumed to be false for q = 11s, 12s, 32e.

### Consequent actions

The function shall perform the following consequent actions:

aSSF ← AI\_TSF or dPLM or dLFD or dUPM or dEXM

aAIS ← AI\_TSF or dPLM or dLFD or dUPM or dEXM

### Defect correlations

The function shall perform the following defect correlations to determine the most probable fault cause (see 6.4/G.806). This fault cause shall be reported to the EMF.

cPLM ← dPLM and (not AI\_TSF)

cLFD ← dLFD and (not dPLM) and (not AI\_TSF)

cEXM ← dEXM and (not dPLM) and (not dLFD) and (not AI\_TSF)

cUPM ← dUPM and (not dEXM) and (not dPLM) and (not dLFD) and (not AI\_TSF)

### Performance monitoring

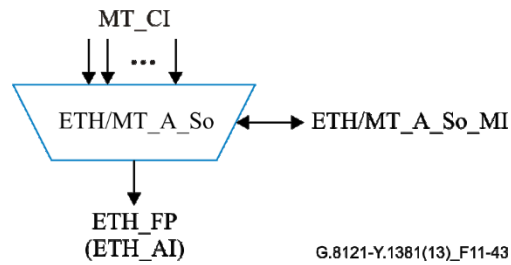
For further study.

## 11.4 Ethernet to MPLS-TP adaptation function

### 11.4.1 ETH to MPLS-TP adaptation function (ETH/MT\_A)

#### 11.4.1.1 ETH to MPLS-TP adaptation function (ETH/MT\_A)

#### Symbol



**Figure 11-43 – ETH/MT\_A\_So symbol**



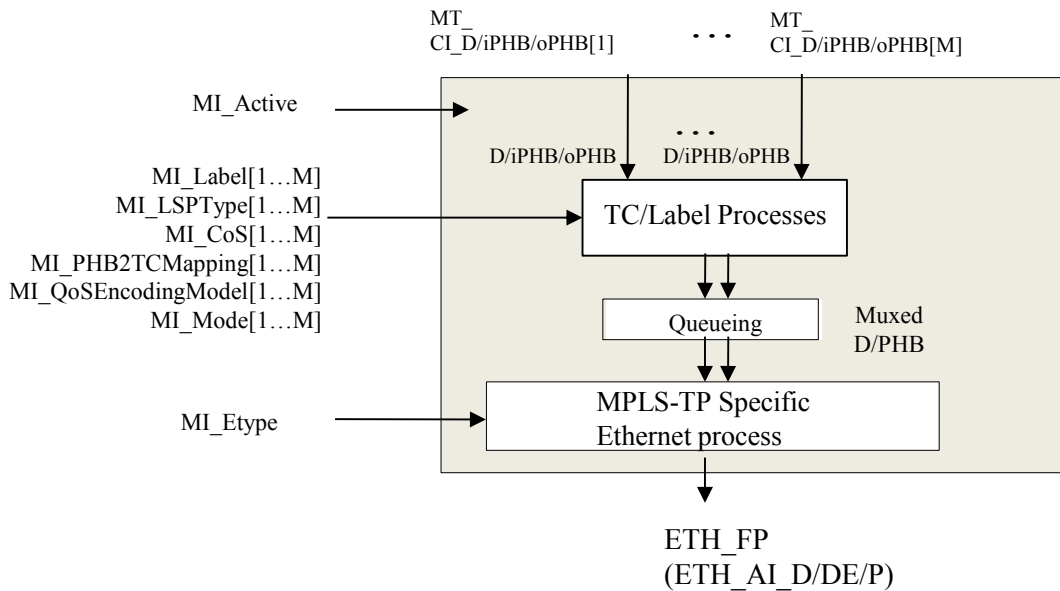
## Interfaces

**Table 11-19: ETH/MT\_A\_So interfaces**

Inputs	Outputs
<p><b>Each MT_CP:</b>            MT_CI_Data[1...M]            MT_CI_iPHB[1...M]            MT_CI_oPHB[1...M]</p> <p><b>ETH/MT_A_So_MP:</b>            ETH/MT_A_So_MI_Active            ETH/MT_A_So_MI_Label[1...M]            ETH/MT_A_So_MI_LSPTYPE[1...M]            ETH/MT_A_So_MI_CoS[1...M]            ETH/MT_A_So_PHB2TCMapping[1...M]            ETH/MT_A_So_MI_QoSEncodingMode[1...M]            ETH/MT_A_So_MI_Mode[1...M]            ETH/MT_A_So_MI_Etype</p> <p>ETH/MT_A_So_MI_GAL_Enable[1...M]</p>	<p><b>ETYn AP:</b>            ETH_AI_Data            ETH_AI_P            ETH_AI_DE</p>

## Processes

A process diagram of this function is shown in Figure 11-44.



**Figure 11-44 – ETH/MT\_A\_So process**

[New: add MI\_Active]

– TC/Label processing

See 8.2.1

– *Queuing process:*

See 8.3.

– *MPLS-TP specific Ethernet process::*

This process inserts the Ethertype for MPLS-TP packets according to [IETF RFC 5332]

<b>Defects</b>	None.
<b>Consequent actions</b>	None.
<b>Defect correlations</b>	None.
<b>Performance monitoring</b>	For Further Study.

#### 11.4.1.2 ETH to MPLS-TP adaptation function (ETY/MT\_A)

Symbol

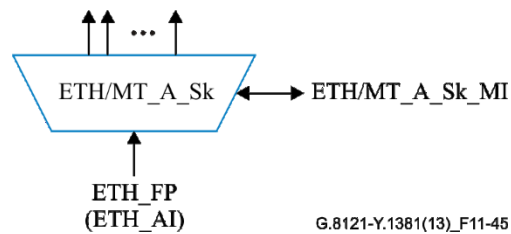


Figure 11-45 – ETH/ETH\_A\_Sk symbol

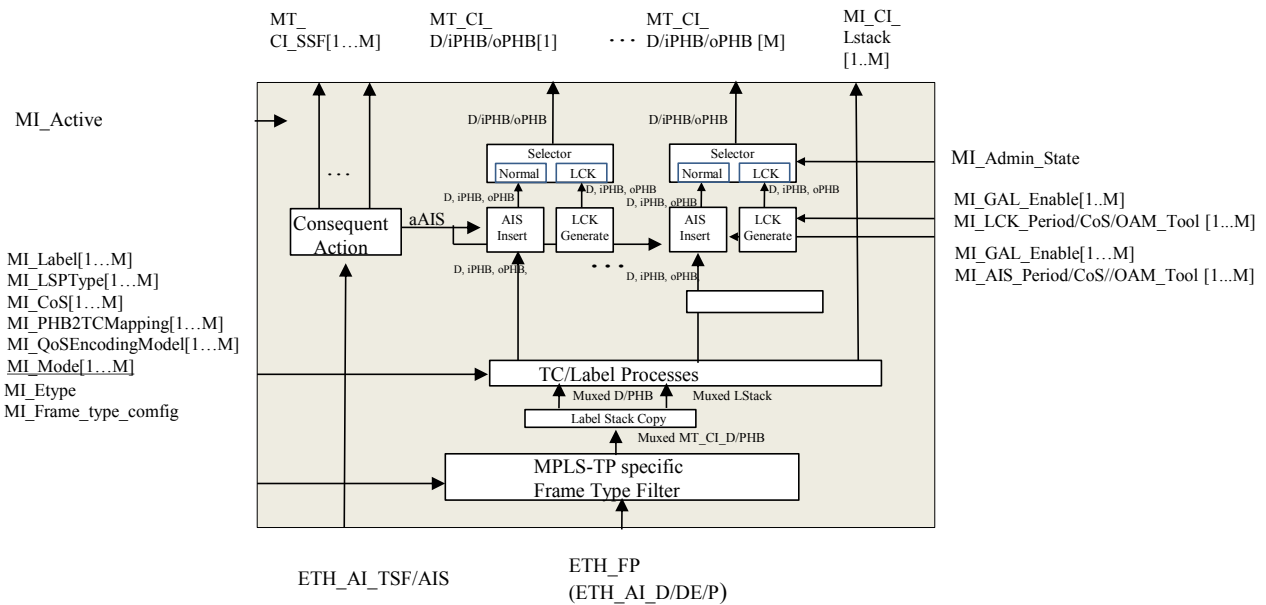
**Interfaces**

**Table 11-20: ETH/MT\_A\_Sk interfaces**

Inputs	Outputs
<p><u>ETH_AP:</u>            ETH_AI_Data            ETH_AI_P            ETH_AI_DE            ETH_AI_TSF            ETH_AI_AIS</p> <p><u>ETH/MT_A_Sk_MP:</u>            ETH/MT_A_Sk_MI_Active            ETH/MT_A_Sk_MI_Etype            ETH/MT_A_Sk_MI_Frame_Type_Config</p> <p>ETH/MT_A_Sk_MI_Label[1...M]            ETH/MT_A_Sk_MI_LSPTType[1...M]            ETH/MT_A_Sk_MI_CoS[1...M]            ETH/MT_A_Sk_MI_TC2PHBMapping[1...M]            ETH/MT_A_Sk_MI_QoSDecodingMode[1...M]            ETH/MT_A_Sk_MI_Mode[1...M]</p> <p>ETH/MT_A_Sk_MI_GAL_Enable[1...M]            ETH/MT_A_Sk_MI_Admin_State</p> <p>ETH/MT_A_Sk_MI_LCK_Period[1...M]            ETH/MT_A_Sk_MI_LCK_CoS[1...M]</p> <p>ETH/MT_A_Sk_MI_AIS_Period[1...M]            ETH/MT_A_Sk_MI_AIS_CoS[1...M]            ETH/MT_A_Sk_MI_LCK_OAM_Tool[1...M]            ETH/MT_A_Sk_MI_AIS_OAM_Tool[1...M]</p>	<p><b>Each MT_CP:</b>            MT_CI_Data[1...M]            MT_CI_iPHB[1...M]            MT_CI_oPHB[1...M]            MI_CI_Lstack[1...M]</p>

**Processes**

A process diagram of this function is shown in Figure 11-46.



**Figure 11-46 – ETYn/ETH\_A\_Sk process**

[New: add MI\_Active]

– Selector generation process:

See 8.6.1 The normal CI is blocked if Admin\_State = LOCKED.

– AIS Insert process:

See 8.6.2. There is a single AIS Insert process for each MT.

– LCK generation process:

See 8.6.3. There is a single LCK Insert process for each MT.

– TC/Label processes:

See 8.2.2.

– Label Stack Copy process:

See 8.2.3.

– MPLS-TP specific Filter process:

This process is for the reception process of the Ethertype for MPLS-TP packets according to [IETF RFC 5332].

<b>Defects</b>	None.
<b>Consequent actions</b>	FFS
<b>Defect correlations</b>	None.
<b>Performance monitoring</b>	For Further Study.

## Appendix I

### Examples of processing of packets with expired TTL

(This appendix does not form an integral part of this Recommendation)

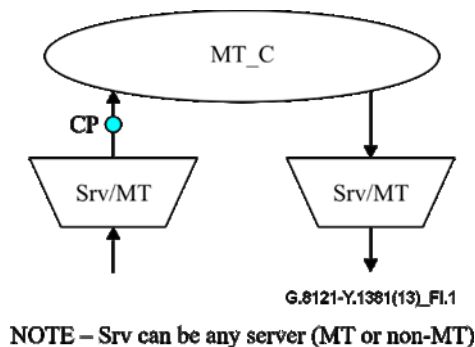
MPLS-TP packets received with an expired TTL shall not be forwarded. However MPLS-TP OAM packets received with an expired TTL can be processed and their processing can happen at different locations (i.e., from different atomic functions) within an MPLS-TP Equipment.

The proper behavior depends on the MPLS-TP connection configuration within the node. The following examples are considered and described:

- Intermediate node with no MIPs
- Intermediate node – interface MIPs
- Intermediate node – node MIP
- Terminating Node - Down MEP or node MEP
- Terminating Node - Up MEP (with interface MIP)

NOTE – As indicated in clause 9.4.2.2.2, the MI\_DS\_MP\_Type parameter should be properly configured by the EMF and not exposed to the operator as a configuration parameter of the NE Management. The examples described in this appendix provides guidelines on how the EMF can properly configure the MI\_DS\_MP\_Type.

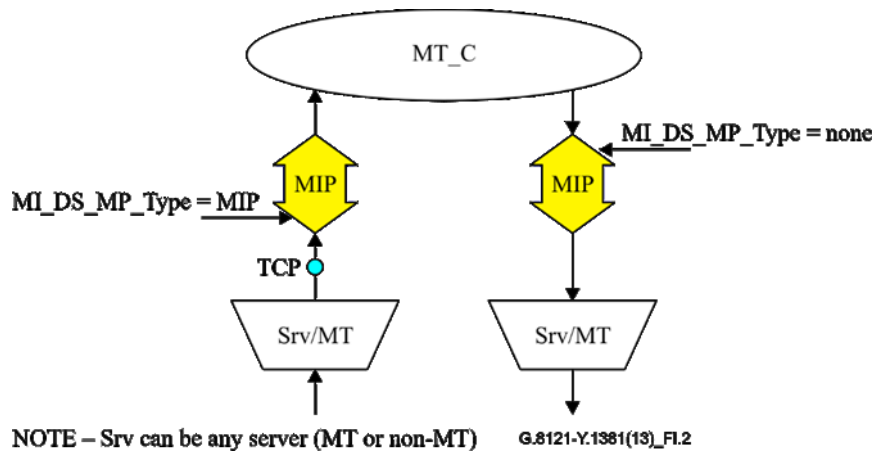
Figure I.1 describes the behavior of an intermediate node with no MIPs using the atomic functions defined in this Recommendation:



**Figure I.1 – Intermediate node with no MIPs**

The Server/MT\_A\_Sk is connected to the MT\_C via an MT\_CP. Therefore the TTL Decrement Process, as defined in clause 8.2.2, will discard all the MPLS-TP packets (user data or OAM) that are received with an expired TTL.

Figure I.2 describes the behavior of an intermediate node supporting per-interface MIPs using the atomic functions defined in this Recommendation:



**Figure I.2 – Intermediate node with per-interface MIPs**

The Server/MT\_A\_Sk is connected to ingress MIP via an MT\_TCP. Therefore the TTL Decrement Process, as defined in clause 8.2.2, will forward all the MPLS-TP packets (user data or OAM) that are received with an expired TTL to the ingress MIP.

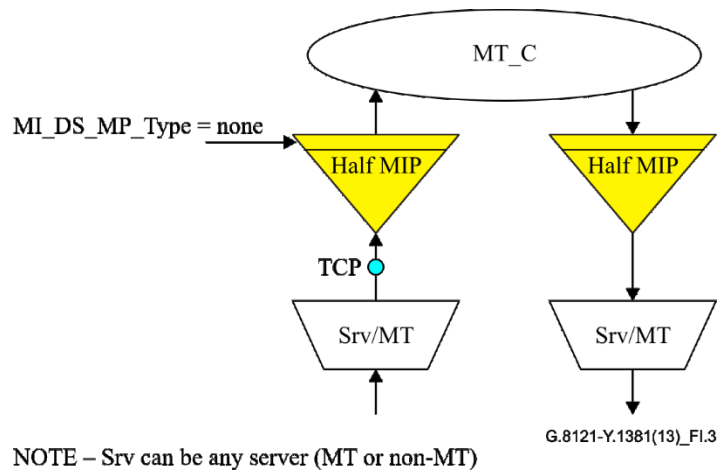
The MTDi\_TT\_Sk atomic function within the ingress MIP will process all the MPLS-TP OAM packets received with an expired TTL and which are targeted to the ingress MIP.

The TTL check process in the MTDi/MT\_A\_Sk within the ingress MIP, as defined in clause 9.4.2.2.2, is properly configured by the EMF (MI\_DS\_MP\_Type=MIP) to drop all the MPLS-TP user data packets received with an expired TTL and to forward all the MPLS-TP OAM packets received with an expired TTL together (i.e., with fate share) with all the MPLS-TP packets received with a non-expired TTL.

These packets are forwarded up to the egress MIP where the MTDi\_TT\_Sk atomic function will process all the MPLS-TP OAM packets received with an expired TTL and which are targeted to the egress MIP.

The TTL check process in the MTDi/MT\_A\_Sk within the egress MIP, as defined in clause 9.4.2.2.2, is properly configured by the EMF (MI\_DS\_MP\_Type=none) to drop all the MPLS-TP packets received with an expired TTL. Although MPLS-TP user data packets with an expired TTL will never arrive at this point, this check will ensure also that any MPLS-TP OAM packet with an expired TTL is not forwarded.

Figure I.3 describes the behavior of an intermediate node with a per-node MIP using the atomic functions defined in this Recommendation. The per-node MIP is modeled as being composed by two half-MIPs on each side of the MT\_C:



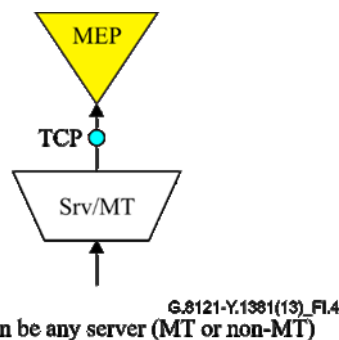
**Figure I.3 – Intermediate node with a per-node MIP**

The Server/MT\_A\_Sk is connected to ingress MIP via an MT\_TCP. Therefore the TTL Decrement Process, as defined in clause 8.2.2, will forward all the MPLS-TP packets (user data or OAM) that are received with an expired TTL to the ingress half-MIP.

The MTDi\_TT\_Sk atomic function within the ingress half-MIP will process all the MPLS-TP OAM packets received with an expired TTL and which are targeted to the node MIP.

The TTL check process in the MTDi/MT\_A\_Sk, as defined in clause 9.4.2.2.2, is properly configured by the EMF (MI\_DS\_MP\_Type=none) to drop all the MPLS-TP packets (user data or OAM) that are received with an expired TTL.

Figure I.4 describes the behavior of a terminating node with a Down MEP or a per-node MEP using the atomic functions defined in this Recommendation. These two cases are modeled in the same way:

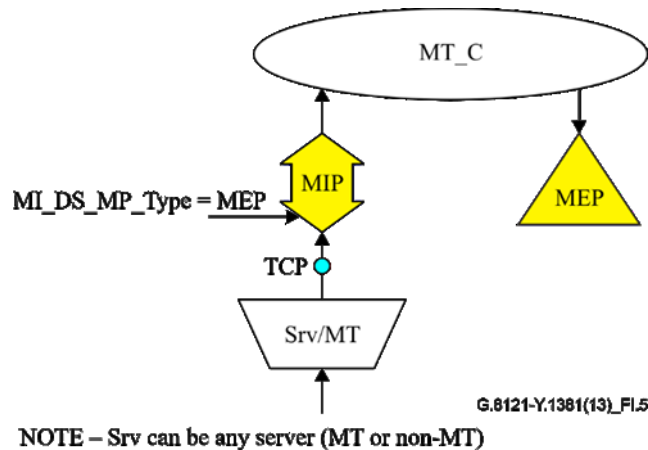


**Figure I.4 – Terminating node with a down MEP or node MEP**

The Server/MT\_A\_Sk is connected to MEP via an MT\_TCP. Therefore the TTL Decrement Process, as defined in clause 8.2.2, will forward all the MPLS-TP packets (user data or OAM) that are received with an expired TTL to the MEP.

The MEP terminates the MPLS-TP trail and processes all the MPLS-TP packets it receives regardless of whether the TTL has expired or not.

Figure I.5 describes the behavior of a terminating node with an Up MEP, and therefore a per-interface ingress MIP, using the atomic functions defined in this Recommendation:



**Figure I.5 – Terminating node with an Up MEP (and a per-interface MIP)**

The Server/MT\_A\_Sk is connected to ingress MIP via an MT\_TCP. Therefore the TTL Decrement Process, as defined in clause 8.2.2, will forward all the MPLS-TP packets (user data or OAM) that are received with an expired TTL to the ingress MIP.

The MTDi\_TT\_Sk atomic function within the ingress MIP will process all the MPLS-TP OAM packets received with an expired TTL and which are targeted to the ingress MIP.

The TTL check process in the MTDi/MT\_A\_Sk within the ingress MIP, as defined in clause 9.4.2.2.2, is properly configured by the EMF (MI\_DS\_MP\_Type=MEP) to forward all the MPLS-TP packets (user data or OAM) that are received with an expired TTL together (i.e., with fate share) with all the MPLS-TP packets received with a non-expired TTL.

These packets are forwarded up to the Up MEP that terminates the MPLS-TP trail and processes all the MPLS-TP packets it receives regardless of whether the TTL has expired or not.



## Appendix II Flow of PHB information through MEP and MIP

(This appendix does not form an integral part of this Recommendation)

This recommendation describes the various atomic functions that comprise MIPs and MEPs:

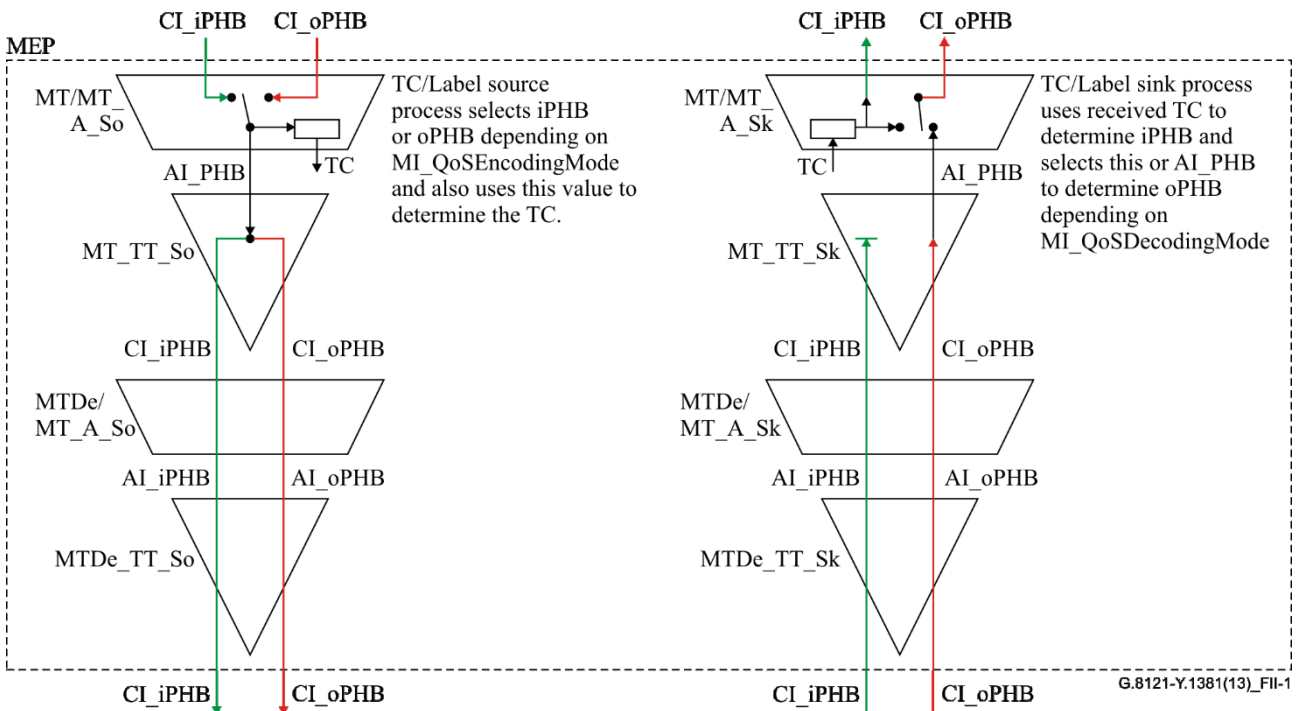
- MEP: MT/MT\_A, MT\_TT, MTDe/MT\_A, MTDe\_TT
- MIP: Two MHFs each comprising MTDi\_TT, MTDi/MT\_A

The handling of PHB values is described in clauses 8.2, 9.2, 9.3 and 9.4. The PHB information is passed between the atomic functions in Characteristic Information (CI) and Adapted Information (AI).

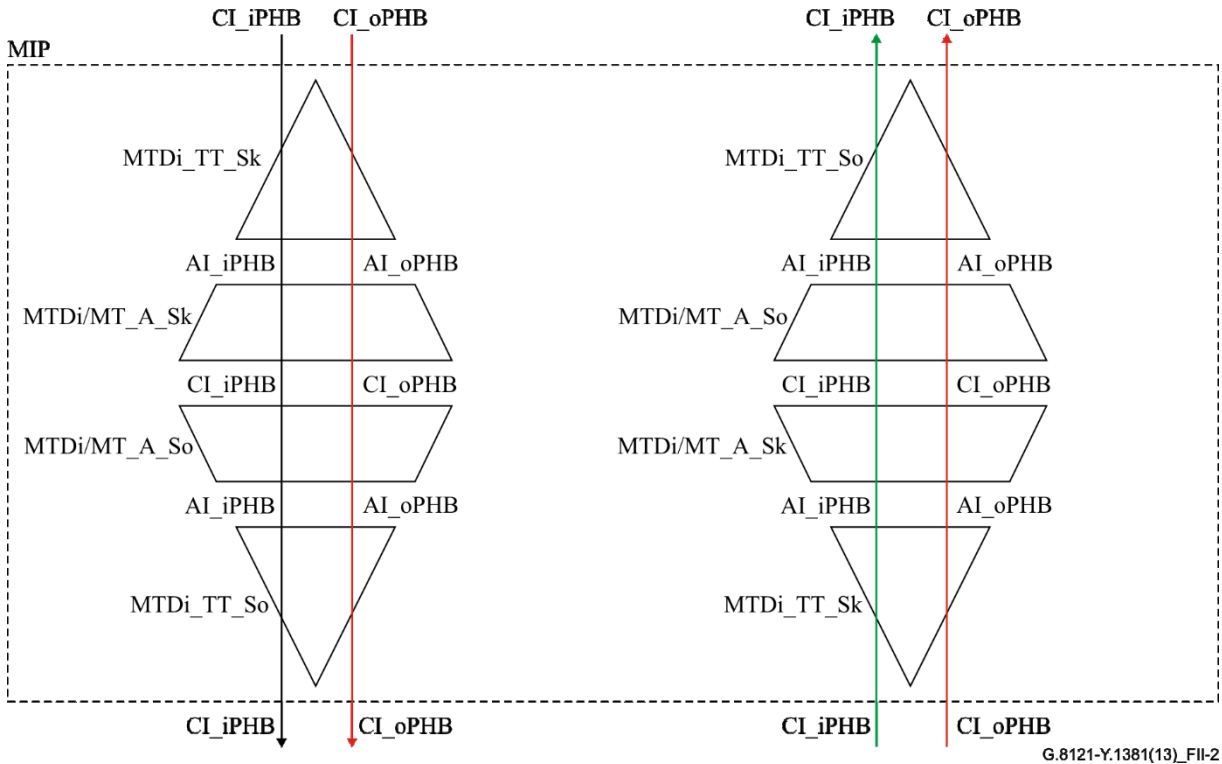
As described in Clause 10/G.8110.1, the MPLS-TP Diffserv architecture supports two models: the “Short Pipe” model, and the “Uniform” model. To support this, it is necessary in certain cases to pass two PHB values in the CI and AI, referred to as the incoming PHB (iPHB) and outgoing PHB (oPHB). In other cases, only a single PHB values needs to be passed between the atomic functions.

Figures 10-1/G.8110.1 and 10-2/G.8110.1 are the reference diagrams showing how PHB values are used in the two models. However, these do not show all of the atomic functions defined in this recommendation that comprise MEPs and MIPs. So, in particular, it is unclear at a first glance why in some cases the AI carries a single PHB value, while in other cases it carries separate iPHB and oPHB values.

The figures below show a MEP and a MIP and illustrate the flow of PHB information through them. The iPHB values are shown in green, oPHB values in red, and where only a single PHB value is used, this is shown in black.



**Figure II.1 – Flow of PHB information through a MEP**

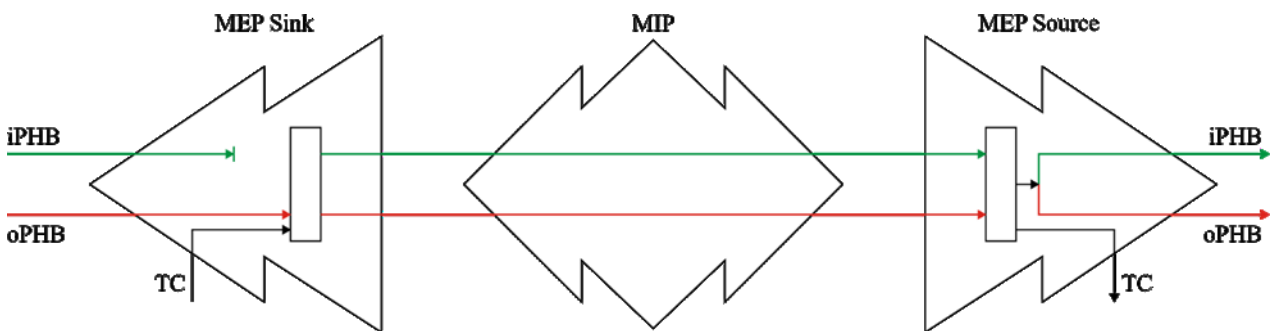


G.8121-Y.1381(13)\_FII-2

**Figure I.2 – Flow of PHB information through a MIP**

By considering a case where the sink side of one MEP is connected to the source side of another MEP, via a MIP, it becomes clear why both the iPHB and oPHB values must be passed through the MIP without modification. This is illustrated in the following figure. The same logic would apply if the MTDe\_TT and MTDe/MT\_A atomic functions were used without their associated MT\_TT and MT/MT\_A functions.

**Figure II.3 –Example showing two MEPs and a MIP**



G.8121-Y.1381(13)\_FII-3

## **Appendix III**

### **Examples of MPLS-TP Linear Protection**

The MPLS-TP linear protection switching architecture can be SNC/I and SNC/S protection, as defined in [ITU-T G.808.1]. The other architectures are for further study.

MPLS-TP subnetwork connection protection is used to protect a section of a connection (e.g., that section where two separate routes are available) within an operator's network or multiple operators' networks. Two independent subnetwork connections exist, which act as working and protection transport entities for the (protected) normal traffic signal.

Figure III.1 shows an example of the MPLS-TP SNC/I protection switching models. Protection switching is triggered by defects detected at the MPLS-TP link connection (e.g., server layer trail and server/MT adaptation function). The server layer may be MPLS-TP layer managed by another operator.

MPLS-TP SNC may be indirectly monitored by using the inherently available data from the MPLS-TP server layers. The trail termination sink of the server layer provides the TSF-based SF protection switching criteria via Server/MT\_A or MT/MT\_A. No defect detection is performed on the protected MPLS-TP layers itself.

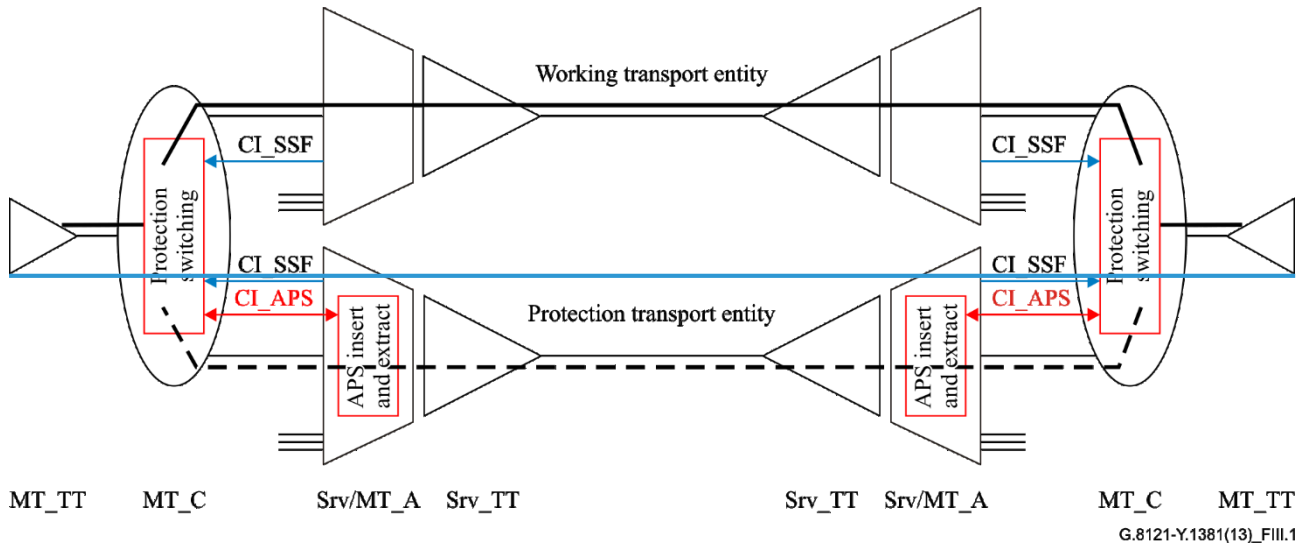
NOTE—Protection switching triggered by signal degrade is for further study.

Srv/MT\_A\_So in the protection transport entity includes the APS insert process and Srv/MT\_A\_Sk in the protection transport entity includes the APS extract process. These processes generate or process the OAM signal to indicate the CI\_APS information. The specific CI\_APS information is outside the scope of this Recommendation.

The protection switching controller process is provided in the MT connection function (MT\_C).

Within MT\_C, an MPLS-TP SNC protection switching process is instantiated to protect the MPLS-TP connection. When protection switching is configured for an MPLS-TP connection, i.e., the protected MPLS SNC, it is defined between two MT connection points (MT\_CPs). Each instantiated SNC protection switching process determines the specific output MT\_CP over which the protected MT\_CI is transferred.

As described in clause 9.1 of this Recommendation, the detail of the protection switching process in MT\_C is for further study.

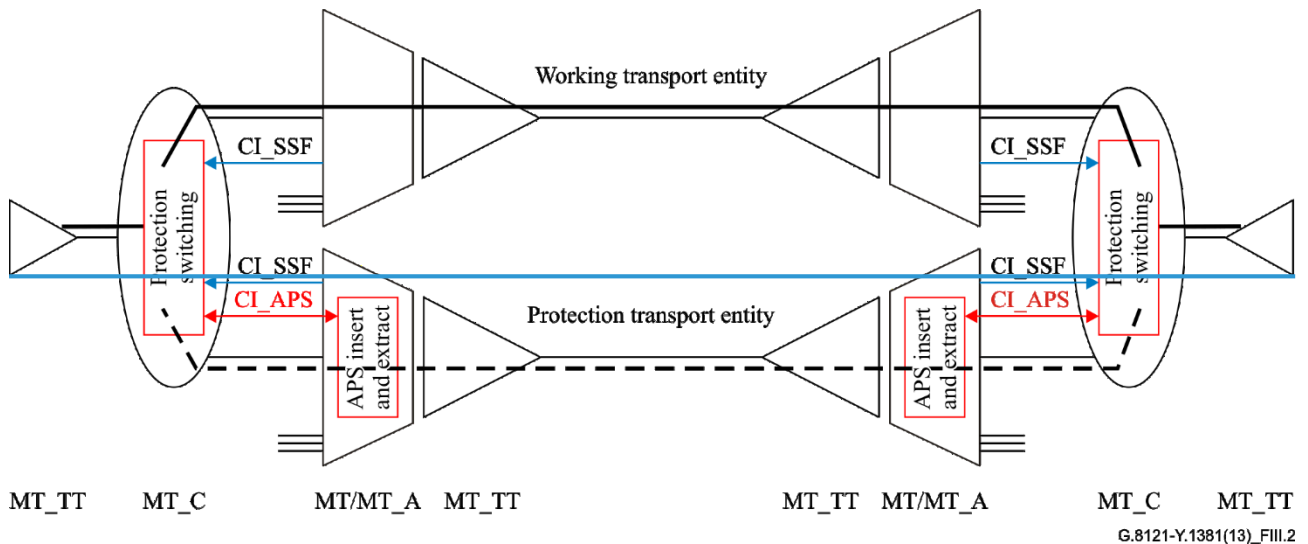


**Figure III.1—MPLS-TP SNC/I protection switching architecture**

Figure III.2\_1 shows an example of the MPLS-TP SNC/S protection switching models. These subnetwork connections provide sublayer monitoring for a segment of a given LSP, as described in clause 8.2.5 of [ITU-T G.8110.1].

MT/MT\_A So in the protection transport entity includes the APS insert process and MT/MT\_A\_Sk in the protection transport entity includes the APS extract process. These processes generate or process the OAM signal to indicate the CI\_APS information. The specific CI\_APS information is outside the scope of this Recommendation.

The protection switching controller process is provided in the MT connection function (MT\_C). The functionality in MT\_C provides the same as described for SNC/I above.



**Figure III.21—MPLS-TP SNC/S protection switching architecture**

## **Bibliography**

- [ITU-T b-G.8151] Recommendation ITU-T G.8151/Y.1374 (2012), *Management aspects of the MPLS-TP network element*
- [IETF b-RFC 6378] IETF RFC 6378 *MPLS Transport Profile (MPLS-TP) Linear Protection*.
-