

Question(s): 1/15

Geneva, 14-25 February 2011

TEMPORARY DOCUMENT

Source: Editor G.phnt

Title: Draft Recommendation G.phnt "Protocol for identifying home network topology"

Based on contributions C-921 and C-922 to the June 2010 ITU-T Study Group 15 meeting, subsequent comments received, and the November 2010 Rapporteur's meeting of Question 1/15, the following Draft Recommendation G.phnt "Protocol for identifying home network topology" is prepared for review and comment. Note, the original working title was G.cmhn, "Configuration Management for IP home network".

Protocol for identifying home network topology

Summary

Based on G.9971, this recommendation specifies the configuration management protocol, which is described in TTC JJ-300.00. This protocol is used to manage devices in IP Home Network for the purpose of showing the Layer 2 home network topology to the users.

<Mandatory material>

Keywords

IP, Ethernet, home network, Access Gateway, LLDP, UPnP, UDA, protocol, management, topology

<Optional>

Introduction

<Optional - This clause should appear only if it contains information different from Scope and Summary>

1 Scope

Recently, various kinds of IP Terminal devices, such as PCs, digital TVs, gaming devices, and portable music devices, are being connected to the IP home network. Moreover, their number is also

Contact:	Yoshiyuki Mihara NTT Japan	Tel : +81-46-859-2788 Fax : +81-46-855-1282: Email: mihara.yoshiyuki@lab.ntt.co.jp
-----------------	----------------------------------	--

Contact:	Tatsuhiko Yoshida NTT Japan	Tel: +81-45-826-6480 Fax: +81-45-826-6055 Email: t.yoshida@ntt-at.co.jp
-----------------	-----------------------------------	---

Attention: This is not a publication made available to the public, but an **internal ITU-T Document** intended only for use by the Member States of ITU, by ITU-T Sector Members and Associates, and their respective staff and collaborators in their ITU related work. It shall not be made available to, and used by, any other persons or entities without the prior written consent of ITU-T.

Comment [JAJ1]: Based on TD 488 WP1 (1)

increasing. Moreover, the kinds of transmission media (PLC, wireless, UTP, etc.) used to connect each IP Terminal are also becoming more varied. Under such circumstances, most users cannot troubleshoot the IP home network by themselves if network services are not provided properly. It is desired to introduce simple and easy IP home network management that can localize the fault in each device and network as well as to recover from troubles.

G.9971 “Requirements of transport functions in IP home network” describes three kinds of management requirements for the IP home network: configuration management, fault management, and performance management. Based on G.9971, this recommendation specifies the configuration management protocol, which is described in TTC JJ-300.00. This protocol is used to manage devices in IP Home Network for the purpose of showing the L2 home network topology to the users. BBF TR-069 specifies requirements for remote management of devices within the home, called CPE WAN Management Protocol. On the other hand, this recommendation addresses network topology management within the home network only (behind the AGW). Although it may be necessary to study the interaction between this management protocol and CPE WAN Management Protocol in future, it is out of scope in this recommendation.

~~This protocol is used to manage devices in IP Home Network for the purpose of showing the L2 home network topology to the users. Note that this recommendation addresses only the protocol to manage the IP home network within the home. Although it may be necessary to study the interaction between this management protocol and CPE WAN Management Protocol in future, it is out of scope in this recommendation.~~

2 References

The following ITU-T Recommendations and other references contain provisions, which, through reference in this text, constitute provisions of this Recommendation. At the time of publication, the editions indicated were valid. All Recommendations and other references are subject to revision; users of this Recommendation are therefore encouraged to investigate the possibility of applying the most recent edition of the Recommendations and other references listed below. A list of the currently valid ITU-T Recommendations is regularly published.

The reference to a document within this Recommendation does not give it, as a stand-alone document, the status of a Recommendation.

[1] ITU-T Rec. G.9970, Generic home network transport architecture, 2009

[2] ITU-T Rec. G.9971, Requirements of transport functions in IP home network, 2010

~~[3] ITU-T Rec. G.9980, Remote management of CPE over broadband networks - CPE WAN Management Protocol (CWMP), 2011~~

~~[Editor note: G.9980 was consented by WP 1/15 in October 2010 and entered Last Call review at that time. The status of this reference will be tracked and updated as this document develops.]~~

[43] TTC JJ-300.00, HTIP: Home-network Topology Identifying Protocol, August 2010

[54] ISO/IEC 29341-1, Information technology - UPnP Device Architecture - Part 1: UPnP Device Architecture Version 1.0, Edition 1.0 2008

[65] IEEE: “802.1D, IEEE Standard for Local and metropolitan area networks, Media Access Control (MAC) Bridges”, 2004

[76] IEEE: “802.3-2008, Part 3: Carrier sense multiple access with Collision Detection (CSMA/CD) Access Method and Physical Layer Specifications”, December 2008.

[87] IEEE: “802.1AB-2009: Local and Metropolitan Area Networks - Station and Media Access Control Connectivity Discovery”, September 2009.

[98] Internet Engineering Task Force (IETF) RFC 792, “INTERNET CONTROL MESSAGE PROTOCOL”, September 1981.

Comment [JAJ2]: TD 488 WP1 (3)

3 Definitions

3.1 Terms defined elsewhere:

None

3.2 Terms defined in this Recommendation

None

4 Abbreviations and acronyms

AGW: Access Gateway

DDD: Device Description Document

ICMP: Internet Control Message Protocol

IP: Internet Protocol

LA: Local Agent

LAN: Local Area Network

LLDP: Link Layer Discovery Protocol

LLDPDU: LLDP Data Unit

LM: Local Manager

L2: Layer 2

L3: Layer 3

MAC: Media Access Control

MIB: Management Information Base

NW: Network

OUI: Organizationally Unique Identifier

TLV: Type, Length, Value

TTL: Time to Live

UDA: UPnP Device Architecture

UTP: Unshielded Twisted Pair

UPnP: Universal Plug and Play

WAN: Wide Area Network

5 Conventions

In this recommendation:

The keyword “**must**” implies that it is strictly required to claim conformance.

The keyword “**should**” implies that it is recommended for performance improvement etc. although it is not absolutely required to claim conformance.

The keyword “**may**” implies that it is not required to claim conformance.

6 The applied area of the protocol for identifying home network topology

Figure 6-1 shows the Home Network area in which the protocol specified by this recommendation is applied. Both Access Network and IP / non-IP Home Network behind IP Terminal are out of scope. Moreover, IP Home Network which is directly connected from Access Network without AGW is also out of scope.

The target Home Network is composed of IP Terminal, Ethernet Bridge, and AGW, where one or more IP Terminals can be connected to IP Home Network, while zero or more Ethernet Bridges can reside within IP Home Network. AGW has two kinds of functions, Home Network side and Access Network side, while it contains L2 and/or L3 functions. However, this recommendation only covers the configuration management on Home Network side functions of AGW. Moreover, even if AGW contains L3 function such as IP routing function, this recommendation only covers the functions necessary for identifying L2 home network topology. Moreover, it is assumed that the broadcast protocol in data link layer is utilized for this protocol.

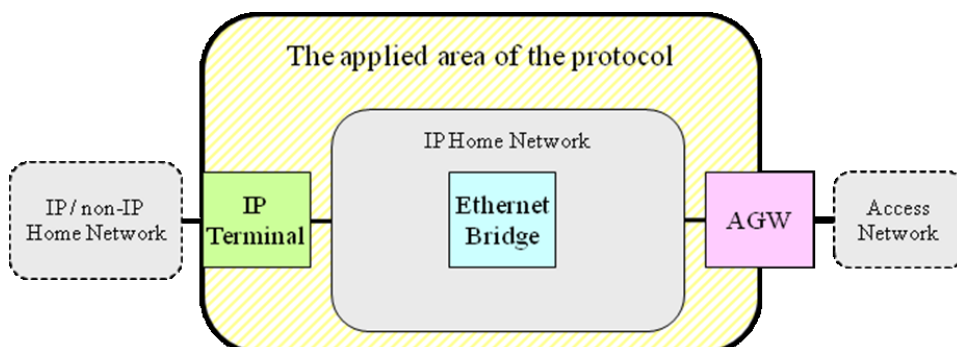

Figure 6-1 The applied area of the protocol

7 Functional requirements of the protocol for identifying home network topology

The protocol is mainly used for identifying the home network topology. It is also used for checking the connectivity between Local Manager and Local Agent, the definitions of which are described in clause 11.1 of G.9971. This recommendation specifies the protocol that meets some of the requirements listed in clause 11.3 of G.9971. The functional requirements as well as their relationship with those in G.9971 are given below. Moreover, Figure 8-1 will be also helpful to understand these requirements.

R1 (based on R11-C1 and R11-C2 in G.9971): The Local L3 Agent must be able to acquire the IP and MAC addresses of the device where the Local L3 Agent resides. The Local L3 Agent must

also be able to transmit the IP and MAC addresses to the Local Manager in the manner described in clause 8.2.

R2 (based on R11-C3 in G.9971): The Local L2 Agent must be able to acquire the MAC forwarding table retained by the device where the Local L2 Agent resides. The Local L2 Agent must also be able to transmit the MAC forwarding table to the Local Manager in the manner described in clause 8.3.

R3 (based on R11-C4 in G.9971): The Local L3 Agent must be able to acquire and transmit its device information to the Local Manager in the manner described in clause 8.2.

R4 (based on R11-C5 in G.9971): The Local L2 Agent must be able to acquire and transmit its device information to the Local Manager in the manner described in clause 8.3.

R5 (based on R11-L2 in G.9971): The Local L3 Agent should be able to respond to a connectivity check command from the Local Manager in the manner described in clause 9.1.

R6 (based on R11-L2 in G.9971): The Local L2 Agent should be able to send packets periodically to the Local Manager for checking connectivity in the manner described in clause 9.2.

8 The protocol for identifying home network topology

This clause describes the interaction between the Local Manager and the Local L3 Agent as well as the Local Manager and the Local L2 Agent.

Management information to identify the IP home network topology falls into two areas: device information and MAC forwarding table information. One example of device information is device category, such as Ethernet Bridge or PC. Device information resides in the Local L3 Agent or the Local L2 Agent, while the MAC forwarding table information resides in the Local L2 Agent of the Ethernet Bridge or the AGW.

Management information can be retrieved by the Local Manager, which can reside in any device in IP Home Network, according to the last paragraph of clause 11.1 of G.9971. Figure 8-1 shows a typical case that the Local Manager resides in AGW. AGW has both the Local L2 and L3 Agents, while Ethernet Bridge and IP Terminal have the Local L2 Agent and the Local L3 Agent respectively. The Local L3 Agent of IP Terminal sends device information by using UDA, while the Local L2 Agent of Ethernet Bridge sends both device information and MAC forwarding table information by using LLDP. Note that the Local L2 and L3 Agents of AGW locally send device information to the Local Manager. The Local Manager can identify the IP Home Network topology by analyzing the collection of this management information. By utilizing this IP Home Network topology information, some applications can perform fault localization in response to the failure of network services to be provided properly.

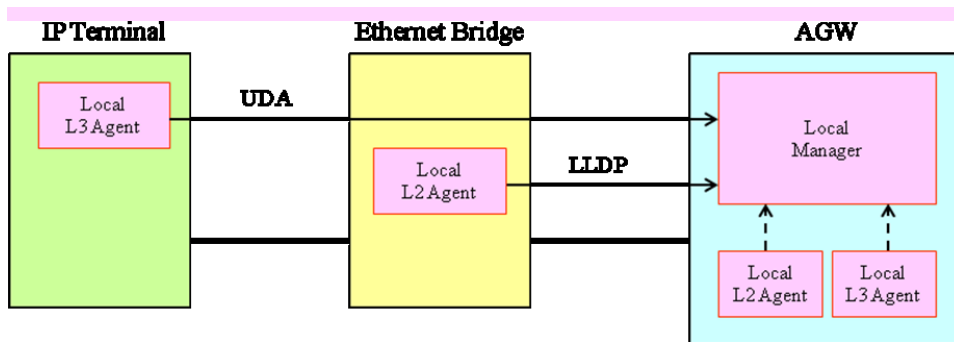

Figure 8-1 The protocol for identifying home network topology

Comment [JAJ3]: TD 488 WP1 (2)

8 The protocol for identifying home network topology

This clause describes the interaction between the Local Manager and the Local L3 Agent as well as the Local Manager and the Local L2 Agent.

Management information to identify the IP home network topology falls into two areas: device information and MAC forwarding table information. One example of device information is device category, such as Ethernet Bridge or PC. Device information resides in the Local L3 Agent or the Local L2 Agent, while the MAC forwarding table information resides in the Local L2 Agent of the Ethernet Bridge or the AGW.

Management information can be retrieved by the Local Manager, which can reside in any device in IP Home Network, according to the last paragraph of clause 11.1 of G.9971. Figure 8-1 shows a typical case that the Local Manager resides in AGW. AGW has both the Local L2 and L3 Agents, while Ethernet Bridge and IP Terminal have the Local L2 Agent and the Local L3 Agent respectively. The Local L3 Agent of IP Terminal sends device information by using UPnP UDA, while the Local L2 Agent of Ethernet Bridge sends both device information and MAC forwarding table information by using LLDP. Note that the Local L2 and L3 Agents of AGW locally send device information to the Local Manager. The Local Manager can identify the IP Home Network topology by analyzing the collection of this management information. By utilizing this IP Home Network topology information, some applications can perform fault localization in response to the failure of network services to be provided properly.

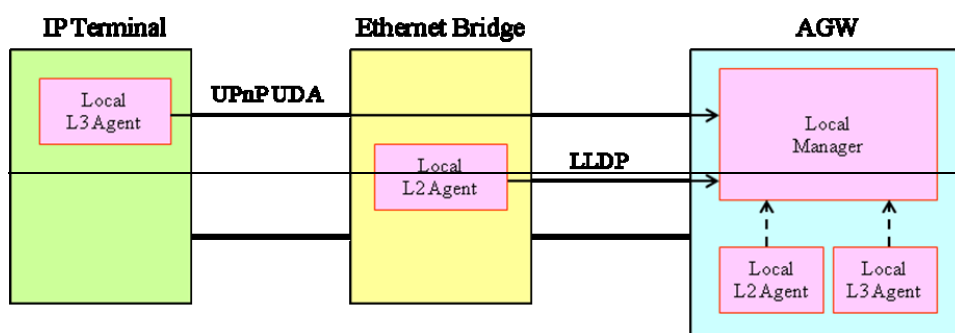

Figure 8-1 The protocols for identifying home network topology

8.1 Management information

Each Local Agent of the device, such as IP Terminal, Ethernet Bridge or AGW, manages device information representing the device. It consists of at least the following four kinds of management information. String length of the management information is described in clause 6.1 of TTC JJ-300.00.

- Device category: It represents the category of each device, such as TV or DVD recorder.
- Manufacturer code: It represents the company that produced the device. It is company ID (OUI code) registered by IEEE.
- Model name: It represents the device's brand or series name assigned by the manufacturer.
- Model number: It represents the device's model number assigned by the manufacturer.

MAC forwarding table information is specified for Ethernet Bridge. It represents the pair of Ethernet Bridge port and one or more MAC addresses of devices, such as IP Terminal or Ethernet Bridge or AGW, connected to this port.

8.2 Interaction between the Local Manager and the Local L3 Agent

The Local L3 Agent must send device information to the Local Manager by utilising the UPnP controlled device function described in ISO/IEC 29341-1 (UDA). Note that it uses the “Basic Device Information” part of the DDD message per the Local L3 Agent. The detailed methods and timing for the Local Manager to retrieve device information from the Local L3 Agent must comply with clause 2 “Description” in UDA, while that for IPv6 must comply with Annex A in UDA. Each element of “Basic Device Information”, such as device category, manufacturer code, model name and model number, must comply with TTC JJ-300.00. Moreover, detailed specifications of each element, such as the name space and the character length, must follow clause 6.2 in TTC JJ-300.00.

When the Local L3 Agent transmits the device information to the Local Manager, the IP and MAC addresses are set in the packet header. Therefore, the IP and MAC addresses can be transmitted to the Local Manager.

8.3 Interaction between the Local Manager and the Local L2 Agent

The Local L2 Agent must send device information and MAC forwarding table information to the Local Manager by utilising LLDP. Both types of information are broadcast from all ports via the LLDP Agent specified in IEEE 802.1AB. According to IEEE 802.1AB, the Local L2 Agent hands both types of information to the LLDP Agent, which broadcasts it from all managed ports after attaching the device MAC address. The detailed mechanism must comply with the second paragraph in clause 6.2 of TTC JJ-300.00.

The Local L2 Agent must manage the device information, MAC forwarding table information of the device on which it resides and the Chassis ID identifying the Local L2 Agent.. Moreover, the Local L2 Agent may manage the list of its LLDP Agents’ MAC addresses. The detailed mechanism to specify the Chassis ID is out of scope of this document.

The Local L2 Agent sends this management information periodically or when it is updated. The detailed specifications for timing or methods must comply with IEEE 802.1AB.

Figure 8-2 shows the LLDP Data Unit (LLDPDU) frame format used by the Local L2 Agent. The LLDPDU header consists of the destination MAC address, the source MAC address and the LLDP Ethernet type. The source MAC address must be one of the MAC addresses managed by the LLDP Agent, while the Ethernet type for LLDP must be 88-CC. According to TTC JJ-300.00, the destination MAC address must be set to FF-FF-FF-FF-FF-FF for broadcast. Each Ethernet Bridge that receives the LLDPDU must handle it according to IEEE 802.1D.

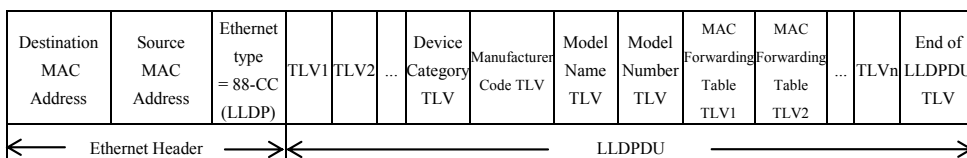

Figure 8-2 LLDPDU format

The four TLVs (TLV type=0 - 3) that IEEE 802.1AB specifies as mandatory must be contained in the LLDPDU: TLV type=0 represents “End Of LLDPDU TLV”; TLV type=1 represents “Chassis ID TLV”, TLV type=2 represents “Port ID TLV”, TLV type=3 represents “TTL TLV”. Note that the detailed specifications must comply with clause 6.3.1 in TTC JJ-300.00.

Device information and MAC forwarding table information must be sent in TLV format with extended TLV fields.. Detailed fields and values are provided in Annex A.

9 Connectivity check between the Local Manager and the Local Agents

The connectivity checks between the Local Manager and the Local Agents are executed in L2 and L3. The former is described in clause 9.1, while the latter is described in clause 9.2.

9.1 Connectivity check between the Local Manager and the Local L3 Agent

Two connectivity checks are possible in response to a fault. One is that the Local Manager re-tries to retrieve device information from the Local L3 Agent (the number of re-tries is out of scope of this Recommendation). The other is that Local Manager sends an ICMP echo request message to the Local L3 Agent and receives an ICMP echo reply message. The former can be realized by referring to clause 8.2 in this recommendation. The detailed specifications of the latter must comply with clause 7.1 in TTC JJ-300.00.

9.2 Connectivity check between the Local Manager and the Local L2 Agent

The Local Manager can keep the Chassis ID as well as TTL by interacting with the Local L2 Agent as described in clause 8.3. Therefore, the Local Manager can perform the connectivity check by checking whether or not the next LLDPDU comes after the previous one within the TTL period. The detailed specifications must comply with clause 7.2 in TTC JJ-300.00.

Annex A : Detailed fields and values of TLVs

This annex is extracted from TTC (Japan) JJ-300.00 *Home-network Topology Identifying Protocol* (HTIP).

As shown in Figure 1/Annex A, the extension of TLV fields is accomplished by setting TLV type = 127 in TLV header in accordance with IEEE 802.1AB. Moreover, TLV information string must contain TTC OUI = E0-27-1A as well as TTC subtype, which is specified in Table 6-3 of TTC JJ-300.00. The TLV Data represents device information in the case of TTC subtype = 1, while the TLV Data represents MAC forwarding table information in the case of TTC subtype = 2

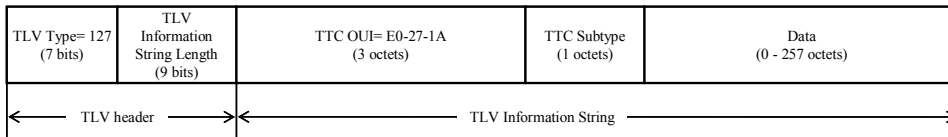

Figure 1/Annex A TLV format for device and MAC forwarding table information

In accordance with clause 6.3.2 of TTC JJ-300.00, Figure 2/Annex A shows data part of device information, which consists of device information ID, string length, and device information data. Device information IDs represent device category, manufacturer code, model name, and model number. Device information data represents the value of device information for each device. The detailed specifications of device information IDs and device information data must comply with clause 6.3.2 in TTC JJ-300.00.



Figure 2/Annex A Data format in TLV for device information

In accordance with clause 6.3.3 of TTC JJ-300.00, Figure 3/Annex A shows data part of MAC forwarding table information, which consists of kind of interface, port number, the number of MAC addresses connected to the port, and MAC addresses, including each string length. Their detailed specifications must comply with clause 6.3.3 in TTC JJ-300.00.

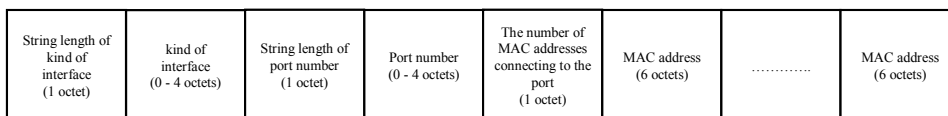

Figure 3/Annex A Data format in TLV for MAC forwarding table information

Bibliography

[b-BBF TR-069] Broadband Forum Technical Report TR 069 Amendment 2 (December 2007),
CPE WAN management protocol (CWMP)

Comment [JAJ4]: TD 488 WP1 (3)

Formatted: Left