

TR-423
PON PMD Layer Conformance Test Plan

Issue: 2
Issue Date: October 2019

Notice

The Broadband Forum is a non-profit corporation organized to create guidelines for broadband network system development and deployment. This Technical Report has been approved by members of the Forum. This Technical Report is subject to change. This Technical Report is copyrighted by the Broadband Forum, and all rights are reserved. Portions of this Technical Report may be copyrighted by Broadband Forum members.

Intellectual Property

Recipients of this Technical Report are requested to submit, with their comments, notification of any relevant patent claims or other intellectual property rights of which they may be aware that might be infringed by any implementation of this Technical Report, or use of any software code normatively referenced in this Technical Report, and to provide supporting documentation.

Terms of Use

1. License

Broadband Forum hereby grants you the right, without charge, on a perpetual, non-exclusive and worldwide basis, to utilize the Technical Report for the purpose of developing, making, having made, using, marketing, importing, offering to sell or license, and selling or licensing, and to otherwise distribute, products complying with the Technical Report, in all cases subject to the conditions set forth in this notice and any relevant patent and other intellectual property rights of third parties (which may include members of Broadband Forum). This license grant does not include the right to sublicense, modify or create derivative works based upon the Technical Report except to the extent this Technical Report includes text implementable in computer code, in which case your right under this License to create and modify derivative works is limited to modifying and creating derivative works of such code. For the avoidance of doubt, except as qualified by the preceding sentence, products implementing this Technical Report are not deemed to be derivative works of the Technical Report.

2. NO WARRANTIES

THIS Technical Report IS BEING OFFERED WITHOUT ANY WARRANTY WHATSOEVER, AND IN PARTICULAR, ANY WARRANTY OF NONINFRINGEMENT IS EXPRESSLY DISCLAIMED. ANY USE OF THIS Technical Report SHALL BE MADE ENTIRELY AT THE IMPLEMENTER'S OWN RISK, AND NEITHER THE BROADBAND FORUM, NOR ANY OF ITS MEMBERS OR SUBMITTERS, SHALL HAVE ANY LIABILITY WHATSOEVER TO ANY IMPLEMENTER OR THIRD PARTY FOR ANY DAMAGES OF ANY NATURE WHATSOEVER, DIRECTLY OR INDIRECTLY, ARISING FROM THE USE OF THIS Technical Report.

3. THIRD PARTY RIGHTS

Without limiting the generality of Section 2 above, BROADBAND FORUM ASSUMES NO RESPONSIBILITY TO COMPILE, CONFIRM, UPDATE OR MAKE PUBLIC ANY THIRD PARTY ASSERTIONS OF PATENT OR OTHER INTELLECTUAL PROPERTY RIGHTS THAT MIGHT NOW OR IN THE FUTURE BE INFRINGED BY AN IMPLEMENTATION OF THE Technical Report IN ITS CURRENT, OR IN ANY FUTURE FORM. IF ANY SUCH RIGHTS ARE DESCRIBED ON THE Technical Report, BROADBAND FORUM TAKES NO POSITION AS TO THE VALIDITY OR INVALIDITY OF SUCH ASSERTIONS, OR THAT ALL SUCH ASSERTIONS THAT HAVE OR MAY BE MADE ARE SO LISTED.

The text of this notice must be included in all copies of this Technical Report.

Issue History

Issue Number	Approval Date	Publication Date	Issue Editor	Changes
1	Jan 2019	Jan 2019	Hal Roberts, Calix	Original
2	25 October 2019	25 October 2019	Hal Roberts, Calix	Second issue of TR-423

Comments or questions about this Broadband Forum Technical Report should be directed to info@broadband-forum.org.

Editor: Hal Roberts, Calix

Work Area Director(s): Marta Seda, Calix

Project Stream Leader(s): Vincent Buchoux, LAN

Table of Contents

1 Executive Summary7

2 Purpose and Scope7

 2.1 Purpose.....7

 2.2 Scope.....7

3 References and Terminology8

 3.1 Conventions.....8

 3.2 References8

 3.3 Definitions.....9

 3.4 Abbreviations9

4 Technical Report Impact 11

 4.1 Energy Efficiency.....11

 4.2 Security11

 4.3 Privacy11

5 Test Configuration and Equipment 12

 5.1 Setup for MSE, OOC and OOB Tests.....12

 5.2 Setup for Extinction Ratio and Transmit Eye Measurements13

 5.2.1 Reference receiver definition14

6 Test Case Summary..... 14

 6.1 General14

 6.2 PMD Layer Tests14

7 ONU PMD Layer Tests..... 16

 7.1 NG-PON2 Specific ONU PMD Layer Tests.....16

 7.1.1 ONU Short Term Spectral Excursion (MSE Compliance).....16

 7.1.2 ONU Out of Channel Power Spectral Density Compliance – OOC PSD.....19

 7.1.3 ONU Out of Band Power Spectral Density Compliance – OOB PSD.....20

 7.1.4 ONU Transmitter Tuning Time.....20

 7.1.5 ONU Receiver Tuning Time.....23

 7.1.6 ONU Maximum Upstream Optical PSD when not Enabled (WNE-PSD).....24

 7.1.7 ONU Optical Path Penalty (OPP).....26

 7.2 General 10G-PON ONU PMD Layer Tests.....26

 7.2.1 ONU Transmit Power26

 7.2.2 ONU Extinction Ratio28

 7.2.3 ONU Transmit optical waveform (transmit eye)30

 7.2.4 ONU Receive Sensitivity32

 7.2.5 Central ONU Wavelength Parameters Tests35

 7.2.6 ONU Filtering.....36

 7.2.7 ONU Receive Overload38

 7.2.8 ONU Side Mode Suppression Ratio Parameter Tests.....39

 7.2.9 ONU - Physical layer overhead time and launched optical power without input to the transmitter.....40

8 OLT PMD Tests42

- 8.1 NG-PON2 Specific OLT PMD Layer Tests42
 - 8.1.1 *OLT Out of Channel Power Spectral Density Compliance – OOC PSD*..... 42
 - 8.1.2 *OLT Out of Band Power Spectral Density Compliance – OOB PSD*..... 43
- 8.2 General 10G-PON OLT PMD Layer Tests.....43
 - 8.2.1 *OLT Transmit Power*44
 - 8.2.2 *OLT Extinction Ratio* 45
 - 8.2.3 *OLT Receive Sensitivity* 45
 - 8.2.4 *OLT Transmit optical waveform (transmit eye)*..... 47
 - 8.2.5 *OLT Receive Overload*..... 47
 - 8.2.6 *Central OLT Wavelength Parameters Tests* 49
 - 8.2.7 *OLT Side Mode Suppression Ratio Parameter Tests*..... 50
 - 8.2.8 *OLT Receive Overload in dual rate operation* 50
 - 8.2.9 *OLT Receive Sensitivity in dual rate operation* 52
- 9 WDM Coexistence Test Cases for XGS-PON with GPON53
- 10 PON Optical Supervision Test Cases55

Table of Figures

Figure 1 Test Setup for MSE, OOC and OOB (VOA = Variable Optical Attenuator)12

Figure 2 - Optical eye pattern, waveform, and extinction ratio measurement configuration14

Figure 3 “OOC PDS Mask Definition” from G.989.2.....17

Figure 4 MSE and OOC Template Overlaid on Idealized Spectral Excursion Plot18

Figure 5 – Illustration of laser tuning across the operating band.....21

Figure 6 - Test Setup for Tuning Time of ONU Transmitter22

Figure 7 - Optical power vs. time from summation of waveform monitors22

Figure 8 – Test Setup for ONU Receiver Tuning Time24

Figure 9 – Test Setup for Upstream Optical PSD when not Enabled.....25

Figure 10 – Test Setup for ONU Transmit Power27

Figure 11 - Histograms centered in the central 20 % of the eye used to determine the mean logic one and 0 levels, b1 and b029

Figure 12 - Basic eye mask coordinate system.....30

Figure 13- (left) Mask margin with ~ 100 000 samples tested at a 1:10 000 hit ratio: 75 %. (right) Mask margin (76 %) with over 1 million samples and a 1:10 000 hit ratio.....32

Figure 14: Test Setup for ONU Receive Overload.....38

Figure 15: Test Setup Side Mode Suppression Ratio Parameter Tests.....39

Figure 16:: Test Setup for Allocation of the physical layer overhead time and launched optical power without input to the transmitter41

Figure 17 – Test Setup for OOC and OOB PSD42

Figure 18 – Test Setup for OLT Transmit Power.....44

Figure 19– Test Setup for OLT Receive Sensitivity46

Figure 20: Test Setup for OLT Receive Overload.....48

Figure 21: Test Setup for OLT Receive Overload in dual rate operations51

Figure 22: Test Setup for OLT Receive Sensitivity in dual rate operations52

Figure 23 – Test Setup for XGS-PON ONU Coexistence with GPON.....55

Figure 24: Test Setup for Optical supervision.....55

Table of Tables

Table 1 Summarized ONU PMD Tests14

Table 2 Summarized OLT PMD tests15

Table 3 CS and MSE values17

Table 4 ONU extinction ratio and OLT sensitivity adjustment.....46

1 Executive Summary

Operators that plan to use ITU-T XG(S)-PON (with or without XG-PON), and NG-PON2 need new PON Physical Media Dependent Layer (PMD) measurement methods to verify conformance of these optics to standards. In particular, NG-PON2, which uses Burst Mode TWDM-PON needs new measurement methods to be defined, such as measuring burst Spectral Excursion, Out of Band/Channel noise, tuning time and sensitivity over various extinction ratios.

This Technical Report defines new PON PMD measurement techniques and the test plan for use in PON PMD Conformance testing. Executing these test cases as part of a multi-supplier test event will help OLT's and ONU's implement the specifications so as to operate as a functional PON system.

Operators that plan to use ITU-T XG(S)-PON (with or without XG-PON), and NG-PON2 requested that the FSAN and BBF Groups document a PMD (Physical Media Dependent) layer test plan for Conformance Events. Executing these test cases as part of a multi-supplier test event will help OLT and ONU's implementation of the specifications operate as a functional system.

2 Purpose and Scope

2.1 Purpose

This test plan describes a series of tests that may be used by optical vendors or system vendors to verify whether optical transceivers (pluggable or on-board) meet the relevant ITU-T PMD requirements in:

- G.987.2
- G.989.2
- G.9807.1

2.2 Scope

The PMD test procedures in this document are not interoperability tests but rather are single ended testing using specialized optical test equipment. The test procedures are defined, however, to ensure interoperability

3 References and Terminology

3.1 Conventions

In this Technical Report, several words are used to signify the requirements of the specification. These words are always capitalized. More information can be found in RFC 2119 [9]

MUST	This word, or the term “REQUIRED”, means that the definition is an absolute requirement of the specification.
MUST NOT	This phrase means that the definition is an absolute prohibition of the specification.
SHOULD	This word, or the term “RECOMMENDED”, means that there could exist valid reasons in particular circumstances to ignore this item, but the full implications need to be understood and carefully weighed before choosing a different course.
SHOULD NOT	This phrase, or the phrase "NOT RECOMMENDED" means that there could exist valid reasons in particular circumstances when the particular behavior is acceptable or even useful, but the full implications need to be understood and the case carefully weighed before implementing any behavior described with this label.
MAY	This word, or the term “OPTIONAL”, means that this item is one of an allowed set of alternatives. An implementation that does not include this option MUST be prepared to inter-operate with another implementation that does include the option.

3.2 References

The following references are of relevance to this Technical Report. At the time of publication, the editions indicated were valid. All references are subject to revision; users of this Technical Report are therefore encouraged to investigate the possibility of applying the most recent edition of the references listed below.

A list of currently valid Broadband Forum Technical Reports is published at www.broadband-forum.org.

Document	Title	Source	Year
[1] OD-247/ IR-247	G-PON ONU Conformance Test Plan	BBF	2011
[2] TR-255	G-PON Interoperability Test Plan	BBF	2011
[3] G.987	10-Gigabit-capable passive optical network (XG-PON) systems: Definitions, abbreviations and acronyms (06/12)	ITU-T	2012
[4] G.987.1	10-Gigabit-capable passive optical networks (XG-PON): General requirements (01/10)	ITU-T	2010
[5] G.987.2	10-Gigabit-capable passive optical networks (XG-PON): Physical media dependent (PMD) layer specification (02/16)	ITU-T	2016

[6]	G.989.2	40-Gigabit-capable passive optical networks (NG-PON2): Physical media dependent (PMD) layer specification (12/14)	ITU-T	2014
[7]	G.988	ONU Management and Control Interface Specification (OMCI) (10/12)	ITU-T	2017
[8]	G.9807.1	10-Gigabit-capable symmetric passive optical network (XGS-PON) (06/16)	ITU-T	2016
[9]	RFC 2119	Key words for use in RFCs to Indicate Requirement Levels	IETF	1997

3.3 Definitions

The following terminology is used throughout this Technical Report.

Optical Distribution Network (ODN)	Optical Distribution Network including the fibers, splitters and connectors.
Optical Line Termination (OLT)	A device that terminates the common (root) endpoint of an ODN, implements a PON protocol, such as that defined by G.987, and adapts PON PDUs for uplink communications over the provider service interface. The OLT provides management and maintenance functions for the subtended ODN and ONUs.
Optical Network Unit (ONU)	Optical Network Unit (ONU): A generic term denoting a device that terminates any one of the distributed (leaf) endpoints of an ODN, implements a PON protocol, and adapts PON PDUs to subscriber service interfaces.
Optical test equipment	An external device, which may be included in a non-intrusive manner, between the R/S and S/R-interfaces to capture and/or analyze the signals and the traffic present in the ODN
XG-PON Network	An XG-PON OLT connected using an Optical Distribution Network (ODN) to one or more XG-PON ONUs. A XG-PON network is a subset of the Access Network. A XG-PON system supports nominal transmission rates on the order of 10 Gbit/s, and implements the suite of protocols specified in the ITU-T G.987.x series Recommendations. A XG-PON system operates at a nominal line rate of 10 Gbit/s downstream and 2.5 Gbit/s upstream.
XG(S)-PON Network	An XG(S)-PON OLT connected using an Optical Distribution Network (ODN) to one or more XG-PON or XGS-PON ONUs. A XG(S)-PON network is a subset of the Access Network. A XG(S)-PON system supports nominal transmission rates on the order of 10 Gbit/s in the OLT to ONU direction, and implements the suite of protocols specified in ITU-T G.987 and G.9807.1 Recommendations. A XG(S)-PON system operates at a nominal line rate of 10 Gbit/s downstream, 10Gbit/s and 2.5 Gbit/s upstream.

3.4 Abbreviations

This Technical Report uses the following abbreviations:

BSA	Burst Spectrum Analyzer
FEC	Forward Error Correction
NG-PON2	40-Gigabit-capable Passive Optical Network, ITU-T G.989 Series
ODN	Optical Distribution Network – as defined in G.987.1 [4]
OLT	Optical Line Termination – as defined in G.987.1, G.9807.1 & G.989.1
ONU	Optical Network Unit – as defined in G.987.1, G.9807.1 & G.989.1
OOC	Out of Channel
OOB	Out of Band
OSA	Optical Spectrum Analyzer
PLOAM	Physical Layer OAM
PLI	Payload Length Indication
PMD	Physical Media Dependent Layer
PSD	Power Spectral Density
TWDM	Time and Wavelength Division Multiplexing
TR	Technical Report
WA	Working Area
WT	Working Text
XG-PON	10-Gigabit-capable Passive Optical Network, ITU-T G.987.x-series
XGS-PON	10-Gigabit-capable Symmetric & Asymmetric Passive Optical Network, ITU-T G.9807.1
TR	Technical Report
WA	Work Area
WT	Working Text

4 Technical Report Impact

4.1 Energy Efficiency

TR-423 has no impact on energy efficiency.

4.2 Security

TR-423 has no impact on security.

4.3 Privacy

Any issues regarding privacy are not affected by TR-423.

5 Test Configuration and Equipment

5.1 Setup for MSE, OOC and OOB Tests

Applies to: G.989.2 only.

Test equipment:

1. Burst spectrum analyzer – composed of tunable narrowband filter, high speed photodetector, A/D converter and computer
2. Optical splitter
3. Optical attenuator
4. Traffic generator

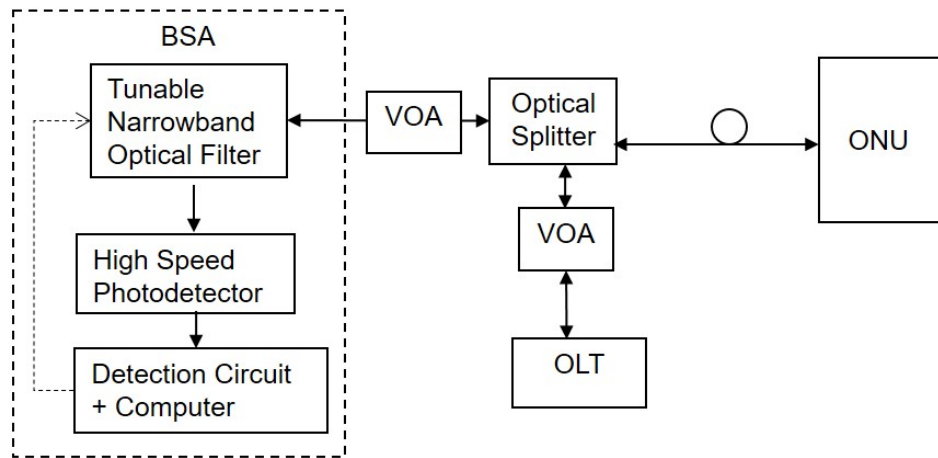

Figure 1 Test Setup for MSE, OOC and OOB (VOA = Variable Optical Attenuator)

MSE, OOC and OOB Test Configuration Details

The test configuration for Maximum Spectral Excursion and Out of Channel noise is shown in the diagram above. The components in the dotted line box comprise a Burst Spectrum Analyzer (BSA). The BSA is connected to the ODN via fiber to an optical splitter. The connection from the Detection Circuit and Computer is a logical control connection that allows the Detection Circuit and Computer to step the tunable filter through the entire spectrum to be measured as the detection circuit has completed the power measurement for each step. The reason the BSA is shown with internal components is that a conventional OSA may not have the properties required to measure spectral excursion. The properties of a spectrum analyzer needed to make this measurement include a fast-enough response time to capture spectral components that may only be present for nanoseconds. It is also preferable that the wavelength scanning is slow enough such that only one pass through the channel is needed to capture all the spectral components in one sweep. Given that the spectral components depend on the ONU burst duty cycle, it is desirable that the dwell time of the wavelength scanning filter is slow enough to capture many burst cycles for each wavelength step of 0.01nm. Therefore, the properties of the BSA components are:

- Tunable Narrowband Optical Filter – Filter Bandwidth = 0.01nm (for MSE measurement) and 15GHz (for OOC and OOB measurements). If the exact bandwidths above cannot be obtained the power limits must be scaled accordingly but if the bandwidth is significantly larger than the above, compliant optics may be erroneously rejected.
- Filter step size: 0.005nm or less
- Filter scan speed: No faster than 1ms per step
- High Speed Photodetector – 10 to 15 GHz electrical bandwidth

- Peak detection circuit (digital or analog) with 10 to 15 GHz bandwidth capable of detecting the peak (not average) optical power at every filter step and calibrated to an absolute power level of 0.5dB and a repeatability of 0.1dB.

5.2 Setup for Extinction Ratio and Transmit Eye Measurements

Applies to: G.987.2, G.989.2, and G.9807.1.

A filtered response using the appropriate reference receiver described in Section 5.2.1 is used except where noted. Allow sufficient warm-up time for the test instrumentation. Perform any instrument calibrations recommended by the manufacturer. Of particular importance to eye-diagram extinction ratio testing is a “dark cal” or dark level calibration. Any residual signal present within the oscilloscope when there is no optical signal present at the input is known as the dark level. Measuring and removing the dark level ‘bdark’ will enhance the accuracy of the extinction ratio measurement. Dark levels are determined by placing a vertical histogram about the signal trace observed on the oscilloscope when absolutely no signal is present at the oscilloscope input. ‘bdark’ is the mean level of the histogram. For best accuracy, dark calibrations should be performed at the oscilloscope vertical scale and offset setting at which extinction ratio measurements are made. Thus, a dark cal may need to be repeated after the transmitter signal levels have been observed. Apply appropriate terminal input voltage/power to the system under test. Follow appropriate operating conditions. Allow sufficient time for the terminal or transmitter under test to reach steady-state temperature and performance conditions.

As part of standard operating conditions, all transmitter inputs are fully loaded with a signal at the full signaling rate and with a pattern that has spectral content representative of actual operation. Acceptable signals are defined by the relevant communications standards, otherwise this is often achieved with pseudo-random data (typically 231 –1). Test patterns can be constructed that represent actual communications signals, yet are much shorter than pseudo-random 231 –1 sequences. These can be appropriate for test scenarios where extremely long test patterns are problematic for some oscilloscope architectures.

Use appropriate optical fiber cables; if necessary connect the input of the O/E converter to the optical interface point being tested.

Adjust the trigger setup and level of the oscilloscope to achieve a stable waveform display.

Determine the signaling rate of the optical signal to be tested. Select the appropriate reference receiver frequency response corresponding to the signaling rate and controlling specification.

Connect the test equipment, as shown in Figure 2. Verify that the waveform shape is not corrupted through averaging or excess power into the oscilloscope. As necessary, adjust the optical attenuator to set the reference receiver input power within the input power level range specified by the manufacturer.

Set the horizontal time base of the oscilloscope to display approximately 1,2 or more unit intervals, with at least one complete eye displayed. Unless the test system is capable of using data outside of a single unit interval, displays of multiple unit intervals lead to inefficient data acquisition, as only one unit interval (or one eye diagram) is analyzed in most automatic measurement systems.

Set the vertical scale of the oscilloscope such that the entire waveform is observed on the screen. Typically, measurement accuracy is improved if the majority of the vertical scale is used. (Example, if the vertical scale is eight divisions, the waveform is displayed across six or seven divisions.) It is common for automatic sampling oscilloscopes to achieve optimal horizontal and vertical scaling of the eye diagram through an ‘auto scale’ function, which should display the eye pattern across most of the available vertical scale.

The burst mode detection circuit in Figure 2 is used to generate burst mode trigger (BM trigger) for the reference receiver and optical power meter. The BM trigger indicates when an upstream burst mode signal is stable. The means of detecting burst mode could be as simple as power detection, or for periodic bursts could use periodic timers to indicate the start and end of the burst. The BM detector circuit should also operate in continuous mode.

5.2.1 Reference receiver definition

A reference receiver typically follows a fourth-order low-pass Bessel response. A well-defined lowpass frequency response will yield consistent results across all test systems that conform to the specification. A low-pass response reduces test system noise and approaches the bandwidth of the actual receiver that the transmitter will be paired with in an actual communications system. As signal transients such as overshoot and ringing, which can lead to eye mask failures, are usually suppressed by the reduced bandwidth of the system receiver, it is appropriate to use a similar bandwidth in a transmitter test system. The Bessel phase response yields near constant group delay in the passband, which in turn results in minimal phase distortion of the time domain optical waveform. The bandwidth of the frequency response typically is set to 0,75 (75 %) of the signaling rate. For example, the reference receiver for a 10,0 GBd signal would have a -3 dB bandwidth of 7,5 GHz. For non-return to zero (NRZ) signals, this response has the smallest bandwidth that does not result in vertical or horizontal eye closure (inter-symbol interference). When the entire test system achieves the fourth-order Bessel low-pass response with a bandwidth of 75 % of the baud rate, this is referred to as a Bessel-Thomson reference receiver.

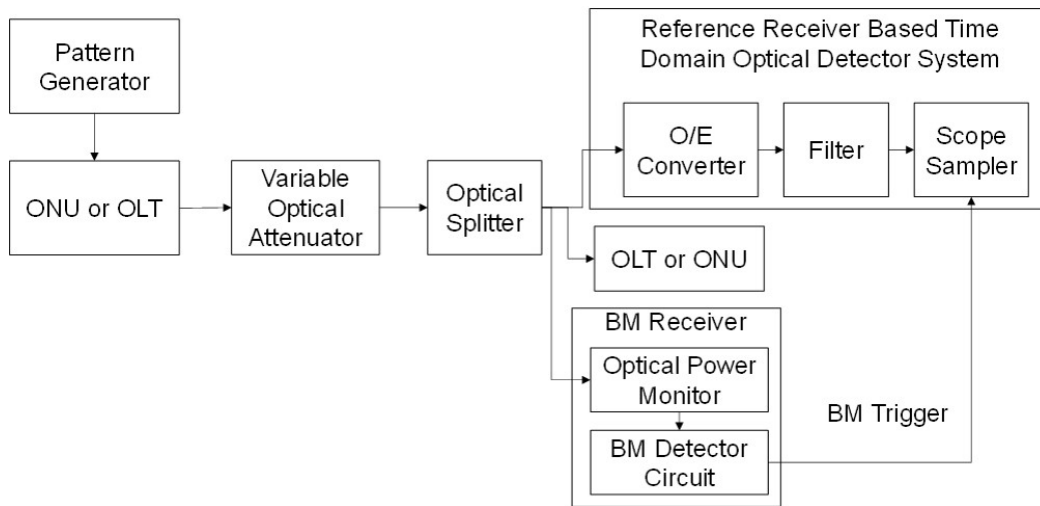

Figure 2 - Optical eye pattern, waveform, and extinction ratio measurement configuration

6 Test Case Summary

6.1 General

This section contains a summary of PMD Layer tests, as applicable to different use cases. Test sets are partitioned according to OLT downstream and upstream line rate combinations: 10/2.5, 10/10 and dual rate upstream (10/10+2.5). A system which claims to support a given combination of line rates is expected to comply with the full corresponding test set; this is indicated by Mandatory in the corresponding column of the table below. A system which does not claim to support a given combination of line rates is not expected to comply with the full corresponding test set.

6.2 PMD Layer Tests

Table 1 Summarized ONU PMD Tests

ONU PMD Tests	Section Applies To	Line Rates		
Test Name		10G/2.5G	10G/10G	10G/10G+2.5G

					TDMA Coexistence
ONU Short Term Spectral Excursion (MSE Compliance)	7.1.1	NG-PON2	Mandatory	Mandatory	N/A
ONU Out of Channel Power Spectral Density Compliance – OOC PSD	7.1.2	NG-PON2	Mandatory	Mandatory	N/A
ONU Out of Band Power Spectral Density Compliance – OOB PSD	7.1.3	NG-PON2	Mandatory	Mandatory	N/A
ONU Transmitter Tuning Time	7.1.4	NG-PON2	Mandatory	Mandatory	N/A
ONU Receiver Tuning Time	7.1.5	NG-PON2	Mandatory	Mandatory	N/A
ONU Maximum Upstream Optical PSD when not Enabled	7.1.6	NG-PON2	Mandatory	Mandatory	N/A
ONU Optical Path Penalty	7.1.7	NG-PON2	Mandatory	Mandatory	N/A
ONU Transmit Power	7.2.1	NG-PON2, XGS-PON, XG-PON	Mandatory	Mandatory	N/A
ONU Extinction Ratio	7.2.2	NG-PON2, XGS-PON, XG-PON	Mandatory	Mandatory	N/A
ONU Transmit optical waveform (transmit eye)	7.2.3	NG-PON2, XGS-PON, XG-PON	Mandatory	Mandatory	N/A
ONU Rx Sensitivity	7.2.4	NG-PON2, XGS-PON, XG-PON	Mandatory	Mandatory	N/A
Central ONU Wavelength	7.2.5	XGS-PON, XG-PON	Mandatory	Mandatory	N/A
ONU Filtering	7.2.6	NG-PON2, XGS-PON, XG-PON	Mandatory	Mandatory	N/A
ONU Receive Overload	7.2.7	NG-PON2, XGS-PON, XG-PON	Mandatory	Mandatory	N/A
ONU SMSR	7.2.8	XGS-PON, XG-PON	Mandatory	Mandatory	N/A
ONU Overhead and Off Burst Power	7.2.9	NG-PON2, XGS-PON, XG-PON	Mandatory	Mandatory	N/A
WDM Coexistence Test Cases for XG(S)-PON with GPON	9	XGS-PON, XG-PON	NA	Mandatory	NA
PON Optical Supervision Test Cases (ONU and OLT)	10	NG-PON2, XGS-PON, XG-PON	NA	Mandatory	NA

Table 2 Summarized OLT PMD tests

OLT PMD Tests	Section	Applies To	Line Rates		
Test Name			10G/2.5G	10G/10G	10G/10G+2.5G TDMA Coexistence
OLT Out of Channel Power Spectral Density Compliance – OOC PSD	8.1.1	NG-PON2	Mandatory	Mandatory	N/A
OLT Out of Band Power Spectral	8.1.2	NG-PON2	Mandatory	Mandatory	N/A

Density Compliance – OOB PSD					
OLT Transmit Power	8.2.1	NG-PON2, XGS-PON, XG-PON	Mandatory	Mandatory	N/A
OLT Extinction Ratio	8.2.2	NG-PON2, XGS-PON, XG-PON	Mandatory	Mandatory	N/A
OLT Rx Sensitivity	8.2.3	NG-PON2, XGS-PON, XG-PON	Mandatory	Mandatory	Optional
OLT Transmit optical waveform (transmit eye)	8.2.4	NG-PON2, XGS-PON, XG-PON	Mandatory	Mandatory	N/A
OLT Receive Overload	8.2.5	NG-PON2, XGS-PON, XG-PON	Mandatory	Mandatory	Optional
OLT Central Wavelength	8.2.6	XGS-PON, XG-PON	Mandatory	Mandatory	N/A
OLT SMSR	8.2.7	XGS-PON, XG-PON	Mandatory	Mandatory	N/A
OLT Receive Overload in Dual Rate Operation	8.2.8	NG-PON2, XGS-PON, XG-PON	Mandatory	Mandatory	Mandatory
OLT Receive Sensitivity in Dual Rate Operation	8.2.9	XGS-PON, XG-PON	Mandatory	Mandatory	Mandatory

Note: The material in the following clauses is largely drawn from IEC 61280-2-2 "Fiber optic communication subsystem test procedures – Part 2-2: Digital systems – Optical eye pattern, waveform and extinction ratio measurement", clauses 4.2, 7.2, and 8:

- ONU Extinction Ratio
- ONU Transmit optical waveform (transmit eye)
- ONU Rx Sensitivity
- OLT Extinction Ratio
- OLT Transmit optical waveform (transmit eye)

7 ONU PMD Layer Tests

7.1 NG-PON2 Specific ONU PMD Layer Tests

7.1.1 ONU Short Term Spectral Excursion (MSE Compliance)

Reference Documents:

- ITU-T G.989.2 [6], Table 11-6 and 11-7, Figure 9-1 – OOC PSD mask definition

Test Objective:

Verify that the ONU optical spectrum stays within the Maximum Spectral Excursion (MSE) for both 10 Gbit/s and 2.5 Gbit/s upstream bursts over any allowable burst duty cycles.

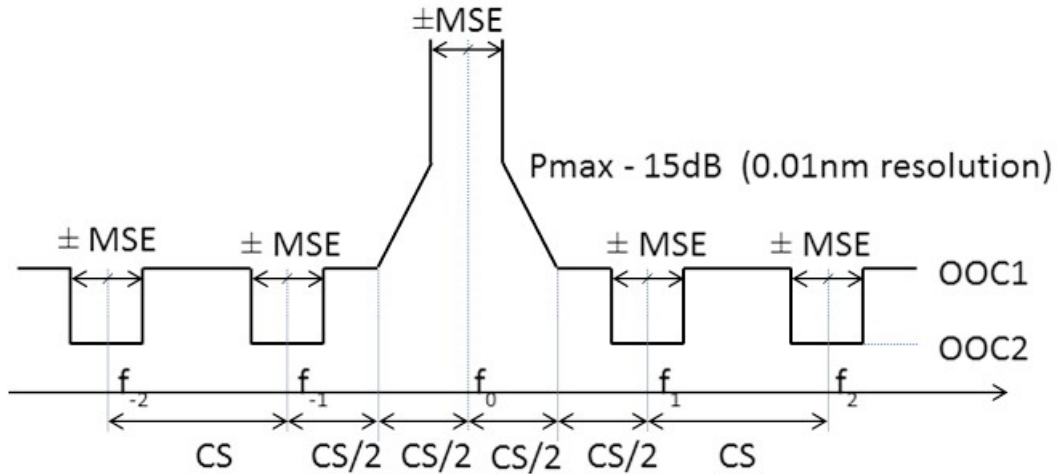

Figure 3 “OOC PDS Mask Definition” from G.989.2

For example, if 100 GHz upstream channel spacing is used the following values are relevant for both the 2.5 Gbit/s and 10 Gbit/s upstream signals. While this test plan breaks up the upstream spectral tests into three parts: MSE, OOC, and OOB, the test setup for these may be largely the same.

Table 3 CS and MSE values

Parameter	Value	Units
CS	100	GHz
MSE	20	GHz

Total Spectral Excursion and Burst Duty Cycle

To obtain the total spectral excursion, it is necessary to test the ONU transmitter over a wide range of duty cycles. An example of how duty cycle may change the nature of the wavelength content in the transmitted burst is shown in Figure 4. Note that this data was manipulated to represent an idealized measurement. Both the nominal wavelength and the spectral shift of the burst may change, depending on the duty cycle. This is due to the cooling that occurs between bursts. For example, a lower duty cycle allows more cooling in between bursts. To map out the total spectral excursion of a transmitter, the minimum and maximum duty cycles must be tested as well as duty cycles in between. In the figure below, an example spectral plot of a laser with multiple burst durations is plotted against the MSE and OOC template from G.989.2. As can be seen this laser would not pass.

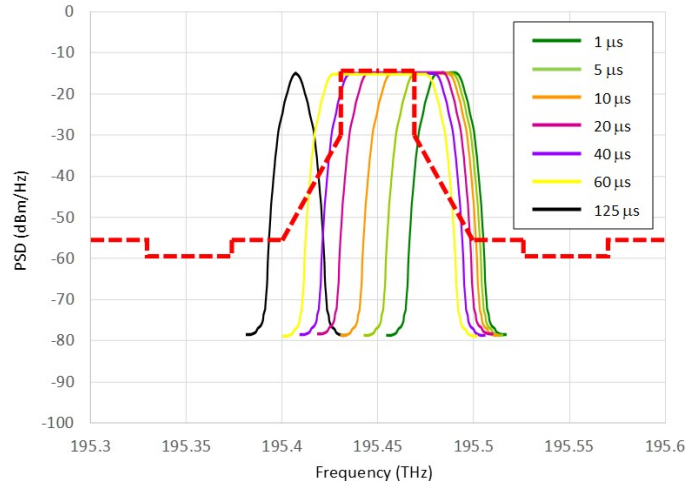

Figure 4 MSE and OOC Template Overlaid on Idealized Spectral Excursion Plot

Pretest Conditions:

1. The OLT and ONU are powered and connected according to the test setup shown in Figure 1 of section 5.5.1.
2. Data generators should be connected to the OLT and ONU for providing the traffic load as needed by the test.
3. The BSA is set for max hold with a resolution bandwidth to 0.01nm (for MSE) and 15GHz (for OOC and OOB). If the exact bandwidths above cannot be obtained the power limits must be scaled accordingly but if the bandwidth is significantly larger than the above, compliant optics may be erroneously rejected.
4. The BSA should have the OOC PSD mask template as a go/no-go template for the Channel Termination (CT) wavelength being tested.
5. The OLT scheduler must be capable of granting bandwidth in defined duty cycles as below:
 - a. Low Duty Cycle (LDC): Bursts with 1 microsecond on per 1 millisecond period
 - b. Medium Duty Cycle (MDC): Bursts with 62.5 microsecond on and 62.5 microsecond off
 - c. High Duty Cycle (HDC): Bursts with 124.8 microseconds on per 125 microsecond period

Test Procedure MSE:

1. Tune the ONU to the first TWDM wavelength
2. Set OLT scheduler to grant LDC bursts to ONU DUT.
3. Set data generator in the upstream to an appropriate rate to fill all upstream bursts.
4. Check that data is successfully received at the OLT.
5. Run BSA in max hold condition* until spectrum is stable
6. Determine whether spectrum falls below the template within +/- CS/2 (Channel Spacing divided by 2)
7. If spectrum is below template, ONU passes this portion of the spectral excursion test
8. Adjust duty cycle to MDC.
9. Run steps 3 to 7
10. Adjust duty cycle to HDC.
11. Run steps 3 to 7.
12. Tune the ONU to the second TWDM wavelength
13. Run steps 2 through 11
14. Tune the ONU to the next TWDM wavelength and repeat until all wavelengths are tested.

*Max hold condition means that the spectrum is not averaged but rather the peak power measured at any given wavelength is plotted and used for pass/fail under the spectral mask.

Pass/Fail Criteria

If all wavelengths and duty cycles are tested and the measured power is below the MSE portion of the OOC PSD mask in all of the tests, the ONU passes this test.

7.1.2 ONU Out of Channel Power Spectral Density Compliance – OOC PSD

Reference Documents:

- ITU-T G.989.2 [6], Tables 11-6 and 11-7, Figure 9-1 – OOC PSD mask definition

Test Objective:

Verify that the ONU optical spectrum PSD is below the OOC-PSD mask in Figure 9-1 of G.989.2.

Test Setup:

As shown above for MSE test

Pretest Conditions:

As per MSE test above.

Test Procedure OOC PSD:

1. Tune the ONU to the first TWDM wavelength
2. Set OLT scheduler to grant LDC bursts to ONU DUT.
3. Set data generator in the upstream to an appropriate rate to fill all upstream bursts.
4. Check that data is successfully received at the OLT.
5. Run BSA in max hold condition* until spectrum is stable
6. Determine whether spectrum falls below the template in the OOC1 and OOC2 regions
7. If spectrum is below template, ONU passes this portion of the spectral excursion test
8. Adjust duty cycle to MDC.
9. Run steps 3 to 7
10. Adjust duty cycle to HDC.
11. Run steps 3 to 7.
12. Tune the ONU to the second TWDM wavelength
13. Run steps 2 through 11
14. Tune the ONU to the next TWDM wavelength and repeat until all wavelengths are tested.

*Max hold condition means that the spectrum is not averaged but rather the peak power measured at any given wavelength is plotted and used for pass/fail under the spectral mask.

Pass/Fail Criteria

If all wavelengths and duty cycles are tested and the measured power is below the OOC1 and OOC2 regions of the OOC PSD mask in all of the tests, the ONU passes this test.

7.1.3 ONU Out of Band Power Spectral Density Compliance – OOB PSD

Reference Documents:

- ITU-T G.989.2 [6], Figure 9-1 and Tables 11-6 and 11-7

Test Objective:

Verify that the ONU out of band optical spectrum complies with the power spectral density defined in the G.989.2 Tables 11-6 and 11-7.

Test Setup:

As shown above for MSE test

Pretest Conditions:

As per MSE test above

Test Procedure OOB PSD:

1. Tune the ONU to the first TWDM wavelength
2. Set OLT scheduler to grant LDC bursts to ONU DUT.
3. Set data generator in the upstream to an appropriate rate to fill all upstream bursts.
4. Check that data is successfully received at the OLT.
5. Run BSA in max hold condition* until spectrum is stable
6. Determine whether spectrum falls below the OOB power spectral density over all wavelengths (1250nm to 1660nm) outside of the TWDM upstream band
7. If spectrum is below requirement, ONU passes this portion of the OOB test
8. Adjust duty cycle to MDC.
9. Run steps 3 to 7
10. Adjust duty cycle to HDC.
11. Run steps 3 to 7.
12. Tune the ONU to the second TWDM wavelength
13. Run steps 2 through 11
14. Tune the ONU to the next TWDM wavelength and repeat until all wavelengths are tested.

*Max hold condition means that the spectrum is not averaged but rather the peak power measured at any given wavelength is plotted and used for pass/fail under the spectral mask.

Pass/Fail Criteria

If all wavelengths and duty cycles are tested and the measured power is below the OOB requirements, the ONU passes this test.

7.1.4 ONU Transmitter Tuning Time

Reference Documents:

- ITU-T G.989.2 Table 9-2 and Appendix VIII

Test Objective:

Determine which of the three tuning time classes (1, 2 or 3) the ONU transmitter conforms to.

Test Setup:

As shown below in test setup in Figure 6

Pretest Conditions:

This test may be done with the ONU transceiver tested separately from an ONU and unconnected to an OLT or it may be done with as a system test with the ONU optics in the ONU, the ONU connected to an ODN and OLT, with the ONU ranged to the OLT and in an operational state. In the case of the test of the optical module alone, tuning command may be done with low level triggers and with a full system as per tuning PLOAM commands. The procedure below is focused on the actual movement of the laser spectrum from one channel to another. In an OLT/ONU system test, the criteria for tuning time may be from command to downstream/upstream communication restoral or in the case of a loss of PON (due to fiber pull at CT for example) from loss of optical signal to service restoral.

Test Procedure:

The ONU transmitter wavelength channel transmitter tuning time may be measured using the procedure and test setup below. The purpose of the test setup is to measure the tuning time unambiguously. The tuning of the laser is illustrated in the figure below.

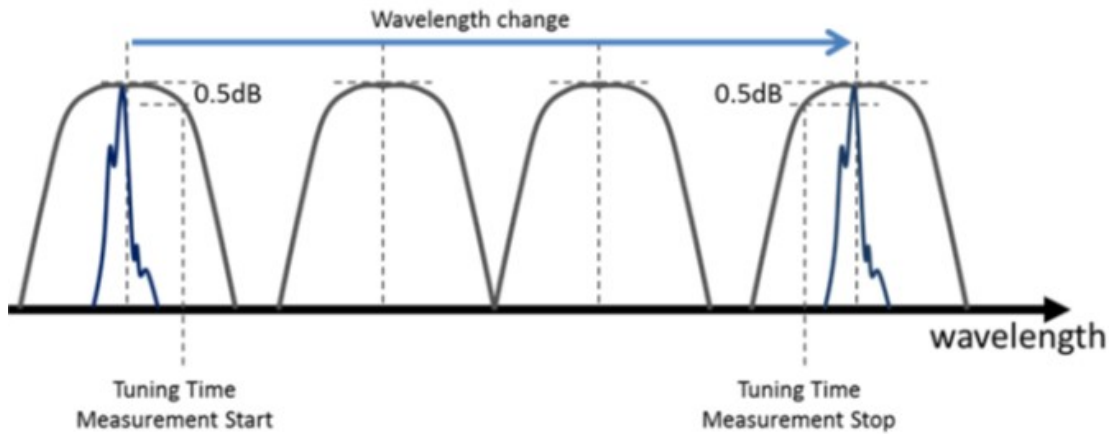

Figure 5 – Illustration of laser tuning across the operating band

The tuning time as shown in the illustration does not begin when the laser begins to tune but when the laser exits the passband of the origin wavelength channel, i.e. when the optical power drops by some defined threshold (e.g. 0.5dB) compared to the initial value, after a channel change command is issued. The tuning time ends when the laser enters the passband of the destination wavelength channel, i.e. when the optical power, in the destination wavelength channel, reaches and stays above the threshold value. The transmitter wavelength channel tuning time is computed over all possible channel changes in the tuning range. A reference channel demultiplexer is used in the test setup. The reference test demultiplexer should be Gaussian in shape and should have a relative loss of < 0.4dB at 12GHz from the minimum loss point.

The two illustrations below show the test setup in Figure 6 and how the parameter of tuning time is measured in Figure 7.

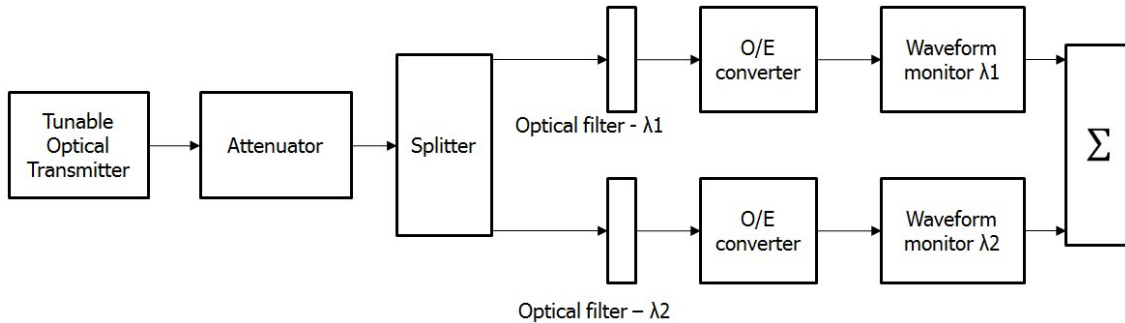

Figure 6 - Test Setup for Tuning Time of ONU Transmitter

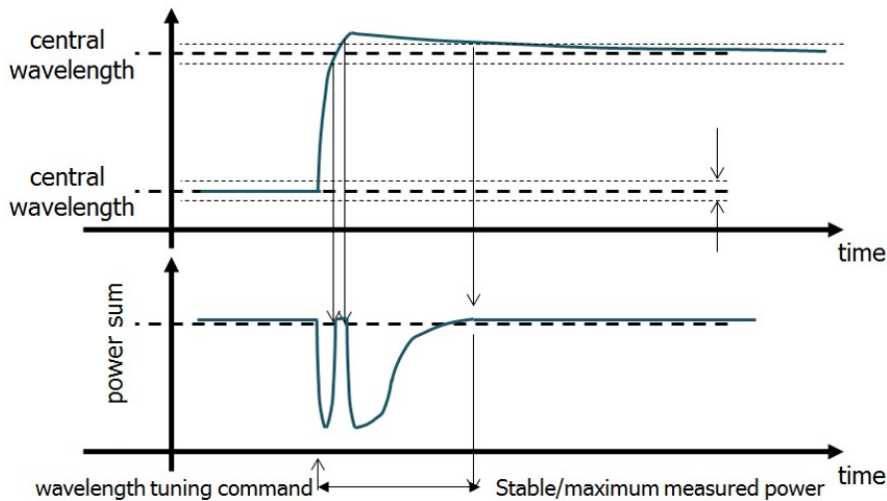

Figure 7 - Optical power vs. time from summation of waveform monitors

The test set up attenuator is set such that the optical received power at the O/E converters is in range that is not close to receiver overload and the signal is high enough to be accurately measured. The laser is initially tuned to within 0.1dB of the minimum loss point of the filter. To determine the beginning of the laser tuning process, an optical power drop threshold is defined (such as 0.5dB) where the tuning time starts when the power drops below the initial power measurement by the defined threshold. The crossing of this threshold will be used to determine the points where the tuning time begins and in a similar fashion when the tuning time ends, i.e. the signal stays stably above the threshold.

The optical power levels are converted and measured at the output of the summation box in the electrical domain.

Note that the same test procedure can be applied even when the transmitter module is integrated in a system and the channel change command is issued via higher layers, e.g. CLI or EMS. However, it must be understood that other effects may influence the measurement in this case, e.g. the fact that the transmitter may be switched off before tuning initiates and switched on again when tuning finishes. Hence the test procedure can be applied e.g. to compare the tuning time of different ONUs, excluding command transmission and processing delays, but the tuning time of the optical module itself is measured when the optical module is not part of a system and the channel change is commanded via the specific signal required by the optical module.

Pass/Fail Criteria: For a given class, the laser will fail if the tuning time measured from the procedure above exceeds the maximum allowed tuning time for that class. For a low-level optical test (testing the ONU optical module alone) the time is measured as per the procedure above. For an OLT/ONU system test the pass/fail may include the entire time from the Tuning_Control PLOAM command to service restoral.

Remarks: The tuning time classes are quite broad. Less precise tuning measurements are allowable if the tuning time of the laser is not near a class boundary.

Tuning Time Test Steps

Test setup as above.

1. Tuning command from Channel 1 to Channel 2 issued via low level driver (e.g. I²C) or via OLT PLOAM and timer started simultaneously with command.
2. Waveform captured as per Figure 7. (Optional: Downstream synchronization of ONU or upstream communication restoral from ONU to OLT may also be monitored and time from tuning command measured).
3. The tuning time is the time from when the optical power from filter λ_1 drops below the defined power drop threshold of the initial power to the time the optical power in filter λ_2 is stably above the power drop threshold of the final power. Note that the final power must be within 0.4dB of the peak power (minimum loss wavelength of the wavelength multiplexer) indicating that the laser is within the passband of the multiplexer and within MSE. (Optional: The tuning time may be measured from the time of the tuning command rather than when the laser power drops by defined amount from initial value if the delay from the tuning command to actual laser movement is to be included in the tuning time).
4. Steps 1 – 3 are repeated from Channel 1 to Channels 3 and 4.
5. Steps 1 – 3 are repeated starting from Channel 2 to Channels 1, 3 and 4.
6. Steps 1 – 3 are repeated starting from Channel 3 to Channels 1, 2 and 4.
7. Steps 1 – 3 are repeated starting from Channel 4 to Channels 1, 2 and 3.

The above procedure is for a 4-channel system but may be extended to an 8-channel system.

7.1.5 ONU Receiver Tuning Time

Reference Documents:

- ITU-T G.989.2 Table 9-2

Test Objective:

Determine which of the three tuning time classes (1, 2 or 3) the ONU receiver conforms to.

Test Setup:

The receiver tuning time cannot be independently measured as an optical module as easily as the transmitter as the spectrum is not externally visible. One approach is to measure tuning time from initiation of a tuning command from the ONU to the optical module to synchronization restoral at the data analyzer. Another approach is to measure it optically. This is difficult as it requires access to internal optics. Only the

synchronization restoral will be described below. It is recommended that the receiver tuning time be measured within an OLT/ONU system configuration.

Pretest Conditions:

The OLT and ONU are powered and connected according to the test setup below. The OLT must have active Channel Terminations (CTs) for all channels to be tested. The data analyzer or Sync detector must be able to detect loss of sync and regain of sync within 1ms.

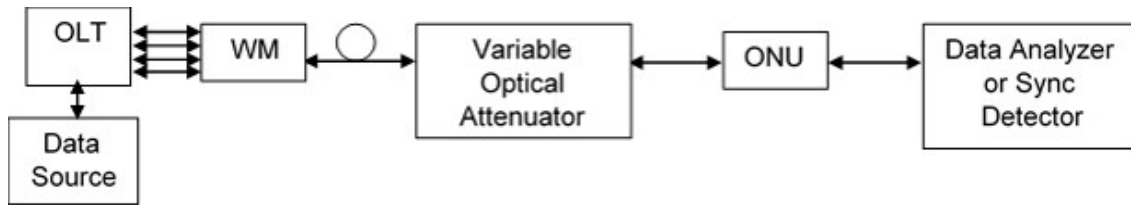

Figure 8 – Test Setup for ONU Receiver Tuning Time

Test Procedure – Synchronization Restoral:

1. Tuning command from Channel 1 to Channel 2 issued via low level driver (e.g. I²C) or via OLT PLOAM and timer started simultaneously with command.
2. Waveform captured as per Figure 7. (Optional: Downstream synchronization of ONU or upstream communication restoral from ONU to OLT may also be monitored and time from tuning command measured).
3. The tuning time is the time from when the optical power from filter λ_1 drops below the defined power drop threshold of the initial power to the time the optical power in filter λ_2 is stably above the power drop threshold of the final power. Note that the final power must be within 0.4dB of the peak power (minimum loss wavelength of the wavelength multiplexer) indicating that the laser is within the passband of the multiplexer and within MSE. (Optional: The tuning time may be measured from the time of the tuning command rather than when the laser power drops by defined amount from initial value if the delay from the tuning command to actual laser movement is to be included in the tuning time).
4. Steps 1 – 3 are repeated from Channel 1 to Channels 3 and 4.
5. Steps 1 – 3 are repeated starting from Channel 2 to Channels 1, 3 and 4.
6. Steps 1 – 3 are repeated starting from Channel 3 to Channels 1, 2 and 4.
7. Steps 1 – 3 are repeated starting from Channel 4 to Channels 1, 2 and 3.

Pass/Fail Criteria:

The ONU passes for any given class if the tuning time measured for all channel combinations is less than the maximum for the class.

7.1.6 ONU Maximum Upstream Optical PSD when not Enabled (WNE-PSD)

Reference Documents:

- ITU-T G.989.2 [6], Tables 11-6 and 11-7

Test Objective:

Verify that the ONU spectrum complies with the power spectral density when not enabled defined in the G.989.2 Tables 11-6 and 11-7.

Test Setup:

As shown in diagram below. The optical switch is controlled by the OLT scheduler to switch the optical signal to the BSA off when the OLT is expecting an upstream transmission from the ONU. The purpose of this switch is to block ONU management bursts to allow proper measurement of the ONU power when not enabled.

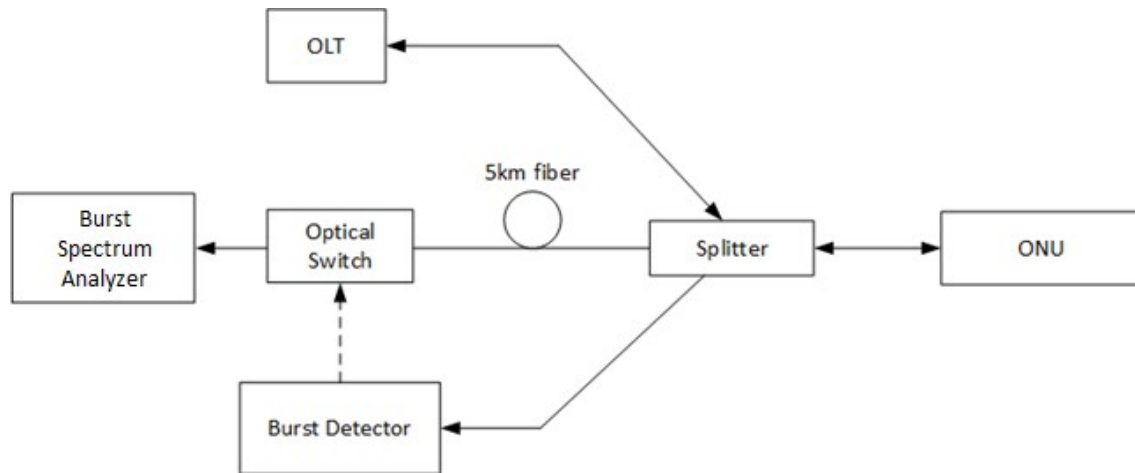

Figure 9 – Test Setup for Upstream Optical PSD when not Enabled

Pretest Conditions:

The OLT and ONU are powered and connected according to the test setup above. The ONU is ranged and configured to be transmitting at a regular Low Duty Cycle (LDC): Bursts with 1 microsecond on per 1 millisecond period as per the MSE test above may be used. In section 5.5.2 and figure 2, an optical burst detector is described and shown respectively.

The optical Burst Detector is capable of detecting optical bursts from the ONU and sending a signal to the optical switch to turn the switch to an Off position when a burst is detected and to an On position when the burst is no longer detected. This is to prevent any light getting to the spectrum analyzer during times when the ONU is transmitting a burst. The purpose of the 5km fiber coil is to add a delay of 25 microseconds to the signal from the splitter to the spectrum analyzer. The burst detector and optical switch must have a response time of less than 25 microseconds. If this is not possible then additional fiber of up to 20 km may be added to increase the delay to 100 microseconds. The burst detector must also have the ability to delay the signal to turn on and off the optical switch. The purpose of this is to be able to make sure that the switch will close just before the burst begins and just after the burst ends.

Test Procedure:

Under LDC conditions, the optical spectrum PSD in a 15 GHz resolution bandwidth should be measured over the entire TWDM upstream spectrum.

Pass/Fail Criteria:

The ONU passes this test if the WNE-PSD does not exceed the levels in Tables 11-6 and 11-7.

7.1.7 ONU Optical Path Penalty (OPP)

Reference Documents:

- ITU-T G.989.2 [6], Tables 11-6 and 11-7

Test Objective:

Verify that the upstream OPP complies with the requirements defined in the reference documents.

Test Setup:

Same as 7.2.3 (OLT Receive Sensitivity)

Pretest Conditions:

Same as 7.2.3 (OLT Receive Sensitivity)

Test Procedure:

1. Perform the OLT receive sensitivity (section 7.2.3) test procedure with 0, 10 and 20 km rolls of fiber, with the resulting sensitivity values of $Sens_{0km,dB}$, $Sens_{10km,dB}$ and $Sens_{20km,dB}$, respectively.
2. The OPP value is $\max(Sens_{10km,dB} - Sens_{0km,dB} ; Sens_{20km,dB} - Sens_{0km,dB} ; 0)$

Pass/Fail Criteria:

For NGPON2 10G upstream, pass if $OPP \leq 2dB$. This is derived from $X=1.5dB$ in Note 18 of Table 11-7/G.989.2.

For NGPON2 2.5G upstream, pass if OPP is less than value in Table 11-6/G.989.2.

7.2 General 10G-PON ONU PMD Layer Tests

7.2.1 ONU Transmit Power

Reference Documents:

- ITU-T G.987.2 Table 9-4
- ITU-T G.989.2 [6], Table 11-7

- ITU-T G.9807.1, Table B.9-4

Test Objective:

Verify that the ONU transmit power complies with the requirements defined in G.987.2, G.9807.1, G.989.2,

Test Setup:

As shown in diagram below. The OLT and ONU upstream power level can be measured by PON Power meters developed for field testing having the ability to be inserted between the OLT and ONU in a 'pass-through' mode to allow the system to operate while measuring signal levels both upstream and downstream.

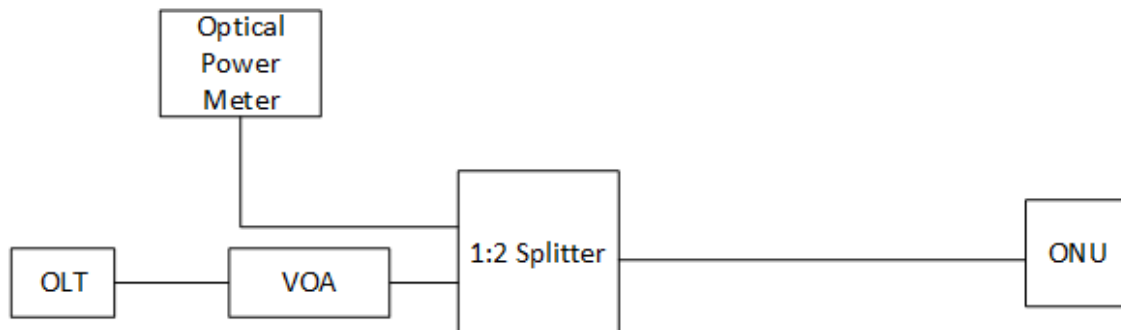

Figure 10 – Test Setup for ONU Transmit Power

Pretest Conditions:

The OLT and ONU are powered and connected according to the test setup in Figure 10.

Test Procedure:

1. Insert PON power meter using fiber jumper between optical splitter and ONU; at ONU end. The jumper should be between ONU and meter.
2. Allow ONU to range with OLT.
3. Record Upstream power reading.
4. Verify Mean Channel Launch Power is between levels indicated in G.987.2, G.989.2 and G.9807.1 for specified ODN Class.

Optical power shall meet specifications according to the methods specified in ANSI/EIA-455-95. A measurement may be made with the port transmitting any valid data stream.

Transmit Power Adjustment for Extinction Ratio Deviation

For G.989.2 10G upstream, follow the procedure described above, but with the minimum required transmit power adjusted as described below.

Measure the upstream transmit extinction ratio (section 6.2.2 of this document) and the optical path penalty in the upstream direction (section 6.1.7 of this document), and call these measurements $ER_{US, dB}$ and $OPP_{US, dB}$, respectively.

G.989.2 amendment 2 allows extinction ratios (ER) above and below the nominal 6dB specified for ONUs. For ONUs with ERs that deviate substantially from 6dB, the required minimum ONU transmit power will vary according to the formula in G.989.2 amendment 2. For example, the ONU is required to transmit at a 1dB higher

Tx level than specified if it has a relaxed ER of 5dB rather than 6dB. Transmit power adjustments for extinction ratios in-between the values in the table below are linearly interpolated. Let the minimum transmit power adjustment due to extinction ratio be called TxPwrAdj_{ER,dB}, and its value is linearly interpolated from the table below.

ONU Extinction Ratio (dB) (ER_{US,dB})	8.0	6.0	5.0	4.0
OLT Minimum Transmit Power Adjustment due to ER (dB) (TxPwrAdj_{ER,dB})	-1	0	+1	+3

Transmit Power Adjustment for Excess Optical Path Penalty

G.989.2 amendment 2 allows for an optical path penalty (OPP) up to 2dB for 10Gbps upstream operation. For OPP_{US,dB} between 0.5dB and 2dB, then minimum transmit power adjustment due to OPP (TxPwrAdj_{OPP,dB}) is equal to:

$$\text{TxPwrAdj}_{\text{OPP,dB}} = \text{OPP}_{\text{US,dB}} - 0.5 \text{ dB}$$

The ONU transmit power test passes if the measured transmit power is less than the Mean channel launch power maximum (at R/S) and greater than:

$$\text{Mean channel launch power minimum (at R/S)} + \text{TxPwrAdj}_{\text{ER,dB}} + \text{TxPwrAdj}_{\text{OPP,dB}}$$

As an example, if ER_{US,dB} = 4.5dB and OPP_{US,dB} = 1.5dB, then TxPwrAdj_{ER,dB} = 2 dB and TxPwrAdj_{OPP,dB} = 1 dB, and the minimum transmit power for NGPON2 10G upstream would be 4+2+1 = 7 dBm.

Pass/Fail Criteria:

Mean Channel Launch Power should be as indicated in G.989.2 and G.9807.1 for specified ODN Class.

7.2.2 ONU Extinction Ratio

Reference Documents:

- ITU-T G.987.2 Table 9-4
- ITU-T G.9807.1 Table B.9-4
- ITU-T G.989.2 Tables 11-6 and 11-7

Test Objective:

Verify that the ONU extinction ratio complies with the requirements defined in the

- XG-PON: table 9-4
- XGS-PON: G.9807.1 Table B.9-4
- NG-PON2: G.989.2 Tables 11-6 and 11-7

Test Setup:

- As shown in Section 5.5.2.

Pretest Conditions:

The ONU is powered and connected according to the test setup in Figure 2.

Test Procedure:

The extinction ratio shall meet the specifications when measured according to IEC 61820-2-2 with the port transmitting valid data per the ITU Standard and with minimal back reflections into the transmitter, lower than -20 dB. The test receiver has the frequency response as specified for the transmitter optical waveform measurement.

The amplitude histogram must be constructed accord one of two methods:

1. Method 1: Construct an amplitude histogram that includes all samples present on the logic one level within the central 20 % of the eye diagram unit interval. b_1 is the mean value of the histogram (see Figure 11). The center of the eye is defined as midway between the crossing times. The exact definition may be given by the governing standards; otherwise 0,5 UI from the mean crossing time is suitable. It is important that histogram means rather than peak values are used for the following reasons: Extinction ratio should be measured for the aggregate logic one and zero levels. Eye diagram pattern dependencies can result in distributions that are asymmetric and/or contain multiple modes. Also, if two or more modes dominate and are close in magnitude, the peak value may switch between modes as data is collected leading to an extinction ratio measurement that is unstable.
2. Similar to Method 1 construct an amplitude histogram that includes all samples present on the logic zero level within the central 20 % of the eye diagram unit interval. b_0 is the mean value of the histogram (see Figure 11).

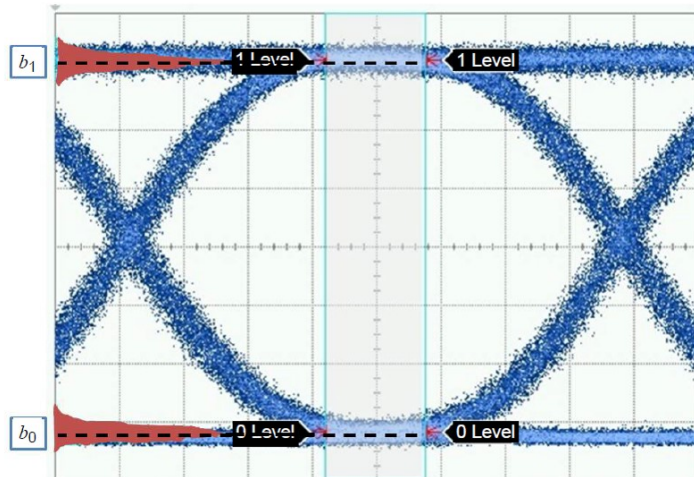

Figure 11 - Histograms centered in the central 20 % of the eye used to determine the mean logic one and 0 levels, b_1 and b_0

The extinction ratio is then calculated as follows:

- Extinction ratio (linear): $(b_1 - b_{\text{dark}}) / (b_0 - b_{\text{dark}})$
- Extinction ratio in decibels: $10 \log_{10}((b_1 - b_{\text{dark}}) / (b_0 - b_{\text{dark}}))$
- Extinction ratio as a percentage: $100 (b_0 - b_{\text{dark}}) / (b_1 - b_{\text{dark}})$

Pass/Fail Criteria:

The extinction ratio in decibels must be greater than or equal to the value given in the reference documents.

7.2.3 ONU Transmit optical waveform (transmit eye)

Reference Documents:

- ITU-T G.987.2 Figure 9-4, Table 9-6
- ITU-T G.989.2 [6], Figure 11-5, Table 11-9
- ITU-T G.9807.1 Table B.9-6, Figure B.9-4

Test Objective:

Verify that the ONU optical waveform complies with the requirements defined in the respective ITU-T PMD documents.

Test Setup:

- As shown in Section 5.2.1.

Pretest Conditions:

Many communications standards define the allowable shape of a transmitter output waveform through an eye mask. An eye mask typically consists of three polygons placed above, below, and within the eye-diagram (see Figure 13). Mask shapes are typically defined by specific communications standards. For example, XGS-PON and XG-PON have different eye diagram masks. The eye diagram and mask defined in the relevant standard should be used. The alignment of the mask to the eye diagram generally is as follows:

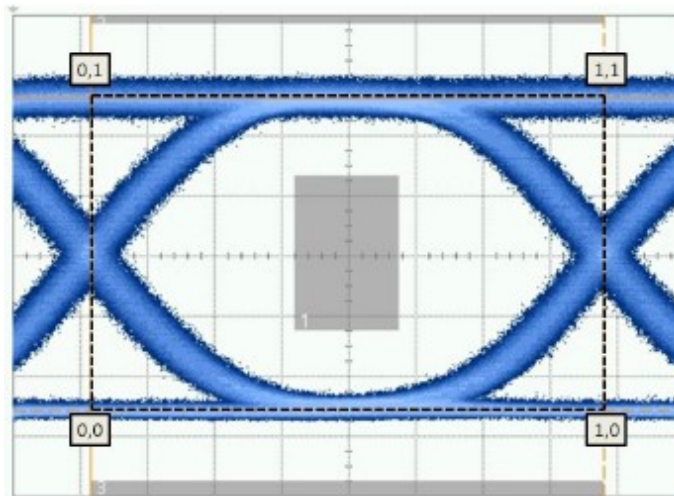

Figure 12 - Basic eye mask coordinate system

The mask shapes are defined using a generic coordinate system where 0 and 1 on the time axis correspond to the left and right crossing points of the eye respectively although in some standards it is permissible to adjust the position of the eye in time. 0 on the amplitude axis is defined by the logic zero level of the eye. 1 on the amplitude axis is defined by the logic one level of the eye. Unless stated otherwise by the communication standard the 1 and 0 amplitude levels are defined according to Section 8.8 as b_1 and b_0 respectively.

Mask tests are typically performed using digitizing oscilloscopes. A digitized waveform is composed of a fixed number of samples. Historically a transmitter with one or more samples falling on any mask polygon was considered non-complaint. Thus, results are dependent upon the population size of the sampled data. When a mask test is designed, the number of waveform samples required to produce an adequate assessment of the eye diagram, rather than the number of waveforms, should be considered. As the number of samples that make up a waveform can vary with different oscilloscope implementations, specifying a number of samples rather than waveforms will lead to comparable results. Typical values for the number of samples range from 50 000 to 1 000 000. It is important to note that the likelihood of mask test failures increases with increased sample size due to random elements such as noise and jitter in the signal and measurement equipment. For consistency in test results, the number of samples required for an adequate population should be set by the communication standard. The benefit of a large sample population is typically weak compared to the test time penalty incurred, thus populations in the 100 000 to 200 000 are recommended.

Mask test compliance can be quantified further through the use of mask margins to determine how well compliance is achieved. A positive mask margin is an expansion of the nominal mask while a negative margin is a contraction of the nominal mask. A mask margin is generally a proportional expansion of the mask polygons within the general coordinate system. A 0 % expansion represents the nominal mask dimension, while a 100 % mask expansion would be a mask that had been expanded to the 0 and 1 levels of the generic coordinate system. Note that a waveform with a 100 % mask margin is unrealizable when measured with a typical reference receiver using common eye mask shapes. The fastest rise and fall times that can pass through the reference receiver will still violate a 100 % mask expansion even if the transmitter is completely free of distortion, noise and jitter. A mask margin is generally not considered as part of a communications standard, as the standard defines the baseline capability required for system level communications performance. Mask margins are generally used for manufacturing process control and as a figure of merit for a transmitter design.

Test Configuration:

Configure the system as show in Section 5.2.1.

In general, an eye mask test that allows no mask hits is subject to inconsistent results. As indicated in 8.1, results are typically dependent on the population size. This is particularly true when mask margins are applied. A transmitter may easily achieve no hits for the standard test for even large sample sizes. When the mask dimensions are expanded for margin testing, the amount of expansion that can be achieved with no mask hits will fluctuate both from test to test as well as with different population sizes. A single sample that is a rare outlier in the overall population may significantly reduce the mask expansion in one test but not when a new sample population is acquired.

If a small percentage of samples are allowed to violate the mask compared to the total number of samples, mask testing is significantly less vulnerable to variation in results due to extreme outliers or changes in sample population size. For example, if 1 out of 10 000 samples are allowed to violate the mask, the mask margin will typically be the same for a sample population of 100 000, 1 000 000, or 10 000 000 samples. See Figure 14. The product of sample population and hit ratio should be greater than 5 for consistent results.

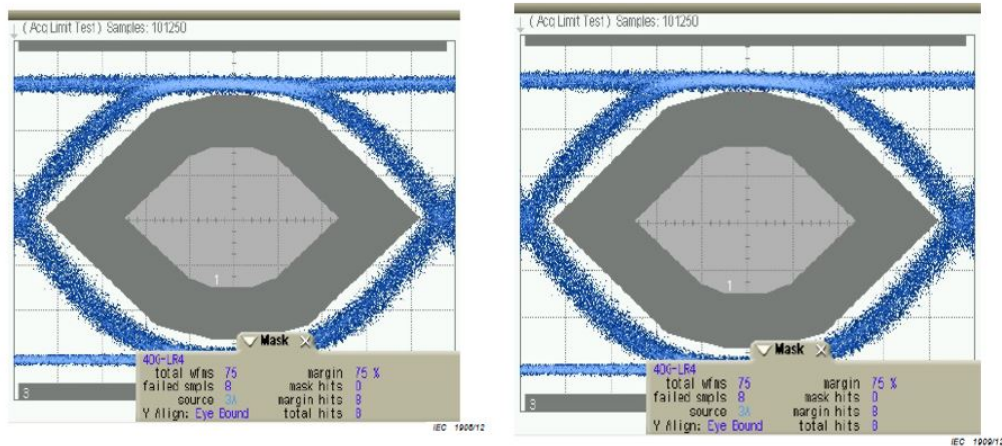

Figure 13- (left) Mask margin with ~ 100 000 samples tested at a 1:10 000 hit ratio: 75 %. (right) Mask margin (76 %) with over 1 million samples and a 1:10 000 hit ratio.

For a communication standard using the hit ratio technique, mask dimensions and allowable hit ratio shall be designed concurrently to be compatible with link budgets. A hit ratio of 5×10^5 is common and gives reasonable correlation to link performance.

Pass/Fail Criteria:

The eye mask values given in the reference documents must be met.

7.2.4 ONU Receive Sensitivity

Reference Documents:

- XG-PON: G.987.2 table 9-3
- XGS-PON: G.9807.1 Table B.9-3
- NG-PON2: G.989.2 Tables 11-4 and 11-5.

Note for XG-PON and XGS-PON, TWDM, PtP, and IBXT generators are not needed.

Test Objective:

Verify that the ONU receiver sensitivity complies with the requirements defined in the reference documents.

Test Setup:

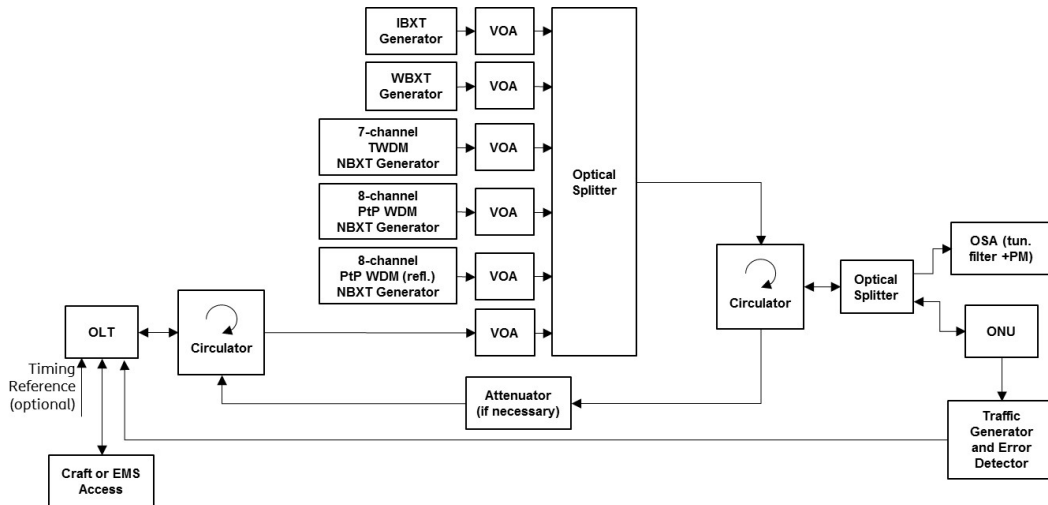

Figure 12.1 – Simplified Test Setup for ONU Receive Sensitivity

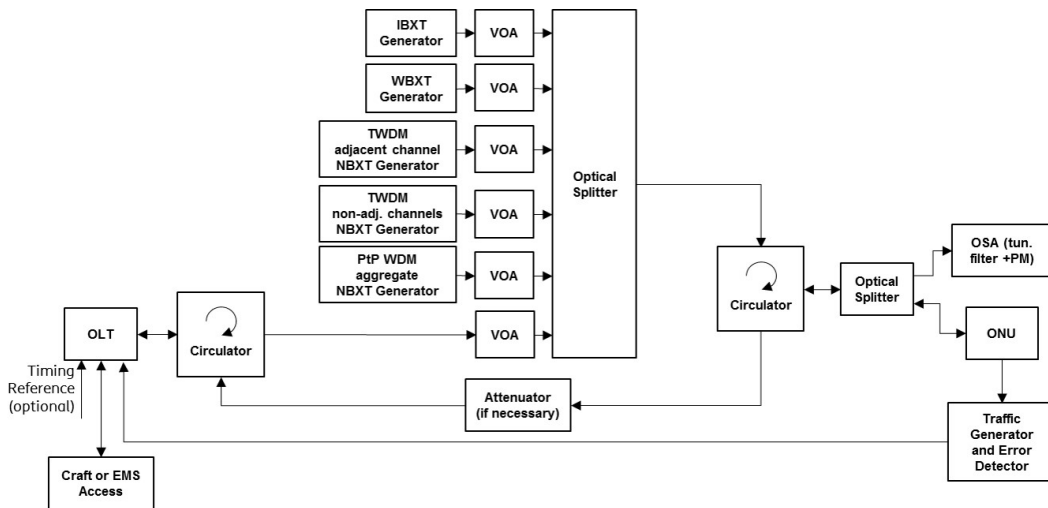

Figure 12.2– Simplified Test Setup for ONU Receive Sensitivity

Pretest Conditions:

The ONU is connected according to the test setup figure 12a or 12b for XG-PON and XGS-PON, TWDM, PtP, IBXT generators are not needed.

Receiver sensitivity is defined for a set of conditions: (1) a random data pattern, (2) input signal quality conforming to the required eye diagram (Section 8.10), (3) input signal quality conforming to the specified extinction ratio (Section 8.8), (4) wide-band, narrow-band, and in-band crosstalk, and (5) at a specific BER listed in the reference documents.

The optical transmitter of the OLT shown in Figure 12a and 12b must conform to appropriate requirements for test. The sampling or slicing point should be set by the ONU under test. Refer to the appropriate standards documents for parameters of wide-band crosstalk (WBXT), narrow-band crosstalk (NBXT), and in-band crosstalk (IBXT). NBXT and IBXT terms are applicable to NG-PON2 systems only. An OSA (or tunable filter with power meter) should be used to separately measure the power of the signal and interferers.

Figure 12b demonstrates a simplified setup where interferers may be aggregated to reduce the number of required optical sources. The allowed simplifications are as follows: (1) The 7 TWDM interferers may be reduced to the two nearest frequency channels with the power in the second channel equivalent to the sum of six channels; (2) The 4 or 8 PTP WDM interferers may be reduced to one PTP interferer in the nearest frequency slot with power equivalent to all channels.

NBXT interferers should be tuned to the wavelength specified in G.989.2 Table 10-1 and modulated by a pseudo-random pattern with the same or lower data rate as the signal under test. IBXT may be polarization-aligned or randomly polarized with respect to the signal under test. If IBXT is randomly polarized its power should be increased 3 dB relative to the reference polarization-aligned case.

Test Procedures:

Sensitivity is the minimum average received optical power that produces a specified bit error ratio reference level. For G.987.2, G.989.2 and G.9807.1, this reference level is the bit error ratio at the PMD layer prior to FEC decoding with FEC on, and therefore the bit error rate is relatively high (10^{-3} to 10^{-4}) and cannot be observed directly at the UNI and SNI interfaces. For this case, the reference bit error ratio level can be determined using either corrected FEC codewords or corrected FEC bytes.

Procedure 1 – PMD Layer pre-FEC BER

For measurement of sensitivity at the PMD layer prior to FEC decoding with FEC on (e.g. G.987.2, G.989.2 and G.9807.1):

1. Use the variable attenuators on each of the interferer branches to set the specified optical power.
2. Set the received optical signal power into the ONU RX with the variable optical attenuator on the signal branch.
3. Reset all error counters.
4. Make a bit error rate measurement with confidence level of at least 99.9%.
5. Record the received power and BER.
6. Return to step one until all BERs of interest have been measured.
7. Plot the recorded BER versus received power.
8. Perform a complimentary error function fit of the plotted data. Extract the received power which crosses the required BER
9. Set the received optical signal power into the ONU RX to the value determined in step 8.
10. Disconnect and reconnect the optical fiber. If the ONU fails to range or fails to meet the require BER, then increase the received optical signal power and repeat this step.
11. The receiver sensitivity is the smallest receive power value where the ONU is able to range and meets the required BER

Procedure 2 – End to End Sensitivity Estimation

For estimation of the sensitivity by observing the UNI and SNI interfaces:

1. Use the variable attenuators on each of the interferer branches to set the specified optical power

2. Set the received optical signal power into the ONU RX with the variable optical attenuator on the signal branch to a value close to expected sensitivity level.
3. Reset all error counters.
4. Measure the packet loss for 30 secs and record the received power and number of packets lost
5. If zero packet loss is achieved, increase the attenuation of the variable attenuator and return to step 3, until non-zero values are recorded.
6. Return to the attenuation level just before the packet loss.
7. Disconnect and reconnect the optical fiber and measure the packet loss for 30 secs. If the ONU fails to range or there are lost packets, then increase the received optical signal power and repeat this step, until ranging is successful.
8. Measure the packet loss with a zero-error confidence level of at least 99.9% and record the received power and number of packets lost. If there are lost packets, then increase the received optical signal power and return to step 7. The minimum number of bit intervals that must be observed with zero errors for a confidence level of 99.9% and bit error probability 10^{-12} is 6.91×10^{12} . For bit rate of 8.7 Gbps (the bit rate for 10Gbps PON after FEC decoding), this corresponds to observing zero packet loss in 794 seconds. See G.sup39 clause 9.4.
9. The received optical signal power is the estimate of the sensitivity value.\

Procedure 3 – ONU long term receive sensitivity verification

For verification of the long term sensitivity by observing the UNI and SNI interfaces with FEC on :

1. Launch traffic
2. Set the received optical power into the ONU RX to the sensitivity at BER reference level ($P_{\text{sensitivity}}$) as defined in G.987.2 Table 9-3 for XG-PON, G.9807.1 Table B.9-3 for XGS-PON and G.989.2 Tables 11-4, 11-5 for NG-PON2. Disconnect the optical fiber and verify if the ONU is able to range
3. Reset all error counters of the traffic analyzer
4. Test the ONU for 12 hours
5. Record power level every 1 minute, the power level must be in the range $P_{\text{sensitivity}}$ to $P_{\text{sensitivity}} + 0.5\text{dB}$, the $P_{\text{sensitivity}}$ power can be corrected during the test
6. Stop traffic and record packet loss
7. For NG-PON2 repeat 2-7 for all operating wavelengths (one channel at time)

Pass/Fail Criteria:

The sensitivity values given in the reference documents must be met.

7.2.5 Central ONU Wavelength Parameters Tests

Reference Documents:

- ITU-T G.987.2 Table 9-4 Operating wavelength
- ITU-T G.9807.1 Table B.9-4 Operating wavelength

Test Objective:

Verify that the ONU operating wavelength complies with the requirements defined in the

- XG-PON : ITU-T G.987.2 Table 9-4 Operating wavelength
- XGS-PON: G.9807.1 Table B.9-4 Operating wavelength

Test Setup:

Figure 3: Test Setup Central ONU Wavelength Parameters Tests

Pretest Conditions:

1. The OLT and ONU is powered and enabled according to the test setup in the diagram above.
2. Only one ONU unit can be connected to optical path. Upstream min. 1Gbit/s traffic must be aggregated by ONU.
3. The OSA should be set to a span bandwidth up to 150% of operating wavelength band and the highest spectral resolution.

Test Procedure:

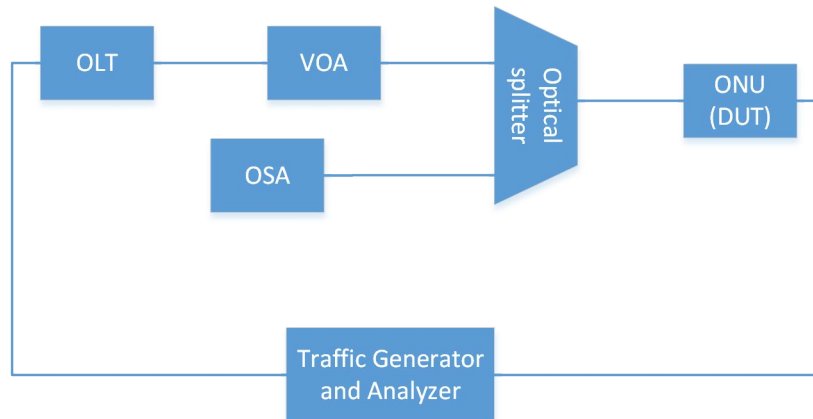
1. Enable the traffic on ONU
2. Warm up the setup – minimum 5 minutes
3. Start the wavelength measurement: test the optical signal every 1 minute for 1 hour

Pass/Fail Criteria:

For XG-PON: The ONU will pass if all the results are within the requirements defined in ITU-T G.987.2 Table 9-4 Operating wavelength.

For XGS-PON: The ONU will pass if all the results are within the requirements defined in ITU-T G.9807.1 Table B.9-4 Operating wavelength.

7.2.6 ONU Filtering

Reference Documents:

- ITU-T G.9807.1 Amendment 1 Figure B.10.1
- ITU-T G.987.2 Figure 10-1
- ITU-T G.989.2 Section 10.1.1 Wideband ONU Tolerance, Figure 10-1

Test Objective:

The test case verifies the out of band X/S tolerance of XG-PON, XGS-PON ONU and NG-PON2.

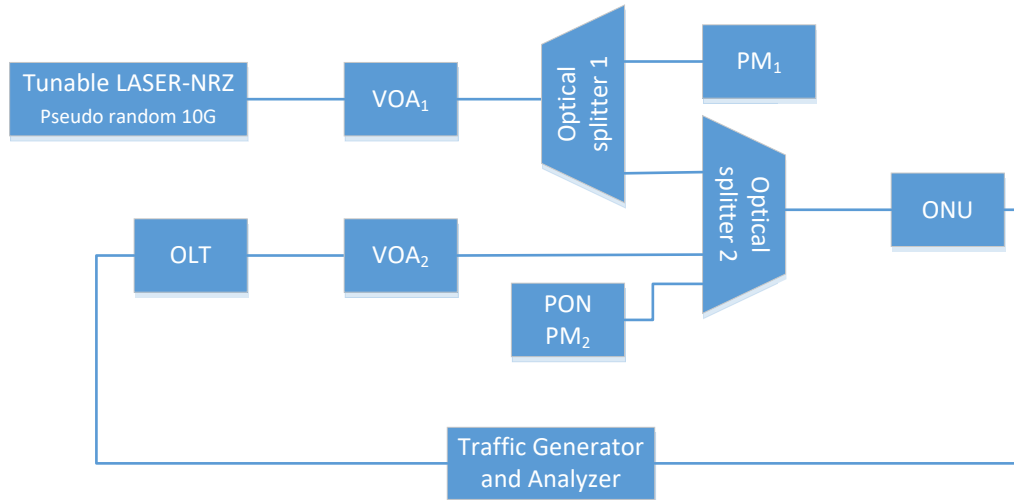
Test Setup:**Figure 4: Test Setup for XG(S)-PON ONU filtering****Pretest Conditions:**

1. ONU is powered and connected to ODN.
2. ONU has been activated by the OLT, has been ranged, and a GEM port for OMCI has been created as a result of ONU-ID assignment
3. Only 1 user traffic class should be configured at ONU (via defined OMCI messages below), requiring 1 GEM port (Alloc-ID, T-CONT, Port-ID).
4. The use of 10GE interface at the ONU XG-PON is recommended for the test
5. The Ethernet Traffic Generator should be configured to transmit Ethernet frames (maximization of the traffic load in downstream, and 1Mbit/s in upstream).
6. Calibrate the Optical Splitters to define the losses of each output branch

Test Procedure:

1. Launch traffic on the ONU
2. Set the received optical power into the ONU Rx at -28dBm and verify that no packet loss is observed.
3. Start LASER with a NRZ pseudo-random at 10Gbit/s @ 1260 nm. Note that LASER may be tunable as indicated in test setup figure or multiple tunable or fixed lasers may be used to generate interfering wavelengths.
4. Configure the VOA2 in order that X/S is 21.5dB. Stop traffic, clear all the counters and restart the traffic. Observe 5 minutes for packet loss in downstream.
5. For XG(S)-PON repeat 3-4 for following wavelengths: 1270 nm, 1310 nm, 1330 nm, 1490 nm, 1534 nm, 1550 nm, 1560 nm, 1596 nm, 1600 nm, 1625 nm, 1675 nm. For NG-PON2 repeat 3-4 for the following wavelengths: 1270 nm, 1310 nm, 1330 nm, 1490 nm, 1534 nm, 1550 nm, 1560 nm, 1581 nm, 1625 nm, 1675 nm.
6. For NG-PON2 repeat 1-5 for Channels 2-4.

Pass/Fail Criteria:

The test is passed if:

1. For all the tested wavelengths no packet loss is observed for an X/S ratio of 21.5dB

7.2.7 ONU Receive Overload

Reference Documents:

- XG-PON: G.987 Chapter 5.3
- XG-PON: ITU-T G.987.2 Table 9-3.
- XGS-PON: ITU-T G.9807.1 Table B.9-3 and Chapter 5.5
- NG-PON2: G.989 Chapter 5.5
- NG-PON2: ITU-T G.989.2 Tables 11-4, 11-5

Test Objective:

The test case verifies the ONU receiver meets overload requirements for given optical path loss class

Test Setup:

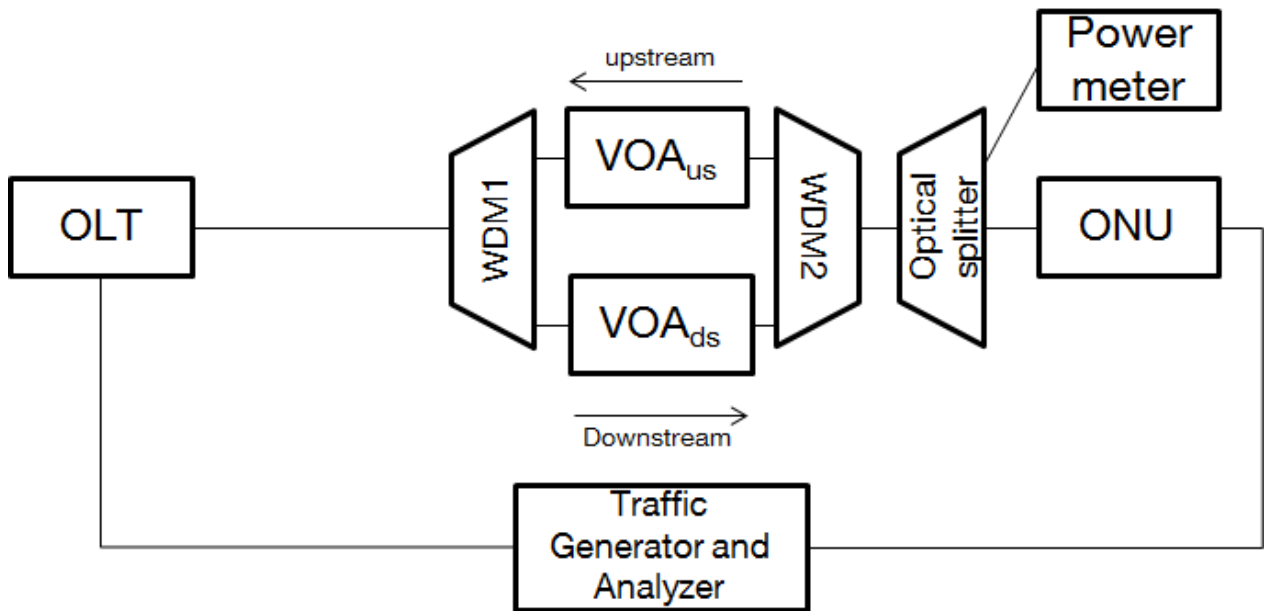

Figure 14: Test Setup for ONU Receive Overload

Pretest Conditions:

1. ONU is powered and connected to ODN.
2. ONU has been activated by the OLT, has been ranged, and a GEM port for OMCI has been created as a result of ONU-ID assignment
3. Only 1 user traffic class should be configured on the ONU (via defined OMCI messages below), requiring 1 GEM port (Alloc-ID, T-CONT, Port-ID).
4. The user of 10GE interface at the ONU is recommended for the test
5. The Ethernet Traffic Generator should be configured to transmit Ethernet frames (maximization of the traffic load in downstream, and 1Mbit/s in upstream).
6. Calibrate the Optical Splitter to define the losses of each output branch
7. Enable FEC

Test Procedure:

1. Launch traffic
2. Set the received optical power into the ONU RX to the Minimum overload at BER reference level (P_{overload}) as defined in G.987.2 Table 9-3 for XG-PON, G.9807.1 Table B.9-3 for XGS-PON and G.989.2 Tables 11-4, 11-5 for NG-PON2
3. Disconnect the optical fiber and verify if the ONU is able to range
4. Stop traffic, reset all error counters of the traffic analyzer and restart the traffic

5. Test the ONU for 12 hours
6. Record power level every 1 minute, the power level must be in the range $P_{\text{overload}} - 0.5\text{dB}$ and P_{overload} , the P_{overload} power can be corrected during the test
7. Stop traffic and record packet loss
8. For NG-PON2 repeat 2-7 for all operating wavelengths (one channel at time)

Pass/Fail Criteria:

1. ONU properly ranged after point 3
2. BER criteria for XG-PON: G.987 Chapter 5.3
3. BER criteria for XGS-PON: G.9807.1 Chapter 5.5
4. BER criteria for NG-PON2: G.989 Chapter 5.5

If direct BER measurement unavailable packet loss measurement should be used. 0 packet loss is expected.

7.2.8 ONU Side Mode Suppression Ratio Parameter Tests

Reference Documents:

- ITU-T G.987.2 Table 9-4 Minimum side mode suppression ratio
- ITU-T G.9807.1 Table B.9-4 Minimum side mode suppression ratio

Test Objective:

Verify that the ONU side mode suppression ratio complies with the requirements defined in the

- XG-PON : ITU-T G.987.2 Table 9-4 Minimum side mode suppression ratio
- XGS-PON: ITU-T G.9807.1 Table B.9-4 Minimum side mode suppression ratio

Test Setup:

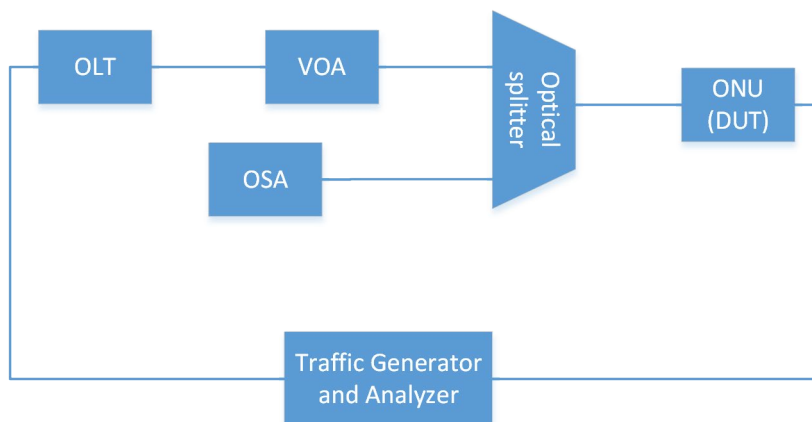

Figure 15: Test Setup Side Mode Suppression Ratio Parameter Tests

Pretest Conditions:

4. The OLT and ONU is powered and enabled according to the test setup in the diagram above.
5. Only one ONU unit can be connected to optical path. Upstream min. 1Gbit/s traffic must be aggregated by ONU.
6. The OSA should be set to a span bandwidth up to 150% of operating wavelength band and the highest spectral resolution.

Test Procedure:

1. Enable the traffic on ONU
2. Warm up the setup – minimum 5 minutes
3. Start the wavelength measurement: test the optical signal every 1 minute for 1 hour

Pass/Fail Criteria:

For XG-PON: The ONU will pass if all the results are within the requirements defined in ITU-T G.987.2 Table 9-4. Minimum side mode suppression ratio

For XGS-PON: The ONU will pass if all the results are within the requirements defined in ITU-T G.9807.1 Table B.9-4 Minimum side mode suppression ratio

7.2.9 ONU - Physical layer overhead time and launched optical power without input to the transmitter

Reference Documents:

- XGS-PON: ITU-T G.9807.1 Table B.III.2
- XG-PON: ITU-T G.987.2 Table III.2
- NG-PON2 : ITU-T G.989.2 Table III.2

Test Objective:

The test case verifies the Allocation of the physical layer overhead time meets standard expectations regarding guard time, preamble time and delimiter time. In addition, this test verifies that the launched optical power without input to the transmitter (designated When Not Enabled Power Spectral Density or WNE-PSD for G.989.2) does not exceed the limits of the recommendation.

Test Setup:

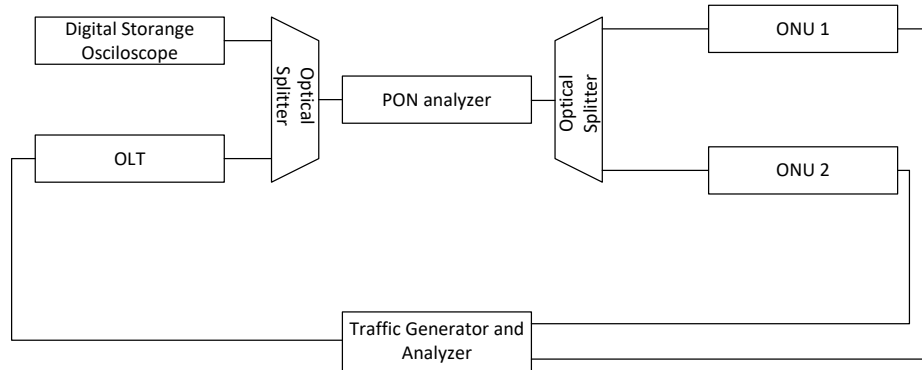

Figure 16:: Test Setup for Allocation of the physical layer overhead time and launched optical power without input to the transmitter

Pretest Conditions:

1. 2x ONUs are powered and connected to ODN.
2. ONUs have been activated by the OLT, have been ranged, and a GEM port for OMCI has been created as a result of ONU-ID assignment
3. Only 1 user traffic class should be configured on the each of ONUs (via defined OMCI messages below), requiring 1 GEM port (Alloc-ID, T-CONT, Port-ID).
4. Calibrate the Optical Splitters to define the losses of each output branch
5. The Ethernet Traffic Generator should be configured to transmit Ethernet frames (with the maximum available throughput in upstream on the ONUs – approximately 4 Gbit/s per ONU)
6. PON analyzer must be able to decode G.987.x, G.9807.x, G.989.x downstream messages
7. Enable FEC
8. Disable AES

Test Procedure:

1. Cause the Ethernet Traffic Generator to transmit bidirectional frames (1Mbit/s in downstream, and maximization of the traffic load in upstream)
2. Using digital storage oscilloscope record the burst for both ONUs
3. Determine the guard time length base on trace from oscilloscope
4. Determine the preamble pattern using data from PON analyzer
5. Using digital storage oscilloscope record the preamble
6. Using trace from oscilloscope confirm that preamble pattern transmitted by ONT is the same as determined in 4
7. Using trace from oscilloscope determine the preamble length
8. Determine the delimiter pattern using data from PON analyzer
9. Using digital storage oscilloscope record the delimiter
10. Using trace from oscilloscope confirm that delimiter pattern transmitted by ONT is the same as determined in 8.
11. Using trace from oscilloscope determine the delimiter length
12. Disable traffic for both ONUs, turn off ONU 2
13. Check whether the signal level sent by ONU1 during the quiet window meets standard expectation
14. Repeat 8-11 with disabled FEC

Pass/Fail Criteria:

1. None of the tested parameters exceed thresholds defined in:
 - a) XGS-PON: ITU-T G.9807.1 Table B.III.2

- b) XG-PON: ITU-T G.987.2 Table III.2
 - c) XG-PON: ITU-T G.987.2 Table III.2
2. Launched optical power without input to the transmitter (or WNE-PSD for G.989.2) does not exceed thresholds defined in :
- a) ITU-T G.9807.1 Table B.9.4
 - b) ITU-T G.987.2 Table 9.4
 - c) ITU-T G.989.2 Edition 2 Tables 11-6 and 11-7.

8 OLT PMD Tests

8.1 NG-PON2 Specific OLT PMD Layer Tests

8.1.1 OLT Out of Channel Power Spectral Density Compliance – OOC PSD

Reference Documents:

- ITU-T G.989.2 [6], Tables 11-4 and 11-5

Test Objective:

Verify that the OLT out of channel optical spectrum PSD complies with the requirements of G.989.2 tables 11-4 and 11-5.

Test Setup:



Figure 17 – Test Setup for OOC and OOB PSD

Discussion

While similar to the ONU OOC and OOB test procedures, the OLT procedure is much simpler. There is no need for a specialized burst spectrum analyzer (BSA) since the OLT is continuously sending data like a conventional transport laser. There is no burst induced spectral excursion as a result. Therefore, the test procedure does not have different duty cycle tests as the duty cycle of the OLT is always 100%, and a conventional OSA can be used.

Pretest Conditions:

The OLT or OLT optical module is powered and the transmitter is enabled according to the test setup in the diagram above. If the test is performed on the OLT module alone, there must be scrambled data transmitted according to the G.989.3 TC layer requirements.

The OSA should be set to a resolution bandwidth of 15 GHz or if not possible to a smaller resolution bandwidth and the results scaled to 15 GHz accordingly.

Test Procedure:

1. Enable the OLT to transmit continuous scrambled NRZ data.
2. Measure the Out of Channel PSD within the downstream TWDM band

Pass/Fail Criteria:

The OLT will pass if the OOC PSD is lower than the requirements in G.989.2 Tables 11-4 and 11-5.

8.1.2 OLT Out of Band Power Spectral Density Compliance – OOB PSD

Reference Documents:

- ITU-T G.989.2 [6], Tables 11-4 and 11-5

Test Objective:

Verify that the OLT out of band optical spectrum PSD complies with the requirements of G.989.2 tables 11-4 and 11-5.

Test Setup:

The same as the setup for the OLT OOC PSD

Pretest Conditions:

The same as the pretest conditions for the OLT OOC PSD

Test Procedure:

1. Enable the OLT to transmit continuous scrambled NRZ data.
2. Measure the Out of Band PSD over 1250nm to 1660nm excluding the TWDM downstream band.

Pass/Fail Criteria:

The OLT will pass if the OOB PSD is lower than the requirements in G.989.2 Tables 11-4 and 11-5.

8.2 General 10G-PON OLT PMD Layer Tests

8.2.1 OLT Transmit Power

Reference Documents:

- ITU-T G.987.2 Table 9-3
- ITU-T G.989.2 [6], Table 11-5
- ITU-T G.9807.1, Table B.9-3

Test Objective:

Verify that the OLT transmit power complies with the requirements of G.987, G.9807.1, G.989.2.

Test Setup:

As shown in diagram below. The OLT and ONU upstream power level can be measured by PON Power meters developed for field testing having the ability to be inserted between the OLT and ONU in a 'pass-through' mode to allow the system to operate while measuring signal levels both upstream and downstream.

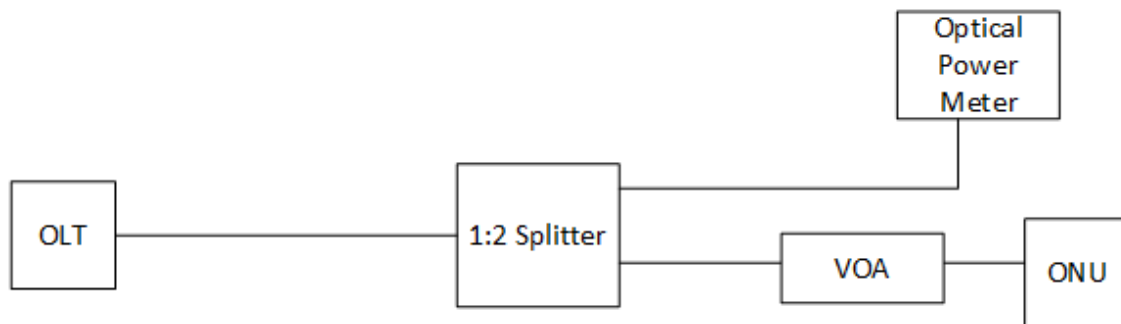

Figure 18 – Test Setup for OLT Transmit Power

Pretest Conditions:

The OLT and ONU are powered and connected according to the test setup in Figure 16.

Test Procedure:

1. Insert PON power meter using fiber jumper between OLT and optical splitter; at OLT end. The jumper should be between OLT and meter.
2. Record Upstream power reading.
3. Verify Mean Channel Launch Power is between levels indicated in G.987, G.989.2 and G.9807.1 for specified ODN Class.

Optical power shall meet specifications according to the methods specified in ANSI/EIA-455-95. A measurement may be made with the port transmitting any valid data stream.

Pass/Fail Criteria:

Mean Channel Launch Power should be between levels indicated in G.987, G.989.2 and G.9807.1 for specified ODN Class.

8.2.2 OLT Extinction Ratio

Reference Documents:

- ITU-T G.987.2 Table 9-3
- ITU-T G.989.2 [6], Tables 11-4 and 11-5
- ITU-T G.9807.1 Table B.9-3

Test Objective:

Verify that the OLT extinction ratio complies with the requirements of G.987.2 Table 9-3 G.989.2 tables 11-4 and 11-5 as well as G.9807.1 Table B.9-3.

Test Setup:

As shown in Section 5.2.1

Pretest Conditions:

The OLT is powered and connected according to the test setup in Figure 2.

Test Procedure:

Follow the procedure described in ONU section 7.8. The extinction ratio shall meet the specifications when measured according to IEC 61820-2-2 with the port transmitting valid data per the ITU Standard and with minimal back reflections into the transmitter, lower than -20 dB. The test receiver has the frequency response as specified for the transmitter optical waveform measurement.

8.2.3 OLT Receive Sensitivity

Reference Documents:

- ITU-T G.987.2 Table 9-4
- ITU-T G.9807.1 Tables B.9-4
- ITU-T G.989.2 [6], Tables 11-6 and 11-7

Note for XG-PON and XGS-PON, TWDM, PtP, and IBXT generators are not needed

Test Objective:

Verify that the OLT receive sensitivity complies with the requirements defined in the reference documents.

Test Setup:

As shown in Figure 17.

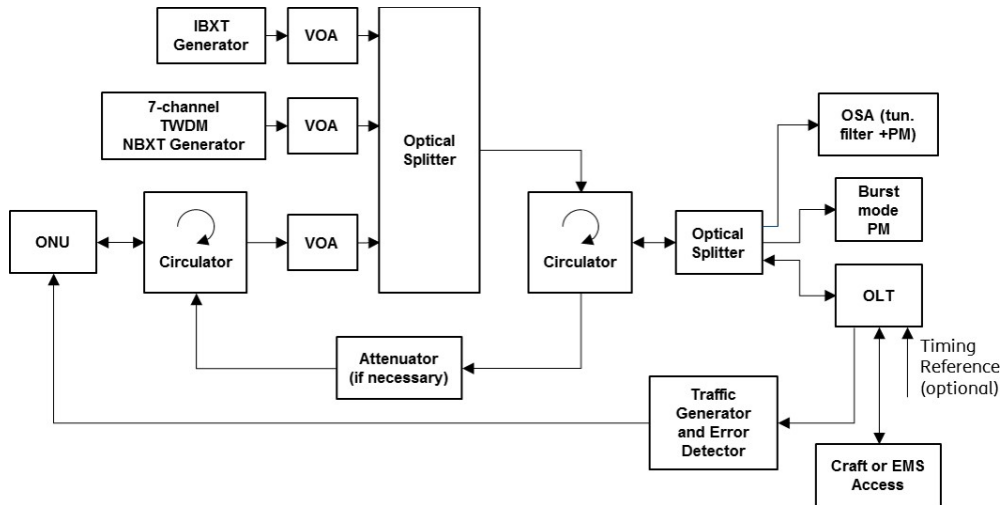

Figure 19– Test Setup for OLT Receive Sensitivity

Pretest Conditions:

The OLT and ONU are powered and connected according to the test setup in Figure 17. Note for XG-PON and XGS-PON, TWDM, PtP, and IBXT generators are not needed. The ONU transmitter should conform to the requirements in the reference documents. See section 7.9 for reference.

Simplifications of the crosstalk channels may be performed according to the descriptions in Section 7.9

Test Procedure:

Follow procedure described in ONU section 7.2.3, adapted for measuring OLT receive sensitivity. For NG-PON2 (TDMA) systems use the following adaptation for handling different extinction ratios from the ONU used in the test:

Sensitivity Adjustment for TWDM OLT Receivers: Ideally, the OLT is tested with a ‘golden’ ONU with an extinction ratio (ER) that is exactly 6dB. In practice it may be impossible to obtain an ONU with exactly 6dB, or close enough to 6dB that the deviation is negligible. G.989.2 amendment 2 allows extinction ratios (ER) above and below the nominal 6dB specified for ONUs. For ONUs with ERs that deviate substantially from 6dB the required OLT sensitivity will vary according to the formula in G.989.2 amendment 2. For example, the ONU is required to transmit at a 1dB higher Tx level than specified if it has a relaxed ER of 5dB rather than 6dB. In this case the required OLT sensitivity is 1dB less than in the specification.

Table 4 ONU extinction ratio and OLT sensitivity adjustment

ONU Extinction Ratio (dB)	8.0	6.0	5.0	4.0
OLT Sensitivity Adjustment (dB)	-1	0	+1	+3

For example, a sensitivity adjustment of -1dB means the OLT must be 1dB more sensitive than called out in G.989.2; if the sensitivity requirement was -26dBm, the adjusted requirement is -27dBm. For ERs that are between the numbers in the table, the sensitivity adjustment should be interpolated. For example, with an ER of 7.0dB, the sensitivity adjustment should be -0.5dB.

8.2.4 OLT Transmit optical waveform (transmit eye)

Reference Documents:

- ITU-T G.987.2 Table 9-5, Figure 9-2
- ITU-T G.989.2 [6], Figure 11-3, Tables 11-8
- ITU-T G.9807 Table B.9-5, Figure B.9-2

Test Objective:

Verify that the OLT optical waveform complies with the requirements defined in the respective ITU-T PMD documents.

Test Setup:

As shown in Section 5.2.1

Pretest Conditions:

Follow pretest conditions outline in Section 7.10.

Test Procedure:

Follow procedures outlined in Section 7.10.

8.2.5 OLT Receive Overload

Reference Documents:

- XG-PON: G.987 Chapter 5.3
- XG-PON: ITU-T G.987.2 Table 9-4.
- XGS-PON: ITU-T G.9807.1 Table B.9-4 and Chapter 5.5
- NG-PON2: G.989 Chapter 5.5
- NG-PON2: ITU-T G.989.2 Tables 11-6, 11-7

Test Objective:

The test case verifies the OLT receiver meets overload requirements for given optical path loss class

Test Setup:

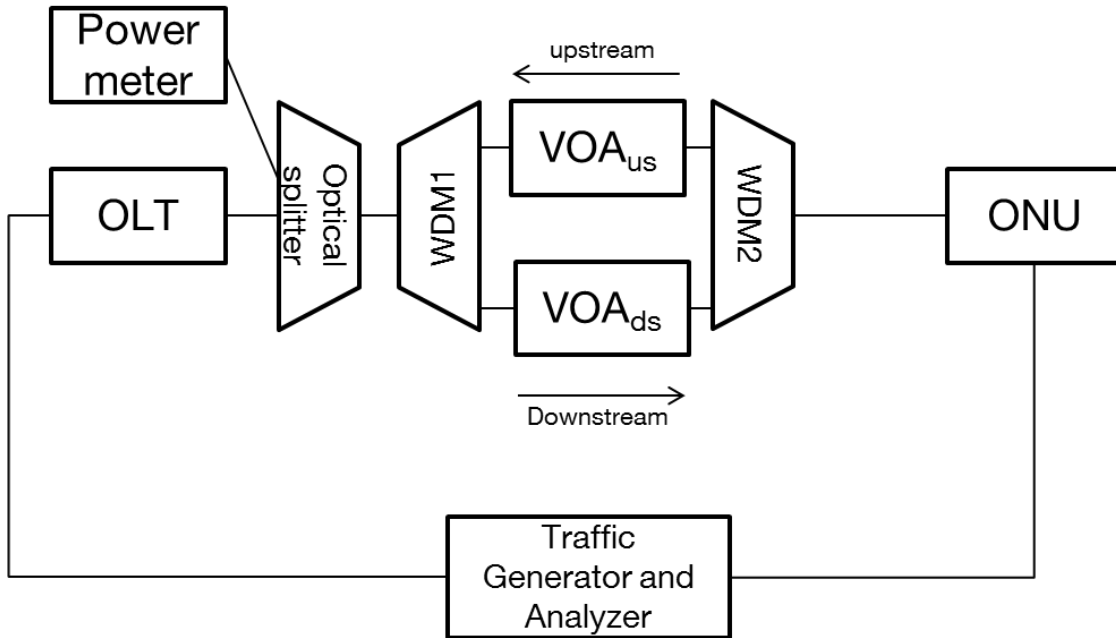

Figure 20: Test Setup for OLT Receive Overload

Pretest Conditions:

1. ONU is powered and connected to ODN.
2. ONU has been activated by the OLT, has been ranged, and a GEM port for OMCI has been created as a result of ONU-ID assignment
3. Only 1 user traffic class should be configured on the ONU (via defined OMCI messages below), requiring 1 GEM port (Alloc-ID, T-CONT, Port-ID).
4. The user of 10GE interface at the ONU is recommended for the test
5. The Ethernet Traffic Generator should be configured to transmit Ethernet frames (with the maximum available throughput in upstream on XG-PON and 1Mbit/s in downstream)
6. Calibrate the Optical Splitter to define the losses of each output branch
7. Burst signal Power meter must be used
8. Enable FEC

Test Procedure:

1. Launch traffic
2. Set the received optical power into the OLT RX to the Minimum overload at BER reference level ($P_{overload}$) as defined in G.987.2 Table 9-4 for XG-PON, G.9807.1 Table B.9-4 for XGS-PON and G.989.2 Tables 11-6, 11-7 for NG-PON2
3. Disconnect the optical fiber and verify if the ONU is able to range
4. Stop traffic, reset all error counters of the traffic analyzer and restart the traffic
5. Test the OLT for 12 hours
6. Record power level every 1 minute, the power level must be in the range $P_{overload} - 0.5\text{dB}$ and $P_{overload}$, the $P_{overload}$ power can be corrected during the test
7. Stop traffic and record packet loss
8. For NG-PON2 repeat 2-7 for all operating wavelengths (one channel at time)

Pass/Fail Criteria:

1. ONU properly ranged after point 3
2. BER criteria for XG-PON: G.987 Chapter 5.3
3. BER criteria for XGS-PON: G.9807.1 Chapter 5.5
4. BER criteria for NG-PON2: G.989 Chapter 5.5

If direct BER measurement unavailable packet loss measurement should be used. 0 packet loss is expected.

8.2.6 Central OLT Wavelength Parameters Tests

Reference Documents:

- ITU-T G.987.2 Table 9-3 Operating wavelength
- ITU-T G.9807.1 Table B.9-3 Operating wavelength

Test Objective:

Verify that the OLT operating wavelength complies with the requirements defined in the

- XG-PON : ITU-T G.987.2 Table 9-3
- XGS-PON: ITU-T G.9807.1 Table B.9-3

Test Setup:

- As shown in TR-423 Issue 1: Figure 14 Test Setup for OOC and OOB PSD

Pretest Conditions:

1. The OLT or OLT optical module is powered and the transmitter is enabled according to the Test Setup.
2. The OSA should be set to a span bandwidth of at least 150% of operating wavelength band and the highest spectral resolution.

Test Procedure:

1. Enable the OLT to transmit optical signal
2. Warm up the setup – minimum 5 minutes
3. Start the central wavelength measurement: test the optical signal every 1 minute for 1 hour

Pass/Fail Criteria:

For XG-PON: The OLT will pass if all the results are within the requirements defined in ITU-T G.987.2 Table 9-3 Operating wavelength.

For XGS-PON: The OLT will pass if all the results are within the requirements defined in ITU-T G.9807.1 Table B.9-3 Operating wavelength.

8.2.7 OLT Side Mode Suppression Ratio Parameter Tests

Reference Documents:

- ITU-T G.987.2 Table 9-3 Minimum side mode suppression ratio
- ITU-T G.9807.1 Table B.9-3 Minimum side mode suppression ratio

Test Objective:

Verify that the OLT minimum side mode suppression ratio complies with the requirements defined in the

- XG-PON : ITU-T G.987.2 Table 9-3 Minimum side mode suppression ratio
- XGS-PON: ITU-T G.9807.1 Table B.9-3 Minimum side mode suppression ratio

Test Setup:

- As shown in TR-423 Issue 1: Figure 14 Test Setup for OOC and OOB PSD

Pretest Conditions:

3. The OLT optical module is powered and the transmitter is enabled according to the Test Setup.
4. The OSA should be set to a span bandwidth of at least 150% of operating wavelength band and the highest spectral resolution.

Test Procedure:

1. Enable the OLT to transmit optical signal
2. Warm up the setup – minimum 5 minutes
3. Start the minimum side mode suppression ratio measurement: test the optical signal every 1 minute for 1 hour

Pass/Fail Criteria:

For XG-PON: The OLT will pass if all the results are within the requirements defined in ITU-T G.987.2 Table 9-3. Minimum side mode suppression ratio

For XGS-PON: The OLT will pass if all the results are within the requirements defined in ITU-T G.9807.1 Table B.9-3 Minimum side mode suppression ratio

8.2.8 OLT Receive Overload in dual rate operation

Reference Documents:

- XGS-PON: ITU-T G.9807.1 Table B.9-4 and Chapter 5.5

Test Objective:

The test case verifies the OLT receiver meets overload requirements for given optical path loss class in dual-rate operation

Test Setup:

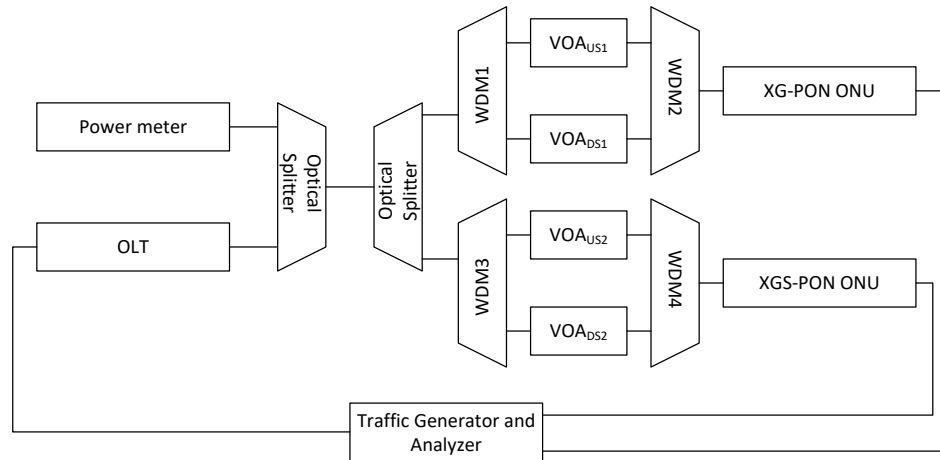

Figure 21: Test Setup for OLT Receive Overload in dual rate operations

Pretest Conditions:

1. ONUs is powered and connected to ODN.
2. ONU has been activated by the OLT, has been ranged, and a GEM port for OMCI has been created as a result of ONU-ID assignment
3. Only 1 user traffic class should be configured on the each of ONUs (via defined OMCI messages below), requiring 1 GEM port (Alloc-ID, T-CONT, Port-ID).
4. The user of 10GE interface at the ONU is recommended for the test
5. The Ethernet Traffic Generator should be configured to transmit Ethernet frames (1 Gbit/s for XG-PON ONU, 4 Gbit/s for XGS-PON ONU and 1Mbit/s in downstream for both cases)
6. Calibrate the Optical Splitters to define the losses of each output branch
7. Burst signal Power meter must be used
8. Enable FEC

Test Procedure:

1. Power on XG-PON ONU, power off XGS-PON ONU
2. Set the received optical power into the OLT RX to the Minimum overload at BER reference level minus 0.5 dB ($P_{\text{overload}} - 0.5 \text{ dB}$), P_{overload} as defined in G.9807.1 Table B.9-4
3. Power off XG-PON ONU, power on XGS-PON ONU
4. Set the received optical power into the OLT RX to the Minimum overload at BER reference level minus 0.5 dB ($P_{\text{overload}} - 0.5 \text{ dB}$), P_{overload} as defined in G.9807.1 Table B.9-4
5. Power on both ONUs
6. Disconnect the optical fiber and verify if the ONU is able to range
7. Reset all error counters of the traffic analyzer and start the traffic

8. Test the OLT for 12 hours
9. Stop traffic and record packet loss

Pass/Fail Criteria:

1. ONU properly ranged after point 3
2. BER criteria for XG-PON: G.987 Chapter 5.3 and BER criteria for XGS-PON: G.9807.1 Chapter 5.5 for overload level defined in G.9807.1 Table B.9-4 must be met
3. If direct BER measurement unavailable, packet loss measurement should be used. 0 packet loss is expected.

8.2.9 OLT Receive Sensitivity in dual rate operation

Reference Documents:

- XGS-PON: ITU-T G.9807.1 Table B.9-4 and Chapter 5.5

Test Objective:

The test case verifies the OLT receiver meets sensitivity requirements for given optical path loss class in dual-rate operation

Test Setup:

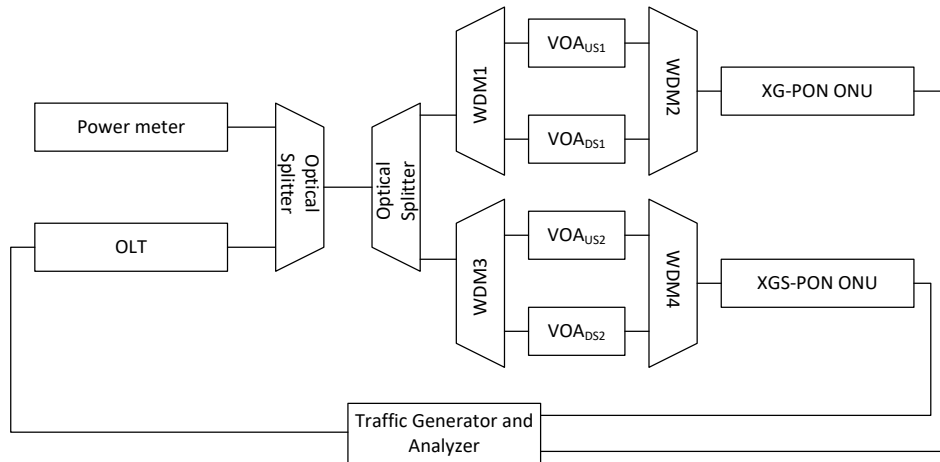

Figure 22: Test Setup for OLT Receive Sensitivity in dual rate operations

Pretest Conditions:

1. ONUs is powered and connected to ODN.
2. ONUs has been activated by the OLT, has been ranged, and a GEM port for OMCI has been created as a result of ONU-ID assignment
3. Only 1 user traffic class should be configured on the each of ONUs (via defined OMCI messages below), requiring 1 GEM port (Alloc-ID, T-CONT, Port-ID).
4. The user of 10GE interface at the ONU is recommended for the test
5. The Ethernet Traffic Generator should be configured to transmit Ethernet frames (1 Gbit/s for XG-PON ONU, 4 Gbit/s for XGS-PON ONU and 1Mbit/s in downstream for both cases)
6. Calibrate the Optical Splitters to define the losses of each output branch
7. Burst signal Power meter must be used

8. Enable FEC

Test Procedure:

1. Power on XG-PON ONU, power off XGS-PON ONU
2. Set the received optical power into the OLT RX to the Minimum overload at BER reference level plus 0.5 dB ($P_{\text{sensitivity}} - 0.5$ dB), $P_{\text{sensitivity}}$ as defined in G.9807.1 Table B.9-4
3. Power off XG-PON ONU, power on XGS-PON ONU
4. Set the received optical power into the OLT RX to the Minimum overload at BER reference level plus 0.5 dB ($P_{\text{sensitivity}} - 0.5$ dB), $P_{\text{sensitivity}}$ as defined in G.9807.1 Table B.9-4
5. Power on both ONUs
6. Disconnect the optical fiber and verify if the ONU is able to range
7. Reset all error counters of the traffic analyzer and start the traffic
8. Test the OLT for 12 hours
9. Stop traffic and record packet loss

Pass/Fail Criteria:

1. ONU properly ranged after point 3
2. BER criteria for XG-PON: G.987 Chapter 5.3 and BER criteria for XGS-PON: G.9807.1 Chapter 5.5 for sensitivity level defined in G.9807.1 Table B.9-4 must be met
3. If direct BER measurement unavailable, packet loss measurement should be used. 0 packet loss is expected.

9 WDM Coexistence Test Cases for XGS-PON with GPON

Reference Documents:

- ITU-T G.984.2
- ITU-T G.984.5
- ITU-T G.9807.1 Annex B

Test Objective:

Confirm the XGS-PON ONU is not impaired when a coexisting GPON signal is added to the ODN and the XGS-PON ONU Rx chain filters properly the GPON signal. Class B+ GPON and N1 XGS-PON are the primary focus, extensible to other optics classes.

Note: The Coexistence Test in Section 9 is duplicative to the ONU Receive Sensitivity Test in Section 7.2.3. Section 9 uses a G-PON system rather than a Test Set that emulates the downstream GPON optical signal using a WBTX Generator as shown in Figure 12 in Section 7.2.3 in the downstream direction. If the WBTX Generator has a tunable laser to test across the Band of 1480-1500 nm, the emulated approach would be better by setting the downstream GPON wavelength at 1500 nm, closer to the XGSPON wavelength from the OLT used in the test setup.

Pretest Conditions:

1. Check compliance of XGS-PON OLT laser to 1575-1581 nm wavelength band specified in ITU-T G.9807.1 Annex B Table B.9.3 using N1 optics measured using an Optical Spectrum Analyzer or equivalent test set.

2. Confirm compliance to GPON OLT Laser to the 1480-1500 nm wavelength band specified in ITU-T G.984.2 Am1 using Optical Spectrum Analyzer or equivalent test set.
3. The use of a CEx is used in the Test Diagram as referenced to Figure I.8 in Appendix I of ITU-T G.984.5 is shown. Alternative devices include a WDM1r device defined in ITU-T G.984.5 in Table I.5. can be used instead of a CEx

Test Setup:

A splitter size of 1x8 and use of 20 km of fiber cabling provides an end to end loss near 13 dB, sufficient dB of headroom to allow the GPON signal arrive at the XGS-PON ONU near the 13 dB minimum ODN loss.

The XGS-PON OLT and ONU are powered and connected according to the test setup in Figure 18 with the CEx connected as shown.

Connect the Traffic Generator to the XGS-PON OLT network interface and Error Detector test set to the XGS-PON ONU data UNI port.

Test Procedure:

1. Establish the XGS-PON OLT and ONU connection with Variable Optical Attenuator (VOA1) dialed to zero.
2. Vary VOA1 to set the XGS-PON OLT optical power level arriving at XGS-PON ONU to the ITU-T G.9807.1 AnnexB receiver sensitivity Downstream of -28dBm according to table B.9.3 budget class N1 initially by measuring with an optical power meter.
3. Confirm no errors are being detected on the downstream and upstream links for the XGS-PON system.
4. Connect GPON OLT port using a fiber patch cord to the CEx GPON port to add the GPON signal to the ODN with the coexisting XGS-PON link operating. Connect the GPON ONU to an output port of the 1xN PON splitter/coupler and turn up the GPON system.
5. Confirm the G-PON is error free in operation.
6. Confirm the XGS-PON downstream signal is error free with the traffic detector. Disconnect the XGS-PON ONU and record the optical power of the GPON signal arriving at the XGS-PON ONU. The worst case level of GPON would be at minimum ODN of 13 dB and max Tx level from the GPON OLT port. The power levels for Class B+ from the G-PON OLT are specified at +5 dBm to +1.5 dBm. GPON sensitivity is -27 dBm level at the G-PON ONT and the GPON minimum optical loss at 1490 nm is specified at 13 dB. Thus the worst case configuration is (+5 dBm – GPON min loss) = - 8dBm.
7. Vary the attenuator VOA2 to set the GPON power at the XGS-PON ONU to be -8 dBm to meet the worst case interfering power of GPON onto the XGS-PON ONU, this represents X/S value of -20 dB.
8. If no errors are induced onto XGS-PON downstream direction in the worst case condition of G-PON optical power expected, the XGS-PON ONU can Coexistent with GPON.

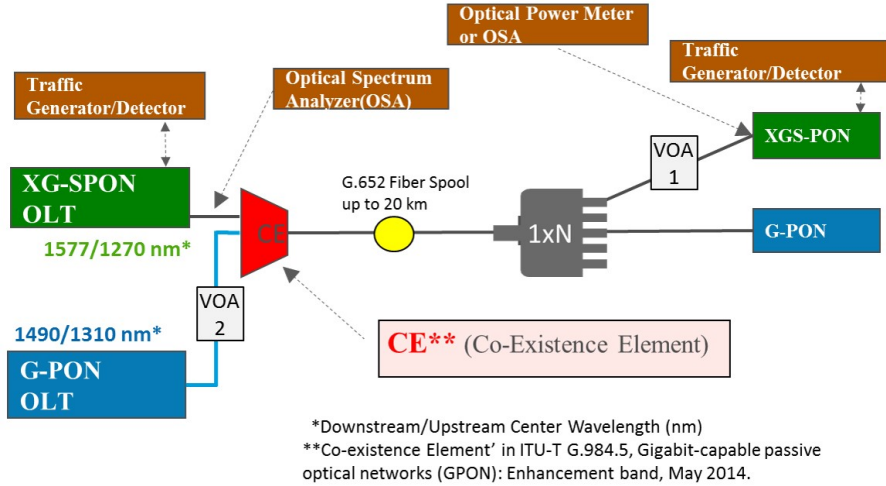

Figure 23 – Test Setup for XGS-PON ONU Coexistence with GPON

10 PON Optical Supervision Test Cases

Reference Documents:

- XGS-PON: ITU-T G.9807.1 Table B.II.1, chapter B.II.4
- XG-PON: ITU-T G.987.2 Appendix II
- XG-PON: ITU-T G.984.2 Amendment 2 Table IV.1/G.984.2, chapter IV.4
- ITU-T G.989.2 Edition 2 Appendix II

Test Objective:

The test case verifies the OLT and ONT meets standard expectations regarding resolution, accuracy and repeatability of OLT Rx Power (ONT), OLT Tx Power, ONT Rx Power, ONT Tx Power

Test Setup:

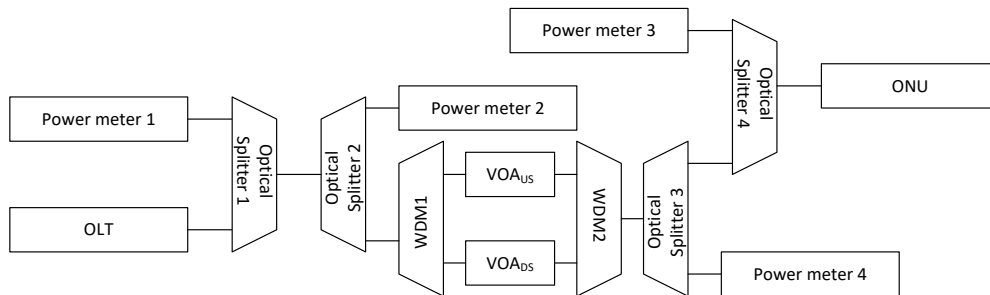

Figure 24: Test Setup for Optical supervision

Pretest Conditions:

1. ONU is powered and connected to ODN.
2. ONU has been activated by the OLT, has been ranged, and a GEM port for OMCI has been created as a result of ONU-ID assignment
3. Only 1 user traffic class should be configured on the each of ONUs (via defined OMCI messages below), requiring 1 GEM port (Alloc-ID, T-CONT, Port-ID).

4. FEC should be enabled in both directions for ONU
5. Calibrate the Optical Splitters to define the losses of each output branch
6. Power meter 1 and Power meter 3 must be burst signal power meter type

Terminology

- Overload Level is the maximum received power that the receiver will not overload as specified in the recommendations
- Maximum Level is the maximum level that the receiver can tolerate and the system remains ranged and it is stable enough to obtain readings from the DUT
- Sensitivity Level is the minimum received power that meets the bit error rate as specified in the recommendations
- Minimum Level is the actual minimum level that the receiver can tolerate and the system remains ranged and it is stable enough to obtain readings from the DUT

Test Procedure:

1. Power on ONU
2. Using VOA_{US} and VOA_{DS} set the OLT Rx Power and ONT Rx Power to Overload Level according to ITU-T G.9807.1 Tables: B.9-3, B.9-4 for XGS-PON or ITU-T G.987.2 Tables 9-3, 9-4 for XG-PON, and G.989.2 Edition 2 Tables 11-5, 11-6 and 11-7 for NG-PON2 if it is possible for given Tx Power. If Tx Power is too low to achieve Overload Level the minimum available attenuation should be set.
3. For 100 times, every 30 seconds read the following values:
 - a) Reference OLT Rx Power from Power meter 1 (including any non-uniformity from splitter)
 - b) OLT Rx Power from OLT
 - c) Reference OLT Tx Power from Power meter 2 (including offset for splitter)
 - d) OLT Tx Power from OLT
 - e) Reference ONT Rx Power from Power meter 3 (including any non-uniformity from splitter)
 - f) ONT Rx Power from OLT
 - g) Reference ONT Tx Power from Power meter 4 (including offset for splitter)
 - h) ONT Tx Power from OLT
4. Based on measurements: check resolution, accuracy and repeatability for OLT Rx Power, OLT Tx Power, ONT Rx Power, ONT Tx Power
5. Repeat 3-4 for OLT Rx Power and ONT Rx Power after adjusting VOA_{US} and VOA_{DS} to achieve:
6. Maximum Rx power level when ONU is able to range and upstream channel is stable enough to get readings from ONU (if possible, to achieve higher Rx Power level than in initial set-up)
7. Sensitivity Rx power level
8. Minimum Rx power level when ONU is able to range and upstream channel is stable enough to get readings from ONU. For minimum and maximum Rx power level typical ranges written in standard should not be exceed unless transceiver specification is different.
9. After attenuation change confirm that readings from OLT are valid for current set-up
10. Fill in table

Rx Power Level	Overload level			Maximum possible		Sensitivity Level		Minimum possible	
	Actual Resolution	Actual Accuracy	Actual Repeatability	Actual Accuracy	Actual Repeatability	Actual Accuracy	Actual Repeatability	Actual Accuracy	Actual Repeatability
OLT Tx Power									
OLT Rx Power									
ONT Tx									

Power									
ONT Rx Power									
Continuous monitoring	True / False (if false fill in the time required for OLT/ONU to refresh values after attenuation change)								

Pass/Fail Criteria:

1. Monitoring is done in continuous way
2. The DUTs Pass if none of the tested parameters exceed thresholds written in:
 - XGS-PON: ITU-T G.9807.1 Table B.II.1, chapter B.II.4
 - XG-PON: ITU-T G.984.2 Amendment 2 Table IV.1/G.984.2, chapter IV.4
 - ITU-T G.989.2 Edition 2 Appendix II depending on what type of PON system is being tested.

End of Broadband Forum Technical Report TR-423