

TR-419
**Fiber Access Extension over Existing Copper
Infrastructure**

Issue: 1
Issue Date: December 2020

Notice

The Broadband Forum is a non-profit corporation organized to create guidelines for broadband network system development and deployment. This Technical Report has been approved by members of the Forum. This Technical Report is subject to change. This Technical Report is owned and copyrighted by the Broadband Forum, and all rights are reserved. Portions of this Technical Report may be owned and/or copyrighted by Broadband Forum members.

Intellectual Property

Recipients of this Technical Report are requested to submit, with their comments, notification of any relevant patent claims or other intellectual property rights of which they may be aware that might be infringed by any implementation of this Technical Report, or use of any software code normatively referenced in this Technical Report, and to provide supporting documentation.

Terms of Use

1. License

Broadband Forum hereby grants you the right, without charge, on a perpetual, non-exclusive and worldwide basis, to utilize the Technical Report for the purpose of developing, making, having made, using, marketing, importing, offering to sell or license, and selling or licensing, and to otherwise distribute, products complying with the Technical Report, in all cases subject to the conditions set forth in this notice and any relevant patent and other intellectual property rights of third parties (which may include members of Broadband Forum). This license grant does not include the right to sublicense, modify or create derivative works based upon the Technical Report except to the extent this Technical Report includes text implementable in computer code, in which case your right under this License to create and modify derivative works is limited to modifying and creating derivative works of such code. For the avoidance of doubt, except as qualified by the preceding sentence, products implementing this Technical Report are not deemed to be derivative works of the Technical Report.

2. NO WARRANTIES

THIS TECHNICAL REPORT IS BEING OFFERED WITHOUT ANY WARRANTY WHATSOEVER, AND IN PARTICULAR, ANY WARRANTY OF NONINFRINGEMENT AND ANY IMPLIED WARRANTIES ARE EXPRESSLY DISCLAIMED. ANY USE OF THIS TECHNICAL REPORT SHALL BE MADE ENTIRELY AT THE USER'S OR IMPLEMENTER'S OWN RISK, AND NEITHER THE BROADBAND FORUM, NOR ANY OF ITS MEMBERS OR SUBMITTERS, SHALL HAVE ANY LIABILITY WHATSOEVER TO ANY USER, IMPLEMENTER, OR THIRD PARTY FOR ANY DAMAGES OF ANY NATURE WHATSOEVER, DIRECTLY OR INDIRECTLY, ARISING FROM THE USE OF THIS TECHNICAL REPORT, INCLUDING BUT NOT LIMITED TO, ANY CONSEQUENTIAL, SPECIAL, PUNITIVE, INCIDENTAL, AND INDIRECT DAMAGES.

3. THIRD PARTY RIGHTS

Without limiting the generality of Section 2 above, BROADBAND FORUM ASSUMES NO RESPONSIBILITY TO COMPILE, CONFIRM, UPDATE OR MAKE PUBLIC ANY THIRD PARTY ASSERTIONS OF PATENT OR OTHER INTELLECTUAL PROPERTY RIGHTS THAT MIGHT NOW OR IN THE FUTURE BE INFRINGED BY AN IMPLEMENTATION OF THE TECHNICAL REPORT IN ITS CURRENT, OR IN ANY FUTURE FORM. IF ANY SUCH RIGHTS ARE DESCRIBED ON THE TECHNICAL REPORT, BROADBAND FORUM TAKES NO POSITION AS TO THE VALIDITY OR INVALIDITY OF SUCH ASSERTIONS, OR THAT ALL SUCH ASSERTIONS THAT HAVE OR MAY BE MADE ARE SO LISTED.

All copies of this Technical Report (or any portion hereof) must include the notices, legends, and other provisions set forth on this page.

Issue History

Issue Number	Issue Date	Issue Editor	Changes
01	17 December 2020	Marcos Martínez Vázquez, MaxLinear Inc; Helge Tiainen, InCoax	Original

Comments or questions about this Broadband Forum Technical Report should be directed to info@broadband-forum.org.

Editor: Marcos Martínez, MaxLinear Inc
Helge Tiainen, InCoax

Work Area Director(s): Herman Verbueken, Nokia

Project Stream Leader(s): Aleksandra Kozarev, MaxLinear Inc

Table of Contents

Executive Summary	8
1 Purpose and Scope.....	9
1.1 Purpose	9
1.2 Scope	9
2 References and Terminology.....	10
2.1 Conventions.....	10
2.2 References	10
2.3 Definitions.....	11
2.4 Abbreviations	12
3 Technical Report Impact.....	15
3.1 Energy Efficiency	15
3.2 Security.....	15
3.3 Privacy.....	15
4 Fiber extension architecture	16
4.1 General architecture of a network with fiber extension	16
5 Fiber to the extension point deployment	18
5.1 Introduction	18
5.2 Main elements of FTTEp scenarios.....	18
6 FTTEp Use Cases and Deployment Scenarios	20
6.1 Use Cases Category 1a: Multi-tenant, with shared copper network outside the living unit	21
6.1.1 Use Case 1a-1 – “Point-to-Point data-grade twisted pair for HSIA in MDU”.....	21
6.1.2 Use Case 1a-2 – “Point-to-Point telco-grade twisted pair for HSIA in MDU”	21
6.1.3 Use Cases 1a-3/4/5 – “MDU Coaxial Cable Services” Use Cases.....	22
6.1.4 Use Case 1a-6 – “Multiple Point-to-Multipoint (M-P2MP) over existing indoor phone wiring”....	26
6.1.5 Use Cases 1a-7/8/9/10 – “Extending fiber services using copper to the distribution point – use cases”	28
6.1.6 Use Case 1a-11 – “Fiber extension by concatenating copper distribution networks (CDNs)- CuTTB”	32
6.1.7 Use Case 1a-12 – Fiber extension by concatenating copper distribution networks (CDNs)- multiple E2Es.....	33
6.1.8 Use Case 1a-13 – “Fiber extension by concatenating copper distribution networks (CDNs) - dual use pairs”.....	34
6.1.9 Use Case 1a-14 – “Copper to Fiber Backhaul migration”	36
6.2 Use cases Category 1b: Multi-tenant, with shared copper network and individual coaxial cable to the living unit.....	37
6.2.1 Use Case 1b-1 – “Point-to-Point Coaxial cabling with frequency diplexers for HSIA and satellite TV in MDU”.....	37
6.2.2 Use Case 1b-2 – “Point-to-Point Coaxial cabling for HSIA in MDU”.....	39
6.3 Use Cases Category 2: Exclusively-used cabling outside the living unit.....	39
6.3.1 Use Case 2-1 – “Single port Point-to-Point data-grade twisted pair or coaxial cabling”	39
6.3.2 Use Case 2-2 – “Multiple port Point-to-Point data-grade twisted pair or coaxial cabling”	41
Appendix I. FTTEp using technology MoCA Access.....	43
I.1 Introduction to MoCA Access Technology	43
I.2 Definitions.....	43

I.3	Abbreviations	43
I.4	References	44
I.5	Deployment models using MoCA Access technology.....	45
I.6	Requirements.....	45
I.7	Architectural and Topological Aspects	45
I.8	Environmental Aspects.....	46
I.9	Powering (and reverse powering).....	46
I.10	Physical interfaces	47
I.11	Northbound	47
I.12	Southbound	47
I.13	Traffic Management and QoS.....	47
I.14	VLAN Handling	47
I.15	Multicast	48
I.16	Ethernet OAM	48
I.17	Relay Agent and Intermediate Agent Operation.....	48
I.18	MoCA specific Type-Length-Values (TLVs)	50
I.19	Diagnostics	51
I.20	Network Management	51
I.21	EMA Concepts.....	52
I.22	O2E-EMA Discovery and NETCONF Session Establishment.....	53
I.23	Use of DHCP	53
I.24	O2E Identification.....	54
I.25	Initiation of NETCONF connection and O2E-EMA Authentication.....	54
I.26	Discovery Messages	55
I.27	EMA Offer Message.....	55
I.28	Discovery process.....	56
I.29	Management VLAN.....	57
I.30	Time management	57
I.31	EMA Aggregator	57
Appendix II. FTTEp using Gfast technology		59
II.1	Gfast introduction.....	59
II.1.1	<i>Key application features</i>	59
II.1.2	<i>Key functionalities and capabilities</i>	60
II.1.3	<i>Key performance aspects</i>	60
II.2	Definitions.....	61
II.3	Abbreviations	61
II.4	References	61
II.5	Deployment models using Gfast technology	62
II.6	Deployment model 1: Use case 1a-1 Point-to-Point data-grade twisted pair for HSIA in MDU	62
II.7	Deployment model 2: Use case 1a-2 Point-to-Point telco-grade twisted pair for HSIA in MDU.....	63
II.8	Deployment model 3: DPU stacking using cross-DPU vectoring	64
II.8.1	<i>Deployment configuration</i>	64
II.8.2	<i>Deployment management</i>	65
II.9	Deployment model 4: Use case 2-1/2-2 Single port/Multiport Point-to-Point data-grade twisted pair or coaxial cabling.....	65
II.10	Deployment model 5: Use case 1b-1 Point-to-Point Coaxial cabling with frequency diplexers for HSIA and satellite TV in MDU.....	66
II.11	Deployment model 5: Use case 1b-2 Point-to-Point Coaxial cabling for HSIA in MDU.....	67
Appendix III. FTTEp using G.hn Access technology.....		68
III.1	G.hn Access introduction.....	68
III.2	Definitions.....	69
III.3	Abbreviations	69
III.4	References	69
III.5	Deployment models using G.hn Access.....	70

III.5.1 Deployment model 1: Use case 2-1/2-2 Single port/Multiport Point-to-Point data-grade twisted pair or coaxial cabling.....70

Table of Figures

Figure 4-1: General architecture of a network with fiber extension16

Figure 4-2: Concatenation of CDNs.....17

Figure 5-1: Typical Single-Family Unit FTTEp deployment scenarios18

Figure 5-2: Typical Multi Dwelling Unit FTTEp deployment scenarios19

Figure 6-1: P2P data-grade twisted pair for HSIA in MDU - Generalized Use Case 1a-121

Figure 6-2: P2P telco-grade twisted pair for HSIA in MDU - Generalized Use Case 1a-222

Figure 6-3: Coaxial Cabling can co-exist with existing TV, Cable-TV or Satellite services by using different frequency bands in the coaxial network.....23

Figure 6-4: MDU Coaxial Cable services coexisting with the TV service - Generalized Use Case 1a-3.....24

Figure 6-5: MDU Coaxial Cable co-existing with the Cable-TV and DOCSIS services - Generalized Use Case 1a-4.....25

Figure 6-6: MDU Coaxial Cable services using full coaxial spectrum - Generalized Use Case 1a-526

Figure 6-7: M-P2MP over existing indoor phone wiring - Generalized Use Case 1a-627

Figure 6-8: Home, NTP and NTE connection.....28

Figure 6-9: MDU with in-building wiring29

Figure 6-10: MDU with operator adopted in-building wiring29

Figure 6-11: Extending fiber services using copper to the distribution point -Classic-No-RPF-Technician-Install - Generalized Use Case 1a-730

Figure 6-12: Extending fiber services using copper to the distribution point - RPF with VoIP re-injection, Self-Install - Generalized Use Case 1a-8.....31

Figure 6-13: Extending fiber services using copper to the distribution point - Classic-with-RPF Self-Install and derived POTS - Generalized Use Case 1a-9.....31

Figure 6-14: Extending fiber services using copper to the distribution point - P2MP, Self-Install - Generalized Use Case 1a-10.....32

Figure 6-15: Fiber extension by concatenating copper distribution networks (CDNs)- CuTTB – Generalized Use case 1a-1133

Figure 6-16: O2E backhaul using up to three sections of bonded copper lines - Use Case 1a-12.....34

Figure 6-17: High level architecture for the Use Case “Fiber extension by concatenating copper distribution networks (CDNs)- dual use pairs”36

Figure 6-18: Use case - Copper to Fiber backhaul migration.....37

Figure 6-19: P2P Coaxial with frequency diplexers for HSIA and satellite TV in MDU - Use Case 1b-138

Figure 6-20: P2P Coaxial cabling for HSIA in MDU - Generalized Use Case 1b-2.....39

Figure 6-21: Single port Point-to-Point data-grade twisted pair or coaxial cabling - Use case 2-140

Figure 6-22: Multiple port Point-to-Point data-grade twisted pair or coaxial cabling – Use case 2-241

Figure I-1: Typical deployment of MoCA Access where β in existing coaxial networks can be up to 100 meters45

Figure I-2:: MoCA Access can be deployed with P2MP or P2P topology from above FTTEp locations depending of existing coaxial network structure.....46

Figure I-3: MoCA Access management proxy model51

Figure I-4: TR-167 Management Domians with either P2MP virutal modem Ethernet or P2P modem Ethernet ports.....52

Figure I-5: TR-156 Management Domians with either P2MP virutal modem Ethernet or P2P modem Ethernet ports.....52

Figure II-1: P2P data-grade twisted pair for HSIA in MDU - Generalized Use Case 1a-162

Figure II-2: P2P telco-grade twisted pair for HSIA in MDU - Generalized Use Case 1a-263

Figure II-3: Mapping of deployment model 3 to Gfast technology.....64

Figure II-4: Mapping of use case 2-1 to Gfast technology65

Figure II-5: Mapping of use case 1b-1 to Gfast technology66

Figure II-6: Mapping of use case 1b-2 to Gfast technology67

Figure III-1: Mapping to G.hn Access of deployment model 171
 Figure III-2: Synchronization of GAMs in a mP2P scenario73
 Figure III-3: Use of elastic capacity in deployment model 174

Table of Tables

Table 6-1: Use Case 1a-121
 Table 6-2: Use Case 1a-221
 Table 6-3: Use Cases 1a-3/4/5.....22
 Table 6-4: Use Case 1a-626
 Table 6-5: Use Cases 1a-7/8/9/10/1128
 Table 6-6: Use Case 1a-1132
 Table 6-7: Use Case 1a-1233
 Table 6-8: Use Case 1a-1334
 Table 6-9: Use Case 1a-1436
 Table 6-10: Use Case 1b-137
 Table 6-11: Use Case 1b-239
 Table 6-12: Use Case 2-139
 Table 6-13: Use Case 2-241
 Table I-14: MoCA Access 2.5 technologies summary43
 Table I-1: MoCA Access Use Cases.....45
 Table I-2: MoCA specific TLVs50
 Table I-3: DHCPv6 and DHCP options used for O2E Discover message55
 Table I-4: TLVs for O2E Discover.....55
 Table I-5: TLVs for EMA Information56
 Table II-1: Summary of covered use cases.....62
 Table III-1: G.hn Access characteristics summary68
 Table III-2: Summary of covered use cases.....70
 Table III-3: Typical distance values.....72
 Table III-4: Recommended OFBs for this deployment model75

Executive Summary

Given the ever increasing demand for high speed services that are promised with fiber network technology there is a need for defining alternative and/or complementary architectures using metallic cables like twisted pair and coaxial cable for symmetric and asymmetric services in a more economical way than possible with fiber networks.

This Technical Report describes different ways of providing fiber-based access to customers by employing existing copper infrastructure to facilitate deployments in a more economically attractive way.

This can be achieved by extending the fiber network with the copper-based point-to-point P2P or point-to-multipoint P2MP infrastructure to provide Multi-Gigabit access into the home.

The overall architecture of a network with fiber extension is defined in Section 4 where the fiber is extended by using a copper medium without causing significant degradation in QoE compared to the FTTH.

Section 5 describes the main location features and principals of the Fiber To The extension point (FTTep) and the various deployment and migration options. The main objective of FTTep is to re-use existing copper or coaxial infrastructure to extend fiber gigabit services with minimal construction work.

As part of the initial FTTep architectural considerations, a large number of Use Cases were brought forward by different operators and vendors, describing the detailed functional requirements. The key points arising from the Use Case analysis are covered in Section 6.

In the appendixes, this Technical Report provides implementation guidelines for FTTep deployments with a focus on technology specific aspects of using different underlying technologies MoCA Access, Gfast and G.hn Access.

1 Purpose and Scope

1.1 Purpose

Demand for high data rates are continuously increasing and require both symmetrical and asymmetrical services. Competition on the broadband market is severe, which requires minimization of costs, increase speed of deployment and architectural approaches such as FTTEp to provide ultra-high-bit access into the home.

PON Fiber deployments in some brownfield's areas can have a number of barriers, such as lack of ducting both in-building and outside and in-building fiber ducts, opposition to new cabling in hallways / apartments and restrictions on building access to deploy fiber. There can also be doubts over or who should pay the in-building fiber deployment costs, the – building owner or service provider. To simplify deployments in such situations, this Technical Report is aimed to provide evidence of different possibilities to address barriers to broadband access by reusing the existing copper infrastructure.

This work has a number of operators Use Cases (UCs) of the Operators that highlights points of convergence in the Fiber-to-the-extension-point (FTTEp) architecture where the fiber is extended by using a copper medium without causing significant degradation in QoE compared to the FTTH.

This Technical Report leverages TR-301 Issue 2 on the FTTEp architecture and requirements, describing architectural, management and operational aspects of deployments that are common for to the above UCs, independently of the underlying copper technology used in the fiber access network extensions (MoCA, ITU-T G.hn, ITU-T G.fast or future ITU-T access technologies).

In the appendixes, this Technical Report includes the specificities of different underlying copper technologies for to the FTTEp deployments based on the described Use Cases.

1.2 Scope

This Technical Report describes a number of Use Cases (UCs) of what that could be considered as representative deployment needs of the Operators for extending fiber access over existing copper infrastructure with a Fiber-to-the-extension-point solution. The main focus is on the following aspects of the FTTEp solution:

- Architectural aspects:
 - Support of PON fiber access extension over P2P and P2MP topologies
 - Definition of interfaces (northbound and southbound) and functionalities to be implemented to comply with the requirements of the Use Cases
- Management aspects: Definition of the management infrastructure focused on Netconf/YANG
- Operational aspects, such as security, powering and maintenance, and parametrization (e.g., QoS settings) of the FTTEp solution to best fit the Use Case

In the appendixes, this Technical Report provides implementation guidelines for FTTEp deployments with a focus on technology specific aspects of using different underlying copper technologies.

2 References and Terminology

2.1 Conventions

In this Technical Report, several words are used to signify the requirements of the specification. These words are always capitalized. More information can be found in RFC 2119 [8].

MUST	This word, or the term “REQUIRED”, means that the definition is an absolute requirement of the specification.
MUST NOT	This phrase means that the definition is an absolute prohibition of the specification.
SHOULD	This word, or the term “RECOMMENDED”, means that there could exist valid reasons in particular circumstances to ignore this item, but the full implications need to be understood and carefully weighed before choosing a different course.
SHOULD NOT	This phrase, or the phrase “NOT RECOMMENDED” means that there could exist valid reasons in particular circumstances when the particular behavior is acceptable or even useful, but the full implications need to be understood and the case carefully weighed before implementing any behavior described with this label.
MAY	This word, or the term “OPTIONAL”, means that this item is one of an allowed set of alternatives. An implementation that does not include this option MUST be prepared to inter-operate with another implementation that does include the option.

2.2 References

The following references are of relevance to this Technical Report. At the time of publication, the editions indicated were valid. All references are subject to revision; users of this Technical Report are therefore encouraged to investigate the possibility of applying the most recent edition of the references listed below.

A list of currently valid Broadband Forum Technical Reports is published at www.broadband-forum.org.

Document	Title	Source	Year
[1] TR-301 Issue 2 Amendment 1	Architecture and Requirements for Fiber to the Distribution Point	BBF	2020
[2] G.984 series	<i>Gigabit-capable Passive Optical Networks (G-PON)</i>	ITU-T	2008
[3] G.987 series	<i>10 Gigabit-capable Passive Optical Networks (XG-PON)</i>	ITU-T	2012
[4] G.9807 series	<i>10 Gigabit-capable Symmetric Passive Optical Networks (XGS-PON)</i>	ITU-T	2016
[5] G.989 series	<i>40-Gigabit-capable passive optical networks (NG-PON2)</i>	ITU-T	2015
[6] TR-069	<i>CPE WAN Management Protocol</i>	BBF	2018
[7] TR-369	<i>User Services Platform (USP)</i>	BBF	2018
[8] RFC 2119	<i>Key words for use in RFCs to Indicate Requirement Levels</i>	IETF	1997

2.3 Definitions

The following terminology is used throughout this Technical Report.

Backhaul	In a hierarchical telecommunications network, the backhaul portion of the network comprises the intermediate links between the core network, or backbone network, and the small subnetworks at the edge of the network.
Copper	Copper as used in TR-301 [1] is defined as any wire for telephone, Cable TV or Ethernet that may be used for point to point communications or point-to-multipoint. It includes but is not limited to the following: <ul style="list-style-type: none"> • Twisted pair cable: Unshielded Twisted Pair (UTP) cables that includes legacy telephony wiring, Category 3, Category 5/5e and Category 6 twisted wiring • Coaxial cable
Copper Backhaul	In the generalized architecture described in this Technical Report, the copper backhaul section is an extension of the O2E entity toward the the Network Termination Point (NTP), and a Home Distribution Network (HDN). Also known as a Copper Distribution Network (CDN).
Extension point	A point where the optical fiber is terminated, and the optical signal is converted into an electrical signal for transmission over a copper medium to the NTE
FTTep	Architecture where the fiber is extended by using a copper medium without causing significant degradation in QoE compared to the FTTH
Gfast	Broadband Forum's name for the gigabit broadband access technology G.fast specified by ITU-T Recommendations G.9700 and G.9701
G.hn Access	Use of G.hn technology based on ITU-T Recommendations G.996x in broadband access applications, like FTTep.
G-PON	In the ITU-T series of Recommendations prior to ITU-T G.987, the term G-PON refers to a Gigabit-capable Passive Optical Network (PON) system supporting transmission rates in excess of 1.0 Gbit/s in at least one direction, and implementing the suite of protocols specified in the ITU-T G.984.x series Recommendations. However, the introduction of active network elements, e.g., reach extenders, called for a revision of the PON term's scope and usage because a G-PON system may not be entirely passive.
HDN	Home Distribution Network refers to an in-home (SFU) or an in-building (MDU) copper network for distribution of services to End User Devices (EUDs).
Legacy DSL	Widely used term to describe the ITU-T ADSL2 (Asymmetric digital subscriber line transceivers 2) and VDSL2 (Very high speed digital subscriber line transceivers 2) technologies for transmitting digital information at a high bandwidth on existing copper telephone lines.
Living Unit	An apartment or house for use by one family corresponding to exactly one customer
MoCA Access	Access network technology defined in MoCA Access 2.5 specification that is designed to operate on the existing coaxial plants found in residential and commercial buildings and adapt to the associated channel characteristics
Multiswitch	Multiswitch is a device used to distribute satellite TV signals to multiple receivers from a single dish and LNB.
Multi-tenant	Deployment model where one or more living units use a shared copper network. Note - MDU is a sub-case of a multi-tenant
NG-PON	In the context of the current ITU-T standards development activity, a generic term referencing the next generation (NG-) PON, a system evolution beyond G-PON. Also used as a generic term referencing NG-PON1 and NG-PON2.
NG-PON1	A PON system with a nominal aggregate capacity of 10 Gbit/s in the downstream direction. The NG-PON1 system is represented by XG-PON specified in the ITU-T G.987 series of Recommendations. The 10/10G option is defined under the XGS-PON ITU-T G.9807 series of Recommendations.

NG-PON2	A PON system with a nominal aggregate capacity of 40 Gbit/s in the downstream direction and 10 Gbit/s in the upstream direction, and implementing the suite of protocols specified in the ITU-T G.989 series Recommendations.
ODN	In the context of the current ITU-T standards development activity, an Optical Distribution Network (ODN) is defined as a point-to-multipoint optical fiber infrastructure that interconnects the OLT and the ONUs to form a PON system, which is not required to be entirely passive.
OLT	In the context of the current ITU-T standards development activity, an Optical Line Termination (OLT) refers to a network element in an ODN-based optical access network that terminates the common part of at least one ODN and provides an Optical Access Network (OAN) Service Node Interface (SNI).
ONU	In the context of the current ITU-T standards development activity, an Optical Network Unit (ONU) refers to a network element in an ODN-based optical access network that terminates a leaf of the ODN and provides an Optical Access Network (OAN) User Network Interface (UNI), irrespectively of the number and type of user interfaces or the depth of fiber deployment. In the context of the ITU-T standards, the term ONU is used generically to refer to any device terminating a leaf of the ODN. In the context of this Technical Report, the term ONU encompasses both a "multiple subscriber device" as well as a "single subscriber device".
ONT	Historically, the term Optical Network Terminal/termination (ONT) has been used either interchangeably with ONU or for "a single subscriber ONU". Note, however, that while this definition captures one established trade interpretation of the term, the concept itself is not used as a part of the G.987-series and ITU-T G.989-series scope reference access architecture. Outside of the scope of these ITU-T Recommendations, alternative interpretations may apply. This Technical Report uses a generic term ONU. An ONT is a special case of an ONU.
PON	In the context of the current ITU-T standards development activity, and this Technical Report, the term PON is used as a generic term referencing a system, that is, a combination of network elements including at least one OLT and multiple ONUs interconnected by an ODN that implements a particular coordinated suite of physical medium dependent layer, transmission convergence layer and management protocols.
Shared copper network	In-building/indoor copper network using shared cable, bundles of cables or individual cables in a shared conduit
Single-tenant	Deployment model where only one living unit is considered (e.g., no interaction with other living units)

2.4 Abbreviations

This Technical Report uses the following abbreviations:

ATA	Analog Telephone Adapter
BCN	Building Copper Network
BG	Bonding Group
CDN	Copper Distribution Network
CPE	Customer Premises Equipment
CuTTB	Copper To The Building
DCU	DSLAM cabinet unit
DECT	Digital Enhanced Cordless Telecommunications

DOCSIS	Data Over Cable Service Interface Specification
DPX	Diplexer
DS	Downstream
DSM	Dynamic Spectrum Management
E2E	Electrical-to-Electrical Entity
EP	Extension point
EUD	End User Device
FEXT	Far end cross talk
FH	FrontHaul
FTTB	Fiber To The Building
FTTH	Fiber To The Home
FTTep	Fiber-to-the-extension-point
HDN	Home Distribution Network
HSIA	High Speed Internet Access
LAN	Local Area Network
LNB	Low Noise Block downconverter
MAC	Medium Access Control
MDU	Multiple Dwelling Unit
M-P2MP	Multiple Point-to-multipoint
NHE	Network Head End
NEXT	Near End Crosstalk
NTE	Network Termination Entity
NTP	Network Termination Point
O2E	Optical-to-Electrical Entity (e.g., DPU per TR-301 [1] or NHE)
OAM	Operations, Administration, and Maintenance
ODN	Optical Distribution Network
OLT	Optical Line Termination
ONT	Optical Network Termination
ONU	Optical Network Unit
OTT	Over-the-Top content
P2P	Point-to-point
P2MP	Point-to-multipoint
PLC	Power-Line Communication
PON	Passive Optical Network
RAN	Radio Access Network
RGW	Residential Gateway
RPF	Reverse Power Feed or reverse powering of the remote access equipment
SFP	Small Form-factor Pluggable
SFU	Single Family Unit
TDD	Time Division Duplex
TR	Transceiver

US	Upstream
VoIP	Voice over IP (Internet telephony)

3 Technical Report Impact

3.1 Energy Efficiency

TR-419 has no impact on energy efficiency.

3.2 Security

TR-419 has no impact on security.

3.3 Privacy

TR-419 has no impact on privacy.

4 Fiber extension architecture

This section describes and defines the different elements that are used in a fiber extension architecture. The final naming of this element is technology-dependent, however, in order to provide consistency in this study document, we define some general terminologies and a general architecture of an optical network with fiber extension.

This general architecture is a generalization of the different use cases and does not preclude any type of technology or deployment approach (e.g., P2P/P2MP)

4.1 General architecture of a network with fiber extension

The general architecture of a network with fiber extension is shown in Figure 4-1

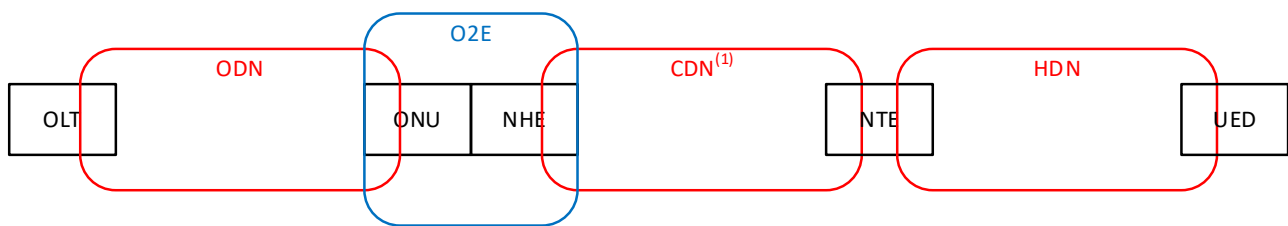

(1) CDN can also be a concatenation of CDNs

BBF_1

Figure 4-1: General architecture of a network with fiber extension

The overall network is composed of three sub-networks:

- **Optical Distribution Network (ODN):** This sub-network is composed of an optical distribution system (e.g., PON) and connects to the core network through the OLT.
- **Copper Distribution Network (CDN):** This sub-network is built using a copper-based technology for the physical layer (e.g., xDSL, G.hn, MoCA) and is used to get the signal delivered from the optical sub-network to the premises. The length and type of this CDN depends on the use case. CDN can also be a concatenation of one or more CDNs as shown in Figure 4-2.
- **Home Distribution Network (HDN):** This sub-network delivers the signal received from the CDN through the premises using the appropriate technology (e.g., Wi-Fi or a mix of in-home technologies). Note that in some of the use cases this HDN is merged with the CDN.

The following entities are used in this general architecture:

- **Optical Line Termination (OLT):** The OLT makes the transition between the core network and the ODN.
- **Optical Network Unit (ONU):** The ONU terminates the optical connection.
- **Network Head End (NHE):** The NHE receives the signal from the ONU and injects the traffic into the CDN(s). There may be a single port NHE, a multiport NHE, or several single-port NHEs with the appropriate routing functions, depending on the use case.
- **Network Termination Entity (NTE):** The NTE terminates the CDN. There is usually an NTE per household. The NTE transfers the traffic to the HDN, including sometimes a residential gateway (RGW) functionality. Multiple NTEs can be connected to the CDN.
- **End User Device (EUD):** EUDs terminate the communication flows within the premises (e.g., tablets, mobile phones, STBs). EUDs are normally owned by the user. Multiple EUDs can be connected to the HDN.

- **Optical to Electrical (O2E):** The O2E is an entity that does the conversion between the ODN and the CDN. The location of this entity is use case-dependent.
- **Electrical to Electrical (E2E):** The E2E is an entity that concatenates copper CDNs. The E2E may serve customer NTE directly and/or feed successive E2E in tandem. The E2E may aggregate capacity from multiple lines.

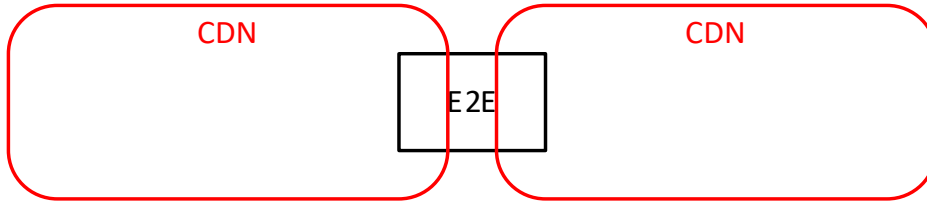

BBF_23

Figure 4-2: Concatenation of CDNs

5 Fiber to the extension point deployment

5.1 Introduction

This section describes the main location features and principals of FTTEp and the various deployment and migration options.

The main objective of FTTEp is to re-use existing copper infrastructure to extend fiber gigabit services with minimal construction work. The FTTEp can be located either outside or inside the building. Locating a new, high-speed access node at the Extension Point (EP) and reusing the existing copper passive networks has several advantages over FTTH, namely:

- It avoids the need to install new infrastructure into and around the home, i.e., there is no need to install a new FTTH fiber cable, or drill a hole in an external wall to take the fiber into the SFU, or install fiber within the MDU hallways and drill hole to each apartment to reach the ONU.
- By re-using either the copper infrastructure inside or outside the building provides higher flexibility and reduces the time between receiving and being able to fulfill a customer order.
- It can provide multi-gigabit services for both residential and business customers
- It allows customer self-install which removes the need for a visit to the customer premises with its attendant cost, time and logistical downsides.

As part of the initial FTTEp architectural considerations, Use Cases were brought forward by different operators and vendors.. The key points arising from a Use Case analysis are covered in Section 6.

5.2 Main elements of FTTEp scenarios

FTTEp is typically deployed near the end-user either outside or inside the building depending of available copper infrastructure. Some examples of of positioning of extension points are shown in Figure 5-1 and Figure 5-2 covering SFU and MDU buildings.

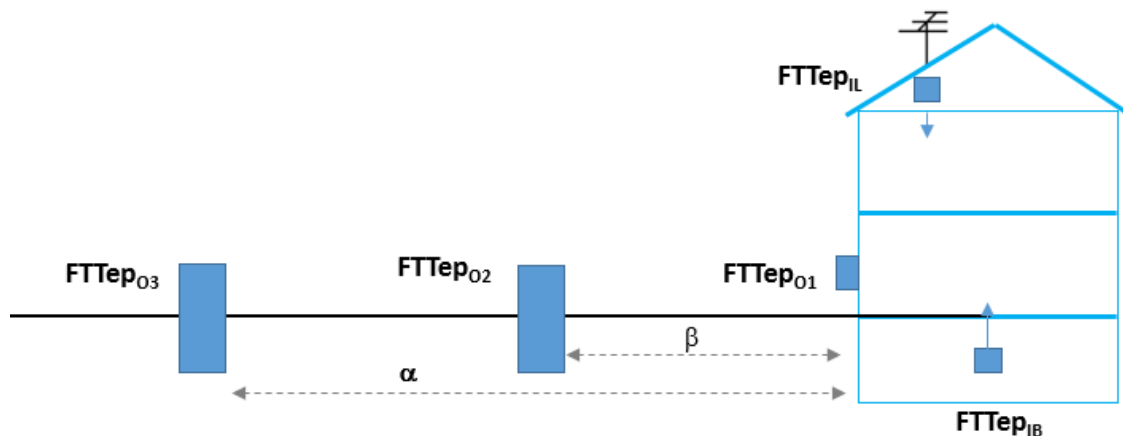

Figure 5-1: Typical Single-Family Unit FTTEp deployment scenarios

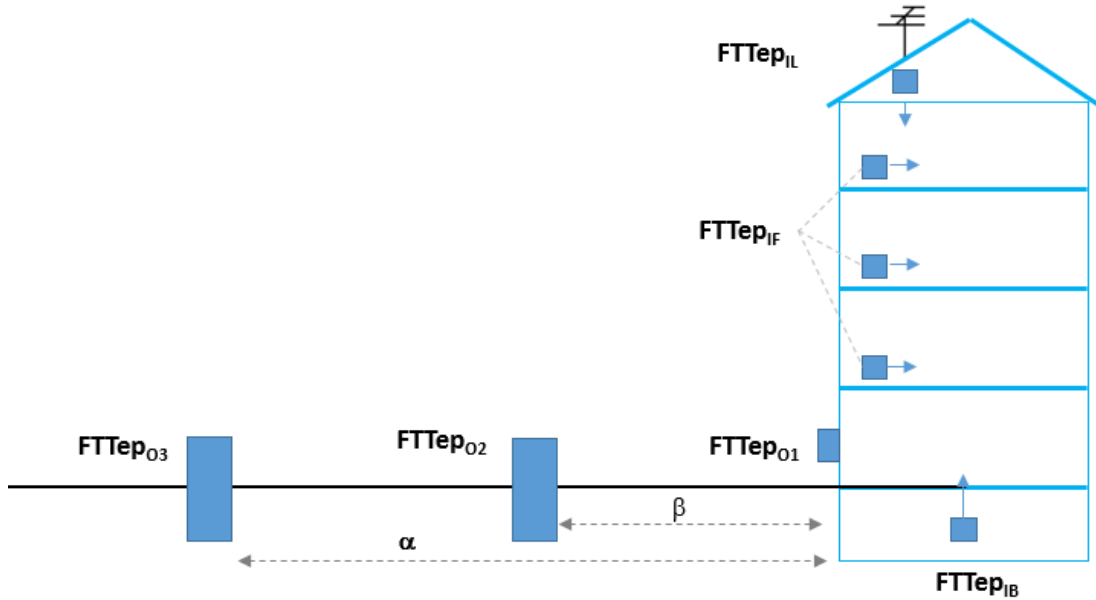

Figure 5-2: Typical Multi Dwelling Unit FTTEp deployment scenarios

Examples of extension point location in an FTTEp deployment scenarios are::

- **FTTEp_{O3} twisted pair outdoor cabinet or manhole** - EP is typically located at α distance from the SFU or MDU building located in a cabinet or manhole, where only twisted pair cables are available
- **FTTEp_{O2} twisted pair or coaxial outdoor cabinet or manhole** - EP is typically located at β distance from the SFU or MDU building located in a cabinet or manhole, where twisted pair or coaxial cables are available
- **FTTEp_{O1} twisted pair or coaxial outdoor wall cabinet** – EP is typically located on the outdoor wall of the SFU or MDU building located in a cabinet, where twisted pair or coaxial cables are available
- **FTTEp_{IB} twisted pair or coaxial basement** - EP is typically located in the basement of the SFU or MDU building, where twisted pair or coaxial cables are available
- **FTTEp_{IF} twisted pair or coaxial floor** – EP is typically located on floor level in the MDU building located in electrical raiser room, where twisted pair or coaxial cables are available
- **FTTEp_{IL} coaxial loft** - EP is typically located in loft of the MDU building, where only coaxial cables are available

6 FTTEP Use Cases and Deployment Scenarios

This section summarizes the main common features of the Use Cases (UCs) submitted by operators for extending fiber access over existing infrastructure with the objective to highlight points of convergence in the FTTEP deployments.

Classification of use cases follows the type (single or multi-tenant) and ownership (common or individual) of the infrastructure. With this approach, the following categories are defined:

- **Category 1:** multi-tenant, with shared copper network outside the living unit .
 - **Category 1a:** Share wire (shared cable, bundle)
 - Use Case 1a-1 – “Point-to-Point data-grade twisted pair for HSIA in MDU”
 - Use Case 1a-2 – “Point-to-Point telco-grade twisted pair for HSIA in MDU”
 - Use Case 1a-3 – “MDU Coaxial Cable services co-existing with the TV service”
 - Use Case 1a-4 – “MDU Coaxial Cable services co-existing with the Cable-TV and DOCSIS services”
 - Use Case 1a-5 – “MDU Coaxial Cable services using full coaxial spectrum”
 - Use Case 1a-6 – “Multiple Point-to-Multipoint (M-P2MP) over existing indoor phone wiring”
 - Use Case 1a-7 – “Extending fiber services using copper to the distribution point - Classic-No-RPF-Technician-Install”
 - Use Case 1a-8 – “Extending fiber services using copper to the distribution point - RPF with VoIP re-injection, Self-Install”
 - Use Case 1a-9 – “Extending fiber services using copper to the distribution point - RPF with VoIP, Single Port”
 - Use Case 1a-10 – “Extending fiber services using copper to the distribution point - P2MP-Self Install”
 - Use Case 1a-11 – “Fiber extension by concatenating copper distribution networks (CDNs)- CuTTB”
 - Use Case 1a-12 – Fiber extension by concatenating copper distribution networks (CDNs)- multiple E2Es
 - Use Case 1a-13 – “Fiber extension by concatenating copper distribution networks (CDNs) - dual use pairs”
 - Use Case 1a-14 – “Copper to Fiber Backhaul migration”
 - **Use case Category 1b:** Individual coaxial wiring
 - Use Case 1b-1 – “Point-to-Point Coaxial cabling with frequency diplexers for HSIA and satellite TV in MDU”
 - Use Case 1b-2 – “Point-to-Point Coaxial cabling for HSIA in MDU”
- **Category 2:** Exclusively-used wiring (i.e, single-tenant) outside the living unit. (e.g., single-family unit)
 - Use Case 2-1 – “Single port Point-to-Point data-grade twisted pair or coaxial cabling”
 - Use Case 2-2 – “Multiple port Point-to-Point data-grade twisted pair or coaxial cabling”

6.1 Use Cases Category 1a: Multi-tenant, with shared copper network outside the living unit

6.1.1 Use Case 1a-1 – “Point-to-Point data-grade twisted pair for HSIA in MDU”

Table 6-1: Use Case 1a-1

Use Case	Name
1a-1	Use Case 1a-1 – “Point-to-Point data-grade twisted pair for HSIA in MDU”

This Use Case is called “Point-to-Point data-grade twisted pair for HSIA in MDU”. It addresses the situation where data-grade twisted pairs provide HSIA service in an MDU.

The O2E serving multiple living units in an MDU, typically in the range of one to a few tens, located in an equipment room or a cabinet near the MDU.

G-PON or XG-PON/XGS-PON fiber connects the O2E to the network. Each O2E includes an ONU and one or more NHEs.

Figure 6-1 illustrates the case with the NHE modem serving one customer and connecting one NTE/RGW to the line over telephony wires. Service installation may require a technician visit to the living unit. Within living unit up to 200 meters of Category 5/5e and Category 6 twisted wiring are typically used. Wi-Fi, Ethernet or other LAN in the premises connects multiple EUDs to the RGW.

This Use Case is illustrated in Figure 6-1 using the terminology from Section 4.

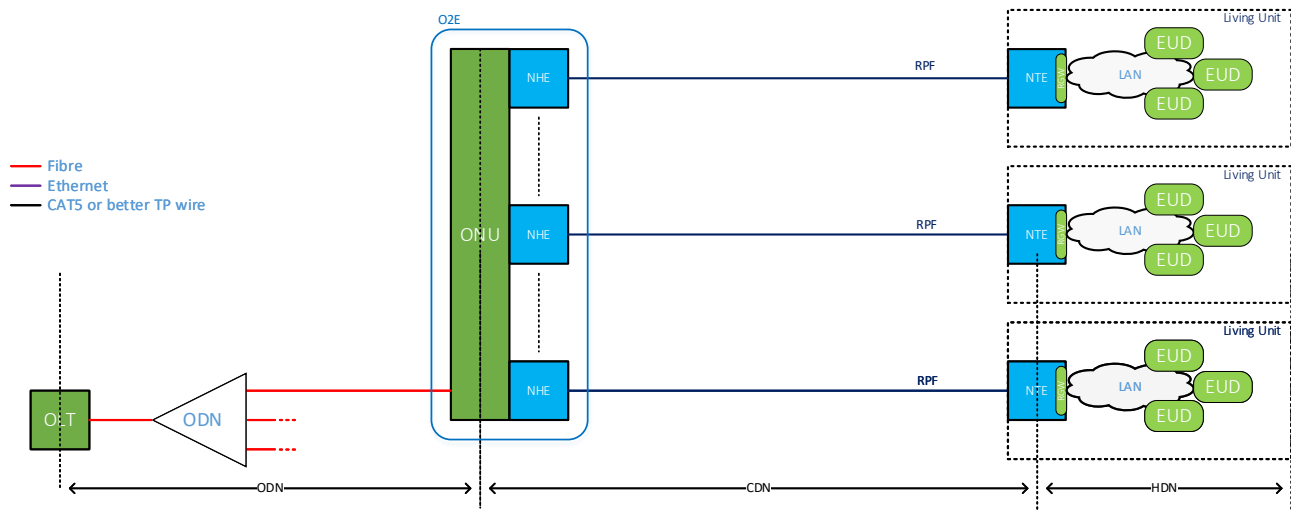

Figure 6-1: P2P data-grade twisted pair for HSIA in MDU - Generalized Use Case 1a-1

6.1.2 Use Case 1a-2 – “Point-to-Point telco-grade twisted pair for HSIA in MDU”

Table 6-2: Use Case 1a-2

Use Case	Name
1a-2	Use Case 1a-2 – “Point-to-Point telco-grade twisted pair for HSIA in MDU”

This Use Case is called “Point-to-Point telco-grade twisted pair for HSIA in MDU”. It addresses the situation where telephone wires in an MDU are used to provide HSIA to the living units. Due to the use of telephone wires, crosstalk between pairs may exist in the system.

The O2E serves multiple living units in an MDU, typically in the range of a higher number of tens, with the O2E located in an equipment room or a cabinet near the MDU. G-PON or XG-PON/XGS-PON fiber connects the O2E to the network. Each O2E includes an ONU and one or more NHEs. Each customer/living unit, having one NTE/RGW, is connected to the line and O2E modem over telephony wires. Service installation may require a technician visit to the living unit. Within the living unit up to 100 meters of telephony wires are used. Wi-Fi, Ethernet or other LAN in the premises connects multiple EUDs to the RGW.

This Use Case is illustrated in Figure 6-2 using the terminology from Section 4.

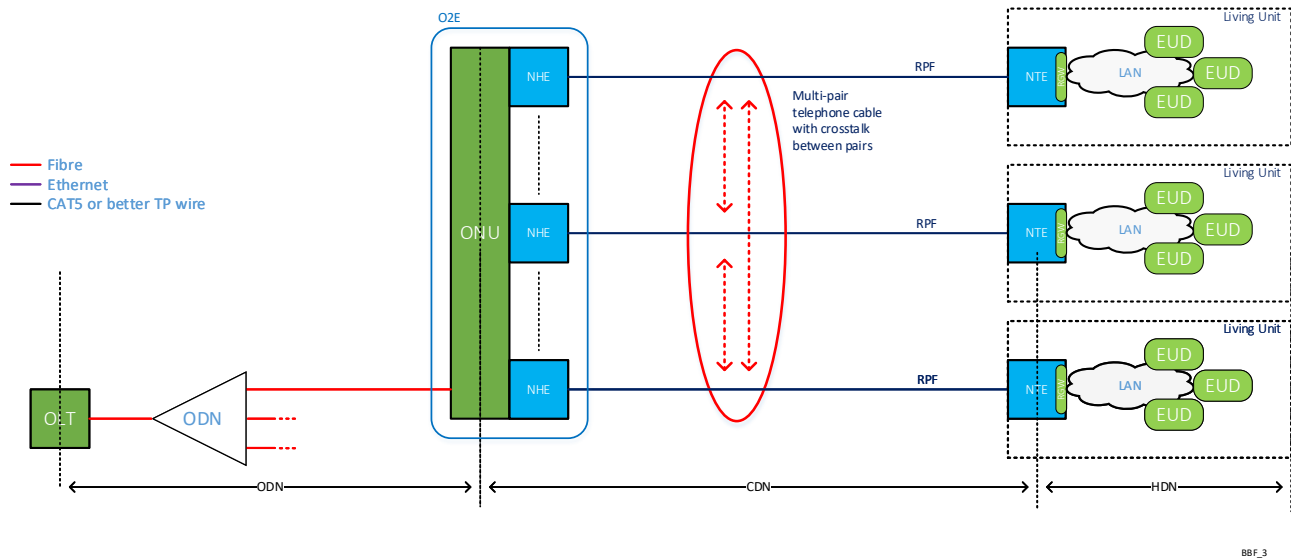

Figure 6-2: P2P telco-grade twisted pair for HSIA in MDU - Generalized Use Case 1a-2

6.1.3 Use Cases 1a-3/4/5 – “MDU Coaxial Cable Services” Use Cases

Table 6-3: Use Cases 1a-3/4/5

Use Case	Name
1a-3	Use Case 1a-3 – “MDU Coaxial Cable services co-existing with the TV service”
1a-4	Use Case 1a-4 – “MDU Coaxial Cable services co-existing with the Cable-TV and DOCSIS services”
1a-5	Use Case 1a-5 – “MDU Coaxial Cable services using full coaxial spectrum”

This set of Use Cases is called the MDU Coaxial Cable Services.

It addresses the situation where it is not possible to deploy FTTH within an MDU building. Typical barriers that delay and increase cost of FTTH deployment may be building owners that are not ready to pay for the in-building fiber deployment cost, and condominium apartment owners that don’t see any reason for construction work within the apartments.

The MDU coaxial cabling use case eliminates the in-building construction work and increases the deployment speed within an MDU building by using the existing in-building coaxial network as a PON fiber extension to each apartment.

The general description of this group of use cases is illustrated in Figure 6-3 and their details in the following sections.

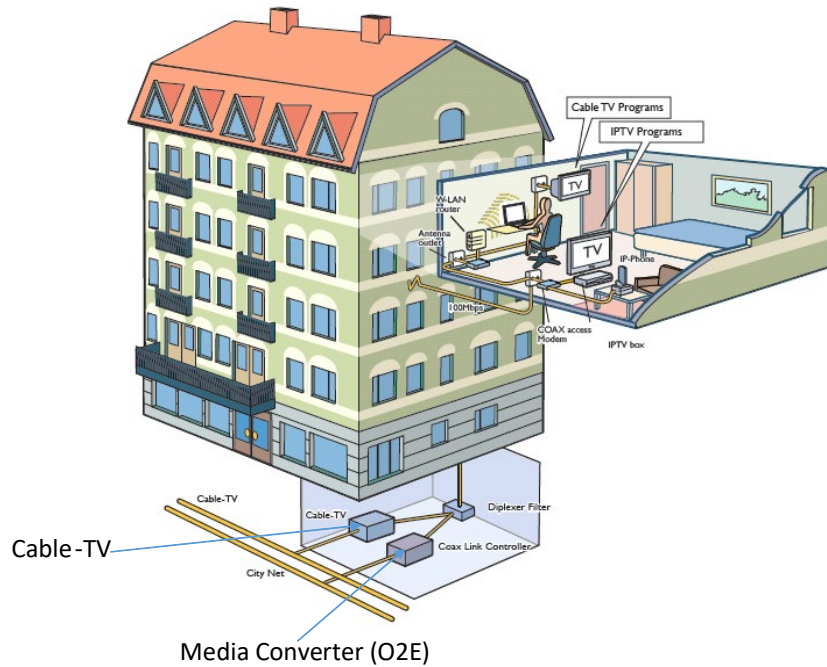

Figure 6-3: Coaxial Cabling can co-exist with existing TV, Cable-TV or Satellite services by using different frequency bands in the coaxial network

Basically, all MDU buildings have a coaxial network which reaches all apartments, with at least one TV outlet per household, typically in the living room.

A PON service provider needs a Fiber into the building to the TV amplifier location. The Fiber is terminated in the O2E. This O2E is connected to the passive coaxial network through a diplexer filter which combines existing TV, cable-TV or Satellite services depending which frequency band is available for the PON operator services.

All apartments have a TV outlet, to which TV set or set-top box and an eventual cable modem are connected. When a PON provider starts to offer new competing services, subscribers replace eventual cable modem with a new modem or gateway which is provided by the PON service provider.

A PON operator signs an agreement to have the rights to use unused spectrum in the in-building coaxial network and to use the building’s power supply to the O2E. The PON service provider can offer the building owner competing services to its tenants and an alternative future TV service offering which is in line with building owners desire to have alternative services to its tenants.

6.1.3.1 Use Case 1a-3 – “MDU Coaxial Cable services co-existing with the TV service”

A coaxial network can have a spectrum of 5-2400 MHz of which TV is using 5-790 MHz alternatively 5-690 MHz depending of what is reserved for mobile networks. So, spectrum above TV spectrum is available for broadband services.

An O2E is installed in the basement or loft converting the PON (for example G-PON) signal to high frequency modulated signal by the RF-Transceiver in the O2E. The coaxial network can have different type of topology to which each MDU apartment Residential Gateway (RGW) is connected by the RGW in-built Transceiver (TR). Transceiver have a passive diplexer filter which divide the signal to TV set or set-top box and the data signal to the RGW. The RF-transceiver have same link speed throughput performance as the incoming G-PON signal. The ONU is a SFP module which converts the optical signal to electrical and the RF-Transceiver and TR is a transparent bridge for the delivered services. It can support CPE management tools as TR-069. DPX is a diplexer filter / combiner which isolate TV band and the RF-Transceiver band and combines the different RF-bands. Tap is a coaxial tap which divide the RF signal to each apartment, see more under Appendix A. The O2E have also management capabilities to manage the coaxial link and L2 support.

This Use Case is illustrated in Figure 6-4 using the terminology from Section 4.

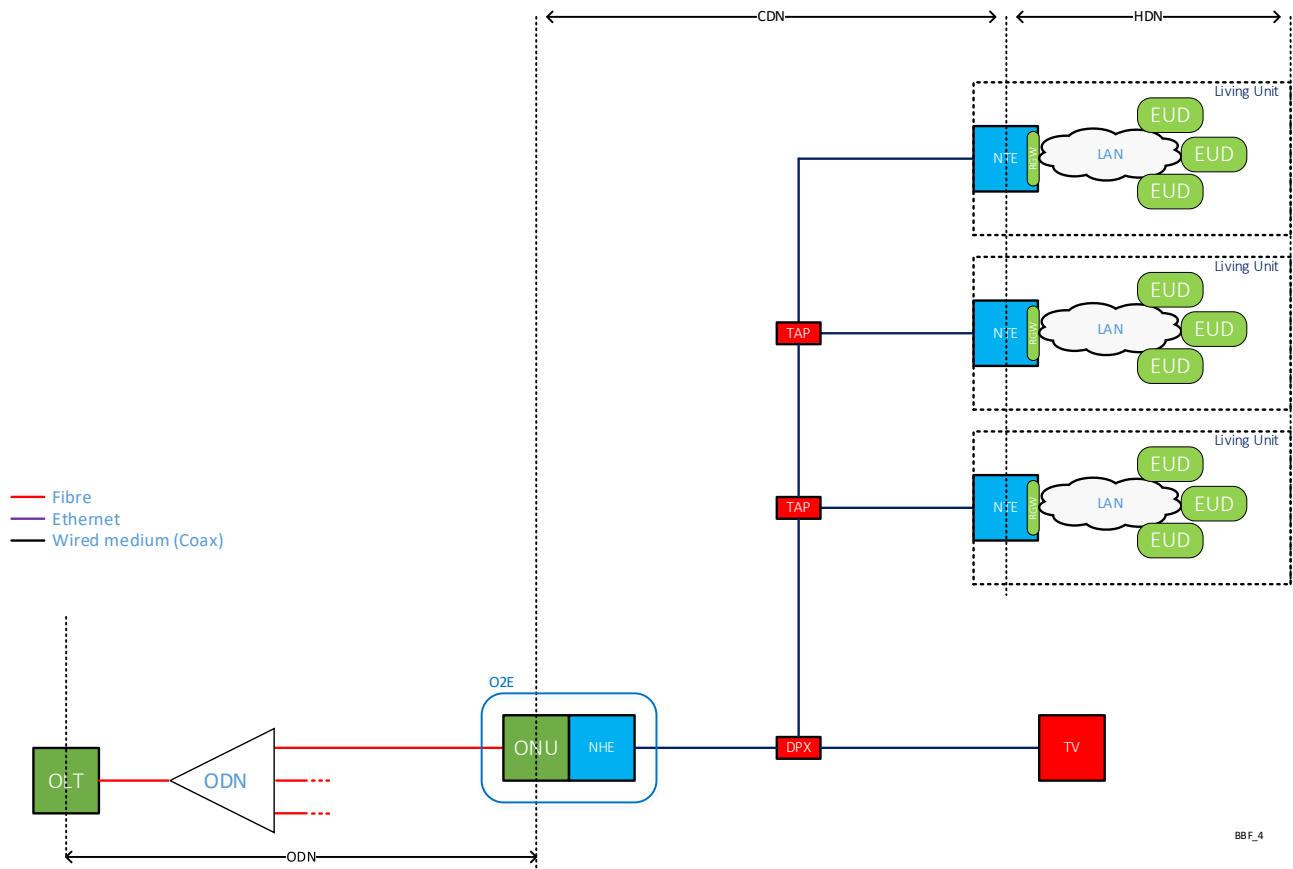

Figure 6-4: MDU Coaxial Cable services coexisting with the TV service - Generalized Use Case 1a-3

6.1.3.2 Use Case 1a-4 – “MDU Coaxial Cable services co-existing with the Cable-TV and DOCSIS services”

A coaxial network can have a spectrum of 5-2400 MHz of which Cable TV and DOCSIS is using 5-860 MHz alternatively 5-1002 MHz deepening of DOCSIS 3.0 version and with DOCSIS 3.1 it uses 5-1218MHz. So, spectrum above Cable-TV spectrum is available for other broadband services.

In the basement is an O2E installed which converts the PON (for example G-PON) signal to high frequency modulated signal by the RF-Transceiver in the O2E. The coaxial network can have different type of topology

to which each MDU apartment Residential Gateway (RGW) is connected by the RGW in-built Transceiver (TR). Transceiver have a passive diplexer filter which filter the signal to TV set, set-top box or DOCSIS modem and the data signal to the RGW. The RF-transceiver have same link speed throughput performance as the incoming G-PON signal. The ONU is a SFP module which converts the optical signal to electrical and the RF-Transceiver and TR is a transparent bridge for the delivered services. It can support CPE management tools as TR-069/TR-369. DPX is a diplexer filter / combiner which isolate TV band and the RF-Transceiver band and combines the different RF-bands. Tap is a coaxial tap which divide the RF signal to each apartment, see more under Appendix A. The O2E have also management capabilities to manage the coaxial link and L2 support.

This Use Case is illustrated in Figure 6-5 using the terminology from Section 4.

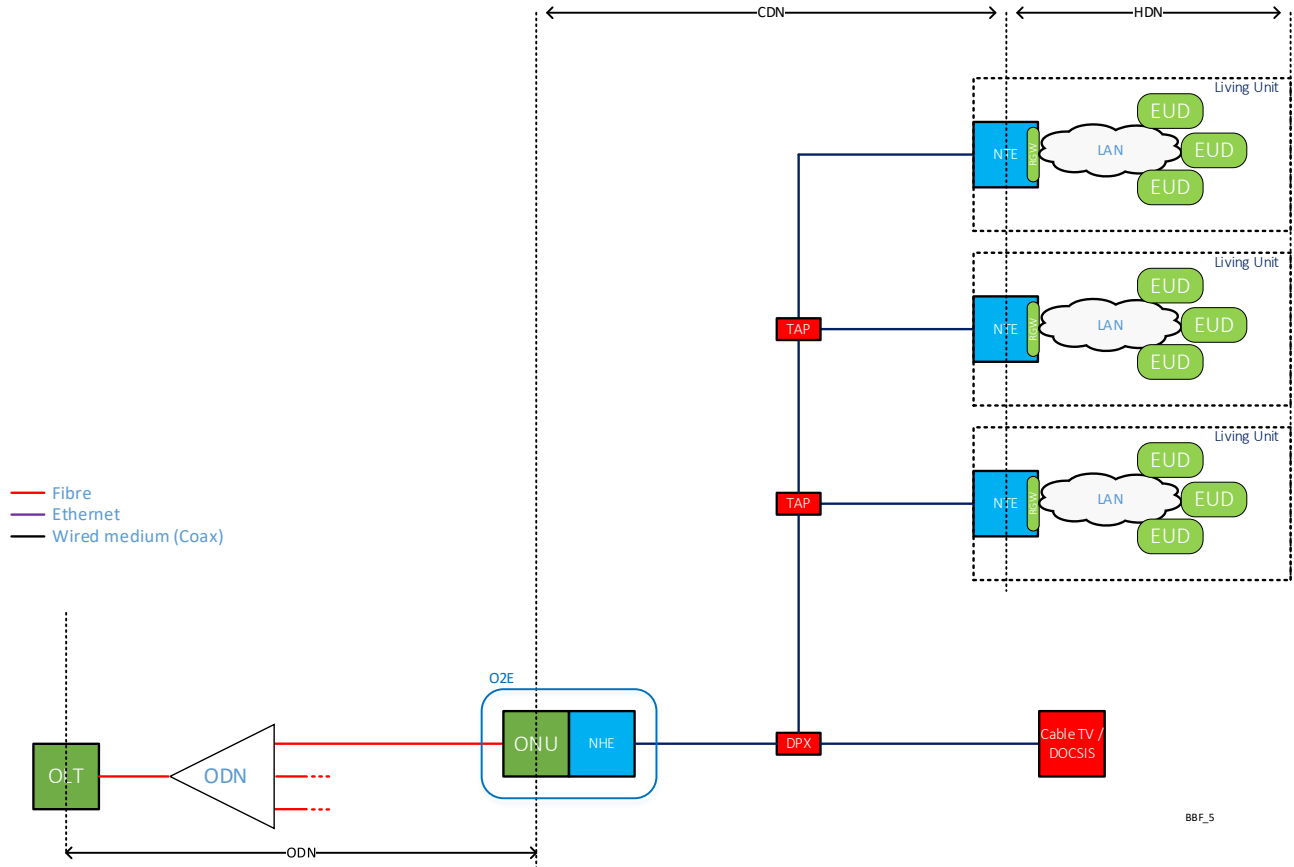

Figure 6-5: MDU Coaxial Cable co-existing with the Cable-TV and DOCSIS services - Generalized Use Case 1a-4

6.1.3.3 Use Case 1a-5 – “MDU Coaxial Cable services using full coaxial spectrum”

A full coaxial spectrum network has a spectrum of 5-2400 MHz without any other services. Typically, broadband services are using dual RF-bands between 400-1675MHz providing two RF-bands with 2,5Gbps capacity each. Next generation PON systems (NG-PON) capable of supporting transmission rates of at least 10 Gbit/s in the downstream direction will be used in junction with a coaxial network operating in full spectrum up to 1800MHz.

In the basement or loft is an O2E installed which converts the PON (for example G-PON or in future NG-PON) signal to high frequency modulated signal by the RF-Transceiver in the O2E. The coaxial network can have different topology to which each MDU apartment Residential Gateway (RGW) is connected by the RGW in-built Transceiver (TR). The RF-transceiver have same link speed throughput performance as the

incoming GPON or NG-PON signal. The ONU is a SFP module which converts the optical signal to electrical and the RF-Transceiver and TR is a transparent bridge for the delivered services. It can support CPE management tools as TR-069. The O2E have also management capabilities to manage the coaxial link and L2 support.

This Use Case is illustrated in Figure 6-6 using the terminology from Section 4.

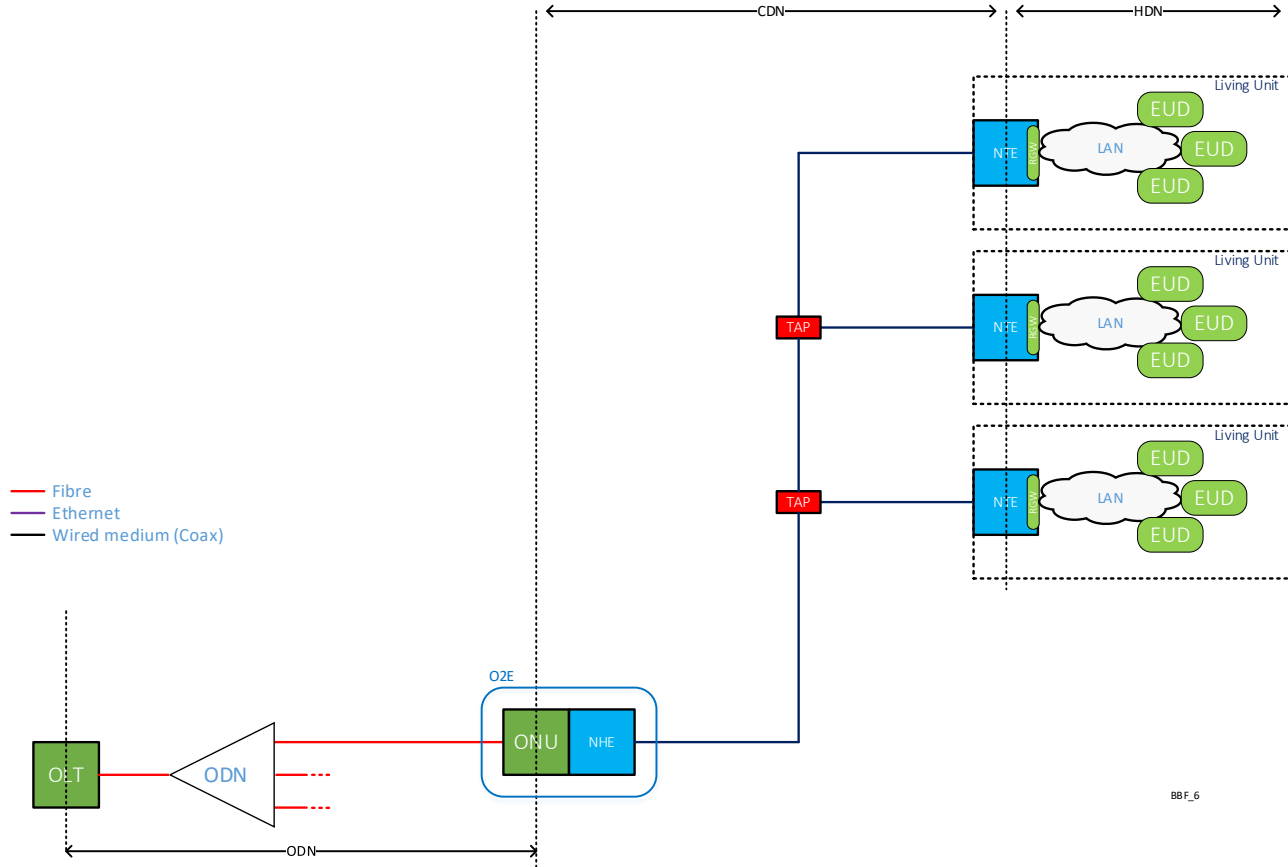

Figure 6-6: MDU Coaxial Cable services using full coaxial spectrum - Generalized Use Case 1a-5

6.1.4 Use Case 1a-6 – “Multiple Point-to-Multipoint (M-P2MP) over existing indoor phone wiring”

Table 6-4: Use Case 1a-6

Use Case	Name
1a-6	Use Case 1a-6 – “Multiple Point-to-Multipoint (M-P2MP) over existing indoor phone wiring”

This use case addresses the situation where one modem/transceiver is serving multiple subscriber lines (M-P2MP) with the same PHY layer. These subscribers are sharing the capacity of this PHY layer dynamically according to the present traffic demand of the subscribers.

Increasing channel data rates (>1Gbps) and peak to average traffic ratio. (similar as for PON or DOCSIS), allows to use shared media transmission systems without degrading customer experience, by exploiting statistical multiplexing effects. In addition, the PHY layer capacity must be shared among active customer lines only. Thus, active customer lines are benefitting directly from the numerous non-active subscriber lines. Consequently, M-P2MP deployment allows to reduce the hardware and network cost per customer.

This Use Case is illustrated in Figure 6-7 using the terminology from Section 4.

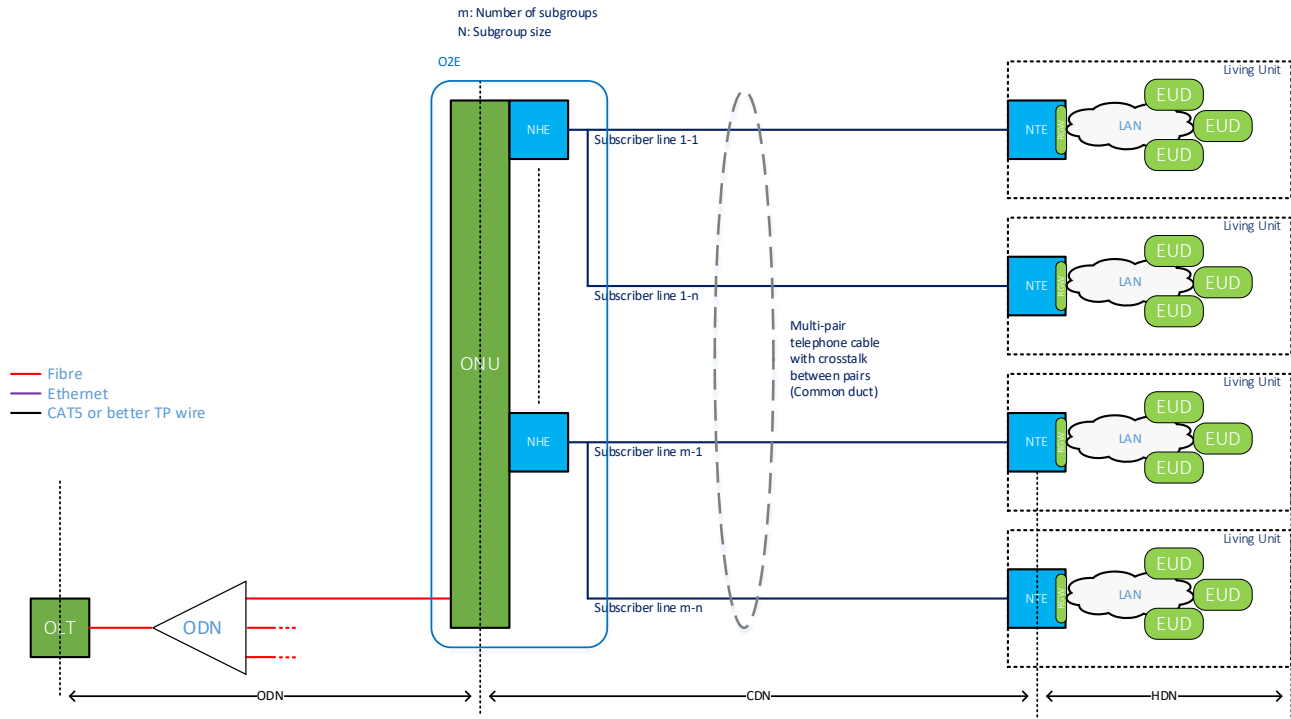

Figure 6-7: M-P2MP over existing indoor phone wiring - Generalized Use Case 1a-6

In this use case the O2E node may contain multiple modems/transceivers. Each modem/transceiver is connected to multiple ports of the O2E node, thereby providing the same access PHY layer over multiple subscriber lines. On the subscriber side the access PHY layer is terminated by home gateways. There is a 1-to-1 mapping between the ports of the O2E node and the subscriber lines. There is also a 1-to-1 mapping between subscriber lines and home gateways. However, since the same PHY layer is used by multiple home gateways, we are nonetheless dealing with a P2MP topology between the modem and the home gateway. The set of subscriber lines/O2E node ports connected to the same modem/transceiver is called a P2MP subgroup. All lines within one P2MP subgroup will share the same PHY layer. Lines in different P2MP subgroups will have independent PHY layers.

In the downstream the same signal is sent to all home gateways belonging to the same P2MP subgroup. The multiple subscriber lines of a P2MP subgroup are used as a shared media, where each home gateway is listening exclusively to its dedicated downstream data (logical data channel on MAC Layer).

In the upstream each home gateway has a dedicated logical data channel where it is sending traffic.

Resources are allocated dynamically per subscriber according traffic demand for both, up and downstream.

In this use case, all subscriber lines are passing through a common duct/tube in the vertical riser, which may have a length of several tens of meters. Consequently, FEXT will appear between all subscriber lines. Within one P2MP subgroup all lines are fed with the same signal in the downstream. Consequently, downstream vectoring within one P2MP subgroup will not be possible. However, it is assumed not to be necessary either. Since the signals on different lines of a P2MP subgroup have the same source, we are rather facing a multipath propagation than a crosstalk situation. By using equalization, the receiver is expected to demodulate the source signal correctly.

However, subscriber lines belonging to different P2MP subgroups/PHY layer are experiencing a crosstalk situation, since they are associated with different and independent signal sources. Between such subscriber lines self-FEXT cancellation is required.

6.1.5 Use Cases 1a-7/8/9/10 – “Extending fiber services using copper to the distribution point – use cases”

Table 6-5 lists a collection of FTTdp use cases relating the extension of fiber services using copper to the distribution point

Table 6-5: Use Cases 1a-7/8/9/10/11

Use Case	Name
1a-7	Use Case 1a-7 – “Extending fiber services using copper to the distribution point -Classic-No-RPF-Technician-Install”
1a-8	Use Case 1a-8 – “Extending fiber services using copper to the distribution point - RPF with VoIP re-injection, Self-Install”
1a-9	Use Case 1a-9 – “Extending fiber services using copper to the distribution point - RPF with VoIP, Single Port”
1a-10	Use Case 1a-10 – “Extending fiber services using copper to the distribution point - P2MP-Self Install”

Generic issues of wiring ownership influence most use cases, particularly in the distinction between home and MDU deployments.

The limit of the carrier’s responsibility is up to the Network Termination Point (NTP) where exists an assembly of, formally defined network-side elements (including protection) that are not easily accessible by the end customer, and customer side that facilitates connection to a private in-home network of telephone extension wiring. A simple in-home use case of NTP and CPE connection is shown in Figure 6-8. The terms NTE and CPE are used interchangeably in these use cases.

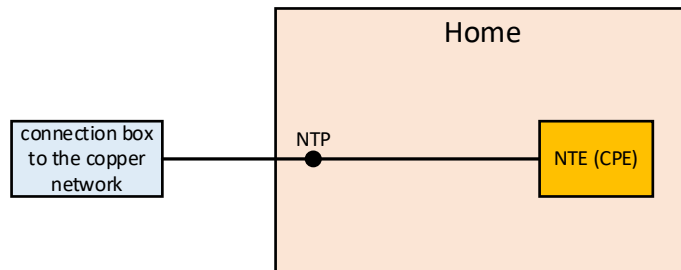

BBF_20

Figure 6-8: Home, NTP and NTE connection

In the case of an MDU there may be two NTPs. The formal limit of the carrier’s responsibility may be at an entry point to the building on a connector block in shared space, while there may also be an NTP inside the end-user’s apartment. In some buildings the ownership of the inside wiring is clearly with the building owner, but in other cases particularly in the case of public housing, the inside wiring may have been adopted by an operator. Both situations may be encountered in MDUs.

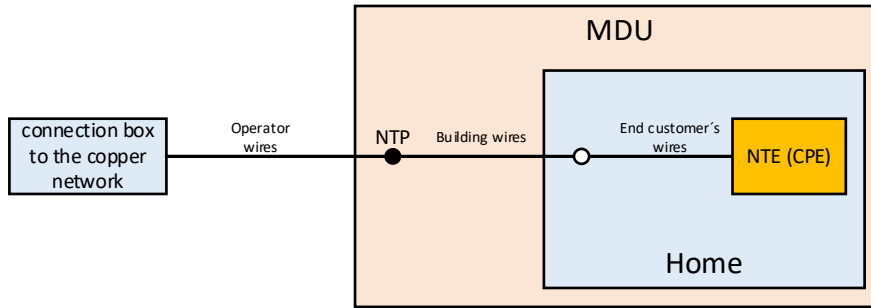

BBF_21

Figure 6-9: MDU with in-building wiring

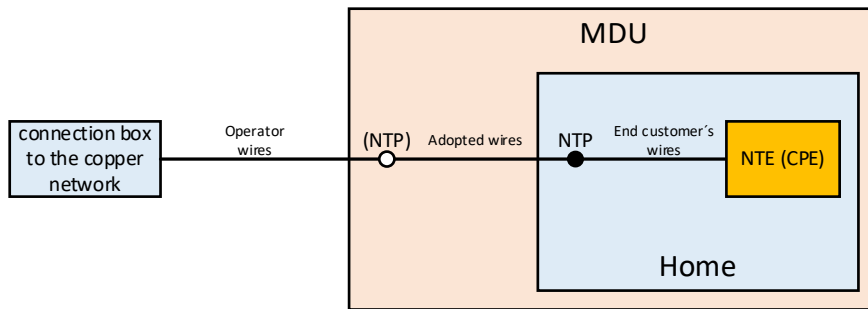

BBF_22

Figure 6-10: MDU with operator adopted in-building wiring

The Fiber Extension use-cases described in the next sections may instead employ copper backhaul but be otherwise identical. Refer to Use Case 1a-14 – “Copper to Fiber Backhaul migration”.

6.1.5.1 Use Case 1a-7 – “Extending fiber services using copper to the distribution point -Classic-No-RPF-Technician-Install”

This is the classical FTTdp use-case where either an engineer or end customer installed home gateway terminates the access section inside the home and provides routing functionality and multiple in-home networking options. For technician install a service splitter is installed at the NTP to isolate data and analogue telephone wiring. For self-install low pass (LP) filters are required at extension telephony equipment. For some operators this is essentially the first-generation deployment scenario. In future, higher speed deployments this scenario is most likely to be encountered in MDU situations where RPF is not needed.

In practice after self-install, proper service installation may require a technician to visit the living unit for premium service, to mitigate service instability due to severe extrinsic noise, flawed internal wiring, or to recover from an unexplained installation failure.

This Use Case, including the technician and self-install variants, is illustrated in Figure 6-11 using the terminology from Section 4.

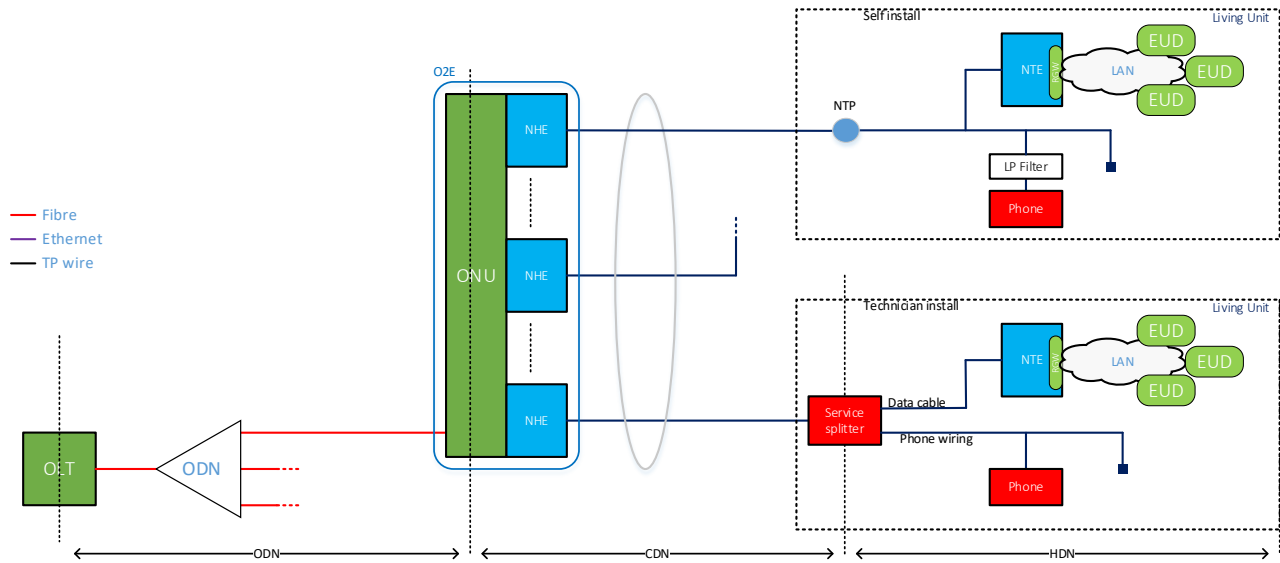

BBF_8

Figure 6-11: Extending fiber services using copper to the distribution point -Classic-No-RPF- Technician-Install - Generalized Use Case 1a-7

The O2E serves dwellings units in a variety of topologically equivalent contexts: from individual detached houses in clusters, to high density terraced houses in an urban setting; MDUs from large houses subdivided into a few small units, up to multi-story purpose-built blocks of flats. The O2E may be located in a footway box, at the top of a pole, screwed to an outside wall, or in a shared space in an MDU.

Wi-Fi, Ethernet, or other in-premises network technologies connect multiple end-user terminal devices.

6.1.5.2 Use Case 1a-8 – “Extending fiber services using copper to the distribution point - RPF with VoIP re-injection, Self-Install”

This is the FTTdp use-case where the end user or their agent installs the home gateway which terminates the access section inside the home, and provides routing functionality, provides reverse power feeding, and derived VoIP telephony, and supports multiple in-home networking options.

There is no exchange based POTS but an equivalent VoIP service terminates in an ATA in the Home Gateway and then re-injects onto the in-home wiring to reach phone extensions. The telephony coexists with RPF by use of out-of-band telephony signaling. Conventional telephony instruments can be connected at the phone extension sockets via active ‘dongle’.

A technician install variant of this use case exists with analogue voice re-injection at the NTP service splitter. This avoids the need for active ‘dongle’.

This Use Case is illustrated in Figure 6-12 using the terminology from Section 4.

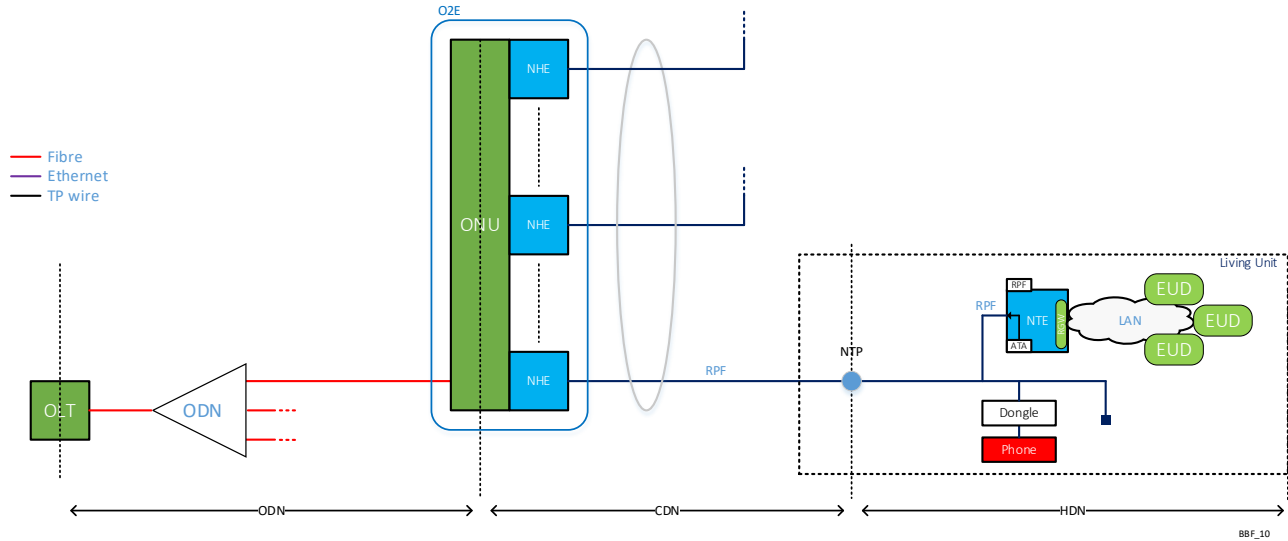

Figure 6-12: Extending fiber services using copper to the distribution point - RPF with VoIP re-injection, Self-Install - Generalized Use Case 1a-8

6.1.5.3 Use Case 1a-9 – “Extending fiber services using copper to the distribution point - RPF with VoIP, Single Port”

This use-case is the same as the one in section 6.1.5.2, except that only one physical telephony port is provided, which is not connected to the internal phone wiring, and in-home phone networking is accomplished by DECT.

This Use Case is illustrated in Figure 6-13 using the terminology from Section 4.

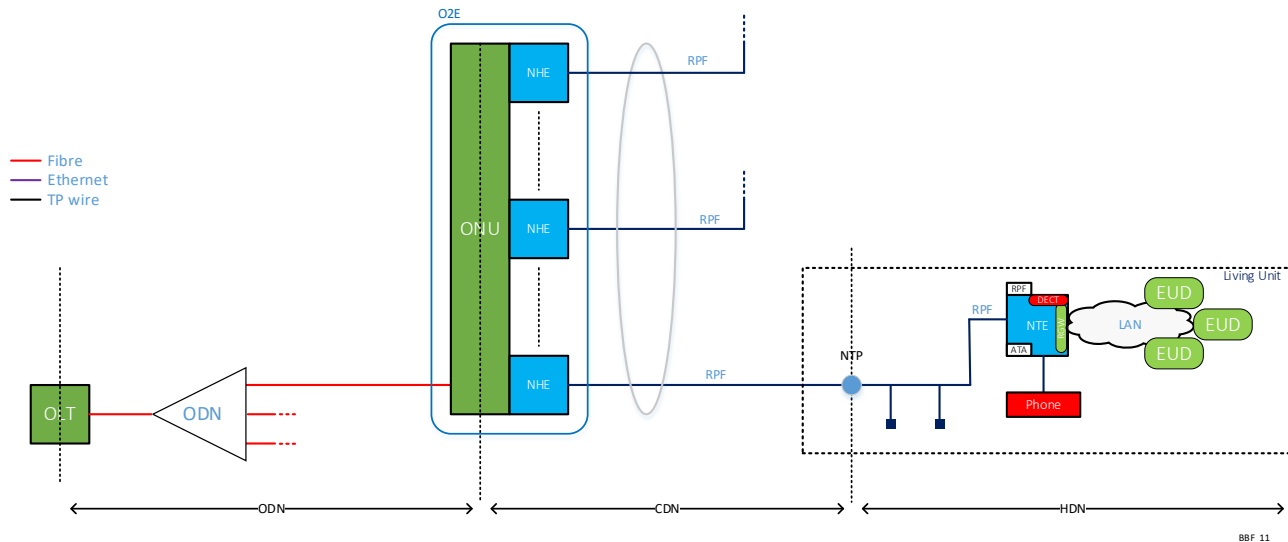

Figure 6-13: Extending fiber services using copper to the distribution point - Classic-with-RPF Self-Install and derived POTS - Generalized Use Case 1a-9

6.1.5.4 Use Case 1a-10 – “Extending fiber services using copper to the distribution point - P2MP-Self Install”

In this use-case the access section is terminated in multiple terminals inside the home. The phone wiring extensions may be terminated in Wi-Fi access points, set-top boxes or a home gateway which may also provide a wireless access point. The home gateway provides routing to other home networking facilities such as Category 5 twisted pair cable and power lines, and Wi-Fi M-P2MP.

This Use Case is illustrated in Figure 6-14 using the terminology from Section 4.

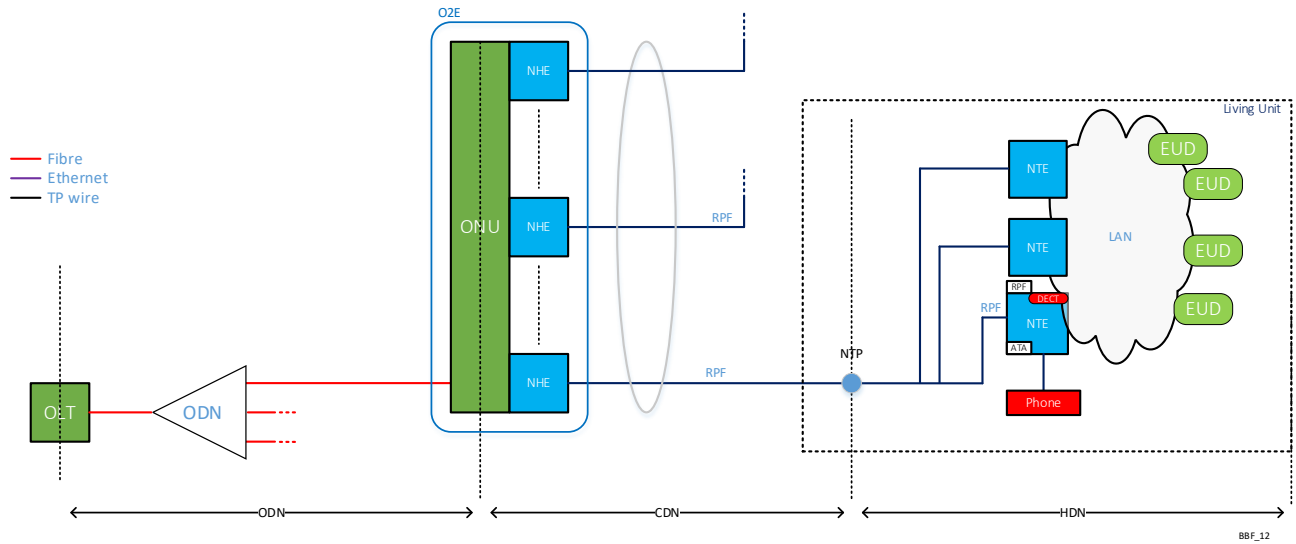

Figure 6-14: Extending fiber services using copper to the distribution point - P2MP, Self-Install - Generalized Use Case 1a-10

The O2E provides Ethernet MUX/DEMUX functionality allowing connection between terminals over the in-home phone wiring. Telephony is supported by one or both of an analogue phone port on the main gateway termination or DECT cordless phone networking.

6.1.6 Use Case 1a-11 – “Fiber extension by concatenating copper distribution networks (CDNs)- CuTTB”

Table 6-6: Use Case 1a-11

Use Case	Name
1a-11	Use Case 1a-11 – “Fiber extension by concatenating copper distribution networks (CDNs)- CuTTB”

This use case is called CuTTB. It addresses the situation where a copper distribution node is installed in an MDU, similar as for FTTB, but where the copper distribution node is backhauled by bonded access lines. Competition may drive Telcos soon to provide data rates up to 1Gbps. Line bonding to reach such data rates is often not feasible because there are too few existing copper lines ending at the customer premises. Laying additional copper cables is not an option either, because cost would already be comparable with FTTH. An option to reach the target data rate for MDUs is to build FTTB and to apply either larger spectrum profiles from the O2E to the CPE over existing in-building copper infrastructure. This would avoid the replacement of the in-building vertical by fiber. However, for FTTB the fiber drop must still be built. The rollout of the fiber drop is costly and slow and may not allow to react sufficiently fast to market needs.

Instead of rolling out the fiber drop, we could use the existing copper drop for backhauling a new (In-)Building Copper Node (BCN). The BCN would be installed in a similar location inside the building as the FTTB node. Whereas FTTB uses fiber for the uplink, Copper To The Building (CuTTB) uses copper bonding in the existing drop and aggregates the capacity of multiple copper pairs for the uplink. This use case is illustrated in Figure 6-15.

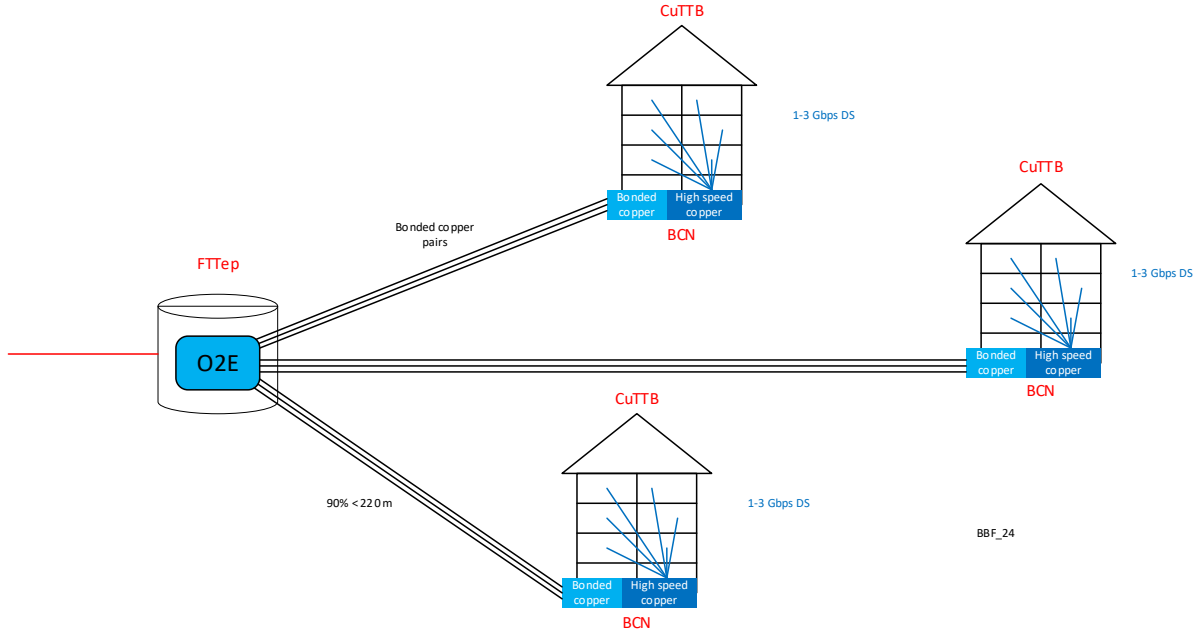

Figure 6-15: Fiber extension by concatenating copper distribution networks (CDNs)- CuTTB – Generalized Use case 1a-11

In MDUs we have typical in-building loop lengths of 30 to 70m. Using larger spectrum profiles, the BCN could reach typically 1-3 Gbps downstream IP rate per subscriber. Using the existing O2E as higher order network node and assuming >400 Mbps downstream IP rate for 90% of the lines, with bonding a copper backhaul of typically 3 Gbps per 8 pairs could be provided for the BCN. As the node would be used for MDUs with 5 to 16 dwellings, an 8 and/or 16 port device would be needed. In this use case the O2E node is a DPU with 16 or 48 ports, residing in a manhole and has bonding capabilities. To comply with legacy CPEs and very long lines, the O2E should support multimode per port (G.fast/VDSL). To be used on multipair access cables the O2E must support self-FEXT mitigation (vectoring). Since the indoor phone wiring of MDUs tends to strong crosstalk in the vertical riser, the subscriber ports of the BCN must support self-FEXT mitigation. To comply with legacy CPEs the BCN should support as well multimode per port (G.fast). Since subscriber and uplink copper wires of the BCN may have crosstalk, downlink/uplink NEXT avoidance/cancellation may be necessary.

6.1.7 Use Case 1a-12 – Fiber extension by concatenating copper distribution networks (CDNs)- multiple E2Es

Table 6-7: Use Case 1a-12

Use Case	Name
1a-12	Use Case 1a-12 – Fiber extension by concatenating copper distribution networks (CDNs)- multiple E2Es

This use case addresses situations where spare pairs are available in an existing telephone cable from a fiber-fed cabinet to the different O2Es. Thus, the O-to-E function is located at the neighborhood cabinet. Various copper transmission technologies could be used. A single link can reach approximately 300m. To reach further, this use case provides for up to three tandem links, with a total reach from the fiber-fed cabinet to the customer of more than one kilometer, including the final drop line, enabling an aggregate service rate on the order of 500 Mb/s to serve Single Family Homes (SFUs) or Multi-Dwelling Units (MDUs). This Use Case is illustrated in Figure 6-16.

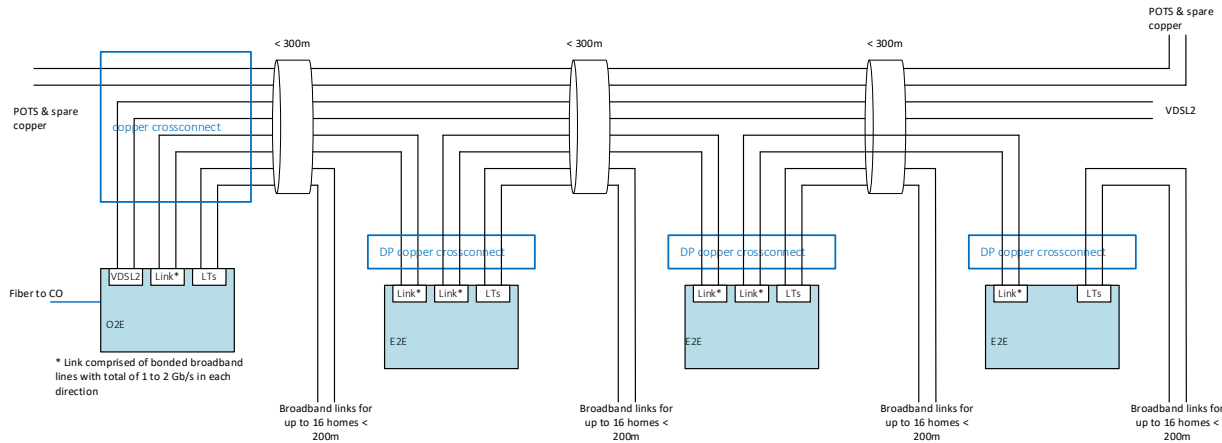

Figure 6-16: O2E backhaul using up to three sections of bonded copper lines - Use Case 1a-12

The fiber-fed cabinet at the left side of the figure above serves VDSL2 access lines, access lines (broadband links) to customers up to 200m long (LTs), and bonded backhauling lines serving as the link to the subtended E2Es. The bonded backhaul should provide a total backhaul capacity of 1 -2 Gb/s which is shared by several E2Es connected in tandem. Each E2E, except the last one, act as a repeater for the backhaul links. The entire downstream and upstream backhaul should be available at all E2Es so that if there is heavy traffic at any one E2E, it can use most of the backhaul capacity for a short time. The drop lines to the individual customers could use a variety of copper technology (broadband links). The drop lines may be served from the cabinet as well as each E2E. The drop line could provide reverse power feeding (RPF) to the E2E, or alternatively, wire pairs from the cabinet to the E2Es could provide “forward power” from a power source at the cabinet. Crosstalk may exist between the uplink, downlink, and drop lines at each E2E, which can be partially addressed by synchronizing the TDM transmissions for the transceivers at all the E2Es and the cabinet. However, additional methods, including dynamic spectrum management (DSM) may be needed to address the remaining crosstalk.

6.1.8 Use Case 1a-13 – “Fiber extension by concatenating copper distribution networks (CDNs) - dual use pairs”

Table 6-8: Use Case 1a-13

Use Case	Name
1a-13	Use Case 1a-13 – “Fiber extension by concatenating copper distribution networks (CDNs) - dual use pairs”

This use case addresses the need to offer fiber like broadband service to customers who reside beyond the reach and capability of current deployed copper access. The use case employs bonded copper pairs to backhaul distribution point units (DPUs) downstream of a cabinet unit. The bonding enables new high capacity nodes closer to the customer with backhaul comparable to that of fiber. Multiple E2Es may be

subtended from a single cabinet and the cabinet can also serve end customers directly. The use case allows coexistence with legacy DSL through the use of dual use pairs.

The cabinet is the O2E as per the FTTEp terminology and architecture in clause 4. The subtended E2Es as per FTTEp terminology and architecture in clause 4. The bonded copper pairs abbreviated BG (bonding group).

Some operators' deployed access technologies are at the cabinet as this is cheaper and quicker than deploying at the distribution point. However, a significant percentage of users on a given cabinet may still be out of reach. Deploying fiber deeper into the network is costly and slow particularly for scenarios without duct, where cables are buried direct in ground.

To be comparable to full fiber solutions, the copper-based backhauled solution should be capable of providing a 500Mb/s or 1Gb/s service downstream. New access technologies must often coexist with legacy technologies. Migration can be slow and on day of deployment the majority of lines will be on legacy services.

The backhaul solution requires multiple bonded lines between the cabinet and E2E. Spare pairs may be used for this purpose though availability can be limited and non-uniformly distributed across the network. Unoccupied spectrum, on active pairs already providing legacy services, may also be used for backhaul through use of splitters at the cabinet and E2E. Spectrum above the legacy services may be used to backhaul E2E without impacting legacy services on the same pair.

The E2E would be installed between O2E and end user premises, predominantly in footway boxes and on telegraph poles and would therefore need to be a sealed unit. A smaller proportion of units may be indoor/basement deployment.

Customers served directly from the O2E and pairs used as backhaul links to E2E are part of the same bundle and may experience crosstalk that needs to be cancelled. The use case includes dual-use of backhaul pairs, where legacy cabinet or exchange hosted services operate over the same circuit as backhaul connections with frequency separation as far as the E2E.

Figure 6-18 shows the high-level architecture for this use case. Note the legacy access may be located at either the exchange or cabinet.

Note: Legacy DSL (Figure 6-17 – Tech 1) may be also be located at exchange. When mentioned in description the cabinet unit refers primarily to a new fiber extension technology (Figure 6-17 – Tech 2), i.e., non- legacy technology.

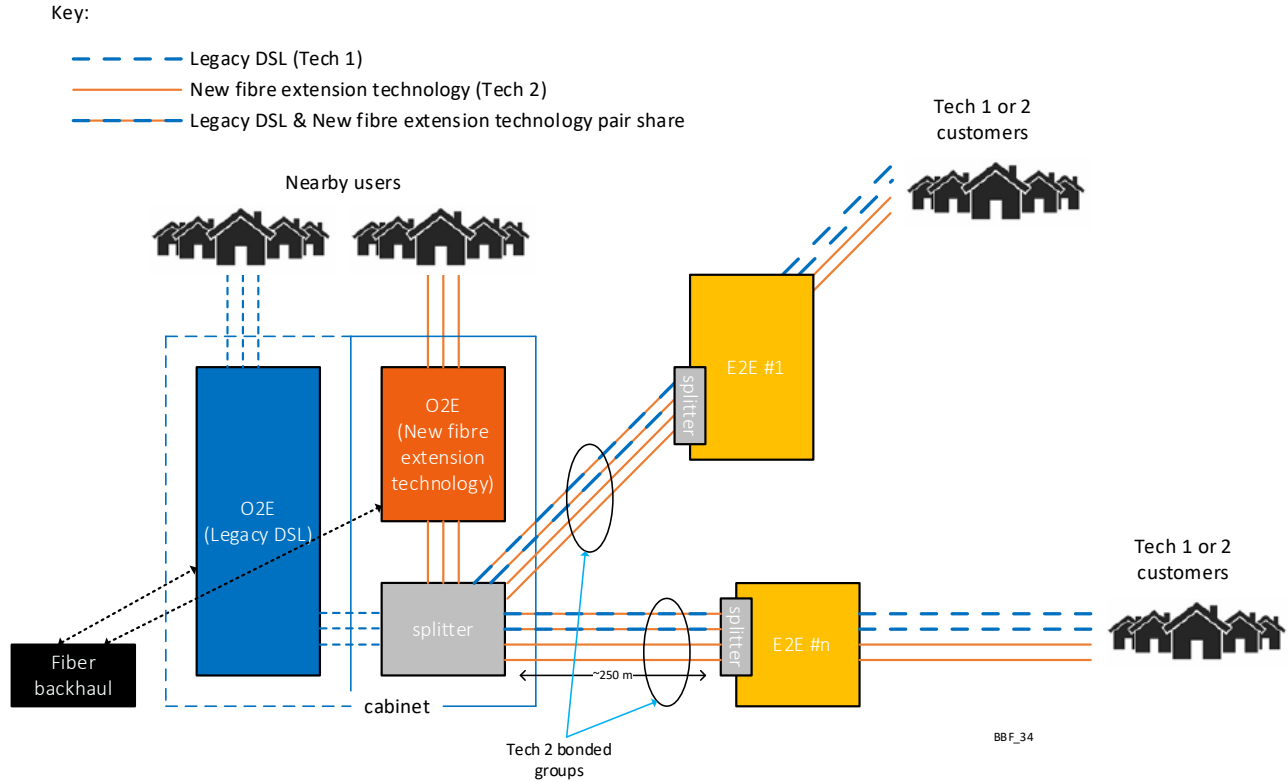

Figure 6-17: High level architecture for the Use Case “Fiber extension by concatenating copper distribution networks (CDNs)- dual use pairs”

6.1.9 Use Case 1a-14 – “Copper to Fiber Backhaul migration”

Table 6-9: Use Case 1a-14

Use Case	Name
1a-14	Use Case 1a-14 – “Copper to Fiber Backhaul migration”

Copper backhauled DPU should also support fiber uplink aiding migration from copper backhaul at a future date and maintaining the value of the network asset. The fiber uplink does not operate concurrently with the bonded copper but acts as an alternative for when fiber coverage is extended. Copper backhaul migration can be applied to other use cases in this text as an alternative for fiber uplink.

Deploying fiber deeper into the network can be cost prohibitive and slow to meet customer demand. But existing cabinet infrastructure can be leveraged to extend coverage of gigabit capable services. By bonding multiple copper pairs backhaul can be provided to more distance DPU without the need to extend the existing fiber footprint. The available capacity to a given end user is now the aggregate capacity from the bonded pairs which is comparable to fiber uplink.

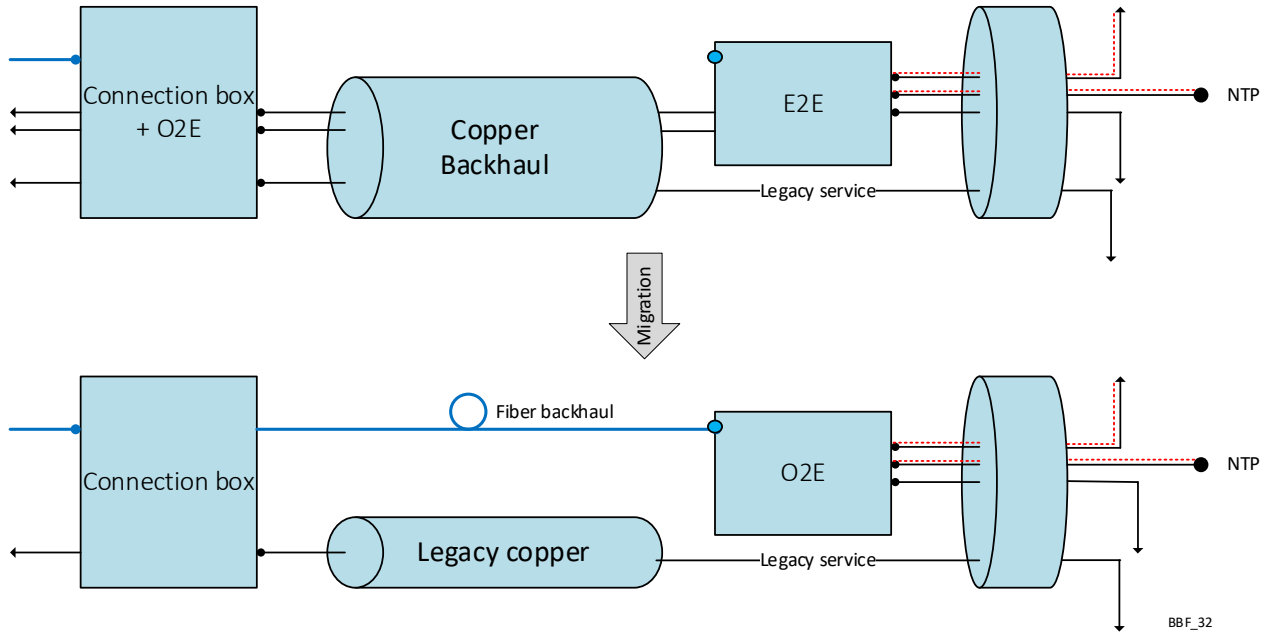

Figure 6-18: Use case - Copper to Fiber backhaul migration

The copper backhaul section extends the capability and capacity of the O2E toward the E2E. The optical to electrical conversion occurs at the O2E after which multiple copper pairs are bonded providing an aggregate backhaul capacity to end customers connected at the E2E. By deploying equipment with both fiber and copper backhaul capability the same device can function as either a E2E or O2E depending on the available uplink connections aiding easy migration. The connection box is a point of flexibility in the operator’s copper network and the location of an O2E providing backhaul capacity.

Services enabled from copper backhauled equipment should be equivalent to those when using fiber uplink. The copper backhaul section operates over the existing telecoms cabling predominantly unshielded multi-pair cable. The backhaul circuits may be fed from multiple cables and not always a single cable binder. The DPU hardware must be capable of supporting fiber backhaul in addition to bonded copper backhaul to aid migration. Copper backhaul may share binders with different services and should coexist with such services without causing undue crosstalk.

Port count of copper backhaul equipment should align to d-side cable sizes. The cable section and copper backhauled equipment is located mid d-side. Powering at copper backhauled device may be combination of local, forward and reverse powering at both ends of bonding group. Forward powering requires sufficient number of spare pairs.

6.2 Use cases Category 1b: Multi-tenant, with shared copper network and individual coaxial cable to the living unit

6.2.1 Use Case 1b-1 – “Point-to-Point Coaxial cabling with frequency diplexers for HSIA and satellite TV in MDU”

Table 6-10: Use Case 1b-1

Use Case	Name
1b-1	Use Case 1b-1 – “Point-to-Point Coaxial cabling with frequency diplexers for HSIA and satellite TV in MDU”

This Use Case is called “Point-to-Point Coaxial with frequency diplexers for HSIA and satellite TV in MDU”. It addresses the situation where a separate coaxial cable to each living unit in an MDU conveys point-to-point HSIA in a lower frequency band and satellite TV signal in a higher frequency band through the use of diplexers.

A satellite coaxial network has a spectrum of 5-2400 MHz of which Satellite is using 950-2150 MHz, so spectrum below Satellite spectrum is available for broadband services.

In the basement or loft is an O2E installed which converts the PON (for example G-PON) signal to high frequency modulated signal by the RF-Transceiver in the O2E. The coaxial network has P2P type of topology to which each MDU apartment Residential Gateway (RGW) is connected by the RGW in-built, or external, Transceiver (TR). Transceiver have a built-in or external passive diplexer filter which filter the signal to TV set or set-top box and the data signal to the RGW. The RF-transceiver have same link speed throughput performance as the incoming G-PON signal. The use case shall deliver Fiber alike services without downgrade. The ONU is a SFP module which converts the optical signal to electrical and the RF-Transceiver and TR is a transparent bridge for the delivered services. It can support CPE management tools as TR-069. DPX is a diplexer filter / combiner which isolate TV band and the RF-Transceiver band and combines the different RF-bands. The O2E can have several RF-ports with individual line to each apartment. The O2E have also management capabilities to manage the coaxial link and L2 support. This Use Case is illustrated in Figure 6-19 using the terminology from Section 4.

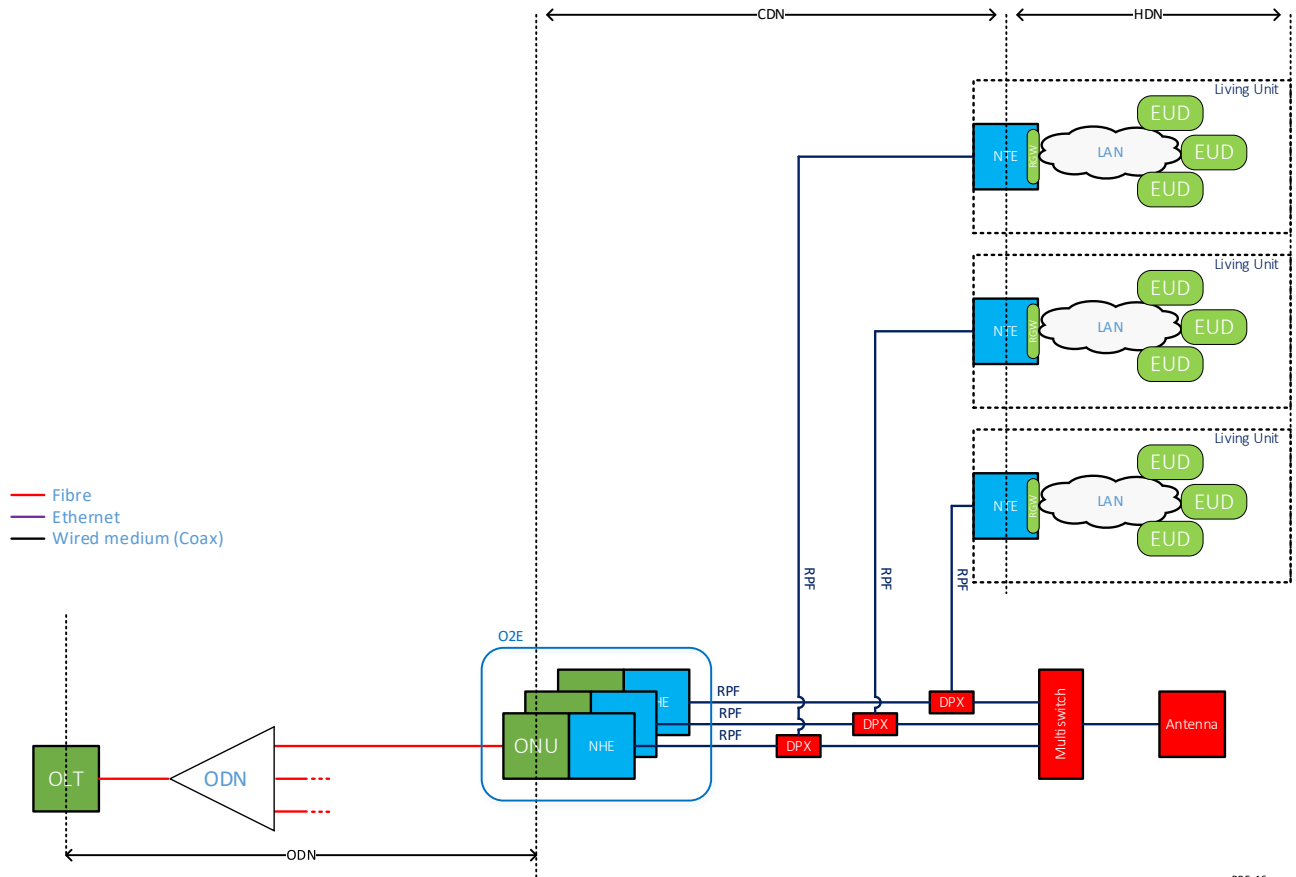

Figure 6-19: P2P Coaxial with frequency diplexers for HSIA and satellite TV in MDU - Use Case 1b-1

The O2E serves multiple living units in a MDU with the O2E located in an equipment room or a cabinet near the MDU. G-PON or XG-PON/XGS-PON fiber connects the O2E to the network. Each O2E RF-Transceiver typically serves one customer, having one RGW connected to the line. Service installation may require a technician visit to the living unit. Coaxial wire length to and within living unit is up to 200 meters. The low-pass port of the premises diplexer connects to the RGW. The high-pass (Satellite TV) port of the premises

diplexer may connect to many wall jacks in the home. Wi-Fi, Ethernet or other LAN in the premises connects multiple CPE to the RGW. A higher frequency band is used to connect Satellite TV amplifier to multiple set-top boxes in each living unit.

6.2.2 Use Case 1b-2 – “Point-to-Point Coaxial cabling for HSIA in MDU”

Table 6-11: Use Case 1b-2

Use Case	Name
1b-2	Use Case 1b-2 – “Point-to-Point Coaxial cabling for HSIA in MDU”

This Use Case is called “Point-to-Point coaxial for HSIA in MDU”. It addresses the situation where a separate coaxial cable to each living unit in an MDU conveys point-to-point HSIA. This Use Case is illustrated in Figure 6-20 using the terminology from Section 4.

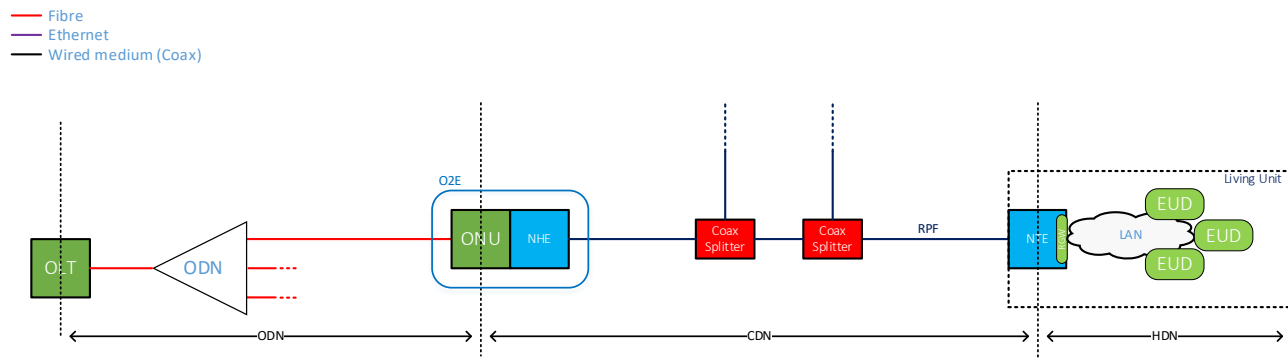

Figure 6-20: P2P Coaxial cabling for HSIA in MDU - Generalized Use Case 1b-2

The O2E serves multiple living units in a MDU with the O2E located in an equipment room or a cabinet near the MDU. G-PON or XG-PON/XGS-PON fiber connects the O2E to the network. Each O2E modem serves one customer, having one NTE/RGW connected to the line. Service installation may require a technician visit to the living unit. Coaxial wire to and within living unit: up to 200 meters of coaxial. The wiring may connect to many wall jacks in the home. Wi-Fi, Ethernet or other LAN in the premises connects multiple CPE to the RGW

6.3 Use Cases Category 2: Exclusively-used cabling outside the living unit

6.3.1 Use Case 2-1 – “Single port Point-to-Point data-grade twisted pair or coaxial cabling”

Table 6-12: Use Case 2-1

Use Case	Name
2-1	Use Case 2-1 – “Single port Point-to-Point data-grade twisted pair or coaxial cabling”

This Use Case is called “Single port Point-to-Point data-grade twisted pair or coaxial”. It addresses the situation where data grade cable is used to extend service into a living unit (SFU or MDU). Generally, the decision to use this architecture is triggered by the cost of the installation constraints (costs, but also burden of setting appointments, customer refusals of drilling, etc...). In this case, it is preferable to reuse pre-existing wiring infrastructure as proposed by this use case however, service provider may choose to deploy new wiring as well, if no suitable wiring is available.

The cabling that is normally use for this extension is:

- Category 5 and Category 6 twisted pair cable
- Coaxial cable

This Use Case is illustrated in Figure 6-21 using the terminology from Section 4.

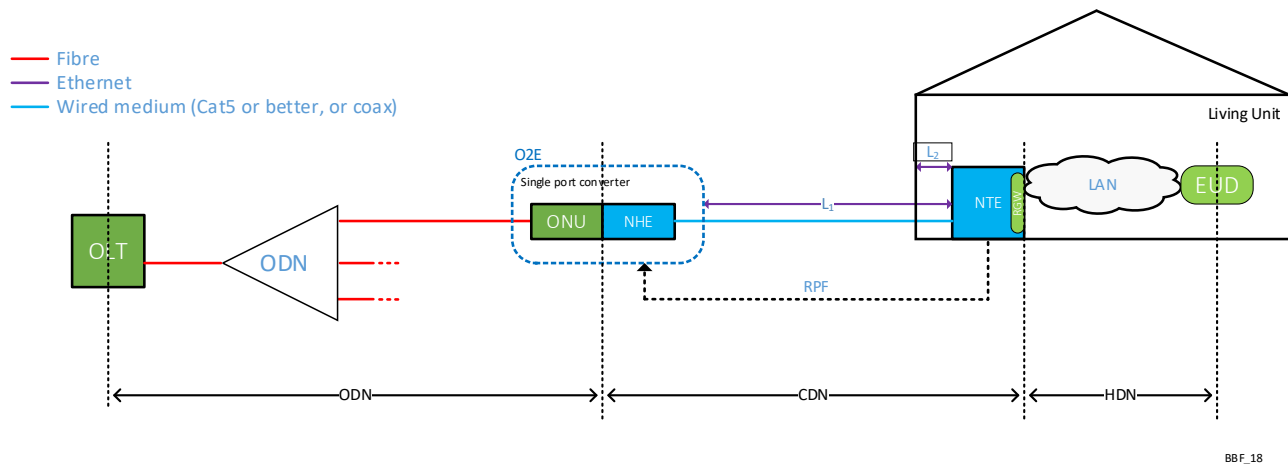

Figure 6-21: Single port Point-to-Point data-grade twisted pair or coaxial cabling - Use case 2-1

General

The single port (O2E) is located near the point-of-entry for the premises (in a NID or just inside the living unit). Even if some deviations may occur, L2 and L1 are normally very short, allowing peak rates over the copper. Typically, L1 will not be longer than 200 m while L2 may vary between 0 and some tens of meters. Normally, G-PON or XG-PON/XGS-PON fiber connects the single port converter to the network (but other types of deployment like P2P fiber are also possible). The transceiver located in the single port converter (NHE – Network Header Entity) serves one customer. An O2E makes the connection to the copper-based network through an NHE that performs PHY-layer protocol adaptation. On the user side, a unique NTE (Network Termination Entity) is connected to the line. This NTE, may incorporate a RGW. Wi-Fi, Ethernet or other LAN in the premises connects multiple EUDs.

Performance

Due to the short distance and the P2P nature of the copper-based link (CDN), the speeds achieved (> 1 Gbps) are above the ones offered by traditional FTTH deployments. Therefore, the in-home link is not a bottleneck for the overall service.

Interference with neighbors

If multiple Single Port Converters (O2E) are physically located close to each other, there may be some crosstalk between lines and interference mitigation/cancellation techniques may be needed to provide each user with the agreed services. The type of technique will depend on the constraints in each deployment, physical media and the technology used.

6.3.2 Use Case 2-2 – “Multiple port Point-to-Point data-grade twisted pair or coaxial cabling”

Table 6-13: Use Case 2-2

Use Case	Name
2-2	Use Case 2-2 – “Multiple port Point-to-Point data-grade twisted pair or coaxial cabling”

This use case addresses the situation where individual homes are connected to the fiber network (FTTH) and because of the installation constraints (costs, but also burden of setting appointments, customer refusals of drilling, etc.), it is preferable to reuse pre-existing wiring infrastructure.

In this case, the optical termination is reused between different users. A switching unit is needed in order to address the correct customer.

This Use Case is illustrated in

Figure 6-22 using the terminology from Section 4.

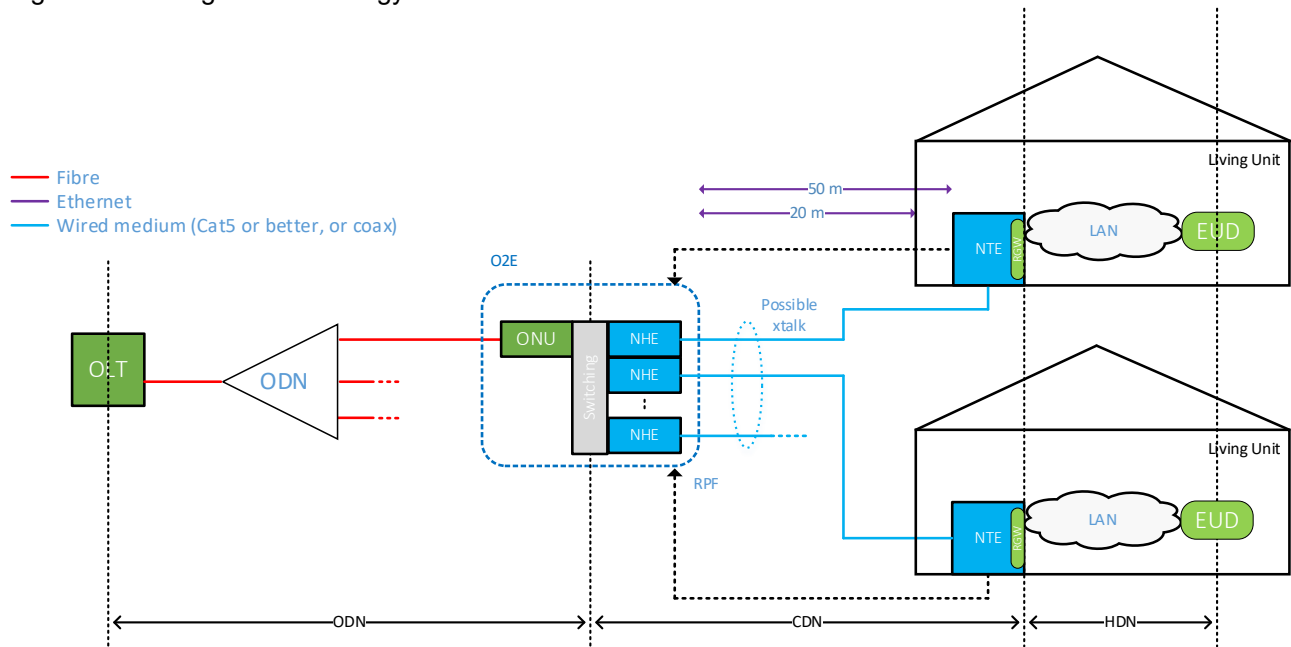

BBF_19

Figure 6-22: Multiple port Point-to-Point data-grade twisted pair or coaxial cabling – Use case 2-2

In this use case, an optical fiber from an ODN (usually a PON-based technology, but P2P fiber is also possible) is connected to an O2E box located in an outside cabinet (or internal to the premises close to the point of entry into the premises). This box may make use of reverse power feeding.

Within the O2E, an ONU terminates the optical access segment and is connected to several NHEs that convert the signal to a different wired medium using an adapted PHY-layer protocol (e.g., G.hn). Since several transceivers are connected to the optical termination unit, a switching unit is needed in the O2E box. Note: This O2E is similar to a DPU. However, the amount of functions to be implemented need to be determined. In this use case a low-cost approach is expected.

Every wired transceiver within the O2E is connected through the local in-home wiring to another wired transceiver that is located close to the residential gateway inside the home. This local wiring is pre-existing to the installation and can be any of the physical medium commonly found in deployments (coaxial or phone line). During the installation, the most convenient wiring can be identified and connected depending on the availability (e.g., because of coexistence issues) and performance requirements (e.g., throughput).

Therefore, in this use case the part of the access connection that is internal to the premises does not need any infrastructure deployment since it reuses already existing cabling. The in-home wired transceiver is connected (normally through a high-speed Ethernet link) to the residential gateway. From the gateway, the flows are distributed through a LAN to the user through a normal LAN network.

In terms of performance, due to the short distance and the P2P nature of the in-home link, the speeds achieved (> 1 Gbps) are above the ones offered by traditional FTTH deployments. Therefore, the in-home link is not a bottleneck for the overall service. In this sense, the in-home segment will really be an extension of the optical access network without limiting its characteristics. Since the O2E includes several transceivers, there may be some crosstalk between lines and interference mitigation techniques may be needed to provide each user with the agreed services.

Appendix I. FTTEp using technology MoCA Access

I.1 Introduction to MoCA Access Technology

MoCA Access 2.5 is a technology defined by Multimedia over Coax Alliance for access applications. MoCA Access 2.5 is defined to operate over coaxial cable and use selectable spectrum in the range between 400 to 1675MHz, allowing the technology to coexist with pre-existing services (e.g, DOCSIS).

MoCA Access systems can pass data at very high speeds, up to at least 2.5 gigabit per second.

MoCA Access 2.5 specification consist of a physical layer (PHY) and media access control link layer (MAC). MoCA original application was solving home-networking challenges, as a mesh network. The technology was later extended to MoCA Access 2.5 for access applications.

The main characteristics of the technology are summarized in Table I-4:

Table I-14: MoCA Access 2.5 technologies summary

Area	Sub-area	Coaxial Cable
Physical Layer	Point-to-Point or Point to Multipoint	YES
	Max number of clients	63
	Max modulation Scheme	OFDM 1024 QAM
	Roundtrip average Latency	6ms
	Channel size MHz	5x100MHz
	Channel location	400-1675 MHz
	Coexist with TV and DOCSIS	YES
MAC Layer	MAC rate downstream	2500 Mbit/s
	MAC rate upstream	2000 Mbit/s
	Security key management	802.1X
	Encryption	AES 128 bits
	Quality of Service (QoS)	Up to 8 queues
	Medium access	TDMA
	Management	SNMP, TR-181

I.2 Definitions

This section is intentionally left blank.

I.3 Abbreviations

This Appendix uses the following abbreviations:

- AES** Advanced Encryption Standard
- DHCP** Dynamic Host Configuration Protocol
- DNS** Domain Name System
- DOCSIS** Data Over Cable Service Interface Specification
- EMA** Element Management Agent
- GEM** GPON Encapsulation Method
- GPON** Gigabit Passive Optical Networks
- IGMP** Internet Group Management Protocol

MAC	Medium Access Control
MoCA	Multimedia over Coax Alliance
MAP	Medium Access Plan
MDU	Multi Dwelling Unit
MIB	Model Information Base
MLD	Multicast Listener Discovery
NC	Network Controller
NETCONF	Network Configuration Protocol
NMS	Network Management System
NPER	Nominal PER
OAM	Operation And Management
OFDM	Orthogonal Frequency-Division Multiplexing
OSS	Operations Support Systems
P2P	Point To Point
P2MP	Point To Multipoint
PADI	PPPoE Active Discovery Initiation
PER	Packet Error Rate
PHY	Physical Layer
PPPoE	Point-to-Point Protocol over Ethernet
QAM	Quadrature Amplitude Modulation
RLAPM	Receive Label Added PHY Margin
SAP	Service Access Point
SAPM	Subcarrier Added PHY margin
SFU	Single Family Unit
SNMP	Simple Network Management Protocol
TCP	Transport Control Protocol
TDMA	Time Division Multiple Access
TLS	Transport Layer Security
TLV	Type-Length-Value
TPC	Transmit Power Control
VID	VLAN Identification
VLAN	Virtual Local Area Network
VLPER	Very Low PER
XGS-PON	10 Gigabit Symmetrical Passive Optical Networks

I.4 References

Document	Title	Source	Year
[1] MoCA Access 2.5 for the Broadband Forum	<i>MoCA Access Specification v2.5</i>	MoCA Alliance	2019
[2] TR-301 Issue 2 Amendment 1	<i>Architecture and Requirements for Fiber to the Distribution Point</i>	BBF	2020
[3] TR-101 Issue 2	<i>Migration to Ethernet-Based Broadband Aggregation</i>	BBF	2011
[4] TR-178 Issue 2	<i>Multi-service Broadband Network Architecture and Nodal Requirements</i>	BBF	2017
[5] TR-156 Issue 4	<i>Using GPON Access in the context of TR-101</i>	BBF	2017
[6] TR-167 Issue 3	<i>GPON-fed TR-101 Ethernet Access Node</i>	BBF	2017
[7] TR-181	<i>Device Data Model</i>	BBF	2019

I.5 Deployment models using MoCA Access technology

This section describes following use cases described in Section 6.1.3:

Table I-1: MoCA Access Use Cases

Use Case	Name	Clause
1a-3	Use Case 1a-3 – “MDU Coaxial Cable services co-existing with the TV service”	1.5
1a-4	Use Case 1a-4 – “MDU Coaxial Cable services co-existing with the Cable-TV and DOCSIS services”	1.5
1a-5	Use Case 1a-5 – “MDU Coaxial Cable services using full coaxial spectrum”	1.5

These use cases are typically deployed in following extension points (FTTep):

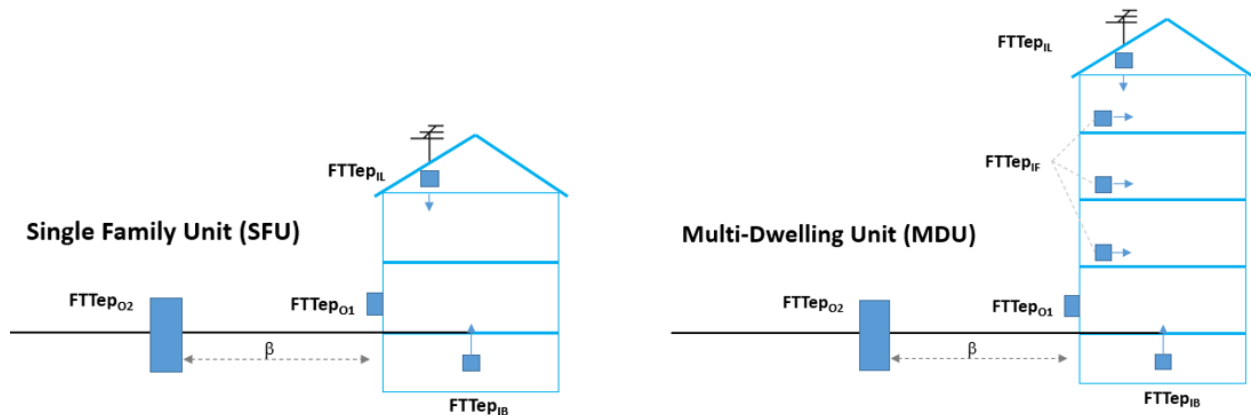

Figure I-1: Typical deployment of MoCA Access where β in existing coaxial networks can be up to 100 meters

Deployment point description:

- **FTTep_{O2} coaxial outdoor cabinet/manhole** - This can typically be in existing coaxial networks located up to 100 meters from the SFU or MDU building located in a cabinet or manhole and have coaxial infrastructure available

I.6 Requirements

This Appendix provides the architectural basis and technical description of how to deploy MoCA access over the FTTep use cases within a TR-101 and/or TR-178 architecture.

I.7 Architectural and Topological Aspects

All coaxial networks have a passive coaxial network entry point after TV amplifier (located outside or inside the building) which is called FTTep. SFU or MDU building can have either star or a trunk with tap or splitter

coaxial network topology. If the topology is star type, then it is possible to have P2P connection. In MDU with P2P star topology each apartment is reached with own wired connection from the entry point. In MDU with P2MP are all apartments sharing the same coaxial trunk cable. Reversed power feed is currently only possible in coaxial networks with P2P topology.

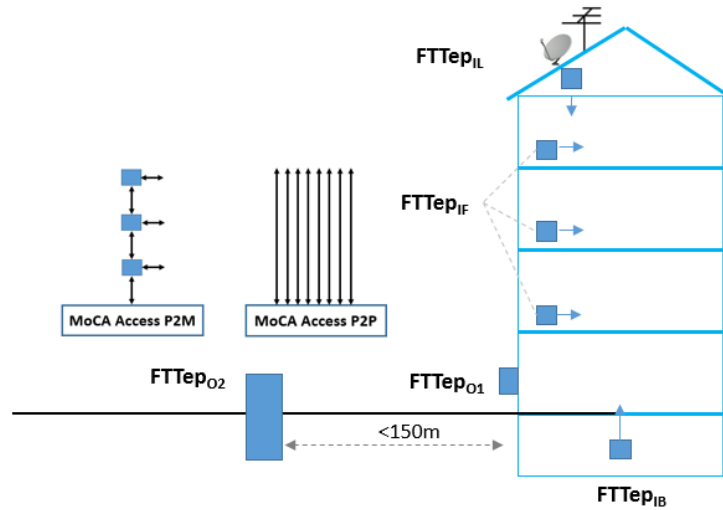

Figure I-2:: MoCA Access can be deployed with P2MP or P2P topology from above FTTEP locations depending of existing coaxial network structure

I.8 Environmental Aspects

O2Es can be deployed in environmentally challenging locations such as pole mounts, outside building wall mounts, and underground chambers. Therefore, temperature and humidity extremes as well as physical security need to be considered in O2E implementations. Additionally, with the potential for large number of geographically locations of O2E deployed in networks, visits by service provider technicians should be kept to a minimum.

MoCA Access deployments have no climatic and biological impact neither have chemically and mechanically active substances. The power consumption of the O2E itself needs to be as low as possible. This usually means passive cooling with thermal management without generating noise emissions.

I.9 Powering (and reverse powering)

Typically, an O2E is installed beside the in-building TV amplifier which is powered locally. If installation is floor based in a MDU raiser power is not always available. Providing local power to O2E under such circumstances becomes problematic due to the need to gain power utility access, and provide power functionalities such as surge suppression and, in some cases, battery backup. A solution to this problem is to power these O2Es over the coaxial network from the customer premises. Since O2Es often serve more than one customer premises, they should be able to equitably distribute the power drawn from multiple NTEs. Additionally, O2Es shall have the ability to operate the northbound transceiver when only one NTE is providing power.

Powering O2E over coaxial networks results in additional requirements e.g., the O2E needs to know the state of the remote power source. Changes in power source state such as the transition to and from battery backup, and impending total loss of power is communicated to the O2E. Upon receipt of these state change notifications, the O2E may need to respond with internal actions, such as the reduction of power consumption while operating on power from battery backup. Further, the power source has the ability to detect the presence of an O2E, the absence of fault conditions (e.g., short or open circuit), and that there are no other NTE connected devices on the pair before applying power, thereby avoiding damage to other equipment.

In order to support reverse power feeding in P2P coaxial networks (P2MP coaxial network reverse power feed is currently not standardized) ETSI TS 101-584-1 defines the metallic detection startup (MDSU) protocol based on the detection of resistive signatures located in the O2E. ETSI TS 101-584-1 defines the POTS Remote Copper Reconfiguration Protocol (PRP), an optional extension of MDSU in case this functionality is required. Detailed specifications are defined in ETSI TS 101-584-1. Different service provider implementation options are described in section 5 of ETSI TS 101-584-1. Same protocol is possible to use over P2P coaxial networks.

I.10 Physical interfaces

An O2E contains two types of physical interfaces used for data transport by the O2E:

1. Northbound backhaul interface(s) that connects the O2E to the higher order network.
2. Southbound coaxial drop interfaces that provide the user broadband service.

I.11 Northbound

An O2E have a fiber backhaul with a minimum bandwidth of 1 Gbps in both the upstream and downstream directions and it should support a fiber backhaul with a maximum bandwidth of 10 Gbps in both upstream and downstream directions. If O2E have more than 16 NTEs then it should support a second uplink interface. Both northbound interfaces are of the same type and speed and support Link Aggregation.

I.12 Southbound

An O2E have minimum of one southbound 75Ω coaxial link port and maximum of 24 southbound 75Ω coaxial link ports. On each coaxial port it can have between 1 to 63 NTE's connected. Coaxial port signal level can have three so called Power Contours, PC1, PC2 or PC3 supporting signal levels between 7dBm, 17dBm or 27dBm. Power Contour 2 is the most commonly use level due to coaxial passive components signal level limitations of 125dBμV.

I.13 Traffic Management and QoS

The link rates, both on the southbound and northbound side, and service mixes led to the conclusion that having differential packet treatment with regarding to queuing and forwarding in the O2E do not lead to jitter. Typically, northbound interface has same or less capacity than the accumulated capacity of the southbound ports. The accumulated coaxial link throughput capacity can be configured dynamically to provide symmetrical or asymmetrical traffic flows. O2E should have 8 levels of traffic priority per direction and 8 shared strict queues in the upstream direction and 8 strict priority queues in the downstream direction per MoCA southbound port. A MoCA southbound port can have one P2P NTE or up to 63 NTE's in P2MP topology. A virtual Ethernet interface is used to represent the interface between O2E and NTE with either P2P or with P2MP with one or up to 63 virtual ports sharing 8 priority queues.

The O2E is mainly a Layer 2 device and so packet classification is done on the basis of VID and/or .1p bit value along with the ability to apply VID and .1p bit values at the user port based on a limited set of criteria. O2E receives upstream frames from the U reference point interface, adds or translates VLAN tags, and forwards them to the appropriate virtual queue. The O2E backhaul then performs any required uplink specific adaptation and forwards the frames over the uplink. Downstream frames are placed in the appropriate virtual priority queue by the O2E backhaul and the O2E places the frame into the correct physical priority queue at the U reference point interface. During the forwarding of the downstream frames, the O2E removes or translates tags. Frame forwarding actions of the O2E are provisioned by the EMA. Frame forwarding actions of the O2E backhaul are provisioned by the higher order of networks as required.

I.14 VLAN Handling

The O2E supports 1:1 VLANs in the upstream direction, the O2E always adds one or two tags to untagged frames, or translates an incoming tag, or translates an incoming tag and add a tag.

- For single-tagged VLANs at the V reference point, the O2E is provisioned to either add a S-tag, or match and translate an incoming tag into a S-tag.
- For double-tagged VLANs at V reference point, the O2E is provisioned to either add a C-tag to untagged traffic, or match and translate a single tag into a C-tag, then add the S-tag.
- For the case where the VLANs are double-tagged at the U reference point, the O2E is provisioned to match and translate the outer tag into a S-tag.

These tagging operations are provisioned on a per NTE basis. The mapping of upstream frames to upstream priority queues is based upon the VID and/or p-bit value in the frame tag after the tag manipulation has occurred.

In the downstream direction the O2E needs the ability to remove or translate tags on a per user port basis. In this case, the mapping of downstream frames to downstream queues is based on frame tag VID and/or p-bit values prior to tag manipulation.

In all cases, the addition, removal, or translation of frames is performed based on a limited but arbitrary combination of criteria provided by the EMA.

I.15 Multicast

O2Es support both IGMP and MLD functionality based on RFC 4604. As RFC 4604, the following requirements use the term GMP to indicate both IGMP and MLD.

Note: Transparent forwarding of GMP messages in N:1 VLANs might result in network flooding and is therefore discouraged.

Note: IGMP V3 report messages may carry membership information for multiple multicast groups. Therefore, a single IGMP report message may carry membership information on groups “matching” a multicast VLAN as well as on groups “not matching” a multicast VLAN.

I.16 Ethernet OAM

O2Es may be located in fairly inaccessible locations as basements, electrical raisers or loft and are sealed units. Therefore, fairly comprehensive OAM and diagnostics functions are needed to allow remote management to determine the location and possible nature of a problem.

Ethernet OAM can be used to determine connectivity/reachability and some aspects of performance. The below requirements support one-off, on-demand reachability tests, periodic connectivity monitoring via continuity checks (CCs), and the loopback of user traffic for performance and data integrity testing.

When point-to-point Ethernet or TR-167 compliant G-PON backhaul are used following requirements apply to O2Es deployments. O2Es deployments provide Ethernet OAM support in the O2E backhaul and must comply with the OAM requirements defined in TR-156.

I.17 Relay Agent and Intermediate Agent Operation

The Relay Agent (RA) and Intermediate Agent (IA) functions provide the ability to insert port information in upstream session initiation requests arriving at the user port of an O2E. Examples of these requests are PADI for PPPoE and Discovery messages for DHCPv4 and v6. This information is derived from preconfigured information elements associated with each user port. These information elements contain strings that may assign port/customer identifiers that are dependent on an operator’s conventions.

The Element Management Agent (EMA) functions provide the ability to insert port information in upstream session initiation requests arriving at the user port of an O2E. Examples of these requests are discovery messages for DHCPv4 and v6. This information is derived from preconfigured information elements associated with each user port. These information elements contain strings that may assign port/customer identifiers that are dependent on an operator’s conventions.

O2Es may be distributed systems, with distributed ONUs, shelves, or modules that attach to one another and present the management view of a single, distributed system.

When O2E deployment use a TR-156 compliant backhaul that permits the high order network to have visibility of user port information through their one to one association with GEM ports. Therefore, the EMA functions are performed in the high order network.

As the MoCA Access Network can be P2P Ethernet link / port or P2MP and shared by multiple subscribers, it is required to describe the access loop with a virtual link or port. For example (taken from R-127/TR-156 and extended to fit a shared media access network like MoCA):

- *High Order Network-Access-Node-Identifier eth Slot/Port/ONUID/Slot/Port/Virtual Port[:VLAN-ID] or*
- *High Order Network-Access-Node-Identifier eth Slot/Port/ONUID/Slot/Port[:VLAN-ID] The virtual port could be the modem MoCA MAC address and the Ethernet interface index in the modem, e.g., "84930c006286_1", alternatively:*
- *High Order Network-Access-Node-Identifier eth Slot/Port/ONUID/Slot/Port/ModemMACAddress/ModemPort[:VLAN-ID]*

The resulting syntax is different from the syntax used by O2Es in a TR-167 deployment. In accordance with TR-167, the access loop logical port syntax relates to the parameters of the O2E. For example: *O2E-Access-Node-Identifier Slot/Port[:VLAN-ID]*

In some cases, it may be desirable for O2Es in a TR-156 deployment to use an access loop syntax that relates to the parameters of the O2E instead of the high order network. To do this, a one-to-one mapping is needed between the ONUID used by the high order network, the logical association towards the O2E, and the O2E port identifier. Such association can be done by the management layer. It could also be done by the network elements; however, the detailed specification is beyond the scope of this document.

O2Es in a TR-167 and higher order networks in a TR-156 deployment must comply with section 5.4.7 of TR-178.

An O2E using MoCA 2.5 PHY in 3-channel operation MUST support:

As an ingress node with one Flow, a total MAC Rate of at least the minimum of 1.5 Gbps and 90% of the maximum throughput which its industry standard interface can support.

As an Egress Node with one Flow, a total MAC Rate of at least the minimum of 1.5 Gbps and 90% of the maximum throughput which its industry standard interface can support.

As an ingress and Egress Node, and with one Flow in each direction, an aggregated MAC Rate in both directions of at least the minimum of 97% of 1.5 Gbps and 90% of the maximum throughput which its industry standard interface can support in both directions. This must be achieved for any ratio of traffic between ingress and egress traffic.

An O2E MoCA 2.5 PHY in 4-channel operation MUST support:

As an ingress node with one Flow, a total MAC Rate of at least the minimum of 2.0 Gbps and 90% of the maximum throughput which its industry standard interface can support.

As an Egress Node with one Flow, a total MAC Rate of at least the minimum of 2.0 Gbps and 90% of the maximum throughput which its industry standard interface can support.

As an ingress and Egress Node, and with one Flow in each direction, an aggregated MAC Rate in both directions of at least the minimum of 97% of 2.0 Gbps and 90% of the maximum throughput which its industry standard interface can support in both directions. This must be achieved for any ratio of traffic between ingress and egress traffic.

An O2E using MoCA 2.5 PHY in 5-channel operation MUST support:

As an ingress node with one Flow, a total MAC Rate of at least the minimum of 2.5 Gbps and 90% of the maximum throughput which its industry standard interface can support.

As an Egress Node with one Flow, a total MAC Rate of at least the minimum of 2.5 Gbps and 90% of the maximum throughput which its industry standard interface can support.

As an ingress and Egress Node, and with one Flow in each direction, an aggregated MAC Rate in both directions of at least the minimum of 97% of 2.5 Gbps and 90% of the maximum throughput which its industry standard interface can support in both directions. This must be achieved for any ratio of traffic between ingress and egress traffic.

An O2E using MoCA 2.5 PHY in 5-channel operation MUST support:

As an ingress Node with one Flow, a total MAC Rate of at least the minimum of 2.0 Gbps and 90% of the maximum throughput which its industry standard interface can support.

As an egress Node with one Flow, a total MAC Rate of at least the minimum of 2.5 Gbps and 90% of the maximum throughput which its industry standard interface can support.

As an ingress and egress Node, and with one Flow in each direction, an aggregated MAC Rate in both directions of at least the minimum of 97% of 2.5 Gbps and 90% of the maximum throughput which its industry standard interface can support in both directions. This is achieved for any ratio of traffic between ingress and egress traffic and the ingress traffic is no more than 2.0 Gbps.

Note: When sending bidirectional traffic, an additional 3% fragmentation overhead is allowed.

The O2E must be able to schedule through the network all the transmissions requested by the Ingress Node to meet the minimum MAC Rate requirements of this section, if the available time on the wire, assuming the maximum allowed MAP cycle, is enough to accommodate these transmissions requests.

The above minimum MAC Rate requirements apply under the following conditions:

- The cable plant response is Flat Channel
- The received signal level at each Node is at least -40 dBm per 100 MHz channel
- The PER_2.5MODE is set to NPER
- There are between 1 and 63 Client Nodes in the network
- All Nodes are in Power State M0
- RLAPMEN and SAPMEN are both set to DISABLED in all Nodes
- Ethernet frames for all data traffic is of size E_{max}
- Packets are presented for transmission at the ingress Node’s MAC SAP at a constant packet rate with jitter less than +/-1us
- There is no other data traffic on the network

I.18 MoCA specific Type-Length-Values (TLVs)

The MoCA MIB is comprised of tabular objects (i.e., tables) for status reporting and configuration of the managed MoCA interfaces. In addition, notifications are also defined to allow dynamic recording and/or reporting exceptional conditions or events that may warrant immediate action by the network management system. The MIB objects defined in this document are intended to be used by MoCA interfaces that support MoCA Access Specification v2.5. Following MoCA specific TLVs are used:

Table I-2: MoCA specific TLVs

Sub-TLV	Message Type	Information	Reference
255	Target PHY Rate of the MoCA Node when TPC is NPER	Reports the expected maximum PHY data rate with NPER configuration	mocalfTpcTargetRateNper
254	Target PHY Rate of the MoCA Node when TPC is VLPER	Reports the expected maximum PHY data rate with VPER	mocalfTpcTargetRateVlper
253	Expected max MAC data rate upstream	Reports the expected maximum MAC data rate upstream	ifHCOOutUnicastPkts
252	Expected max MAC data rate downstream	Reports the expected maximum MAC data rate downstream	ifHCOOutBroadcastPkts
251	Maximum number of priority levels that the Access NC can support	Reports maximum number of priority levels that the Access NC can support	mocalfNumPriority
250	List of items instructing the Access NC of the maximum percentage of the wire time allowed to	Reports maximum percentage of the wire time allowed to each priority level	mocalfPerCentPriority

	each priority level		
--	---------------------	--	--

I.19 Diagnostics

The ability to maintain a quality customer experience over time requires the ongoing collection of data on various aspects of O2E performance. These include but are not limited to: user Ethernet frame counts and MoCA Access PHY/MAC data. The O2E is responsible for keeping the current and the previous 15-minute interval for each performance monitoring counter. All other history counters beyond the previous interval are maintained in the EMA.

I.20 Network Management

An O2E may have one of several different uplink technologies. These include but are not limited to G-PON, XG-PON/XGS-PON and point-to-point Ethernet. While these uplink technologies all include their own embedded management interfaces, expanding those interfaces to include common O2E management functions would result in a unique management interface per uplink technology. This increases complexity in large deployments that use a mix of uplink technologies. It can also increase the complexity of O2Es that use small form factor pluggable uplink transceivers by causing the management interface to change with the transceiver. This mix of possible O2E management interfaces would also make interoperability difficult to achieve since it would require a unique interoperability-testing ecosystem for each uplink technology. For these reasons, an O2E management architecture that uses a single, uplink technology agnostic management interface has been defined. Figure I-3 describes the general management model for MoCA Access.

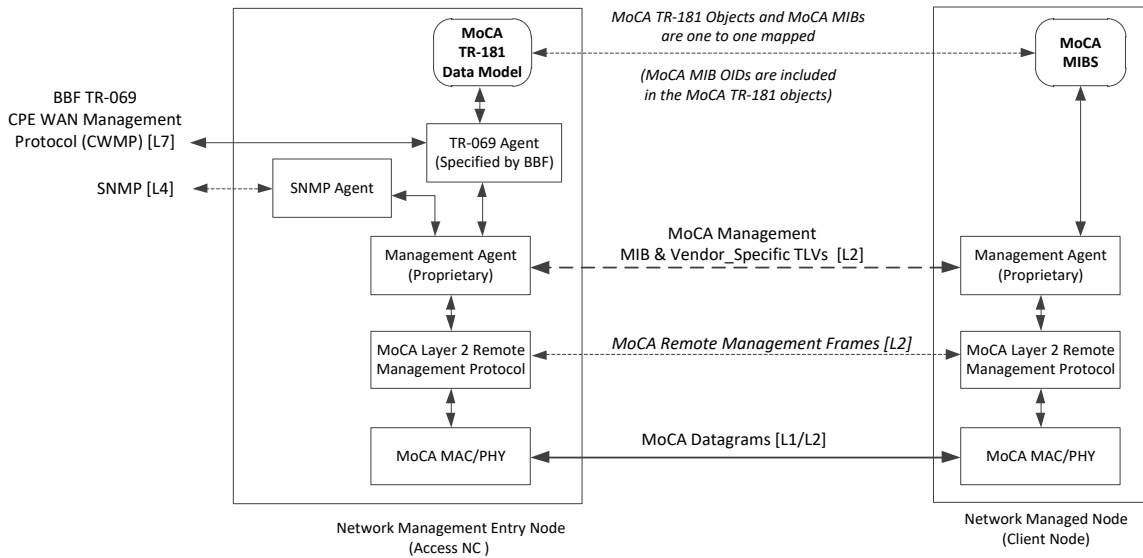

Figure I-3: MoCA Access management proxy model

In this architecture, there is a SNMP Element Management Agent (EMA) which aggregate from each O2E MIB messages to higher order management systems. The EMA and aggregation functions may be realized as part of an EMA server that manages multiple O2Es, an intermediate system that aggregates EMAs residing on lower order systems, or as part of the NMS function. They may also be implemented as virtualized functions on one or more network virtualization infrastructures.

While the management of uplink specific functions remains uplink technology specific, the management of common O2E functions is accomplished using a single management protocol and data model. Figure I-4

depicts the functional split from a TR-167 O2E management domain perspective with P2MP virtual modem Ethernet or P2P modem Ethernet ports.

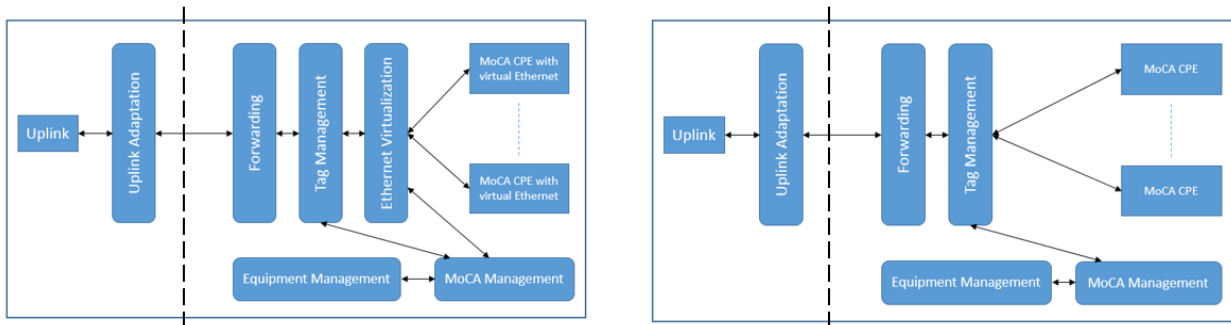

Figure I-4: TR-167 Management Domians with either P2MP virutal modem Ethernet or P2P modem Ethernet ports.

Figure I-5 depicts the functional split from a TR-156 O2E management domain perspective with P2MP virtual modem Ethernet or P2P modem Ethernet ports.

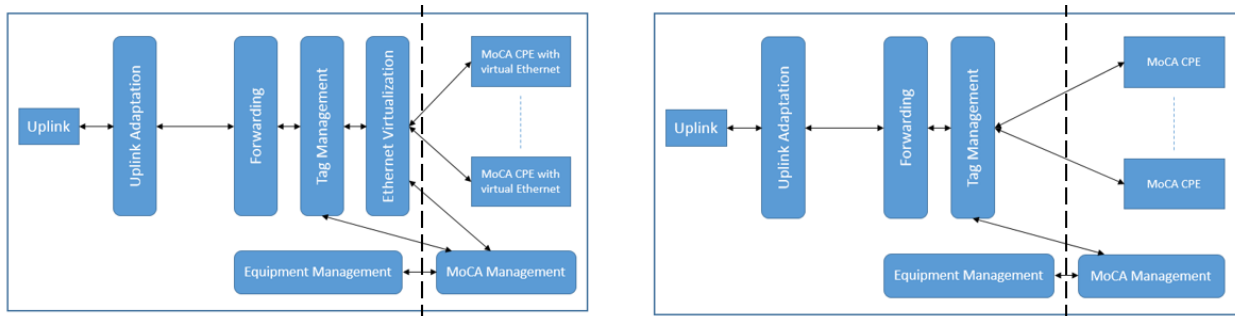

Figure I-5: TR-156 Management Domians with either P2MP virutal modem Ethernet or P2P modem Ethernet ports.

I.21 EMA Concepts

The fundamental purpose of the EMA is to allow the OSS/NMS to perform operations on a given O2E whether or not that O2E is currently accessible. This includes the following:

- Firmware download and management
- Initial provisioning
- Configuration
- Test and diagnostics
- Statistics gathering
- Event reporting

Of course, some of these operations have limited capabilities when the O2E is without power. For example, statistics gathering is limited to the history stored in the EMA Aggregation since the current information is not available from the O2E.

The OSS/NMS still needs to be able to ascertain the true power state of the O2E as a whole, and of each given coaxial link, for example for diagnostics purposes. It can choose to take into account the power state of an O2E for various processes, e.g., a new firmware download, but this is not required.

The EMA is purely a functional entity and is not tied to any single platform or location. It may be hosted anywhere within a service provider’s network that is always powered. The EMA may be deployed on the high

order network, a NMS, OSS or as a cloud-based service. For example, a given service provider may choose to deploy the EMA within the OLT that is acting as the high order network for an O2E.

The EMA Aggregation assumes that there is a secure transport layer available to the O2E. This means that tasks such as O2E fragmentation and retransmission are assumed to occur in protocol layers below the actual management protocol.

The EMA introduces a new concept of a pending action. When the OSS/NMS attempts to carry out an action that needs the O2E to be powered up to be completed, the EMA acknowledges receipt and understanding of the action, but does not indicate it as complete until it has actually happened, i.e., when the O2E is next powered up. When a failure (e.g., power failure) occurs in the course of an O2E firmware upgrade, the EMA should gracefully recover.

I.22 O2E-EMA Discovery and NETCONF Session Establishment

When an O2E is powered up it needs to discover the correct EMA with which to associate. Both the installation process and EMA discovery must be supported without requiring manual configuration of IP addresses or other parameters in the O2E. EMA discovery requires the following steps:

- Upon powering up, an O2E creates a link-local IPv6 address on its management interface. The O2E sends an O2E Discover formatted as a set of options within a DHCPv6 Information-request message to discover the address of the EMA to which it should establish a connection. The O2E may also send other IPv4 DHCP and/or DHCPv6 messages to discover EMA Information and to establish a routable IPv4 or IPv6 address for the O2E.

O2E shall also support DHCPv6 configuration in conjunction with stateless autoconfiguration of IPv6 prefix:

- A DHCP/DHCPv6 server responds to an O2E Discover with an EMA Offer, which embeds the required EMA Information as sub-options within a DHCP or DHCPv6 message.
- The O2E initiates a TCP connection to the EMA as defined in NETCONF Call Home and RESTCONF Call Home RFC 8071. The EMA responds by initiating TLS to the O2E. As part of the TLS session initiation, the O2E and the EMA authenticate each other.
- The EMA initiates a NETCONF session over the established TLS session.

These steps are defined in detail in the following subsections.

I.23 Use of DHCP

DHCP plays a central role in O2E-EMA discovery, as the DHCP (or DHCPv6 or stateless DHCPv6) server provides the EMA reachability information to the O2E. Since the O2E to EMA mapping is client-specific, the DHCP server needs access to the mapping information. The mapping mechanism is out of scope; however, several example mechanisms are shown below:

- DHCP Relay may be used to relay O2E Discover to a centralized server associated with a network management database where the mapping is performed.
- The DHCP/DHCPv6 server may use a different out of scope mechanism to communicate with a centralized network management database where the mapping is performed.
- The DHCP/DHCPv6 server may be pre-configured with the subset of O2E-EMA mappings required for a localized network scope.

A DHCP or DHCPv6 or stateless DHCPv6 server used for O2E-EMA discovery must support client-specific mapping of each O2E to its EMA.

If the O2E and EMA are within the same Layer 2 broadcast domain, they can communicate using IPv6 link-local IP addresses and there is no need for the O2E to establish a routable IP address. Otherwise, the O2E

establishes a routable IPv4 or IPv6 address (using SLAAC, DHCPv6 or DHCP) to communicate with the EMA.

The EMA Information sub-option used to convey EMA reachability information includes fields for Domain name, IPv4 and IPv6 addresses. While the address version used will typically match the DHCP version, there are valid exceptions. For instance, IPv6 link-local addressing may be used for O2E-EMA communication in a management network that uses IPv4 for other applications including DHCP.

In some deployment scenarios, more than one EMA may be offered to the O2E by the DHCP server. For example, a deployment that centralizes EMAs in a network data center may have a pool of available EMAs, any of which may be assigned to an O2E. If multiple EMAs are offered, the O2E attempts to establish connections to them in the order in which the EMAs are listed in the EMA Offer message. In other scenarios, the EMA's IP address may be resolved from the domain name using DNS in order to support EMA clustering, load sharing, or other features.

For TR-069 management shall same IP address assignment apply where ACS acts as a DHCP server.

I.24 O2E Identification

The O2E must identify itself to the DHCP server so it can be mapped to the correct EMA. The O2E Discover message provides two mechanisms to do this. The first mechanism is the DHCP Unique Identifier (DUID) as defined in RFC 3315, which provides an identification code that is both globally unique and stable – no two O2Es should have the same DUID, and an O2E's DUID should not change over time. RFC 3315 defines three ways to construct the DUID. In the O2E, DUID construction is limited to the DUID-EN option, with the vendor's IANA registered private enterprise number followed by a 4-byte serial number assigned by the vendor.

The second mechanism is the registration ID as defined in G.984.3 and TR-156. The registration ID is used in some PON deployments to define the network location in which the ONU is installed, thus allowing ONUs to be swapped or selected from a pool at the time of installation. Registration ID can be used in the same way for O2E identification in O2E-EMA discovery. If the registration ID is configured in an integrated ONU/O2E device, the same configured parameter can be used by the ONU and by the O2E discovery functions.

I.25 Initiation of NETCONF connection and O2E-EMA Authentication

Before the O2E and the EMA can establish a NETCONF connection, they need to authenticate each other's identities. The mutual authentication takes place using X.509 certificates, with each node tracing the other node's certificates to a trust anchor. To validate against a trust anchor, the O2E contains one or more trusted certificates (e.g., pinned certificates, CA root certificates, intermediate certificates, or issuing certificates) that are either pre-loaded in the O2E or provided to the O2E by a secure means outside the scope of this specification.

The EMA and the O2E each contain unique certificates. The EMA's certificate is unique to each EMA Aggregation, and the O2E's certificate is unique to each O2E device. Each node (O2E and EMA) provides the certificates necessary to allow the other node to trace its identity back to the applicable trust anchor.

The IDevID serial number and enterprise identifier form a globally unique value. It is recommended that DUID-EN and IDevID representations of this information be consistent. The DUID-EN enterprise ID and unique identifier must be converted from unsigned values to a printable string for use in the IDevID. For example, for a device in which the DUID-EN contained enterprise ID 0x0DE9 (3561 decimal) and serial number 0x0ABC (2748 decimal), the subject DN would be populated as shown below:
Subject DN="/O=Broadband Forum/C=US/ST=CA/L=Fremont/CN=3561-2748/serialNumber=2748"

RFC 7589 specifies the use of NETCONF over TLS with mutual X.509 authentication. In the FTTEp architecture, the O2E is the server for both NETCONF and TLS and the EMA is the client for both protocols.

However, since the O2E is the node on which power may be cycled, it initiates the TCP connection to the EMA using NETCONF Call Home rather than waiting for the EMA to initiate the connection.

I.26 Discovery Messages

The discovery process uses two message types, both of which are carried within DHCP or DHCPv6 messages. O2E Discover is sent from the O2E to initiate the process. EMA Offer is sent from the DHCP/DHCPv6 server to provide information on one or more EMAs to the O2E. While the discovery process may be based on either v4 or v6 IP message types, the support of IPv6 is mandatory and IPv4 is optional.

The O2E Discover message is sent by the O2E to identify itself and to request the IP address of the EMA with which it should connect. It can be formatted as any of several DHCP or DHCPv6 messages.

The O2E Discover message includes the options shown in Table I-3 and described below.

Table I-3: DHCPv6 and DHCP options used for O2E Discover message

Description	DHCPv6 option			DHCP option (IPv4)		
	#	Name	Ref	#	Name	Ref
DHCP Unit Identifier (DUID)	1	Client Identifier	RFC3315	61	Client Identifier	RFC4361
Requested parameters	6	Option Request	RFC3315	55	Parameter Request List	RFC2132
BBF-specific information	17	Vendor-Specific Information	RFC3315	125	Vendor-Identifying Vendor-Specific Information	RFC3925

The DHCP Unique Identifier (DUID) is mandatory in all O2E Discover messages. Note that in addition to the DUID, the O2E Discover message can include a Registration ID as described below.

The requested parameters option is used in DHCPv6 and DHCP client messages to identify to the DHCP server the network information sought by the client. For O2E Discover, the requested information includes the vendor-specific information option. The O2E may request other information in addition to this option.

The Vendor-specific Information option is used to provide BBF-specific information as identified by the BBF enterprise-number (3561) assigned by IANA. The formatting used for the Vendor-specific Information option for DHCPv6 and DHCP messages is described in TR-301 Appendix A. For O2E Discover, the option is included using the BBF enterprise-number value of 3561 and a SuboptionN-code of 192.

The TLVs used in the SuboptionN-data field for SuboptionN-code = 192 (O2E Discover) are shown in Table I-4. Any Type value not listed in the table is reserved for future use.

Table I-4: TLVs for O2E Discover

Type	Length	Value	Description
00	Variable	Registration ID	ID applied to the ONU for PON registration.

If a registration ID is configured in the O2E, it can be used by the network operator to facilitate mapping the O2E to a EMA. If an O2E is configured with a registration ID, the O2E must include the Registration ID TLV in all DHCPv6 and DHCP O2E Discover messages.

I.27 EMA Offer Message

EMA Offer is sent by a DHCPv6 or DHCP server to the O2E to provide reachability information for the EMA with which the O2E should connect. It can be formatted as DHCPv6 Reply, DHCPv6 Advertise, DHCPOFFER, or DHCPACK, depending on the type of server and the DHCP message type to which it is replying.

One or more EMA Information sub-options are encapsulated within the Vendor-specific Information option (option 17) in DHCPv6 messages and within the Vendor-Identifying Vendor-specific Information option (option 125) in DHCP messages, with the BBF Enterprise-number value of 3561 used to identify the vendor. The formatting used for the options 17 and 125 is described in TR-301 Appendix A. Each instance of EMA Information is identified using the SuboptionN-code of 193.

The TLVs used in the SuboptionN-data field for SuboptionN-code = 193 (EMA Information) are shown in Table I-5. Any Type value not listed in the table is reserved for future use.

Table I-5: TLVs for EMA Information

Type	Length	Value	Description
16	4 octets	IPv4 address	IPv4 address of the EMA being offered
17	16 octets	IPv6 address	IPv6 address of the EMA being offered
18	1 octet	PCP	Priority Code Point value to be used by the O2E for management traffic.
19	Variable	Domain name	The domain name of the EMA being offered.

The TLVs in Table I-5 are described below.

- IPv4 address, IPv6 address and Domain name each provide the reachability information in different forms to allow the O2E to establish a TCP connection with the EMA. Only one of these TLVs is typically provided.
- PCP provides the Priority Code Point value to be used by the O2E for all traffic sent to the EMA

I.28 Discovery process

The EMA discovery process starts when power is first applied to a O2E. The discovery process takes place as follows:

- 1) The O2E generates an IPv6 link-local address on its uplink interface and performs Duplicate Address Detection.
- 2) Using its link-local address as source address, the O2E sends a O2E Discover message formatted as DHCPv6 Information-request.
- 3) The O2E can also send the O2E Discover message formatted as DHCPDISCOVER and/or DHCPv6 Solicit to solicit a routable address and/or to initiate discovery on IPv4 networks. It can also use SLAAC to generate a routable IPv6 address.
- 4) A DHCP or DHCPv6 server maps the DUID and/or registration ID encapsulated in the O2E Discover message to one or more EMAs.
- 5) The DHCP/DHCPv6 server responds with a EMA Offer message containing one EMA Information sub option for each EMA being offered. The EMA Information sub options are listed under the Vendor-Specific Information option in the order in which the O2E should attempt to connect.
- 6) If the EMA Information sub option(s) in the EMA Offer contain Domain names, or if the EMA address(es) are IPv4 or IPv6 routable addresses, the O2E must complete the process of generating a corresponding routable address before proceeding to step 6. However, if the EMA IP address(es) contained in the EMA Offer are IPv6 link-local addresses, the O2E must proceed with step 6 using its own IPv6 link-local address.

- 7) The O2E performs the following steps when establishing a NETCONF connection with a EMA. In the steps below, the EMA is the NETCONF/TLS Client and the O2E is the NETCONF/TLS Server.
 - a) If the current EMA Information sub option contains a Domain name, the O2E performs a DNS lookup to resolve the domain name to an IP address.
 - b) The O2E opens a TCP connection on port 4335 to the offered EMA.
 - c) The EMA opens a TLS connection to the O2E as defined in RFC 7589.
 - d) The O2E and EMA each perform path certificate validation as per RFC 7589 and RFC 5280. The O2E ensures that the presented EMA certificate has a valid chain of trust to a pre-configured trust anchor and derives the EMA's NETCONF username from its certificate. The EMA ensures that the presented O2E certificate has a valid chain of trust to a pre-configured trust anchor and that the O2E's reference identifier matches the identifier pre-configured in the EMA. If either the EMA or the O2E cannot authenticate the other's identity, the connection is terminated.
 - e) After mutual authentication has completed and the TLS connection established, the O2E immediately starts the NETCONF server.
 - f) Once each node has authenticated the other, the EMA and the O2E can begin to exchange NETCONF messages sent as TLS application data, as specified in RFC 7589.
 - g) If the O2E cannot successfully establish a NETCONF connection with the EMA, it closes the TLS and/or TCP connections and attempts to establish a connection with the next offered EMA.

I.29 Management VLAN

All discovery traffic and O2E-EMA traffic uses a predefined management VID in the range from 0 (P-tagged) to 4094 at the O2E interface. If the network uses a different VLAN for management traffic to and from the EMA, it is the responsibility of the higher order node to which the O2E connects to perform tag operations that place the upstream and downstream O2E-EMA traffic on the correct VLANs. In the case of G-PON being used as the O2E backhaul, the mapping of frames to the correct VLAN may take place in the backhaul function of the O2E by command from the higher order node. The EMA Information sub-option within the EMA Offer message contains a PCP field that provides the priority value to be used by the O2E for EMA traffic. The higher order node should perform any VLAN tag manipulations necessary to convert between the management VLAN used by the O2E and the management VLAN used by the network.

I.30 Time management

For the logging of events and alarms, the O2E needs to maintain the local time. This includes time zone and daylight savings time offsets since the EMA and O2E may be in different time zones or daylight savings time regions.

The Network Time Protocol (NTP) is widely used to synchronize computer clocks in the Internet. NTP version 4 (NTPv4) described in RFC 5905, is backwards compatible with NTP version 3 (NTPv3), described in RFC 1305, as well as previous versions of the protocol. NTPv4 includes a modified protocol header to accommodate the Internet Protocol version 6 address family. It includes a dynamic server discovery scheme, so that in many cases, specific server configuration is not required. The O2E must support an NTPv4 client.

I.31 EMA Aggregator

The EMA Aggregator provides an aggregation function between the individual EMAs and the NMS/OSS. This has a number of benefits, namely:

- Reducing the number of management channels that need to be setup, monitored and maintained i.e., 1 per EMA Aggregator rather than 1 per EMA.
- Reducing the number of IP addresses that the NMS needs to be aware of
- Reducing the maintenance burden on the NMS, for example:
 - The EMA Aggregator can manage the scheduling of firmware upgrades across all its associated EMAs

- Only a single copy of the new firmware needs to be downloaded to the EMA Aggregator.

Many of the benefits of the EMA Aggregator stem from it being co-located with its EMAs, but this is not a requirement, and the EMA Aggregator can be in an entirely different physical location.

While the EMA Aggregator and its EMAs can be physically separated, they are indivisible from a functional perspective. The interface between EMA Aggregator and EMA is NOT exposed, and is therefore not a defined point of interoperability. This means that both the EMA Aggregator and the EMA need to come from the same vendor.

While security is an issue for any management system, the EMA Aggregator does not of itself introduce any new security requirements. The whole point of the EMA Aggregator is to increase the management system scalability, but this is implementation dependent and not subject to any quantitative formal requirements.

At the southbound interface, each EMA has a one-to-one relationship with a O2E. Each EMA communicates with its respective O2E via a TCP socket identified by a unique combination of IP address and TCP port number. The EMA/EMA Aggregator architecture may be designed in different ways. In each case below, the O2E communicates with the IP address used by the EMA for southbound communication. The configuration of IP addresses in the EMA Aggregator and the EMAs is out of scope for this specification.

- EMAs may be fully contained within an EMA Aggregator. The EMA Aggregator may be implemented as a standalone device or as a function within a device such as a switch, an OLT, or a network management server. The EMAs communicate with their respective O2Es using a common network interface and are differentiated by the combination of IP address (which may also be the address used by the EMA Aggregator for northbound communication) and TCP port number.
- EMAs may be implemented separately from the EMA Aggregator, which aggregates the northbound traffic to and from the NMS. Each EMA has its own IP address to communicate with its O2E. The EMAs may be implemented in the same device as each other and as the EMA Aggregator, or in different devices that may be distributed in the network.

Appendix II. FTTEp using Gfast technology

II.1 Gfast introduction

Gfast is the Broadband Forum term used to name a copper access technology based on ITU-T G.fast family of Recommendations listed in section II.4.

Gfast brings DSL technology to a level comparable to the FTT grade of service. It allows service providers to offer customers multiple broadband services, of both constant and variable data rates, with total aggregated data rate up to 2 Gbit/s and low propagation delay. Such services include multi-channel HD video, browsing and gaming, high-quality audio and voice or High-Speed Internet Access.

Gfast technology provides an established solution for fiber extension in environments where the service provider experiences difficulties to reach the subscriber with an all fiber approach. Gfast technology is specifically targeting deployments where crosstalk exists between the wires connected to the different customers. This crosstalk, which may be rather high, results from the coupling of signals between twisted pair wires running in the same cable binders for some portion of the way between the O2E and the customer's premises' NTE. Gfast technology employs sophisticated crosstalk cancellation techniques in both the downstream and upstream directions to cancel this crosstalk and bring the performance levels of a specific line to levels that may even exceed single line performance (performance when there is no crosstalk to that line from other lines), due to exploitation of the crosstalk.

Gfast is a technology that has been developed to operate on any kind of twisted pair, regardless of its quality. An example of a typical Gfast deployment is a HSIA in a MDU over Point-to-Point data-grade twisted pair, or a telco-grade twisted pair.

Deployment model SCK-1, addresses a deployment where the O2E installation is done using a modular extendable approach, i.e., multiple O2E boxes are installed, each serving a different set of lines/customers, served from this location. These lines may run (for some portion of the way) in the same cable binders, hence exhibit potentially high crosstalk between them. This "stacked" approach of O2Es may be used for multiple deployment scenarios:

- Gradual, upgradable installation approach by an operator, gradually increasing the number of ports served by the O2E location, by installing more O2E units (boxes) as needed.
- Allowing for several operators to offer broadband services over the same copper infrastructure. Each operator is providing its services using its own O2E(s). In some countries offering this option is a barrier for allowing the local regulator to allow deploying the technology.

In addition, a combination of the above usage scenarios is also possible.

II.1.1 Key application features

The following key application features of Gfast technology are specified in listed in [1]

- Best aspects of fiber to the home (FTTH): up to 2 Gbit/s aggregate net data rate;
- Best aspects of ADSL2: customer self-install and operation in the presence of bridged taps, avoiding operator truck-rolls to the customer premises for installation and activation of the broadband access service;
- Coexistence with ADSL2 and VDSL2 on adjacent wire-pairs;
- Low power operation and all functionality necessary to allow transceivers to be deployed as part of reverse powered (and possibly battery operated) network equipment and to adapt to environmental conditions (e.g., temperature);

- Management capabilities allowing transceivers to operate in a zero-touch deployment, avoiding truck-rolls to the network equipment for installation and activation of new or upgraded broadband access service;
- Control of the upstream vs downstream transmission time to adapt net data rates to the needs of the business and the residential customers;
- Vectoring (self-crosstalk cancellation) for increased net data rates on wire-pairs that experience far-end crosstalk from ITU-T G.9701 transceivers in the same vectored group operating on other wire-pairs in the same cable or operating on other wire-pairs originating from the same network equipment;
- Network timing reference (NTR) and time-of-day (ToD) transport for network frequency and time synchronization between network and customer premises equipment;
- Configuration of spectrum use, including configuration of the transmit power spectral density (PSD) limitations and notches to meet electromagnetic compatibility (EMC) requirements.
- Dynamic time assignment (cDTA) is used to dynamically set and update the sharing of the TDD frame between upstream and downstream, by changing the number of downstream symbol periods (Mds) of the TDD frame during showtime, on all active lines of the vectored group, upon request by the DRA.
- For operation in a crosstalk-free environment, Independent time assignment (iDTA) is defined to dynamically set and update the sharing of the TDD frame between upstream and downstream, by changing the number of downstream symbol periods (Mds) of the TDD frame during showtime upon request by the DRA.

II.1.2 Key functionalities and capabilities

The following key functionalities and capabilities of Gfast technology are specified and listed in [1]:

- Transparent transport of data packets (e.g., Ethernet packets) at an aggregate (sum of upstream and downstream) data rate of up to 2 Gbit/s;
- In-band spectral usage up to 212 MHz;
- Configurable start and stop frequencies, PSD shaping and notching;
- Discrete multitone (DMT) modulation (2 048/4 096 subcarriers with 51.75 kHz subcarrier spacing);
- Time-division duplexing (sharing time between upstream and downstream transmission);
- Low latency retransmission, facilitating impulse noise protection (INP) between the V and T reference points at all data rates to deal with isolated erasure events at the U reference point of at least 10 ms, without loss of user data;
- Forward error correction based on Trellis coding and Reed-Solomon coding;
- Vectoring (self-FEXT cancellation), where this edition of the Recommendation uses linear precoding;
- Discontinuous operation where not all of the time available for data transmission is used;
- Online reconfiguration (OLR) for adaptation to changes of the channel and noise characteristics, including fast rate adaptation (FRA).

II.1.3 Key performance aspects

The following aggregate net data rates over a 0.5 mm straight wire-pair for G.fast 106 MHz profiles are specified in [1]:

- 500 to 1000 Mbit/s on a wire-pair shorter than 100 m;
- 500 Mbit/s at 100 m;
- 200 Mbit/s at 200 m;
- 150 Mbit/s at 250 m;
- 500 Mbit/s at 50 m, while operating in the band above 17 MHz.

In addition to this, TR-380 [5] provides a set of functional, stability and performance test cases and related pass/fail requirements for G.fast implementations according to ITU-T Recommendations G.9700 [2] and G.9701 [1]. The goal of TR-380 is to provide performance requirements between a DPU and one or more

CPEs. The test cases are defined for a DPU and CPE combination. The functional testcases cover that functionality needed to verify the correct operation and reporting required for executing the performance testcases. Technical content in this test plan includes test setup information, equipment configuration requirements, test procedures, and pass/fail requirements for each test case.

Another BBF document, TP-337 [6] provides a set of test cases and framework to verify interoperability between an FTU O (e.g., a DPU) and one or more FTU Rs (e.g., CPEs). The test cases are defined for a Device Under Test (DUT – either a DPU or CPE), tested against a Link Partner (either a CPE or DPU respectively). The DPU/CPE may be a reference design, however containing the necessary FTU O/R and system functionality to execute this test plan (see e.g., section 4.2). TP-337 serves as the test plan, including pass/fail requirements for each test case, for the Broadband Forum Gfast Certification Program. This test plan is also applicable to implementations requiring Reverse Power Feed (RPF) e.g., according to ETSI TS 101 548 1 [7].

II.2 Definitions

The following terminology is used throughout this Appendix.

Gfast Broadband Forum’s name for the gigabit broadband access technology specified by the ITU-T in the recommendations listed in section II.4, together with later additions and amendments

II.3 Abbreviations

This Appendix uses the following abbreviations:

DPU Distribution Point Unit

II.4 References

Document	Title	Source	Year
[1] G.9701	<i>Fast access to subscriber terminals (G.fast) – Physical layer specification</i>	ITU-T	2019
[2] G.9700	<i>Fast access to subscriber terminals (G.fast) – Power spectral density specification</i>	ITU-T	2019
[3] G.997.2	<i>Physical layer management for G.fast transceivers</i>	ITU-T	2019
[4] G.994.1	<i>Handshake procedures for digital subscriber line transceivers</i>	ITU-T	2019
[5] TR-380	<i>Gfast Performance Test Plan</i>	BBF	2020
[6] TP-337	<i>Gfast Certification Test Plan</i>	BBF	2019
[7] TS 101-548-1	<i>European Requirements for Reverse Powering of Remote Access Equipment; Part 1: Twisted pair networks, V2.4.1</i>	ETSI	2020
[8] TPLS.G-HN	<i>Operation of G.hn technology over access and in-premises phone line medium</i>	ITU-T	2015
[9] TR-301 Issue 2 Amendment 1	<i>Architecture and Requirements for Fiber to the Distribution Point</i>	BBF	2020

II.5 Deployment models using Gfast technology

Table II-1 provides an overview of the use cases defined by this document that are covered by this appendix. Future versions of this document may expand this list.

Table II-1: Summary of covered use cases

Category	Use case		Clause
1a-1	Use Case 1a-1 – “Point-to-Point data-grade twisted pair for HSIA in MDU”		II.6
1a-2	Use Case 1a-2 – “Point-to-Point telco-grade twisted pair for HSIA in MDU”		II.7
1a-2	DPU stacking using cross-DPU vectoring		II.8
1a-11	Use Case 1a-11 – “Fiber extension by concatenating copper distribution networks (CDNs)- CuTTB”		Description is for further study
1b-1	Use Case 1b-1 – “Point-to-Point Coaxial cabling with frequency diplexers for HSIA and satellite TV in MDU”		II.10
1b-2	Use Case 1b-2 – “Point-to-Point Coaxial cabling for HSIA in MDU”		II.11
2-1	Use Case 2-1 – “Single port Point-to-Point data-grade twisted pair or coaxial cabling”		II.9
2-2	Use Case 2-2 – “Multiple port Point-to-Point data-grade twisted pair or coaxial cabling”		II.9

II.6 Deployment model 1: Use case 1a-1 Point-to-Point data-grade twisted pair for HSIA in MDU

The mapping of Gfast to the architecture of this use case is shown in Figure II-1.

- Fibre
- Ethernet
- CAT5 or better TP wire

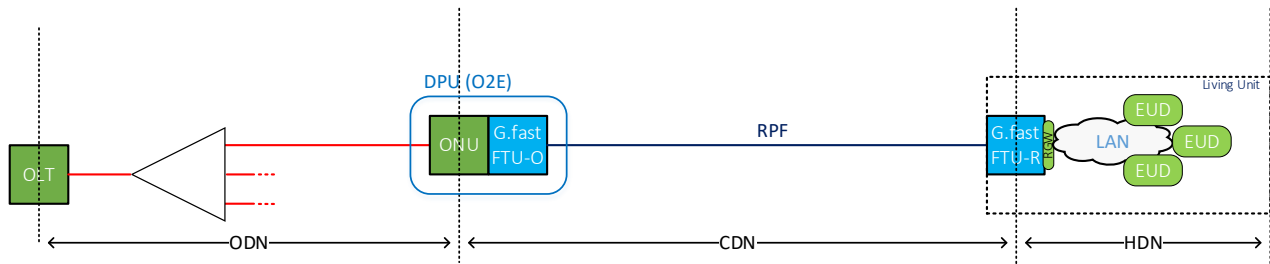

BBF_26

Figure II-1: P2P data-grade twisted pair for HSIA in MDU - Generalized Use Case 1a-1

This deployment model focuses on the architecture and structure of the O2Es. "Southbound" from the distribution point (DP) towards the customer's premises, i.e., the CDN and HDN, the details laid out in many of the other use cases in this document may apply (those talking about the twisted pair infrastructure). In this deployment model, the ODN feeds a O2E element that converts the optical signal into electrical signals and feeds them through a copper infrastructure to the customers. A single O2E installed in the FTTEp location may have typically 1 to few tens of ports.

When using Gfast technology, the O2E is referred to as a Gfast DPU per TR-301 [1] that is composed of:

- An Optical Network Unit (ONU) that terminates a leaf of an ODN and provides a User Network Interface (UNI) to a Gfast port on a DPU, and
- An ITU-T G.fast FTU-O transceiver

The Gfast port of the DPU (O2E) is connected through a twisted pair line to a G.fast transceiver at the customer's premises that is termed ITU-T G.fast FTU-R.

In this single line scenario, no vectoring is used.

The Gfast DPU may be reverse powered (RPF).

II.7 Deployment model 2: Use case 1a-2 Point-to-Point telco-grade twisted pair for HSIA in MDU

This deployment model builds on deployment model 1 by extending the number of lines and introducing the telco grade wiring.

The mapping of Gfast to the architecture of this use case is shown in Figure II-2.

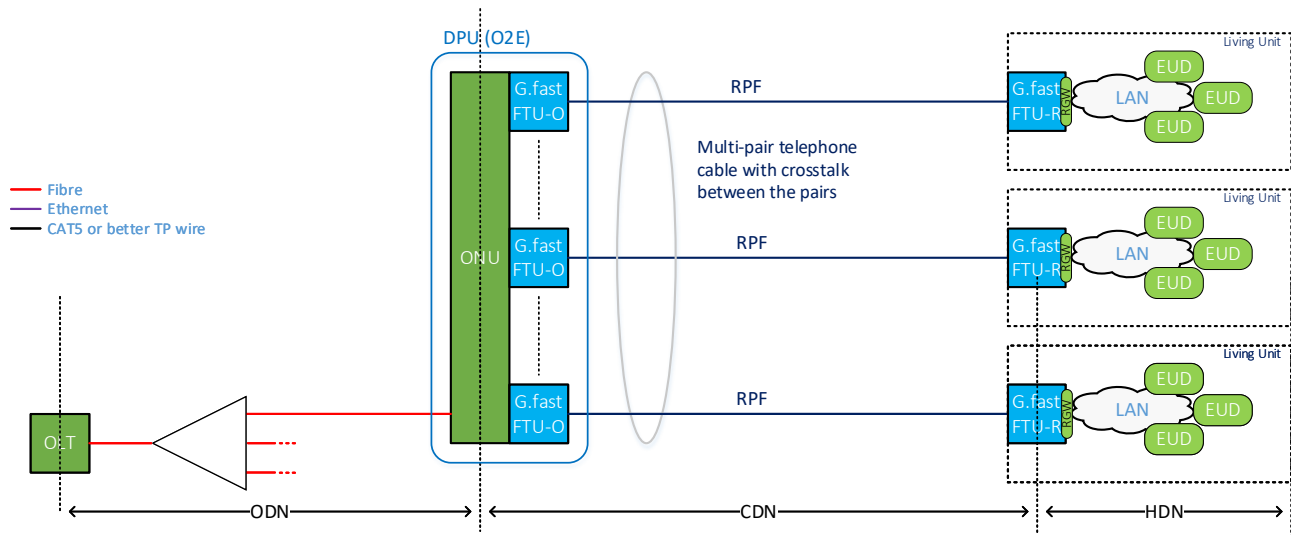

Figure II-2: P2P telco-grade twisted pair for HSIA in MDU - Generalized Use Case 1a-2

A single O2E (i.e., Gfast DPU) installed in the FTTEp location may have typically a higher number of ports, connected to multiple twisted telco-grade wire pairs.

In this deployment model, the wires running from the OE (i.e., a distribution point (DP)) are exhibiting substantial crosstalk between them. It is therefore required to configure the O2Es in the DP location in a way that will enable to use the crosstalk cancellation technique of G.fast, i.e., vectoring. That Gfast vectoring is an effective technology of choice to handle crosstalk is a well-known fact, as it maximizes the data throughput of all connected customers all of the time.

Ownership of the access infrastructure depends on the region and location of the access wiring: outside wirings may be owned by an infrastructure provider, which may or may not be linked in some way to the service provider, while in-building wiring may be owned by the building owner). In-home wiring are usually owned by the premises owner.

The Gfast DPU (O2E) may be reverse powered (RPF).

II.8 Deployment model 3: DPU stacking using cross-DPU vectoring

Figure II-3 shows the mapping of deployment model 3 to the Gfast technology (the figure shows stacking of two ITU-T Gfast O2Es as an example. There may be more than two O2Es installed in the DP location):

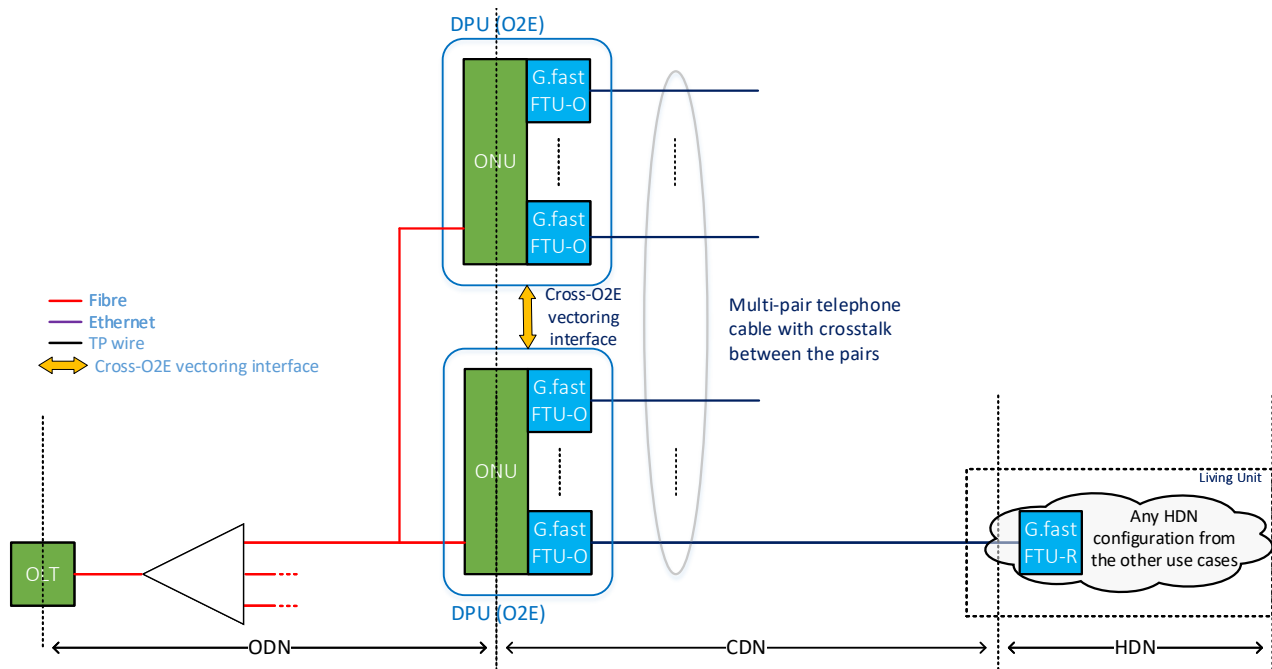

Figure II-3: Mapping of deployment model 3 to Gfast technology

Note that deployment model 3 is an implementation of use case 1a-2 where stacking of O2Es is needed. In this deployment model, the ODN feeds multiple O2E elements (two or more) installed in the FTTEp location that each may have typically few tens of ports.

Different Gfast DPUs (O2Es) are cross-connected to each other via a cross-O2E vectoring (crosstalk cancellation) interface. This facilitates cancelling the crosstalk between lines connected to different O2Es, using appropriate processing within the units.

The focus of this model is on the structure of the O2E and not on the structure of the network within the customer's premises. Therefore, coexistence of services is not relevant for this use case

II.8.1 Deployment configuration

In the discussed deployment model, the wires running from the DP location are exhibiting substantial crosstalk between them. It is therefore required to configure the stacked-O2Es in the DP location in a way that will enable to use the crosstalk mitigation technique of Gfast, i.e., vectoring. This is achieved by:

- Interconnecting the multiple O2Es using the cross-O2E vectoring interfaces
- Configuring the multiple O2Es to allow crosstalk cancellation, in a way in which all the lines belong to the same vectoring group, using the management tools provided, as further explained in the next section.
- Activating the cross-O2E vectoring engines within the O2Es to cancel the crosstalk between the lines outgoing from the multiple O2Es.

II.8.2 Deployment management

In the discussed deployment model, the following OAM functionalities are required by the service provider.

- Provisioning
- Monitoring and diagnosis
- Proactive Network Maintenance (PNM)

Every O2E in this stacked deployment is managed separately by either a single operator or by different operators. However, some configuration parameters need to be coordinate between O2Es. For example, some parameters will need to be configured to the same values to allow the cross-O2E vectoring to work. It should be noted that this is not much different than the coordination needed in configuring the different lines within a specific O2E.

II.9 Deployment model 4: Use case 2-1/2-2 Single port/Multiport Point-to-Point data-grade twisted pair or coaxial cabling

This deployment model focuses on the architecture and structure of the point-to-point topology for delivering broadband services to residential users (SFU or MDU) by preferable reuse of existing wiring infrastructure, twisted pairs or coaxial cables.

The mapping of Gfast to the architecture of this use case is shown in Figure II-4.

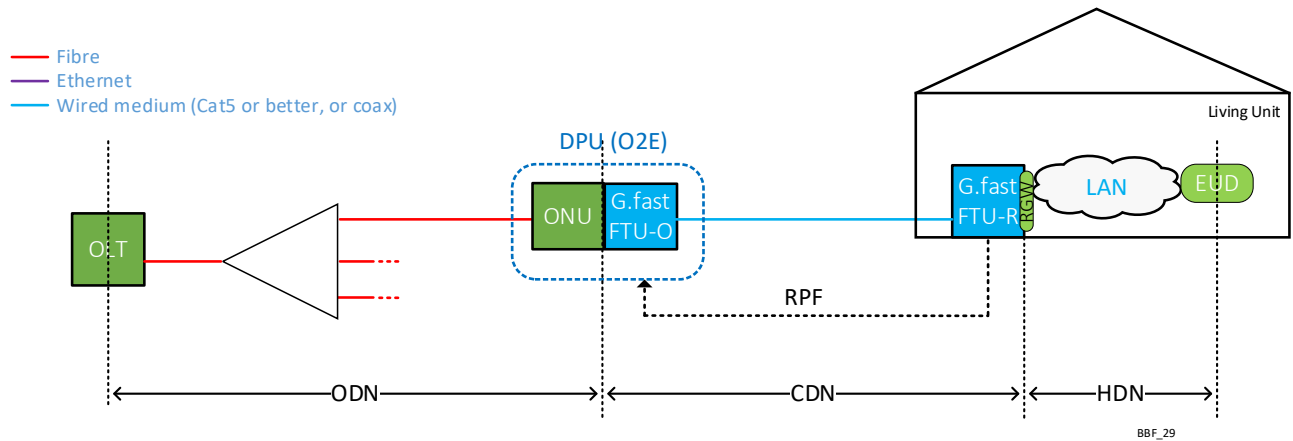

Figure II-4: Mapping of use case 2-1 to Gfast technology

The single port converter O2E, e.g., Gfast DPU per TR-301 [1], is located at a short distance (some 200m) to the point-of-entry for the premises (in a Network Interface Device (NID) or just inside the living unit), allowing

peak rates over the copper wire. For increased data rates on wire pairs physically located close to each other (i.e., in the use case 2-2 Multiport Point-to-Point data-grade twisted pair or coaxial) that experience some crosstalk, use of vectoring technique (self-crosstalk cancellation) for interference mitigation is provided for each user.

Depending on the medium used, several services can coexist on the line; POTS in case of twisted pair or MoCA in case of coaxial cable. Since ITU-T G.fast and ITU-T G.hn use the same spectrum, due to high self-crosstalk particularly at higher frequencies, use of these technologies in the same access environment should be avoided [8].

II.10 Deployment model 5: Use case 1b-1 Point-to-Point Coaxial cabling with frequency diplexers for HSIA and satellite TV in MDU

This deployment model focuses on the architecture and structure of the point-to-point topology for delivering HSIA in a lower frequency band and satellite TV signal in a higher frequency band.

A diplexer merges the Gfast and SATV signals over the coaxial cable. In each residential user (living unit in MDU) a second diplexer splits the Gfast and SATV signal.

The mapping of Gfast to the architecture of this use case is shown in Figure II-5.

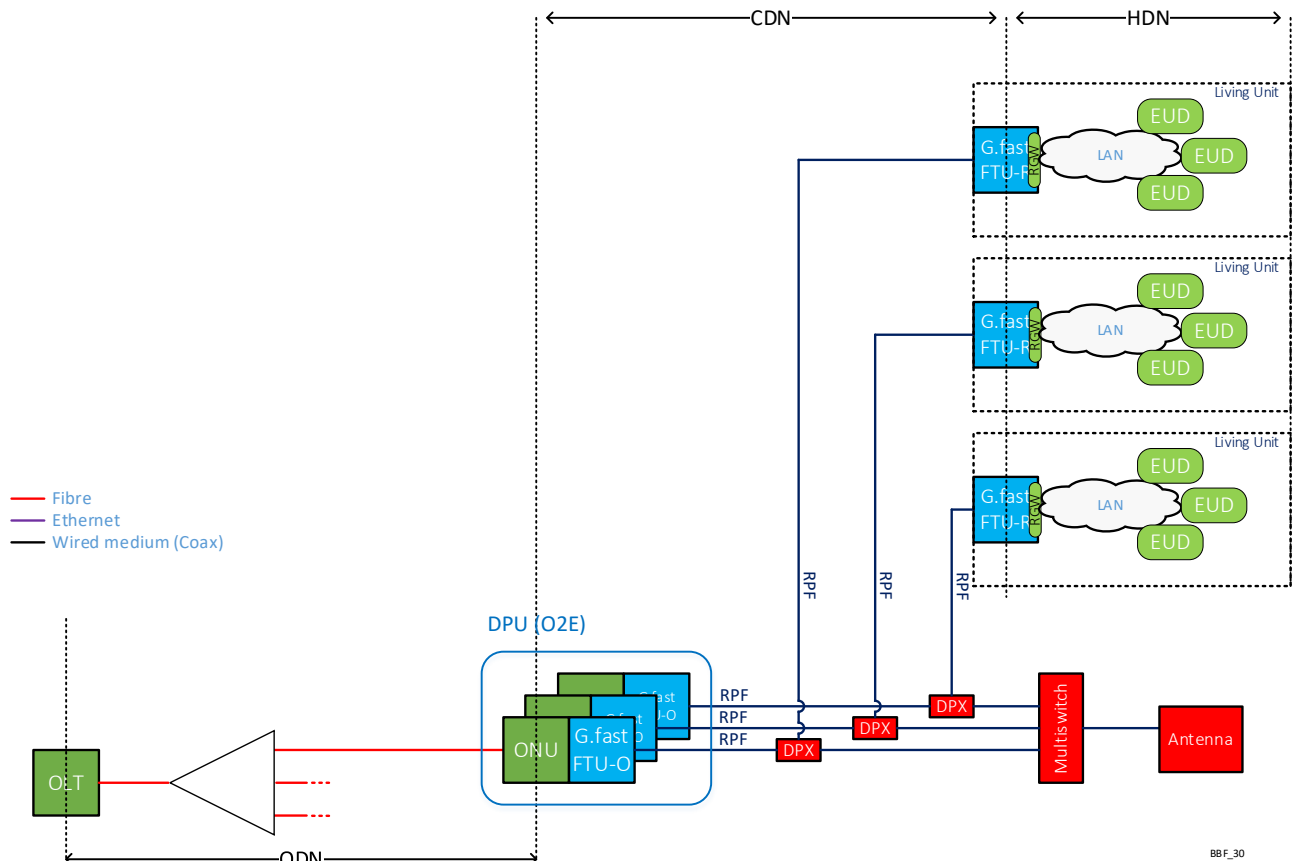

Figure II-5: Mapping of use case 1b-1 to Gfast technology

In case the diplexers (DPXs) are RPF capable, the Gfast DPU (O2E) may be reverse powered (RPF).

II.11 Deployment model 5: Use case 1b-2 Point-to-Point Coaxial cabling for HSIA in MDU

This deployment model is similar to the previous one (1b-1) and it focuses on the architecture and structure of the point-to-point topology for delivering High Speed Internet Access (HSIA) over coaxial cable to each residential user (living unit in a MDU).

The mapping of Gfast to the architecture of this use case is shown in Figure II-6.

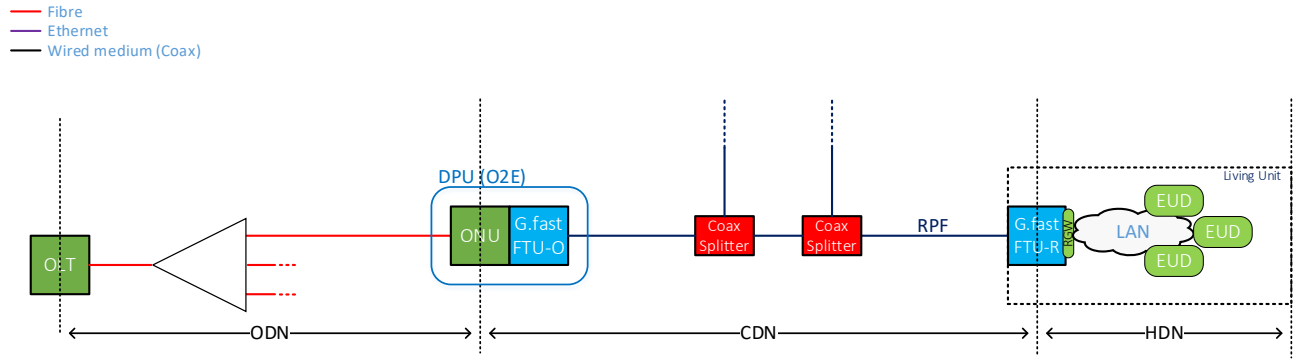

Figure II-6: Mapping of use case 1b-2 to Gfast technology

The Gfast DPU (O2E) serves multiple living units in a MDU with the O2E located in an equipment room or a cabinet near the MDU. G-PON or XG-PON/XGS-PON fiber connects the O2E to the network. Each Gfast DPU (O2E) serves one customer, having one NTE/RGW connected to the line. Service installation may require a technician visit to the living unit. The coaxial cable to and within living unit can be up to 200 meters. The wiring may connect to many wall jacks in the home. Wi-Fi, Ethernet or other LAN in the premises connects multiple EUDs to the RGW.

Appendix III. FTTEp using G.hn Access technology

III.1 G.hn Access introduction

G.hn Access is the term used to name a copper access technology based on ITU-T G.hn family of Recommendations.

NOTE - Devices certified by HomeGrid Forum for its G.hn Access certification profiles are named GiGAWIRE™ devices.

G.hn is defined to operate over any physical networking medium, such as coaxial cable, telephone/CATx wires, powerline and over plastic optical fiber.

While the original application focus for G.hn was solving home-networking challenges over any type of wiring available in residential environments (typically power lines, coaxial cables and twisted pairs), the industry identified G.hn as a solution for broadband access applications, especially in installations that had legacy twisted pair cabling for phone service, and where installing new optical fiber was prohibitively expensive.

The use of G.hn systems for broadband access applications like FTTEp is called G.hn Access.

The main characteristics of G.hn Access technology are summarized in Table III-1:

Table III-1: G.hn Access characteristics summary

Area	Sub-area	Coaxial Cable	Twisted Pair
Physical Layer	Line code	DMT (Discrete Multi-Tone)	
	Maximum modulation	5-200 MHz	5-200 MHz
	Tone spacing	195.3 kHz	48.8 kHz
	MIMO support	NO	YES
	Forward Error Correction	LDPC (Low Density Parity Check)	
	PHY layer max rate⁽¹⁾	2000 Mbit/s	4000 Mbp/s
Data Link Layer	MAC layer max rate⁽¹⁾	1700 Mbit/s	3400 Mbit/s
	Automatic Retransmission (ARQ)	Yes	
	Medium Access	TDMA, coordinated by a Domain Master (DM)/CSMA	
	Encryption	AES-128	
	Quality of Service (QoS)	8 levels	

(1) Assuming the maximum options specified by the standard

In the context of FTTEp, G.hn Access provides a solution for fiber extension in environments where the service provider experiences difficulties to reach the subscriber with an all fiber approach (permissions from building owners, local regulations, etc.).

This approach is specifically indicated in deployments where:

- No crosstalk or moderate crosstalk is expected.
- Environments with a high number of lines in a bundle (up to several hundreds). The use of centralized crosstalk mitigation techniques facilitates the scalability of the solution to hundreds of lines.
- Environments that coexistence between service providers is expected. The flexibility of G.hn Access allows to share the existing infrastructure even in environments where crosstalk between subscribers from different service providers is expected.
- Environment where a “pay-as-you-grow” approach makes sense. Additional lines can be easily installed when new customers contract a service. Infrastructure shall not be prepared anticipating future deployments.

III.2 Definitions

The following terminology is used throughout this Appendix.

Device	Any type of system used for an application using a networking transceiver.
End Point	G.hn End Point (EP) as defined in G.9960 Reference Model
G.hn device	A device using a G.996x transceiver.
G.hn domain	A G.996x network comprised of a domain master and its registered nodes.
G.hn network	A group of interconnected G.hn domains
Domain Master	Node in the network (located in the μ DPU) that schedules the transmission in the G.hn Access network and provides management and data interface towards the backbone.
GAM	G.hn Aggregation Multiplexer. It represents the device that implements DM and GDM functionalities as defined in G.9960 architecture. The GAM usually includes an additional switching function to connect it to a broadband backbone.
GAM manager	Entity that implements the Global Master functionality of a G.hn Network as defined in G.9962
GiGAWIRE™	HomeGrid Forum’s name for devices that have been certified for a G.hn Access profile.
GNT	G.hn Network Termination. It represents the device that implements EP functionalities as defined in G.9960 architecture
μDPU	O2E that includes one ONT and GAM
Node	A network element or member

III.3 Abbreviations

This Appendix uses the following abbreviations:

EP	End Point
DM	Domain Master
GAM	G.hn Aggregation Multiplexer
GM	Global Master
GNT	G.hn Network Termination
LCMP	Layer 2 Configuration and Management Protocol
MIMO	Multiple Input- Multiple output
OFB	Operating Frequency Band
PSD	Power Spectral Density
SFP	Form-factor pluggable
SNMP	Simple Network Management Protocol
YANG	Yet Another Next Generation

III.4 References

Document	Title	Source	Year
[1] G.9960	<i>Unified high-speed wireline-based home networking transceivers – System architecture and physical layer specification.</i>	ITU-T	2018
[2] G.9961	<i>Unified high-speed wireline-based home networking transceivers - Data link layer specification</i>	ITU-T	2018
[3] G.9962	<i>Unified high-speed wire-line based home networking transceivers - Management specification</i>	ITU-T	2018
[4] G.9963	<i>Unified high-speed wireline-based home networking</i>	ITU-T	2018

		<i>transceivers – Multiple input/multiple output specification</i>		
[5]	G.9964	<i>Unified high-speed wireline-based home networking transceivers – Power spectral density specification</i>	ITU-T	2016
[6]	TP- TPLS.G-HN	<i>Operation of G.hn technology over access and in-premises phone line medium</i>	ITU-T	2015
[7]	TS 101-548-1	<i>Access, Terminals, Transmission and Multiplexing (ATTM); European Requirements for Reverse Powering of Remote Access Equipment; Part 1: Twisted Pair Networks (v2.4.1)</i>	ETSI	2020
[8]	TR-374	<i>YANG modules for management of G.hn systems</i>	BBF	2018
[9]	TR-069	<i>CPE WAN Management Protocol</i>	BBF	2018
[10]	TR-369	<i>User Services Platform (USP)</i>	BBF	2018
[11]	IEEE 802.3	<i>IEEE 802.3-2018 - IEEE Standard for Ethernet</i>	IEEE	2018

III.5 Deployment models using G.hn Access

Table III-2 provides an overview of the use cases defined by this document that are covered by this annex. Future versions of this document may expand this list.

Table III-2: Summary of covered use cases

Category	Use case	Clause
1a-1	Use Case 1a-1 – “Point-to-Point data-grade twisted pair for HSIA in MDU”	Description is for further study
1a-2	Use Case 1a-2 – “Point-to-Point telco-grade twisted pair for HSIA in MDU”	Description is for further study
1a-6	Use Case 1a-6 – “Multiple Point-to-Multipoint (M-P2MP) over existing indoor phone wiring”	Description is for further study
1a-11	Use Case 1a-11 – “Fiber extension by concatenating copper distribution networks (CDNs)- CuTTB”	Description is for further study
2-1	Use Case 2-1 – “Single port Point-to-Point data-grade twisted pair or coaxial cabling”	III.5.1
2-2	Use Case 2-2 – “Multiple port Point-to-Point data-grade twisted pair or coaxial cabling”	III.5.1

III.5.1 Deployment model 1: Use case 2-1/2-2 Single port/Multiport Point-to-Point data-grade twisted pair or coaxial cabling

III.5.1.1 Introduction

This deployment model is oriented to extending fiber in SFU environments for houses where crosstalk between lines may exist (when several SFUs are served in the vicinity) and where the main objective:

- To reduce installation costs by reusing existing infrastructure:
 - Avoids cost of deploying 50-100m of fiber (no drilling holes or digging front yards)
- Simplicity of installation & maintenance
 - Use of a plug-and-play technology easily integrated in the overall network and with low maintenance

- Scalable solution. Address a house-by-house installation (pay as you grow model) with committing resources upfront.
- To provide a simple and scalable solution for dealing with any possible degradation of service in presence of crosstalk between lines.

Use cases 2-1 and 2-2 are addressed in similar way by G.hn Access technology. The main difference resides in the presence of a cloud crosstalk avoidance algorithm that controls the access to transmission resources in use case 2-2 and that is not needed in use case 2-1.

III.5.1.2 Architectural and Topological Aspects

Figure III-1 shows an example of mapping of this deployment model to G.hn Access technology:

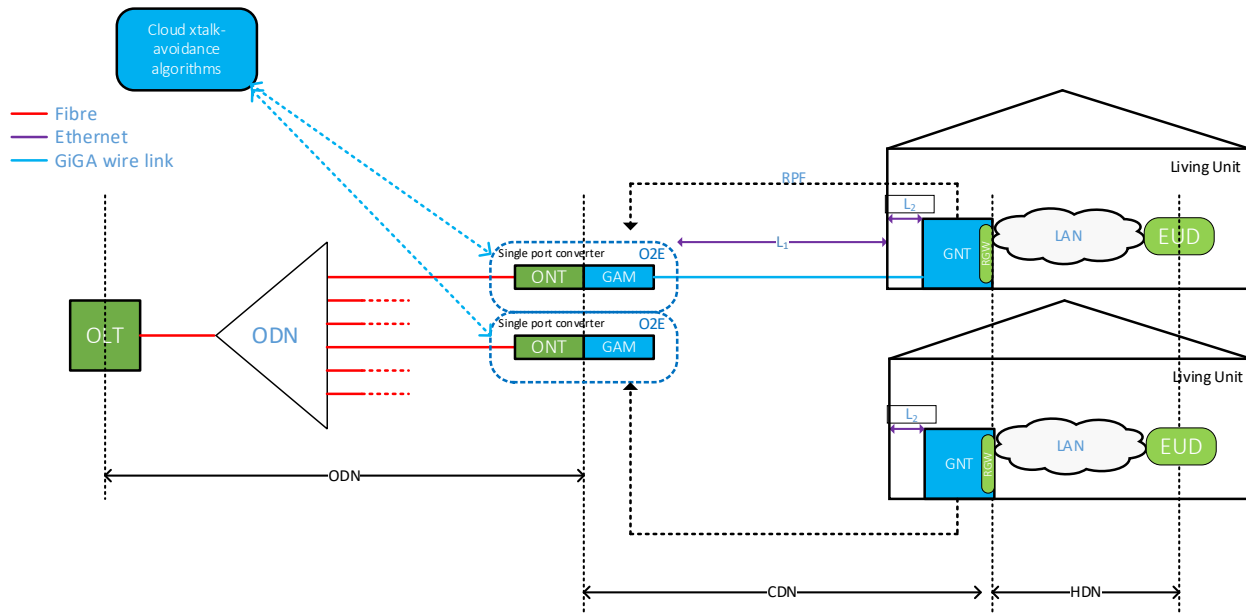

Figure III-1: Mapping to G.hn Access of deployment model 1

In this mapping, the ODN feeds an OE2 element that converts the optical signal into electrical signal in a one-to-one relationship. When using G.hn Access, this element is called a μ DPU and is composed of:

- An ONT
- A GAM element (G.hn Aggregation Multiplexer) with a single output that acts as DM (Domain Master) of a domain composed of 2 nodes (GAM and GNT). The A-interface (see clause 5.2.1 of [ITU-T G.9960]) is connected to the ONT

The southbound port of the μ DPU is connected through coaxial or phone lines to the GNTs (G.hn Network Termination), also called EPs (end point) that may be included in the RGW or connected to it through an Ethernet cable.

Multiple μ DPUs (O2E) can be co-located in the same physical device or located in close vicinity. In this scenario, interference between lines may occur in phoneline deployments. To cope with this situation, a local or cloud-based crosstalk avoidance mechanism may be operated by the service provider to control the access to the shared resources in the copper segment.

If the different SFUs are physically separated, and the crosstalk is limited then no crosstalk mitigation technique is needed.

The use of independent (non-vectored) P2P links allows a “pay-as-you-grow” model where additional lines can be easily installed when new customers contract the service. This is particularly relevant when the P2P G.hn Access link is connected through SFPs modules to the μ DPU.

The μ DPU(s) including the GAM(s) and ONT(s) may be fed through reverse power feeding by each of the individual lines.

III.5.1.3 Location

In this deployment model,

- The GNT may be located indoor or just near the premises.
- The GAM is normally located outside the home, mainly in the front yard or a cabinet. Due to their close proximity to the customer premises, μ DPUs are often deployed in environmentally challenging locations such as pole mounts, outside building wall mounts, and underground chambers. Therefore, temperature and humidity extremes as well as physical security need to be considered in μ DPU implementations.

In some deployments both GNT and GAM may be located within the home. This fiber extension installation allows the service provider to place the ONT/GAM in the most convenient location for him and the GNT in the user preferred location (normally the living room), both equipments being connected through copper infrastructure.

III.5.1.4 Distance

The following table gives typical values of distances for this deployment model. Note however, that they not represent a requirement and other values may be used (with a possible impact on the performance).

Table III-3: Typical distance values

Distance	Distance description	Typical Value (m)	Maximum recommended value (m)
L ₁ ⁽¹⁾	Distance between the O2E and the home	50-100	200
L ₂	Indoor distribution cabling	10-15	30
Note 1: L1 distance may be zero in case the GAM and GNT are both inside the home as mentioned in clause III.5.1.3			

III.5.1.5 Physical interfaces

III.5.1.5.1 Northbound

In this deployment model, the O2E has a fiber backhaul with a minimum bandwidth of 1 Gbps in both the upstream and downstream directions (e.g., G-PON interfaces, P2P fiber may also be used).

III.5.1.5.2 Southbound

Southbound interface (GAM to GNT) offers three possible options:

- Coaxial cable (75Ω)
- One pair of phone line (or Category 5 or better)
- Two pairs of phone line. The use of MIMO techniques in G.hn Access allow 2 phone line wires together in the southbound interface to increase the range or the throughput of this interface
-

Since G.hn Access can handle multi-medium deployments, the service provider does not rely on a single medium for its deployment model, being able to choose the most appropriate medium in each situation with similar hardware. When using SFP connectors in the μ DPU, the installer needs only to plug the right element in the μ DPU without additional configuration.

Installer may decide at the moment of installation what is the most appropriate interface for this specific installation.

The southbound interface offers speeds up to 1 Gbps to match the backhaul interface.

III.5.1.6 Synchronization

The different domains that compose a coordinated G.hn Access network are synchronized by using an external common clock reference. For this, each of the GAMs is synchronized to the same external source generated by one of them as shown in Figure III-2 (see clause 8.6.3 of [[2]]).

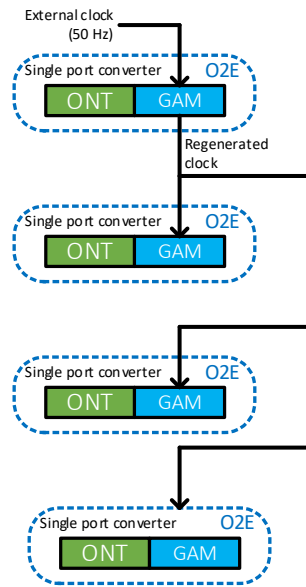

Figure III-2: Synchronization of GAMs in a mP2P scenario

This scheme for synchronization allows scalability in a pay-as-you grow approach. Adding a new GAM necessitates only to connect it to the synchronization clock.

When the GAMs are physically separated, timing synchronization can also be achieved by using IEEE 1588v2.

In order to guarantee that every DM chooses the same MAC Cycle Start time, the parameter NUM_SYNC_PERIODS of the DM is fixed to 1 and EXT_SYNC_ACCURACY of the DM is fixed to 2 μ s. The MAC cycle length is flexible within the boundaries specified by G.996x Recommendations (see CYCLE_MIN and CYCLE_MAX parameters in clause 8.4 of [ITU-T G.9961]), but a value of 40 ms is typically used.

NOTE – This 40 ms value is convenient since many of G.996x systems typically use a MAC cycle linked to the AC power line frequency (50 Hz or 60 Hz). The value of 40 ms for the MAC cycle corresponds to an AC power line frequency of 50 Hz

III.5.1.7 Crosstalk management

The use of elastic capacity deals with crosstalk in broadband access networks based on G.hn Access operating over twisted pair. This approach facilitates the scalability since the complexity of the solution does not grow with the number of users. That means that the same software engine can be reused independently of the number of users.

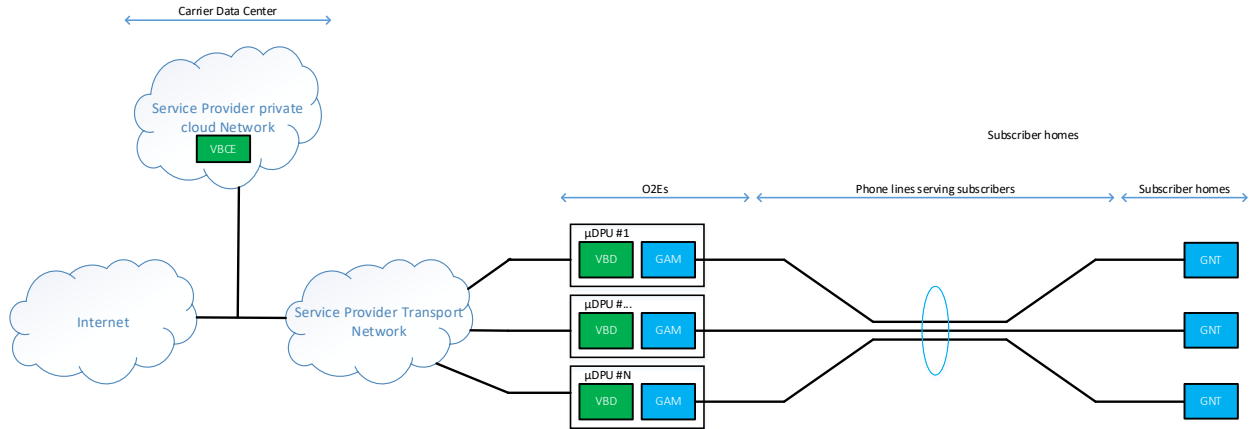

Figure III-3: Use of elastic capacity in deployment model 1

The architecture includes the following elements:

- There are N different μDPUs, each one with up to one subscriber served.
- Each one of the μDPUs is running a software entity called Driver (VBD), which is responsible for collecting crosstalk and traffic information from the southbound interface.
- There is an entity called the VBCE, (also called GAM manager or Global Master (GM), which typically runs in a cloud server (but may also be locally supported), and which communicates with each one of the VBDs.
- There is a distributed protocol running between the VBCE and the VBD that takes care of achieving time synchronization and time slot alignment. VBCE will periodically (every few minutes) send commands to the different VBDs to start crosstalk measurements to build a complete matrix of all crosstalk coefficients between all lines in the system.
- Periodically (every 500ms or so), each VBD collects real-time traffic information from its line (in both directions) and sends a traffic update to the VBCE. The VBCE, after collecting the traffic updates from all VBDs, and taking into account the crosstalk coefficients, computes the optimal allocation of power, spectrum and time slots to ensure that capacity across all lines matches the traffic demands measured by the system.
- After the VBCE computes the optimal power/spectrum/time allocation it sends a message to all VBDs to implement it. The VBDs, in a synchronized way, implement the changes.

The elastic capacity protocol runs usually in the cloud and is therefore easily updated and tuned to the specific needs of a particular installation.

In addition to this protocol, in order to avoid wrong detection of frames, the G.hn Access network makes use of the orthogonal preamble technique to generate the preambles of the frames, as described in [ITU-T G.9960]. The objective is that the frames from other domains that are interfering a given G.hn Access domain are not decoded and are treated as noise.

To achieve this, each G.hn Access domain of a uses a different orthogonal preamble. Nodes of a domain will only decode the frames with the preamble corresponding to its domain. In order to generate the preamble signal, the DM shall program a domain-specific seed taken from the pool of allowed initialization seed values for preambles for the chosen DomainID assigned to that domain (DOD) (see clause 7.2.2.3 of [ITU-T G.9961]).

The GAM Manager/VBCE of the G.hn Access Network guarantees that the seeds used in the Coordinated Network generate preambles that are orthogonal to each other.

III.5.1.8 Coexisting services

Depending on the medium used for the southbound interface of the μDPU, several services may coexist on the line:

- **Coaxial cabling:**
 - MoCA transmissions when MoCA is used as a home distribution service. In this case, MoCA operates at higher frequencies than G.hn Access.
 - G.hn in-home service operating over coaxial cable at the same time as G.hn Access. In this case, both systems will have to share the spectrum. Both domains (in-home application and G.hn Access application) will use the same spectrum (2-200) but the DMs of the two domains will implement time division to access the shared resource.
- **Phone line:**
 - POTS service. G.hn Access will operate however at a higher frequency (3-200 MHz) than POTS service and therefore no interference is expected.
 - G.hn in-home service operating over phone line cabling at the same time as G.hn Access. In this case, both systems will have to share the spectrum. Both domains (in-home application and G.hn Access application) will use the same spectrum (2-200) but the DMs of the two domains will implement time division to access the shared resource.

In addition, G.hn Access system shall not interfere with FM, amateur radio bands and safety of life frequencies. For this, G.hn Access shall notch these bands to avoid interference (phone) or collision (coaxial).

Notches (see clause 8.8.5.5 of [[2]]) may be programmed by the GAM to apply a domain-wide or per-node mask to every node of the domain.

The PSD used for the southbound transmission shall comply with the requirements of clause 6.3.2 of [[5]], injecting a PSD limited to -76dBm/Hz.

III.5.1.9 Performance aspects

G.hn Access technology used as a fiber extender in this deployment model shall provide at least a minimum performance of 1 Gbit/s per line at Ethernet layer over coaxial/phoneline cable in both the upstream and downstream directions.

To achieve these performances, a minimum of an OFB (Operating Frequency Band) of 100 MHz is needed. The following table shows the suitable OFBs for this deployment model.

Table III-4: Recommended OFBs for this deployment model

Medium	OFB	Operating band
Phone line	100 MHz-PB SISO / 100 MHz-PB MIMO	2-100 MHz
	200 MHz-PB	2-200 MHz
	K-OFB (Note 1)	Flexible
Coaxial	100 MHz-PB	2-100 MHz
	200 MHz-PB	2-200 MHz
	K-OFB (Note 1)	Flexible

Note: K-OFB was approved in ITU-T in February 2020. It will provide higher throughputs (up to 10 Gbps on coaxial and 5 Gbps on phone lines) and RF capabilities.

III.5.1.10 Powering (and reverse powering) aspects

In this deployment model, G.hn Access supports:

- Local powering of the μDPU
- Reverse Power Feeding using [ETSI TS 101 548-1] over phone lines (adapted to coaxial lines)
- Remote Powering by using the mechanisms described in Power over Ethernet (see [11])

When using b) or c), each GNT feeds the μDPU including its corresponding GAM.

III.5.1.11 Customer premise equipment

Customer self-install of the CPE is a must in this kind of deployment models.

The CPE may include a GNT and a RGW or it may include only the GNT and connect to the RGW through a direct P2P ethernet cable.

III.5.1.12 Traffic management and QoS

G.hn Access includes an 8-level priority mechanism (see Appendix III of ITU-T G.9960 [1]). O2E GAMs shall implement a mechanism of traffic prioritization based on

- IEEE 802.1p
- DSCP
- User defined rules

III.5.1.13 Multicast

O2Es support both IGMP v1, v2, v3 and MLD v1,v2 functionality based on RFC 4604.

III.5.1.14 Installation

The installation can follow a “pay as you grow” model or “pay upfront” model:

- **Pay as you grow.** This is the most usual model for this deployment model. Each time a new customer is served, a new μ DPU device is installed.
- **Pay upfront.** Whenever an installer installs a μ DPU for the first user, it installs additional μ DPUs for possible new users. Since equipment in this deployment model serve only one user, this model is not really used.

The installation is usually done:

- In self-install mode for the equipment inside the home (GNT) since no additional installation is needed.
- By an installer for the equipment outside the home (μ DPU)

Thanks to the self-install capability in the user equipment, the service provider can schedule the installation of the μ DPU without constraints imposed by the customer and send the GNT to the user by mail service.

III.5.1.15 OAM/ Network management

The use of G.hn Access allows two types of management architectures:

- The use of standardized YANG models via BBF TR-374 [8]. The Yang model allows to manage both sides of the communication link through NETCONF.
- The use of SNMP access to the GAM element and embedded management messages to the GNT. In this case, the GNT may be also managed through TR-069 [9] and TR-369 ([10]).

In addition, both GAM and GNT are accessible through the LCMP protocol described in ITU-T G.9962 ([3])

III.5.1.16 Security

When a GAM/GNT network is set up in secure mode, an AES-128 encryption key is generated after authentication of the nodes to secure the physical layer connectivity.

III.5.1.17 Diagnostics

G.hn Access can be diagnosed using any of the diagnosis capabilities and data models provided by G.hn.

End of Broadband Forum Technical Report TR-419