

TR-385

ITU-T PON YANG Modules

Issue: 2
Issue Date: October 2020

Notice

The Broadband Forum is a non-profit corporation organized to create guidelines for broadband network system development and deployment. This Technical Report has been approved by members of the Forum. This Technical Report is subject to change. This Technical Report is owned and copyrighted by the Broadband Forum, and all rights are reserved. Portions of this Technical Report may be owned and/or copyrighted by Broadband Forum members.

Intellectual Property

Recipients of this Technical Report are requested to submit, with their comments, notification of any relevant patent claims or other intellectual property rights of which they may be aware that might be infringed by any implementation of this Technical Report, or use of any software code normatively referenced in this Technical Report, and to provide supporting documentation.

Terms of Use

1. License

Broadband Forum hereby grants you the right, without charge, on a perpetual, non-exclusive and worldwide basis, to utilize the Technical Report for the purpose of developing, making, having made, using, marketing, importing, offering to sell or license, and selling or licensing, and to otherwise distribute, products complying with the Technical Report, in all cases subject to the conditions set forth in this notice and any relevant patent and other intellectual property rights of third parties (which may include members of Broadband Forum). This license grant does not include the right to sublicense, modify or create derivative works based upon the Technical Report except to the extent this Technical Report includes text implementable in computer code, in which case your right under this License to create and modify derivative works is limited to modifying and creating derivative works of such code. For the avoidance of doubt, except as qualified by the preceding sentence, products implementing this Technical Report are not deemed to be derivative works of the Technical Report.

2. NO WARRANTIES

THIS TECHNICAL REPORT IS BEING OFFERED WITHOUT ANY WARRANTY WHATSOEVER, AND IN PARTICULAR, ANY WARRANTY OF NONINFRINGEMENT AND ANY IMPLIED WARRANTIES ARE EXPRESSLY DISCLAIMED. ANY USE OF THIS TECHNICAL REPORT SHALL BE MADE ENTIRELY AT THE USER'S OR IMPLEMENTER'S OWN RISK, AND NEITHER THE BROADBAND FORUM, NOR ANY OF ITS MEMBERS OR SUBMITTERS, SHALL HAVE ANY LIABILITY WHATSOEVER TO ANY USER, IMPLEMENTER, OR THIRD PARTY FOR ANY DAMAGES OF ANY NATURE WHATSOEVER, DIRECTLY OR INDIRECTLY, ARISING FROM THE USE OF THIS TECHNICAL REPORT, INCLUDING BUT NOT LIMITED TO, ANY CONSEQUENTIAL, SPECIAL, PUNITIVE, INCIDENTAL, AND INDIRECT DAMAGES.

3. THIRD PARTY RIGHTS

Without limiting the generality of Section 2 above, BROADBAND FORUM ASSUMES NO RESPONSIBILITY TO COMPILE, CONFIRM, UPDATE OR MAKE PUBLIC ANY THIRD PARTY ASSERTIONS OF PATENT OR OTHER INTELLECTUAL PROPERTY RIGHTS

THAT MIGHT NOW OR IN THE FUTURE BE INFRINGED BY AN IMPLEMENTATION OF THE TECHNICAL REPORT IN ITS CURRENT, OR IN ANY FUTURE FORM. IF ANY SUCH RIGHTS ARE DESCRIBED ON THE TECHNICAL REPORT, BROADBAND FORUM TAKES NO POSITION AS TO THE VALIDITY OR INVALIDITY OF SUCH ASSERTIONS, OR THAT ALL SUCH ASSERTIONS THAT HAVE OR MAY BE MADE ARE SO LISTED.

All copies of this Technical Report (or any portion hereof) must include the notices, legends, and other provisions set forth on this page.

Issue Number	Approval Date	Publication Date	Issue Editor	Changes
1	8 April 2019	8 April 2019	Joey Boyd, ADTRAN Robert Peschi, Nokia Samuel Chen, Broadcom	Original
2	13 October 2020	13 October 2020	Joey Boyd, ADTRAN Robert Peschi, Nokia Igor Ternovsky, Broadcom	Add YANG model support for performance monitoring, power management, ONU presence states and defect reporting.

Comments or questions about this Broadband Forum Technical Report should be directed to info@broadband-forum.org.

Editors	Joey Boyd	ADTRAN
	Robert Peschi	Nokia
	Igor Ternovsky	Broadcom
Fiber Access Network Work Area Directors	Marta Seda	Calix
	Samuel Chen	Broadcom

Table of Contents

Executive Summary 8

1 Purpose and Scope..... 9

 1.1 Purpose..... 9

 1.2 Scope..... 9

2 References and Terminology 10

 2.1 Conventions10

 2.2 References10

 2.3 Definitions12

 2.4 Abbreviations.....13

 2.5 Figure Numbering Convention14

3 Technical Report Impact..... 15

 3.1 Energy Efficiency15

 3.2 IPv615

 3.3 Security.....15

 3.4 Privacy.....15

4 Introduction 16

 4.1 Objectives of the Model16

 4.2 Key principles and structure of the xPON model19

5 ITU-T PON YANG Modules 23

 5.1 Fundamentals23

 5.1.1 *xPON Interfaces related to the xPON Infrastructure* 23

 5.1.2 *xPON Interfaces related to individual ONUs*..... 24

 5.1.3 *T-CONTs*..... 26

 5.1.4 *Bidirectional GEM ports* 27

 5.1.5 *Model Instantiation* 31

 5.1.6 *Relationship with Other YANG Modules* 31

 5.2 Basic Operations33

 5.2.1 *ONU Activation and Authentication*..... 33

 5.2.2 *ONU presence on channel termination*..... 33

 5.2.3 *T-CONT, QoS and GEM Association* 36

 5.2.4 *Ethernet Service Configuration*..... 37

 5.2.5 *Upstream and downstream QoS*..... 40

 5.2.6 *Type B protection* 42

 5.2.7 *ONU Wavelength Mobility*..... 43

6 Modules..... 50

 6.1 General UML Model50

 6.2 xPON Modules and Sub-modules50

 6.2.1 *Generic set of xPON Modules and Submodules* 51

 6.2.2 *Set of (sub)modules applicable to {OLT-ONUs} Combined-NE* 56

 6.2.3 *Set of (sub)modules applicable to {OLT} Separated-NE* 57

 6.2.4 *Set of (sub)modules applicable to {ONU} Separated-NE* 58

7 Documentation 60

8 Dependencies on Related YANG Modules and Standards 61

Appendix I. Summary of Key Functions (Informative) 62

Appendix II. Guidelines and Examples (Informative)..... 64

 II.1 Examples 64

 II.1.1 *Infrastructure Configuration*..... 64

 II.1.2 *ONU Configuration*..... 65

 II.1.3 *T-CONT and GEM Port Configuration* 65

 II.1.4 *Strict Priority Upstream Scheduling Configuration* 66

 II.1.5 *IGMPv3 Transparent Snooping Function Configuration* 67

List of Figures

Figure 4-1/Figure 1 - {OLT – ONUs} Combined-NE mode.....	16
Figure 4-2/Figure 2 - {OLT} and {ONU}s Separated-NE mode	17
Figure 4-3/Figure 3 - Scope of TR-385 in TR-156 deployments.....	18
Figure 4-4/Figure 4 – Scope of TR-385 in TR-167 deployments.....	18
Figure 4-5/Figure 5 – Scope of TR-385 when deploying an IEEE 802.1 MAC Bridging ONU.....	19
Figure 4-6/Figure 6 – TR-156 case with UNIs and ANI mirrored on the OLT.....	20
Figure 4-7/Figure 7 – TR-167 Case with ONU-virtual-UNI and ANI mirrored on the OLT	20
Figure 4-8/Figure 8 – Case with an IEEE 802.1 MAC Bridging ONU	21
Figure 4-9/Figure 9 - TR-385 xPON YANG structure applied to Combined-NE Mode.....	22
Figure 4-10/Figure 10 - TR-385 xPON YANG structure applied to Separated-NE Mode.....	22
Figure 5-1/Figure 11 – Relation between ONU-virtual-UNI and ANI interfaces	26
Figure 5-2/Figure 12 – Several examples of upstream scheduling in a TR-156 ONU	29
Figure 5-3/Figure 13 – GEM ports for a host function in a TR-156 ONU.....	30
Figure 5-4/Figure 14 – GEM ports for a host function in a TR-167 ONU.....	30
Figure 5-5/Figure 15 – Relationship of xPON YANG Modules with Other Modules	32
Figure 5-6/Figure 16 - Interfaces and Hardware Entities Relationships	33
Figure 5-7 – ONU presence states on a channel termination	35
Figure 5-8/Figure 17 – ONU T-CONT Scheduling, Queueing and GEM Association	37
Figure 5-9/Figure 18 - Ethernet Service Model Example for TR-156 Application.....	38
Figure 5-10/Figure 19 - Ethernet Service Model Example for TR-142, TR-167 and TR-301 Applications	39
Figure 5-11/Figure 20 - Ethernet Service Model Example for IEEE 802.1 MAC Bridging ONU ...	40
Figure 5-12/Figure 21 – Upstream Scheduling and Queueing Model Example.....	41
Figure 5-13/Figure 22 – Downstream Scheduling and Queueing Model Example	42
Figure 5-14/Figure 23 – Support for Type B Protection	43
Figure 5-15/Figure 24 – Support for ONU WL Mobility.....	44
Figure 5-16/Figure 25 – Reference Architecture of an NG-PON2 system [from TR-352]	46
Figure 5-17/Figure 26 – An example of ICTP Interconnection Pattern.....	47
Figure 5-18/Figure 27 – Support of ICTP by xPON YANG model	48
Figure 5-19/Figure 28 – A detailed example of xPON YANG model instantiation for ICTP.....	49
Figure 6-1/Figure 29 – xPON YANG UML Model.....	50

Executive Summary

A goal of Software-Defined Networking (SDN) is to enable services providers to quickly respond to changing business requirements by defining a centralized architecture where the device management interfaces and data models are well defined and augmentable. New service requirements can then be introduced in a faster/agile and more error-free fashion. Standard Development Organizations and Industry Organizations have developed, and validated YANG data models focused on defining the device and service data models to be applied in the northbound interface of devices. This Technical Report supports BBF ongoing work toward developing standard YANG data models.

This Technical Report describes the YANG data models for ITU-T Passive Optical Networks (PON) devices as defined in ITU-T G.984.x, ITU-T G.987.x, ITU-T G.989.x, and ITU-T G.9807.x. The data models described in this Technical Report address the Optical Line Termination (OLT) and its subtending OMCI managed Optical Network Units (ONU). This data model reuses and in some cases augments existing IETF and BBF YANG models.

Future versions of this Technical Report may support other ONU deployment models, features, and PON technologies.

1 Purpose and Scope

1.1 Purpose

This Technical Report defines YANG data models for ITU-T Passive Optical Networks (PON) as defined in ITU-T G.984.x, ITU-T G.987.x, ITU-T G.989.x, ITU-T G.9807.x and potentially others. They are used in the Device Management Layer facing the northbound interface of the Optical Line Termination (OLT) and subtending Optical Network Units (ONU).

1.2 Scope

The data models defined by this Technical Report form the set of core models for PON management. They are referred as “ITU-T PON YANG Modules” throughout this document. The ITU-T PON YANG Modules address the configuration, fault management and performance management for Transmission convergence (TC) layer operation, Physical Media Dependent (PMD) layer parameters and PON link resources (e.g., Alloc-ID, GEM ports, ONU-ID).

It is intended that data models that are application specific can be built on, reference, and/or function alongside the ITU-T PON YANG Modules. For example, the BBF TR-383 [21] can be used along with the ITU-T PON YANG Modules to provision variety of services and features for PON, such as Ethernet services, equipment management, configuration management for the control plane functions (e.g., IGMP, DHCP).

The ITU-T PON YANG Modules allow optional components and future extensions.

2 References and Terminology

2.1 Conventions

In this Technical Report, several words are used to signify the requirements of the specification. These words are always capitalized. More information can be found in RFC 2119 [1].

MUST	This word, or the term “REQUIRED”, means that the definition is an absolute requirement of the specification.
MUST NOT	This phrase means that the definition is an absolute prohibition of the specification.
SHOULD	This word, or the term “RECOMMENDED”, means that there could exist valid reasons in particular circumstances to ignore this item, but the full implications need to be understood and carefully weighed before choosing a different course.
SHOULD NOT	This phrase, or the phrase "NOT RECOMMENDED" means that there could exist valid reasons in particular circumstances when the particular behavior is acceptable or even useful, but the full implications need to be understood and the case carefully weighed before implementing any behavior described with this label.
MAY	This word, or the term “OPTIONAL”, means that this item is one of an allowed set of alternatives. An implementation that does not include this option MUST be prepared to inter-operate with another implementation that does include the option.

2.2 References

The following references are of relevance to this Technical Report. At the time of publication, the editions indicated were valid. All references are subject to revision; users of this Technical Report are therefore encouraged to investigate the possibility of applying the most recent edition of the references listed below.

A list of currently valid Broadband Forum Technical Reports is published at www.broadband-forum.org.

Document	Title	Source	Year
[1] RFC 2119	<i>Key words for use in RFCs to Indicate Requirement Levels</i>	IETF	1997
[2] RFC 7950	<i>The YANG 1.1 Data Modeling Language</i>	IETF	2016
[3] RFC 6991	<i>Common YANG Data Types</i>	IETF	2013
[4] RFC 7317	<i>A YANG Data Model for System Management</i>	IETF	2014

[5]	RFC 7223	<i>A YANG Data Model for Interface Management</i>	IETF	2014
[6]	G.984.2 Amendment 2	<i>GPON: Physical Media Dependent (PMD) layer specification</i>	ITU-T	2008
[7]	G.984.3	<i>G-PON: Transmission convergence layer specification</i>	ITU-T	2014
[8]	G.987	<i>XG-PON systems: Definitions, abbreviations and acronyms</i>	ITU-T	2012
[9]	G.987.3	<i>XG-PON: Transmission convergence (TC) layer specification</i>	ITU-T	2014
[10]	G.988	<i>ONU management and control interface (OMCI) specification</i>	ITU-T	2012
[11]	G.989	<i>NG-PON2: Definitions, abbreviations and acronyms</i>	ITU-T	2015
[12]	G.989.2	<i>NG-PON2: Physical Media Dependent (PMD) layer specification</i>	ITU-T	2014
[13]	G.989.3	<i>NG-PON2: Transmission convergence layer specification</i>	ITU-T	2015
[14]	G.989.3 Amendment 1	<i>NG-PON2: Transmission convergence layer specification</i>	ITU-T	2016
[15]	G.9807.1	<i>10-Gigabit-capable symmetric passive optical network (XGS-PON)</i>	ITU-T	2016
[16]	TR-101 Issue 2	<i>Migration to Ethernet-Based Broadband Aggregation</i>	BBF	2011
[17]	TR-142 Issue 2	<i>Framework for TR-069 enabled PON Devices</i>	BBF	2010
[18]	TR-156 Issue 3	<i>Using GPON Access in the context of TR-101</i>	BBF	2012
[19]	TR-167	<i>GPON-fed TR-101 Ethernet Access Node</i>	BBF	2010
[20]	TR-301 Issue 2	<i>Architecture and Requirements for Fiber to the Distribution Point</i>	BBF	2017
[21]	TR-383	<i>Common YANG Modules</i>	BBF	2017
[22]	TR-352	<i>Multi-wavelength PON Inter-Channel-Termination Protocol (ICTP) Specification</i>	BBF	2017
[23]	802.1Q	<i>Virtual bridged local area networks</i>	IEEE	2018
[24]	802.1D	<i>Media access control (MAC) bridges</i>	IEEE	2014

2.3 Definitions

The following terminology is used throughout this Technical Report.

Model	A data model.
Module	Refer to [2].
Submodule	Refer to [2].
Channel Group	A set of channel pairs carried over a common fiber, as defined in ITU-T G.989 [11].
Channel Pair	A set of one downstream wavelength channel and one upstream wavelength channel that provides connectivity between an OLT and one or more ONUs, as defined in ITU-T G.989.
Channel Partition	Any of the operator-specified non-overlapping subsets of TWDM or PtP WDM channels in an NG-PON2 system, as defined in ITU-T G.989.
Channel Termination	Refer to ITU-T G.989. In the G-PON, XG-PON, or XGS-PON context, the term channel termination refers to a logical function associated with an OLT port that terminates an xPON.
Optical Distribution Network (ODN)	A point-to-multipoint optical fiber infrastructure, as defined in ITU-T G.989.
Optical Line Termination (OLT)	A network element in an ODN-based optical access network that terminates the root of at least one ODN and provides an OAN SNI, as defined in ITU-T G.989.
Optical Network Unit (ONU)	A network element in an ODN-based optical access network that terminates a leaf of the ODN and provides an OAN UNI as defined in ITU-T G.989.
G-PON Encapsulation Method (GEM) Port	A GEM Port as defined in ITU-T G.984.3. In TR-385, the term “GEM” is also used generically to include ITU-T G.987.3, G.989.3 and G.9807.1 “XGEM”.
TR-156 ONU	An ONU as defined in TR-156 [18]. It has physical UNIs attached to subscribers. The OLT has visibility of each individual TR-156 ONU UNI.
TR-167 ONU	An ONU entity as defined in TR-167 [19]. It provides an interface at the V reference point for a TR-101 [16] access node. The OLT may not have visibility of each TR-101 access node UNI. If several V reference points are present on the TR-167 ONU, the OLT has visibility of each individual V reference point.
IEEE 802.1 MAC Bridging ONU	An ONU with IEEE 802.1 MAC bridging function. An IEEE 802.1 MAC Bridging ONU performs MAC address learning and frame forwarding process as described in IEEE 802.1D [24] and 802.1Q [23].
Type B Protection	Type B protection configuration involves a single channel group where each individual channel pair has two OLT channel terminations, as defined in ITU-T G.989.

Type WL Protection	Type WL refers to a PON protection architecture that is exclusive to multi-wavelength PON systems, is dependent on availability of at least two OLT CTs operating on different downstream and upstream wavelength channels while being attached to one and the same ODN, and allows to protect against the failure of one OLT CT and/or of the segment of fiber specific to that OLT CT by retuning the affected ONUs to the downstream and upstream wavelength channels associated with another OLT CT as defined in TR-352 [22].
xPON	xPON is a generic term used to denote any ITU-T PON variant such as G-PON, XG-PON, XGS-PON, NG-PON2.

2.4 Abbreviations

This Technical Report uses the following abbreviations:

AES	Advanced Encryption Standard
Alloc-ID	Allocation Identifier
ANI	Access Network Interface
BE	Best Effort
BER	Bit Error Ratio
CG	Channel Group
CIR	Committed Information Rate
CP	Channel Pair
CT	Channel Termination
DBA	Dynamic Bandwidth Assignment
EIR	Excess Information Rate
FEC	Forward Error Correction
GEM	G-PON Encapsulation Method
G-PON	Gigabit Passive Optical Network
ICTP	Inter Channel Termination Protocol
IP	Internet Protocol
IPv4	Internet Protocol version 4
IPv6	Internet Protocol version 6
NE	Network Element
NG-PON2	Next Generation Passive Optical Network 2
OAM	Operations, Administration and Maintenance
OAN	Optical Access Network
ODN	Optical Distribution Network
OLT	Optical Line Termination
OMCI	Optical Network Unit Management and Control Interface
ONT	Optical Network Termination
ONU	Optical Network Unit
PIR	Peak Information Rate
PM	Performance Monitoring
PMD	Physical Media Dependent
PON	Passive Optical Network
P2P	Point-to-Point

QoS	Quality of Service
SDN	Software-Defined Networking
SDO	Standard Development Organization
SN	Serial Number
SNI	Service Node Interface
TC	Transmission Convergence
T-CONT	Transmission Container
TOD	Time of Day
TR	Technical Report
UC	Use Case
UML	Unified Modeling Language
UNI	User-Network Interface
VLAN	Virtual Local Area Network
WDM	Wavelength Division Multiplexing
WL	Wavelength
WLCP	Wavelength Channel Protection
XGEM	XG-PON Encapsulation Method
XG-PON	10 Gigabit Passive Optical Network
XGS-PON	10-Gigabit-capable Symmetric Passive Optical Network
XGTC	XG-PON Transmission Convergence

2.5 Figure Numbering Convention

The Technical Report TR-385 Issue 1 used a sequential numbering for all figures throughout the text. This convention changed starting from TR-385 Issue 2. Now all figures are numbered as “Figure SN-FN”, whereas SN is the section number, FN is the figure number in the chapter. In cases where the figure was present in TR-385 Issue 1, the new figure number also includes ‘/Figure OLDFN’ to simplify tracking, whereas “OLDFN” is the figure number in TR-385 Issue 1.

3 Technical Report Impact

3.1 Energy Efficiency

TR-385 has no impact on energy efficiency.

3.2 IPv6

TR-385 has no impact on IPv6.

3.3 Security

TR-385 has no impact on security.

3.4 Privacy

Any issues regarding privacy are not affected by TR-385.

4 Introduction

4.1 Objectives of the Model

The xPON YANG model fulfills the following objectives:

- The model is intended to be used in the Device Management Operations, Administration and Maintenance (OAM) Layer of the OLT and ONUs. In other words, it is the YANG model closest to the Northbound OAM Interface of the physical OLT and ONU devices. As such it is able to exploit the finest programmability level of the OLT and ONU physical devices in various xPON deployments modes.
- The model supports ITU-T PON variants defined in ITU-T G.984.x (G-PON), ITU-T G.987 (XG-PON), ITU-T G.989 (NG-PON2), and ITU-T-G.9807 (XGS-PON). The model is designed to be flexible and accommodate future next generation ITU-T PON technologies. Because of the need to define a model with a single concept/procedure for all xPON variants, the model makes exceptions for specific xPON types only when it is functionally not possible to support a function (for example, a PON-type dependent exception is the PON-ID syntax).
- It is possible to use the model in either of the following management modes:
 - **Combined-NE mode:** managing the OLT and subtending ONUs as one single combined {OLT-ONUs} network element (NE), i.e., having a single NETCONF management interface. The model and its NETCONF management interface are hosted by the OLT. This Technical Report does not specify the management interface between the OLT and the ONU physical entities; it can be OMCI [10] or other protocols. Figure 4-1 illustrates the {OLT - ONUs} Combined-NE mode.

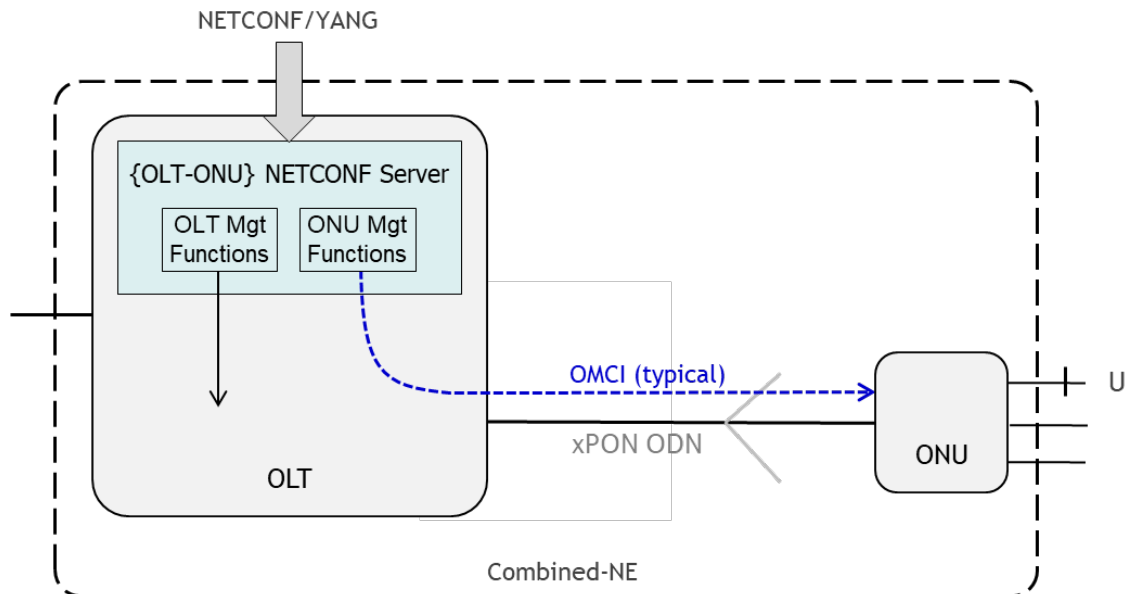
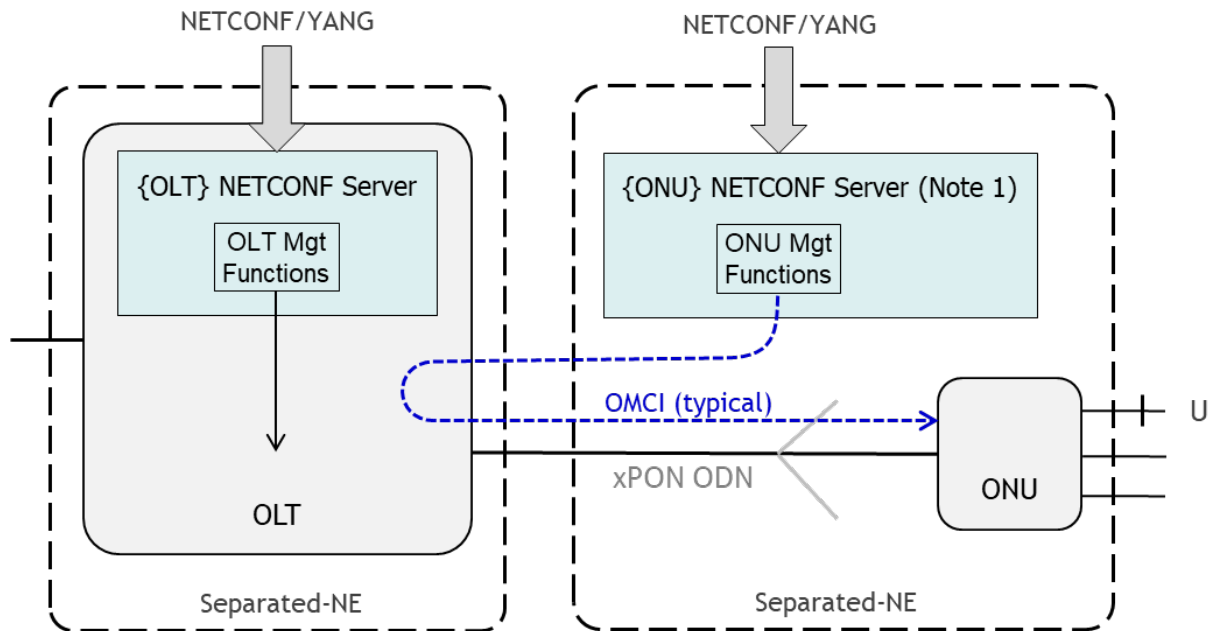

Figure 4-1/Figure 1 - {OLT – ONUs} Combined-NE mode

- Separated-NE mode:** managing the OLT and ONUs as separate NEs, each NE has its own NETCONF management interface. The separated-NE mode can be used in some deployment architecture, for instance when ONU management functions are virtualized in the cloud. Similar to the Combined-NE mode, this Technical Report does not specify the management interface between the OLT and the ONU physical entities; it can be OMCI or other protocols. Figure 4-2 illustrates the Separated-NE mode.



(Note 1) The {ONU} NETCONF server can be located anywhere, e.g. in the OLT or in the Cloud

Figure 4-2/Figure 2 - {OLT} and {ONU}s Separated-NE mode

- The model supports TR-156 [18] and TR-167 [19]:
 - The ONU (per TR-156) or the ONU entity (in the sense of Figure 4 of TR-167) is responsible for user-facing functions (e.g., VLAN manipulations) and traffic mapping between UNIs and GEM ports, whereas the OLT is the first aggregation point in the xPON access network (refer to Section 4.4 of TR-156). Because in TR-156 the ONU relates GEM ports with UNIs, the OLT is able:
 - In the upstream, to deduce the UNIs from which frames are received, and
 - In the downstream, to let the ONU know the UNIs through which frames should be egressed.
 - A TR-156 ONU and a TR-167 ONU entity are functionally similar, except that a TR-156 ONU has physical UNIs attached to subscribers (refer to “U reference point” in Section 4 of TR-156), while a TR-167 ONU entity has a “virtual UNI” functionally attached to the TR-101 [16] access node function (refer to “virtual V reference point”

in Sections 4 and 4.1 of TR-167). The “virtual UNI” is also similarly discussed in Section 6.1 of TR-142 [17] and Sections 5.2 and 10.1 of TR-301 [20].

- In the context of TR-167, the ONU entity is managed by the OLT using OMCI, while the TR-101 access node function is independently managed, the same way as for an access node with a physical Ethernet at the V reference point.
- The model also supports ONUs that perform source MAC address learning and frame forwarding process as described in 802.1D [24] and 802.1Q [23]. This type of ONU will be denoted as “IEEE 802.1MAC Bridging ONU”.

Figure 4-3, Figure 4-4, and Figure 4-5 illustrate these different possibilities that the xPON YANG model can accommodate.

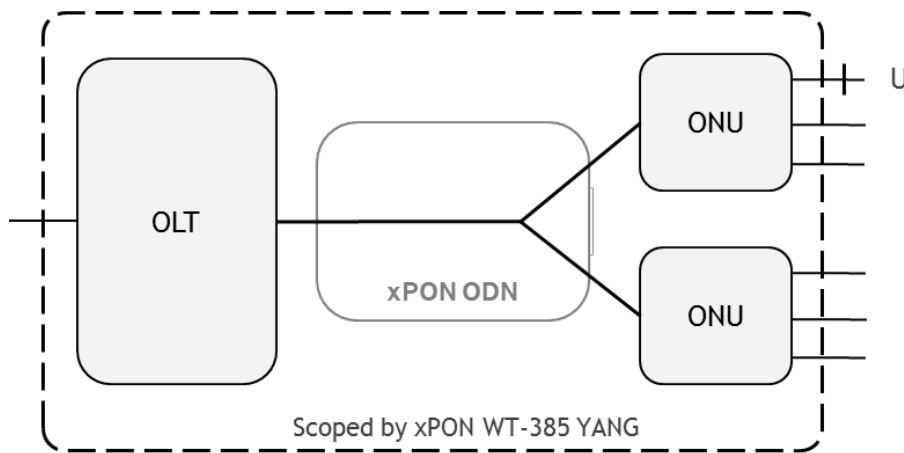

Figure 4-3/Figure 3 - Scope of TR-385 in TR-156 deployments
(Derived from TR-156 – Figure 1)

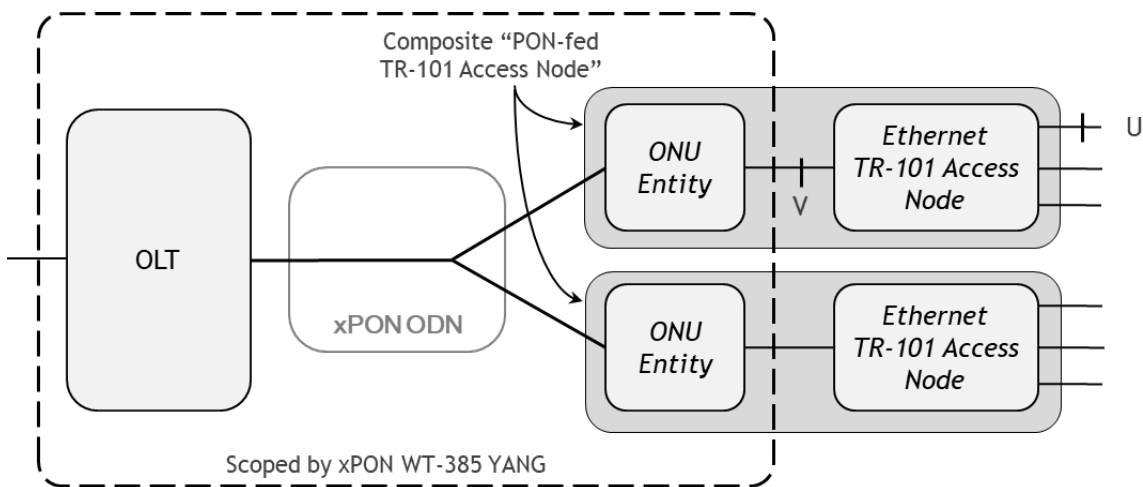

Figure 4-4/Figure 4 – Scope of TR-385 in TR-167 deployments
(Derived from TR-167 – Figure 1)

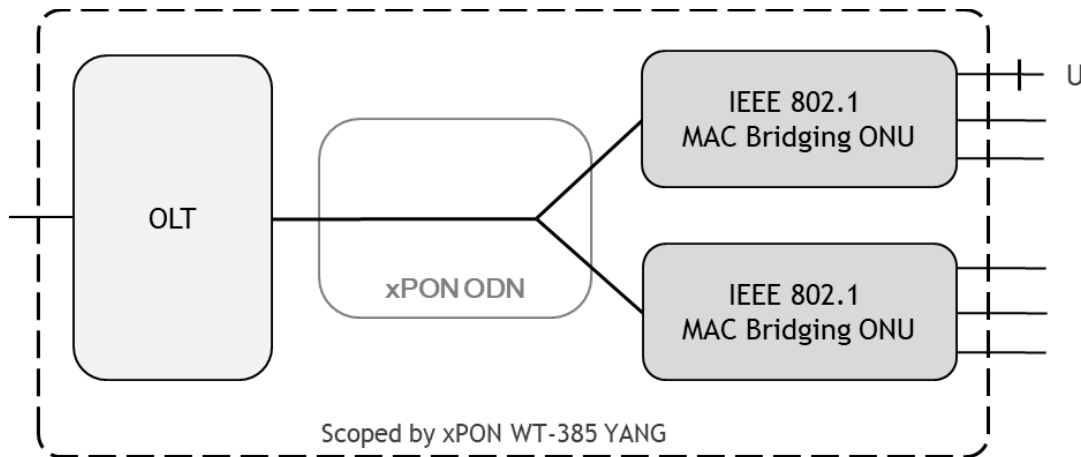

Figure 4-5/Figure 5 – Scope of TR-385 when deploying an IEEE 802.1 MAC Bridging ONU

4.2 Key principles and structure of the xPON model

Since it is the model closest to the devices, the model is able to exploit the finest programmability level available for the OLT and ONU devices. In order to fulfill its objectives, the xPON YANG model is articulated around the following principles and structure:

- The model requires the Management layer NETCONF Client to configure the interfaces and other data structures between the OLT and the ONUs, such as GEM Ports, T-CONTs, and the virtual entities in the OLT that represent the ONU interfaces (ANI and UNI interfaces). This allows the model to make a clear and explicit separation between OLT functions and ONU functions. This separation is instrumental to the support of the Combined- and Separated-NE modes.

This approach might be viewed as incongruous with TR-156 management requirement on GEM Port Identifier assignment (R-5 in TR-156). While it is true that the GEM Port name has to be configured in the model by the Management layer NETCONF Client, the model allows the following possibilities for the allocation of the GEM Port Identifier, though:

- The NETCONF Client can configure the OLT to auto-assign the GEM Port Identifier to the GEM Port name
- OR
- The NETCONF Client can individually configure the GEM Port Identifier to the GEM Port name.

Once the GEM Port name has an assigned GEM Port Identifier, the OLT can use the management interface between OLT and ONU to assign GEM Port Identifiers to the ONU.

As will be further discussed in the next sections, the Combined-NE mode makes use of the “link table” to relate ONU interfaces with their virtual representations in the OLT.

Figure 6, Figure 7, and Figure 8 illustrate a few examples.

Figure 4-6 illustrates a TR-156 ONU (no IEEE 802.1 MAC Bridging function) with the OLT containing a virtual entity of the ONU (represented by its ANI interface) and its physical UNIs, being respectively the vANI and OLT-vENET.

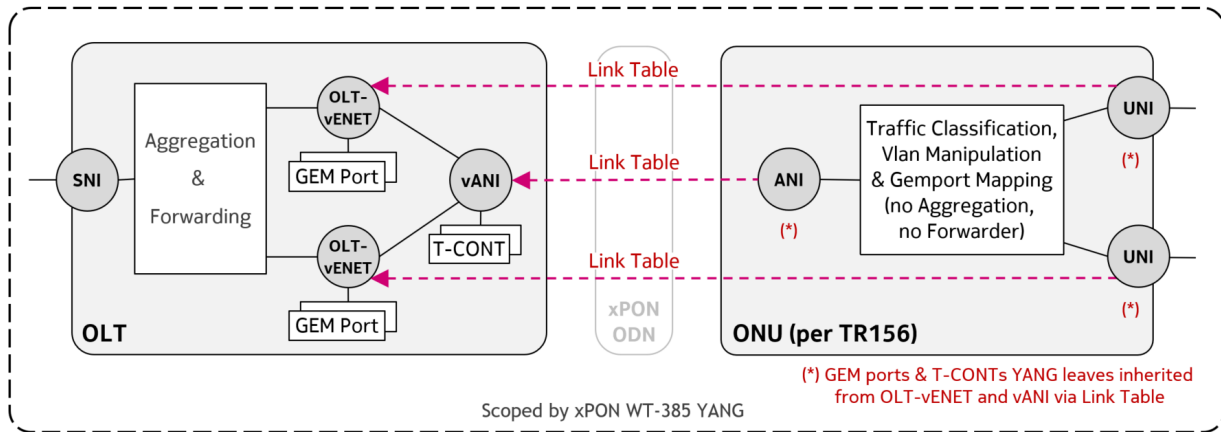

Figure 4-6/Figure 6 – TR-156 case with UNIs and ANI mirrored on the OLT

Figure 4-7 illustrates the case of the TR-167 composite PON-fed access node, with the OLT containing a virtual entity of the ONU function (represented by its ANI interface) and its ONU-virtual-UNI, being respectively the vANI and OLT-vENET. It should be noted that it is possible that more than one ONU-virtual-UNI exists in PON-fed access node.

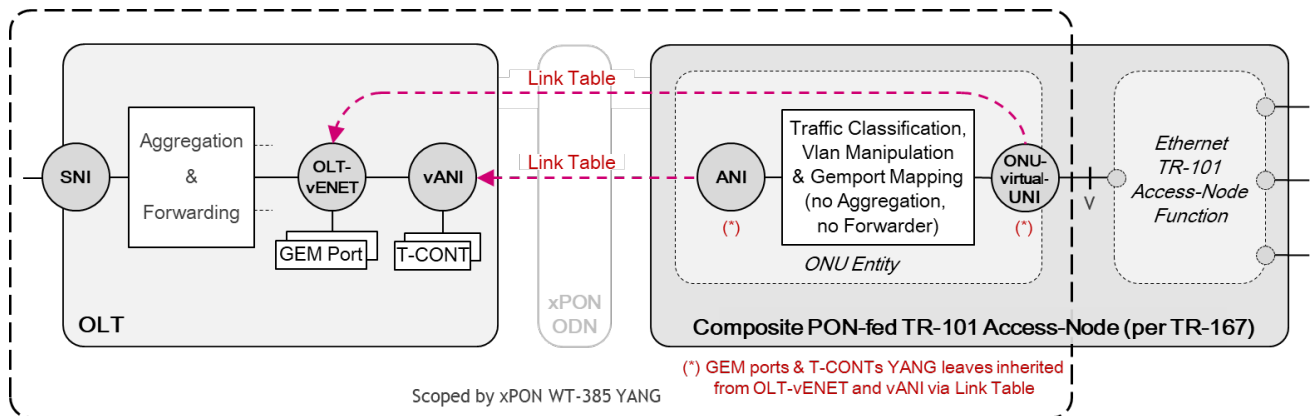

Figure 4-7/Figure 7 – TR-167 Case with ONU-virtual-UNI and ANI mirrored on the OLT

Figure 4-8 illustrates the case of an IEEE 802.1 MAC Bridging ONU with the OLT containing a virtual entity of the PON-fed access node (represented by its ANI interface) and the PON-facing ONU-vENET aggregating interface(s), being respectively the vANI and OLT-vENET. It should be noted that it is possible that more than one ONU-vENET may exist in an IEEE 802.1 MAC Bridging ONU.

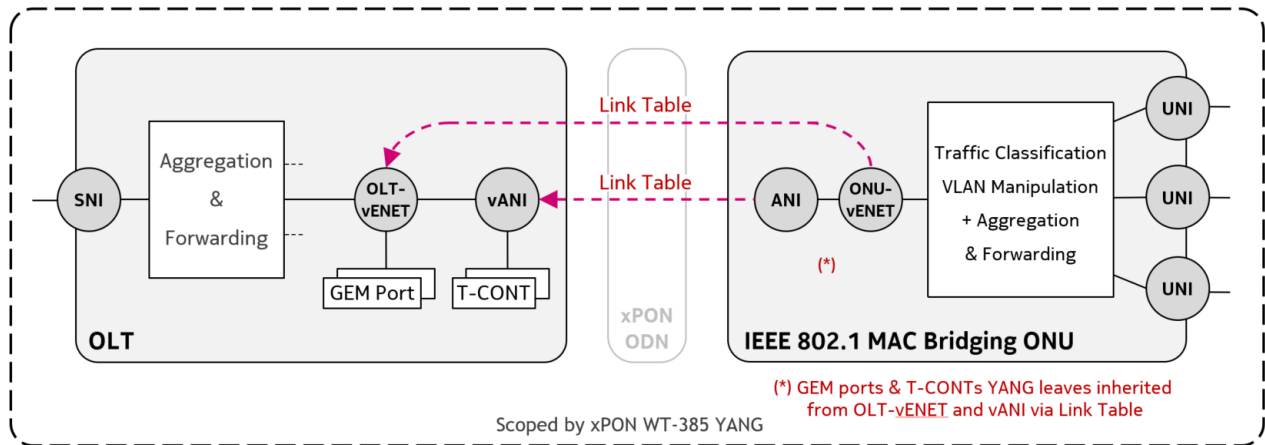

Figure 4-8/Figure 8 – Case with an IEEE 802.1 MAC Bridging ONU

- The model defines and structures objects and parameters as follows:
 - The objects and parameters related to the xPON infrastructure, i.e., the objects that the OLT needs and are shared by several or all ONUs. Examples of such objects are: channel group, channel partition, channel pair, and channel termination.
 - The objects and parameters related to individual ONUs that the physical ONU devices need for their own local purpose. The objects in the YANG model that are related to the physical and logical entities of an individual ONU, such as the UNI and ANI, are typically translated to OMCI objects (and conversely for state related objects). Examples of such objects are the data related to the physical UNI and the ONU device itself materialized by its ANI interface in the YANG model.
 - The objects and parameters related to individual ONUs that the physical OLT device needs for its own local purpose. Examples of such objects are the virtual entities that shadow the ONU interfaces (ONU ANI and ONU UNI)”. The virtual entity of the expected physical ONU device is modelled as “vANI”, and the virtual entities representing the ONU interfaces (for instance in TR-156, the ONU physical UNIs), which the OLT locally maintains, are modeled as “olt-v-enet”. Also included are the associated GEM ports and T-CONTs.

In TR-156 and TR-167 the OLT and ONUs are considered as a single combined NE. In TR-385 this single combined NE corresponds to a single YANG model instance. In this case it is necessary in the Combined-NE mode to configure the correspondence between each “vANI” and the corresponding “ANI” of the physical ONU and between each “olt-v-enet” and its corresponding interface on the physical ONU.

This linking from an “entity” in the ONU to its corresponding “virtual entity” in the OLT is necessary, so that for each ONU and its relevant interfaces, it is straightforward to retrieve the applicable T-CONTs (defined on the “vANI”) and GEM ports (defined on the “olt-v-enet”).

To support that purpose, the “link table” in the YANG model is intended to be

configured with entries from an “entity” in the physical ONU to its corresponding virtual entity in the OLT.

Note: When the OLT and ONUs are separately managed NEs, a YANG model instance exists for each of the OLT and ONU separately. Since each YANG model instance is self-supporting, T-CONTs and GEM ports are configured both in the OLT and ONU YANG instances making the “link table” not applicable.

- The structure of TR-385 xPON YANG model is shown in Figure 4-9 and Figure 4-10. The intent of the data organization is that it is suited to support both the Combined-NE mode and Separated-NE Mode.

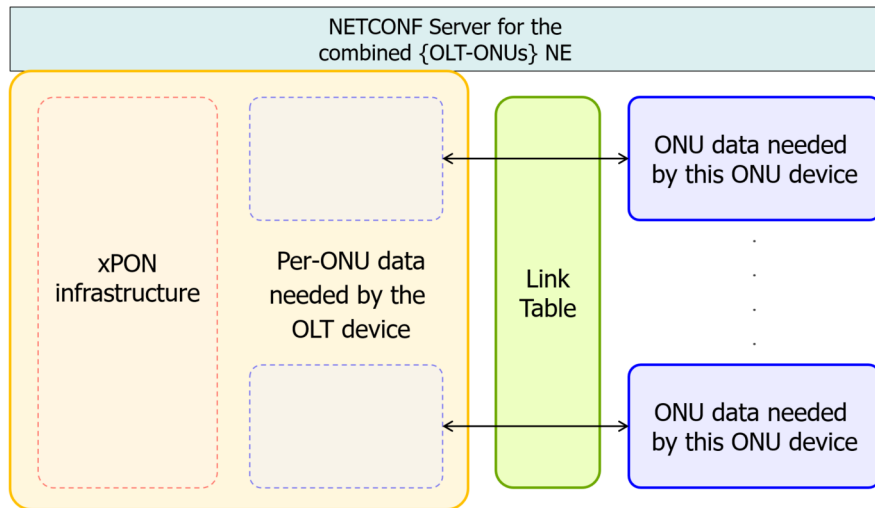

Figure 4-9/Figure 9 - TR-385 xPON YANG structure applied to Combined-NE Mode

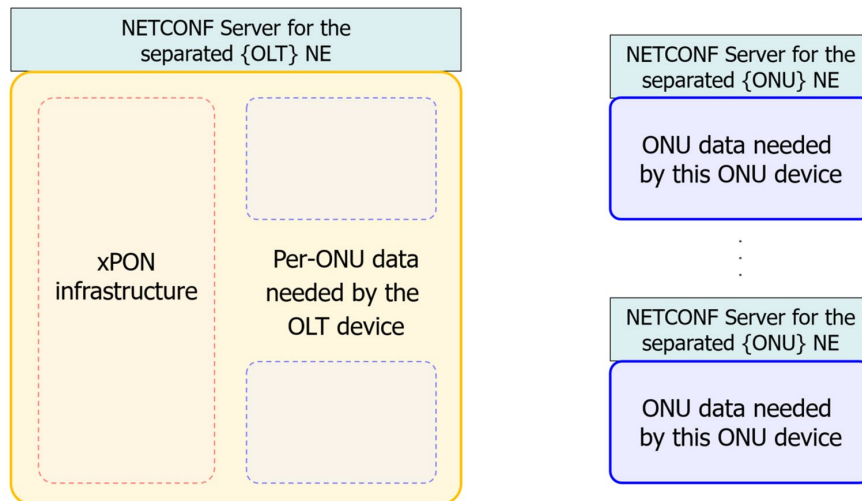

Figure 4-10/Figure 10 - TR-385 xPON YANG structure applied to Separated-NE Mode

5 ITU-T PON YANG Modules

5.1 Fundamentals

5.1.1 xPON Interfaces related to the xPON Infrastructure

The ITU-T PON YANG Modules contain a collection of augmentations to ietf-interfaces [5] related to the xPON infrastructure. The presence of such augmentation indicates the interface type, and holds the corresponding configuration and operational state data:

- **Channel group:** xPON channel group as defined in ITU-T G.989 [11].
- **Channel partition:** xPON channel partition as defined in ITU-T G.989.
- **Channel pair:** xPON channel pair as defined in ITU-T G.989.
- **Channel termination:** xPON channel termination as defined in ITU-T G.989.

The channel group is the resource which 1:1 relates to the ODN feeder, it globally aggregates all the available optical capacity of the xPON access system. In NG-PON2, a channel group is usually provisioned with a number of distinct wavelength resources, the channel pairs. On a given channel group, there cannot be two channel pairs using the same wavelength.

Each channel pair consists in one or two channel termination(s). A channel termination is an actual physical resource belonging to a specific OLT. Provisioning a channel pair with two channel terminations allows the channel pair to be Type-B protected, see Section 5.2.6 for details).

The configuration of channel pairs (with their channel termination(s)) to a channel group relates to physical resource provisioning: it typically involves a technician connecting physical equipment to the infrastructure, for instance connecting a channel termination to the wavelength multiplexer in the OLT central office basement. Hence it is a relatively static configuration.

The channel group is logically partitioned into non-overlapping channel partitions under arbitrary operator criteria (refer to G.989.3 Clause 6.1.5.9 [13]). Further, each channel partition is configured with a subset of the channel pairs available in the channel group. “Non-overlapping channel partitions” means that a channel pair can belong to only one channel partition at most.

Channel partitions allow implementing service segregation on the xPON access infrastructure. There are a countless number of possible use cases. For instance, an xPON Access Operator may decide to wholesale the channel group access capacity to different Service Providers, each one operating in its own channel partition. Another example is when the xPON Access Operator would want to cluster business ONUs in a given channel partition and residential ONUs in another channel partition.

In contrast to configuring channel pairs in a channel group, configuring channel pairs to channel partitions (and even configuring channel partitions themselves) does not involve physical equipment manipulation and can be frequently updated, for instance as a result of commercial considerations. It is also possible that some channel pairs are commissioned in the infrastructure (i.e., configured on the channel group) but temporarily not used in any channel partition (they can be, for example, spare capacity or capacity de-allocated from a channel partition if not needed any longer by a Service Provider hiring the channel partition).

To summarize, a channel partition can be seen as a unit offering a homogeneous xPON access service with a bandwidth determined by the number of channel pairs it contains and to which ONUs can be subscribed.

Within a channel partition, an ONU can use any single channel pair at a time. Which specific channel pair an ONU uses at a particular time does not matter and can even change over time, as this forms the basis for the ONU Wavelength Mobility uses cases in ITU-T G.989.3 appendix VI and TR-352 [22] (ONU WL Mobility is covered in more details in Section 5.2.7).

The YANG model reflects the above principles by mandating that any ONU is always statically configured on the channel partition – as an invariant subscribed access service - and never directly on a specific channel pair or channel termination.

The channel group, channel partition, channel pair and channel termination concepts originally defined for NG-PON2 are also workable for G-PON, XG-PON and XGS-PON for all OAM functions even if not strictly necessary for the latter cases. In line with the model objectives listed in Section 4.1, the model imposes that all ITU-T PON variants make use of channel group, channel partition, channel pair and channel termination. Non-G.989.x systems are considered as a special case of ITU-T G.989.x with one Channel Pair and one Channel Partition.

Similarly, an ONU is always be configured on a channel partition and never directly on a specific channel pair or channel termination, even in the case of G-PON, XG-PON or XGS-PON.

5.1.2 xPON Interfaces related to individual ONUs

The ITU-T PON YANG Modules contain a collection of augmentations to ietf-interfaces [5] related to individual ONUs and related interfaces. The presence of such augmentation indicates the interface type and holds the corresponding configuration and operations state data.

- **ANI**

The ANI interface belongs to the ONU and represents the Physical ONU device in the YANG model. Configured objects and parameters related to an ANI are those needed by this specific ONU device for its own purpose and which are typically translated to OMCI Managed Entities (ME).

Similarly, the state objects related to the ANI are objects which value is provided by the ONU device typically via OMCI.

In general, several OLTs will contribute Channel-Terminations to a given channel group. For proper xPON operation, ONU IDs must be uniquely allocated on the channel group.

If the YANG feature “configurable-ani-onu-id” is supported on the device, ONU IDs can be centrally and individually allocated outside the OLTs by the OAM device layer which configures them to the ANI of the xPON YANG model.

If the YANG feature “pon-pools” is supported on the device, the management layer can allocate non-overlapping PON resources (GEM port IDs, Alloc-IDs and ONU-IDs) to several OLTs belonging to the same channel group.

- **vANI**

The vANI interface is a virtual interface belonging to the OLT and which represents the ONU as seen from the perspective of the OLT. Configured objects and parameters related to a vANI are used by the OLT to represent ONU objects and parameters.

Similarly, the state objects related to the vANI are objects which the OLT is able to provide on its own behalf to the OAM system about this ONU.

vANI are virtual interfaces in the sense that they are no direct physical interface of the OLT. Instead, vANI interfaces are configured on top of a channel partition as explained in Section 5.1.1.

In general, several OLTs will contribute Channel-Terminations to a given channel group. For proper xPON operation, ONU IDs must be uniquely allocated on the channel group.

If the YANG feature “configurable-v-ani-onu-id” is supported on the device, ONU IDs can be centrally and individually allocated outside the OLTs by the OAM device layer which configures them to the vANI of the xPON YANG model.

If the YANG feature “pon-pools” is supported on the device, the management layer can allocate non-overlapping ONU-IDs to several OLTs belonging to the same channel group.

- **ONU-vENET**

The ONU-vENET interfaces are virtual interfaces belonging to the ONU device, which carry Ethernet frames, and which are facing the xPON side of the ONU i.e., facing the OLT. ONU-vENETs are NOT facing the user side of the ONU.

ONU-vENETs are virtual interfaces in the sense that they are no direct physical interface of an ONU. Instead, ONU-vENET interfaces are configured on top of the ANI interface of the ONU, from an interface stack point of view.

An ONU-vENET is typically used as the xPON side Ethernet aggregation interface of an IEEE 802.1 MAC Bridging ONU which performs Ethernet traffic aggregation from several user-facing interfaces as depicted in Figure 4-8.

- **OLT-vENET**

The OLT-vENET interfaces are virtual interfaces belonging to the OLT, which carry Ethernet frames, and which are facing the xPON side of the OLT i.e., facing the ONU.

Generally speaking, OLT-vENETs are virtual entities in the OLT representing ONU interfaces:

- For TR-156 [18] case, there is a direct correspondence between an OLT-vENET interface and an individual physical UNI interface in the ONU, as illustrated in Figure 4-6.
- For TR-167 [19] case, there is a direct correspondence between an OLT-vENET interface and an individual virtual UNI interface in the ONU, as illustrated in Figure 4-7.
- An OLT-vENET interface can also directly correspond to an ONU-vENET interface in the ONU, as depicted in Figure 4-8 and Figure 5-3.
- From the interface stack point of view, the OLT-vENET interface stands on top of the vANI interface

- **ONU-virtual-UNI**

The ONU-virtual-UNI is a virtual interface carrying Ethernet frames which is found in the composite PON-fed access nodes modeled in TR-167. More precisely, the ONU-virtual-UNI interface belongs to the ONU function and implements the virtual V reference point between the ONU function and the TR-101 access node [16] function, as depicted in Figure 4-4 and Figure 4-7 and also illustrated in TR-167 Section 4 and 4.1.

They are virtual interfaces in the sense that they are no direct physical interface of an ONU function.

ONU-virtual-UNI interfaces are facing the user side from the ONU function point of view and are virtual equivalents of the physical UNIs at the U reference point of TR-156 ONUs (refer to Section 4 of TR-156 [18]). ONU-virtual-UNIs are also matching the “virtual UNI” concept discussed in TR-142, Section 6.1 [17]. In the YANG modules the ONU-virtual-UNI is called “onu-v-vrefpoint”

ONU-virtual-UNI interfaces refer to the ANI interface of the ONU function. Note however that there is no upper/lower stack relation between the ONU-virtual-UNI and the ANI interfaces as shown in Figure 5-1:

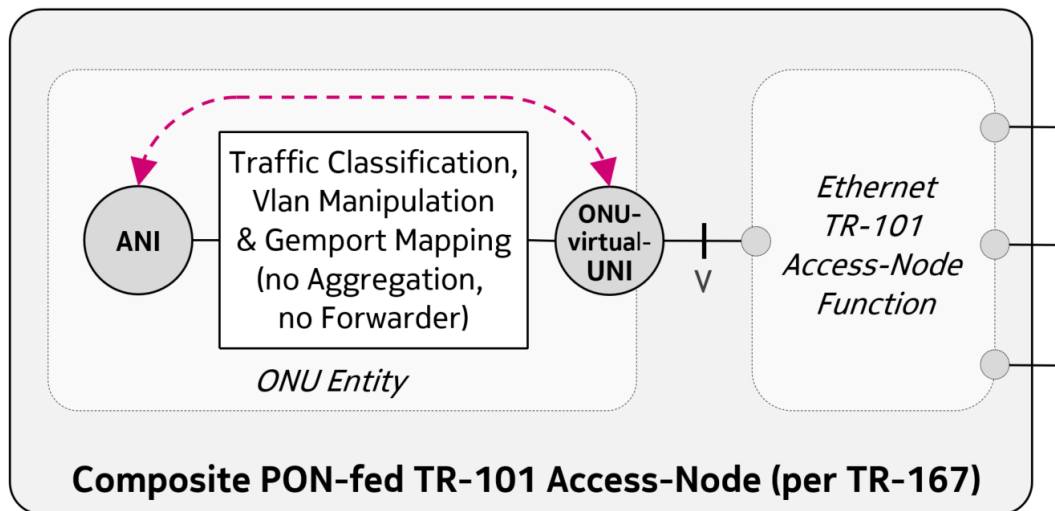

Figure 5-1/Figure 11 – Relation between ONU-virtual-UNI and ANI interfaces

5.1.3 T-CONTs

All ITU-T PONs make use of T-CONTs for managing and controlling the upstream bandwidth available for each individual ONU. The OLT must be configured with one or several T-CONTs per ONU (i.e., per vANI) with each T-CONT characterized by its traffic descriptor parameters. A T-CONT is an upstream bandwidth resource in the ONU, requiring queuing and traffic scheduling. When TR-385 is used in association with TR-383 [21], a T-CONT in TR-385 is augmented by a TM-Root defined in TR-383 (refer to Figure 5-2).

Both the OLT and ONU must be aware of the T-CONTs:

- In combined NE mode, the T-CONTs are configured only once on the vANI in the {OLT-ONUs} YANG instance and then indirectly inherited towards the corresponding ANI interface by means of the link table.
- In separated mode, the T-CONTs must be configured on both the vANI of the {OLT} YANG instance and on the ANI of the {ONU} YANG instance.

In general, several OLTs will contribute Channel-Terminations to a given channel group. For proper xPON operation, T-CONTs ALLOC-IDs must be uniquely allocated on the channel group.

If the YANG feature “configurable-alloc-id” is supported on the device, Alloc-IDs can be centrally and individually allocated outside the OLTs by the OAM device layer which configures them to the OLT/ONU xPON YANG model.

If the YANG feature “pon-pools” is supported on the device, the management layer can allocate non-overlapping Alloc-IDs to several OLTs belonging to the same channel group.

5.1.4 Bidirectional GEM ports

All ITU-T PONs make use of Bidirectional point-to-point (X)GEM Ports (also called (X)GEM Channels) encapsulating individual Ethernet frame traffic exchanged over the ODN (refer to ITU-T G.984.3, G.989.3, and BBF TR-156 Section 5.1].

The YANG model for GEM ports is largely driven to support TR-156:

- Each GEM port is identified by an ODN wide identifier, the GEM port ID.
- A GEM port is used both in upstream and downstream direction and is usually AES encrypted with a key which is specific per ONU.
- TR-156 Section 5.1 states that “each GEM Port carries one or more traffic flows associated with a specific traffic class going to a specific U interface on a specific ONU”
- A GEM Port is mapped into one and only one T-CONT (TR-156, Section 5.1). This is used in the ONU for upstream frame scheduling
- A GEM Port is related to a specific traffic class.

Figure 5-2/Figure 12 a) illustrates the mapping of GEM port assignment in the case of TR-156 architecture. However, TR-385 YANG model is not limited to TR-156 architecture and it is also possible to perform different GEM port/T-CONT assignment. Figure 5-2/Figure 12 b) and c) illustrate other examples of upstream traffic mapping schemes beyond TR-156.

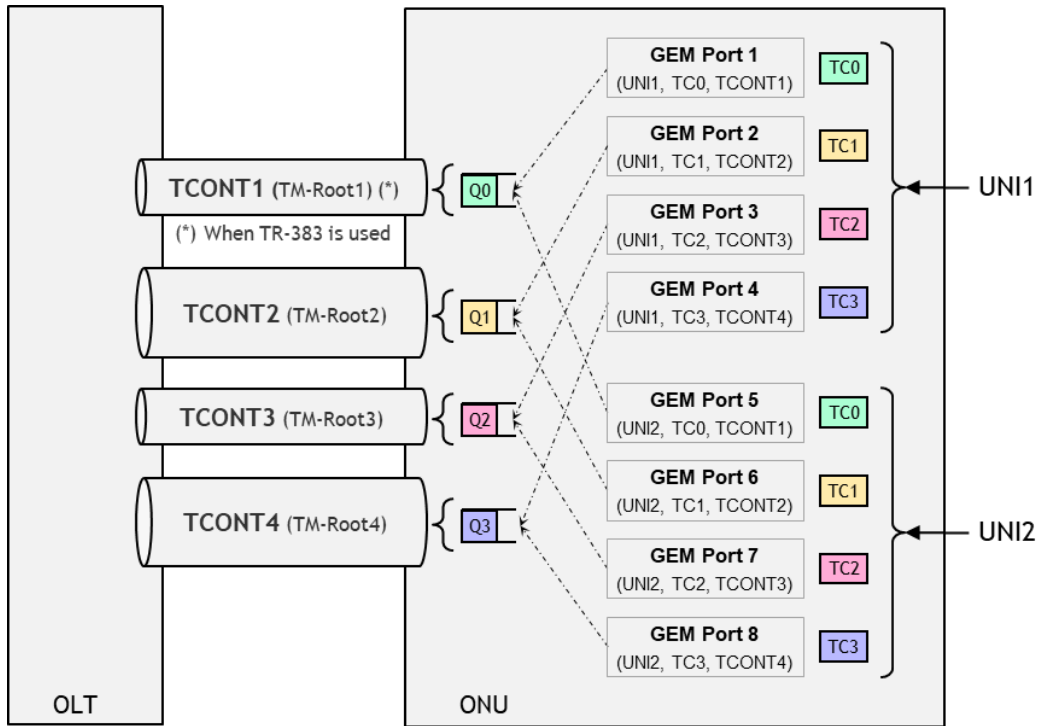

a) Upstream traffic mapping per TR-156

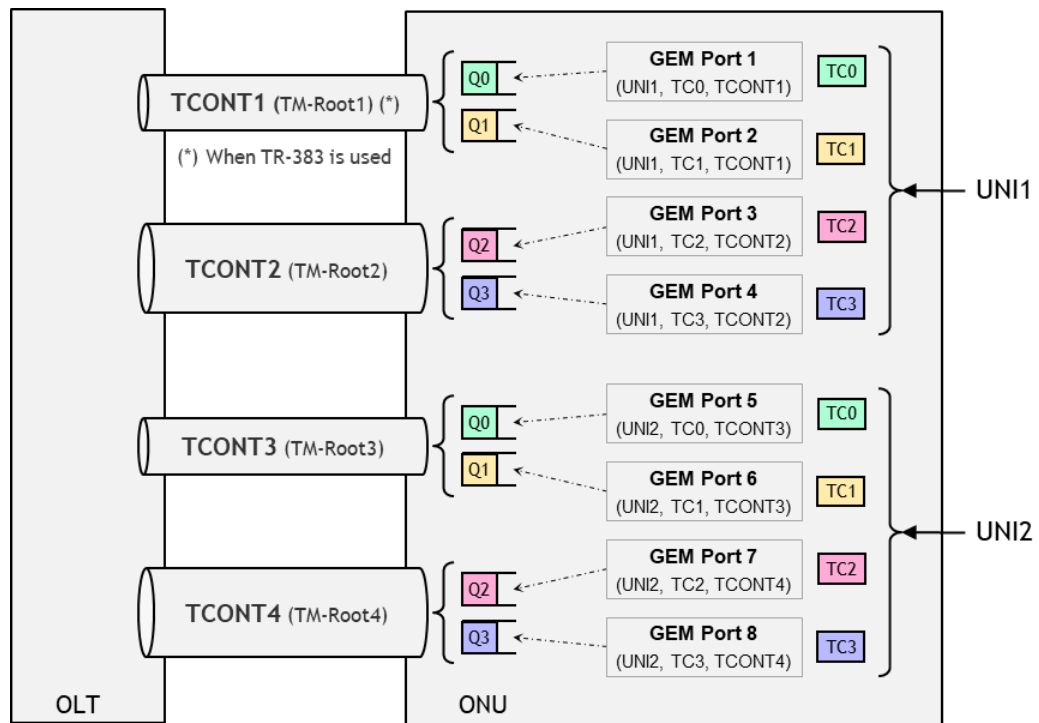

b) An example of traffic mapping beyond TR-156

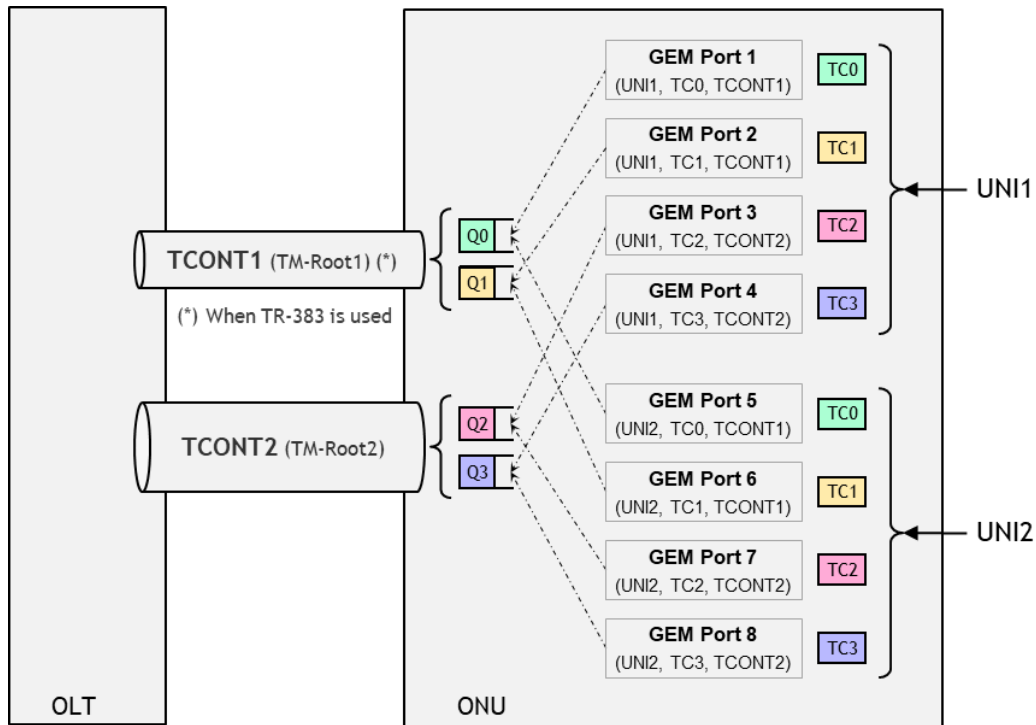

c) Another example of traffic mapping beyond TR-156

Figure 5-2/Figure 12 – Several examples of upstream scheduling in a TR-156 ONU

It is important to realize that:

- When the OLT receives an upstream frame, the GEM port ID is the only way for the OLT to identify the ONU interface from which the frame is received.
- When a TR-156 ONU receives a downstream frame, the GEM port ID is the only way for the ONU to identify the interface to which the ONU should pass the frame (typically the egress UNI of the ONU).

Although in TR-156 a GEM port will typically refer to a UNI as illustrated in Figure 4-6, it is not excluded that a GEM port refers to a Sub-interface rather than a UNI.

Beyond the strict considerations from TR-156, the following aspects were also taken into account when modelling GEM ports in YANG:

- For the TR-167 case, the virtual UNI depicted see Figure 4-7 rather than a physical UNI is considered when defining GEM port.
- For the case of the IEEE 802.1 MAC Bridging ONU depicted in Figure 4-8, GEM port will be defined in reference to the aggregating ONU-vENET rather than the user-facing UNI.
- In TR-156, when traffic is related to an ONU IP host function, the GEM port can be defined in reference to an ONU-vENET interface, as for example illustrated in Figure 5-3.

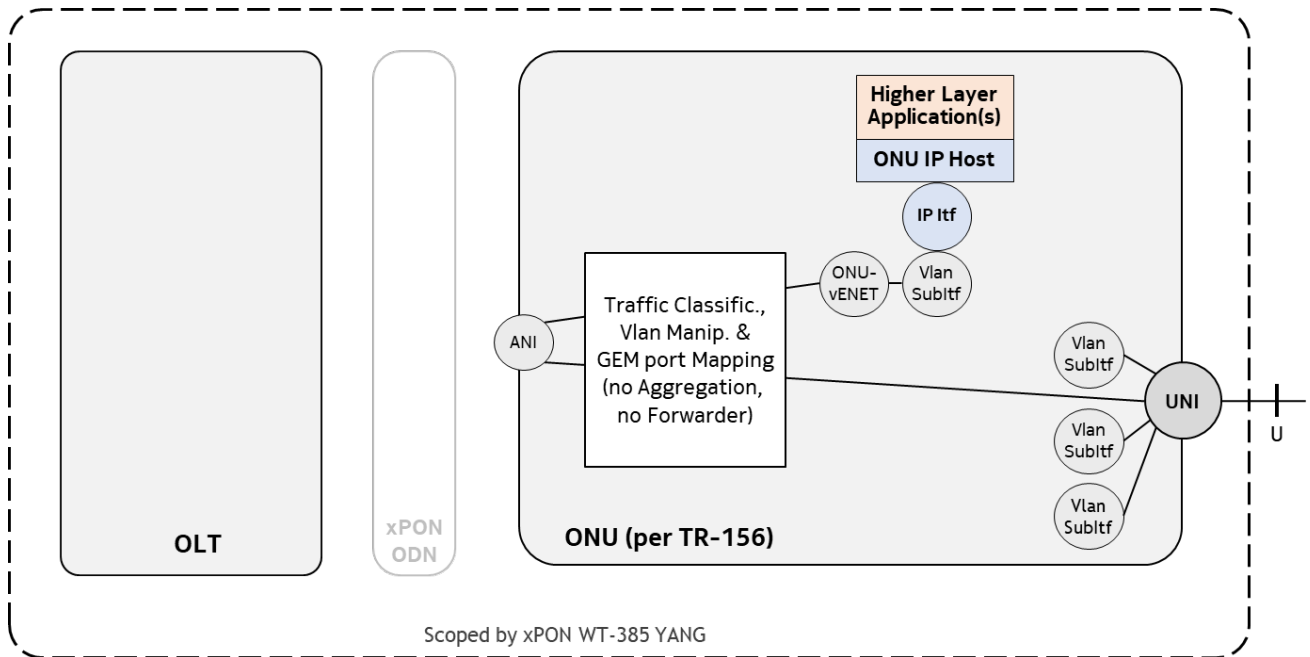

Figure 5-3/13 – GEM ports for a host function in a TR-156 ONU

- In TR-167, when traffic is related to an IP ONU host function, the GEM port can be defined in reference to an ONU-vENET interface, as for example illustrated in Figure 5-4.

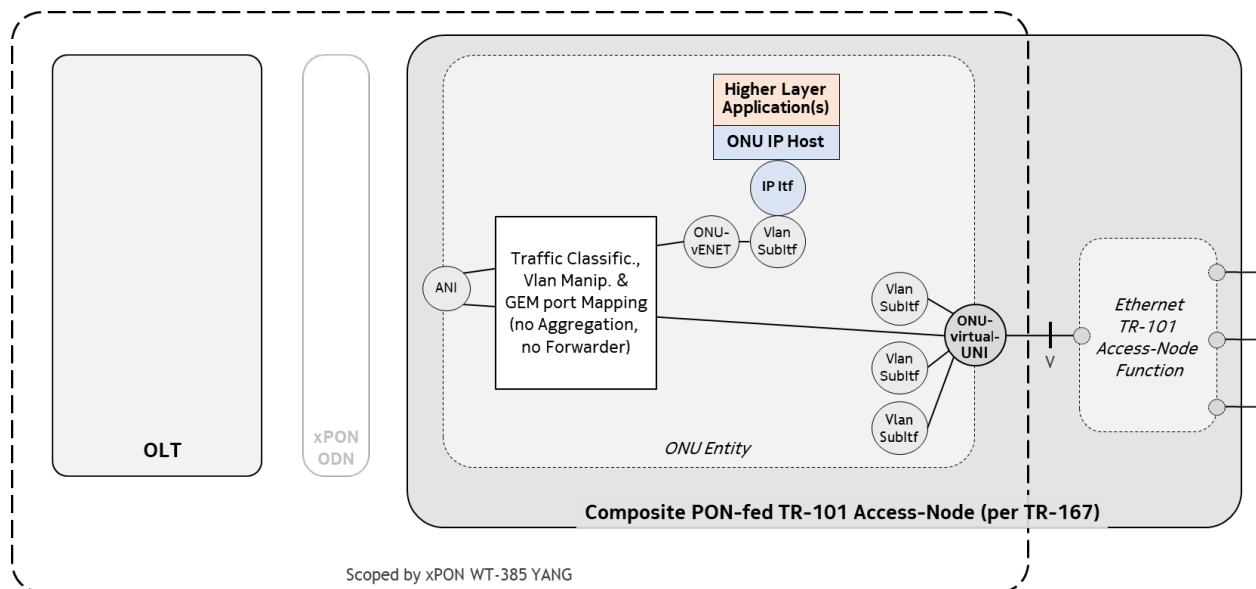

Figure 5-4/14 – GEM ports for a host function in a TR-167 ONU

The OLT and ONU must be aware of GEM ports:

- In combined NE mode, the GEM ports are configured only once in the {OLT-ONUs} YANG instance, on the OLT-vENETs, and then indirectly inherited to the corresponding ONU interfaces by means of the link table.

- In separated mode, the GEM ports are configured in both the {OLT} YANG instance, on the OLT-vENET and the {ONU} YANG instance on the corresponding interfaces.

In general, several OLTs will contribute Channel-Terminations to a given channel group. For proper xPON operation, GEM port IDs must be uniquely allocated on the channel group.

If the YANG feature “configurable-gemport-id” is supported on the device, GEM port IDs can be centrally and individually allocated outside the OLTs by the OAM device layer which configures them to the OLT/ONU xPON YANG model.

If the YANG feature “pon-pools” is supported on the device, the management layer can allocate non-overlapping GEM port IDs to several OLTs belonging to the same channel group.

5.1.5 Model Instantiation

Section 4.1 describes how the xPON YANG model has to support both the Combined-NE mode and the Separated-NE mode as illustrated in Section 4.2 (see Figure 9 and Figure 10). In practice the xPON YANG model is made-up of several YANG modules defined in such a way that:

- If an OLT supports the Combined-NE mode, it announces all xPON YANG modules to its NETCONF Client.
- If an OLT only supports the Separated-NE mode, it announces the subset of xPON YANG modules applicable for managing the OLT to the NETCONF client.
- An ONU operating in a Separated-NE mode will announce the subset of xPON YANG modules applicable for managing the ONU to the NETCONF client.

The list of xPON YANG modules and the applicability matrix for both Combined-NE and Separated-NE modes are detailed in Section 6.

5.1.6 Relationship with Other YANG Modules

The xPON YANG data models defined by this Technical Report cover the building blocks related to the xPON transport functions. Other non-xPON-specific functions in an OLT or an ONU, such as Ethernet services, Sub-Interface management, forwarding functions, control plane functions (e.g., IGMP Snooping, DHCP relay), hardware management and software management, are outside the scope of this document. It is expected that the other data models will be built on, reference, and/or function alongside the ITU-T PON YANG Modules.

The figure below describes the high-level relationship between the xPON YANG modules and other external modules.

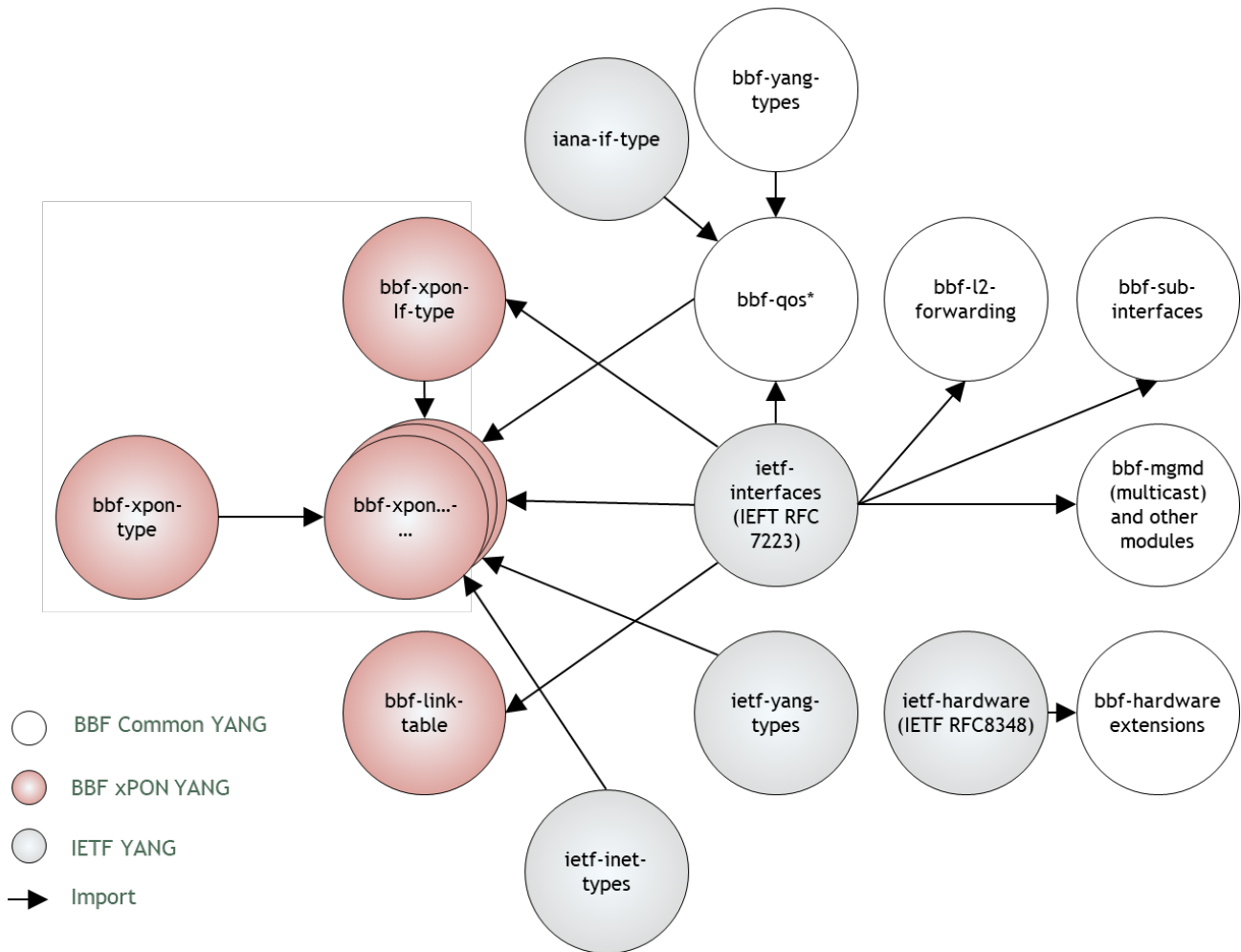

Figure 5-5/Figure 15 – Relationship of xPON YANG Modules with Other Modules

5.1.6.1 TR-383

The ITU-T PON YANG Modules can be used along with the TR-383 to provision the Ethernet services over the PON. TR-383 provides the building blocks for the traffic classification, VLAN manipulation, forwarding and QoS; xPON YANG Modules provides the building blocks to map the resulting traffic class into GEM ports and T-CONTs. Refer to Section 5.2.4 for more details.

5.1.6.2 Interfaces and Hardware Entities Relationships

Figure 5-6 illustrates these relationships from a conceptual point of view.

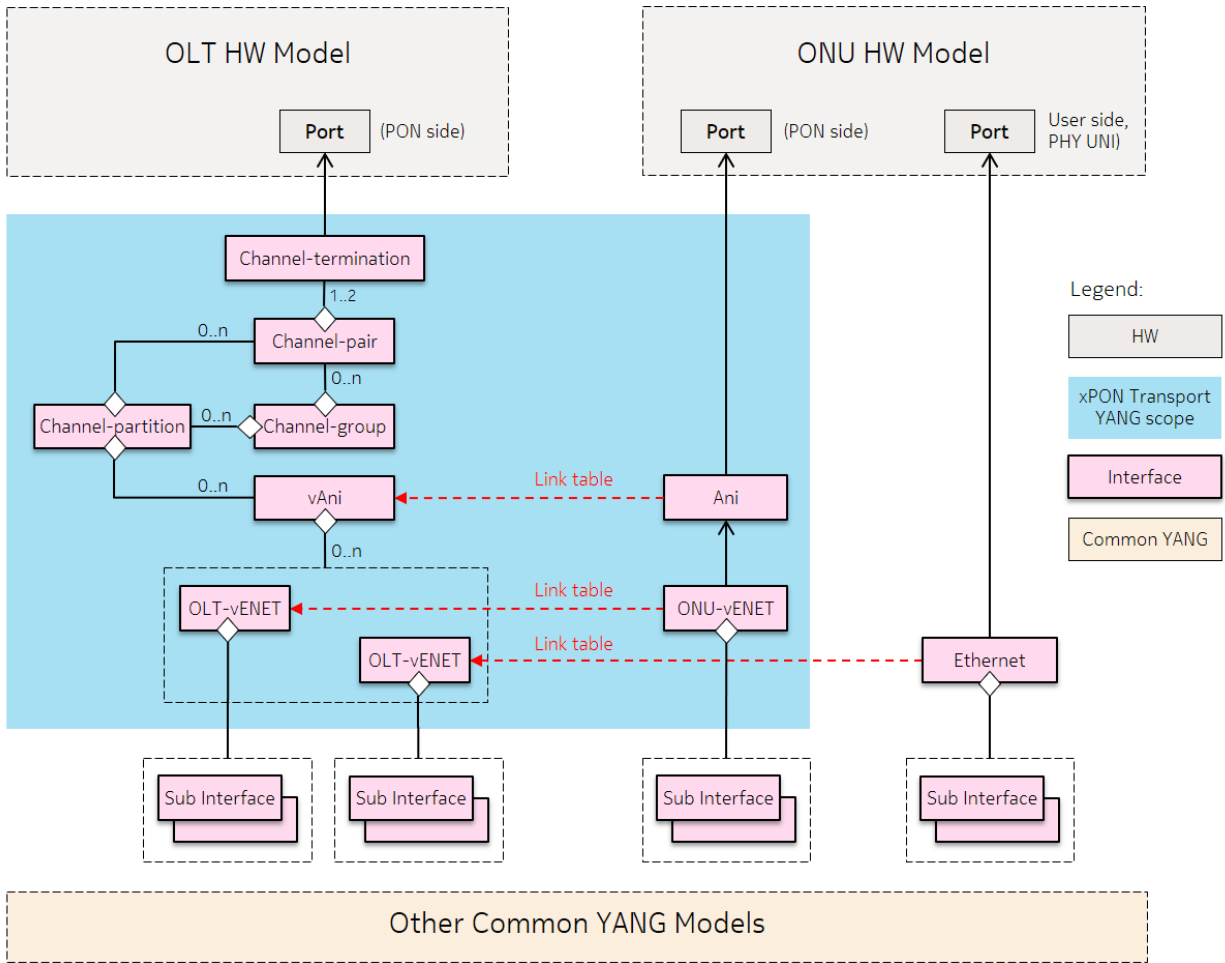

Figure 5-6/Figure 16 - Interfaces and Hardware Entities Relationships

5.2 Basic Operations

This section explains the basic operations using the xPON YANG Modules.

5.2.1 ONU Activation and Authentication

The ONU registration and authentication method is configurable on a channel partition. It needs to be configured prior to the PLOAM message exchanges for the ONU activation and registration.

5.2.2 ONU presence on channel termination

When an ONU is activated many situations are possible in function of different conditions and the type of xPON involved. For instance

- An ONU could be discovered on an OLT without corresponding vANI configured. This is a “show-stopper” for G-PON, XG-PON and XGS-PON but not necessarily so for NG-

PON2 where the ONU could tune to a different wavelength provided by another OLT, duly configured with the ONU's corresponding vANI (more details about ONU Wavelength Mobility are available in section 5.2.7)

- OLTs involved in the same channel-group may have a different view about the same ONU: for instance in NG-PON2, an ONU can only be “present” on *the* OLT serving it.
- Some ONU states apply to all xPON types, but for NG-PON2 the states related to ONU Wavelength Mobility (see section 5.2.7) are not applicable to G-PON, XG-PON nor XGS-PON

Thus, it is important that for each ONU the xPON model maintains state information qualifying the presence of the ONU on a channel termination or indicating that the ONU isn't using any channel termination at the moment.

Similarly, it is also important for the operator to know for each channel termination which ONUs are currently present on the channel termination and in which state.

Finally, it is also desirable that the system can provide YANG notifications when the ONU makes a transition between such states.

For that purpose, the model defines the hierarchical YANG identities below. These identities are defined in detail in “bbf-xpon-onu-types.yang” but for convenience for some of them an informative simplified meaning is provided here in blue:

- onu-presence-state-base
 - onu-present: ONU is using optical signal of a local channel termination
 - onu-present-and-on-intended-channel-termination: ONU is in O5 and there is a matching vANI entry. ONU is ready for provisioning.
 - onu-present-and-in-wavelength-discovery: NG-PON2 ONU is detected, but potentially not using the right wavelength.
 - onu-present-and-discovery-tune-failed: NG-PON2 ONU is not on the intended channel termination and failed to tune where it should.
 - onu-present-and-no-v-ani-known-and-o5-failed: There is no matching vANI entry and ONU couldn't reach O5.
 - onu-present-and-no-v-ani-known-and-o5-failed-no-onu-id
 - onu-present-and-no-v-ani-known-and-o5-failed-undefined
 - onu-present-and-no-v-ani-known-and-in-o5: G-PON, XG-PON or XGS-PON ONU is in O5, but there is no matching vANI entry.
 - onu-present-and-no-v-ani-known-and-unclaimed: NG-PON2 ONU is in O5, locally unknown, and OLT does not know what to do with it because no other OLT is interested in it.
 - onu-present-and-v-ani-known-but-intended-ct-unknown: NG-PON2 ONU is in O5, locally known, but shouldn't be there and OLT does not know what to do with it because no other OLT is interested in it.
 - onu-present-and-v-ani-known-and-o5-failed: Applicable to any xPON type
 - onu-present-and-v-ani-known-and-o5-failed-no-onu-id
 - onu-present-and-v-ani-known-and-o5-failed-undefined
 - onu-present-and-emergency-stopped: ONU is emergency stopped via PLOAM.

- onu-not-present: ONU is not using optical signal of any local channel termination.
 - onu-not-present-with-v-ani: An ONU which is expected to show-up at any time.
 - onu-not present-without-v-ani: An ONU which we didn't know about is now gone.

Figure 5-7 graphically shows the hierarchy of these identities:

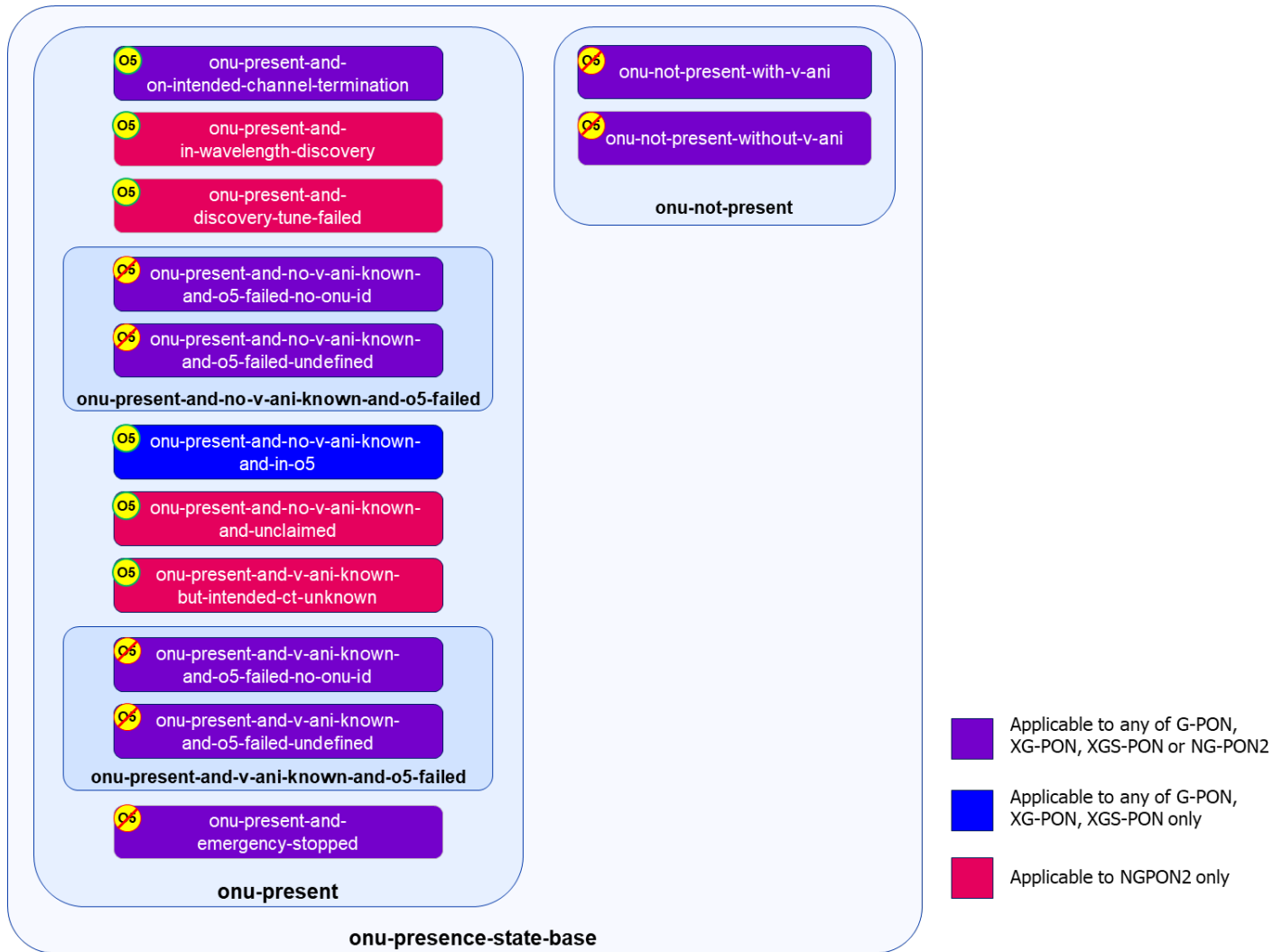

Figure 5-7 – ONU presence states on a channel termination

When reporting the following onu-presence-state values (see “bbf-xponvani-onu-states.yang” module), the most descriptive states should be preferred compared to the more coarse ones in parenthesis:

- (onu-present)
 - onu-present-and-on-intended-channel-termination
 - onu-present-and-in-wavelength-discovery
 - onu-present-and-discovery-tune-fail
 - (onu-present-and-no-v-ani-known-and-o5-failed)

- onu-present-and-no-v-ani-known-and-o5-failed-no-id
 - onu-present-and-no-v-ani-known-and-o5-failed-undefined
- (onu-present-and-v-ani-known-and-o5-failed)
 - onu-present-and-v-ani-known-and-o5-failed-no-onu-id
 - onu-present-and-v-ani-known-and-o5-failed-undefined
- onu-present-and-no-v-ani-known-and-in-o5
- onu-present-and-no-v-ani-known-and-unclaimed
- onu-present-and-v-ani-known-but-intended-ct-unknown
- onu-present-and-emergency-stopped
- (onu-not-present)
 - onu-not-present-with-v-ani
 - onu-not present-without-v-ani

The xPON YANG model makes use of these identities in the following cases:

- For each vANI, an **onu-presence-state** data augment (see “bbf-xponvani-onu-states.yang” module).
- Augment each channel termination with a **list of the ONUs which are present** on the channel termination (list key is ONU serial number), and for which the onu-presence-state value make sense to be reported (see “bbf-xpon-onu-states.yang” module).
- Define a **notification** to signal that a specific ONU has transitioned to some state (see “bbf-xpon-onu-states.yang” module). The reported state can in principle be any one in the onu-presence-state list, but the OLT must be configured with a list of states for which it should generate a notification.

An operator might be interested only in a subset of possible ONU presence states, depending on the specific deployment requirements. WT-385 provides the ability to select which ONU presence states should be reported as YANG notifications. It is achieved by adding elements in “notifiable-onu-presence-states” list defined in “bbf-xpon-onu-state.yang” model, configurable per channel termination. Each element in “notifiable-onu-presence-states” is the state that should be reported when transitioned into. The “notifiable-onu-presence-states” is empty by default, meaning that no “onu-presence-state-change” notifications are sent. “If “notifiable-onu-presence-states” includes an identity which is the base value for other presence state(s) identity(ies), the OLT will generate a single notification if it detects that an ONU undergoes a transition into the configured presence state, directly or indirectly via one of its derived presence states. For example, if “notifiable-onu-presence-states” list includes the identity “onu-present-and-v-ani-known-and-o5-failed” and the OLT detects that an ONU undergoes a transition into “onu-present-and-v-ani-known-and-o5-failed-no-onu-id”, the OLT will generate a single notification reporting the ONU transition into “onu-present-and-v-ani-known-and-o5-failed-no-onu-id”.

5.2.3 T-CONT, QoS and GEM Association

This section explains how GEM ports and T-CONTs relate to QoS when TR-385 is used in association with TR-383.

Each T-CONT includes a reference to a traffic descriptor profile instance for DBA, a tm-root instance that defines scheduler and queues inside that T-CONT, and a reference to a vANI interface

(i.e., the ONU). Each GEM port includes Reference to an OLT-vENET interface or a sub-interface, a traffic class, and a reference to a T-CONT. A GEM port is mapped to a T-CONT queue according to the traffic class to queue id mapping profile configuration.

Figure 5-8 illustrates the T-CONT scheduling, queueing and GEM association configuration by using both the ITU-T PON YANG Modules and the QoS Module.

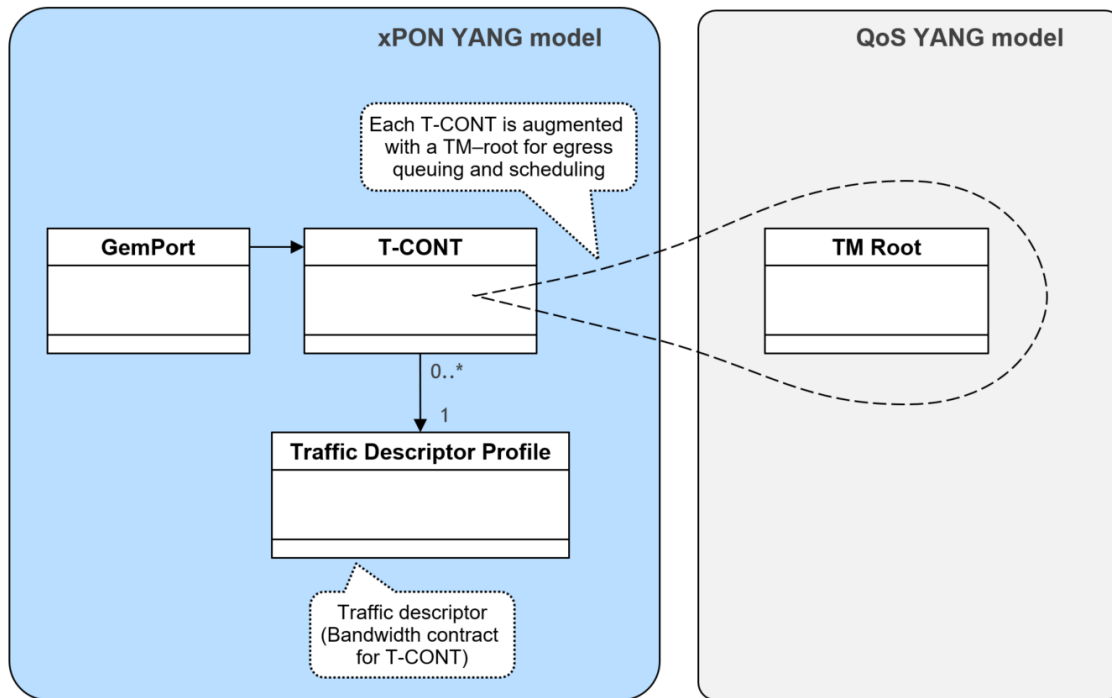

Figure 5-8/Figure 17 – ONU T-CONT Scheduling, Queueing and GEM Association

5.2.4 Ethernet Service Configuration

The ITU-T PON YANG Modules can be used along with the TR-383 to provision the Ethernet services over the PON, independent of the exact nature of the UNI (e.g., Ethernet, xDSL, FAST).

The complementarity between xPON and TR-383 is shown in Figure 5-9, Figure 5-10 and Figure 5-11. They show the OLT and the ONU both broken logically into two parts: xPON-specific entity and non-PON-specific entity. TR-383 configures the traffic classification and forwarding, while the ITU-T PON YANG Modules cover the xPON adaptation functionality, irrespective of the device and user interface type (for instance the GEM adaptation function mapping Ethernet over xPON).

As shown in the next sub-sections, TR-383 and the ITU-T PON YANG Modules can be used in various combinations to achieve different connectivity patterns.

5.2.4.1 xPON Model applied to TR-156

In case of TR-156, ONUs effectively do not rely on forwarders and forwarder ports defined in TR-383 to handle traffic. Instead, TR-156 ONUs handle traffic as follows:

- In the upstream direction, the ONU only needs to perform the xPON adaptation function, i.e., map the traffic into a GEM port based on the UNI interface (or the sub-interface) and the traffic class. T-CONT selection and traffic scheduling to the T-CONT queues is determined by GEM ports.
- In the downstream direction, the ONU maps the traffic from a GEM port directly to a UNI port. Traffic scheduling to the UNI queues is determined by the frame traffic class derived from the GEM port.

Hence for the case of TR-156, we can use the simple model depicted in Figure 5-9. In this simplified model, there is a direct 1:1 relation between each physical UNI on the ONU user side and a corresponding OLT-vENET on the OLT by means of the link table.

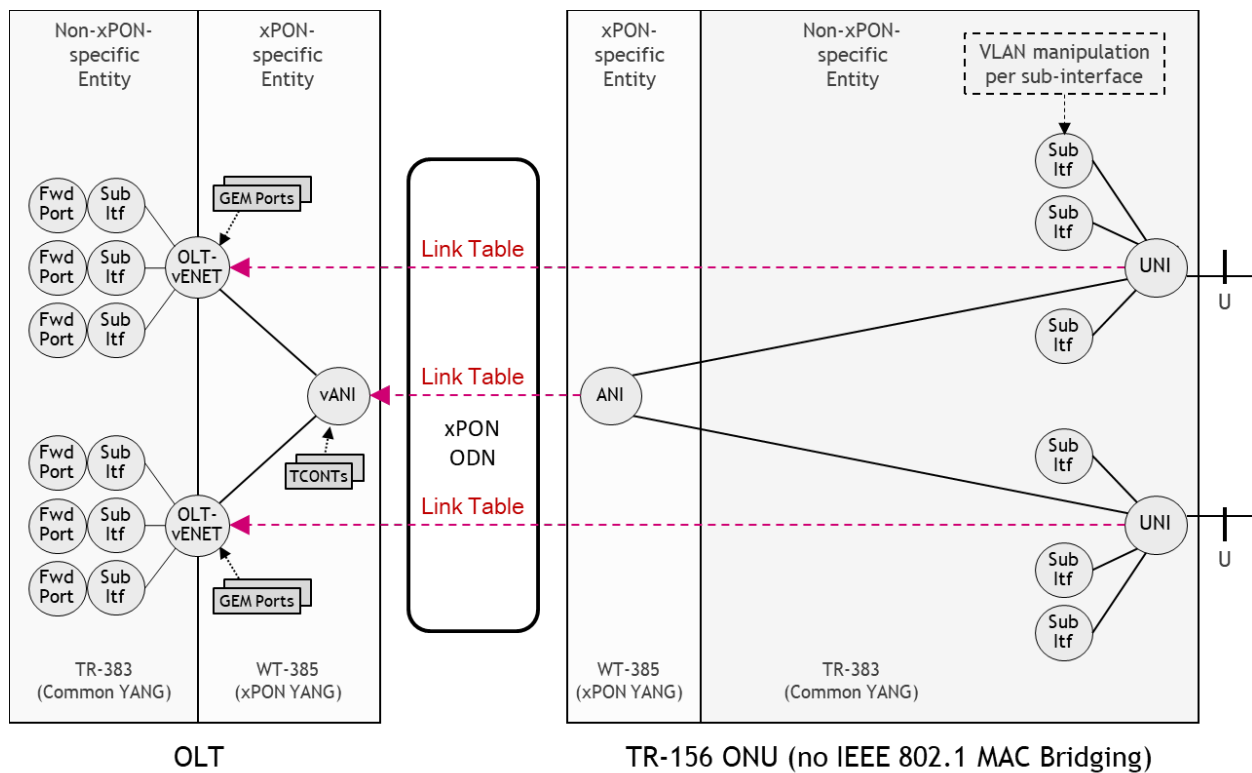

Figure 5-9/Figure 18 - Ethernet Service Model Example for TR-156 Application

5.2.4.2 xPON Model applied to TR-142, TR-167 and TR-301

A TR-142 device embeds the ONU and Residential Gateway functions in a single physical device. In this case, the ITU-T PON YANG Modules are used for the configuration and management of the xPON specific entity of the ONU entity, and TR-383 can be used for the management of the non-

xPON specific entity of the ONU entity. The Residential Gateway functions are configured and managed by either TR-069, or other protocols. The (*) in Figure 5-10 corresponds to the “virtual UNI” U reference point in TR-142.

A TR-167 device embeds the ONU and TR-101 access node in a single physical device. In this case also, the ITU-T PON YANG Modules are used for the configuration and management of the xPON specific entity of the ONU entity, and TR-383 can be used for the management of the non-xPON specific entity of the ONU entity. The Ethernet access node functions are configured and managed by either NETCONF, or other protocols. The (*) in Figure 5-10 corresponds to the V reference point in TR-167¹.

A TR-301 DPU [20] with the xPON-based backhaul may operate in either Model 1 (TR-167 backhaul) or Model 2 (TR-156 backhaul) deployments. In Model 2, there may be more than one virtual Ethernet interfaces between the Backhaul and the Port Frame Forwarding Function (PFFF). In both models, the ITU-T PON YANG Modules may be used for the configuration and management of the xPON adaptation functions in the Backhaul entity. The (*) in Figure 5-10 corresponds to the virtual Ethernet interface between the Backhaul and the PFFF.

As already stated earlier, from an xPON YANG model point of view, all these cases boil down to TR-156 where the UNI is replaced by a virtual UNI interface.

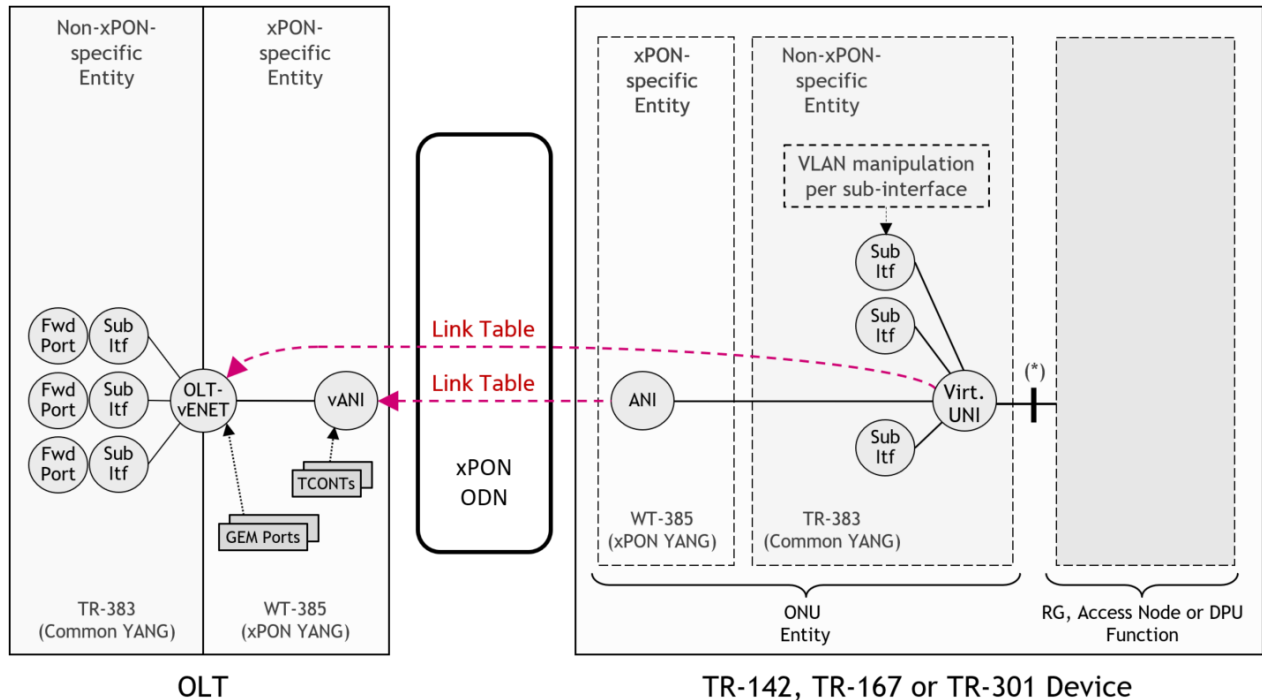

Figure 5-10/Figure 19 - Ethernet Service Model Example for TR-142, TR-167 and TR-301 Applications

¹ TR-167 does not preclude more than one interface between an ONU entity and an access node, however this is not typical.

5.2.4.3 xPON Model applied to IEEE 802.1 MAC Bridging ONU

Figure 5-11 shows the general case of the Ethernet service configuration model for the IEEE 802.1 MAC Bridging ONU introduced in Section 4 in Figure 4-5 and Figure 4-8.

Considering the upstream direction, such ONU performs IEEE 802.1 MAC Bridging between several User (U) interfaces to one or several ONU-vENET Uplink interfaces.

More precisely, on U interface ingress, frames are first classified at the ingress sub-interfaces and forwarded by forwarders and their forwarder ports to egress sub-interfaces on the ONU-vENET interface (and conversely in downstream).

Per TR-383, VLAN manipulations are performed on the ingress or egress sub-interfaces and forwarders can be used to handle 1:1 VLAN and N:1 VLAN applications per TR-101.

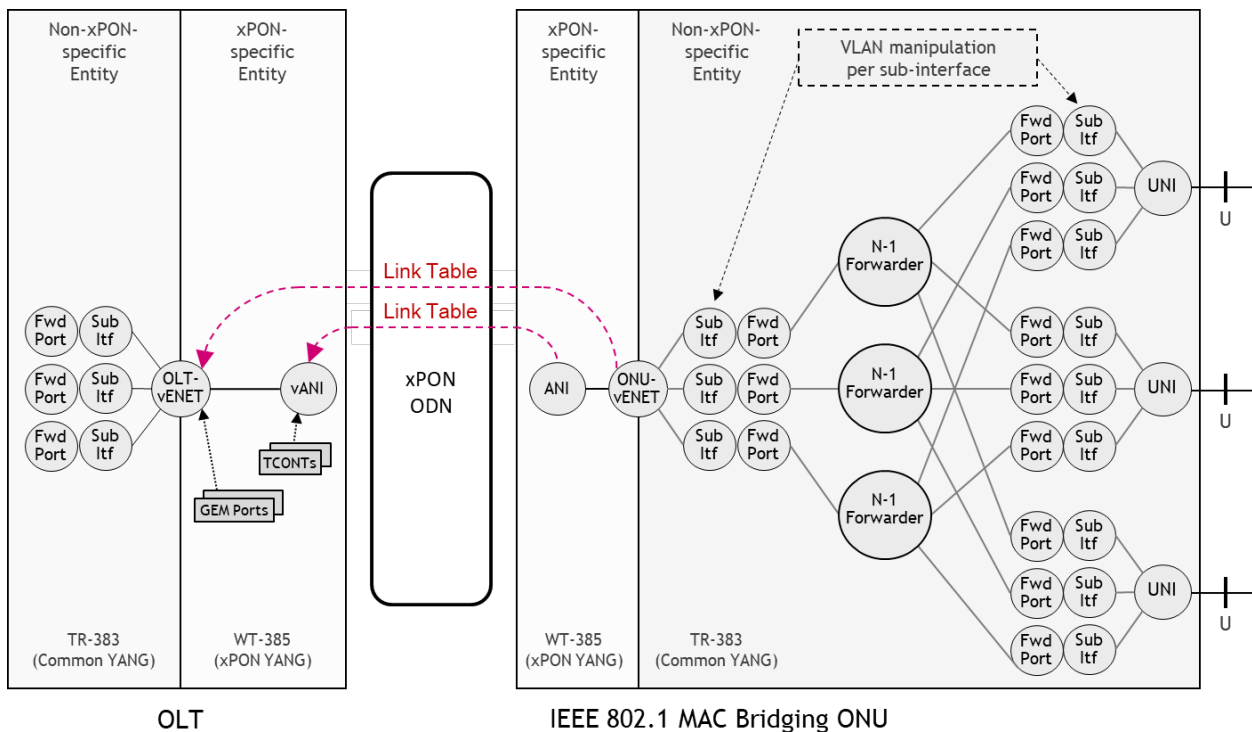

Figure 5-11/Figure 20 - Ethernet Service Model Example for IEEE 802.1 MAC Bridging ONU

5.2.5 Upstream and downstream QoS

Figure 5-12 presents an example model of upstream traffic management from TR-156. At the ONU level, upstream traffic received from U interfaces is mapped to T-CONT queues as described in Section 5.2.2. At the OLT level, a tm-root instance is configured for the schedulers and queues of the network facing port. Traffic from various T-CONTs and PON interfaces is mapped into appropriate queues of that network facing port.

Upstream scheduling at SNI interface

Upstream scheduling at ONU

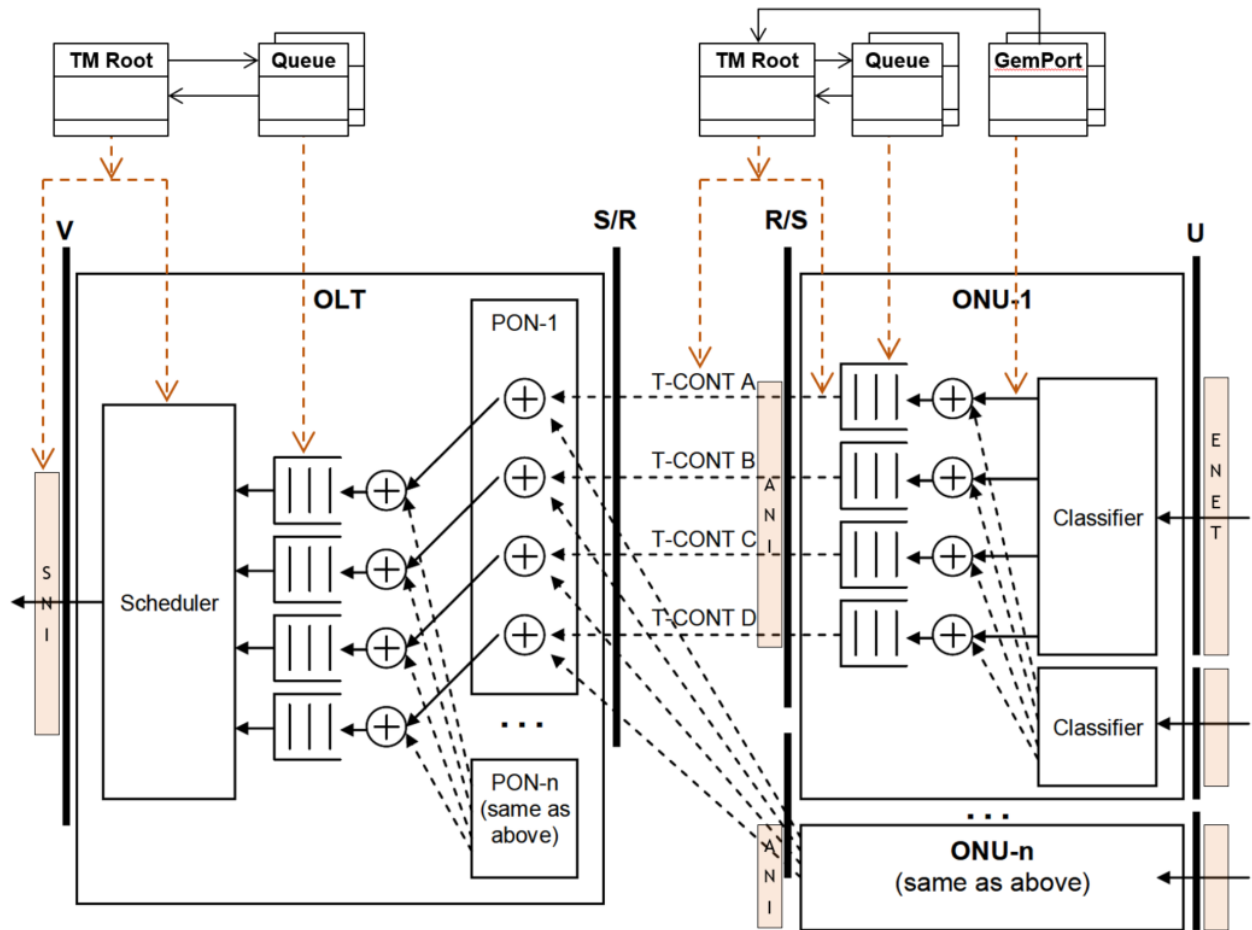

Figure 5-12/Figure 21 – Upstream Scheduling and Queuing Model Example

Figure 5-13 presents an example model of downstream traffic management from TR-156. At the OLT level, a tm-root instance is configured for the schedulers and queues of the PON interface, a classifier (e.g., bbf-qos-classifiers) defines the traffic class assignment for traffic flows, and traffic is then placed into queues to be scheduled and transmitted downstream to the PON interface. At the ONU level, a tm-root instance is configured for the schedulers and queues of each U interface. The ONU maps traffic to queues according to GEM port, and each GEM port is associated with a single queue according to the traffic class.

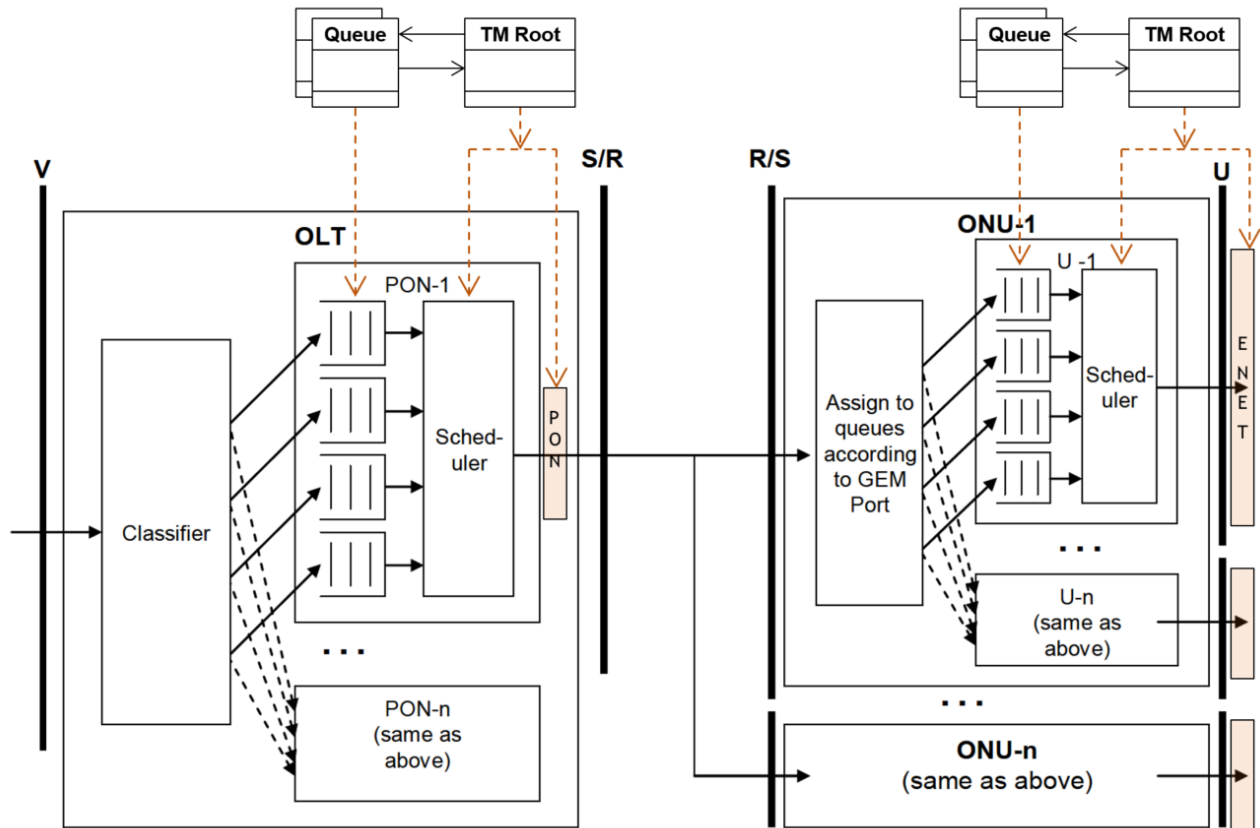

Figure 5-13/Figure 22 – Downstream Scheduling and Queuing Model Example

5.2.6 Type B protection

As illustrated in Figure 5-14, the xPON YANG model offers the possibility of type B protection per channel pair.

In the model, a channel pair can be associated with up to two channel terminations. When both channel terminations are configured on the channel pair, the channel pair is 1:1 Type B protected (refer to G.989.3 Amendment 1, Clause 18.2 [14]). Each channel termination of a protected channel pair is configured with the default role of either Primary or Secondary. The operational state data of a channel termination includes the active/standby protection state.

There is no Type B protection when the channel pair is associated with only one channel termination.

The same configuration is applicable to G-PON, XG-PON, XGS-PON, and NG-PON2.

Please note that Figure 5-14 provides a didactic but simplified and approximate view compared to the UML automatically generated from the actual YANG modules.

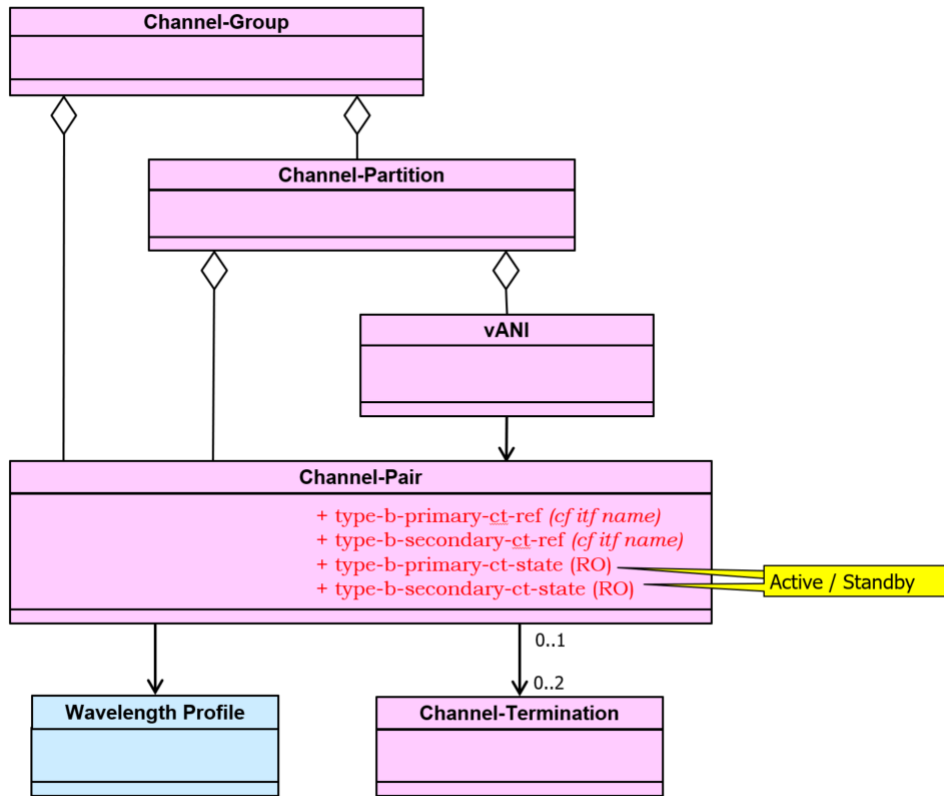

Figure 5-14/Figure 23 – Support for Type B Protection

5.2.7 ONU Wavelength Mobility

5.2.7.1 Introduction

Although an ONU (actually a vANI) is configured on a channel partition rather than on a specific channel pair (refer to Section 5.1.1), ultimately at any point in time the ONU gets its connectivity service through a single channel pair from the channel partition.

When there are several channel pairs available in the channel partitions - typical in NG-PON2 – selecting and enforcing which channel pair will effectively be used by each ONU at any point in time is referred to as “ONU Wavelength Mobility”.

There are a lot of operational use cases associated to ONU WL Mobility (for example, refer to ITU-T G.989.3, Appendix VI and BBF TR-352 [22]) in which the OAM device layer needs to control which channel pair an ONU is supposed to use when activated and at any point in time while in service.

ONU WL Mobility applies to the following situations:

- Determine and make sure that an ONU is activated on the intended channel pair
- Provide the possibility that an ONU changes of channel pair while in service

- Provide the possibility that an ONU autonomously falls back on a predefined protection channel pair in case of failure of the channel pair it currently uses (this last case is referred to as “ONU WL protection”)

As illustrated in Figure 5-15 and the next sections, the xPON YANG model provides means to support each of the ONU Mobility situations above. It also contains state leaves about the ONU tuning status, for instance on which channel pair and channel termination the ONU is tuned (in case it is).

Please note that Figure 5-15 provides a didactic but simplified and approximate view compared to the UML automatically generated from the actual YANG modules.

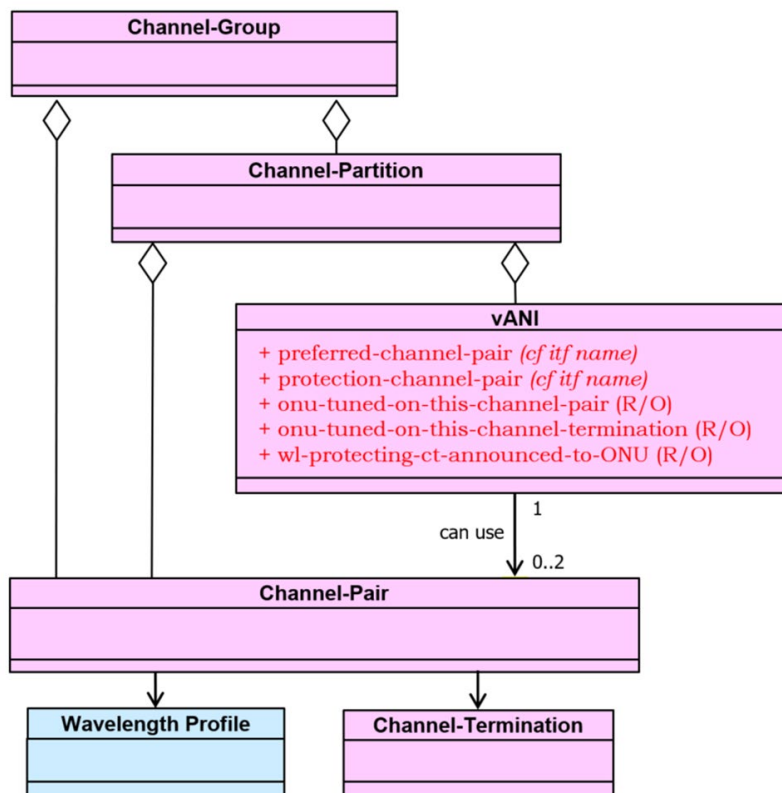

Figure 5-15/Figure 24 – Support for ONU WL Mobility

5.2.7.2 Controlling the Channel-pair to be used by an ONU at activation time

In the Model, each vANI is configured with a “preferred channel pair”.

The “preferred channel pair” configured on the vANI refers to the channel pair that an activating ONU is intended to use. If the preferred-channel pair interface is not available, the ONU should use the protection channel pair (see Section 5.2.7.4) if it is provisioned and available. Modification of the preferred channel pair has no effect on the ONU when it is activated (e.g., reconfiguration of the preferred channel pair will not cause an activated ONU to retune its receiver).

5.2.7.3 Controlling the Channel-pair used by an ONU during service

To make an ONU change channel pair while in service, the OAM Device layer will issue a specific NETCONF YANG v-ANI related ACTION to the OLT which will lead the associated ONU to retune to the channel pair indicated in the ACTION.

5.2.7.4 ONU Wavelength Protection

The Model also gives the possibility to configure a “protection channel pair” on each vANI. It can be used during ONU activation or during ONU service as detailed below.

The “protection channel pair” configured on the vANI refers to the channel pair that an activating ONU is intended to use if the preferred channel pair is not available.

Also, when the ONU is having service on a given current channel pair, the protection channel pair is also the channel pair that the ONU will autonomously tune to if the current channel pair becomes not available.

Modification of the protection channel pair has no effect on the ONU when it is activated (e.g., reconfiguration of the protection channel pair will not cause an activated ONU to retune its receiver).

In its state data, the model indicates which WL protecting channel termination has been announced to the ONU (in case the ONU is effectively WL protected).

5.2.7.5 Support for ICTP

ONU Wavelength Mobility relies for its operation on ICTP (Inter Channel-Termination Protocol) which has been standardized in TR-352.

The xPON YANG model provides support for ICTP and its transport infrastructure in full compliance with TR-352, as a specific “ictp-support” YANG feature.

At a high level, TR-352 addresses a standard way for channel terminations to interact with each other for cross-OLT features. It should be noted that ICTP is applicable to all xPON variants since it has also other applications than ONU WL mobility typical of NG-PON2. TR-352 provides:

- A reference network architecture clarifying the applicability and responsibilities of ICTP.
- Applicable Uses Cases.
- A set of ICTP messages and parameters exchanged between channel terminations.
- High level UC analysis and related ICTP procedures.
- Top level State Machines and several detailed example scenarios (e.g., ONU activation and WL mobility).

Figure 5-16 illustrates the reference architecture defined in TR-352 for the support of ICTP.

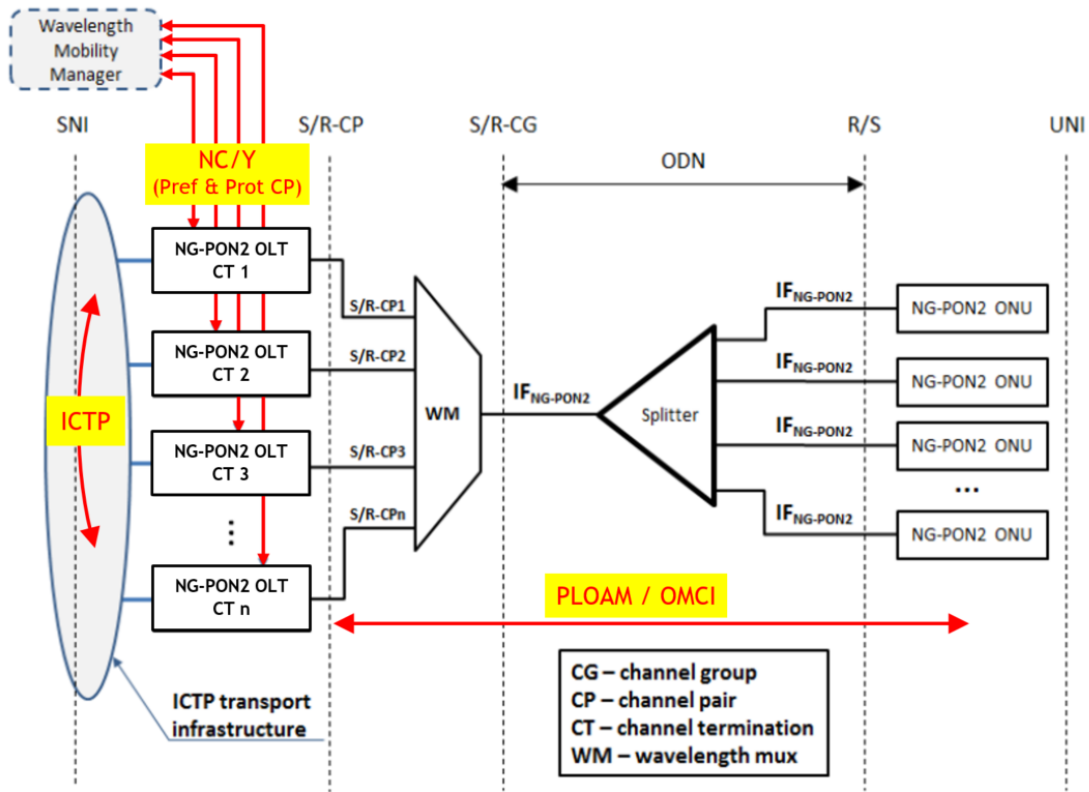

Figure 5-16/Figure 25 – Reference Architecture of an NG-PON2 system [from TR-352]

ICTP has the following features:

- ICTP messages are point-to-point transported from channel termination-to-channel termination through TCP connections.
- For scalability reasons, TCP connections are established between “ICTP proxies” rather than directly between individual CTs. From TR-352:
*“4.5.2 ICTP Proxy
 ICTP proxy provides an interface between the ICTP layer and the ICTP transport infrastructure protocol suite. One ICTP proxy hosts one or more CTs within an OLT NE. The CTs hosted by an ICTP proxy may belong to the same NG-PON2 system or to different NG-PON2 systems. An OLT NE may have one or more ICTP proxy instances.”*
- An OLT can contain one or several ICTP proxies, each one in charge of one or several channel terminations.
- The number of ICTP proxies in a given OLT and which channel termination(s) they take care of is left to OLT vendors’ discretion.

An example of interconnection pattern between channel terminations is provided in Figure 5-17, assuming a channel group containing 8 channel terminations over 3 OLTs, say 4 primary channel terminations and 4 secondary channel terminations for type B protection:

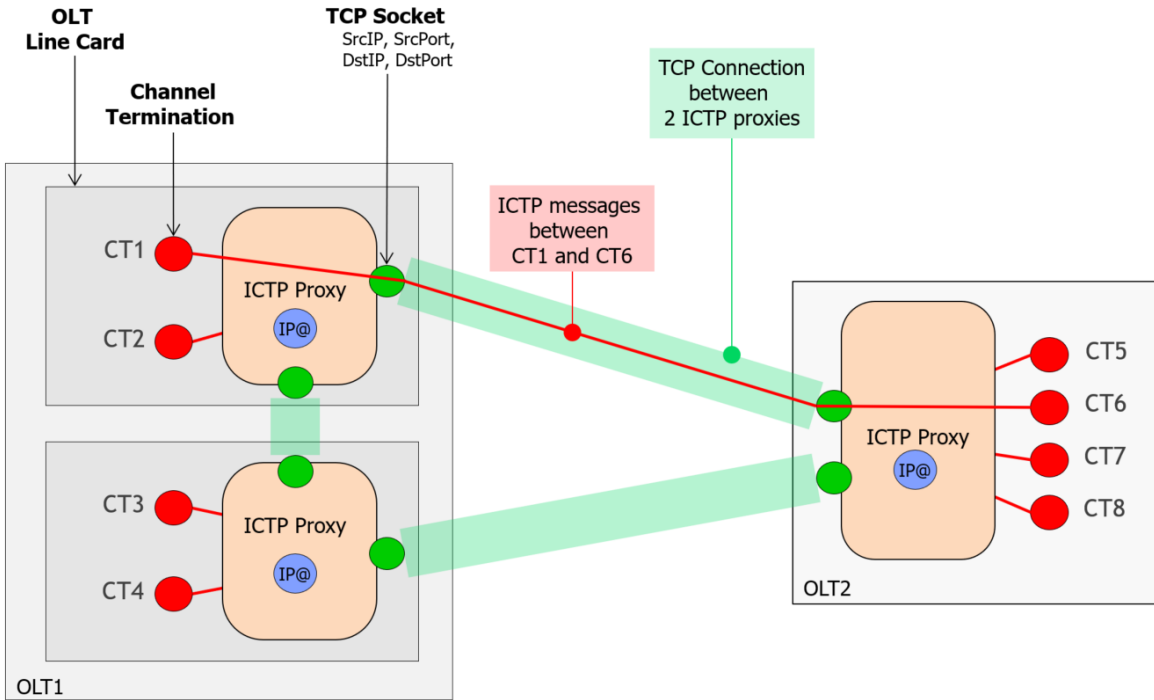

Figure 5-17/Figure 26 – An example of ICTP Interconnection Pattern

For systems that implement the “ictp-support” YANG feature, the xPON YANG model supports in a flexible way the requirements mandated by TR-352 for the ICTP transport infrastructure. Figure 5-18 provides an illustration. Please note that this figure provides a didactic but simplified and approximate view compared to the UML automatically generated from the actual YANG modules.

In the model, for all channel groups configured, the OLT is configured with all the ICTP proxies involved. This includes also the proxies caring for channel terminations “outside” the OLTs (refer to “All-Ictp-Proxies-All-Channel-Groups” in Figure 5-18). For instance, in another example in Figure 5-19, the YANG model of each OLT is configured with “ICTP proxy A”, “ICTP proxy B”, and “ICTP proxy C”.

Then, for each ICTP proxy, the OLT is configured with the list of all channel terminations that the proxy can transmit and receive ICTP messages on behalf of (refer to “All-Ct-Proxied-By-This-Proxy” in Figure 5-18). This includes the channel terminations “inside” and “outside” the OLT. For instance, in Figure 27, the YANG model of each OLT is configured with:

- Channel-termination-1 and -2 being proxied by “ICTP proxy A”
- Channel-termination-3 and -4 being proxied by “ICTP proxy B”
- Channel-termination-5 and -6 being proxied by “ICTP proxy C”

Finally, the OLT maintains state information about Proxy-to-Proxy peering relations.

For that purpose, the model maintains a list of ICTP proxies containing state data about peering relations from this ICTP proxy to one or several other ICTP proxies. An OLT must know at least all peering relations involving all those ICTP proxies which are in charge of one or several channel

terminations 'inside' the OLT; an OLT may or may not know peering relations between ICTP proxies exclusively involving channel terminations 'outside' the OLT (refer to “Known-Peered-Proxies” in Figure 5-18). For instance, in Figure 5-19, OLT1 must know all peering relations involving “ICTP Proxy A” but is not mandated to be aware of the peering relation between “ICTP Proxy B” and “ICTP Proxy C”.

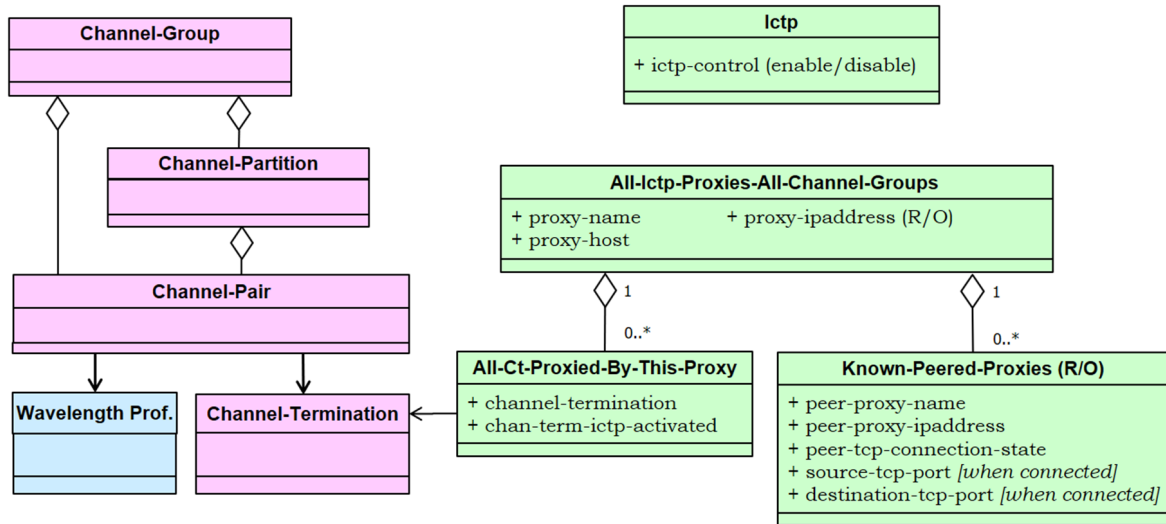

Figure 5-18/Figure 27 – Support of ICTP by xPON YANG model

Figure 5-19 illustrates a detailed instantiation of the xPON YANG model for ICTP in case of another ICTP interconnection pattern.

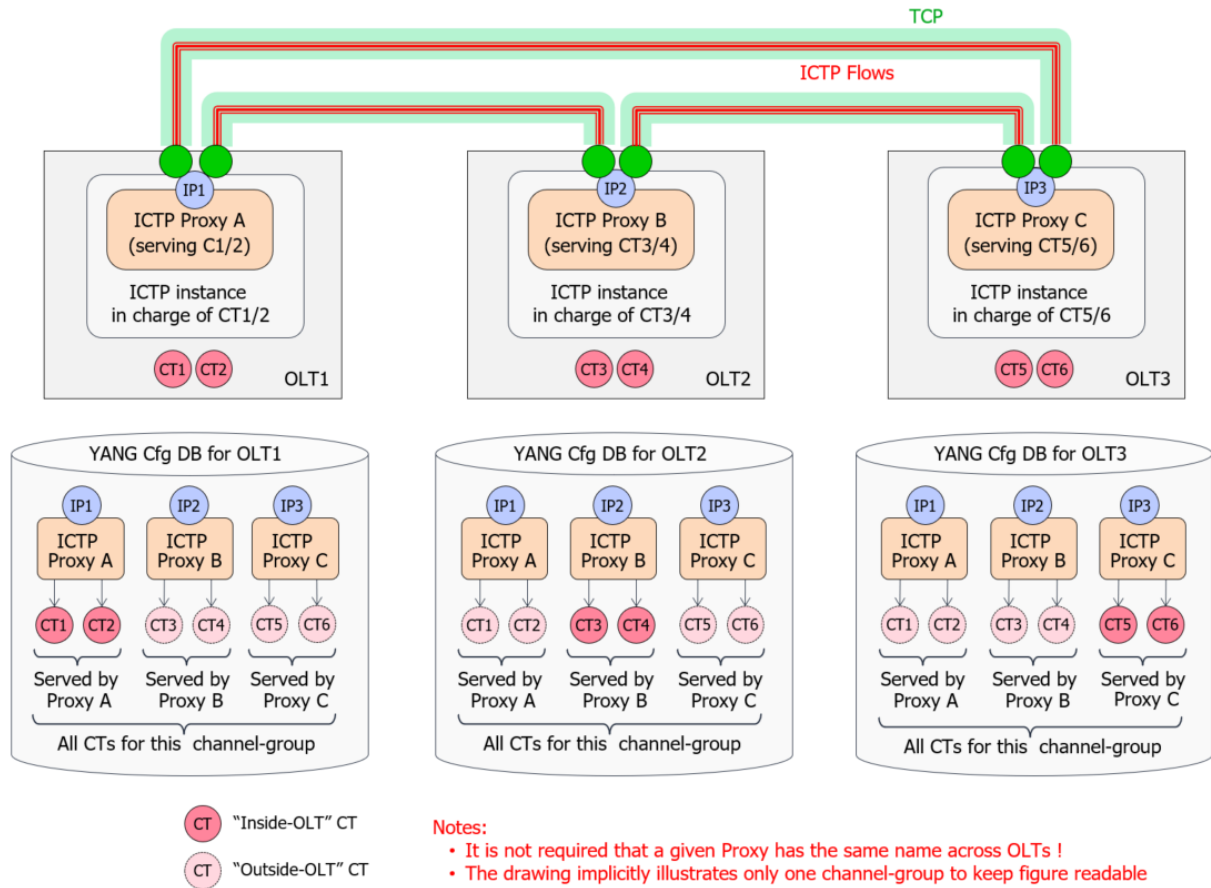

Figure 5-19/Figure 28 – A detailed example of xPON YANG model instantiation for ICTP

6 Modules

The YANG modules contained in TR-385 are briefly described here.

6.1 General UML Model

Figure 6-1 provides a view of some important objects of the xPON YANG model and how they conceptually interrelate with each-others.

Please note that this drawing provides a didactic but simplified and approximate view compared to the UML automatically generated from the actual YANG modules.

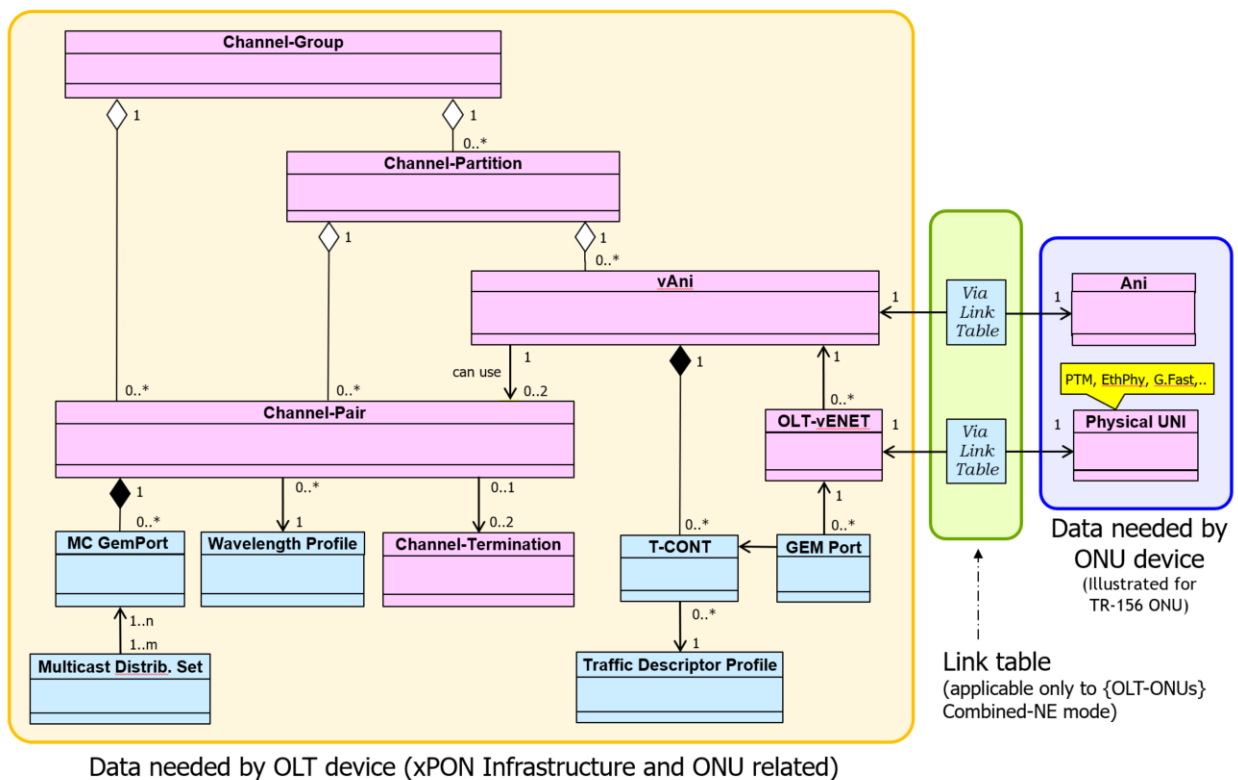

Figure 6-1/Figure 29 – xPON YANG UML Model

6.2 xPON Modules and Sub-modules

The xPON YANG model consists in the generic set of Modules and Submodules listed in Section 6.2.1.

With these (sub)modules it is possible to support each of the cases described earlier in this document:

- {OLT-ONUs} Combined-NE,
- {OLT} Separated-NE and
- {ONU} Separated-NE

Each of these cases can be supported by selecting the appropriate subset of YANG modules which the NE needs to support and announce to its NETCONF Client; see respective Sections 6.2.2, 6.2.3, and 6.2.4.

6.2.1 Generic set of xPON Modules and Submodules

Below is an overview of each modules and submodules. The next sections briefly describe the scope and contents of each module.

- Module bbf-xpon-types.yang
- Module bbf-xpon-if-type.yang
- Module bbf-xpon.yang
 - Submodule bbf-xpon-base.yang
 - Submodule bbf-xpon-wavelength-profile-body.yang
 - Submodule bbf-xpon-multicast-gemport-body.yang
 - Submodule bbf-xpon-channel-group-body.yang
 - Submodule bbf-xpon-channel-partition-body.yang
 - Submodule bbf-xpon-channel-pair-body.yang
 - Submodule bbf-xpon-channel-termination-body.yang
 - Submodule bbf-xpon-multicast-distribution-set-body.yang
- Module bbf-xponvani.yang
 - Submodule bbf-xponvani-base.yang
 - Submodule bbf-xponvani-v-ani-body.yang
 - Submodule bbf-xponvani-v-enet-body.yang
- Module bbf-xpongemtcont.yang
 - Submodule bbf-xpongemtcont-base.yang
 - Submodule bbf-xpongemtcont-traffic-descriptor-profile-body.yang
 - Submodule bbf-xpongemtcont-tcont-body.yang
 - Submodule bbf-xpongemtcont-gemport-body.yang
- Module bbf-xpongemtcont-qos.yang
- Module bbf-link-table.yang
- Module bbf-xponani.yang
 - Submodule bbf-xponani-base.yang
 - Submodule bbf-xponani-ani-body.yang
 - Submodule bbf-xponani-v-enet-body.yang
- Module bbf-xpon-onu-state.yang

- Module `bbf-xpon-onu-types.yang`
- Module `bbf-xpon-performance-management.yang`
- Module `bbf-xpon-power-management.yang`
- Module `bbf-xponani-power-management.yang`
- Module `bbf-xponvni-power-management.yang`
- Module `bbf-xpongemtcont-gemport-performance-management.yang`
- Module `bbf-xpon-defects.yang`
- Module `bbf-hardware-transceivers-xpon.yang`

6.2.1.1 Module `bbf-xpon-types`

This module contains a collection of YANG definitions which defines common YANG types used in the management of xPON.

6.2.1.2 Module `bbf-xpon-if-type`

This module contains a collection of YANG definitions which defines xPON interface types that are needed for Broadband Forum applications but are not defined by IANA.

6.2.1.3 Module `bbf-xpon`

This module contains a collection of YANG definitions for supporting the Broadband Forum requirements on management of ITU-T Passive Optical Network (PON) interfaces as defined in ITU-T G.984.x, G.987.x, ITU-T G.989.x and ITU-T G.9807.x.

6.2.1.3.1 Submodule `bbf-xpon-base`

This submodule contains a collection of YANG definitions and augmentations to `ietf-interfaces` [5] for managing the xPON infrastructure.

6.2.1.3.2 Submodule `bbf-xpon-channel-group-body`

This submodule contains a collection of YANG definitions for managing channel groups.

6.2.1.3.3 Submodule `bbf-xpon-channel-partition-body`

This submodule contains a collection of YANG definitions for managing channel partitions.

6.2.1.3.4 Submodule `bbf-xpon-channel-pair-body`

This submodule contains a collection of YANG definitions for managing channel pairs.

6.2.1.3.5 Submodule bbf-xpon-channel-termination-body

This submodule contains a collection of YANG definitions for managing channel terminations.

6.2.1.3.6 Submodule bbf-xpon-multicast-distribution-set-body

This submodule contains a collection of YANG definitions for managing multicast distribution sets.

6.2.1.3.7 Submodule bbf-xpon-multicast-gemport-body

This submodule contains a collection of YANG definitions for managing multicast GEM ports.

6.2.1.3.8 Submodule bbf-xpon-wavelength-profile-body

This submodule contains a collection of YANG definitions for managing wavelength profiles.

6.2.1.4 Module bbf-xponvani

This module contains a collection of YANG definitions for managing the virtual representation of the Access Network Interfaces (vANI) of the ONU.

6.2.1.4.1 Submodule bbf-xponvani-base

This submodule contains a collection of YANG definitions and augmentations to ietf-interfaces [5] managing in xPON the virtual ONUs in the OLT.

6.2.1.4.2 Submodule bbf-xponvani-v-ani-body

This submodule contains the data for managing the virtual Access Network Interface (vANI). A vANI belongs to the OLT and represents an ONU as seen from the perspective of the OLT.

6.2.1.4.3 Submodule bbf-xponvani-v-enet-body

This submodule contains data related to virtual Ethernet interfaces belonging to the virtual ONU at the OLT, such as the olt-v-enet interface.

6.2.1.5 Module bbf-xpongemtcont

This module contains a collection of YANG definitions for managing of G-PON Encapsulation Method (GEM) ports, Transmission Containers (T-CONT) and traffic descriptors.

6.2.1.5.1 Submodule bbf-xpongemtcont-base

This submodule contains a collection of YANG definitions for managing top level xPON GEM port and T-CONT configuration and state data.

6.2.1.5.2 Submodule **bbf-xpongemtcont-gemport-body**

This submodule contains a collection of YANG definitions for managing G-PON Encapsulation Method (GEM) ports.

6.2.1.5.3 Submodule **bbf-xpongemtcont-tcont-body**

This submodule contains a collection of YANG definitions for managing Transmission Containers (T-CONT).

6.2.1.5.4 Submodule **bbf-xpongemtcont-traffic-descriptor-profile-body**

This submodule contains a collection of YANG definitions for managing traffic descriptor profiles.

6.2.1.6 Module **bbf-link-table**

This module defines a generic link table providing linkage between interfaces.

For the purpose of the xPON model, this module is only applicable to the {OLT-ONUs} Combined-NE management mode. It is intended to establish horizontal link relations between counterpart interfaces on the OLT and the ONU, by means of which the querying interface can inherit some parameters from the queried interface.

In the link table, the “itf-from” field defines the querying interface (e.g., ANI), the “itf-to” defines the queried interface (e.g., the vANI).

Below the list for xPON of which interface is eligible as querying interface and which corresponding interface can be queried. No other interface than those listed below should be configured as querying interface for xPON. Also, only one direction must be configured, e.g., a link from vANI to ANI must not be configured.

- From an ANI interface to the corresponding vANI interface.
Such binding allows the ONU-side ANI to inherit the T-CONT configuration data from its OLT-side vANI counterpart.
For details about the ANI and vANI, see Sections 5.1.2, 6.2.1.7, and 6.2.1.4.
These relations are applicable to all deployment uses cases.
- From an ONU-vENET interface to the corresponding OLT-vENET interface.
Such binding allows the ONU-side vENET to inherit the GEM port configuration data from its OLT-side vENET counterpart. Example of applicable deployment use cases are illustrated in Figure 4-8 for the IEEE 802.1 MAC Bridging ONU and Figure 5-3 for host interfaces in ONUs.
For details about the ONU-vENET and OLT-vENET, see Section 5.1.2.
- From a physical UNI to the corresponding OLT-vENET interface.
The binding allows the UNI interface to inherit the GEM port configuration data from its OLT-side vENET counterpart. Example of applicable deployment use cases are illustrated in Figure 4-6 for the case of TR-156.
- From a virtual UNI to the corresponding OLT-vENET interface.

The binding allows the virtual UNI interface to inherit the GEM port configuration data from its OLT-side vENET counterpart. Example of applicable deployment use cases are illustrated in Figure 4-7 for the case of TR-167, TR-142 or TR-301.

Note that the link relations are not used vertically to denote interface stack hierarchies for instance between an interface and a sub-interface.

6.2.1.7 Module bbf-xponani

This module contains a collection of YANG definitions for managing of ANI which represents the physical ONU device.

6.2.1.7.1 Submodule bbf-xponani-base

This submodule contains a collection of YANG definitions and augmentations to ietf-interfaces [5] for managing in xPON the ONU physical devices.

6.2.1.7.2 Submodule bbf-xponani-ani-body

This submodule contains data related to the actual ONU devices. Each ONU device is 1-1 associated to its unique ANI interface.

6.2.1.7.3 Submodule bbf-xponani-v-enet-body

This submodule contains data related to virtual Ethernet interfaces belonging to the physical ONU, such as the 'onu-v-enet' and the 'onu-v-vrefpoint' interfaces.

6.2.1.8 Module bbf-xpon-onu-state

This module defines state data and notifications related to each ONU.

6.2.1.9 Module bbf-xpon-onu-types

This module defines common YANG types used in the management of ONU.

6.2.1.10 Module bbf-xpon-performance-management

This module this module augments bbf-interfaces-performance-management to manage performance monitoring of xPON interfaces.

6.2.1.11 Module bbf-xpon-power-management

This module contains a collection of YANG definitions common to ONU power management.

6.2.1.12 Module bbf-xponani-power-management

This module contains a collection of YANG definitions for managing an ONU power management configuration at the ANI.

6.2.1.13 Module bbf-xponvani-power-management

This module contains a collection of YANG definitions for managing an ONU power management configuration at the vANI.

6.2.1.14 Module bbf-xpongemtcont-gemport-performance-management

This module contains a collection of YANG definitions for managing performance monitoring of GEM ports.

6.2.1.15 Module bbf-xpon-defects

This module defines xPON defects.

6.2.1.16 Module bbf-xpongemtcont-qos

This module defines the management of Quality of Service (QoS) as it relates to Transmission Containers (T-CONTs).

6.2.1.17 Module bbf-hardware-transceivers-xpons

This module augments the bbf-hardware-transceivers model to define transceiver data specific to PON applications.

6.2.2 Set of (sub)modules applicable to {OLT-ONUs} Combined-NE

This section lists the modules and submodules that apply to the {OLT-ONUs} Combined-NE:

- Module bbf-xpon-types.yang
- Module bbf-xpon-if-type.yang
- Module bbf-xpon.yang
 - Submodule bbf-xpon-base.yang
 - Submodule bbf-xpon-channel-group-body.yang
 - Submodule bbf-xpon-channel-pair-body.yang
 - Submodule bbf-xpon-channel-partition-body.yang
 - Submodule bbf-xpon-channel-termination-body.yang
 - Submodule bbf-xpon-multicast-distribution-set-body.yang
 - Submodule bbf-xpon-multicast-gemport-body.yang
 - Submodule bbf-xpon-wavelength-profile-body.yang
- Module bbf-xponvani.yang

- Submodule bbf-xponvani-base.yang
- Submodule bbf-xponvani-v-ani-body.yang
- Submodule bbf-xponvani-v-enet-body.yang
- Module bbf-xpongemtcont.yang
 - Submodule bbf-xpongemtcont-base.yang
 - Submodule bbf-xpongemtcont-gemport-body.yang
 - Submodule bbf-xpongemtcont-tcont-body.yang
 - Submodule bbf-xpongemtcont-traffic-descriptor-profile-body.yang
- Module bbf-xpongemtcont-qos.yang
- Module bbf-link-table.yang
- Module bbf-xponani.yang
 - Submodule bbf-xponani-base.yang
 - Submodule bbf-xponani-ani-body.yang
 - Submodule bbf-xponani-v-enet-body.yang
- Module bbf-xpon-onu-state.yang
- Module bbf-xpon-onu-types.yang
- Module bbf-xpon-performance-management.yang
- Module bbf-xpon-power-management.yang
- Module bbf-xponani-power-management.yang
- Module bbf-xponvani-power-management.yang
- Module bbf-xpongemtcont-gemport-performance-management.yang
- Module bbf-xpon-defects.yang
- Module bbf-hardware-transceivers-xpon.yang

6.2.3 Set of (sub)modules applicable to {OLT} Separated-NE

This section lists the modules and submodules that apply to the {OLT} Separated-NE.

The other modules and submodules from the generic xPON YANG model listed in Section 6.2.1 are not applicable to this case.

- Module bbf-xpon-types.yang
- Module bbf-xpon-if-type.yang
- Module bbf-xpon.yang
 - Submodule bbf-xpon-base.yang
 - Submodule bbf-xpon-channel-group-body.yang
 - Submodule bbf-xpon-channel-pair-body.yang
 - Submodule bbf-xpon-channel-partition-body.yang
 - Submodule bbf-xpon-channel-termination-body.yang

- Submodule bbf-xpon-multicast-distribution-set-body.yang
- Submodule bbf-xpon-multicast-gemport-body.yang
- Submodule bbf-xpon-wavelength-profile-body.yang
- Module bbf-xponvani.yang
 - Submodule bbf-xponvani-base.yang
 - Submodule bbf-xponvani-v-ani-body.yang
 - Submodule bbf-xponvani-v-enet-body.yang
- Module bbf-xpongemtcont.yang
 - Submodule bbf-xpongemtcont-base.yang
 - Submodule bbf-xpongemtcont-gemport-body.yang
 - Submodule bbf-xpongemtcont-tcont-body.yang
 - Submodule bbf-xpongemtcont-traffic-descriptor-profile-body.yang
- Module bbf-xpon-onu-state.yang
- Module bbf-xpon-onu-types.yang
- Module bbf-xpon-performance-management.yang
- Module bbf-xpon-power-management.yang
- Module bbf-xponvani-power-management.yang
- Module bbf-xpongemtcont-gemport-performance-management.yang
- Module bbf-xpon-defects.yang
- Module bbf-hardware-transceivers-xpon.yang

6.2.4 Set of (sub)modules applicable to {ONU} Separated-NE

This section lists the modules and submodules that apply to the {ONU} Separated-NE.

The other modules and submodules from the generic xPON YANG model listed in Section 6.2.1 are not applicable to this case.

- Module bbf-xpon-types.yang
- Module bbf-xpon-if-type.yang
- Module bbf-xpongemtcont.yang
 - Submodule bbf-xpongemtcont-base.yang
 - Submodule bbf-xpongemtcont-gemport-body.yang
 - Submodule bbf-xpongemtcont-tcont-body.yang
 - Submodule bbf-xpongemtcont-traffic-descriptor-profile-body.yang
- Module bbf-xpongemtcont-qos.yang
- Module bbf-xponani.yang
 - Submodule bbf-xponani-base.yang
 - Submodule bbf-xponani-ani-body.yang

- Submodule bbf-xponani-v-enet-body.yang
- Module bbf-xpon-performance-management.yang
- Module bbf-xpon-power-management.yang
- Module bbf-xponani-power-management.yang
- Module bbf-xpongemtcont-gemport-performance-management.yang
- Module bbf-xpon-defects.yang

7 Documentation

There are “README.md” files; these are short text files giving brief descriptions of the contents of the directories they are in.

Documentation for each module can be found in the *docs* folder of the corresponding directory, e.g., *networking*. There are two types of documents per each top level module.

- *.tree: Provides a tree diagram of the module.
- *.xml: Provides an XML schema representation of the module.

Each .tree and .xml file are named according to each model's module name along with –full to indicate it the full tree and not just the nodes defined in a given module (in the case of submodule support), e.g., bbf-fiber-full.tree and bbf-fiber-full.xml.

8 Dependencies on Related YANG Modules and Standards

TR-385 is based on YANG 1.1 (RFC 7950 [2]).

The following IETF YANG modules are used by TR-385:

- `ietf-interfaces.yang` [5]
- `ietf-yang-types.yang` [3]
- `ietf-inet-types` [3]

The following BBF YANG modules are used by TR-385:

- `bbf-qos-traffic-mngt.yang` [21], which imports `ietf-interfaces`, `iana-if-type` and `bbf-yang-types`.

The following BBF YANG modules can be used along with the ITU-T PON YANG Modules to provision variety of services and features for PON, such as Ethernet services and equipment management.

- BBF TR-383 Common YANG modules for Access Networks [21]

Appendix I. Summary of Key Functions (Informative)

The following table summarizes the main functions supported by the “ITU-T PON YANG Modules”.

Category	Feature
PON types	Passive Optical Networks (PON) as defined in ITU-T G.984.x, ITU-T G.987.x, ITU-T G.989.x, ITU-T G.9807.x and potentially others.
Management modes	Combined-NE mode: managing the OLT and subtending ONUs as one single combined [OLT-ONUs] network element (NE).
	Separated-NE mode: managing the OLT and ONUs as separate NEs, each NE has its own NETCONF management interface.
ONU activation and authentication	Serial number based authentication.
	Logical ONU ID (LOID) based authentication.
	Registration-ID based authentication.
	Secure Mutual Authentication – OMCI-based. ITU-T G.987.3 Annex C, ITU-T G.989.3 Annex C, and ITU-T G.9807.1 Annex C.C, ITU-T G.988 9.13.11 "Enhanced security control".
	Secure Mutual Authentication – 802.1x. ITU-T G.987.3 Annex D, ITU-T G.989.3 Annex D, and ITU-T G.9807.1 Annex C.D. 802.1x itself is out of the scope of xPON YANG.
	ONU state.
	ONU indications (new ONU discovered; ONU activated, ONU deactivated, and others.) are useful when the authentication process is done outside of the OLT.
Rogue ONU mitigation	Deactivate ONU (operation).
	Disable Serial number (operation) (disable discovery, deny upstream access).
FEC	Downstream FEC (per PON link).
	Upstream FEC (per ONU).
ONU TC data configuration	ONU-ID, Alloc-ID, GEM, Multicast GEM, management GEM port.
Data encryption configuration	Encryption configuration and state for each GEM port: in which direction encryption applies (downstream only or both downstream and upstream), and which data encryption key type (unicast or broadcast)

Dynamic Bandwidth Allocation (DBA)	Per T-CONT DBA parameters.
Distance	Maximum logical reach of a PON. [G984.3] clause 10.4.3.4.
	Maximum differential logical reach.
Protection switching	Type B protection
Ethernet services (including unicast, multicast, QoS)	TR-156 based
	TR-167 based
	IEEE 802.1 MAC Bridging ONU based
NG-PON2 specific functions	Wavelength channel handover
	Type WL protection
	ICTP protocol

Appendix II. Guidelines and Examples (Informative)

This section provides general guidelines for ITU-T PON YANG Modules. It also illustrates how the ITU-T PON YANG Modules are used to provision some fundamental xPON functions and services. The examples in this section are not meant to be exhaustive; they are given for informative purposes in order to further clarify the basic usage of ITU-T PON YANG Modules.

II.1 Examples

This example is provided for the Combined-NE mode with the assumption that the YANG features “configurable-v-ani-onu-id”, “configurable-ani-onu-id”, “configurable-alloc-id” and “configurable-gemport-id” are supported.

II.1.1 Infrastructure Configuration

Description

This use case illustrates the infrastructure configuration where the channel group, channel partition, channel pair and channel termination interfaces are created. It uses XGS-PON mode as example.

Pre-conditions

- None.

Operations

- Create wavelength profile “wavelengthprofile.A”.
 - upstream-channel-id = “0”.
 - downstream-channel-id = “0”.
- Create interface “channelgroup.1”.
- Create interface “channelparttion.1”.
 - channel-group-ref = “channelgroup.1”.
 - channel-partition-index = “0”.
 - closest-onu-distance = “0”.
 - maximum-differential-xpon-distance = “20”.
 - authentication-method = “serial-number”.
- Create interface “channelpair.1”.
 - channel-group-ref = “channelgroup.1”.
 - channel-partition-ref = “channelparttion.1”.
 - wavelength-prof-ref = “wavelengthprofile.A”.
 - channelpair-type = “xgs”.
- Create interface “channeltermination.1”.
 - channel-pair-ref = “channelpair.1”.
 - channel-termination-type = “xgs”.
 - xgs-pon-id = “1”.
- Read interface “channelpair.1”
 - actual-downstream-wavelength = “157700”.

II.1.2 ONU Configuration

Description

This use case illustrates the procedure to add an ONU to a channel partition, in Combined-NE mode.

Pre-conditions

- The ONU “ABCD00000001” is not connected to the OLT.
- The “channelgroup.1”, “channelpair.1”, “channelpartition.1” and “channeltermination.1” interfaces have been created. Refer to Section II.1.1 for the procedure.

Operations

- Create interface “v-ani.2” for the ONU.
 - channel-partition = “channelpartition.1”.
 - expected-serial-number = “ABCD00000001”.
 - preferred-channel-pair = “channelpair.1”.
 - onu-id = “32”
- Create interface “ani.1.2” for the ONU.
 - onu-id = “32”
- Create an entry in the link table list for the ONU.
 - from-interface = “ani.1.2”.
 - to-interface = “v-ani.1.2”.
- Connect ONU “ABCD00000001” to the OLT. The ONU “ABCD00000001” is ranged, activated, and uses ONU-ID 32.
- Read interface “v-ani.1.2” state data.
 - onu-id = 32.

II.1.3 T-CONT and GEM Port Configuration

Description

This use case illustrates the procedure to configure a T-CONT and a GEM port (encrypted), in Combined-NE mode. Assume that the ONU UNI is an ETH-PHY interface i.e., if:type = 'ianaift:ethernetCsmacd'.

The following configurations referred in this text use both TR-385 and TR-383 [21].

Pre-conditions

- The “channelgroup.1”, “channelpair.1”, “channelpartition.1” and “channeltermination.1” interfaces have been created. Refer to Section II.1.1 for the procedure.
- The ONU “ABCD00000001” has been configured on a channel partition, the corresponding ONU interfaces are “v-ani.1.2” and “ani.1.2”. Refer to Section II.1.2 for the procedure.
- A traffic-class to queue-id mapping profile entry “tc2queue-mapping-a” [21] has been created.

Operations

- Create OLT vENET interface “olt-venet.1.2.1” and UNI interface “phy-enet.1.2.1” for {channelpartition.1: ONU 2: Ethernet port 1}.
- Create an entry in the link table list for the ONU Ethernet interface.
 - from-interface = “phy-enet.1.2.1”.
 - to-interface = “olt-venet.1.2.1”.

- Create T-CONT “tcont.1.2.1”.
 - tm-root
 - queues.
 - tc2queue-mapping-name=”tc2queue-mapping-a”.
 - interface-reference = “v-ani.1.2”.
 - alloc-id=”678”
- Create GEM port “gemport.1.2.1”.
 - interface = “olt-venet.1.2.1”.
 - traffic-class = “0”.
 - downstream-aes-indicator = “true”.
 - tcont-ref = “tcont.1.2.1”.
 - gemport-id= “2048”
- Read T-CONT state data.
 - name = “tcont.1.2.1”, alloc-id = 678.
- Read GEM Port state data.
 - name = “gemport.1.2.1”, gemport-id = 2048.

II.1.4 Strict Priority Upstream Scheduling Configuration

Description

This use case illustrates the procedure to configure the OLT and ONU for strict priority upstream scheduling in Combined-NE mode. In this example, traffic is mapped into GEM ports and queues based on VID & p-bit values in the upstream direction.

The following configurations referred in this text use both TR-385 and TR-383 [21].

Pre-conditions

- The “channelgroup.1”, “channelpair.1”, “channelpartition.1” and “channeltermination.1” interfaces have been created. Refer to Section II.1.1 for the procedure on how to configure these interfaces.
- The ONU “ABCD00000001” has been configured on a channel partition, the corresponding ONU interfaces are “v-ani.1.2” and “ani.1.2”. Refer to Section II.1.2 for the procedure on how to configure these interfaces.
- The ONU Ethernet interface has been configured. The corresponding interface names are “olt-venet.1.2.1” and “phy-enet.1.2.1”.
- Four sub-interfaces [21] associated with the ONU Ethernet interface have been created. They are “olt-venet.1.2.1.100” and “phy-enet.1.2.1.100” for CVID1 = 100, “olt-venet.1.2.1.200” and “phy-enet.1.2.1.200” for CVID2 = 200, “olt-venet.1.2.1.300” and “phy-enet.1.2.1.300” for CVID3 = 300, “olt-venet.1.2.1.400” and “phy-enet.1.2.1.400” for CVID4 = 400. The ONU-side VLAN tagging, p-bit remarking rules and resulting traffic classes have been configured on those sub-interfaces for the corresponding flows.
- The ONU-side tm-root [21] for T-CONTs and Ethernet interfaces has been configured.
- The OLT-side classification, VLAN tagging, forwarding and QoS rules [21] between the SNI interfaces and “olt-venet.1.2.1” have been configured on the OLT side.

Operations

- Create T-CONTs “tcont.1.2.1”, “tcont.1.2.2”, “tcont.1.2.3”, and “tcont.1.2.4”. Refer to Section II.1.3 for the procedure on how to create T-CONTs.

- Create GEM ports “gemport.1.2.1”, “gemport.1.2.2”, “gemport.1.2.3”, and “gemport.1.2.4” that are associated with “olt-venet.1.2.1”. Refer to Section II.1.3 for the procedure on how to create GEM ports. The configuration below illustrates the GEM ports are pointing to “olt-venet.1.2.1”. In case flows from different sub-interfaces have overlapping resulting traffic class values, it is necessary to configure the GEM ports pointing to sub-interfaces, for example “olt-venet.1.2.1.100” and “olt-venet.1.2.1.200”.
 - GEM port “gemport.1.2.1”
 - interface = “olt-venet.1.2.1”.
 - traffic-class = “0”.
 - tcont-ref = “tcont.1.2.1”.
 - GEM port “gemport.1.2.2”
 - interface = “olt-venet.1.2.1”.
 - traffic-class = “1”.
 - tcont-ref = “tcont.1.2.2”.
 - GEM port “gemport.1.2.3”
 - interface = “olt-venet.1.2.1”.
 - traffic-class = “2”.
 - tcont-ref = “tcont.1.2.3”.
 - GEM port “gemport.1.2.4”
 - interface = “olt-venet.1.2.1”.
 - traffic-class = “3”.
 - tcont-ref = “tcont.1.2.4”.

II.1.5 IGMPv3 Transparent Snooping Function Configuration

Description

This use case illustrates the procedure to configure the OLT and ONU for IGMPv3 transparent snooping in Combined-NE mode.

The following configurations referred in this text use both TR-385 and TR-383 [21].

Pre-conditions

- In this example, the pre-conditions described in Section II.1.3 apply.

Operations

- Create unicast GEM port and T-CONT, similar to Section II.1.3.
- Create multicast GEM port “multicastgem.1.4000” for {channelpair.1}.
 - gemport-id = 4000.
 - interface = “channelpair.1”.
 - traffic-class = “0”.
 - is-broadcast = false.
- Create multicast distribution set “multicastset.1”.
 - multicast-gemport-ref = “multicastgem.1.4000”.
 - multicast-vlans = “all-multicast-vlans”.
- Create multicast-snoop-profile “mgmd-snoop.1” [21].
- Create multicast-vpn “mgmd-vpn.1” [21].
 - mgmd-mode = “snoop”.
 - multicast-snoop-profile-name = “mgmd-snoop.1”.

- multicast-subscriber-interface = “onu-user.1.100”.
- multicast-network-interface = “onu-venet.1.2.1”.
- multicast-channel = the multicast white list.

End of Broadband Forum Technical Report TR-385