

TR-331

Architecture and Technical Requirements for PON- Based Mobile Backhaul Networks

Issue: 1
Approval Date: March 2018

Notice

The Broadband Forum is a non-profit corporation organized to create guidelines for broadband network system development and deployment. This Technical Report has been approved by members of the Forum. This Technical Report is subject to change. This Technical Report is copyrighted by the Broadband Forum, and all rights are reserved. Portions of this Technical Report may be copyrighted by Broadband Forum members.

Intellectual Property

Recipients of this Technical Report are requested to submit, with their comments, notification of any relevant patent claims or other intellectual property rights of which they may be aware that might be infringed by any implementation of this Technical Report, or use of any software code normatively referenced in this Technical Report, and to provide supporting documentation.

Terms of Use

1. License

Broadband Forum hereby grants you the right, without charge, on a perpetual, non-exclusive and worldwide basis, to utilize the Technical Report for the purpose of developing, making, having made, using, marketing, importing, offering to sell or license, and selling or licensing, and to otherwise distribute, products complying with the Technical Report, in all cases subject to the conditions set forth in this notice and any relevant patent and other intellectual property rights of third parties (which may include members of Broadband Forum). This license grant does not include the right to sublicense, modify or create derivative works based upon the Technical Report except to the extent this Technical Report includes text implementable in computer code, in which case your right under this License to create and modify derivative works is limited to modifying and creating derivative works of such code. For the avoidance of doubt, except as qualified by the preceding sentence, products implementing this Technical Report are not deemed to be derivative works of the Technical Report.

2. NO WARRANTIES

THIS TECHNICAL REPORT IS BEING OFFERED WITHOUT ANY WARRANTY WHATSOEVER, AND IN PARTICULAR, ANY WARRANTY OF NONINFRINGEMENT IS EXPRESSLY DISCLAIMED. ANY USE OF THIS TECHNICAL REPORT SHALL BE MADE ENTIRELY AT THE IMPLEMENTER'S OWN RISK, AND NEITHER THE BROADBAND FORUM, NOR ANY OF ITS MEMBERS OR SUBMITTERS, SHALL HAVE ANY LIABILITY WHATSOEVER TO ANY IMPLEMENTER OR THIRD PARTY FOR ANY DAMAGES OF ANY NATURE WHATSOEVER, DIRECTLY OR INDIRECTLY, ARISING FROM THE USE OF THIS TECHNICAL REPORT.

3. THIRD PARTY RIGHTS

Without limiting the generality of Section 2 above, BROADBAND FORUM ASSUMES NO RESPONSIBILITY TO COMPILE, CONFIRM, UPDATE OR MAKE PUBLIC ANY THIRD PARTY ASSERTIONS OF PATENT OR OTHER INTELLECTUAL PROPERTY RIGHTS THAT MIGHT NOW OR IN THE FUTURE BE INFRINGED BY AN IMPLEMENTATION OF THE TECHNICAL REPORT IN ITS CURRENT, OR IN ANY FUTURE FORM. IF ANY SUCH

RIGHTS ARE DESCRIBED ON THE TECHNICAL REPORT, BROADBAND FORUM TAKES NO POSITION AS TO THE VALIDITY OR INVALIDITY OF SUCH ASSERTIONS, OR THAT ALL SUCH ASSERTIONS THAT HAVE OR MAY BE MADE ARE SO LISTED.

The text of this notice must be included in all copies of this Technical Report.

Issue History

Issue Number	Approval Date	Publication Date	Issue Editor	Changes
1	March 16, 2018	April 19, 2018	Duane Remein, Huawei Technologies Chengbin Shen, China Telecom	Original

Comments or questions about this Broadband Forum Technical Report should be directed to help@broadband-forum.org.

Editors

Chengbin Shen	China Telecom
Jin Jialiang	China Telecom
Wei Lin	Huawei Technologies
Robin Grindley	Broadcom Co. Ltd
Duane Remein	Huawei Technologies

**Fiber Access
Network
WA Directors**

Michael Shaffer	Alcatel Lucent
Greg Bathrick	Calix
Wei Lin	Huawei Technologies

Table of Contents

Executive Summary	8
1 Purpose and Scope	9
1.1 Purpose	9
1.2 Scope	9
2 References and Terminology	10
2.1 Conventions	10
2.2 References	10
2.3 Definitions	13
2.4 Abbreviations	14
3 Technical Report Impact	16
3.1 Energy Efficiency	16
3.2 Security	16
3.3 Privacy	16
4 Reference Architecture	17
4.1 System Architecture	17
4.2 Supported Mobile Systems and PON Types	18
5 Deployment Use Cases	19
5.1 Mobile Backhaul Only	19
5.1.1 Use Case Overview	19
5.1.2 Deployment Context	20
5.1.3 CBU Details	20
5.2 Mobile Backhaul+Business (MBH + B).....	21
5.2.1 Use Case Overview	21
5.2.2 Deployment Context	22
5.2.3 CBU Details	22
5.3 Mobile Backhaul + Residential (MBH + R).....	22
5.3.1 Use Case Overview	22
5.3.2 Deployment Context	24
5.3.3 CBU Details	24
5.3.4 Other Considerations	24
5.4 Mobile Backhaul + WLAN AP (MBH + W).....	24
5.4.1 Use Case Overview	24
5.4.2 Deployment Context	25
5.4.3 ONU Details.....	26
5.4.4 Other Considerations	26
5.5 Mobile Backhaul + WLAN AP + Residential (MBH + W + R).....	26

5.5.1	<i>Use Case Overview</i>	26
5.5.2	<i>Deployment Context</i>	27
5.5.3	<i>ONU details</i>	28
5.5.4	<i>Other Considerations</i>	28
5.6	Mobile Backhaul + Business + Residential (MBH + B + R)	28
5.6.1	<i>Use Case Overview</i>	28
5.6.2	<i>Use Case Description</i>	29
5.6.3	<i>Deployment Context</i>	29
5.6.4	<i>CBU Details</i>	29
6	Mobile System's Generic Requirements for Backhaul System	30
6.1	Bandwidth	30
6.2	Synchronization	30
6.3	Delay	32
6.4	Traffic Management	33
6.5	OAM	34
6.6	Resiliency	34
6.7	Other Requirements	35
7	Nodal Technical Requirements for PON Systems	36
7.1	Requirements for OLT Equipment	36
7.1.1	<i>Interfaces</i>	36
7.1.2	<i>Synchronization Requirements (Frequency and Phase)</i>	36
7.1.3	<i>Traffic Management (VLAN, QoS, etc.)</i>	37
7.1.4	<i>Multicast</i>	37
7.1.5	<i>OAM</i>	37
7.1.6	<i>Resiliency</i>	38
7.2	Requirements for ONU Equipment	38
7.2.1	<i>Interfaces</i>	38
7.2.2	<i>Synchronization Requirements (Frequency and Phase)</i>	39
7.2.3	<i>Traffic Management (VLAN, QoS, etc.)</i>	39
7.2.4	<i>Multicast</i>	40
7.2.5	<i>OAM</i>	40
7.2.6	<i>Resiliency</i>	40
Appendix A	Some Implementation Guidelines	42
A.1	ODN Modeling	42
A.1.1	<i>Comparison Between Point to Point ODN and PON-based ODN</i>	42
A.1.2	<i>ODN Modeling Discussion</i>	43
A.1.2.1	<i>General Discussion</i>	43
A.1.2.2	<i>Deployment Modeling</i>	43

Table of Figures

Figure 1 - Reference Architecture for MBH network using PON as the access technology.	18
Figure 2 – PON port provides only backhaul for mobile base station	19
Figure 3 – PON port providing both MBH and business services	21
Figure 4 – Existing residential PON port used for small cell backhaul	23
Figure 5 – PON port providing both MBH and WLAN AP services	25
Figure 6 – PON port providing MBH, WLAN AP and residential services	27
Figure 7 – PON System providing MBH, residential and business services simultaneously	29
Figure 8 – Synchronization Architecture for Mobile Backhaul	31
Figure 9 – Scope of the standardized QCI characteristics for client/server communication	32
Figure 10 – Point to point ODN structure for MBH	42
Figure 11 – PON-based point to multi-point ODN structure for MBH	42
Figure 12 – Typical access ODN topology	43

Table of Tables

Table 1 – Supported Mobile Systems and PON Types	19
Table 2 – Synchronization requirements of typical mobile systems	30
Table 3 – Packet delay budget considerations	35

Executive Summary

A number of Broadband Forum Technical Reports are dedicated to the description of an Ethernet-based architecture optimized for multi-service passive optical networks (PONs) and technical requirements for PON systems catering to both residential and business customers.

Based on TR-221 [4], TR-331 extends the architecture and technical requirements to provide enhanced mobile backhaul (MBH) functionality. These requirements cover system architecture, use cases, and technical requirements as well as some implementation guidelines, so as to foster multi-vendor interoperability. The specifications in TR-331 apply to both ITU-T and IEEE PON systems and focus on Long Term Evolution (LTE) and LTE-advanced.

1 Purpose and Scope

1.1 Purpose

In TR-221 [4], technical architecture and equipment requirements for Multiprotocol Label Switching based mobile backhaul networks have already been defined. It provides an end-to-end reference architecture for transport services addressing control, user and management traffic in mobile networks. Some of the benefits and requirements that apply to access nodes are abstract enough to apply to many types of access.

Recognizing these benefits, some service providers planning ITU-T/IEEE PON deployments are willing to refer to the elements of the architecture and requirements provided by TR-221, but find that there are some aspects of PON deployment that require definition and could benefit from standardization. TR-331 builds on TR-221 and provides the requirements and approaches to support PON based access in the context of TR-221.

This Technical Report is intended to provide the architectural basis and technical requirements in addition to those specified in TR-221 that are needed to successfully deploy PON access nodes within a TR-221 architecture, either independently or alongside other TR-221 access node types.

1.2 Scope

The focus of TR-331 is the development of PON specific access node requirements for MBH networks that foster multi-vendor interoperability. The referenced mobile networks focus is described in TR-221 and Amendments, TR-224 [5], TR-178 [3], TR-350 [7], etc., including LTE and LTE advanced.

This work will include the following.

- 1) Architectural definitions.
- 2) Use cases, including
 - a) MBH-only networks,
 - b) MBH + business (MBH+B) networks,
 - c) MBH + residential (MBH+R) networks,
 - d) MBH + Public WiFi (MBH+W) networks,
 - e) MBH+ business + residential (MBH+B+R) networks.
- 3) PON-specific technical requirements for access nodes in mobile networks as defined in TR-221.
- 4) Specifications for ITU-T/IEEE PON systems.
- 5) Optical line terminal (OLT) specific and optical network unit (ONU) specific requirements.
- 6) Implementation guidelines as optical distribution network (ODN) modeling.

2 References and Terminology

2.1 Conventions

In this Technical Report, several words are used to signify the requirements of the specification. These words are always capitalized. More information can be found in RFC 2119 [35].

MUST	This word, or the term “REQUIRED”, means that the definition is an absolute requirement of the specification.
MUST NOT	This phrase means that the definition is an absolute prohibition of the specification.
SHOULD	This word, or the term “RECOMMENDED”, means that there could exist valid reasons in particular circumstances to ignore this item, but the full implications need to be understood and carefully weighed before choosing a different course.
SHOULD NOT	This phrase, or the phrase "NOT RECOMMENDED" means that there could exist valid reasons in particular circumstances when the particular behavior is acceptable or even useful, but the full implications need to be understood and the case carefully weighed before implementing any behavior described with this label.
MAY	This word, or the term “OPTIONAL”, means that this item is one of an allowed set of alternatives. An implementation that does not include this option MUST be prepared to inter-operate with another implementation that does include the option.

2.2 References

The following references are of relevance to this Technical Report. At the time of publication, the editions indicated were valid. All references are subject to revision; users of this Technical Report are therefore encouraged to investigate the possibility of applying the most recent edition of the references listed below.

A list of currently valid Broadband Forum Technical Reports is published at www.broadband-forum.org.

Document	Title	Source	Year
[1] TR-069	<i>CPE WAN Management Protocol</i>	BBF	2006
[2] TR-156	<i>Using GPON Access in the context of TR-101</i>	BBF	2012
[3] TR-178	<i>Multi-service Broadband Network Architecture and Nodal Requirements</i>	BBF	2014
[4] TR-221	<i>Technical Specifications for MPLS in Mobile</i>	BBF	2011

Backhaul Networks

[5]	TR-224	<i>Technical Specification for MPLS in Carrier Ethernet Networks</i>	BBF	2014
[6]	TR-301 Issue 2	<i>Architecture and Requirements for Fiber to the Distribution Point</i>	BBF	2017
[7]	TR-350	<i>Ethernet Services using BGP MPLS Based Ethernet VPNs (EVPN)</i>	BBF	2015
[8]	3GPP TS 23.203	<i>3rd Generation Partnership Project; Technical Specification Group Services and System Aspects; Policy and charging control architecture (Release 10)</i>	3GPP	2013
[9]	G.703	<i>Physical/electrical characteristics of hierarchical digital interfaces</i>	ITU-T	2016
[10]	G.707	<i>Network Node Interface For The Synchronous Digital Hierarchy (SDH)</i>	ITU-T	2003
[11]	G.811	<i>Timing Characteristics of Primary Reference Clocks</i>	ITU-T	1997
[12]	G.823	<i>The Control Of Jitter and Wander Within Digital Networks Which are Based on the 2048 Kbit/S Hierarchy</i>	ITU-T	2000
[13]	G.825	<i>The control of jitter and wander within digital networks which are based on the synchronous digital hierarchy (SDH)</i>	ITU-T	1993
[14]	G.8261	<i>Timing and Synchronization Aspects in Packet Networks</i>	ITU-T	2007
[15]	G.8261.1	<i>Packet delay variation network limits applicable to packet-based methods (Frequency synchronization)</i>	ITU-T	2012
[16]	G.8262	<i>Timing characteristics of synchronous Ethernet equipment slave clock (EEC)</i>	ITU-T	2007
[17]	G.8263	<i>Timing characteristics of packet-based equipment clocks</i>	ITU-T	2008
[18]	G.8265	<i>Architecture and requirements for packet-based frequency delivery</i>	ITU-T	2010
[19]	G.8265.1	<i>Precision time protocol telecom profile for frequency synchronization</i>	ITU-T	2013
[20]	G.8271.1	<i>Network Limits for Time Synchronization in Packet Networks</i>	ITU-T	2013
[21]	G.8273.2	<i>Timing characteristics of telecom boundary clocks and telecom time slave clocks</i>	ITU-T	2014
[22]	G.8275	<i>Architecture and requirements for packet-based time and phase distribution</i>	ITU-T	2017
[23]	G.8275.1	<i>Precision time protocol telecom profile for phase/time synchronization with full timing support from the network</i>	ITU-T	2016
[24]	G.8275.2	<i>Precision time protocol telecom profile for time/phase synchronization with partial timing support from the</i>	ITU-T	2016

network

- | | | | | |
|------|--------------|---|-------|------|
| [25] | G.984.1 | <i>Gigabit-capable passive optical networks (GPON): General characteristics</i> | ITU-T | 2008 |
| [26] | G.984.1.Amd2 | <i>Gigabit-capable passive optical networks (GPON): General characteristics, Amendment 2</i> | ITU-T | 2012 |
| [27] | G.984.2 | <i>Gigabit-capable Passive Optical Networks (G-PON): Physical Media Dependent (PMD) layer specification</i> | ITU-T | 2003 |
| [28] | G.984.3 | <i>Gigabit-capable passive optical networks (G-PON): Transmission convergence layer specification</i> | ITU-T | 2014 |
| [29] | G.984.4 | <i>Gigabit-capable passive optical networks (G-PON): ONT management and control interface specification</i> | ITU-T | 2008 |
| [30] | G.987.1 | <i>10-Gigabit-capable passive optical networks (XG-PON): General requirements</i> | ITU-T | 2003 |
| [31] | G.988 | <i>ONU management and control interface (OMCI) specification</i> | ITU-T | 2012 |
| [32] | G.9807.1 | <i>10-Gigabit-capable symmetric passive optical network (XGS-PON)</i> | ITU-T | 2016 |
| [33] | MEF 4 | <i>Metro Ethernet Network Architecture Framework - Part 1: Generic Framework</i> | MEF | 2016 |
| [34] | MEF 22.2 | <i>Mobile Backhaul Phase 3</i> | MEF | 2016 |
| [35] | RFC 2119 | <i>Key words for use in RFCs to Indicate Requirement Levels</i> | IETF | 1997 |
| [36] | RFC 5798 | <i>Virtual Router Redundancy Protocol (VRRP) Version 3 for IPv4 and IPv6</i> | IETF | 2010 |
| [37] | RFC 5880 | <i>Bidirectional Forwarding Detection (BFD).</i> | IETF | 2010 |
| [38] | Std 1588 | <i>Precision Clock Synchronization Protocol for Networked Measurement and Control Systems</i> | IEEE | 2008 |
| [39] | Std 1904.1 | <i>IEEE Standard for Service Interoperability in Ethernet Passive Optical Networks (SIEPON)</i> | IEEE | 2017 |
| [40] | Std 802.1AS | <i>Local and metropolitan area networks—Timing and Synchronization for Time-Sensitive Applications in Bridged Local Area Networks</i> | IEEE | 2011 |
| [41] | Std 802.1Q | <i>IEEE Standard for Local and metropolitan area networks—Bridges and Bridged Networks</i> | IEEE | 2014 |
| [42] | Std 802.1AX | <i>IEEE Standard for Local and metropolitan area networks--Link Aggregation</i> | IEEE | 2008 |

[43]	Std 802.3	<i>CSMA/CD access method and physical layer specifications</i>	IEEE	2015
[44]	Std 802.3av	<i>10Gb/s Ethernet Passive Optical Network</i>	IEEE	2009
[45]	Std 802.11n	<i>Wireless LAN Medium Access Control (MAC) and Physical Layer (PHY) Specifications Amendment 5: Enhancements for Higher Throughput</i>	IEEE	2009
[46]	Std 802.11ac	<i>Wireless LAN Medium Access Control (MAC) and Physical Layer (PHY) Specifications Amendment 4: Enhancements for Very Higher Throughput for Operation in Bands below 6 GHz</i>	IEEE	2013
[47]	Std 802.11ag	<i>Connectivity Fault Management</i>	IEEE	2007
[48]	NGNM Requirement	<i>Next Generation Mobile Networks Optimised Backhaul Requirements</i>	NGMN Alliance	2008

2.3 Definitions

The following terminology is used throughout this Technical Report.

1PPS+TOD	1PPS is an electrical signal that has a width of less than one second and a sharply rising or abruptly falling edge that accurately repeats once per second. TOD stands for Time of Day.
CBU	Cellular Backhaul Unit. A type of ONU, which exists in a PON-enabled Cell Site Gateway as defined in TR-221 [4].
EPON	Ethernet Passive Optical Network, as specified by IEEE Std 802.3 [43].
GPON	Gigabit-capable passive optical networks, as specified by ITU-T G.984 series.
MBU	Multi-Backhaul Unit, a special form of Cellular Backhaul Unit (CBU), which is used to accommodate more small cells stations and wireless LAN services.
OAM	Operations, Administration, and Maintenance (OAM). A sublayer that provides a mechanism for managing link operation, including ONU authentication, ONU configuration, ONU software-image management, event notification, and performance monitoring, used by IEEE PON systems.
ODN	Optical Distribution Network. The physical medium that connects an OLT to its subtended ONUs. The ODN is comprised of various passive components, including the optical fiber, splitter or splitters, and optical connectors.
OLT	Optical Line Terminal. A device that terminates the common (root) endpoint of an ODN and implements a PON protocol. The OLT provides management and maintenance functions for the subtended ODN and ONUs.
OMCI	ONU Management & Control Interface. A protocol providing mechanisms for management and control of ONUs remotely, used by ITU-T PON systems.
ONU	Optical Network Unit. A generic term denoting a functional element that terminates any one of the distributed (leaf) endpoints of an ODN, implements a PON protocol, and provides subscriber service interfaces. In some contexts an ONU supports interfaces for multiple subscribers.

PON	Passive Optical Network. A PON includes an OLT, one or more ONUs, and the ODN.
PTP ¹	Precision Time Protocol. The PTP is a protocol used to synchronize clocks throughout a computer network. Several PTP-based solutions / profiles have been defined by ITU-T. G.8265.1 [19] specifies a PTP profile for carrying frequency synchronization. The solution includes an architecture specified by G.8265 [18], clocks defined in G.8263 [17] and network limits in G.8261.1 [15]. G.8275.1 [19] specifies a PTP profile for carrying time synchronization. The solution includes an architecture specified by G.8275 [22], the Telecom Boundary Clock and Telecom Slave Clock defined in G.8273.2 [21] and network limits in 8271.1 [20].
RAN	Radio Access Network. A RAN is part of a mobile telecommunication system. Conceptually, it resides between a device such as a mobile phone, a computer, or any remotely controlled machine and the core network to which it provides a connection. Depending on the standard, mobile phones and other wireless connected devices are varyingly known as user equipment, terminal equipment, mobile station, etc. RAN functionality is typically provided by a silicon chip residing in both the core network as well as the user equipment.
WLAN AP	Wireless local area network access point. In this document this term refers to a public hotspot WLAN application only and does not apply to a private WiFi connection.

2.4 Abbreviations

This Technical Report uses the following abbreviations:

aGW	Access Gateway
BITS	Building Integrated Timing System
CoS	class of service
eNB	Evolved Universal Terrestrial Radio Access NodeB
FE	Fast Ethernet
GE	Gigabit Ethernet
HGU	Home Gateway Unit
IP	internet protocol
IPsec	internet protocol security
L2	layer two
LTE	Long Term Evolution
MBU	Multi-Backhaul Unit

¹ The partial timing support profile (G.8275.2 [15]) is also available but clocks and network performance are still under development

MIMO	multiple input, multiple output
PCEF	Policy Charging Enforcement Function
POTS	Plain Old Telephone Service
QoS	Quality of Service
SBU	small business unit
SFP	small form factor
SFP(+)	small form factor plus
SFU	Single Family Unit
SyncE	Synchronous Ethernet
TR	Technical Report
WT	Working Text

3 Technical Report Impact

3.1 Energy Efficiency

Due to its point to multi-point architecture, in a PON network, multiple Evolved Universal Terrestrial Radio Access NodeBs (eNBs)/mobile stations access the same OLT PON port, so the equipment energy consumption on the central office side is minimized when compared to traditional point-to-point radio access network (RAN) transport technologies.

3.2 Security

Security requirements for the RAN systems are specified by 3GPP [8]. It is assumed that security risks on the Ethernet/IP based RAN are not neglected. The PON system provides necessary security functions and interwork with other uplinked RAN systems.

3.3 Privacy

Any issues regarding privacy are not affected by TR-331.

4 Reference Architecture

4.1 System Architecture

Figure 1 illustrates the reference architecture, depicting the access portion of the PON-based mobile backhaul network and considering possible types of data transport technologies used in backhaul networks.

For LTE and LTE-advanced mobile networks, timing distribution is of particular interest; therefore Figure 1 shows timing and data connections separately. In real implementations, these can share a single physical link (e.g., synchronous Ethernet (SyncE, defined in G.8262 [16]) and Precision Time Protocol (PTP)). As for timing implementation, some networks can use PTP, and others can forego PTP entirely and just use the native timing distribution methodologies available for PON (ITU G.984.1 Amd2 [26] or IEEE Std 802.1AS [40]). These different technical approaches will most likely generate different nodal requirements.

Reference architectures of mobile aggregation and mobile core networks are not given here, (see TR-221 [4]).

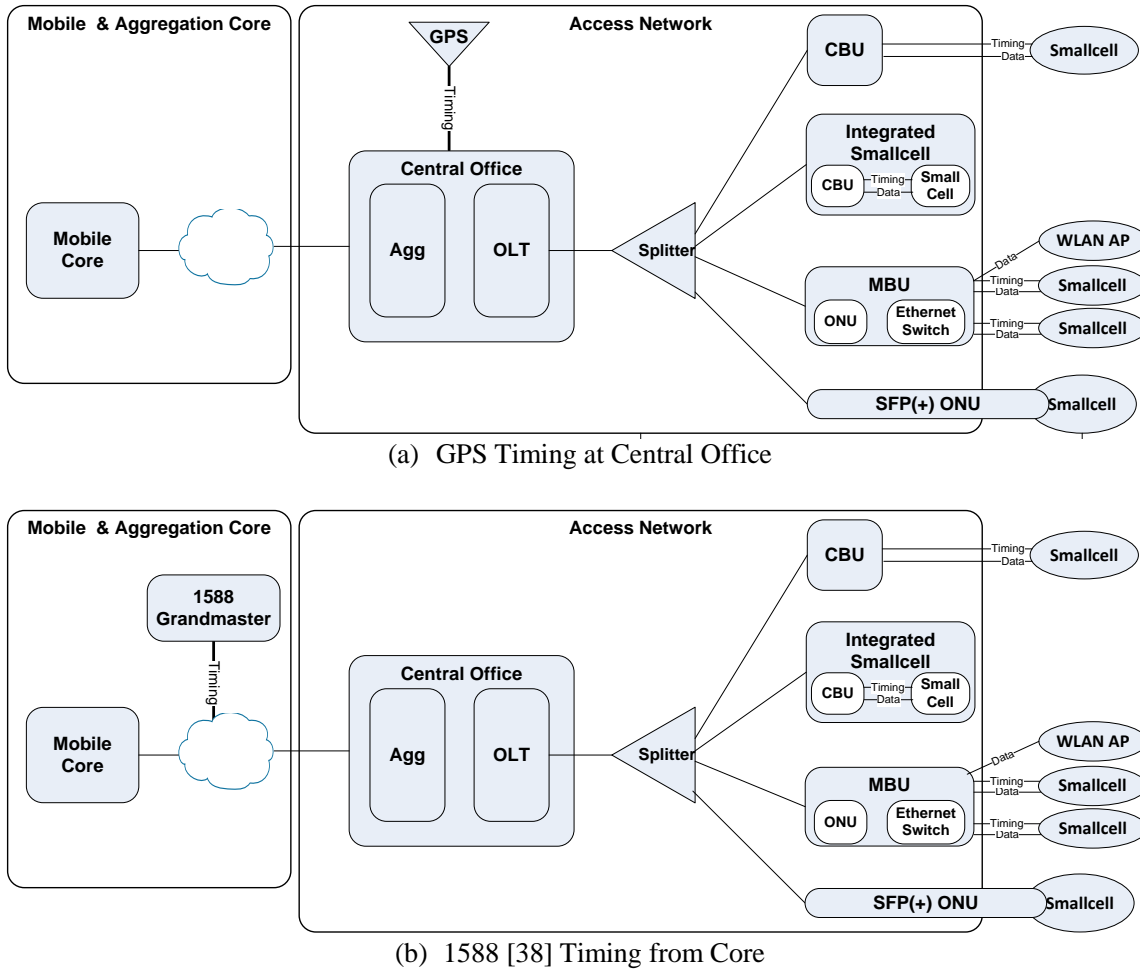

Figure 1 – Reference Architecture for MBH network using PON as the access technology.

In Figure 1, fiber to the drop point as described in TR-301 Issue 2 [6] and a small form factor plus (SFP(+)) ONU are also proposed as two typical backhaul approaches.

Some overview description of PON-based mobile backhaul system will be given here.

4.2 Supported Mobile Systems and PON Types

The reference architecture accommodates various scenarios that are based on three types of mobile systems, FDD LTE, TDD LTE, and LTE-advanced, as listed in Table 1. Each of these mobile systems can be implemented as a macro cell or as small cells or as a combination of these cell sizes. Furthermore, either IEEE PONs (1G-EPON or 10G-EPON) or ITU-T PONs (GPON, XG-PON, NG-PON2, etc.) can be used with these mobile systems.

Table 1 – Supported Mobile Systems and PON Types

Mobile Networks	Specification
FDD LTE	R8,R9
TDD LTE	R8,R9
LTE-advanced	R10, R12

In the context of the TR-221, these mobile backhaul scenarios are referred to as internet protocol (IP) transport network layer scenarios since all LTE systems apply IP as their transport protocol for the data traffic.

5 Deployment Use Cases

Mobile systems can co-exist with other systems such as WiFi, Business, and residential systems on a single ODN.

5.1 Mobile Backhaul Only

5.1.1 Use Case Overview

5.1.1.1 Primary Motivation

The MBH only use case addresses the situation where only MBH service is delivered and there is no co-existence with other services over a single PON port.

5.1.1.2 Figure

The MBH only use case is illustrated in Figure 2. The same Gigabit Ethernet (GE) interface can support delivery of user traffic together with SyncE or PTP.

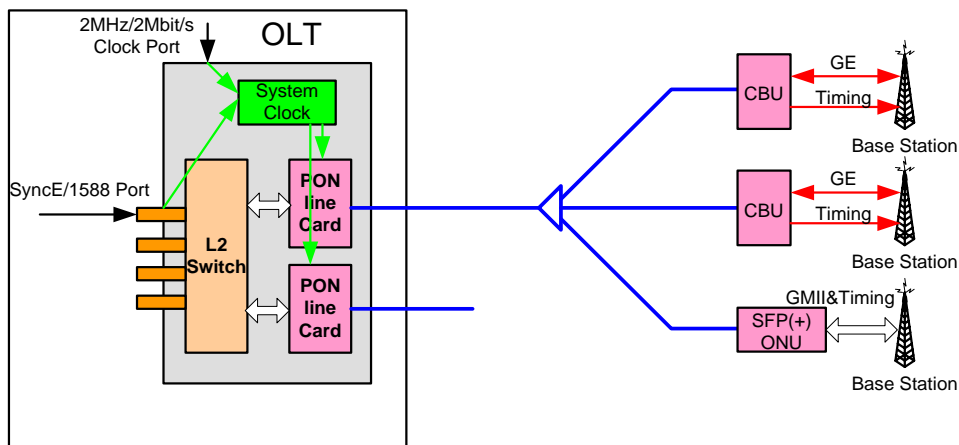

Figure 2 – PON port provides only backhaul for mobile base station

5.1.1.3 Use Case Description

A single PON port is used to deliver only MBH service, the PON port is dedicated and there are no other services co-existing with MBH.

At the ONU, both data channel and timing signal are provided to the mobile base station. The base station can be a macro-cell or a small cell. There are two types of ONUs: cellular backhaul unit (CBU) and SFP(+) ONUs.

The PON solution can use one of several mechanisms for frequency and time/phase synchronization as described in 6.2.

At the OLT, time/phase information can be delivered through the PON port to a CBU and further to the specific UNI port (1PPS+TOD or internal interface) or to the traffic GE interface delivering PTP to an eNB/mobile station.

At the OLT, frequency information carried in 2MHz/2Mbit/s clock interface, SyncE interface, or GPS interface, is received and delivered through the PON port to the CBU and further to the specific UNI port(1PPS+TOD or internal interface).

The PON solution needs to comply with the frequency and time/phase requirements in the G.984.1[25] and IEEE802.3AS [40] series recommendations to ensure the frequency and time/phase information is transported correctly to maintain timing integrity and make use of the integrated timing capabilities of the PON system to give the best timing performance with minimal accumulated error.

5.1.2 Deployment Context

In some urban areas, there are high densities of mobile subscribers and the mobile coverage environment is highly variable. Small cells can be used to offload a macro-cell or access blind spots in these areas. These low power small cells can be combined with high power macro-cells to form a heterogeneous network. Considering the need to add or remove such small cells often, some operators plan a dedicated PON port or PON line card to provide MBH service in these specific geographic areas.

An SFP(+) ONU can be deployed when the small cell equipment supports an SFP(+) interface with both data and synchronization functions.

5.1.3 CBU Details

The CBU is expected to have several form factors.

1. A miniONU with one GE port and one 1PPS+TOD interface suitable for inserting within a lamppost pillar.
2. A small form factor SFP or SFP+ ONU that can be inserted into other units, e.g., base station equipment.
3. A multi-backhaul unit (MBU) can be used in some scenarios.

The CBU could be environmentally hardened according to local specifications and regulations.

5.2 Mobile Backhaul+Business (MBH + B)

5.2.1 Use Case Overview

5.2.1.1 Primary Motivation

The MBH+B use case addresses the situation where both MBH and business access service are delivered over a single PON port.

5.2.1.2 Figure

The MBH+B use case is illustrated in Figure 3. The same GE interface supports delivery of user traffic together with SyncE and PTP.

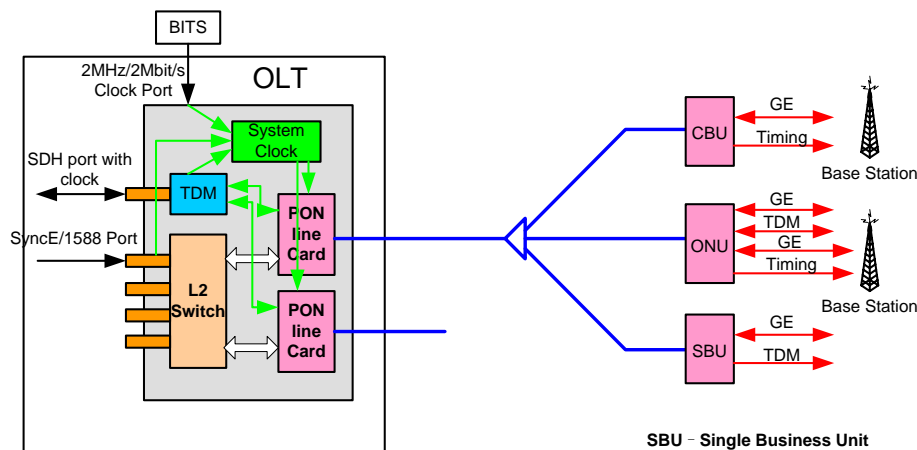

Figure 3 – PON port providing both MBH and business services

5.2.1.3 Use Case Description

A single PON port is used to deliver both MBH service and business services. The business services include not only GE but also TDM services (T1/E1, T3/E3, OC3/STM-1, OC-12/STM-4, etc.).

An ONU delivers both data and timing signals for the mobile base station, while for business applications both GE and TDM services are provided. Normally, the base station is a small cell, and a CBU or SFP(+) ONU is used for MBH services, while a small business unit (SBU) can be used for business services. In some special situations, one ONU provides MBH, GE, and TDM services simultaneously.

The PON solution can use one of several mechanisms for frequency and time/phase synchronization as described in 6.2. The solution will support the required ONU types, including CBU, SFP(+) ONU, and SBU.

At the OLT, time/phase information is received from the PON port of the CBU or SFP(+) ONU, and forwarded to the specific UNI port (1PPS+TOD or internal interface) or to the traffic GE interface delivering PTP to eNB/mobile station.

At the OLT, frequency information carried in 2MHz/2Mbit/s Building Integrated Timing System (BITS) clock interface, SDH line clock, Sync-E interface, or GPS interface is received from the PON port of the CBU and forwarded to the specific UNI port (1PPS+TOD or internal interface) or to the traffic GE interface delivering SyncE to eNB/mobile station. A clock source switching process is necessary for scenarios with multiple clock sources.

The PON solution needs to comply with the frequency and time/phase requirements in the G.984.1 [25] and IEEE802.3 series recommendations to ensure the frequency and time/phase information are transported correctly to maintain timing integrity and to make use of the integrated timing capabilities to give the best timing performance with minimal accumulated error.

5.2.2 Deployment Context

In some urban business areas, there is demand for small cells used to offload a macrocell or access blind spots (especially indoors) as well as for business access services. Small cell backhaul service can be provided together with business access by PON systems. Operators find that providing both MBH and business access over the same PON port in locations with high business densities is cost-efficient and easy-to-do.

The CBU, SFP(+) ONU, or other ONU for business services are to be deployed located in an indoor environment.

An SFP(+) ONU can be deployed when the small cell equipment supports an SFP(+) interface with both data and synchronization functions.

5.2.3 CBU Details

The CBU is expected to have several form factors.

1. A mini ONU with one GE port and one 1PPS+TOD interface suitable for inserting within a lamppost pillar.
2. An SFP or SFP+ ONU that can be inserted into other units, e.g., base station equipment.
3. An MBU can be used in some scenarios.

5.3 Mobile Backhaul + Residential (MBH + R)

5.3.1 Use Case Overview

5.3.1.1 Primary Motivation

The MBH + R use case addresses the situation where both MBH and residential access services are delivered over a single PON port.

5.3.1.2 Figure

Figure 4 provides a use case for MBH+R. The PON is mainly used for small cell backhaul. The same GE interface supports delivery of user traffic together with SyncE and PTP.

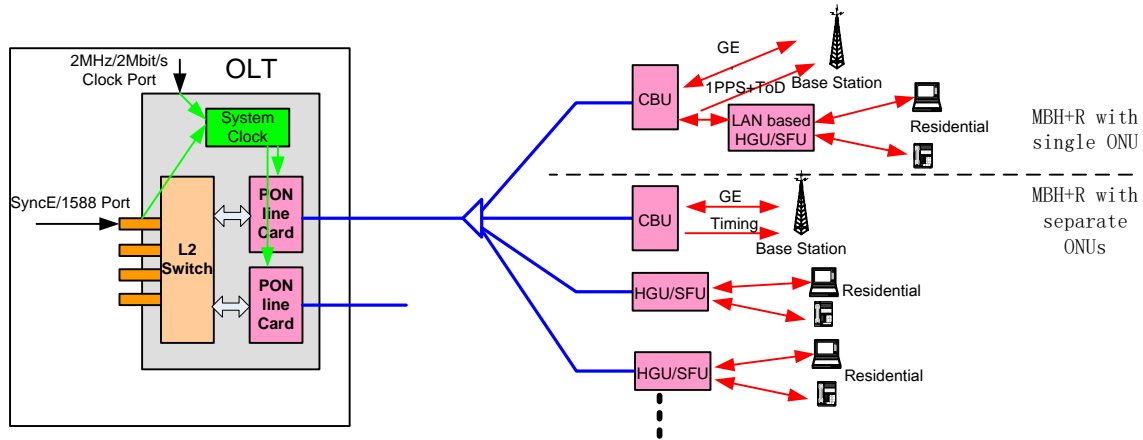

Figure 4 – Existing residential PON port used for small cell backhaul

5.3.1.3 Use Case Description

In this scenario, one or more small cells are installed in residential areas to correct blind spots. The PON ODN has previously been installed in this residential area. Some ODN ports can be used for small cell access. It is important that the distance from the small cell to an ODN splitter location is small (i.e., a few hundreds of meters maximum) so the cost of running the needed drop fiber is minimized.

For example, the OLT can be in a point of presence where there exists access points to an IP based backhaul network, a traditional switched voice network, and optionally another base station. The OLT forwards MBH traffic from the small cells to the IP backhaul network optionally via the other base station. Internet traffic, from either the MBH or the residential subscribers is forwarded to the Metro IP network and fixed voice traffic is forwarded to a switched voice network.

The MBH and residential services can be carried by the same ONU or two distinctive ONUs, as Figure 4 shows.

In the single-ONU case, the ONU has one GE port, one 1PPS+TOD interface for mobile backhaul service, and separate GE ports for residential services. A home gateway / single family unit (HGU/SFU) with a LAN-based access network interface port can be connected to the ONU to provide internet and Plain Old Telephone Service (POTS) for residential users. In this case, the ONU would have multiple GE UNI ports for carrying MBH and residential services simultaneously.

In the case with separate ONUs, the CBU and the HGU/SFU share the same ODN, the small cell backhaul service is carried by the CBU with one GE port and one 1PPS+TOD interface, while the residential services are carried by the HGU/SFU. In this case, the CBU and HGU/SFU are not required to have multiple UNI ports. However, the splitter ratio of the ODN needs to be carefully considered in advance, as the number of ONUs increases.

5.3.2 Deployment Context

In some urban residential areas, there are demands for small cells used to offload macro cells and access blind spots (especially indoors). These small cell backhaul services can be provided along with residential access via PON systems. Operators find that providing both MBH and residential access over the same PON port is cost-efficient and easy-to-do. The CBU, SFP(+) ONU, and SFU/HGU are deployed in an indoor environment. An SFP(+) ONU can be deployed when the small cell equipment supports an SFP(+) interface with both data and synchronization functions.

5.3.3 CBU Details

The ONU is expected to have several form factors.

1. A CBU/HGU/SFU with multiple GE ports and one 1PPS+TOD interface, for the single-ONU case in Figure 4.
2. A mini CBU with one GE port and one 1PPS+TOD interface suitable for inserting within a lamppost pillar.
3. An SFP or SFP+ ONU that can be inserted into other units, e.g., base station equipment, for the separate ONU case in Figure 4.
4. A conventional HGU/SFU with one or multiple GE ports, as well as a POTS interface for residential services, for the separate ONU case in Figure 4.

5.3.4 Other Considerations

For the MBH+R use case, the bandwidth and layer two (L2) Quality of Service (QoS) are configured to guarantee mobile services in the PON system.

In the separate ONU case in Figure 4, a single small cell can cover several family units, thus the ratio between CBU for MBH and HGU/SFU for residential clients can be 1:N.

5.4 Mobile Backhaul + WLAN AP (MBH + W)

5.4.1 Use Case Overview

5.4.1.1 Primary Motivation

The MBH + W use case addresses the situation where both MBH and WLAN AP transport service are delivered in one PON port.

5.4.1.2 Figure

The MBH + W use case is illustrated in Figure 5. The same GE interface supports delivery of user traffic together with SyncE and PTP.

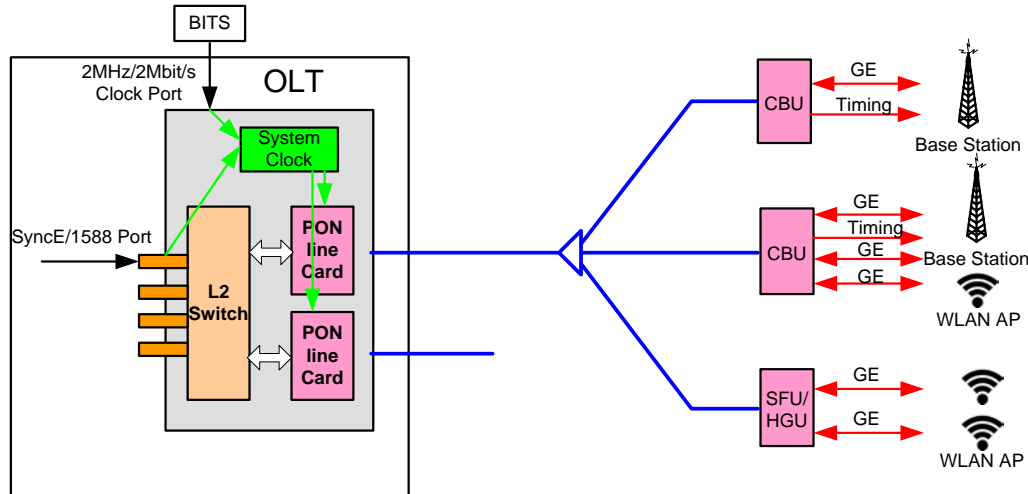

Figure 5 – PON port providing both MBH and WLAN AP services

5.4.1.3 Use Case Description

OLT PON ports can be used to deliver MBH services and WLAN AP services simultaneously. Given that IEEE Std 802.11n [45] and 802.11ac [46] are massively deployed, the typical WLAN AP transport service needs a GE interface. Normally, a mobile base station is backhauled by a dedicated CBU, and multiple WLAN APs can be transported using one SFU. In some special situations (e.g., WLAN APs co-locate with mobile base station), one CBU can provide MBH and WLAN AP transport services simultaneously so as to reduce cost and ease installation.

At the CBU, both the GE data channel and the timing signal are provided for the mobile base station, while separate GE data channels provide for WLAN AP services. Normally, the typical base station in this use case is a small cell, and a CBU is used for MBH, and an SFU is used for WLAN AP only.

The PON solution can use one of several mechanisms for frequency and time/phase synchronization as described in 6.2. The ONU types supporting MBH service backhaul in this solution, include the CBU, the SFP(+) ONU, and the SBU.

For the WLAN AP transport services, the PON system will typically provide GE or Fast Ethernet (FE) interfaces when 802.11n is used for the WLAN AP. The typical ONU type for WLAN AP service transport is SFU/HGU. In some co-location scenarios, WLAN APs use the Ethernet interfaces of the CBU.

5.4.2 Deployment Context

In some areas, there are requirements for small cells and public WLAN AP hotspots used to offload macrocells and access blind spots (especially indoors). Small cell backhaul service and WLAN AP transport service can be provided simultaneously by a PON port. Operators find that providing both MBH and WLAN AP transport over the same PON port is cost-efficient and easy-to-do. The CBU, SFP(+) ONU and SFU/HGU are to be deployed located in an indoor environment.

An SFP(+) ONU can be deployed when the small cell equipment supports an SFP(+) interface with both data and synchronization functions.

5.4.3 ONU Details

The CBU is expected to have several form factors.

1. A mini ONU with one GE port and one 1PPS+TOD interface suitable for inserting within a lamppost pillar
2. An SFP or SFP+ ONU that can be inserted into other units, e.g., base station equipment.
3. At least 2 GE ports are required for the very ONU carrying both MBH and WLAN AP services.
4. An MBU can be used in some scenarios to accommodate more small cells and WLAN APs.

The SFU type ONU can be an Ethernet only device. The SFU provides one or multiple GE or FE interfaces for WLAN AP transport service.

5.4.4 Other Considerations

For the MBH+W use case, the backhaul bandwidth and L2 QoS mechanism are configured to ensure the proper QoS of mobile and WLAN AP services in PON system.

5.5 Mobile Backhaul + WLAN AP + Residential (MBH + W + R)

5.5.1 Use Case Overview

5.5.1.1 Primary Motivation

The MBH + W + R use case addresses the situation where MBH, WLAN AP, and residential access services are all delivered over one PON port.

5.5.1.2 Figure

The MBH + W + R use case is illustrated in Figure 6. The same GE interface supports delivery of user traffic together with SyncE and PTP.

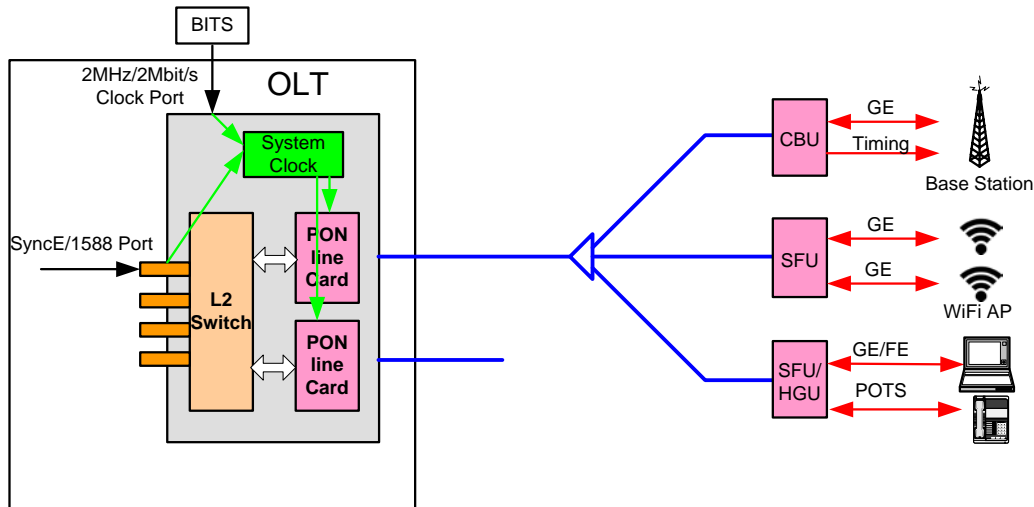

Figure 6 – PON port providing MBH, WLAN AP and residential services

5.5.1.3 Use Case Description

OLT PON ports can be used to deliver mobile backhaul service, WLAN AP transport and residential services simultaneously. The typical residential service is GE or FE, and POTS. Given that IEEE Std 802.11n and 802.11ac deployed, the typical WLAN AP transport service needs a GE interface. The typical residential services include GE, FE, and POTS. In some special situations, one CBU provides MBH, and WiFi services simultaneously.

At the ONU, for the mobile base station both the data channel and the timing signal are provided, for WLAN AP GE is provided, and for residential services GE/FE +POTS are provided. Normally, the base station is a small cell, and a CBU is used for MBH, an SFU is used for WLAN AP, and an SFU or a HGU is used for residential services.

The PON solution can use one of several mechanisms for frequency and time/phase synchronization as described in 6.2. The required ONU types needed to support this use case include the CBU, the SFP(+) ONU, the HGU ONU, and the SBU.

For the WLAN AP service, the ONU will provide GE or FE interfaces. The typical ONU type for WLAN AP services is an SFU. In some co-location situations, WLAN APs use the Ethernet interfaces of an existing CBU.

For residential subscriber triple-play services, the PON solution provides Ethernet, VoIP, and multicast functionalities with necessary QoS guarantees. The typical ONU types for residential subscribers are the SFU and the HGU. For the residential applications where an HGU is used, a WiFi radio interface is integrated in HGU device to provide indoor WiFi service. The WiFi integrated in the HGU has no special requirements.

5.5.2 Deployment Context

In some urban residential areas, there is demand for small cells and public WLAN APs used to offload macrocells and access blind spots (especially indoors) as well as for home access services.

Small cell backhaul service and WLAN AP services are provided, together with residential access, by PON systems. Operators find that providing MBH, WLAN AP, and residential access services over the same PON port is cost-efficient and easy-to-do. The CBU, SFP(+) ONU and SFU/HGU are deployed in an indoor environment.

An SFP(+) ONU can be deployed when the small cell equipment supports SFP(+) interface with both data and synchronization functions.

5.5.3 ONU details

The CBU is expected to have several form factors.

1. A mini ONU with one GE port and one 1PPS+TOD interface suitable for inserting within a lamppost pillar.
2. An SFP or SFP+ ONU that can be inserted into other units, e.g., base station equipment.
3. A MBU can be used in some scenarios.

The SFU type ONU has two possible form factors.

1. Ethernet only. The SFU provides one or multiple GE or FE interfaces for residential and WLAN AP services.
2. Ethernet + Voice. The SFU provides one or multiple GE or FE interfaces for residential and WLAN AP services, as well as a POTS interface for residential voice service.

The HGU type ONU provides multiple GE or FE interfaces for residential and WLAN AP services, as well as WiFi and POTS interfaces for residential wireless and voice services.

5.5.4 Other Considerations

For the MBH+W+R scenario, the bandwidth and L2 QoS mechanism are configured to guarantee mobile, WLAN AP, VoIP, and video services' QoS in PON system.

For residential, L2 multicast functions are necessary for IPTV service. IGMP/MLD proxy and snooping are supported in the OLT and ONU, respectively.

5.6 Mobile Backhaul + Business + Residential (MBH + B + R)

5.6.1 Use Case Overview

5.6.1.1 Primary Motivation

The MBH + B + R use case enables the simultaneous delivery of services to mobile backhaul, business and residential subscribers in the same geographic area, using the same PON port.

5.6.1.2 Figure

The MBH + B + R use case is illustrated in Figure 7. The same GE interface supports delivery of user traffic together with SyncE and PTP.

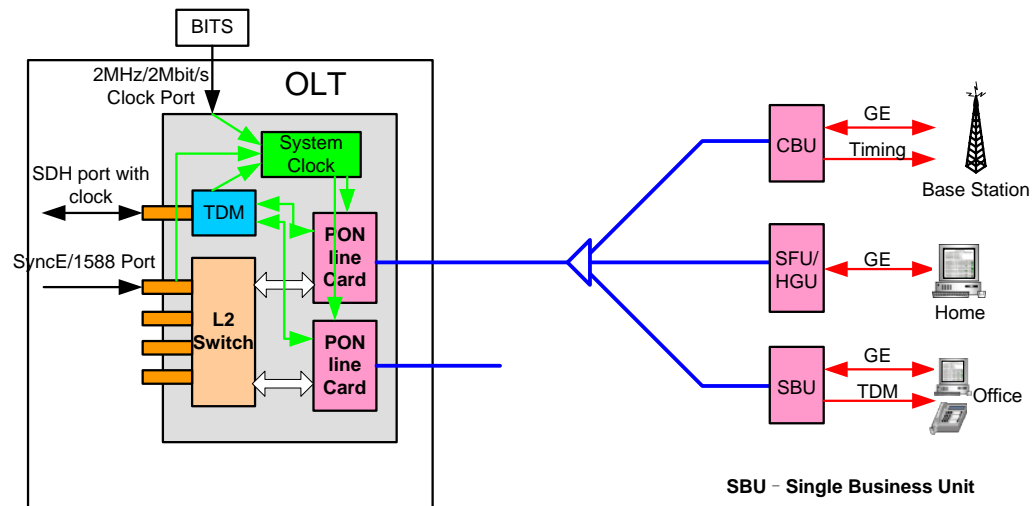

Figure 7 – PON System providing MBH, residential and business services simultaneously

5.6.2 Use Case Description

The OLT PON ports are able to support the simultaneous delivery of services to mobile, residential and business subscribers. The PON solution can use one of several mechanisms for frequency and time/phase synchronization as described in 6.2.

At the OLT, time/phase information (Precision Timing Protocol – PTP) can be delivered through the PON port to the specific UNI port (1PPS+TOD).

5.6.3 Deployment Context

MBH services can be deployed on existing PONs and planned PON deployments for other services in each geographic area.

Low power small cells can be combined with high power macro-cells to form a heterogeneous network. Phase and frequency synchronisation is critical. The heterogeneous network requires management techniques to increase efficiency through power and interference management including the following.

- Enhanced Inter-Cell Interference Co-ordination.
- Coordinated MultiPoint transmission (COMP).

The CBU can be deployed within a lamppost pillar for urban environments.

5.6.4 CBU Details

The CBU is expected to have several form factors.

1. A mini ONU with one GE port suitable for inserting within a lamppost pillar.
2. SFP ONU that can be inserted into other units, e.g., base station equipment.

3. An MBU can be used in some scenarios.

The CBU could be environmentally hardened according to local specifications and regulations.

6 Mobile System's Generic Requirements for Backhaul System

6.1 Bandwidth

Mobile backhaul bandwidth requirements are determined by a number of factors.

- Number of sectors per cell.
- Channel bandwidth per sector (MHz).
- Use of multiple input, multiple output (MIMO) technology.
- Use of internet protocol security (IPsec) and backhaul packet sizes.
- Use of carrier aggregation (LTE-advanced).
- Statistical multiplexing gain (if backhauling multiple cells and/or multiple sectors).

For small cells, only a single sector is used. The 3GPP standard specifies a maximum air interface bandwidth of 150Mbit/s for a single carrier LTE 20MHz 2x2 MIMO, which is supported in today's devices. A 4x4 MIMO, supported in 3GPP R9, doubles this bandwidth to 300Mbit/s. Carrier aggregation similarly doubles the bandwidth for two 20MHz carriers supported (as specified in R10 and R11). The 3GPP standards do not specify bandwidth requirements for use of IPsec or average packet sizes as this is dependent on operator choice and user behavior. As an example, for single carrier LTE 20MHz 2x2 MIMO with use of internet protocol security (IPsec), a total peak backhaul bandwidth of 175 Mbit/s is recommended.

The backhaul bandwidth for a small cell is depended on spectrum, sectors, MIMO parameters etc.

6.2 Synchronization

Low power small cells can be combined with high power macro-cells to form a heterogeneous network. Phase and frequency synchronization is critical.

In 3GPP standards, synchronization requirements were specified as end-to-end limits, as listed in Table 1, Table II.1 and Table II.2 in ITU-T G.8271.

Table 2 – Synchronization requirements of typical mobile systems

	Frequency	Phase	
UMTS 3G	+/- 50ppb	Not required	
LTE FDD	+/- 50ppb	Not required	R8
LTE TDD	+/- 50ppb	+/-1us to 5us	R8
eMBMS	+/- 50ppb	+/-1us	R9
Network MIMO	+/- 50ppb	+/-0.5us	R10/R11 (LTE-advanced)
ICIC	+/- 50ppb	+/-1us	R8

Coordinated MultiPoint transmission (COMP)	+/- 50ppb	+/-0.5us	R10/R11 (LTE-advanced)
Location Service	+/- 50ppb	+/-0.2us	R9

Work is being finalized within the ITU to apportion the end-to-end synchronization allocation (see Table 2) to the respective network segments including the access network and the base station. The allocation of time error budget to the access network including models for time allocation budgeting in a chain of PON devices is expected to be specified in ITU-T G.8271.1 [20] Amendment 3². G.8273.2 [21] Appendix V contains budgeting for a pair of transparent boundary clock.

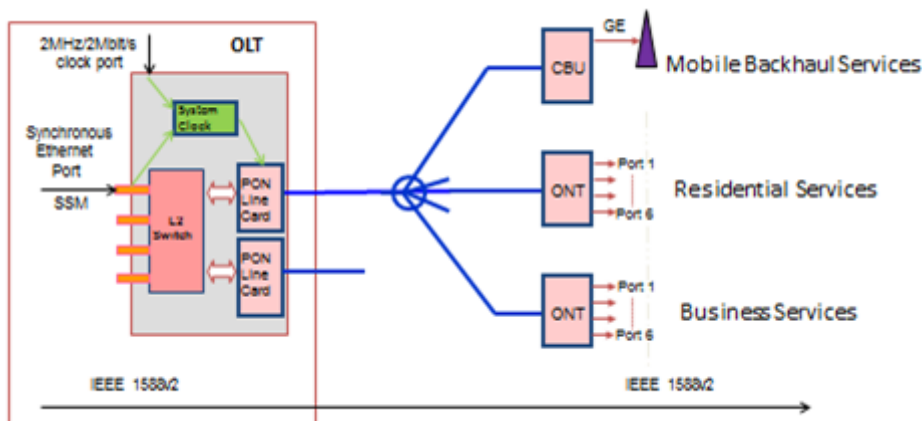

Figure 8 – Synchronization Architecture for Mobile Backhaul

As shown in Figure 8, the PON solution can use any one of several synchronization mechanisms for frequency and time/phase including the following.;

- BITS,
- 2MHz/2Mbit/s clock interfaces of ITU-T G.703 [9] ,
- Synchronous Ethernet,
- PTP
- GPS interface.

At the OLT time/phase information can be delivered using PTP over SyncE, on a dedicated port or on a traffic port.

The PON solution needs to comply with the frequency and time/phase requirements in the G.8271.1, G.8273.2 and G.8275 [22] series recommendations to ensure the frequency and time/phase information are transported correctly to maintain timing integrity and make use of the integrated timing capabilities to give the best timing performance with minimal accumulated error.

[R-1] PON system MUST support transfer of time and phase information by the boundary clock mode defined in ITU-T G.8271.1 [20].

² ITU-T G.8271.is planned for consent in 2017.

[R-2] PON system SHOULD support transfer of time and phase information by the transparent clock mode defined in ITU-T G.8271.1 [20].

[R-3] The time offset SHOULD be less than $\pm 100\text{ns}$ between OLT and ONUs in a given time of period specified by the network operator.

6.3 Delay

Delay recommendations for mobile networks are specified in 3GPP TS 23.203. As shown in Figure 9, a subset of the end-to-end performance budget is allocated to the backhaul network between the radio base station and the Policy Charging Enforcement Function (PCEF) which is usually at the same location as the packet data network gateway.

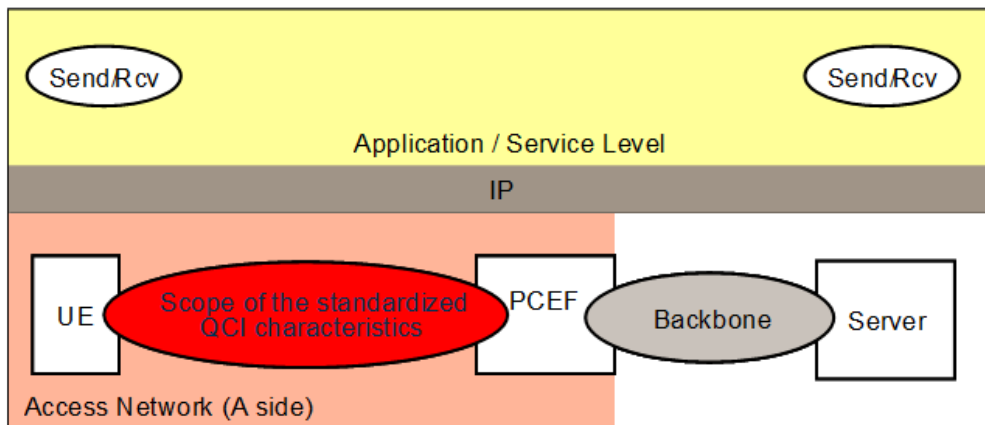

Figure 9 – Scope of the standardized QCI characteristics for client/server communication

The standard specifies an average of 20 ms one-way delay allocation for the backhaul. This is the average between the case where the PCEF is located close to the radio base station (roughly 10ms) and the case where the PCEF is located far from the radio base station, e.g., in the case of roaming with home routed traffic (the one-way packet delay between Europe and the US West coast is roughly 50ms). It is recommended that the PON backhaul solution is designed and provisioned to achieve the minimum 10ms delay figure.³

The backhaul allocation for LTE-advanced is being developed within the 3GPP standards but is expected to be 5ms. The delay budget for the PON segment of the network when used for tight radio coordination (e.g., enhanced Inter-Cell Interference Co-ordination, Coordinated MultiPoint transmission (COMP), etc.) needs to fit within the end to end expectation of about 2-4ms. For example, each PON segment budget might be <1ms. For information, see MEF 22.2 [34] Section 12.4.

³ See note 1 in Table 6.1.7 of 3GPP TS 23.203 version 10.9.0 Release 10

6.4 Traffic Management

The PON based MBH network needs to implement appropriate traffic management methods to achieve the following goals (refer to TR-156 [2]).

- Efficient use of bandwidth resources and unallocated bandwidth among traffic classes. The bandwidth requirement of MBH services as mentioned in clause 6.1 needs to be guaranteed, each UNI of the ONU needs to be granted with the bandwidth required by the specific eNB (i.e., minimal 150Mbps downstream and 50Mbps upstream assuming 20MHz bandwidth carrier for conventional eNB, less for small cells).

To efficiently use the bandwidth resources, the backhaul solution provides peak/average bandwidth in a flexible and granular way, thus the OLT sets the proper bandwidth allocation parameters for each ONU to satisfy the bandwidth requirement. The OLT and ONU support a minimal bandwidth granularity of 2Mbps as the NGMN Optimised Backhaul Requirements whitepaper [48] requires.

- Provide a forwarding class that can support end to end class of service (CoS) of MBH traffic. To maintain the higher priority of MBH services when hybrid services are carried by the PON system, the eNB / access gateway (aGW) Transport Module marks different MBH traffic with different CoS markings.

The PON System does not modify the original CoS markings from the eNB/aGW Transport Module, and uses the proper VLAN (see 802.1Q [41]) configuration to maintain the end to end CoS. This configuration is compatible with the operator's existing network VLAN configuration in a brown field scenario.

Typically, there are three major VLAN configurations for PON-based mobile backhaul traffic management: per Service/per VLAN, per User/per VLAN, and per User/per Service/per VLAN.

1. For the per Service/per VLAN configuration, the PON system marks different services with different customer VLAN, and can use a service VLAN to identify different uplink destinations.
2. For the per User/per VLAN configuration, the PON system marks each individual ONU with different customer VLAN within the scope of a single OLT chassis, and uses a service VLAN to identify the OLT chassis, which is compatible with typical residential service configuration.
3. For the per User/per Service/per VLAN configuration, the PON system uses customer VLAN to identify individual ONU within the scope of a single OLT chassis, and different service VLANs are used to marking different MBH services. Both services and users (ONUs) can both be distinguished by this VLAN implementation.

The particular VLAN implementation depends on the detailed end to end CoS requirements and operator's specific existing VLAN configuration.

6.5 OAM

Different backhaul PON technologies require different OAM protocols for managing and maintaining CBU equipment, CBU uplink interface, performance monitoring, etc. For ITU-T PONs, e.g., ITU-T G.984.4 [29], ITU-T G.988 OMCI [31] is used for normal remote OAM functions. For IEEE802.3 PONs, (i.e., 1G-EPON and 10G-EPON) OAM/extended OAM is used for normal remote OAM functions.

Configuring service interfaces which are independent from PON protocols, another protocol (e.g., SNMP, TR-069 [1]) is used, which is beyond the scope of TR-331.

[R-4] If the backhaul technology is IEEE802.3 [43] 1G-EPON or 10G-EPON the CBU MUST support being managed via the OLT using standard OAM and extended OAM functions specified in IEEE Std 802.3, Clause 57 and IEEE Std 1904.1 [39],.

[R-5] Extended OAM is an extension and enhancement of standard OAM using the organization-specific extension mechanism specified in IEEE Std 1904.1 [39], Clause 13 and 14, in which the protocol data unit format, message procedures, attributes and other details of extended OAM are defined.

[R-6] If the backhaul technology is ITU-T PON of G.984/G.987/G.9807 series, the CBU MUST support ITU-T G.988 clause 9.1, and 9.2.

6.6 Resiliency

For MBH networks, implementation of protection mechanisms is recommended to achieve availability targets. In particular, for PON-based backhaul networks, it is desirable that the service availability be 99.99% (understood as mobile connectivity continuity).

In the 3GPP TS 23.203 Policy and charging control architecture, the packet delay budget, from user equipment to PCEF, is specified as shown in Table 3.

Table 3 – Packet delay budget considerations

QCI	Resource Type	Priority Level	Packet Delay Budget	Packet Error or Loss Rate	Example Services
1	Guaranteed bit rate	2	100 ms	10^{-2}	Conversational Voice
2		4	150 ms	10^{-3}	Conversational Video (Live Streaming)
3		3	50 ms	10^{-3}	Real Time Gaming
4		5	300 ms	10^{-6}	Non-Conversational Video (Buffered Streaming)
65		0.7	75 ms	10^{-2}	Mission Critical user plane Push To Talk voice (e.g., MCPTT)
66		2	100 ms	10^{-2}	Non-Mission-Critical user plane Push To Talk voice
5	Non-guaranteed bit rate	1	100 ms	10^{-6}	IMS Signalling
6		6	300 ms	10^{-6}	Video (Buffered Streaming) TCP-based (e.g., www, e-mail, chat, ftp, p2p file sharing, progressive video, etc.)
7		7	100 ms	10^{-3}	Voice, Video (Live Streaming) Interactive Gaming
8		8	300 ms	10^{-6}	Video (Buffered Streaming) TCP-based (e.g., www, e-mail, chat, ftp, p2p file sharing, progressive video, etc.)
9					
69		0.5	60 ms	10^{-6}	Mission Critical delay sensitive signalling (e.g., MC-PTT signalling)
70		5.5	200 ms	10^{-6}	Mission Critical Data (e.g., example services are the same as QCI 6/8/9)

When employing PON to carry MBH traffic, those values in Table 3 provide guidance on the performance of employed protection schemes, i.e., interruption time. The interruption time is the time period between the time when service becomes blocked by a link failure, and the time when services are finally restored. In general, the interruption time is limited by the packet delay budget values given in Table 3. During the interruption time, behaviors include failure detection, protection scheme triggering, and service restoration.

To guarantee a certain quality of experience, it is recommended that PON networks limit the magnitude of such allowed interruption times below the respecting packet delay budget for each QCI level in Table 3, as the packet delay budget is suggested to be larger than the combination of interruption time plus other delay facts of the system as line transmission delay etc.

6.7 Other Requirements

[R-7] PON System SHOULD support JUMBO frame sizes of no less than 9000 bytes.

[Note: IEEE Std 802.3 defines the MTU for 10G EPON is 2000 bytes. ITU-T G.987.1 [30] defines JUMBO size from 2001-9000 bytes.]

7 Nodal Technical Requirements for PON Systems

7.1 Requirements for OLT Equipment

7.1.1 Interfaces

OLT transmits data traffic and frequency/phase synchronization signal via Ethernet interfaces and clock interfaces.

[R-8] The OLT MUST support uplink receive and transmit rates of at least 10 Gbps or better.

[R-9] The OLT MUST support a Synchronous Ethernet interface to receive frequency synchronization signal. The following methods MAY also be supported.

- 2 MHz/2Mbit/s (BITS) supporting ITU-T G.703 [9].
- GPS (1pps+ToD).
- PTP over GE/10GE.

[R-10] The OLT MUST support at least one of the following interfaces to receive time/phase synchronization signal.

- GPS (1pps+ToD).
- PTP over GE/10GE.

7.1.2 Synchronization Requirements (Frequency and Phase)

The OLT receives frequency information and time/phase information from uplink interfaces and delivers this information to the ONU via the PON port.

[R-11] The OLT MUST be able to derive and recover the frequency synchronization signal from the uplink Synchronous Ethernet interface. Outside clock interfaces such as GPS and BITS MAY also be supported.

[R-12] The OLT MUST use frequency information from the uplink interfaces as PON port line frequency clock when transmitting traffic to ONU.

[R-13] The OLT MUST support prioritization configuration of the frequency or time/phase signal sources when the OLT can derive the frequency or time/phase synchronization signal from more than one signal source.

[R-14] The OLT MUST be able to derive and recover the time/phase synchronization signal from the uplink Ethernet interfaces. An ITU-T G.8265 [18] or 1pps+ToD interface MAY also be supported.

[R-15] The OLT MUST support boundary clock or transparent clock mode specified in ITU-T G.8275.1 [23] to deliver time/phase synchronization signal via PON port to ONU.

7.1.3 Traffic Management (VLAN, QoS, etc.)

[R-16] The OLT MUST NOT modify or remark the QoS/CoS priority marked by eNB/aGW Transport Module.

[R-17] The OLT MUST support traffic flow VLAN tagging, stacking and translation in the per Service/per VLAN mode to maintain the end to end QoS/CoS differentiation and consistency.

[R-18] The OLT SHOULD support traffic flow VLAN tagging, stacking and translation in the per User/per VLAN mode to maintain the end to end QoS/CoS.

[R-19] The OLT SHOULD support traffic flow VLAN tagging, stacking and translation in the per User/per Service/per VLAN mode to maintain the end to end QoS/CoS.

[R-20] The OLT MUST support eight QoS/CoS markings for MBH services.

[R-21] The OLT SHOULD support mapping between L2 layer QoS marking and IP layer CoS marking.

[R-22] The OLT MUST support configuration of bandwidth allocation parameters for ONUs with a minimal bandwidth granularity of 2Mbps.

[R-23] The OLT MUST support shaping per VLAN and groups of VLANs.
The OLT MUST support shaping of both individual VLANs and on groups of VLANs.

7.1.4 Multicast

[R-24] The OLT MUST support multicast protocols and IGMP/MLD capabilities according to BBF TR-178 [3] and TR-221 [4].

[R-25] The OLT MUST support VLAN manipulations on multicast services according to BBF TR-178 [3] and TR-221 [4].

7.1.5 OAM

The OLT supports Ethernet Link OAM, when the user is directly connected to the network demarcation point. Link OAM provides OAM functions for network access segments. Link OAM provides for Ethernet Link Fault Detection, Monitoring and Loopback for access links.

The following requirements apply to OLTs.

[R-26] The OLT SHOULD support rate limiting of received connectivity fault management (CFM) Ethernet OAM messages per IEEE Std 802.1ag [47] arriving on all supported maintenance levels as per IEEE Std 802.3 [43] Clause 30.3.1.1.38.

[R-27] The OLT MUST support link OAM requirements specified in TR-224 [5] section 8.1.1 [R-10] – [R-16].

7.1.6 Resiliency

[R-28] The OLT MAY support protection of uplink interfaces through VRRP per RFC 5798 [36] and BFD per RFC 5880 [37].

[R-29] The OLT MUST support uplink interface resiliency through Link Aggregation Control Protocol (LACP) per IEEE Std 802.3ad. The LACP function MUST be able to be enabled when implementing S-VLAN in the northbound interfaces. The LACP function MUST support both scenarios: uplink northbound interfaces distributed in one uplink card, or in multi uplink cards.

[R-30] The OLT SHOULD support Type B or Type C protection scheme (GPON per ITU G.984.1 [25] , or EPON per SIEPON IEEE 1904.1 [39]), with associated fast PON failure restoration schemes to enable protection switch when detecting failure trigger conditions.

[R-31] While operating with protection schemes, the OLT SHOULD: monitor the link status, implement protection switching when failure trigger condition has been detected, and switch back when failed link is restored. The interruption time SHOULD be less than 100ms, and is preferred to be within 50ms.

7.2 Requirements for ONU Equipment

7.2.1 Interfaces

The ONU receives frequency and time/phase information from the PON port and delivers this information to the UNI interface.

[R-32] The ONU MUST support at least one of the following UNI interfaces to receive and transmit data traffic.

- FE interface.
- GE interface. A device MAY support electrical interfaces, optical interfaces or both.

[R-33] The optional GE interface on an ONU MUST support Synchronous Ethernet for delivery of the frequency synchronization signal to the base station.

[R-34] The ONU MAY optionally support one of the following methods for delivery of the frequency synchronization signal to the base station.

- PTP over FE/GE.
- 2MHz/2Mbit/s interface supporting ITU-T G.703 [9].

[R-35] The ONU MUST support at least one of the following UNI interfaces to deliver time/phase synchronization to the base station.

- PTP over FE/GE.⁴⁵
- 1pps+ToD interface.

[R-36] The ONU SHOULD support shaping per VLAN and groups of VLANs.

The ONU SHOULD support shaping of both individual VLANs and on groups of VLANs.

7.2.2 Synchronization Requirements (Frequency and Phase)

The ONU receives frequency information and time/phase information from PON port, and delivers this information to the base station.

[R-37] The ONU MUST be able to derive and recover the frequency synchronization signal from the PON port.

[R-38] The OLT MUST be able to deliver frequency synchronization information from PON port to the base station via UNI interfaces.

[R-39] The ONU MUST be able to derive and recover the time/phase synchronization signal from the PON port.

[R-40] The ONU MUST be able to act as the master clock to deliver time/phase synchronization information recovered from the PON port to the base station.

7.2.3 Traffic Management (VLAN, QoS, etc.)

[R-41] The ONU MUST NOT modify or remark the QoS/CoS priority marked by eNB/aGW Transport Module.

[R-42] The ONU SHOULD support traffic flow VLAN tagging and translation using the per User/per VLAN mode.

[R-43] The ONU SHOULD support traffic flow VLAN tagging and translation using the per User/per Service/per VLAN mode.

⁴ The performance of carrying PTP over interfaces below GE is for further study.

⁵ The partial timing support profile (G.8275.2) is also available but clocks and network performance are still under development.

[R-44] The ONU MAY support VLAN stacking using the per User/per Service/per VLAN mode.

[R-45] The ONU MUST support eight QoS/CoS markings for MBH services.

[R-46] The ONU SHOULD support mapping between L2 layer QoS marking and IP layer CoS marking.

7.2.4 Multicast

[R-47] The ONU MUST support multicast protocols and IGMP/MLD capabilities according to BBF TR-178 [3] and TR-221 [4].

[R-48] The ONU MUST support VLAN manipulations on multicast services according to BBF TR-178 [3] and TR-221 [4].

7.2.5 OAM

The ONU supports Ethernet Link OAM, when the user is directly connected to the network demarcation point. Link OAM provides OAM functions for network access segments. Link OAM provides for Ethernet Link Fault Detection, Monitoring and Loopback for access links.

The following requirements apply to ONUs.

The MEF Carrier Ethernet Services are provided between one UNI to one or more UNIs. A network operator can manage the services using Service OAM (SOAM)[5]. The network operator's service OAM is originated at the ONU UNI Network (UNI-N)[33]. For requirements on SOAM and UNI Network see [5] and [33].

[R-49] The ONU SHOULD support rate limiting of received connectivity fault management (CFM) per IEEE Std 802.1ag [47]. Ethernet OAM messages arriving on all supported maintenance levels as per IEEE Std 802.3 [43] Clause 30.3.1.1.38.

[R-50] The ONU MUST support link OAM requirements specified in TR-224 [5] section 8.1.1 [R-10] – [R-16].

[R-51] If the ONU supports MEF services, the ONU MUST support MEF service OAM requirements specified in TR-224 [5] section 8.1.2 [R-17] and [R-19].

7.2.6 Resiliency

[R-52] The ONU SHOULD support Type C protection scheme (GPON per ITU G.984.1 [25], or EPON per SIEPON 1904.1 [39]) with associated fast PON failure restoration schemes to enable protection switching when detecting failure trigger condition, and switching back

when failed link is restored. The interruption time follows requirement [R-31] in the section 7.1.6.

Appendix A. Some Implementation Guidelines

A.1 ODN Modeling

A.1.1 Comparison Between Point to Point ODN and PON-based ODN

The conventional point to point ODN structure used for MBH networks requires one to one mapping between the macro/small cells and trunk fibers, as shown in Figure 10. The scale and complexity of the ODN grows proportional to the number of macro/small cells, thus construction costs of the ODNs has little space for optimization. Moreover, it is hard to deploy macro/small cells in a “Pay as You Grow” way, as adding more cells in the future requires laying more trunk fibers, installing new cells and bringing them into service cannot be done in a short timeframe.

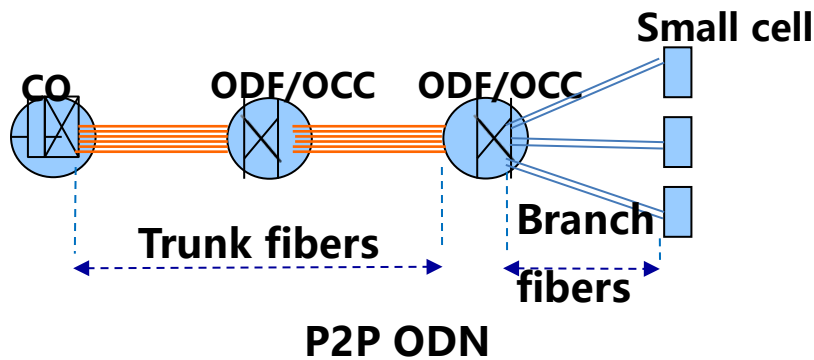

Figure 10 – Point to point ODN structure for MBH

For the PON-based ODN, the point to multi-point topology eliminates the necessity for one to one mapping between the macro/small cells and the trunk fibers. As shown in Figure 11, with the deployment of splitters, one trunk fiber can carry multiple branch fibers and thus multiple cells. The construction costs can be efficiently brought down, and “Pay as You Grow” capability can be adopted for the cells, since adding more cells only involves activating more branch fibers, and no additional trunk fiber is needed. The time required for installing and configuring cells can be greatly reduced.

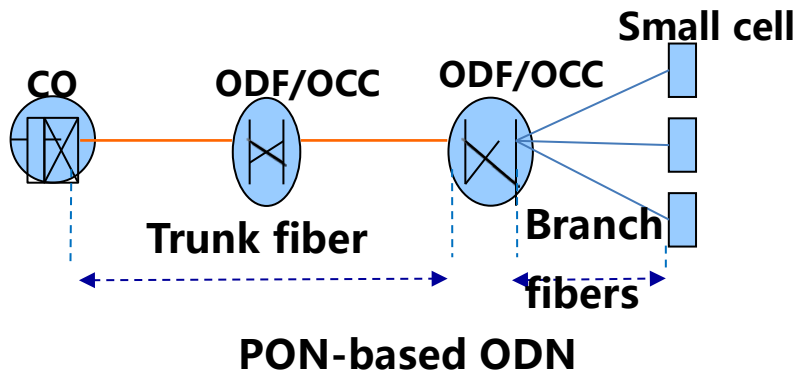

Figure 11 – PON-based point to multi-point ODN structure for MBH

A.1.2 ODN Modeling Discussion

A.1.2.1 General Discussion

PON-based MBH saves trunk fiber resources, reduces construction costs and allows faster service initialization. These benefits rely on the wide deployment of the PON ODNs. Mobile cells with PON CBUs can easily be installed as long as there is branch fiber nearby. The CBU can be connected to the existing ODN along with existing residential and business ONUs. Proper VLAN and QoS settings need to be configured on the OLT to ensure MBH service quality.

The PON-based ODN is mainly for small cell backhaul, as the bandwidth and resiliency requirements for the macro-cells are usually better fulfilled with the traditional point to point ODN structure.

To enhance the resiliency of the MBH services, the trunk fibers connecting the central office and the 1st stage splitter, typically located in the ODF of the office, can be deployed in a ring topology, as shown in Figure 12. Each 1st stage splitter can expand its coverage by several 2nd stage splitters.

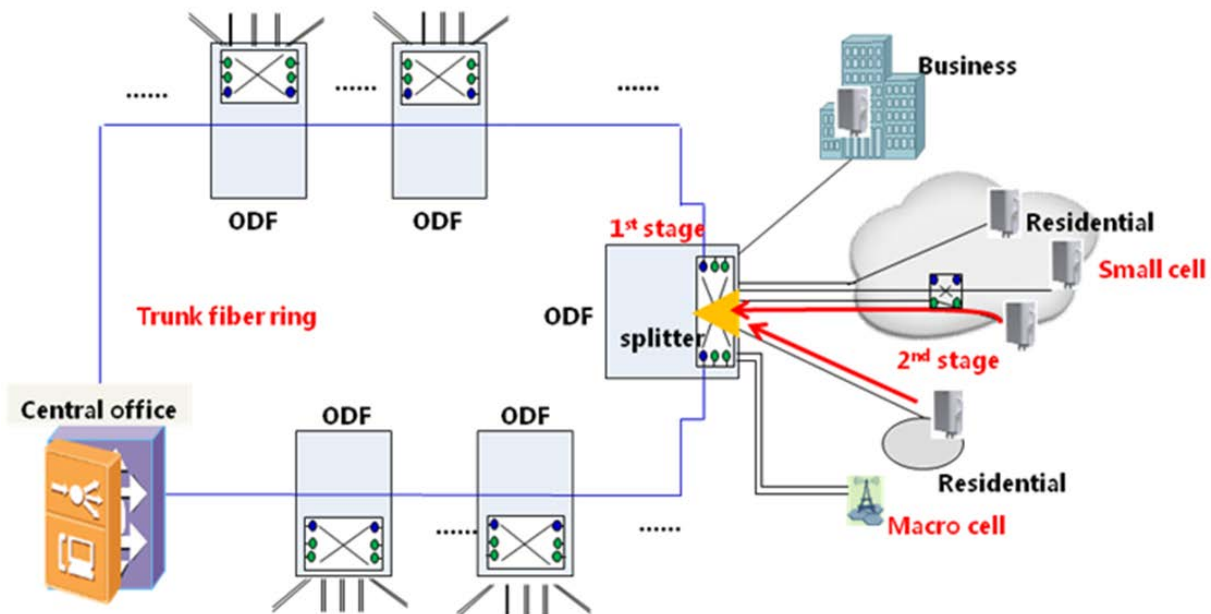

Figure 12 – Typical access ODN topology

A.1.2.2 Deployment Modeling

In the case when MBH services are carried by an existing ODN along with residential and/or business services, the splitting ratio of the ODN needs to be carefully considered, as the bandwidth requirements for MBH services are quite high. Inserting several small cells into an existing ODN can boost the overall bandwidth consumption; existing residential and business clients are not to be affected. The backhaul bandwidth parameters in Section 6.1 are to be taken into consideration when MBH services are deployed in existing ODNs.

Using an existing PON-based ODN can lower the cost of MBH service deployment. However, as the number of small cell increases, the splitting ratio and the total bandwidth of a single PON can become a bottleneck for the MBH services.

Deploying MBH services using a dedicated PON-based ODN is an alternative. If the number of small cells carried by a single PON exceeds a certain level (e.g., over 10), the total bandwidth of the PON can become a bottleneck for the small cells plus the existing residential or business clients.

In urban areas, a macro cell among several buildings can require several small cells nearby to cover the blind spots of the macro cell. In this scenario, all the small cells can be connected with a single 1st stage splitter.

In rural areas, a macro cell has wider coverage, to cover the blind spots, small cells usually have a much sparser distribution. Much longer branch fibers are needed if a single-stage splitter is used. The 2-stage ODN structure can save the branch fiber lengths in this circumstance. The 1st stage splitter in the ODN can have several 2nd stage splitters connected, and the small cells are connected to these 2nd stage splitters. A much wider coverage can be achieved without significant branch fiber consumption.

End of Broadband Forum Technical Report TR-331