

TR-300

Policy Convergence for Next Generation Fixed and 3GPP Wireless Networks

Issue: 1
Issue Date: September 2014

Notice

The Broadband Forum is a non-profit corporation organized to create guidelines for broadband network system development and deployment. This Broadband Forum Technical Report has been approved by members of the Forum. This Broadband Forum Technical Report is not binding on the Broadband Forum, any of its members, or any developer or service provider. This Broadband Forum Technical Report is subject to change, but only with approval of members of the Forum. This Technical Report is copyrighted by the Broadband Forum, and all rights are reserved. Portions of this Technical Report may be copyrighted by Broadband Forum members.

THIS SPECIFICATION IS BEING OFFERED WITHOUT ANY WARRANTY WHATSOEVER, AND IN PARTICULAR, ANY WARRANTY OF NONINFRINGEMENT IS EXPRESSLY DISCLAIMED. ANY USE OF THIS SPECIFICATION SHALL BE MADE ENTIRELY AT THE IMPLEMENTER'S OWN RISK, AND NEITHER the Forum, NOR ANY OF ITS MEMBERS OR SUBMITTERS, SHALL HAVE ANY LIABILITY WHATSOEVER TO ANY IMPLEMENTER OR THIRD PARTY FOR ANY DAMAGES OF ANY NATURE WHATSOEVER, DIRECTLY OR INDIRECTLY, ARISING FROM THE USE OF THIS SPECIFICATION.

Broadband Forum Technical Reports may be copied, downloaded, stored on a server or otherwise re-distributed in their entirety only, and may not be modified without the advance written permission of the Broadband Forum.

The text of this notice must be included in all copies of this Broadband Forum Technical Report.

Issue History

Issue Number	Approval Date	Publication Date	Issue Editor	Changes
1	8 September 2014	27 October 2014	Bill Welch, Oracle Roberto David Carnero Ros, Ericsson	Original

Comments or questions about this Broadband Forum Technical Report should be directed to help@broadband-forum.org.

Editors	Bill Welch Roberto David Carnero Ros	Oracle Ericsson	william.welch@oracle.com roberto.david.carnero@ericsson.com
End to End Architecture WG Chairs	David Allan David Thorne	Ericsson BT	david.i.allan@ericsson.com david.j.thorne@bt.com
Vice Chair	Sven Ooghe	Alcatel-Lucent	sven.ooghe@alcatel-lucent.com

TABLE OF CONTENTS

EXECUTIVE SUMMARY	7
1 PURPOSE AND SCOPE	8
1.1 PURPOSE.....	8
1.2 SCOPE.....	8
2 REFERENCES AND TERMINOLOGY	10
2.1 CONVENTIONS	10
2.2 REFERENCES	10
2.3 DEFINITIONS.....	12
2.4 ABBREVIATIONS.....	13
3 TECHNICAL REPORT IMPACT	15
3.1 ENERGY EFFICIENCY	15
3.2 IPV6	15
3.3 SECURITY	15
3.4 PRIVACY.....	15
4 USE CASES FOR POLICY CONVERGENCE	16
4.1 SHARED DATA PLAN	16
4.2 NEXT HOP CHANGE BASED ON POLICIES.....	16
5 REFERENCE ARCHITECTURE	18
5.1 REFERENCE ARCHITECTURE DIAGRAMS	18
5.2 NETWORK ENTITIES	19
5.2.1 PCRF.....	19
5.2.2 PCEF	19
5.2.3 AF.....	19
5.2.4 OCS	19
5.2.5 OFCS.....	20
5.2.6 AIF.....	20
5.3 REFERENCE POINTS	20
5.3.1 Rx Reference Point	21
5.3.2 Gx Reference Point.....	21
5.3.3 Charging Reference Points	22
5.3.4 STa Reference Point	22
6 POLICY CONTROL AND CHARGING REQUIREMENTS	24
6.1 GENERAL REQUIREMENTS.....	24
6.1.1 Session Mapping Requirements	25
6.1.2 Event Triggers and Credit Reauthorization Triggers	27
6.2 REQUIREMENTS FOR QoS CONTROL	28
6.2.1 QoS Information Elements	28
6.2.2 Admission Control.....	30
6.2.3 Information Elements of Default QoS	30

6.3	REQUIREMENTS FOR CHARGING CONTROL.....	31
6.3.1	<i>Charging Control Information Elements</i>	31
6.3.2	<i>Architecture based on 3GPP Gy/Gz Interfaces</i>	32
6.3.3	<i>AAA based Charging</i>	33
6.4	USAGE MONITORING.....	34
6.5	PCRF DISCOVERY.....	35
6.5.1	<i>PCEF in the MS-BNG – PCRF Discovery</i>	36
7	PROCEDURES	37
7.1	IP-CAN SESSION ESTABLISHMENT	37
7.2	IP-CAN SESSION TERMINATION	37
7.3	IP-CAN SESSION MODIFICATION.....	37
	APPENDIX I. PREFIX SHARING ISSUE.....	38

List of Figures

Figure 1 – Converged Policy and Charging Control for Shared Data Plan	16
Figure 2 – Flow-based action based on the 5-tuple.....	17
Figure 3 – Architecture for Gy/Gz based accounting architecture.....	18
Figure 4 – Architecture for AAA-based accounting	18
Figure 5 – Fixed Broadband Domain Elements and Interfaces.....	20
Figure 6 – Logical Binding of Subscriber IP Session and IP-CAN Session.....	26

List of Tables

Table 1 – Event triggers at Gx	28
Table 2 – Credit Reauthorization Triggers at Gy	28
Table 3 – QoS Information Elements of PCC rule.....	29
Table 4 – Charging rule information elements.....	32
Table 5 – Usage Monitoring Control related information.....	35

Executive Summary

The Broadband Forum, in cooperation with 3GPP, is developing architecture and solutions for the converged policy and charging management for wireline and wireless networks.

TR-300 builds mainly on the work done in TR-134c1 [3], TR-146 [6], TR-203 [8], TR-291 [10], 3GPP TS 23.203 [13] and 3GPP TS 23.402 [14], and provides the nodal requirements for BBF network entities for use cases described there in.

1 Purpose and Scope

1.1 Purpose

To provide cost-effective support for the growing use of multimedia applications and related traffic growth in both fixed and mobile environments, service providers are looking to solutions that constrain capital and operational expenditures. While network traffic continues to grow annually, it is unlikely to produce a commensurate increase in revenue in a competitive and regulated marketplace. Service providers owning both fixed and wireless access networks have the opportunity to consider converged solutions that provide optimization of the network infrastructure. At the same time, sharing Policy and Charging Control (PCC) components between fixed and wireless access facilitates the alignment of service offerings and end user experience across both types of access technologies.

In the scenario of a single service provider deploying both a fixed access network and a mobile access network, a converged policy and charging solution is an architecture option.

The purpose of this project is to adapt the Fixed Broadband architecture, mainly in the policy control and Authentication Authorization Accounting (AAA) areas, consistently with 3GPP architecture, in order to reach the convergence goals set by service provider.

However, although this Technical Report is focused on service providers with both fixed and wireless access, the requirements can also be used by fixed-only service providers, who want to ease interoperability of their broadband network elements with control plane elements, such as the Policy and Charging Rules Function (PCRF).

This Technical Report defines business requirements and a Converged Policy Management reference architecture to support extension of the BBF specifications that facilitate convergence with the 3GPP Evolved Packet Core network based on the 3GPP PCC architecture and interfaces. The solution has been developed in collaboration with 3GPP and it is complemented by the following 3GPP Rel-12 specifications: TS 22.278 [11] and TS 23.203 [13].

1.2 Scope

This Technical Report addresses the general and nodal requirements in the Fixed Broadband network in order to support a converged policy and charging architecture based on 3GPP PCC. While Policy interworking (TR-203 [8] and TR-291 [10]) can achieve some service convergence, by aligning the Broadband Policy Control Function (BPCF) and the PCRF over S9a interface, this document is focused on using a single PCRF instance across both fixed and wireless access.

The network elements involved include: Multi Service Broadband Network Gateway (MS-BNG), AAA, Policy Decision Point (PDP) – which, in the context of this Technical Report, is the PCRF – and User Equipment (UE).

The following topics are covered in this Technical Report:

Converged Quality of Service (QoS) policy control:

- Enhancement of the Gx based interface for QoS policy control between PCRF and MS-BNG.
- Enforcement of the policies received from the PCRF in the Fixed Broadband network.

Converged charging:

The following architecture options will be considered:

- Enhancement of Gy/Gz based interface between 3GPP charging system and the MS-BNG.
- AAA-based charging.

TR-300 takes into account the use cases and requirements defined in TR-134c1 [3] and TR-144 [4] and the use cases in TR-203 [8]. Additional use cases are considered in section 4.

TR-300 builds upon TR-124i3 [2], TR-134c1 [3], TR-146 [6], TR-178 [7], TR-203 [8], TR-242 [9] and TR-291 [10].

Note: The support of multicast is not included in TR-300 Issue 1.

Note: The support of TR-134c1 [3] Home Gateway use case is not part of TR-300 Issue 1.

Note: The support of Ethernet Sessions is not part of TR-300 Issue 1.

2 References and Terminology

2.1 Conventions

In this Technical Report, several words are used to signify the requirements of the specification. These words are always capitalized. More information can be found in RFC 2119 [17].

MUST	This word, or the term “REQUIRED”, means that the definition is an absolute requirement of the specification.
MUST NOT	This phrase means that the definition is an absolute prohibition of the specification.
SHOULD	This word, or the term “RECOMMENDED”, means that there could exist valid reasons in particular circumstances to ignore this item, but the full implications need to be understood and carefully weighed before choosing a different course.
SHOULD NOT	This phrase, or the phrase "NOT RECOMMENDED" means that there could exist valid reasons in particular circumstances when the particular behavior is acceptable or even useful, but the full implications need to be understood and the case carefully weighed before implementing any behavior described with this label.
MAY	This word, or the term “OPTIONAL”, means that this item is one of an allowed set of alternatives. An implementation that does not include this option MUST be prepared to inter-operate with another implementation that does include the option.

2.2 References

The following references are of relevance to this Technical Report. At the time of publication, the editions indicated were valid. All references are subject to revision; users of this Technical Report are therefore encouraged to investigate the possibility of applying the most recent edition of the references listed below.

A list of currently valid Broadband Forum Technical Reports is published at www.broadband-forum.org.

Document	Title	Source	Year
[1] TR-101i2	<i>Migration to Ethernet-Based Broadband Aggregation</i>	BBF	2011
[2] TR-124i3	<i>Functional Requirements for Broadband Residential Gateway Devices</i>	BBF	2012

[3]	TR-134c1	<i>Broadband Policy Control Framework</i>	BBF	2012
[4]	TR-144	<i>Broadband Multi-Service Architecture & Framework Requirements</i>	BBF	2007
[5]	TR-145	<i>Multi-service Broadband Network Functional Modules and Architecture</i>	BBF	2012
[6]	TR-146	<i>Subscriber Sessions</i>	BBF	2013
[7]	TR-178	<i>Multi-service Broadband Network Architecture and Nodal Requirements</i>	BBF	2014
[8]	TR-203	<i>Interworking between next generation fixed and 3GPP wireless access</i>	BBF	2012
[9]	TR-242	<i>IPv6 Transition Mechanisms for Broadband Networks</i>	BBF	2012
[10]	TR-291	<i>Nodal Requirements for Interworking between Next Generation Fixed and 3GPP Wireless Access</i>	BBF	2014
[11]	TS 22.278	<i>Service requirements for Evolved Packet System (EPC)</i>	3GPP	2013
[12]	TS 23.002	Network Architecture	3GPP	2013
[13]	TS 23.203	<i>Policy and charging control architecture</i>	3GPP	2013
[14]	TS 23.402	<i>Architecture enhancements for non-3GPP accesses</i>	3GPP	2013
[15]	TS 32.240	<i>Telecommunication management; Charging management; Charging architecture and principles</i>	3GPP	2013
[16]	TS 32.251	<i>Telecommunication management; Charging management; Packet Switched (PS) domain charging</i>	3GPP	2013
[17]	RFC 2119	<i>Key words for use in RFCs to Indicate Requirement Levels</i>	IETF	1997
[18]	RFC 3046	<i>DHCP Relay Agent Information Option</i>	IETF	2001
[19]	RFC 3633	<i>IPv6 Prefix Options for Dynamic Host Configuration Protocol (DHCP) version 6</i>	IETF	2003
[20]	RFC 4006	<i>Diameter Credit-Control Application</i>	IETF	2005

2.3 Definitions

The following terminology is used throughout this Technical Report.

3GPP UE	The 3GPP UE is defined in 3GPP TS 23.002 [12]. The 3GPP UE allows a 3GPP user the access to network services. For the purpose of this specification, the interface between the UE and the Fixed Broadband Network is the WLAN as defined in IEEE 802.11 together with the IEEE 802.1x authentication and the EAP-AKA' method.
Accounting Interworking function	The Accounting Interworking Function (AIF), placed at the Fixed Broadband AAA, interacts with both the 3GPP Online Charging System (OCS) via the Gya interface, and/or the Offline Charging System (OFCS) via the Gza interface. The B reference point transfers accounting information related to the Fixed device and to the BBF-routed traffic capable 3GPP UE from the MS-BNG to the Fixed Broadband AAA server.
Delegating router	In IPv6, a router that acts as a DHCP server or relay and is responding to the prefix requests (RFC 3633 [19]).
Flow	Per TR-146 [6], a grouping of traffic identified by a set of header information and port information including, but not limited to: IP header, Layer 2 (L2) Header, Virtual and/or Physical interface Port, and/or Agent Circuit ID information for a remote port in the access network.
Event Trigger	A trigger resulting from subscriber traffic matching a rule specifying the event reporting behavior of a Policy and Control Enforcement Function (PCEF). The rule defines the event(s) that causes a request for PCC Rules. It can be used for credit management events.
IP-CAN Session	The IP Connectivity Access Network (IP-CAN) Session is the association between a UE and an IP network. The association is identified by one IP address (v4 or v6) and/or an IPv6 prefix together with UE identity information, if available, and a Packet Data Network (PDN) represented by a PDN ID – e.g. an Access Point Name (APN). An IP-CAN Session exists as long as UE IP addresses/prefix are established and announced to the IP network. The IP-CAN Session is defined in the Annex S/3GPP TS 23.203 [13]. Note: An IP-CAN Session corresponds to an IP Session or Point-to-Point Protocol (PPP) Session in the context of TR-146 [6].
IP Flow	Per TR-146 [6], an IP Flow is identified by a 5-tuple IP parameter traffic classifier. An IP Flow identifier forms the classification element of a traffic policy that is applied to a subscriber session. The 5-tuple is made up of following header fields: source IP address, source port, destination IP address, destination port and protocol.
IP Session	Per TR-146 [6], an IP Session is a grouping of traffic according to one or more classifiers visible at a control point, called the IP Edge, in the broadband network. The classifier is composed of, at a minimum, a Subscriber's IP address (v4 or v6), IPv4 subnet or IPv6 prefix. Additional Layer1 and Layer 2 parameters may be part of the IP Session where appropriate.

Monitoring key	According to 3GPP TS 23.203 [13], it is the information used by the PCEF and the PCRF for usage monitoring control purposes. It identifies the monitoring and reporting of the usage threshold for input, output or total data volume for the IP-CAN Session or the flows' traffic associated with the same monitoring key.
Monitoring time	It defines the time at which the PCEF shall reapply the threshold value provided by the PCRF.
MS-BNG	Per TR-178 [7], the MS-BNG extends the capabilities of a traditional BNG to offer services to both residential and business customers as well as to allow mobile backhaul deployments. To achieve this, it performs Ethernet Aggregation and can either forward packets via Multiprotocol Label Switching (MPLS) or through IP Aggregation/routing. A MS-BNG is part of TR-145 [5] network architecture and can be deployed in a hierarchical BNG architecture.
Offline Charging	According to 3GPP TS 32.240 [15], it is a charging process where charging information does not affect, in real-time, the service rendered.
Online Charging	According to 3GPP TS 32.240 [15], it is a charging process where charging information can affect, in real time, the service rendered and therefore directly interacts with the session/service control.
Subscriber Session	Per TR-146 [6], a Subscriber Session is either a PPP Session, or an IP Session, or a layer Ethernet Session. Subscriber Sessions are used to represent all traffic that is associated with that subscriber by a given service provider in order to provide a context for policy enforcement application.

2.4 Abbreviations

This Technical Report uses the following abbreviations:

3GPP	Third Generation Partnership Project
AAA	Authentication, Authorization & Accounting
AIF	Accounting Interworking Function
AF	Application Function
AKA	Authentication and Key Agreement
AN	Access Node
ANCP	Access Node Control Protocol
APN	Access Point Name
ASP	Application Service Provider
ATM	Asynchronous Transfer Mode
BPCF	Broadband Policy Control Function
BSSID	Basic Service Set Identifier
DHCP	Dynamic Host Configuration Protocol
DRA	Diameter Routing Agent
EAP	Extensible Authentication Protocol
EPC	Evolved Packet System
ETS	Emergency Telecommunication Service
GBR	Guaranteed Bit Rate
ID	Identifier

IE	Informational Element
IMSI	International Mobile Subscriber Identity
IP-CAN	IP Connectivity Access Network
L2	Layer 2
MAC	Media Access Control
MPLS	Multiprotocol Label Switching
MS-BNG	Multi-Service Broadband Network Gateway
NAI	Network Access Identifier
NAT	Network Address Translation
NMS	Network Management System
NSP	Network Service Providers
NSWO	Non-Seamless WLAN Offload
OCS	Online Charging System
OFCS	Offline Charging System
OSS	Operations Support System
PCC	Policy and Charging Control
PCEF	Policy and Charging Enforcement Function
PCRF	Policy and Charging Rules Function
PDN	Packet Data Network
PDP	Policy Decision Point
PEP	Policy Enforcement Point
PPP	Point-to-Point Protocol
QCI	QoS Class Identifier
QoS	Quality of Service
RADIUS	Remote Authentication Dial-In User Service
RG	Residential Gateway
SSID	Service Set Identifier
STB	Set Top Box
TR	Technical Report
UE	User Equipment
VLAN	Virtual Local Area Network
WG	Working Group
WLAN	Wireless Local Area Network.

3 Technical Report Impact

3.1 Energy Efficiency

Converged Policy Management means the same PDP is used for both Fixed Broadband and 3GPP Mobile Broadband management. However, the Fixed Broadband Policy Enforcement Point (PEP), *i.e.* the MS-BNG, may consume more power by implementing PCEF functionalities.

3.2 IPv6

IPv6 is covered in this Technical Report. Both IPv4 address and IPv6 address/prefix assignment are considered in the nodal requirements related to IP-CAN Session binding, PCEF in the MS-BNG – PCRF discovery, and as part of the IP Session classifier.

3.3 Security

Security aspects for Policy are already described in Section 3.3/TR-134c1 [3].

3.4 Privacy

Privacy aspects for Policy are already described in Section 3.4/TR-134c1 [3].

4 Use cases for Policy Convergence

This section contains use cases that describe the needs of service providers for Policy Convergence. TR-134c1 [3] and TR-203 [8] provide a set of use cases that are in TR-300 scope (see section 1.2). Only use cases that are not covered by those Technical Reports and that are applicable for Policy Convergence are described in this section.

4.1 Shared Data Plan

A family has three mobile data plans, attached to three different 3GPP UEs, plus a fixed broadband subscription provided by the same service provider. As part of their mobile data plans subscription, they share the same data allowance by the three 3GPP UE devices. The same subscription might allow the users to include the fixed broadband service allowance as part of the shared plan. This works for either pre-paid or post-paid subscriptions. The service allowance quota or charging rate could be flexible as part of the shared plan. This subscription model requires real-time usage control and charging information to be provided seamlessly to the service provider for both the accesses types.

This use case would take advantage of a same control infrastructure (policy and charging) independently of the access network. Figure 1 represents that scheme.

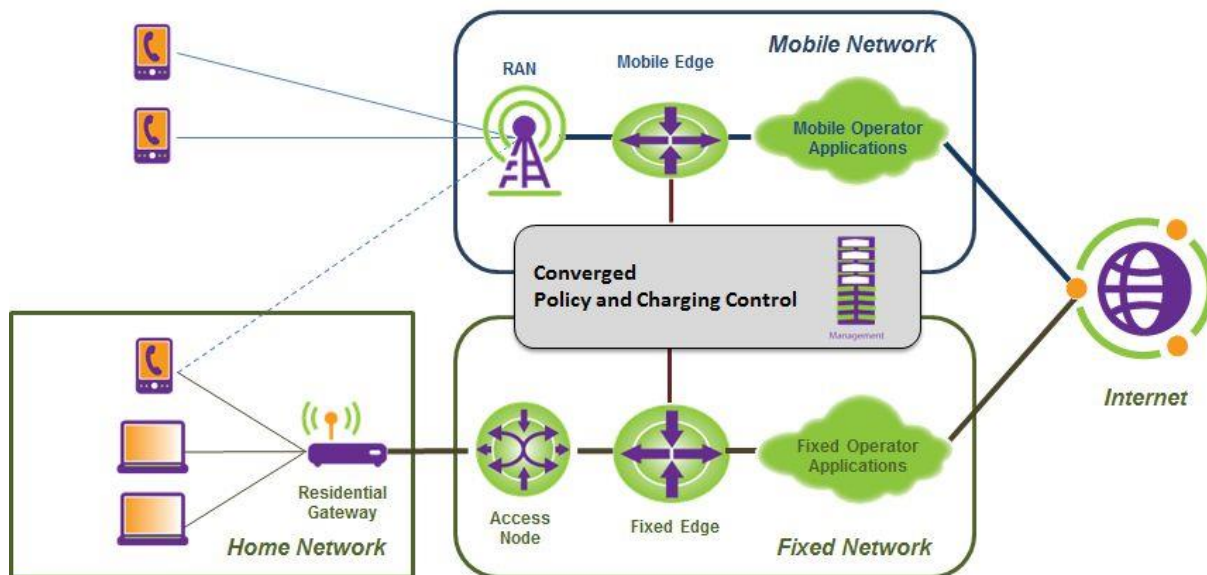

Figure 1 – Converged Policy and Charging Control for Shared Data Plan

4.2 Next hop change based on policies

In certain situations, the service provider has some service offerings that can range from video-on-demand to the access to a specific application in the network. In most cases the service can be identified by traffic parameters (IP address, protocol and port / port-range): the 5-tuple.

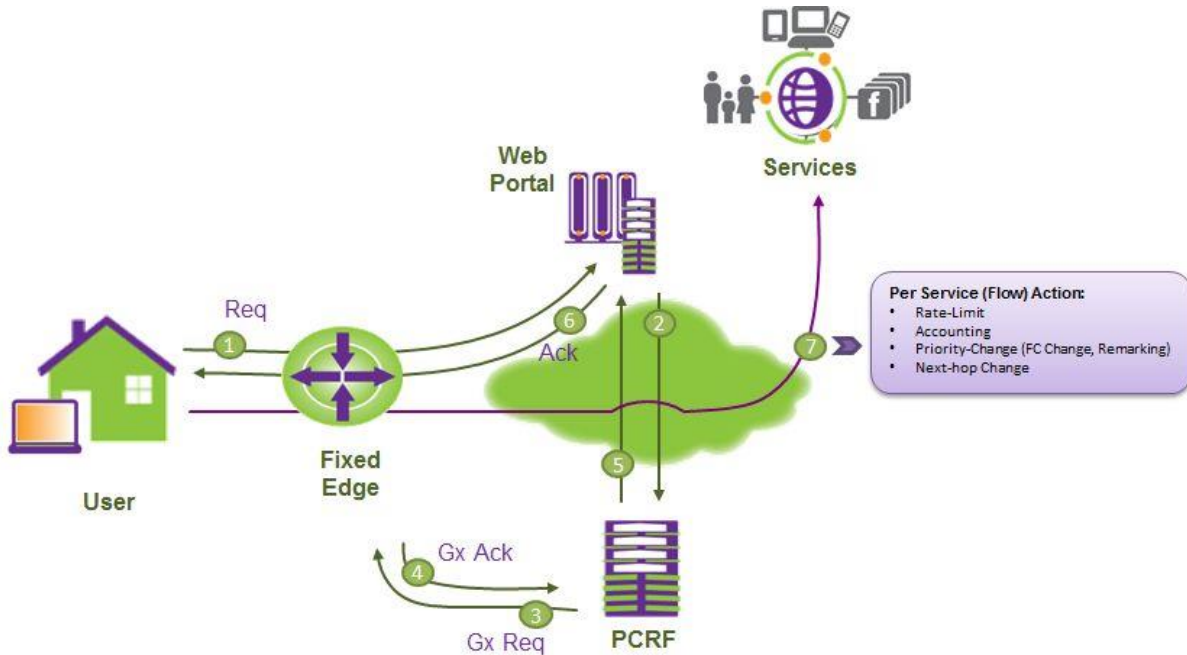

Figure 2 – Flow-based action based on the 5-tuple

Those service offerings can be accessed by a user, which is currently connected to the network, via a web portal (step 1 of Figure 2). Once the authentication/payment is performed, the service back-end submits the parameters defining the network delivery of the offered service to the PCRF (step 2 of Figure 2). At this point the PCRF converts those parameters into rules and submit them to the Fixed Edge via Gx. The Fixed Edge acknowledges then the rules activation (steps 3-6 of Figure 2), meaning the network is ready for the service traffic to be started from the subscriber side (step 7 of Figure 2).

The rules submitted by the PCRF allow the Fixed Edge to enforce several flow-based actions based on the service identified by the 5-tuple. Among those actions, TR-134c1 [3] considers setting the Rate Limits; configuring the Accounting settings; and setting up Traffic Priority by modifying the Forwarding Class.

In addition, service providers could also decide to change the Next-Hop based on rules activation. Next-Hop change could be achieved in two ways: by setting the next-hop interface, when the outbound interface is a point-to-point link – e.g. Asynchronous Transfer Mode (ATM) or MPLS); or by setting the next-hop IP address, when the service is delivered over broadcast medium like an Ethernet/VLAN network.

Note: Taking into account TR-300 Issue 1 is aligned with 3GPP Rel-12 for Policy Converge, the Next-Hop change can be only provided by means of pre-defined PCC Rules.

5 Reference Architecture

5.1 Reference Architecture Diagrams

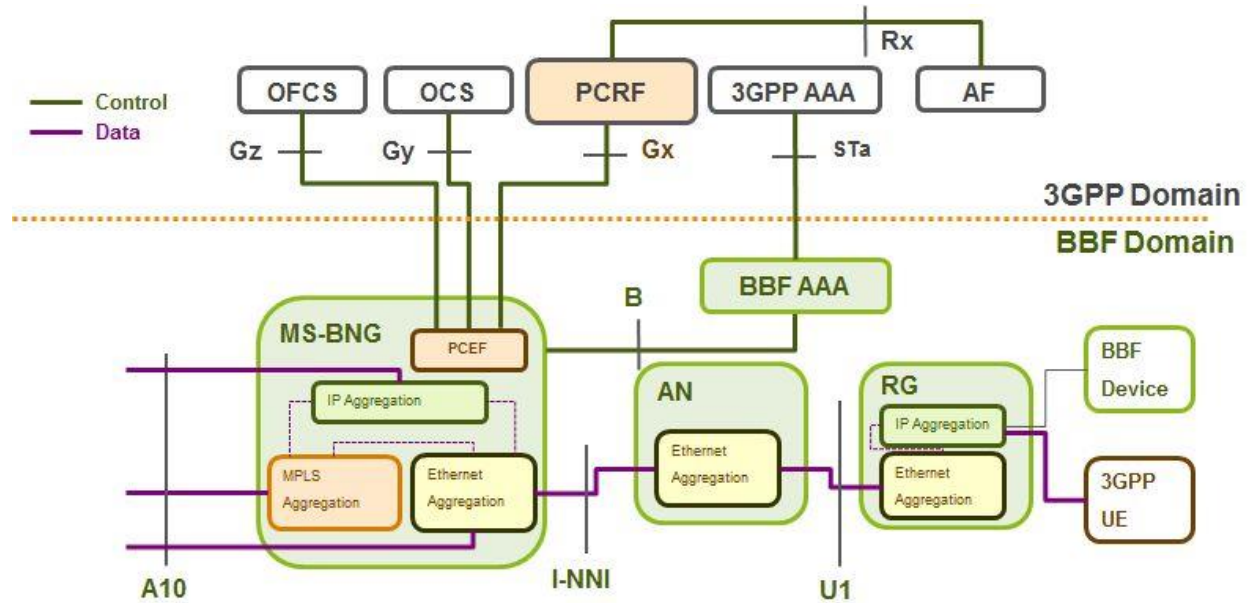

Figure 3 – Architecture for Gy/Gz based accounting architecture

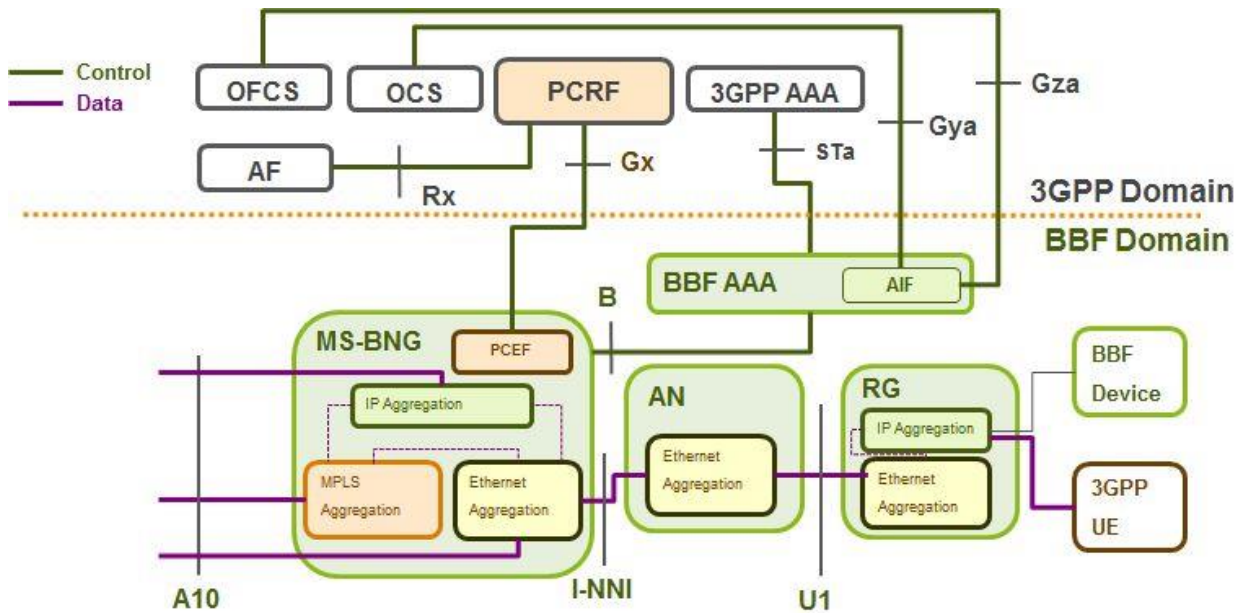

Figure 4 – Architecture for AAA-based accounting

5.2 Network Entities

This section describes the functionality of each network entity that comprises the converged policy management architecture in section 5.1.

5.2.1 PCRF

The PCRF is a functional entity making policy decisions for network control, gating, QoS and charging. Such policy decisions are based on subscriber preferences, and are applied on an IP Session, IP Flows and/or aggregate flows basis.

The PCRF functionality is defined in 3GPP TS 23.203 [13], which addresses the requirements in Technical Report to support convergence between Fixed Broadband and 3GPP networks.

5.2.2 PCEF

The PCEF is a logical entity that enforces policy decisions. The PCEF is responsible for traffic policy enforcement of unicast traffic.

Policy Enforcement may be applied at an IP Session, IP Flow and aggregate level.

In the context of this Technical Report, the PCEF as it is specified in Annex S/3GPP TS 23.203 [13] is located at the MS-BNG.

5.2.3 AF

The Application Function (AF) is a logical entity offering applications that require dynamic policy and charging control (*e.g.* that require a certain minimum bandwidth for the service to be delivered with an acceptable end-user experience). The AF interacts with the PCRF communicating the required service information.

The AF functionality is defined in 3GPP TS 23.203 [13].

5.2.4 OCS

The OCS is a logical entity in the mobile operator domain that provides online credit control per Subscriber IP Session or per flow, part of the Subscriber IP Session.

The OCS functionality is defined in 3GPP TS 32.240 [15] and specific requirements for Converged Policy Management are defined in Section 6.3.2.

5.2.5 OFCS

The OFSC is a logical entity in the mobile operator domain that provides offline credit control per Subscriber IP Session.

The OFCS functionality is defined in 3GPP TS 32.240 [15] and specific requirements for Converged Policy Management are defined in Section 6.3.2.

5.2.6 AIF

The AIF is a logical entity located in the Fixed Broadband AAA that interacts with the 3GPP OCS/OFCS providing AAA-based charging in a Converged Policy Management scenario.

The AIF requirements for Converged Policy Management are defined in Section 6.3.3.

5.3 Reference Points

Section 6/TR-134c1 [3] describes the Fixed Broadband Network Logical Functions that require information flows for processing policy decisions and enforcement

Figure 5 depicts such Fixed Broadband Network Elements and the applicable interfaces. Figure 5 is an adaption of Figure 27/TR-134c1 [3], due to, in the context of this Technical Report, the PDP element is implemented by the PCRF, and the PEP is implemented by the PCEF in the MS-BNG.

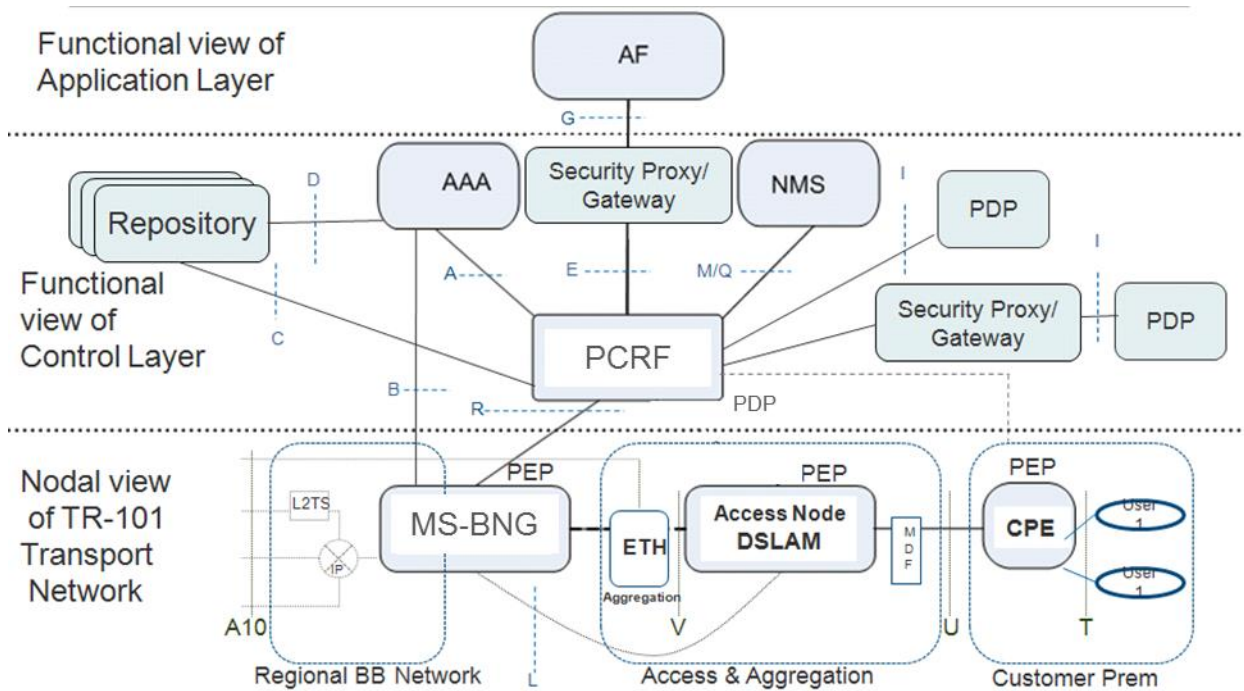

Figure 5 – Fixed Broadband Domain Elements and Interfaces

5.3.1 Rx Reference Point

The Rx reference point resides between the AF and the PCRF. The Rx is an implementation of the TR-134c1 [3] E/G reference point (Figure 5).

The Rx reference point is defined in 3GPP TS 23.203[13].

The AF may reside in the service provider network or in a 3rd party's network.

Note: The TR-134c1 [3] defines requirements for the PDP (in the context of this document, the PCRF) that enable secure and controlled access by Network Service Providers (NSPs) and Application Service Providers (ASPs) to the Policy Control infrastructure. In a converged network this requirement is covered by 3GPP TS 23.203 [13].

The Rx reference point transports application level session information from AF to PCRF that includes but it is not limited to:

- IP filter information to identify the flow for policy control and/or differentiated charging.
- Media/application bandwidth requirements for QoS control and media priority relative to other media in a multi-media session.
- Service Identifier.
- Priority of the connection that reflects the user's priority.
- Emergency service (e.g. 911 in the USA) indication.
- Government Emergency Telecommunication Service (ETS) per national regulatory requirements.
- Charging key to enable correlation of charging records by the charging system created by the AF and BBF access domains.

The Rx reference point enables the AF to subscribe to event notifications detected by the Fixed Broadband access network.

5.3.2 Gx Reference Point

The Gx reference point is specified per 3GPP 23.203 [13] and resides between the PCEF in the MS-BNG and the PCRF. The Gx is an implementation of the TR-134c1 [3] R reference point (Figure 5).

The Gx reference point enables the transfer of policy (e.g. QoS) and charging control decisions from the PCRF to the PCEF in:

- Fixed device scenario.
- 3GPP UE scenario.

The Gx interface supports both the PUSH and PULL model.

The Gx reference point is used to:

- Provision, modify and remove rules for Policy and charging control (i.e. PCC Rules) from the PCRF to the PCEF.
- Install events triggers at the PCEF and notify the PCRF when the PCEF detects an event.
- Communicate the AF Charging key in order to enable correlation of charging records by the charging system that are created by the AF and the BBF access domain.

5.3.3 Charging Reference Points

5.3.3.1 Gy/Gz Reference Point

The Gy reference point allows online credit control for flow based charging. The functionalities required across the Gy reference point are defined in TS 32.251 [16] and is based on RFC 4006 [20].

Note: The management of 3GPP TS 32.251 [16] Gy charging characteristic parameter and Gy Fixed Broadband Operator Identifier parameter are not required by TR-300 Issue 1.

The Gz reference point enables transport of flow based offline charging information. The Gz interface is specified in TS 32.240[15].

5.3.3.2 B Reference Point

According to Section 6/TR-134c1 [3], The B reference point supports authentication authorization and accounting. This section describes B usage only for AAA-based charging.

The requirements for accounting/charging are in TR-101i2 [1], TR-144 [4] and TR-146 [6]. Section 4.14/TR-134c1 [3] requires that the policy framework support pre-/post-paid and per-use charging capabilities.

This interface is used for:

- Accounting/charging for fixed devices.
- Accounting/charging for 3GPP UE BBF routed traffic.

5.3.4 STa Reference Point

The STa reference point connects the Fixed Broadband AAA Server to the 3GPP AAA Server. It is defined in 3GPP TS 23.402 [14], and it is used for Fixed Broadband and 3GPP wireless interworking per TR-203 [8] and TR-291 [10].

This reference point is not applicable for authentication of fixed device and fixed session, but is applicable for authentication of mobile devices attaching to the fixed network.

The STa reference point is used for:

- 3GPP UE Authentication.
- Charging for 3GPP UE BBF routed traffic.

6 Policy Control and Charging Requirements

6.1 General Requirements

According to TR-134c1 [3], there are three different ways of providing policies to a Fixed Broadband PEP:

- Policies configured locally in the PEP (i.e. PCEF in the MS-BNG in TR-300) ;
- Policies provided by the AAA via Remote Authentication Dial-In User Service (RADIUS);
- Policies provided by the PDP (i.e. PCRF in TR-300) via R (i.e. Gx in TR-300). These are the ones considered by PCC architecture.

The requirements below describe policy management according to PCC architecture. However, they don't exclude the option of making use of any of the other two alternatives.

- [R-1] The PCEF in the MS-BNG MUST be able to initiate, modify and terminate the IP-CAN Session through the Gx reference point.
- [R-2] The PCEF in the MS-BNG MUST be able to request policies from the PCRF over the Gx interface.
- [R-3] The PCEF in the MS-BNG MUST be able to receive policies from the PCRF over the Gx interface.
- [R-4] The PCRF MUST be able to send policies to the PCEF in the MS-BNG over the Gx interface.
- [R-5] The PCRF must be able to provision policy rules at PCEF in the MS-BNG based on a request from the PCEF (PULL mode), or based on a request from the AF, a timer expiration or a subscription profile modification via web portal (PUSH mode).
- [R-6] The PCEF in the MS-BNG MUST be able to apply policies to subscriber IP-CAN Sessions.
- [R-7] The PCEF in the MS-BNG MUST be able to enforce policy for unicast traffic.
- [R-8] The PCEF in the MS-BNG MUST support policy enforcement for both downstream and upstream traffic.
- [R-9] The PCEF in the MS-BNG MUST acknowledge the reception of policies from the PCRF.
- [R-10] The PCEF in the MS-BNG MUST be able to activate/deactivate pre-provisioned policies per list received from the PCRF over the Gx interface.

[R-11] The PCEF in the MS-BNG MUST be able to give precedence to the policies provided by the PCRF over the others.

[R-12] The PCEF in the MS-BNG MUST notify the PCRF if it fails to install policies received from PCRF. The PCEF in the MS-BNG MUST then apply the local policies or the policies provided by the AAA via RADIUS.

[R-13] In case the PCRF is not available at the time of subscriber/host instantiation, the PCEF in the MS-BNG MUST be able to provide the subscriber/host with default policies.

[R-14] The PCEF in the MS-BNG MUST be able to implement the Next-Hop policy based on predefined PCC Rules provided by the PCRF.

[R-15] The PCEF in the MS-BNG MUST be able to provide the Service Set Identifier (SSID) and/or Basic Service Set Identifier (BSSID) used by the UE or fixed WLAN device when initiating the IP-CAN Session establishment over Gx for the authorization by the PCRF.

Note: In the context of Fixed Broadband and 3GPP Mobile interworking, Section 7/TR-291 [10] includes requirements on how the SSID and/or BSSID information is obtained by the RG and provided to the network

[R-16] The PCRF MUST be able to terminate the NMS/OSS M/Q interface in order to create/modify/delete pre-provisioned rules.

Note: The M/Q interface specification is out scope of TR-300.

6.1.1 Session Mapping Requirements

Two operation modes are defined in BBF (TR-124i3 [2] and TR-146 [6]):

1. Network Address Translation (NAT) Case: A line-based service where the MS-BNG allocates the same IP address for all terminals behind a Residential Gateway (RG). In this case, the entity that is authenticated and managed is the RG, and the identity sent over the Gx interface to the PCRF is the line identifier or the Media Access Control (MAC) Address of the RG- Per TR-134c1 [3], the PCEF can provide the Circuit-ID and/or Remote-ID identified by DHCPv4 Option 82 (RFC3046 [18]) to the PCRF.

2. No NAT case: A Terminal / device based service where the MS-BNG manages an IP address per individual terminal. In this case, the entity that is authenticated and managed is the individual terminal (e.g. 3GPP UE or fixed device), and the identity over Gx is the Subscription-ID.

For a 3GPP UE, the Subscription-ID is the International Mobile Subscriber Identity (IMSI). For a BBF device, the Subscription-ID is defined in Section 6.1/TR-146 [6].

The diagram in Figure 6 depicts the logical binding of Subscriber IP Session and IP-CAN Session.

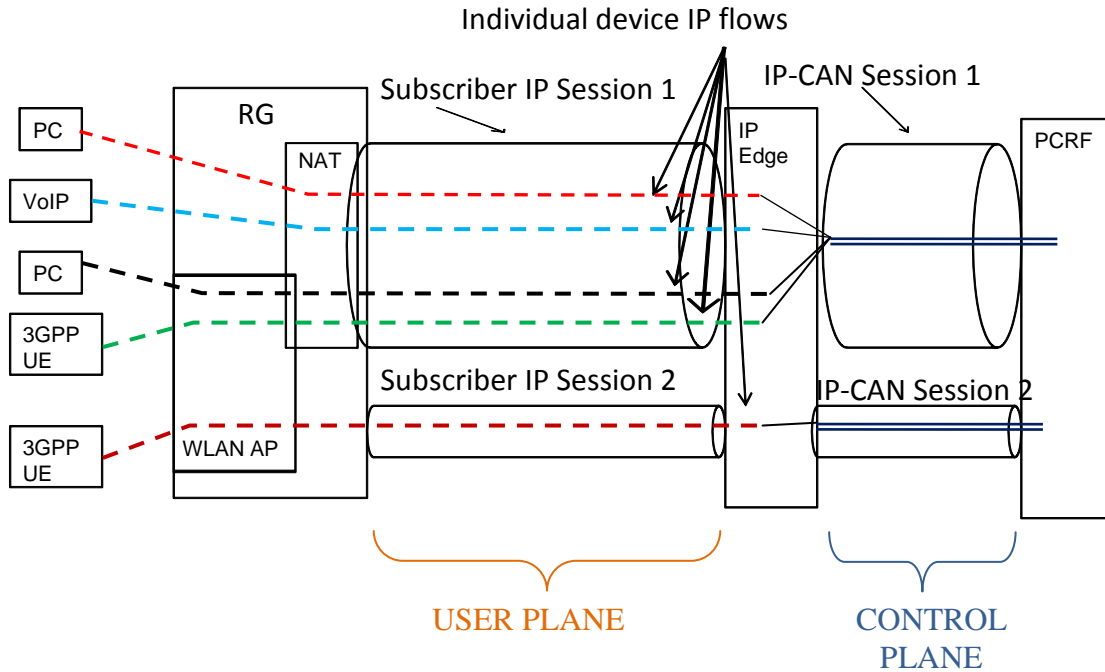

Figure 6 – Logical Binding of Subscriber IP Session and IP-CAN Session

In NAT case, the RG allocates local/private IPv4 addresses to devices, and there is one subscriber IP Session between RG and MS-BNG for all devices connected to the RG, as depicted in Figure 6.

In No-NAT case (based on RG configuration, all or some devices can bypass NAT), each device (i.e. 3GPP UE or fixed device) has one Subscriber IP Session.

[R-17] If the PCEF in the MS-BNG assigns an IP address for the 3GPP UE, the MS-BNG MUST initiate the IP-CAN Session establishment over Gx for the 3GPP UE.

[R-18] For the NAT case, The RG Subscriber IP Session establishment MUST trigger the PCEF-initiated IP-CAN Session establishment procedure with the PCRF.

[R-19] When the device traffic is bridged at the RG, the PCEF in the MS-BNG MUST be able to trigger the IP-CAN Session establishment procedure with the PCRF once the subscriber IP Session is established.

[R-20] When the device traffic is bridged at the RG, the PCEF in the MS-BNG MUST be able to bind a Subscriber IP Session to an IP-CAN Session.

[R-21] The PCEF in the MS-BNG MUST be able to include the Circuit-ID and/or Remote-ID provided by DHCPv4 Option 82 in IP-CAN Session establishment messages.

[R-22] At IP-CAN Session establishment, the PCRF MUST be able to receive from the PCEF in the MS-BNG the 3GPP UE local IP address, default QoS, APN and IMSI.

[R-23] At IP-CAN Session establishment, the PCEF in the MS-BNG MUST be able to send to the PCRF the 3GPP UE local IP address, default QoS, APN and IMSI.

6.1.2 Event Triggers and Credit Reauthorization Triggers

[R-24] The PCRF MUST be able to indicate to the PCEF in the MS-BNG the events it wants notification of. Such events are called Event Triggers.

[R-25] The OCS MUST be able to indicate to the PCEF in the MS-BNG the events it wants notification of. Such events are called Credit Reauthorization Triggers.

[R-26] The PCEF in the MS-BNG MUST support the Event Triggers defined in Table 1 and the Credit Reauthorization Triggers Table 2.

[R-27] When an event matching an Event Trigger in Table 1 occurs, the PCEF in the MS-BNG MUST report it to the PCRF.

[R-28] When an event matching a given Credit Reauthorization Trigger in Table 2 occurs, the PCEF in the MS-BNG MUST report it to OCS.

Event Trigger	Definition	Reported from	Reported to
QoS change	Request of new Policy information upon any QoS change (e.g. Access Node Control Protocol (ANCP) report from Access Node (AN) indicating change in local loop parameters and change in link status of multi-link bundle if Subscriber Session is found on the multi-link interfaces).	PCEF in the MS-BNG	PCRF
Out of credit	The subscriber has run out of the allocated credit.	PCEF in the MS-BNG	PCRF

Event Trigger	Definition	Reported from	Reported to
Usage report	The Subscriber IP Session or the Monitoring key specific resources consumed by a UE or fixed device either reached the threshold or needs to be reported for other reasons.	PCEF in the MS-BNG	PCRF
IP Session start/stop	Indication that an IPv4 or IPv6 address has been allocated to the IP host, or that the IP address has been released from the IP host.	PCEF in the MS-BNG	PCRF

Table 1 – Event triggers at Gx

Credit Reauthorization Trigger	Definition	Reported from	Reports to
Credit authorization lifetime expiry	The OCS has limited the validity of the credit to expire at a certain time. When the lifetime expires the PCEF shall ask to the OCS the new credit.	PCEF in the MS-BNG	OCS
Idle timeout	The IP Flow of Application identified has no traffic for a certain (configurable) amount of time. This event enables the OCS to take back the remaining credit and use it for other purposes.	PCEF in the MS-BNG	OCS
QoS Change	The QoS is changed, e.g. due to a new QoS rules, so the PCEF asks for new credit applicable for the new authorized QoS. This event enables per QoS online charging.	PCEF in the MS-BNG	OCS

Table 2 – Credit Reauthorization Triggers at Gy

6.2 Requirements for QoS Control

6.2.1 QoS Information Elements

Table 3 lists the QoS information contained in a PCC rule applicable to the convergent scenario on Gx reference point. The definition of information contained in PCC Rules in clause 6.3 of 3GPP TS 23.203 [13] shall apply to the convergent scenario.

[R-29] The PCEF in the MS-BNG MUST be able to support the QoS Information Elements in Table 3

Information name	Description	Category	PCRF permitted to modify for a dynamic PCC rule in the PCEF in the MS-BNG
Rule identifier	See table 6.3/3GPP TS 23.203 [13]	Mandatory	No
Precedence	See table 6.3/3GPP TS 23.203	Mandatory	Yes
Service data flow template	See table 6.3/3GPP TS 23.203	Mandatory	Yes
Gate status	See table 6.3/3GPP TS 23.203		Yes
QoS class identifier	See table 6.3/3GPP TS 23.203	Mandatory	Yes
UL-maximum bitrate	See table 6.3/3GPP TS 23.203	Conditional (NOTE 1)	Yes
DL-maximum bitrate	See table 6.3/3GPP TS 23.203	Conditional (NOTE 1)	Yes
UL-guaranteed bitrate	See table 6.3/3GPP TS 23.203		Yes
DL-guaranteed bitrate	See table 6.3/3GPP TS 23.203		Yes
NOTE 1: Mandatory when policy control on SDF level applies			

Table 3 – QoS Information Elements of PCC rule

Note: There could be other information (e.g. QoS remarking capability or Aggregate Downlink/Uplink Subscriber Bitrate) that could be added on a vendor specific basis.

Note: An example of a mapping between 3GPP QoS parameters and BBF QoS parameters is available in Appendix III/TR-203 [8].

6.2.2 Admission Control

Section 6.4/TR-134c1 [3] provides a description of the admission control function (ACF).

[R-30] The PCEF in the MS-BNG SHOULD perform admission control in Fixed Broadband access.

Note: How the PCEF in the MS-BNG becomes aware of resources status and utilization levels is outside the scope of TR-300.

Note: Whether the PCEF in the MS-BNG can delegate the admission control process to other BBF nodes (such as the AN) is FFS.

[R-31] The PCEF in the MS-BNG MUST accept or reject the QoS and charging policies received from the PCRF based on the outcome of the admission control process

[R-32] Subject to national regulatory requirements the PCEF in the MS-BNG MUST be able to pre-empt/initiate the pre-emption of a lower priority subscriber IP Session in order to free up resources for the admission of a higher priority connection such as emergency services (e.g. E911) and government emergency telecommunication services.

6.2.3 Information Elements of Default QoS

The default QoS is the QoS assigned to the broadband subscriber line at device attachment/Log-In time. The PCRF may override the default QoS it receives from the PCEF in the MS-BNG at device attach/log-in.

[R-33] The PCEF in the MS-BNG MUST be able to receive default QoS policies from AAA Server over the B interface.

[R-34] The PCEF in the MS-BNG MUST be able to send the default QoS information element to the PCRF.

[R-35] The PCRF MUST be able to change the default QoS rules received from the PCEF in the MS-BNG based on the subscriber's QoS profile and other information available at the PCRF.

The following requirements apply for Guaranteed Bit Rate (GBR) /real time services when the Fixed Broadband network experience resource limitation.

[R-36] The PCRF MUST, at the activation of the Priority Data Service, initiate the modification of the Gx IP-CAN Session and includes new values for the QoS Class Identifier (QCI) of the subscriber IP Session as appropriate for the Priority Data Service.

- [R-37] The PCRF MUST, at the deactivation of the Priority Data Service:
- Determine normal QCI values for the Subscriber IP Session.
 - Initiate the modification of the Gx IP-CAN Session and includes normal QCI values.
- [R-38] The PCEF in the MS-BNG MUST be able to modify the QCI of PCC Rules of the Subscriber IP Session installed before the activation of the Priority Data Service to the QCI received from the PCRF.
- [R-39] The PCEF in the MS-BNG MUST be able to modify the QCI of PCC Rules of the Subscriber IP Session installed at the activation of the Priority Data Service to the QCI received from the PCRF after the Priority Data Service is deactivated.

6.3 Requirements for Charging Control

- [R-40] The PCEF in the MS-BNG MUST be able to support 3GPP Gy/Gz based charging or AAA based charging based on configuration
- [R-41] The PCEF in the MS-BNG MUST be able to count separately the data volumes on both the uplink and downlink direction of the subscriber IP Session.
- [R-42] The PCEF in the MS-BNG MUST be able to identify data volumes, elapsed time and Credit Reauthorization Triggers, as the ones defined in Table 2, for individual flows part of the subscriber IP Session.
- [R-43] The PCEF in the MS-BNG MUST be able to identify data volumes, elapsed time and Credit Reauthorization Triggers (defined in Table 2) per individual flows part of the subscriber IP Session.

6.3.1 Charging Control Information Elements

Table 4 includes the charging Informational Elements (IEs) over Gx for both the 3GPP Gy/Gz and AAA based charging solution.

- [R-44] The PCEF in the MS-BNG MUST be able to support the charging information elements in Table 4.

Information name	Description	Category	PCRF permitted to modify for a dynamic PCC rule in the PCEF in the MS-BNG
Charging Key	See table 6.3/3GPP TS 23.203		Yes
Service identifier	See table 6.3/3GPP TS 23.203		Yes
Application Service Provider Identifier	See table 6.3/3GPP TS 23.203	Conditional	Yes
Charging method	See table 6.3/3GPP TS 23.203	Conditional	Yes
Gate status	See table 6.3/3GPP TS 23.203		Yes
Measurement method	See table 6.3/3GPP TS 23.203		Yes
Application Function Record Information	See table 6.3/3GPP TS 23.203		Yes
Service identifier level reporting	See table 6.3/3GPP TS 23.203		Yes

Table 4 – Charging rule information elements

6.3.2 Architecture based on 3GPP Gy/Gz Interfaces

Converged Charging architecture based on 3GPP Gy/Gz Diameter interfaces is represented in Figure 3. In this architecture, charging control relies on the 3GPP Gy/Gz reference points enabling convergent online/offline charging, as detailed in Section 5.3.3.1, for fixed and 3GPP UE devices.

Online/Offline accounting can be turned on or off for a policy rule at any given time during the IP-CAN Session lifetime, using the policy management interface (Gx).

A PCC rule can be instantiated via Gx and have a default action associated with it. For example, the accounting servers (OCS in Gy or offline Diameter accounting server in Gz) can be pre-provisioned in the fixed BB node and implicitly associated with the PCC rule when the rule is instantiated. However, the default action (i.e. accounting off) may render accounting/credit-control inactive.

Only when the directive to enable the accounting is received via the Gx interface, the data collection for the PCC rule may start and the accounting records or credit-control will be reported.

Similar logic applies in the opposite direction (default action may be to have accounting/credit-control enabled and then it can be explicitly disabled via Gx at any time).

In addition the rating-group for Gy credit control should be configurable via Gx.

The PCEF in the MS-BNG shall consider the following requirements in order to fully support this architecture:

[R-45] The PCEF in the MS-BNG MUST be able to perform credit control per rating group when online charging is used for the subscriber IP Session, i.e. when 3GPP Gy based architecture is used.

[R-46] The PCEF in the MS-BNG MUST be able to report the individual flow usage per rating group or per combination of the rating group and service id.

6.3.3 AAA based Charging

This architecture is depicted in Figure 4. In this option, charging control relies on the accounting achieved by the AAA server and the MS-BNG via the B interface. However, there could be cases (e.g. some prepaid services) where there is a need of interacting with an OCS or OFCS. For such purpose, an AIF is defined. The 3GPP reference point between AIF and OCS is called Gya, and it is defined in Annex S.8.4/3GPP TS 23.203 [13]. The 3GPP reference point between AIF and OFCS is called Gza, and it is defined in Annex S.8.4/3GPP TS 23.203[13].

When the RADIUS B interface is used for accounting, the AIF retrieves a quota from the OCS in the EPC domain. Then it aggregates the accumulated usage based on information received from the MS-BNG over accounting signalling until the quota is reached, so that a new quota can be requested by the AIF from the OCS.

For offline charging, the AIF generates charging records based on the accounting information received over B interface

[R-47] The AIF MUST be part of the Fixed Broadband AAA server.

[R-48] The AIF MUST support Diameter Credit-control client as per RFC 4006 [20].

The AIF does not impose any new requirement on the MS-BNG since as per [R-47] it is part of the Fixed Broadband AAA server.

6.4 Usage Monitoring

In order to support convergent dynamic policy management based on network usage, Usage Monitoring defines the ability to enforce dynamic policy decisions based on the total network usage in real-time. Usage monitoring can be done at different levels: at IP Session level, at IP flow level, or at group of IP flow(s) level.

Using this functionality, the PCRF shall set and send over Gx the applicable volume and time thresholds to the PCEF located in the MS-BNG. Those thresholds shall be valid for an individual IP Session, IP flow or a group of IP flow(s) part of the Subscriber IP Session.

Note: Usage monitoring for a group of IP sessions is not requested in TR-300.

Consequently, the PCEF located at the MS-BNG shall notify the PCRF when a threshold is reached and report the accumulated usage since the last report for Usage Monitoring.

Table 5 comprises the information that is required to enable the usage monitoring of resources for individual applications/services or groups of applications/services.

Information name	Description	Category	Scope
Monitoring key	The Monitoring Key is the reference to a resource threshold.	Mandatory	Subscriber IP Session
Volume threshold (NOTE 1)	Defines the overall traffic volume value in octets after which the PCEF shall report usage to the PCRF for this monitoring key.	Optional	Monitoring key
Monitoring time	It indicates the time at which the PCEF shall store the accumulated usage information.	Optional	Monitoring Key
Subsequent Volume threshold	Defines the overall user traffic volume value in octets measured after Monitoring time, after which the PCEF shall report the Usage threshold reached trigger to the PCRF.	Optional, Conditional (NOTE 2)	Monitoring Key
NOTE 1: This attribute is also used by the PCEF, e.g. during Subscriber IP Session termination, to inform the PCRF about the resources that have been consumed by the subscriber.			
NOTE 2: This attribute is applicable in presence of Monitoring Time only.			

Table 5 – Usage Monitoring Control related information

- [R-49] When the PCRF provides the Event Trigger for Usage Report (as defined in section 6.1.2), the PCEF in the MS-BNG MUST activate Usage Monitoring.
- [R-50] The PCEF in the MS-BNG MUST be capable to apply Usage Monitoring for individual IP sessions, individual flows or a group of flows.
- [R-51] The PCEF in the MS-BNG MUST be able to notify the PCRF when a threshold is reached and report the accumulated usage since the last report for Usage Monitoring.

6.5 PCRF Discovery

In a multiple PCRF deployment the discovery and selection of the PCRF follows the principles defined in 3GPP TS 23.203 [13], clause 7.6: the PCEF shall be able to select the same PCRF. One

of the key variables in selecting the PCRF via the Diameter Routing agent (DRA) is the subscription-ID.

As stated in section 6.1.1, the Subscription-ID is the IMSI for the 3GPP UE. For a BBF device, the Subscription-ID is defined in Section 6.1/TR-146 [6].

6.5.1 PCEF in the MS-BNG – PCRF Discovery

[R-52] The PCEF in the MS-BNG MUST be able to send to the DRA the Subscription-ID, fixed device/3GPP UE local IPv4/ address or IPv6 prefix.

Based on service provider policy, it may be desirable to select the same PCRF for the RG Gx IP-CAN Session and the 3GPP UE BBF routed Gx IP-CAN Session using the Access Line Identifier as the input IE to the DRA.

[R-53] The PCEF in the MS-BNG MUST be able to send to the DRA the NSWO-APN, in addition to the IEs in [R-52], for the 3GPP UE.

7 Procedures

Procedures for the IP-CAN Session Establishment/Termination/Modification between the PCEF, located in the MS-BNG, and the PCRF are defined in the Annex S/3GPP TS 23.203 [13].

In this section the BBF specific actions for each procedure are highlighted and the 3GPP TS 23.203 [13] is referenced as convenient.

Note: In Annex S/3GPP TS 23.203 [13], the MS-BNG is referred as IP Edge.

7.1 IP-CAN Session Establishment

The IP-CAN Session Establishment is initiated by the MS-BNG after when it detects the RG, when in Routed mode, or the Fixed device/3GPP UE, when in Bridged mode, has been assigned an IPv4 address and/or IPv6 Prefix. Procedures for IP-CAN Session Establishment between MS-BNG and PCRF are described in Annex S/3GPP TS 23.203 [13].

Note that the IP-CAN Sessions that are established upon IP address assignment by the PCEF are always established per individual host. This means:

- In case of a bridged RG, each host will establish its own IP Session, and then there will be a separated IP-CAN Session per each host.
- In case of routed RG, there will be a single IP-CAN Session handling all the devices behind the RG.

7.2 IP-CAN Session Termination

The IP-CAN Session Termination is initiated by the MS-BNG when it detects that the Subscriber IP Session of the RG, when in Routed mode, or of the Fixed device/3GPP UE, when in Bridged mode, has been terminated. Procedures for IP-CAN Session Termination between MS-BNG and PCRF are described in Annex S/3GPP TS 23.203 [13].

7.3 IP-CAN Session Modification

The IP-CAN Session Modification is initiated either by the PCRF or by the MS-BNG (when it detects an event matching an Event Trigger as described in Table 1). Procedures for IP-CAN Session Modification between MS-BNG and PCRF are described in Annex S/3GPP TS 23.203 [13].

Appendix I. Prefix sharing issue

When a host attaches to a routed Residential Gateway, RG uses DHCPv6 Prefix Delegation as Requesting Router (RR) to request a prefix, (e.g. size /60) for home network. The MS-BNG acts as the Delegating Router (DR) assigning the IPv6 prefix to the RG. Note that the host can be both 3GPP UE and Fixed device, e.g. computer, IPTV Set Top Box (STB), etc.

In TR-300 convergence scenario the MS-BNG that support PCEF function initiates an IP Connectivity Access Network (IP-CAN) Session with the Policy and Charging Rules Function (PCRF) to receive the Quality of Service (QoS) parameters. The MS-BNG provides IPv6 Prefix and User Equipment (UE) ID which in this case is equal to the home network line ID to the PCRF.

The MS-BNG binds the IP Subscriber Session for RG in the Fixed Broadband network with the IP-CAN Session identified by line ID and IPv6 Prefix provided to PCRF during IP-CAN Session establishment. The MS-BNG may apply admission control and performs enforcement of quality of service based on the parameters received from the PCRF.

In this scenario the 3GPP UE is authenticated using EAP-AKA authentication method where the AAA server is in 3GPP network while MS-BNG can act as authenticator or as AAA proxy as defined in TR-146 [6]. At the end of a successful authentication, the MS-BNG receives an accept message either when acts as authenticator or when AAA proxy, with the 3GPP UE host id, i.e. Network Access Identifier (NAI) in User-Name attribute Host id.

In case of stateless address auto configuration, the host sends a Router Solicitation message to RG and RG sends a Router Advertisement with an IPv6 prefix, the home network prefix. The host creates a 128-bit IPv6 address using this prefix and adding its interface id. Having completed the address configuration, the host can start communication with the Internet to use the Internet services.

Another host attaches to RG and also establishes an IPv6 address using the home network prefix. The MS-BNG is not involved in this process and all other such address assignments. In this case no authentication is performed. So the MS-BNG does not receive a host id either from 3GPP network or Fixed Broadband AAA server.

The above operation steps assumed that stateless address auto configuration (SLAAC) is used. DHCPv6 based stateful address assignment can also be used. In case of routed RG, RG can be DHCPv6 relay agent communicating with a DHCPv6 server in the service provider's IP network. DHCPv6 server in assigning IPv6 addresses to the hosts uses a method where /64 prefixes are never shared between hosts in different home networks.

The RG does not signal to the MS-BNG the IPv6 address assigned to a host, e.g. visiting host 1 or 2, so the MS-BNG acting as PCEF is not able to start any 3GPP IP-CAN Session for the given host ID, IPv6 Address corresponding to each single host, i.e. the Local_Host_1 and visiting host 1 or 2.

Each host in the home network creates an IPv6 address which is global and this address can be used to identify the host traffic and would enable PCEF to enforce the proper QoS after establishing an IP-CAN Session to download the required parameters. UE ID given to the mobile network is the home network line id which is the same for all the hosts in the home network.

There is no standardized solution that can be used to solve the host identification issue encountered in the prefix sharing context. Note that more globally, nearly every time policies must be applied on a per UE basis (e.g. UE traffic tunneled or NATed in RG), there's an issue regarding how to distinguish the UE from the RG. A more exhaustive list of use cases, several of which make sense in the context of the BBF E2E Architecture can be found at: <http://tools.ietf.org/html/draft-boucadair-intarea-host-identifier-scenarios-03>.

End of Broadband Forum Technical Report TR-300