

TR-249

Testing of G.993.2 Self-FEXT Cancellation (vectoring)

Issue: 1
Issue Date: March 2014

Notice

The Broadband Forum is a non-profit corporation organized to create guidelines for broadband network system development and deployment. This Broadband Forum Technical Report has been approved by members of the Forum. This Broadband Forum Technical Report is not binding on the Broadband Forum, any of its members, or any developer or service provider. This Broadband Forum Technical Report is subject to change, but only with approval of members of the Forum. This Technical Report is copyrighted by the Broadband Forum, and all rights are reserved. Portions of this Technical Report may be copyrighted by Broadband Forum members.

THIS SPECIFICATION IS BEING OFFERED WITHOUT ANY WARRANTY WHATSOEVER, AND IN PARTICULAR, ANY WARRANTY OF NONINFRINGEMENT IS EXPRESSLY DISCLAIMED. ANY USE OF THIS SPECIFICATION SHALL BE MADE ENTIRELY AT THE IMPLEMENTER'S OWN RISK, AND NEITHER the Forum, NOR ANY OF ITS MEMBERS OR SUBMITTERS, SHALL HAVE ANY LIABILITY WHATSOEVER TO ANY IMPLEMENTER OR THIRD PARTY FOR ANY DAMAGES OF ANY NATURE WHATSOEVER, DIRECTLY OR INDIRECTLY, ARISING FROM THE USE OF THIS SPECIFICATION.

Broadband Forum Technical Reports may be copied, downloaded, stored on a server or otherwise re-distributed in their entirety only, and may not be modified without the advance written permission of the Broadband Forum.

The text of this notice must be included in all copies of this Broadband Forum Technical Report.

Issue History

Issue Number	Approval Date	Publication Date	Issue Editor	Changes
1	3 March 2014	2 April 2014	Frank Van der Putten, Alcatel-Lucent	Original

Comments or questions about this Broadband Forum Technical Report should be directed to help@broadband-forum.org.

Editor	Frank Van der Alcatel-Lucent Putten	frank.van_der_putten@alcatel-lucent.com
Metallic Testing WG Chair	Les Brown	Huawei Technologies lesbrown@sympatico.ca
Vice Chair	Lincoln Lavoie	UNH InterOperability Lab lylavoie@iol.unh.edu
Vice Chair	Massimo Sorbara	Ikanos Communications msorbara@ikanos.com

Table of Contents

EXECUTIVE SUMMARY	8
1 PURPOSE AND SCOPE	9
1.1 PURPOSE	9
1.2 SCOPE	9
2 REFERENCES AND TERMINOLOGY	10
2.1 CONVENTIONS	10
2.2 REFERENCES	10
2.3 DEFINITIONS	11
2.4 ABBREVIATIONS	12
2.5 G.997.1 PARAMETERS	13
3 TECHNICAL REPORT IMPACT	14
3.1 ENERGY EFFICIENCY	14
3.2 IPV6.....	14
3.3 SECURITY.....	14
3.4 PRIVACY	14
4 COMMON TEST INFORMATION	15
4.1 COMPLIANCE REQUIREMENTS	15
5 EQUIPMENT FEATURES	16
5.1 SUT INFORMATION	16
5.2 TEMPERATURE AND HUMIDITY	18
5.3 TEST LOOPS	18
6 TEST ENVIRONMENTS	19
6.1 TEST CONFIGURATIONS	19
6.2 SYSTEM UNDER TEST SETTINGS	20
6.2.1 <i>Band Profiles</i>	20
6.2.2 <i>Line Settings</i>	21
6.2.3 <i>Profile Line Combinations</i>	26
6.2.4 <i>Test Plan Passing Criteria</i>	26
6.3 TEST SETUP.....	26
6.3.1 <i>Splitter Requirements</i>	26
6.3.2 <i>Loop Models</i>	26
6.3.3 <i>Noise Models</i>	27
6.3.4 <i>Noise injection</i>	27
6.3.5 <i>Crosstalk Accuracy</i>	28
7 TEST EQUIPMENT REQUIREMENTS.....	31
8 PERFORMANCE TESTING OF VECTORED SYSTEMS	32
8.1 COLLOCATED VECTORING CPES TEST CASE.....	32
8.1.1 <i>Purpose</i>	32

8.1.2	<i>Configuration</i>	32
8.1.3	<i>Method of procedure</i>	33
8.1.4	<i>Pass/Fail criteria</i>	35
8.2	COLLOCATED VECTORING AND LEGACY CPES TEST CASE (OPTIONAL).....	36
8.2.1	<i>Purpose</i>	37
8.2.2	<i>Configuration</i>	37
8.2.3	<i>Method of procedure</i>	37
8.2.4	<i>Pass/Fail criteria</i>	39
8.3	COLLOCATED VECTORING AND VECTORING-FRIENDLY CPES TEST CASE (OPTIONAL) 39	
8.3.1	<i>Purpose</i>	40
8.3.2	<i>Configuration</i>	40
8.3.3	<i>Method of procedure</i>	40
8.3.4	<i>Pass/Fail criteria</i>	41
8.4	NON-COLLOCATED VECTORING CPES TEST CASE (2 LOOP LENGTHS)	42
8.4.1	<i>Purpose</i>	42
8.4.2	<i>Configuration</i>	42
8.4.3	<i>Method of procedure</i>	43
8.4.4	<i>Pass/Fail criteria</i>	43
8.5	NON-COLLOCATED VECTORING CPE TEST CASE (3 LOOP LENGTHS)	43
8.5.1	<i>Purpose</i>	44
8.5.2	<i>Configuration</i>	44
8.5.3	<i>Method of procedure</i>	44
8.5.4	<i>Pass/Fail criteria</i>	45
8.6	RFI NOISE TEST CASE	45
8.7	LONG TERM STABILITY TEST CASE	45
8.7.1	<i>Purpose</i>	45
8.7.2	<i>Configuration</i>	45
8.7.3	<i>Method of procedure</i>	46
8.7.4	<i>Pass/Fail criteria</i>	46
9	FUNCTIONAL TESTING OF VECTORED SYSTEMS.....	48
9.1	VECTORING SUPPORT FOR DIFFERENT PROFILES TEST CASE.....	48
9.1.1	<i>Purpose</i>	48
9.1.2	<i>Configuration</i>	48
9.1.3	<i>Method of procedure</i>	48
9.1.4	<i>Pass/Fail criteria</i>	49
9.2	ACTIVATION AND DISORDERLY SHUTDOWN OF LINES IN A VECTORED GROUP	50
9.2.1	<i>Purpose</i>	50
9.2.2	<i>Configuration</i>	50
9.2.3	<i>Method of procedure</i>	50
9.2.4	<i>Pass/Fail criteria</i>	51
9.3	MICRO-INTERRUPTION TEST CASE	51
9.3.1	<i>Purpose</i>	52
9.3.2	<i>Configuration</i>	52
9.3.3	<i>Method of procedure</i>	53
9.3.4	<i>Pass/Fail criteria</i>	54

- 9.4 SINGLE WIRE-INTERRUPTION TEST CASE 54
 - 9.4.1 Purpose 55
 - 9.4.2 Configuration..... 55
 - 9.4.3 Method of procedure..... 55
 - 9.4.4 Pass/Fail criteria 56
- 10 TESTING REPORTING OF PARAMETERS DEFINED IN G.997.1 57**
 - 10.1 VECTORING MODE ENABLE (VECTORMODE_ENABLE) TEST CASE (OPTIONAL) 57
 - 10.1.1 Purpose 57
 - 10.1.2 Configuration..... 57
 - 10.1.3 Method of procedure..... 58
 - 10.1.4 Pass/Fail criteria 58
- I APPENDIX I NOISE INJECTION..... 59**

List of Figures

Figure 1 – Generic test setup.	19
Figure 2 – Generic test setup for the multiple cable segment case.	20
Figure 3 - Direct channel $H(i,i)$ and crosstalk channel $H(i,j)$	28
Figure 4 – Illustration of crosstalk accuracy requirements.	30
Figure 5 - Test setup for collocated vectoring CPEs.	32
Figure 6 - Test setup for collocated vectoring and legacy CPEs.	36
Figure 7 - Test setup for collocated vectoring and vectoring-friendly CPEs.	40
Figure 8 - Test setup for non-collocated vectoring CPEs (2 loop lengths).	42
Figure 9 - Test setup for non-collocated vectoring CPEs (3 loop lengths).	44
Figure 10 - Test setup for the micro-interruption test.	52
Figure 11 - Model of a single wire-interruption.	55

List of Tables

Table 1 - DSLAM Information	16
Table 2 - CPE Information.....	17
Table 3 - CO Splitter Information.....	17
Table 4 - CPE Splitter Information.....	17
Table 5 - Configuration Settings.....	17
Table 6 - Temperature and Humidity Range of Test Facility.....	18
Table 7 - Loops used for Testing	18
Table 8 - Common Band Profiles	21
Table 9 - List of Common Line Settings	22
Table 10 - DPBO Settings for G.993.2 Annex B Testing.....	23
Table 11 - UPBO Settings.....	24
Table 12 - General Line Settings for RTX.....	24
Table 13 - General Line Settings for I-FEC.....	25
Table 14 - Specific Line Settings for RTX	25
Table 15 - Specific line settings for I-FEC	25
Table 16 - Concatenated Common Settings, Testing Combination Description	26
Table 17 - Loops used for Testing	27
Table 18 – Frequencies for measurement of Far-End Coupling.....	29
Table 19 - PLMAX Values for $8 \leq N \leq 48$	36
Table 20 - Common Combined Band Profiles.....	48
Table 21 - VECTORMODE_ENABLE parameter settings	57
Table 22 - Pass/Fail criteria for the VECTORMODE_ENABLE test.....	58

Executive Summary

This Broadband Forum Technical Report, TR-249, as part of the Broadband Suite, provides a set of performance and functional requirements and test methods for vectoring capable VDSL2 systems (a combination of a DSLAM and CPE) implemented in accordance with G.993.5 [4] (Self-FEXT cancellation (vectoring) for use with VDSL2 transceivers) and for basic VDSL2 functionalities implemented in accordance with G.993.2 [2] (Very high speed digital subscriber line transceivers 2 (VDSL2)). Its key value is in the verification of the vectoring specific performance and functionality in order to facilitate consistent and successful vectored VDSL2 services by network operators. The focus of this Technical Report is not on requirements for introduction of a new equipment in a given deployment and it does not replace operators' pre-deployment testing. Specific operator deployment and service requirements, as well as specific regulatory requirements may require additional tests to those described in this test plan.

1 Purpose and Scope

1.1 Purpose

TR-249 provides a set of performance and functional requirements for vectoring capable VDSL2 implementations according to ITU-T Recommendation G.993.5 [4]. The focus of TR-249 is testing the vectoring functionality within a combination of a particular DSLAM type (i.e., the VCE and the VTU-O) and a particular CPE type (i.e., the VTU-Rs). Broadband Forum performance Test Plans for non-vectorized DSL typically contain absolute performance requirements on a single line. The nature of the vectoring functionality and a pragmatic approach for the test setup have led for this Technical Report to formulate performance objectives for vectoring operation via a statistical approach and relative to the performances of the so called FEXT-free and Full-FEXT operation. The content includes conventional equipment configurations, test setups and methods, and the requirements which have been identified by the Broadband Forum as being relevant for service operators' deployment.

1.2 Scope

This Technical Report is intended to provide an interoperability/performance/functionality test plan for ITU-T Recommendation G.993.5 [4] "Self-FEXT cancellation (vectoring) for use with VDSL2 transceivers". Deployment scenarios in the scope of this Technical Report include deployments from the Central Office (CO) and Fiber-To-The-x (FTTx) remote deployments.

The scope of this Technical Report also covers validation of the functionality of the Control, Inventory, and Reported parameters defined in ITU-T Recommendation G.997.1 [6] for the related G.993.5 functionality (see section 10).

2 References and Terminology

2.1 Conventions

In this Technical Report, several words are used to signify the requirements of the specification. These words are always capitalized. More information can be found in RFC 2119 [1].

SHALL	This word, or the term “REQUIRED”, means that the definition is an absolute requirement of the specification.
SHALL NOT	This phrase means that the definition is an absolute prohibition of the specification.
SHOULD	This word, or the adjective “RECOMMENDED”, means that there may exist valid reasons in particular circumstances to ignore this item, but the full implications must be understood and carefully weighed before choosing a different course.
SHOULD NOT	This phrase, or the phrase "NOT RECOMMENDED" means that there may exist valid reasons in particular circumstances when the particular behavior is acceptable or even useful, but the full implications should be understood and the case carefully weighed before implementing any behavior described with this label.
MAY	This word, or the adjective “OPTIONAL”, means that this item is one of an allowed set of alternatives. An implementation that does not include this option MUST be prepared to inter-operate with another implementation that does include the option.

2.2 References

The following references are of relevance to this Technical Report. At the time of publication, the editions indicated were valid. All references are subject to revision; users of this Technical Report are therefore encouraged to investigate the possibility of applying the most recent edition of the references listed below.

A list of currently valid Broadband Forum Technical Reports is published at www.broadband-forum.org.

Document	Title	Source	Year
[1] RFC 2119	<i>Key words for use in RFCs to Indicate Requirement Levels</i>	IETF	1997
[2] G.992.5	<i>Asymmetric digital subscriber line transceivers 2 (ADSL2) – Extended bandwidth (ADSL2plus)</i>	ITU-T Recommendation	2009

[3]	G.993.2	<i>Very high speed digital subscriber line transceivers 2 (VDSL2)</i>	ITU-T Recommendation	2011
[4]	G.993.5	<i>Self-FEXT cancellation (vectoring) for use with VDSL2 transceivers</i>	ITU-T Recommendation	2010
[5]	G.996.1	<i>Testing of DSL transceivers</i>	ITU-T Recommendation	2001
[6]	G.997.1	<i>Physical layer management for digital subscriber line transceivers</i>	ITU-T Recommendation	2012
[7]	G.998.4	<i>Improved impulse noise protection for DSL transceivers</i>	ITU-T Recommendation	2010
[8]	TR-114	<i>VDSL2 Performance Test Plan (Issue 2)</i>	Broadband Forum Technical Report	2012
[9]	TR-115	<i>VDSL2 Functionality Test Plan (Issue 2)</i>	Broadband Forum Technical Report	2012
[10]	TR-138	<i>Accuracy Tests for Test Parameters</i>	Broadband Forum Technical Report	2009
[11]	ATIS-0600024	<i>Multiple-Input Multiple-Output Crosstalk Channel Model</i>	ATIS Technical Report	2009

2.3 Definitions

The following terminology is used throughout this Technical Report. See section 2.3 of TR-114 [8].

Crosstalk	Interfering signal received in one copper pair of a cable from services in other copper pairs of the same cable.
Far-End Crosstalk	Crosstalk between DSL services at the far end of the copper loop away from the DSL transmitter.
Full FEXT measurement	NDR/SNRps/SNRM measurement for all vectored lines with the FEXT cancellation disabled in upstream and downstream for all lines. Referred to as FULL FEXT performance (e.g., FEXT_NDR).
vectoring-friendly CPE	A VDSL2 CPE that supports G.993.2 Annex X (“G.993.5-friendly G.993.2 operation in the downstream direction”) or G.993.2 Annex Y (“Full G.993.5-friendly G.993.2 operation”). See G.993.2 [3].
Legacy CPE	A VDSL2 CPE that is neither downstream vectoring-friendly (G.993.2 Annex X), nor full vectoring-friendly (G.993.2 Annex Y), nor vectoring (G.993.5) capable.

Lock a line	Deactivate a line by configuring the line in the administrative state “locked”. The VTU-O transitions to the O-IDLE state (ignore VTU-R). The line transitions to the L3 state. See ITU-T G.993.2 Figures 12-1 and 12-2.
nextpowerof2	Function defined as $\text{nextpowerof2}(n) = 2^{\text{ceil}(\log_2(n))}$.
Self-FEXT	FEXT created by lines carrying DSL signals of the same type. In vectoring context, FEXT generated by neighboring VDSL2 lines, either vectored or not. There are two types of self-FEXT: in-domain and out-of-domain.
Showtime	The state of a DSL connection when application payload data can be transmitted over the connection.
Single line measurement	NDR/SNRps/SNRM measurement for each vectored line with the FEXT cancellation disabled in upstream and downstream for all lines. Referred to as NO XTALK performance (e.g., SINGLE_NDR).
System Under Test	A combination of N CPEs connected to a vectoring capable DSLAM.
Unlock a line	Activate a line by configuring the line in the administrative state “unlocked”. The VTU-O transitions to the O-SILENT state (monitor VTU-R), and continues through initialization to the O-SHOWTIME state. The line transitions to the L0 state. See ITU-T G.993.2 Figures 12-1 and 12-2.
Vectored Group	The set of lines over which transmission from the AN is eligible to be coordinated by pre-compensation (downstream vectoring), or over which reception at the AN is eligible to be coordinated by post-compensation (upstream vectoring), or both. Depending on the configuration of the vectored group, downstream vectoring, upstream vectoring, both or none may be enabled (see ITU-T Rec. G.993.5 clause 3 - definitions).
Vectored measurement	NDR/SNRps/SNRM or performance monitoring counters (PM) measurement for all vectored lines with the FEXT cancellation enabled in upstream and downstream for all lines. Referred to as VECTORED performance (e.g., VECTORED_NDR).
Vectoring Control Entity	The function in a vectored System that manages vectoring for the lines in a DSLAM.

2.4 Abbreviations

This Technical Report uses the following abbreviations:
See section 2.4 of TR-114 [8].

AWGN	Additive White Gaussian Noise
CDF	Cumulative Distribution Function
CO	Central Office
CPE	Customer Premises Equipment
DPBO	Downstream Power Back Off

DS	DownStream
DSL	Digital Subscriber Line
FEC	Forward Error Correction
FEXT	Far-End CrossTalk
FTTx	Fiber to the x (x is e.g., N for Node or C for Cabinet)
I-FEC	Interleaved Forward Error Correction
INP	Impulse Noise Protection
IL	Insertion Loss
LDMF	Loop diagnostic mode forced
MDF	Main Distribution Frame
NEXT	Near-End CrossTalk
NTP	Network Termination Point
PM	Performance Monitoring
PMSF	Power management state forced
PMMode	Power management state enabling
RA	Rate Adaptive
RFI	Radio Frequency Ingress
RTX	Retransmission
SNR	Signal-to-Noise Ratio
SNRM	Signal-to-Noise Ratio Margin
SUT	System Under Test
UPBO	Upstream Power Back Off
US	UpStream
VCE	Vectoring Control Entity
VTU-O	VDSL2 Transceiver Unit at the Optical Network Unit
VTU-R	VDSL2 Transceiver Unit at the Remote site

2.5 G.997.1 Parameters

See Section 2.5/TR-115 [9].

Parameter	Section in G.997.1
FEXT_CANCEL_ENABLEDs	7.3.1.13.6
FEXT_CANCEL_ENABLEUs	7.3.1.13.5
Full initialization count	7.2.1.3.1
VECTORMODE_ENABLE	7.3.1.13.9

3 Technical Report Impact

3.1 Energy Efficiency

TR-249 has no impact on Energy Efficiency.

3.2 IPv6

TR-249 has no impact on IPv6.

3.3 Security

TR-249 has no impact on Security.

3.4 Privacy

Any issues regarding privacy are not affected by TR-249.

4 Common Test Information

4.1 Compliance requirements

For the purpose of this Test Plan TR-249, the System under Test (SUT) is the combination of a particular DSLAM type and a particular CPE type, both supporting operation according to G.993.5 [4], with the DSLAM connected to N CPEs of this particular CPE type, and consisting of a vectored group of at least N lines. All vectoring capable CPEs used during the testing SHOULD be from the same manufacturer and model, running the same software/firmware version. It is expected that the DSLAM/CPE combination has passed the TR-114 [8] and TR-115 [7] Test Plans, for the appropriate G.993.2 Annex and Band Profile to be tested according to this Test Plan. The number of CPE tested SHALL be at least 8.

For a SUT to pass this Test Plan TR-249, the SUT SHALL pass the set of performance and functional test cases defined in this Test Plan as applicable to the selected band-profile. The selected band-profile SHALL be included as part of the test report, along with other configuration settings (see sections 5).

TR-249 accompanies TR-114 [8] “*VDSL2 Performance Test Plan*” and TR-115 [9] “*VDSL2 Functionality Test Plan*” and TR-138 [10] “*Accuracy Tests for Test Parameters*”. TR-114 defines the tests for verification of performance requirements (physical layer and system level) defined in G.993.2 [3]. TR-115 defines the tests for verification of functional requirements (physical layer and system level) defined in G.993.2 [3]. TR-138 defines the tests for verification of the accuracy of the reported test (Physical Layer OAM configuration and performance monitoring) parameters defined in G.993.2 [3] and G.997.1 [6].

5 Equipment Features

Test results obtained as a result of testing performed in accordance with TR-249 SHALL contain the information described in sections 5.1, 5.2, and 5.3.

5.1 SUT Information

Table 1 through Table 4 are intended to provide test engineers and readers of the test report with sufficient information about the SUT in order to ensure repeatability of results and to allow for accurate comparisons of reported test results. The tables SHALL be populated prior to the start of the testing and SHALL be included as part of the test report. All fields SHALL be populated; if an item is not applicable to the SUT, the item MAY be marked as “Not Applicable”.

Table 1 - DSLAM Information

DSLAM Manufacturer	
DSLAM Product Name/Model	
DSLAM system software release number	
Line Card Name/Model	
Line Card part number	
Line Card serial number	
Line Card software/firmware release number	
System Vendor ID	
VCE Vendor ID	
VCE version	
Transceiver chipset manufacturer	
Transceiver chipset HW version	
Transceiver chipset FW version	
VDSL2 Band-Profiles supported	
Total number of ports	
Maximum number of CPEs the DSLAM is capable of supporting in one vectored group	

Table 2 - CPE Information

CPE Manufacturer	
CPE Product Name/Model	
CPE software release number	
CPE serial number	
System Vendor ID	
Transceiver chipset Manufacturer	
Transceiver chipset HW version	
Transceiver chipset FW version	
VDSL2 Band-Profiles supported	

Splitters SHOULD NOT be used for the testing. However, if used, Table 3 and Table 4 SHALL be populated prior to the start of the testing and SHALL be included as part of the test report.

Table 3 - CO Splitter Information

Manufacturer	
Product Name/Model	
Version number	
Serial number	
Type (ISDN 2B1Q, ISDN 4B3T, etc.)	

Table 4 - CPE Splitter Information

CPE Splitter Manufacturer	
Product Name/Model	
Version number	
Serial number	
Type (ISDN 2B1Q, ISDN 4B3T, etc.)	

Table 5 is intended for test engineers to provide readers of the test report with sufficient information about the configuration of the SUT in order to ensure repeatability of results and to allow for accurate comparisons of reported test results. The table SHALL be populated prior to the start of the testing and SHALL be included as part of the test report. All fields SHALL be populated; if an item is not applicable to the SUT, the item MAY be marked as “Not Applicable”.

Table 5 - Configuration Settings

Common Band Profile	
Number of CPEs connected (N)	

5.2 Temperature and Humidity

The ranges of temperature and humidity of the test facility, over the entire time tests are conducted, SHALL be recorded in a manner similar to that shown in Table 6 and SHALL be included as part of the test report. The acceptable range of temperatures SHOULD be between 15 °C (59 °F) and 35 °C (95 °F). The humidity SHOULD be between 5% and 85%.

Table 6 - Temperature and Humidity Range of Test Facility

Parameter	High	Low
Temperature		
Humidity		

5.3 Test Loops

The test loops SHALL be recorded in a manner similar to that shown in Table 7 and SHALL be included as part of the test report. For the loop attenuation at 1 MHz, see section 6.3.2.

Table 7 - Loops used for Testing

Loop	Minimum Attenuation at 1 MHz	Maximum Attenuation at 1 MHz	Cable type, wire gauge and length Cable or Crosstalk Emulator manufacturer and model number
Short loop			
Medium loop			
Long loop			

A cable or multi-pair crosstalk emulator description SHALL be included as part of the test report. For a cable, this description SHALL indicate the total number of pairs, the number and size of binders and how each binder is structured. For a multi-pair crosstalk emulator, this description SHALL indicate the total number of pairs and any other information relevant to describe it.

6 Test Environments

This section contains all the specifications and information required for building the basic testing environment (e.g., test configurations, setup of the simulated network environment, main settings of the system under test) for VDSL2 vectoring test cases defined in this test plan. Test case specific configurations and settings are defined in their related section.

6.1 Test Configurations

The generic test setup is shown in Figure 1 (for the case of collocated CPEs).

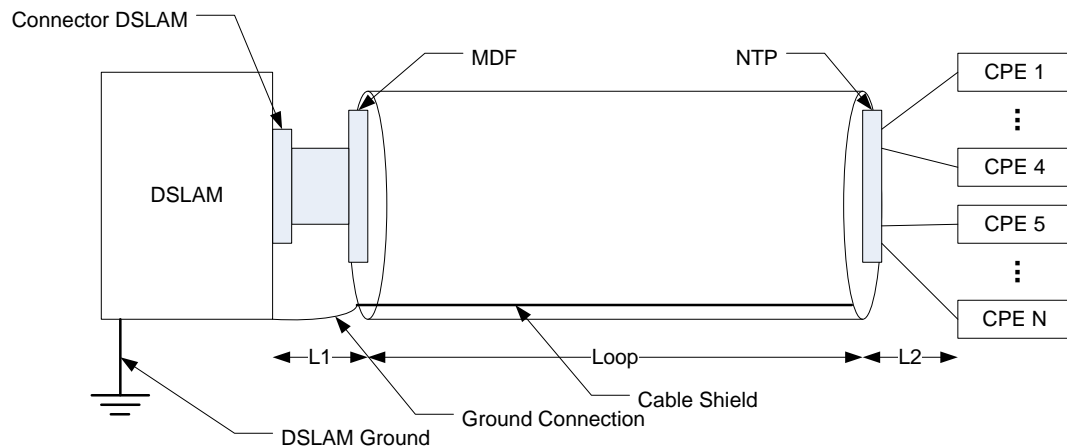

Figure 1 – Generic test setup.

The following sections are identified in the generic test setup in Figure 1:

- **Connector DSLAM:** adaption between copper pairs of system cable and the linecard(s). There may be some level of crosstalk introduced within the connector wiring.
- **DSLAM-side cable section (L1):** interconnects the DSLAM/Linecard and the copper pair cable and SHOULD be as short as possible. For all test setups, the interconnection (consisting of one or more multi-pair cables introducing crosstalk) SHALL be no longer than 10 meters and SHALL be CAT3 or better. There is some level of crosstalk introduced within this cable section.
- **Main Distribution Frame (MDF):** a distribution frame connecting the copper pair cable to the DSLAM-side cable section.
- **Loop:** typical access network cable or multi-pair crosstalk emulator as defined in section 6.3.2. The crosstalk introduced within this cable section is considered the dominant one. The crosstalk between the N copper pairs within this cable section (i.e., excluding the L1 and L2 cable sections) SHALL comply with the accuracy requirements defined in section 6.3.5.
- **Network termination Point (NTP):** a small distribution frame connecting the copper pair cable to the CPE-side cable section.

- **CPE-side cable section (L2):** interconnects the CPEs and the copper pair cable and SHOULD be as short as possible. For all test setups, the interconnection (consisting of one or more multi-pair cables introducing crosstalk) SHALL be no longer than 10 meters and SHALL be CAT3 or better. There is some level of crosstalk introduced within this cable section.

If shielded cable is used for testing, then the cable shield of the first/closest cable connected to the DSLAM SHALL be connected to the DSLAM frame ground at the same point where the cable connects to the “MDF” or “Connector DSLAM.” The CPE side of the cable shield SHALL NOT be connected to ground. If multiple cable segments are used, the cable shield of each segment SHALL be connected to the only to the cable shield of the previous cable segment. Figure 1 and Figure 2 show the correct ground connects for the single and multiple cable segment cases respectively.

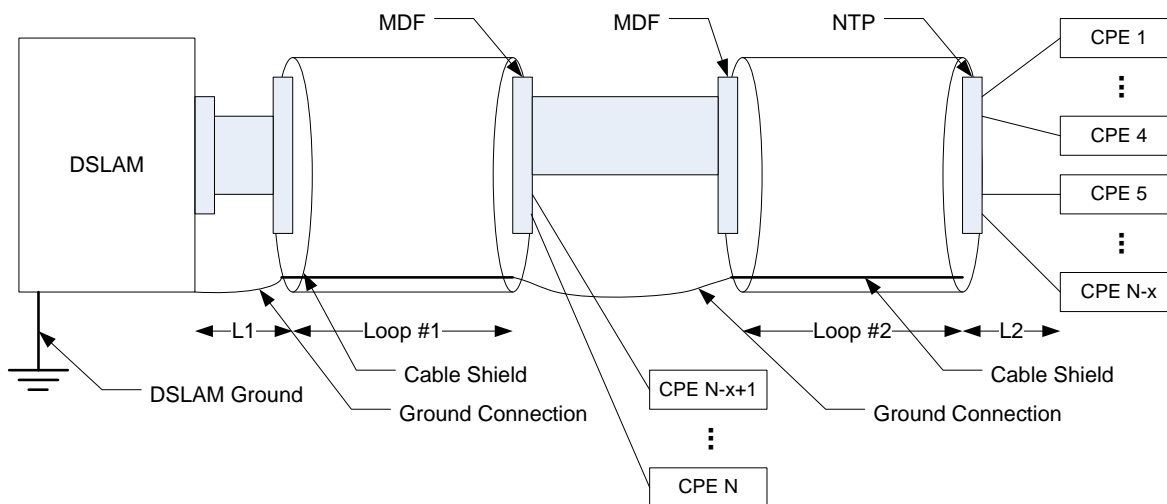

Figure 2 – Generic test setup for the multiple cable segment case.

If a binder based cable is used to perform the tests, pairs SHOULD be chosen in a way to progressively fill the binders. The loop device (cable or emulator), cable type (if applicable), the chosen pairs and their association to the DSLAM ports SHALL not change while performing the Test Cases. The lengths chosen for the short, medium and long loops SHALL not change while performing the Test Cases.

6.2 System Under Test Settings

6.2.1 Band Profiles

Band Profiles are used to describe the VDSL2 profile under test. The structure of the abbreviation used throughout the document for Band Profiles is as follows.

The abbreviation begins with a letter designating the G.993.2 Annex to which the profile refers. The next letter refers to the US0 type of the profile, hence indicating profiles for:

- AA: G.993.2 Annex A with US0 corresponding to Annex A of G.992.5 (VDSL2 over POTS).
 - BA: G.993.2 Annex B with US0 corresponding to Annex A of G.992.5 (VDSL2 over POTS).
- NOTE - The same abbreviation is used for profile 17a where US0 is not available.
- BB: G.993.2 Annex B with US0 corresponding to Annex B of G.992.5 (VDSL2 over ISDN).

The next symbols are the numeric and letter description of the profile itself. Common band profiles are provided in Table 8.

Table 8 - Common Band Profiles

VDSL2 Band-profile	Annex A		Annex B				
	AA12a	AA17a	BA12a	BB12a	BA17a	BB17a	BA17ADE
Profile	12a	17a	12a	12a	17a	17a	17a
Annex	A	A	B	B	B	B	B
Limit PSD Mask (short name)	Table A.1/G.993.2	Table A.1/G.993.2	998-M2x-A (B8-4)	998-M2x-B (B8-6)	998E17-M2x-NUS0 (B8-18)	998ADE17-M2x-B (B8-12)	998ADE17-M2x-A (B8-11)
US0 type	EU32 (see Table A.2/G.993.2)	EU32 (see Table A.2/G.993.2)	A	B	A	B	A
MAXNOMATPds	+14.5 dBm	+14.5 dBm	+14.5 dBm	+14.5 dBm	+14.5 dBm	+14.5 dBm	+14.5 dBm

6.2.2 Line Settings

6.2.2.1 Common Line Settings

This section defines the modem settings of parameters that are common to the configurations of the SUT in this test plan. Common line settings are provided in Table 9.

Table 9 - List of Common Line Settings

Parameter	Setting	Description
All parameters but those specified below	Default value	
Power management state forced (PMSF)	0	
Power management state enabling (PMode)	0	
Loop diagnostic mode forced (LDMF)	0	
Automode cold start forced	0	
DPBO (G.993.2 Annex A)	Off	
DPBO (G.993.2 Annex B)	On, with settings defined in Table 10.	DPBO SHALL be enabled for all tests to protect legacy ADSL2plus deployed from CO locations.
UPBO	On, with settings defined in Table 11.	UPBO SHALL be enabled for all tests.
RFI notches	Off	
MAXSNRMds	Special Value or 31 dB	Reduction of transmit power is not required.
MAXSNRMus	Special Value or 31 dB	Reduction of transmit power is not required.
TARSNRMds	6 dB	
TARSNRMus	6 dB	
MINSNRMds	0 dB	
MINSNRMus	0 dB	
MSGMINds	16 kbit/s	
MSGMINus	16 kbit/s	
Preemption option flag, ds	00 ₁₆	
Preemption option flag, us	00 ₁₆	
Short packet option flag, ds	00 ₁₆	
Short packet option flag, us	00 ₁₆	
FORCEINP	1	
Downstream Downshift Noise Margin (RA-DSNRMds)	5 dB	

Downstream Minimum Downshift Rate Adaptation Interval (RA-DTIMEds)	2 sec	
Downstream Upshift Noise Margin (RA-USNRMds)	7 dB	
Downstream Minimum Upshift Rate Adaptation Interval (RA-UTIMEds)	8 sec	
Upstream Downshift Noise Margin (RA-DSNRMus)	5dB	
Upstream Minimum Downshift Rate Adaptation Interval (RA-DTIMEus)	2 sec	
Upstream Upshift Noise Margin (RA-USNRMus)	7 dB	
Upstream Minimum Upshift Rate Adaptation Upstream (RA-UTIMEus)	8 sec	
RTX_MODE	1	RTX_PREFERRED
VECTORMODE_ENABLE bits (3,2,1,0)	(1,1,1,1)	all modes enabled

NOTE - Due to the relative character of tests pass/fail criteria based on net data rates (NDRs), it is desired that measurements be done with lines initialized at an actual signal to noise margin (SNRM) close to the target margin (TARSNRM). Upshift (RA-USSNRM) and downshift (RA-DSSNRM) rate adaption thresholds are therefore intentionally set to respectively TARSNRM-1 and TARSNRM+1 in order to prevent the possibility that the NDR settles to an SNRM that's excessively far from the TARSNRM, which would be possible if SRA would not be active or if it would be configured with a wider threshold range.

Table 10 - DPBO Settings for G.993.2 Annex B Testing

Band-profile	DPBO EPSD	DPBO ESEL (dB at 1 MHz)	DPBO ESCM A	DPBO ESCM B	DPBO ESCMC	DPBO MUS (dBm/Hz)	DPBO FMIN (kHz)	DPBO FMAX (kHz)
BA12a, BA17a, BA17ADE	G.992.5 Annex A	27	0.1924	0.5960	0.2086	-95	138	2208
BB12a, BB17a	G.992.5 Annex B	27	0.1924	0.5960	0.2086	-95	254	2208

NOTE - The values of DPBOESCMA, B and C are referred to a PE04 loop model. Values that are configured according to G.997.1 SHALL be rounded to the nearest scalar value.

Table 11 - UPBO Settings

Band-profile	US0: (a, b)	US1: (a, b)	US2: (a, b)	US3: (a, b)
AA12a, AA17a	N/A	(53, 16.2)	(54, 10.2)	N/A
BA17a	N/A	(47.30, 21.14)	(54, 16.29)	(54, 16.29)
BA12a, BB12a, BB17a, BA17ADE	(40, 0)	(47.30, 21.14)	(54, 16.29)	N/A

NOTE - These DPBO and UPBO settings are based on legacy VDSL2 testing practices (see TR-114 [8]). They do not represent a recommendation for settings to be used in particular networks. These parameter sets have not been optimised for vectored operation. Parameter sets so optimised are for further study.

The tests SHALL be performed with retransmission (RTX) per G.998.4 in both upstream and downstream (RTX_MODE=1 [RTX_PREFERRED], see clause 7.3.1.11 of G.997.1 [6]) according to the RTX line settings. If retransmission is not supported in a particular direction, then testing in that direction SHALL be performed with interleaved Reed-Solomon coding (I-FEC) per G.993.2 [3] according to the I-FEC line settings.

Vectoring (G.993.5 [4]) SHALL be enabled during Single line, Full FEXT and Vectored measurements (see Table 9 and the VECTORMODE_ENABLE in clause 7.3.1.13.9 of G.997.1 [6]), while FEXT cancellation SHALL be set as follows:

- For the Vectored measurement, FEXT cancellation SHALL be enabled in upstream and downstream for all N lines (see FEXT_CANCEL_ENABLE_{Us} and FEXT_CANCEL_ENABLE_{Eds} in clauses 7.3.1.13.5 and 7.3.1.13.6 of G.997.1 [6] respectively);
- For the Single line measurement and Full FEXT measurement, FEXT cancellation SHALL be disabled in upstream and downstream for all N lines.

6.2.2.2 General Line Settings

This section defines the profile, latency and INP settings of the SUT. Deviations from these modem settings are indicated in the description of each test or test section. General line settings for downstream and upstream RTX are provided in Table 12. General line settings for downstream and upstream I-FEC are provided in Table 13.

Table 12 - General Line Settings for RTX

General line setting	Parameter	Setting	Description
R-17/2/41	INPMIN_REIN_RTX	2	DMT symbol protection against REIN
	INPMIN_SHINE_RTX	41	DMT symbols protection against SHINE
	SHINERATIO_RTX	2	Worst case PEIN retransmission overhead (percent %).

	LEFTR_THRESH	0.78	Low rate defect threshold
	DELAYMAX_RTX	17	ms
	DELAYMIN_RTX	0	Outlet shaper off

Table 13 - General Line Settings for I-FEC

General line-setting	Parameter	Setting	Description
I-8/2	delay_max _n	8	ms
	INP_min _n	2	symbols

6.2.2.3 Specific Line Settings

Nomenclature adopted for the specific line settings is as follows (see Table 14 and Table 15):

- The first two letters describe that the SUT operates in rate adaptive (RA) mode.
- The next letter and associated digits describe the profile latency and INP settings according to Table 12 (RTX) or Table 13 (I-FEC).
- The following two numbers are the upper limits of the downstream and upstream rates rounded and expressed in Mbit/s.

Table 14 - Specific Line Settings for RTX

RTX Specific line setting	DS RTX General line settings	US RTX General line settings	RA-Mode	DS Expected throughput (kbit/s)	US Expected throughput/Net data rate (kbit/s)
RA_R17/2/41_150_150 (for systems not supporting upstream RTX)	R-17/2/41	I-8/2	DYNAMIC	MAXETR_RTX = 150000 MAXNDR_RTX = 150000 MINETR_RTX = 518	MAXNDR = 150000 MINNDR = 160
RA_R17/2/41_150_150 (for systems supporting upstream RTX)	R-17/2/41	R-17/2/41	DYNAMIC	MAXETR_RTX = 150000 MAXNDR_RTX = 150000 MINETR_RTX = 518	MAXETR_RTX = 150000 MAXNDR_RTX = 150000 MINETR_RTX = 518

Table 15 - Specific line settings for I-FEC

Specific line-setting	General line-setting	RA-Mode	DS net data rate (kbit/s) (max- min)	US net data rate (kbit/s) (max-min)
RA_I_150_150	I-8/2	DYNAMIC	150000-128	150000-64

6.2.3 Profile Line Combinations

Common band-profiles as described in section 6.2.1 above are combined with line settings described in section 6.2.2 to specify the common settings for a system under test. Without enumerating each combination a new nomenclature is formed using the concatenation of the two common setting nomenclatures. Table 16 provides a few examples of these combinations without a complete listing of all of the expected combinations.

Table 16 - Concatenated Common Settings, Testing Combination Description

Band-profile	Specific line-setting	Profile-line combination
BB17a	RA_I_150_150	BB17a_RA_I_150_150
AA17a	RA_I_150_150	AA17a_RA_I_150_150
BA12a	RA_R17/2/41_150_150	BA12a_RA_R17/2/41_150_150
etc.	etc.	etc.

6.2.4 Test Plan Passing Criteria

To pass this Test Plan for one of the VDSL2 band-profiles defined in Table 8, it is required that the SUT(as defined in section 4.1) pass the set of performance and functional test cases applicable to that band-profile.

The VDSL2 band-profile selected for testing SHALL be chosen from among the common band profiles defined in Table 8 and SHALL be included as part of the test report. The loops selected for testing SHALL be chosen from among the loops defined in Table 17 and SHALL be included as part of the test report.

6.3 Test Setup

6.3.1 Splitter Requirements

Splitters SHOULD NOT be used for the testing.

6.3.2 Loop Models

The loops used for testing are shown in Table 17. The loops MAY be implemented through a multi-pair loop simulator or through a multi-pair cable.

Table 17 - Loops used for Testing

Loop type	Attenuation at 1 MHz	Examples (see NOTE 1)
Short loop	4.5 to 8.75 dB	200 to 350 m PE0.4mm 600 to 1100 feet 26awg 800 to 1400 feet of 24awg 250 to 450 m TP100
Medium loop	6.75 to 17.5 dB At least 2.25 dB higher than for short loop (see NOTE 2)	300 to 700 m PE0.4mm 900 to 2200 feet 26awg 1100 to 2800 feet of 24awg 400 to 950 m TP100
Long loop	13.5 to 21.85 dB At least 3.375 dB higher than for medium loop (see NOTE 3)	550 to 850 m PE0.4mm 1800 to 2800 feet 26awg 2200 to 3500 feet of 24awg 750 to 1200 m TP100
NOTE 1 - According to the theoretical cable model, and with loop lengths rounded to the nearest 50 meters or 100 feet multiple that meets the attenuation requirement.		
NOTE 2 – Examples: 100 m PE0.4mm, 333 feet 26awg, 400 feet of 24awg, and 133 m TP100.		
NOTE 3 – Examples: 150 m PE0.4mm, 500 feet 26awg, 600 feet of 24awg, and 200 m TP100.		

The accuracy of a loop is defined through the accuracy of each of its sections. Each section SHALL be a straight homogeneous loop with an attenuation at 1 MHz within the boundaries as specified in Table 17.

The N short/medium/long loops SHALL have an attenuation at 1 MHz within a spread (i.e., maximum minus minimum value) of 1/3/4 dB respectively. For each loop type, the minimum and maximum attenuation at 1 MHz SHALL be included as part of the test report (see section 5.3).

6.3.3 Noise Models

6.3.3.1 Stationary Noise

Stationary noise SHALL NOT be externally injected onto the loop during any tests defined in this test plan. External injection of stationary noise for testing for vectoring systems is for further study.

6.3.3.2 RFI Noise

For further study.

6.3.3.3 Impulse Noise

For further study.

6.3.4 Noise injection

Noise injection requirements are for further study. The Appendix I describes a possible method of noise injection with some performance considerations and impedance requirements for the injector circuitry.

6.3.5 Crosstalk Accuracy

This section defines the accuracy requirements for the crosstalk between the N pairs used in the test setup. For a test setup to be used for pass/fail testing on the SUT, the loop (excluding the L1 and L2 cable sections, see Figure 1) SHALL meet the crosstalk accuracy requirements defined in this section.

The Far-End Coupling is defined as the Far-End Crosstalk (FEXT) minus the Insertion Loss (IL). The Far-End Coupling measurement of cable or emulator used during the tests SHALL be included as part of the test report. The test report SHALL include what DSLAM/CPE port is connected to what copper pair in the cable/binder structure or in the crosstalk emulator and SHALL include the Far-End Coupling from any given copper pair into any other copper pair.

The Far-End Coupling between pair i and pair j SHALL be reported as the X_{dB} value, with X_{dB} defined as the amplitude offset of the crosstalk transfer function in dB, relative to the amplitude of the 99% worst case ATIS model (see ATIS-0600024 [11]) based on the measured direct channel.

$$X_{dB}(i, j) = 20\log_{10}(abs(H(i, j)) - WC99(i, i)),$$

where $WC99(i, i) = 20\log_{10}(abs(H(i, i)) \cdot f \cdot \sqrt{loopLength[m]} \cdot \kappa),$

and $\kappa = 1.594E-10, f$ is the frequency in Hz,

and $H(i, i)$ and $H(i, j)$ are defined as shown in Figure 1.

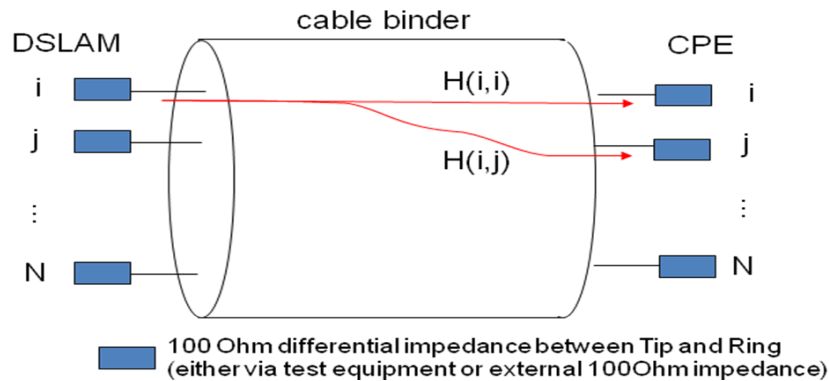

Figure 3 - Direct channel $H(i, i)$ and crosstalk channel $H(i, j)$.

Measurements SHALL be performed with 100 Ohm differential impedance between Tip and Ring on each of the N pairs in the test setup (either via test equipment or external 100 Ohm impedance).

The far-End Coupling SHALL be estimated from the X_{dB} values measured at the frequencies defined in Table 18 as follows: $X_{dB} = 10\log_{10}\left(average\left(10^{\frac{measured X_{dB}}{10}}\right)\right)$

Table 18 – Frequencies for measurement of Far-End Coupling.

Loop	Measurement frequencies
Short loop	1, 3, and 5 MHz
Medium loop	1, 3, and 5 MHz
Long loop	1, 3, and 5 MHz

The accuracy requirements for the crosstalk coupling are defined in terms of the Cumulative Distribution Function (CDF) of the $N \times (N - 1)$ X_{dB} values. The following values SHALL be determined from the measured X_{dB} values:

- P20: the 20% percentile,
- P50: the 50% percentile (median X_{dB} value),
- P80: the 80% percentile,
- P100: the 100% percentile (maximum X_{dB} value).

The following accuracy requirements SHALL apply to each binder in the cable (with percentiles over number of used pairs in the binder) or to the whole cable if the cable is not binder based (with percentiles over number (N) of used pairs in the cable):

- $P50_MIN \leq P50 \leq P50_MAX$,
- $P100 \leq P100_MAX$,
- $P50 + P20_MINDELTA \leq P20 \leq P50 + P20_MAXDELTA$,
- $P50 + P80_MINDELTA \leq P80 \leq P50 + P80_MAXDELTA$.

with:

- $P50_MIN = -20$ dB,
- $P50_MAX = -5$ dB,
- $P100_MAX = +10$ dB,
- $P20_MINDELTA = -9$ dB,
- $P20_MAXDELTA = -3$ dB,
- $P80_MINDELTA = +3$ dB,
- $P80_MAXDELTA = +9$ dB.

These accuracy requirements related to the $CDF(X_{dB})$ for a crosstalk coupling according to the ATIS model are illustrated in Figure 2.

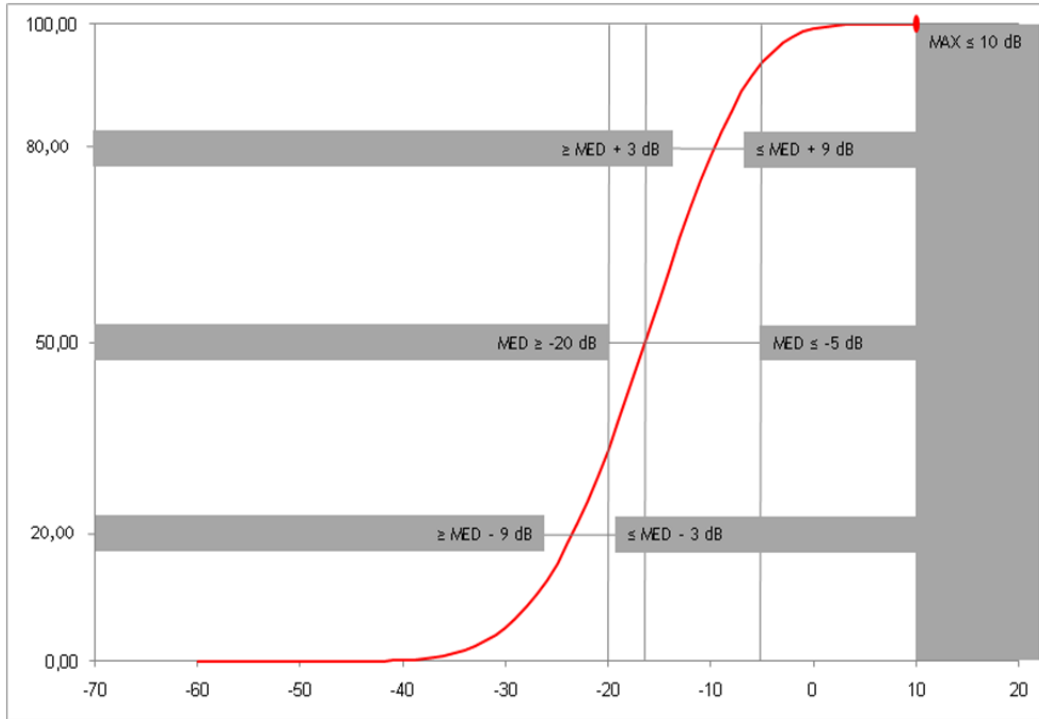

Figure 4 – Illustration of crosstalk accuracy requirements.

NOTE 1 - The accuracy requirements defined in this section apply to both cable emulators and real cables. When testing with real cables, the crosstalk distribution accuracy requirements may not necessarily be met. If testing is performed on such cables with lower or higher crosstalk, the specified pass/fail criteria of %loss and %gain may not be met.

NOTE 2 - The crosstalk accuracy is verified for each loop type independently (with N equal length loops). The test setup as verified above is applicable for both collocated and non-collocated testing topologies.

7 Test Equipment Requirements

The following test equipment SHALL be used for performance and functional testing (see the configurations defined in sections 8, 9, and 10):

- Multi-pair crosstalk emulator or a multi-pair cable;
- Micro-interruption generator;
- Single wire interruption generator.

When included in the test setup the micro-interruption generator and the single-wire interruption generator SHALL not degrade the frequency response of the attenuation of the cable (or emulator) by more than 0.1 dB from 20 kHz to 30 MHz.

8 Performance Testing of Vectored Systems

This section defines test cases for testing VDSL2 systems supporting the self-FEXT cancellation defined in the G.993.5 [4], referred to as vectoring.

Each test is performed with N being the number of CPEs in the SUT (see section 4.1), connected to the DSLAM over N lines, numbered 1 to N, with N at least 8. This MAY be equal to, or a subset of, the number of ports on the DSLAM. Both the value of N and the total number of ports on the SUT are declared before the test (see Table 1). Lines that are not under test SHALL be unlocked and SHALL have no CPE connected (L3 state).

NOTE - The testing time increases proportional with N, so for large N the testing time may become high.

8.1 Collocated Vectoring CPEs Test Case

The test setup for testing collocated vectoring CPEs is illustrated in Figure 5.

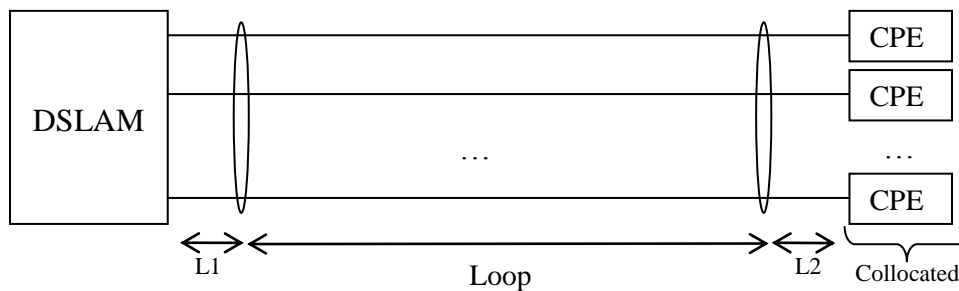

Figure 5 - Test setup for collocated vectoring CPEs.

8.1.1 Purpose

This test case verifies the vectoring capabilities of the SUT in the case where all CPEs support vectoring and are collocated. It compares the VECTORED performance (VECTORED_NDR) with the NO XTALK performance (SINGLE_NDR) and the FULL FEXT performance (FEXT_NDR).

8.1.2 Configuration

The test configuration is described in the following bullets:

- Conditions: The DSLAM and all CPEs SHALL support vectoring per G.993.5 [4]. At initialization, all VTU-O and all VTU-R transceivers SHALL go through the x-P-VECTOR signals.
- Number of lines with a CPE connected: N (numbered 1 to N). Line #1 to line #N have a G.993.5 CPE connected.
- Profile: One common band profile (defined in Table 8) SHALL be tested. The same profile line combination (defined in Table 16) SHALL be used on all N lines.

- Three loops (short loop and medium loop and long loop as defined in Table 17) SHALL be tested. For each test, all CPEs SHALL be at the same loop length from the DSLAM. The pass/fail criteria SHALL be met for each tested loop separately.

8.1.3 Method of procedure

Single line NDR/SNRps/SNRM measurement for each line:

1. Lock all N lines;
2. Disable upstream and downstream FEXT cancellation on all N lines;
3. Unlock line #1 and wait 181 seconds for line #1 to reach Showtime;
4. Wait 1 minute;
5. To ensure that the DSLAM port has not initialized over a crosstalk path, check that the CPE connected to DSLAM port #1, is in Showtime. If the CPE connected to DSLAM port #1 is not in Showtime, lock line#1 and go back to step 3.
6. Record the upstream actual net data rate and downstream actual net data rate (NDR) for line #1 (referred to as SINGLE_NDRus_1 and SINGLE_NDRds_1);
7. Record the upstream SNR per subcarrier and downstream SNR per subcarrier (SNRps) for line #1 (referred to SINGLE_SNRpsus_1 and SINGLE_SNRpsds_1);
8. Record the upstream SNR margin and downstream SNR margin (SNRM) for line #1 (referred to as SINGLE_SNRMus_1 and SINGLE_SNRMds_1);
9. Lock line #1;
10. Repeat steps 3 to 9 for each line #2 to line #N.

Full FEXT NDR/SNRps/SNRM measurement for each line:

1. Lock all N lines;
2. Disable upstream and downstream FEXT cancellation on all N lines;
3. Unlock all N lines as quickly as possible per the DSLAM implementation and wait $180 + \text{nextpowerof2}(N)$ seconds after the last line executes the unlock command for all N lines to reach Showtime (see NOTE);
4. Wait $480 + \text{nextpowerof2}(N)$ seconds for SRA to take effect;
5. Record the actual upstream net data rate and actual downstream net data rate (NDR) for all N lines (referred to as FEXT_NDRus_i and FEXT_NDRds_i, with i = linenummer 1 to N);
6. Record the upstream SNR per subcarrier and downstream SNR per subcarrier (SNRps) for all subcarriers on all N lines (referred to as FEXT_SNRpsus_i and FEXT_SNRpsds_i, with i = linenummer 1 to N);
7. Record the upstream SNR margin and downstream SNR margin (SNRM) for all N lines (referred to as FEXT_SNRMus_i and FEXT_SNRMds_i, with i = linenummer 1 to N);

NOTE - For example:

- For 48 lines, $N=48$ and $180+\text{nextpowerof2}(48) = 180+64 = 244$ seconds;
- For 192 lines, $N=192$ and $180+\text{nextpowerof2}(192) = 180+256 = 436$ seconds.

Vectored NDR/SNRps/SNRM measurement for each line:

1. Lock all N lines;
2. Enable upstream and downstream FEXT cancellation on all N lines;
3. Unlock all N lines as quickly as possible per the DSLAM implementation and wait $180+\text{nextpowerof2}(N)$ seconds after the last line executes the unlock command for all N lines to reach Showtime;
4. Wait $480+\text{nextpowerof2}(N)$ seconds for SRA to take effect;
5. Record the actual upstream net data rate and actual downstream net data rate (NDR) for all N lines (referred to as VECTORED_NDRus_i and VECTORED_NDRds_i, with i = linenumbers 1 to N);
6. Record the upstream SNR per subcarrier and downstream SNR per subcarrier (SNRps) for all subcarriers on all N lines (referred to as VECTORED_SNRpsus_i and VECTORED_SNRpsds_i, with i = linenumbers 1 to N);
7. Record the upstream SNR margin and downstream SNR margin (SNRM) for all N lines (referred to as VECTORED_SNRMus_i and VECTORED_SNRMds_i, with i = linenumbers 1 to N);
8. Record the upstream FEXT coupling and downstream FEXT coupling (XLINps) for all N lines (referred to as XLINpsds(i,j), with i = victim linenumbers 1 to N and for j = disturber linenumbers 1 to N with $j \neq i$).

For all N lines, the following recorded data SHALL be included as part of the test report:

- SINGLE_NDRds, SINGLE_SNRpsds, and SINGLE_SNRMds;
- SINGLE_NDRus, SINGLE_SNRpsus, and SINGLE_SNRMus;
- FEXT_NDRds, FEXT_SNRpsds, and FEXT_SNRMds;
- FEXT_NDRus, FEXT_SNRpsus, and FEXT_SNRMus;
- VECTORED_NDRds, VECTORED_SNRpsds, and VECTORED_SNRMds;
- VECTORED_NDRus, VECTORED_SNRpsus, and VECTORED_SNRMus;
- XLINpsds;
- XLINpsus.

8.1.4 Pass/Fail criteria

The following pass/fail criteria for Synchronization, Stability, and Performance SHALL all be met for the test to pass.

Synchronization criteria

All the times indicated below are measured immediately after the last line involved executes the unlock command:

- for single line measurements: each line involved SHALL reach Showtime within 181 seconds;
- for Full FEXT and Vectored measurements: each line involved SHALL reach Showtime within $180 + \text{nextpowerof}2(N)$ seconds.

Stability criteria

No retrains of the vectored lines from the start of MoP(4) until the end of test for all 3 measurements.

Performance criteria

For each of the N lines (line #1 to line #N), the Percent Loss (vectored NDR with respect to single Line NDR) and the Percent Gain (vectored NDR with respect to full FEXT NDR) are determined for upstream and downstream as follows:

$$\text{Percent_loss_us_i} = 100\% * \left(\frac{\text{SINGLE_NDR_us_i} - \text{VECTORED_NDR_us_i}}{\text{SINGLE_NDR_us_i}} \right)$$

$$\text{Percent_gain_us_i} = 100\% * \left(\frac{\text{VECTORED_NDR_us_i} - \text{FEXT_NDR_us_i}}{\text{FEXT_NDR_us_i}} \right)$$

$$\text{Percent_loss_ds_i} = 100\% * \left(\frac{\text{SINGLE_NDR_ds_i} - \text{VECTORED_NDR_ds_i}}{\text{SINGLE_NDR_ds_i}} \right)$$

$$\text{Percent_gain_ds_i} = 100\% * \left(\frac{\text{VECTORED_NDR_ds_i} - \text{FEXT_NDR_ds_i}}{\text{FEXT_NDR_ds_i}} \right)$$

For the test to pass, all of the following 6 performance criteria SHOULD be met:

- $\lfloor 0.90 \times N \rfloor$ lines out of the N lines have:
(Percent_loss_us_i \leq PLMAXus90) OR (Percent_gain_us_i \geq PGMIN);
- $\lfloor 0.90 \times N \rfloor$ lines out of the N lines have:
(Percent_loss_ds_i \leq PLMAXds90) OR (Percent_gain_ds_i \geq PGMIN);
- $\lfloor 0.95 \times N \rfloor$ lines out of the N lines have:
(Percent_loss_us_i \leq PLMAXus95) OR (Percent_gain_us_i \geq PGMIN);
- $\lfloor 0.95 \times N \rfloor$ lines out of the N lines have:
(Percent_loss_ds_i \leq PLMAXds95) OR (Percent_gain_ds_i \geq PGMIN);

- $\lfloor 0.98 \times N \rfloor$ lines out of the N lines have:
(Percent_loss_us_i \leq PLMAXus98) OR (Percent_gain_us_i \geq PGMIN);
- $\lfloor 0.98 \times N \rfloor$ lines out of the N lines have:
(Percent_loss_ds_i \leq PLMAXds98) OR (Percent_gain_ds_i \geq PGMIN);

The minimum percent gain (PGMIN) value SHALL BE 100% for both downstream and upstream, for all percentiles, and for all values of $N \geq 8$.

For $8 \leq N \leq 48$, the maximum percent loss (PLMAX) values for the P90, P95, and P98 percentiles SHALL be as given in Table 19.

Table 19 - PLMAX Values for $8 \leq N \leq 48$

Percentile	Acronym	Downstream	Upstream
P90	PLMAX90_N48	10%	20%
P95	PLMAX95_N48	12%	25%
P98	PLMAX98_N48	20%	35%

For $N > 48$, the PLMAX values SHALL be calculated for all percentile values P90, P95 and P98, starting from the values in Table 19, using Equations (1) and (2).

$$PLMAX_{dsxx}(N) = PLMAX_{dsxx_N48} + 1\% \times \left(\frac{N - 48}{192 - 48} \right) \tag{1}$$

$$PLMAX_{usxx}(N) = PLMAX_{usxx_N48} + 3\% \times \left(\frac{N - 48}{192 - 48} \right) \tag{2}$$

NOTE - Referring to Table 19, the “xx” in the Equations denotes the specific percentile value, the “ds” denotes downstream, and the “us” denotes upstream.

8.2 Collocated Vectoring and Legacy CPEs Test Case (OPTIONAL)

The test setup for testing collocated vectoring and legacy (non- vectoring-friendly) CPEs is illustrated in Figure 6.

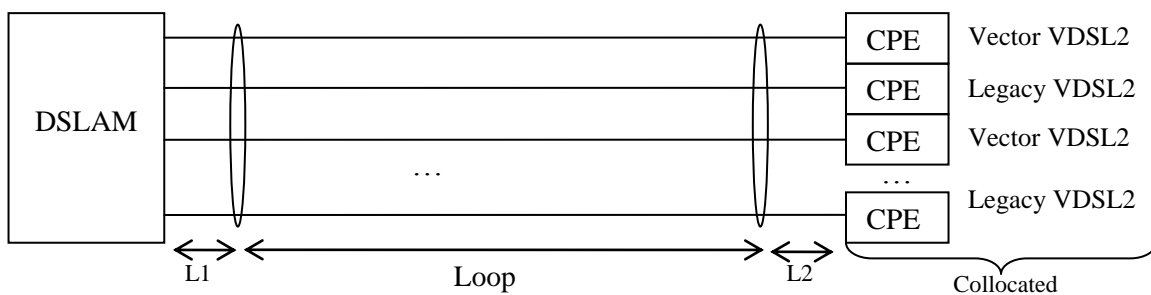

Figure 6 - Test setup for collocated vectoring and legacy CPEs.

8.2.1 Purpose

This test case verifies the vectoring capabilities in the presence of legacy CPEs. It compares the VECTORED performance (VECTORED_NDR) with the NO XTALK performance (SINGLE_NDR) and the FULL FEXT performance (FEXT_NDR), all three measured in the presence of legacy CPEs.

8.2.2 Configuration

The test configuration is described in the following bullets:

- Conditions: The DSLAM and all vectoring CPEs SHALL support vectoring per G.993.5 [4]. The legacy VDSL2 CPEs SHALL support VDSL2 per G.993.2 [3] and SHALL NOT support vectoring or vectoring-friendly operation. At initialization, all VTU-O transceivers connected to a G.993.5 CPE and all G.993.5 VTU-R transceivers SHALL go through the x-P-VECTOR signals.
- Number of lines with a CPE connected: N (numbered 1 to N). With $N_{\text{legacy}} = \text{MAX}(1, \lfloor N/16 \rfloor)$, N-Nlegacy lines SHALL have a G.993.5 CPE connected (i.e., the vectored lines), and Nlegacy lines SHALL have a legacy VDSL2 CPE connected (i.e., the legacy lines). The line numbers to connect the legacy VDSL2 CPEs SHALL be taken from a random draw.
- Profile: One common band profile (defined in Table 8) SHALL be tested. The same profile SHALL be used on all N lines.
- Loops: One loop (short loop or medium loop or long loop as defined in Table 17) SHALL be tested. The loop selected for testing SHALL be included as part of the test report. For each test, all CPEs SHALL be at same loop length from the DSLAM.

8.2.3 Method of procedure

Single line NDR/SNRps/SNRM measurement for each vectored line (N-Nlegacy lines):

1. Lock all N lines;
2. Disable upstream and downstream FEXT cancellation on all N lines;
3. Unlock the Nlegacy legacy lines as quickly as possible per the DSLAM implementation and wait $180 + \text{nextpowerof2}(N_{\text{legacy}})$ seconds after the last line executes the unlock command for these Nlegacy lines to reach Showtime;
4. Unlock the line #i (with line #i being one of the vectored line) and wait 181 seconds for this line to reach Showtime;
5. Wait 1 minute;
6. Record the upstream actual net data rate and downstream actual net data rate (NDR) for line #i (referred to as SINGLE_NDRus_i and SINGLE_NDRds_i) with the Nlegacy legacy lines in Showtime;
7. Record the upstream SNR margin and downstream SNR margin (SNRM) for line #i (referred to as SINGLE_SNRMus_i and SINGLE_SNRMds_i);
8. Lock line #i;

9. Repeat steps 4 to 8 for the other (N-Nlegacy)-1 vectored lines.

Full FEXT NDR/SNRps/SNRM measurement for each vectored line (N-Nlegacy lines):

1. Lock all N lines;
2. Disable upstream and downstream FEXT cancellation on all N lines;
3. Unlock the Nlegacy legacy lines as quickly as possible per the DSLAM implementation and wait $180 + \text{nextpowerof2}(\text{Nlegacy})$ seconds after the last line executes the unlock command for these Nlegacy lines to reach Showtime;
4. Unlock all other N-Nlegacy vectored lines as quickly as possible per the DSLAM implementation and wait $180 + \text{nextpowerof2}(N)$ seconds after the last line executes the unlock command for these N-Nlegacy lines to reach Showtime;
5. Wait $480 + \text{nextpowerof2}(N)$ seconds for SRA to take effect;
6. Record the actual upstream net data rate and actual downstream net data rate (NDR) for all N-Nlegacy vectored lines (referred to as FEXT_NDRus_i and FEXT_NDRds_i, with i = linenumber) while all the N-Nlegacy vectored lines and the Nlegacy legacy lines are in Showtime;
7. Record the upstream SNR margin and downstream SNR margin (SNRM) for all N-Nlegacy vectored lines (referred to as FEXT_SNRMus_i and FEXT_SNRMds_i, with i = linenumber).

Vectored NDR/SNRps/SNRM measurement for each vectored line (N-Nlegacy lines):

1. Lock all N lines;
2. Enable upstream and downstream FEXT cancellation on all N lines;
3. Unlock the Nlegacy legacy lines as quickly as possible per the DSLAM implementation and wait $180 + \text{nextpowerof2}(\text{Nlegacy})$ seconds after the last line executes the unlock command for these Nlegacy lines to reach Showtime;
4. Unlock all other N-Nlegacy as quickly as possible per the DSLAM implementation vectored lines and wait $180 + \text{nextpowerof2}(N)$ seconds after the last line executes the unlock command for these N-Nlegacy lines to reach Showtime;
5. Wait $480 + \text{nextpowerof2}(N)$ seconds for SRA to take effect;
6. Record the actual upstream net data rate and actual downstream net data rate (NDR) for all N-Nlegacy vectored lines (referred to as VECTORED_NDRus_i and VECTORED_NDRds_i, with i = linenumber) while all the N-Nlegacy vectored lines and the Nlegacy legacy lines are in Showtime;
7. Record the upstream SNR margin and downstream SNR margin (SNRM) for all N-Nlegacy vectored lines (referred to as VECTORED_SNRMus_i and VECTORED_SNRMds_i, with i = linenumber);

For all N lines, the following recorded data SHALL be included as part of the test report:

- SINGLE_NDRds and SINGLE_SNRMs;
- SINGLE_NDRus and SINGLE_SNRMus;
- FEXT_NDRds and FEXT_SNRMs;
- FEXT_NDRus and FEXT_SNRMus;
- VECTORED_NDRds and VECTORED_SNRMs;
- VECTORED_NDRus and VECTORED_SNRMus.

8.2.4 Pass/Fail criteria

The following pass/fail criteria for Synchronization, Stability, and Performance SHALL all be met for the test to pass.

Synchronization criteria

All the times indicated below are measured immediately after the last line involved executes the unlock command:

- for single line measurements:
 - each legacy line SHALL reach Showtime within $180 + \text{nextpowerof2}(N_{\text{legacy}})$ seconds;
 - each vectored line SHALL reach Showtime within 181 seconds.
- for Full FEXT and Vectored measurements:
 - each legacy line SHALL reach Showtime within $180 + \text{nextpowerof2}(N_{\text{legacy}})$ seconds;
 - each vectored line SHALL reach Showtime within $180 + \text{nextpowerof2}(N)$ seconds.

If the SUT fails in MOP(3) then retest once.

Stability criteria

No retrains of the vectored lines from the start of MoP(5) until the end of test for all 3 measurements.

Performance criteria

For the test to pass, the 6 performance criteria defined in section 8.1.4 SHOULD be met, with replacing “N” with “N-N_{legacy}”.

8.3 Collocated Vectoring and vectoring-friendly CPEs Test Case (OPTIONAL)

The test setup for testing collocated vectoring and vectoring-friendly CPEs is illustrated in Figure 7.

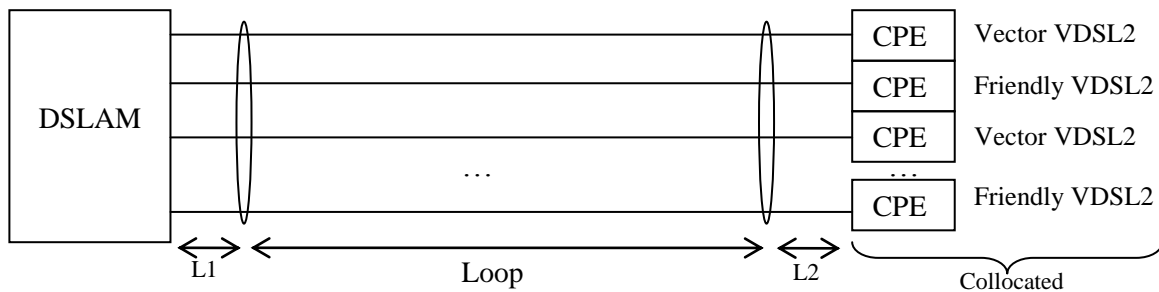

Figure 7 - Test setup for collocated vectoring and vectoring-friendly CPEs.

8.3.1 Purpose

This test case verifies the vectoring capabilities in the presence of vectoring-friendly CPEs. It compares the downstream VECTORED performance (VECTORED_NDRds) with the NO XTALK performance (SINGLE_NDRds) and the FULL FEXT performance (FEXT_NDRds).

8.3.2 Configuration

The test configuration is described in the following bullets:

- Conditions: The DSLAM and all vectoring CPEs SHALL support vectoring per G.993.5 [4]. The vectoring-friendly CPEs SHALL support VDSL2 per G.993.2 [3] with vectoring-friendly operation enabled per G.993.2 Annex Y, and SHALL NOT support vectoring per G.993.5. At initialization, all VTU-O transceivers connected to a G.993.5 CPE and all G.993.5 VTU-R transceivers SHALL go through the x-P-VECTOR signals.
- Number of lines with a CPE connected: N (numbered 1 to N). With $N_{friendly} = \text{MAX}(1; \lfloor N/4 \rfloor)$, $N - N_{friendly}$ lines SHALL have a G.993.5 CPE connected (i.e., the vectored lines), and $N_{friendly}$ lines SHALL have a vectoring-friendly CPE connected (i.e., the friendly lines). The line numbers to connect the vectoring-friendly CPEs SHALL be taken from a random draw.
- Profile: One common band profile (defined in Table 8) SHALL be tested. The same profile SHALL be used on all N lines.
- Loops: One loop (short loop or medium loop or long loop defined in Table 17) SHALL be tested. The loop selected for testing SHALL be included as part of the test report. For all tests, all CPEs SHALL be at same loop length from the DSLAM.

8.3.3 Method of procedure

Single line NDR/SNRps/SNRM measurement for each vectored line (N-Nfriendly lines):

Use values previously recorded in section 8.1.3 for single line NDR/SNRps/SNRM for the same loop.

Full FEXT NDR/SNRps/SNRM measurement for each vectored line (N-Nfriendly lines):

1. Lock all N lines;

2. Disable upstream and downstream FEXT cancellation on all N lines;
3. Unlock all N lines as quickly as possible per the DSLAM implementation and wait $180 + \text{nextpowerof2}(N)$ seconds after the last line executes the unlock command for these N lines to reach Showtime;
4. Wait $480 + \text{nextpowerof2}(N)$ seconds for SRA to take effect;
5. Record the actual upstream net data rate and actual downstream net data rate (NDR) for all N-Nfriendly vectored lines (referred to as FEXT_NDRds_i, with i = linenumber) with the N-Nfriendly vectored lines and the Nfriendly friendly lines in Showtime;
6. Record the upstream SNR margin and downstream SNR margin (SNRM) for all N-Nfriendly vectored lines (referred to as FEXT_SNRMds_i, with i = linenumber);

Vectored NDR/SNRps/SNRM measurement for each vectored line (N-Nfriendly lines):

1. Lock all N lines;
2. Enable upstream and downstream FEXT cancellation on all N lines;
3. Unlock all N lines as quickly as possible per the DSLAM implementation and wait $180 + \text{nextpowerof2}(N)$ seconds after the last line executes the unlock command for these N lines to reach Showtime;
4. Wait $480 + \text{nextpowerof2}(N)$ seconds for SRA to take effect;
5. Record the actual upstream net data rate and actual downstream net data rate (NDR) for all N-Nfriendly vectored lines (referred to as VECTORED_NDRds_i, with i = linenumber) with the N-Nfriendly vectored lines and the Nfriendly friendly lines in Showtime;
6. Record the upstream SNR margin and downstream SNR margin (SNRM) for all N-Nfriendly lines (referred to as VECTORED_SNRMds_i, with i = linenumber);

For all N lines, the following recorded data SHALL be included as part of the test report:

- FEXT_NDRds and FEXT_SNRMds;
- FEXT_NDRus and FEXT_SNRMus;
- VECTORED_NDRds and VECTORED_SNRMds;
- VECTORED_NDRus and VECTORED_SNRMus;

8.3.4 Pass/Fail criteria

The following pass/fail criteria for Synchronization, Stability, and Performance SHALL all be met for the test to pass.

Synchronization criteria

All the times indicated below are measured immediately after the last line involved executes the unlock command:

- for Full FEXT and Vectored measurements:

- each line SHALL reach Showtime within $180 + \text{nextpowerof2}(N)$ seconds.

Stability criteria

No retrains of the vectored lines from the start of MoP(5) until the end of test for both measurements.

Performance criteria

For the test to pass, the 3 downstream performance criteria defined in section 8.1.4 SHOULD be met over the set of N-Nfriendly vectored lines.

8.4 Non-Collocated Vectoring CPEs Test Case (2 loop lengths)

The test setup for testing non-collocated vectoring CPEs is illustrated in Figure 8.

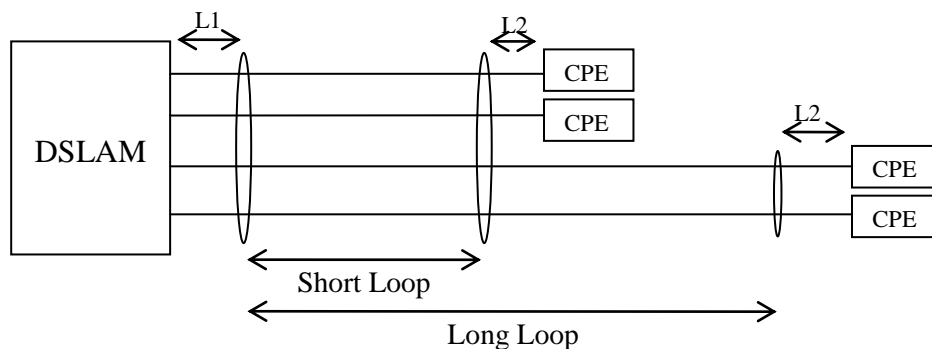

Figure 8 - Test setup for non-collocated vectoring CPEs (2 loop lengths).

8.4.1 Purpose

This test case verifies the vectoring capabilities of the SUT in case all CPEs support vectoring and are non-collocated on 2 different loop lengths. It compares the VECTORED performance (VECTORED_NDR) with the NO XTALK performance (SINGLE_NDR) and the FULL FEXT performance (FEXT_NDR).

8.4.2 Configuration

The test configuration is described in the following bullets:

- Conditions: The DSLAM and all CPEs SHALL support vectoring per G.993.5 [4]. At initialization, all VTU-O and all VTU-R transceivers SHALL go through the x-P-VECTOR signals.
- Number of lines with a CPE connected: N (numbered 1 to N, with N a multiple of 2). Line #1 to line #N have a G.993.5 CPE connected.
- Profile: One common band profile (defined in Table 8) SHALL be tested. The same profile SHALL be used on all N lines.

- Loops: N/2 CPEs SHALL be connected to DSLAM over a short loop and N/2 SHALL be connected over a long loop (defined in Table 17).

8.4.3 Method of procedure

Single line NDR/SNRps/SNRM measurement for each line:

Use values previously recorded in section 8.1.3 for single line NDR/SNRps/SNRM for the same loop.

Full FEXT NDR/SNRps/SNRM measurement for each line:

See method of procedure in section 8.1.3, without recording of SNRps and XLINps.

Vectored NDR/SNRps/SNRM measurement for each line:

See method of procedure in section 8.1.3, without recording of SNRps and XLINps.

For all N lines, the following recorded data SHALL be included as part of the test report:

- FEXT_NDRds and FEXT_SNRMds;
- FEXT_NDRus and FEXT_SNRMus;
- VECTORED_NDRds and VECTORED_SNRMds;
- VECTORED_NDRus and VECTORED_SNRMus;

8.4.4 Pass/Fail criteria

The following pass/fail criteria for Synchronization, Stability, and Performance SHALL all be met for the test to pass.

Synchronization criteria

All the times indicated below are measured immediately after the last line involved executes the unlock command:

- for Full FEXT and Vectored measurements: each line involved SHALL reach Showtime within $180 + \text{nextpowerof2}(N)$ seconds.

Stability criteria

No retrains of the vectored lines from the start of MoP(4) until the end of test for both measurements.

Performance criteria

For the test to pass, the 6 performance criteria defined in section 8.1.4 SHOULD be met.

8.5 Non-Collocated Vectoring CPE Test Case (3 loop lengths)

The test setup for testing non-collocated vectoring CPEs is illustrated in Figure 9.

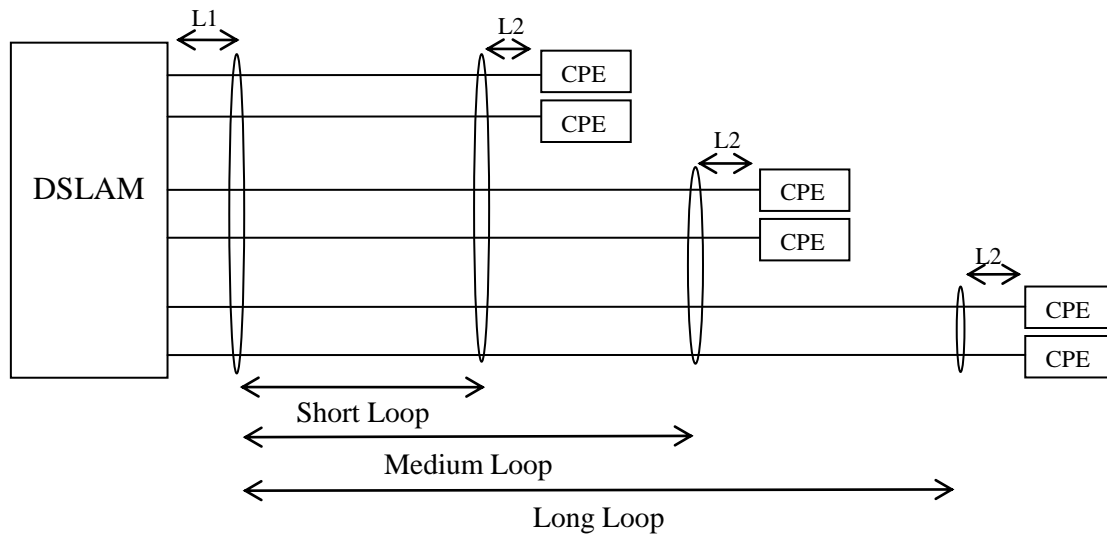

Figure 9 - Test setup for non-located vectoring CPEs (3 loop lengths).

8.5.1 Purpose

This test case verifies the vectoring capabilities in case all CPEs support vectoring and are non-located on 3 different loop lengths. It compares the VECTORED performance (VECTORED_NDR) with the NO XTALK performance (SINGLE_NDR) and the FULL FEXT performance (FEXT_NDR).

8.5.2 Configuration

The test configuration is described in the following bullets:

- Conditions: The DSLAM and all CPEs SHALL support vectoring per G.993.5 [4]. At initialization, all VTU-O and all VTU-R transceivers SHALL go through the x-P-VECTOR signals.
- Number of lines with a CPE connected: N (numbered 1 to N, with N a multiple of 3). Line #1 to line #N have a G.993.5 CPE connected.
- Profile: One common band profile (defined in Table 8) SHALL be tested. The same profile SHALL be used on all N lines.
- Loops: N/3 CPEs SHALL be connected to DSLAM over a short loop, N/3 CPEs SHALL be connected over a medium loop, and N/3 CPEs SHALL be connected to DSLAM over a long loop (defined in Table 17).

8.5.3 Method of procedure

Single line NDR/SNRps/SNRM measurement for each line:

Use values previously recorded in section 8.1.3 for single line NDR/SNRps/SNRM for the same loop.

Full FEXT NDR/SNRps/SNRM measurement for each line:

See method of procedure in section 8.1.3, without recording of SNRps and XLINps.

Vectored NDR/SNRps/SNRM measurement for each line:

See method of procedure in section 8.1.3, without recording of SNRps and XLINps.

For all N lines, the following recorded data SHALL be included as part of the test report:

- FEXT_NDRds and FEXT_SNRMds;
- FEXT_NDRus and FEXT_SNRMus;
- VECTORED_NDRds and VECTORED_SNRMds;
- VECTORED_NDRus and VECTORED_SNRMus;

8.5.4 Pass/Fail criteria

The following pass/fail criteria for Synchronization, Stability, and Performance SHALL all be met for the test to pass.

Synchronization criteria

All the times indicated below are measured immediately after the last line involved executes the unlock command:

- for Full FEXT and Vectored measurements: each line involved SHALL reach Showtime within $180 + \text{nextpowerof2}(N)$ seconds.

Stability criteria

No retrains of the vectored lines from the start of MoP(4) until the end of test for both measurements.

Performance criteria

For the test to pass, the 6 performance criteria defined in section 8.1.4 SHOULD be met.

8.6 RFI Noise Test Case

For further study.

8.7 Long Term Stability Test Case

The test setup is illustrated in Figure 5.

8.7.1 Purpose

This test case verifies the long term stability of the vectored system.

8.7.2 Configuration

The configuration is defined in section 8.1.2, with testing only on a short loop. The line number (i) on which the long term stability is tested SHALL be taken from a random draw.

8.7.3 Method of procedure

Vectored Performance Monitoring (PM) measurement for each line:

1. Lock all N lines;
2. Enable upstream and downstream FEXT cancellation on all N lines;
3. Unlock all N lines as quickly as possible per the DSLAM implementation and wait $180 + \text{nextpowerof2}(N)$ seconds after the last line executes the unlock command for all N lines to reach Showtime;
4. Wait $480 + \text{nextpowerof2}(N)$ seconds for SRA to take effect;
5. Force performance monitoring counters update and wait 30 seconds for the full initialization count to be updated;
6. Record the full initialization count for line #i (referred to as BEFORE_full-init_counter);
7. Record the upstream errored seconds count and the downstream errored seconds count (ES) for line #i (referred to as BEFORE_ES-L and BEFORE_ES-LFE);
8. Record the actual upstream net data rate and actual downstream net data rate (NDR) for line #i (referred to as VECTORED_NDRus and VECTORED_NDRds);
9. Record the upstream SNR margin and downstream SNR margin (SNRM) for line #i (referred to as VECTORED_SNRMus and VECTORED_SNRMds);
10. Run for a four hours test duration and every 15 minutes, record the upstream errored seconds count and downstream errored seconds count (ES) for line #i (referred to as AFTER_ES-L and AFTER_ES-LFE) (16 values to be recorded);
11. If there are more than 2 downstream errored seconds (ES-LFE) on line #i over the test duration, then the test duration SHALL be extended for up to an additional four-hour period (for a maximum of 8 hours);
12. Force performance monitoring counters update and wait 30 seconds for the full initialization count to be updated;
13. Record the full initialization count for line #i (referred to as AFTER_full-init_counter).

The following recorded data SHALL be included as part of the test report:

- BEFORE_full-init_counter and AFTER_full-init_counter;
- VECTORED_NDRds and VECTORED_SNRMds;
- VECTORED_NDRus and VECTORED_SNRMus.
- ES-L and ES-LFE for each 15-minute interval within the test duration (at least 16 and up to 32 values).

8.7.4 Pass/Fail criteria

For the test to pass,:

1. AFTER_full-init_counter = BEFORE_full-init_counter;

2. Over 16 consecutive 15-minute intervals within the test duration:
(AFTER_ES-LFE - BEFORE_ES-LFE) \leq 2.

9 Functional Testing of Vectored Systems

9.1 Vectoring Support for Different Profiles Test Case

The test setup for testing vectoring support for different profiles is illustrated in Figure 5.

9.1.1 Purpose

Verify that vectoring is performed when ports are assigned different VDSL2 profiles within the same band plan and sub-carrier spacing. The set of valid combinations of profiles is provided in Table 20 and it is based on the 12a and 17a common band profiles defined in Table 8.

Table 20 - Common Combined Band Profiles

12a common band profiles	17a common band profiles			
	AA17a	BA17a	BB17a	BA17ADE
AA12a	X	N/A	N/A	N/A
BA12a	N/A	X	N/A	X
BB12a	N/A	N/A	X	N/A

9.1.2 Configuration

The test configuration is described in the following bullets:

- Conditions: The DSLAM and all CPEs SHALL support vectoring per G.993.5 [4]. At initialization, all VTU-O and all VTU-R transceivers SHALL go through the x-P-VECTOR signals.
- Number of lines with a CPE connected: N (numbered 1 to N, with N a multiple of 2). Line #1 to line #N have a G.993.5 CPE connected.
- Profile: One common combined band profile defined in Table 20 SHALL be tested. Line #1 to line #(N/2) SHALL be configured with a profile 17a. Line#(N/2+1) to line #N SHALL be configured with a profile 12a.
- Loops: Testing SHALL be performed over 3 loops (short loop and medium loop and long loop as defined in Table 17). For each test, all CPEs SHALL be at same loop length from the DSLAM. The pass/fail criteria SHALL be met for each tested loop separately.

9.1.3 Method of procedure

Full FEXT NDR measurement for each line:

1. Lock all N lines;
2. Disable upstream and downstream FEXT cancellation on all N lines;

3. Unlock all N lines as quickly as possible per the DSLAM implementation and wait $180 + \text{nextpowerof2}(N)$ seconds after the last line executes the unlock command for all N lines to reach Showtime;
4. Wait $480 + \text{nextpowerof2}(N)$ seconds for SRA to take effect;
5. Record the actual upstream net data rate and actual downstream net data rate (NDR) for all N lines (referred to as FEXT_NDRds_i and FEXT_NDRus_i, with i = linenumber 1 to N).
6. Record the upstream SNR margin and downstream SNR margin (SNRM) for all N lines (referred to as FEXT_SNRMus_i and FEXT_SNRMds_i, with i = linenumber 1 to N);

Vectored NDR measurement for each line:

1. Lock all N lines;
2. Enable upstream and downstream FEXT cancellation on all N lines;
3. Unlock all N lines as quickly as possible per the DSLAM implementation and wait $180 + \text{nextpowerof2}(N)$ seconds after the last line executes the unlock command for all N lines to reach Showtime;
4. Wait $480 + \text{nextpowerof2}(N)$ seconds for SRA to take effect;
5. Record the actual upstream net data rate and actual downstream net data rate (NDR) for all N lines (referred to as VECTORED_NDRds_i and VECTORED_NDRus_i with i = linenumber 1 to N);
6. Record the upstream SNR margin and downstream SNR margin (SNRM) for all N lines (referred to as VECTORED_SNRMus_i and VECTORED_SNRMds_i, with i = linenumber 1 to N).

For all N lines, the following recorded data SHALL be included as part of the test report:

- FEXT_NDRds and FEXT_SNRMds;
- FEXT_NDRus and FEXT_SNRMus;
- VECTORED_NDRds and VECTORED_SNRMds;
- VECTORED_NDRus and VECTORED_SNRMus.

9.1.4 Pass/Fail criteria

The following pass/fail criteria for Synchronization, Stability, and Performance SHALL all be met for the test to pass.

Synchronization criteria

All the times indicated below are measured immediately after the last line involved executes the unlock command:

- for Full FEXT and Vectored measurements: each line involved SHALL reach Showtime within $180 + \text{nextpowerof2}(N)$ seconds.

Stability criteria

No retrains of the vectored lines from the start of MoP(4) until the end of test for both measurements.

Performance criteria

Each line (line #1 to line #N) SHALL have:

- $VECTORED_NDRus_i \geq FEXT_NDRus_i$.
- $VECTORED_NDRds_i \geq FEXT_NDRds_i$.

9.2 Activation and disorderly shutdown of lines in a vectored group

9.2.1 Purpose

The purpose of this test is to:

- Verify that other lines do not retrain when lines in the vectored group are removed (disorderly leaving event).
- Verify that other lines do not retrain when lines in the vectored group activate (joining event).

9.2.2 Configuration

The configuration is defined in section 8.1.2.

A disorderly leaving event SHALL be forced on the line by disconnecting the line manually or using a relay contact. For each test, a disorderly leaving event SHALL be forced onto three lines (see section 9.2.3). The line numbers (i1, i2, and i3) on which a disorderly leaving event is forced SHALL be taken from a random draw.

9.2.3 Method of procedure

Perform leaving and joining events:

1. Lock all N lines;
2. Enable upstream and downstream FEXT cancellation on all N lines;
3. Unlock all N lines as quickly as possible per the DSLAM implementation and wait $180 + \text{nextpowerof2}(N)$ seconds after the last line executes the unlock command for the N lines to reach Showtime;
4. Wait $480 + \text{nextpowerof2}(N)$ seconds for SRA to take effect;
5. Force performance monitoring counters update and wait 30 seconds for the full initialization count to be updated;
6. Record the full initialization count for all N lines (referred to as `BEFORE_full-init_counter_i`, with $i = \text{linenumber } 1 \text{ to } N$);
7. Disconnect line #i1 at CPE side;

8. Wait $480 + \text{nextpowerof2}(N)$ seconds for SRA to take effect;
9. Force performance monitoring counters update and wait 30 seconds for the full initialization count to be updated;
10. Record the full initialization count for all N lines (referred to as AFTER_full-init_counter_i, with i=linenumber, and i = 1 to N, with i≠1);
11. Disconnect an additional line #i2 and line #i3 at CPE side;
12. Repeat step 8 to 10 (with lines #i1, #i2, and #i3 disconnected);
13. Reconnect line #i1;
14. Wait $180 + \text{nextpowerof2}(N)$ seconds for the reconnected line to reach Showtime;
15. Repeat steps 8-10 (with lines #i2 and #i3 disconnected);
16. Reconnect lines #i2 and #i3;
17. Wait $180 + \text{nextpowerof2}(N)$ seconds for the two reconnected lines to reach Showtime;
18. Repeat steps 8-10 (without disconnected lines).

For all N lines, except lines #i1, #i2, and #i3, the following recorded data SHALL be included as part of the test report:

- BEFORE_Full-init_counter;
- After disconnecting line #i1: AFTER_Full-init_counter;
- After disconnecting line #i2 and line #i3: AFTER_Full-init_counter;
- After reconnecting line #i1: AFTER_Full-init_counter;
- After reconnecting line #i2 and line #i3: AFTER_Full-init_counter;

9.2.4 Pass/Fail criteria

For the test to pass, each of line #1 to line #N, except lines #i1, #i2, and #i3, SHALL have:

- AFTER_full-init_counter_i = BEFORE_full-init_counter_i

9.3 Micro-Interruption Test Case

The test setup is illustrated in Figure 10.

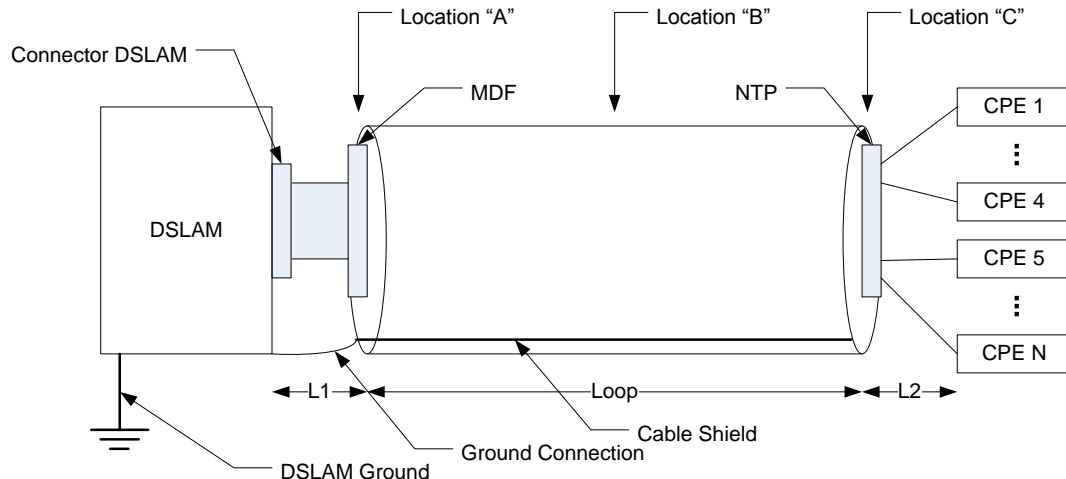

Figure 10 - Test setup for the micro-interruption test.

The following Interruption Locations are defined:

- A At the begin of the loop section, after L1;
- B At one point between 40 - 60 % of the loop length;
- C At the end of the loop section, before L2.

There are 3 types of micro-interruptions. A Type-1 micro-interruption is modeled as an open circuit on both wires on a wire pair. A Type-2 micro-interruption is a micro-cut - open circuit - on the Tip (T) wire. A Type-3 micro-interruption is a micro-cut - open circuit - on the Ring (R) wire. In carrying out the tests with micro-interruptions, Type-1 micro-interruption SHALL be tested with pass/fail criteria. Type-2 and Type-3 micro-interruptions SHOULD also be tested without pass/fail criteria. Furthermore, there are other mechanical interruptions which may affect performance. These include a micro-short across both Tip and Ring wires and finite impedance discontinuities at discrete points on one or both wires. The effect of these other mechanical interruptions on performance is for further study.

For each test, a micro-interruption SHALL be forced onto three lines (see section 8.7.3). The line numbers (i1, i2, and i3) on which a micro-interruption is forced SHALL be taken from a random draw.

9.3.1 Purpose

This test case shows the error reporting capability of the vectored system and the stability of the vectoring system by forcing micro-interruptions on selected lines.

9.3.2 Configuration

The test configuration is described in the following bullets:

- Conditions: The DSLAM and all CPEs SHALL support vectoring per G.993.5 [4]. At initialization, all VTU-O and all VTU-R transceivers SHALL go through the x-P-VECTOR signals.

- Number of lines with a CPE connected: N (numbered 1 to N). Line #1 to line #N have a G.993.5 CPE connected.
- Profile: One common band profile (defined in Table 8) SHALL be tested. The same profile line combination (defined in Table 16) SHALL be used on all N lines.
- Two tests SHALL be performed (short loop and long loop are defined in Table 17) and both tests SHALL be passed. For each test, all CPEs SHALL be at same loop length from the DSLAM.
 - Test 1: Micro-interruption first at location C then at location A on a short loop;
 - Test 2: Micro-interruption at location B on a long loop.

9.3.3 Method of procedure

Vectored Performance Monitoring (PM) measurement for each line:

1. Lock all N lines;
2. Enable upstream and downstream FEXT cancellation on all N lines;
3. Unlock all N lines as quickly as possible per the DSLAM implementation and wait $180 + \text{nextpowerof2}(N)$ seconds after the last line executes the unlock command for all N lines to reach Showtime;
4. Wait $480 + \text{nextpowerof2}(N)$ seconds for SRA to take effect;
5. Force performance monitoring (PM) counters update and wait 30 seconds for the counters to be updated;
6. Record the number of upstream CRC errors and downstream CRC errors (CV) for all N lines (referred to as BEFORE_CV-C_i and BEFORE_CV-CFE_i, with i=linenumber 1 to N);
7. Record the number of upstream severely errored seconds and downstream severely errored seconds (SES) for all N lines (referred to as BEFORE_SES-L_i and BEFORE_SES-LFE_i, with i=linenumber 1 to N);
8. Record the full initialization count for all N lines (referred to as BEFORE_full-init_counter_i, with i=linenumber 1 to N);
9. Force a micro-interruption on line #i1, at the Interruption Location (if the test has two Interrupt Locations, interrupt at the first location), and with duration of 9 ± 0.5 ms;
10. If the test has two Interrupt Locations, after 5 seconds, force a micro-interruption on line #i1, at the second Interrupt Location, and with duration of 9 ± 0.5 ms;
11. Repeat step 9 and 10 every 10 seconds, for a total of 12 micro-interruptions issued at each Interrupt Location;
12. Force performance monitoring (PM) counters update and wait 30 seconds for the counters to be updated;

13. Record the number of upstream CRC errors and downstream CRC errors (CV) for all N lines (referred to as AFTER_CV-C_i and AFTER_CV-CFE_i, with i=linenumber 1 to N);
14. Record the number of upstream severely errored seconds and downstream severely errored seconds (SES) for all N lines (referred to as AFTER_SES-L_i and AFTER_SES-LFE_i, with i=linenumber 1 to N);
15. Record the full initialization count for all N lines (referred to as AFTER_full-init_counter_i, with i=linenumber 1 to N);
16. Repeat steps 9 to 15 for line #i2;
17. Repeat steps 9 to 15 for line #i3;

For all N lines, the following recorded data SHALL be included as part of the test report:

- BEFORE_CV-CFE and BEFORE_CV-C;
- BEFORE_SES-LFE and BEFORE_SES-L;
- BEFORE_Full-init_counter;
- After applying micro-interruptions on line #i1:
 - AFTER_CV-CFE and AFTER_CV-C;
 - AFTER_SES-LFE and AFTER_SES-L;
 - AFTER_Full-init_counter;
- After applying micro-interruptions on line #i2:
 - AFTER_CV-CFE and AFTER_CV-C;
 - AFTER_SES-LFE and AFTER_SES-L;
 - AFTER_Full-init_counter;
- After applying micro-interruptions on line #i3:
 - AFTER_CV-CFE and AFTER_CV-C;
 - AFTER_SES-LFE and AFTER_SES-L;
 - AFTER_Full-init_counter;

9.3.4 Pass/Fail criteria

For the test to pass,

- AFTER_full-init_counter_i = BEFORE_full-init_counter_i, for line #1 to line #N;
- AFTER_SES-L_i = BEFORE_SES-L_i, for line #1 to line #N;
- AFTER_SES-LFE_i = BEFORE_SES-LFE_i, for line #1 to line #N;

9.4 Single Wire-Interruption Test Case

The test setup for the single wire-interruption test is the same as for the micro-interruption test defined in section 8.7.

A single wire-interruption SHALL be modeled as an insertion of a 10pF capacitor on one wire of the wire-pair (see Figure 11). It SHALL be forced on the line manually or using a relay contact. For each test, a single wire-interruption SHALL be forced onto three lines (see section 9.3.3).

The line numbers (i1, i2, and i3) on which a single wire-interruption is forced SHALL be taken from a random draw.

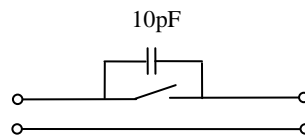

Figure 11 - Model of a single wire-interruption.

9.4.1 Purpose

The purpose of the test is to check if the system behaves as expected when one wire of a line in the vectored group is interrupted (single wire-interruption). It is expected that the vectoring line reaches Showtime even with only one connected wire while the interrupted section of the second wire is bridged via capacitive couplings to adjacent wires. When the contact of the broken wire is repaired or is intermittent while the DSLAM or CPE continues to transmit then sudden significant changes of the transmit PSD on the line may occur which can severely affect other lines of the vectoring group within the same cable.

9.4.2 Configuration

The configuration for the single wire-interruption test case is the same as for the micro-interruption test case defined in section 8.7.2.

In total, three tests SHALL be performed on two loops (short loop and long loop are defined in Table 17) and all three tests SHALL be passed. For each test, all CPEs SHALL be at same loop length from the DSLAM.

- Test 1: Single wire-interruption at location A on a short loop;
- Test 2: Single wire-interruption at location C on a short loop;
- Test 3: Single wire-interruption at location B on a long loop.

9.4.3 Method of procedure

Vectored Performance Monitoring (PM) measurement for each line:

1. Lock all N lines;
2. Enable upstream and downstream FEXT cancellation on all N lines;
3. Unlock all N lines as quickly as possible per the DSLAM implementation and wait up to $180 + \text{nextpowerof2}(N)$ seconds after the last line executes the unlock command for all N lines to reach Showtime;
4. Wait $480 + \text{nextpowerof2}(N)$ seconds for SRA to take effect;
5. Force performance monitoring (PM) counters update and wait 30 seconds for the full initialization count to be updated;

6. Record the full initialization count for all N lines (referred to as BEFORE_full-init_counter_i, with i=linenumber 1 to N);
7. Force single wire-interruption on line #i1 at the Interruption Location applicable to the test;
8. Wait $180 + \text{nextpowerof2}(N)$ seconds for all n lines (n ranges from 1 to N) that retrained after step 7 (including the interrupted line) to reach Showtime.

NOTE - It is expected that the interrupted line reaches Showtime even with only one connected wire while the interrupted section of the second wire is bridged via capacitive couplings to adjacent wires.
9. Reconnect the wire for line #i1 at the Interruption Location applicable to the test;
10. Wait $180 + \text{nextpowerof2}(N)$ seconds for the all m lines (m ranges from 1 to N) that left Showtime after step 9 (including the interrupted line) to reach Showtime;
11. Force performance monitoring (PM) counters update and wait 30 seconds for the full initialization count to be updated;
12. Record the full initialization count for all N lines (referred to as AFTER_full-init_counter_i, with i=linenumber 1 to N);
13. Repeat steps 7 to 10 with forcing the single wire-interruption on line #i2;
14. Repeat steps 7 to 10 with forcing the single wire-interruption on line #i3.

For all N lines, except the lines #i1, #i2, and #i3, the following recorded data SHALL be included as part of the test report:

- BEFORE_Full-init_counter;
- After reconnection of line #i1: AFTER_Full-init_counter;
- After reconnection of line #i2: AFTER_Full-init_counter;
- After reconnection of line #i3: AFTER_Full-init_counter.

9.4.4 Pass/Fail criteria

For the test to pass, there SHALL be no increase of the full initialization count from step 6 to step 14:

- AFTER_full-init_counter_i = BEFORE_full-init_counter_i, for line #1 to line #N, except the lines #i1, #i2, and #i3.

10 Testing Reporting of Parameters Defined in G.997.1

This section defines tests to validate functionality of the G.993.5 [4] related parameters defined in G.997.1 [6].

10.1 Vectoring Mode Enable (VECTORMODE_ENABLE) Test Case (OPTIONAL)

10.1.1 Purpose

The purpose of this test case is to check whether the Vectored lines initialize as expected when they are configured with a given set of vectoring initialization types to be allowed by the VTU-O on the line (see section 7.3.1.13.9 in G.997.1 [6]) and connected to CPEs which may or may not belong to the configured set.

10.1.2 Configuration

The test configuration is described in the following bullets:

- Conditions: The DSLAM supports vectoring per G.993.5 [4] and supports G.993.2 [3]. In addition to G.993.5 and G.993.2, the DSLAM MAY also support G.993.2 Annex X and/or G.993.2 Annex Y.
- CPE types: This test is performed on 4 lines. A different CPE type SHALL be connected to each line supporting the following vectored modes of operation:
 - [CPE#1 on Line#1] supports G .993.2;
 - [CPE#2 on Line#2] supports G.993.2 including Annex X;
 - [CPE#3 on Line#3] supports G.993.2 including Annex Y;
 - [CPE#4 on Line#4] supports G.993.5.
- Profile: Line#1 to Line#4 SHALL be configured with the same common band profile (defined in Table 8). The same specific line settings (defined in Table 15) SHALL be used on all lines.
- Loops: One loop (short loop or medium loop or long loop as defined in Table 17) SHALL be tested. For each test, all CPEs SHALL be at same loop length from the DSLAM.
- The test is conceived in 4 Phases, before each Phase the VECTORMODE_ENABLE parameter (see clause 7.3.1.13.9 of G.997.1 [6]) SHALL be configured as defined in Table 21.

Table 21 - VECTORMODE_ENABLE parameter settings

Test Case phase	VECTORMODE_ENABLE Bits			
	0	1	2	3
Phase 1	1	1	1	1
Phase 2	0	1	1	1
Phase 3	0	0	1	1
Phase 4	0	0	0	1

10.1.3 Method of procedure

For each of the 4 Phases:

1. Lock all 4 lines;
2. Configure all 4 lines as indicated in Table 21, referring to the test Phase being performed;
3. Unlock all 4 lines as quickly as possible per the DSLAM implementation and wait 184 seconds;
4. Record the line power management state of each line; for those lines that reached the L0 state, record also the mode of operation.

For each of the 4 lines, the following recorded data SHALL be included as part of the test report:

- Phase 1 line power management state and mode of operation;
- Phase 2 line power management state and mode of operation;
- Phase 3 line power management state and mode of operation;
- Phase 4 line power management state and mode of operation.

10.1.4 Pass/Fail criteria

The Pass/Fail criteria are specified in Table 22 below on a Phase by Phase and line by line basis. All 16 phase/line combinations SHALL be passed, except when the expected result is not supported by the DSLAM.

Table 22 - Pass/Fail criteria for the VECTORMODE_ENABLE test

Test Case phase	Line #	Expected result	
		Line in L0 state	Mode of operation (if supported by DSLAM)
Phase 1	1	YES	G.993.2
	2	YES	G.993.2 Annex X
	3	YES	G.993.2 Annex Y
	4	YES	G.993.5
Phase 2	1	NO	N/A
	2	YES	G.993.2 Annex X
	3	YES	G.993.2 Annex Y
	4	YES	G.993.5
Phase 3	1	NO	N/A
	2	NO	N/A
	3	YES	G.993.2 Annex Y
	4	YES	G.993.5
Phase 4	1	NO	N/A
	2	NO	N/A
	3	NO	N/A
	4	YES	G.993.5

I Appendix I Noise Injection

This Appendix is for information only. It describes a possible method of noise injection with some performance considerations and impedance requirements for the injector circuitry.

The actual method for noise injection also needs to take into account requirements for the noise correlation between the various noise sources and common mode levels, with respect to each of the N lines connecting the DSLAM and the CPEs. These aspects are not addressed in this Appendix.

The circuit topology for multiport noise injection is for further study.

The Thevenin impedance of all differential noise-coupling circuits connected to the test loop SHOULD be greater than 4000 Ohms at the point of injection, referred to a 100 Ohm impedance point (see clause 5.1.2.1 of G.996.1 [5]) for a frequency range from 20 kHz to 30 MHz.

The method of noise injection SHOULD allow multiple and individual noises to be injected, simultaneously, on n lines, with n at least two, and the following requirements SHOULD be met:

- 1) For each of the $n \times (n-1)/2$ pairs of injector ports of a multiple loop noise injection system, the isolation between the two ports SHOULD be at least 80 dB. For a given pair of injector ports, the method of verification SHOULD be to inject a swept sine wave from a network analyzer into the first port, measure the injector output corresponding to that port as a 0 dB reference, and then measure the resulting signal output of that swept sine wave on the second port. The absolute value of the measured level below the 0 dB reference on the second port is the isolation.
- 2) The method of noise injection SHOULD allow simultaneous injection of noises on multiple loops where the noise is correlated between loops.

The multiple loop noise injection method MAY allow for independent and individual noises to be injected on different loops simultaneously.

End of Broadband Forum Technical Report TR-249