

TR-197

DQS: DSL Quality Management Techniques and Nomenclature

Issue: 2
Issue Date: December 2014

Notice

The Broadband Forum is a non-profit corporation organized to create guidelines for broadband network system development and deployment. This Broadband Forum Technical Report has been approved by members of the Forum. This Broadband Forum Technical Report is not binding on the Broadband Forum, any of its members, or any developer or service provider. This Broadband Forum Technical Report is subject to change, but only with approval of members of the Forum. This Technical Report is copyrighted by the Broadband Forum, and all rights are reserved. Portions of this Technical Report may be copyrighted by Broadband Forum members.

The Forum draws attention to the fact that it is claimed that compliance with this Specification may involve the use of a patent ("IPR") concerning TR-197 Issue 2. The Forum takes no position concerning the evidence, validity or scope of this IPR.

The holder of this IPR has assured the Forum that it is willing to License all IPR it owns and any third party IPR it has the right to sublicense which might be infringed by any implementation of this Specification to the Forum and those Licensees (Members and non-Members alike) desiring to implement this Specification. Information may be obtained from:

Adaptive Spectrum and Signal Alignment, Inc.
333 Twin Dolphin Drive, Redwood City, CA 94065, USA

Attention is also drawn to the possibility that some of the elements of this Specification may be the subject of IPR other than those identified above. The Forum shall not be responsible for identifying any or all such IPR.

THIS SPECIFICATION IS BEING OFFERED WITHOUT ANY WARRANTY WHATSOEVER, AND IN PARTICULAR, ANY WARRANTY OF NONINFRINGEMENT IS EXPRESSLY DISCLAIMED. ANY USE OF THIS SPECIFICATION SHALL BE MADE ENTIRELY AT THE IMPLEMENTER'S OWN RISK, AND NEITHER the Forum, NOR ANY OF ITS MEMBERS OR SUBMITTERS, SHALL HAVE ANY LIABILITY WHATSOEVER TO ANY IMPLEMENTER OR THIRD PARTY FOR ANY DAMAGES OF ANY NATURE WHATSOEVER, DIRECTLY OR INDIRECTLY, ARISING FROM THE USE OF THIS SPECIFICATION.

Broadband Forum Technical Reports may be copied, downloaded, stored on a server or otherwise re-distributed in their entirety only, and may not be modified without the advance written permission of the Broadband Forum.

The text of this notice must be included in all copies of this Broadband Forum Technical Report.

Issue History

Issue Number	Approval Date	Publication Date	Issue Editor	Changes
1	21 August 2012		Daniel Cederholm Ericsson	Original
2	3 March 2014		Christopher Croot BT	Addition of information related to energy saving
2c1	1 December 2014	12 January 2015	Christopher Croot BT	Correction of Initialisation Policy text

Technical comments or questions about this Broadband Forum Technical Report should be directed to help@broadband-forum.org.

Editor	Chris Croot	BT	chris.croot@bt.com
Operations & Network Management WG Co-Chair	Peter Adams	Adtran	p.f.adams@btopenworld.com
Co-Chair	Chris Croot	BT	chris.croot@bt.com

TABLE OF CONTENTS

EXECUTIVE SUMMARY	6
1 PURPOSE AND SCOPE	7
1.1 PURPOSE	7
1.2 SCOPE	7
2 REFERENCES AND TERMINOLOGY	8
2.1 CONVENTIONS	8
2.2 REFERENCES	8
2.3 ABBREVIATIONS	9
3 TECHNICAL REPORT IMPACT	12
3.1 ENERGY EFFICIENCY	12
3.2 IPV6	12
3.3 SECURITY	12
3.4 PRIVACY	12
4 INTRODUCTION.....	13
5 DSL QUALITY IMPAIRMENTS AND INDICATORS	15
5.1 CROSSTALK NOISE.....	15
5.1.1 <i>Stationary Crosstalk</i>	16
5.1.2 <i>Short-Term Stationary Crosstalk</i>	16
5.1.3 <i>Time-varying Crosstalk</i>	17
5.2 IMPULSE NOISE	17
5.2.1 <i>Repetitive Electrical Impulse Noise (REIN)</i>	17
5.2.2 <i>Prolonged Electrical Impulse Noise (PEIN)</i>	18
5.2.3 <i>Single High level Impulse Noise Event (SHINE)</i>	19
5.3 RADIO FREQUENCY INTERFERENCE (RFI).....	19
5.4 INTRINSIC NOISE	20
6 DSL QUALITY MANAGEMENT	22
6.1 DYNAMIC SPECTRUM MANAGEMENT (DSM)	23
6.1.1 <i>Levels of coordination</i>	23
6.2 DYNAMIC LINE CODE MANAGEMENT (DLCM)	24
6.3 DSL EMBEDDED CAPABILITIES	24
6.3.1 <i>Rate Configuration</i>	25
6.3.2 <i>Margin Configuration</i>	25
6.3.3 <i>Transmit Power and Spectrum Configuration</i>	26
6.3.4 <i>Energy Efficiency for Rate, Margin, and Transmit Power</i>	26
6.3.5 <i>Channel Initialization Policies</i>	27
6.3.6 <i>Re-initialization Policy</i>	27
6.3.7 <i>Upstream Power Back-off (UPBO)</i>	28
6.3.8 <i>Downstream Power Back-off (DPBO)</i>	28
6.3.9 <i>Virtual Noise (VN)</i>	29

6.3.10	<i>SOS - Emergency Rate Adjustment</i>	31
6.3.11	<i>Seamless Rate Adaptation (SRA)</i>	33
6.3.12	<i>Impulse Noise Protection (INP)</i>	37
6.3.13	<i>Retransmission (RTX)</i>	40
6.3.14	<i>Vectoring</i>	44
6.3.15	<i>Impulse Noise Monitoring (INM)</i>	47
6.4	TEST MEASUREMENT CAPABILITIES	49
6.4.1	<i>Single Ended Line Test (SELT)</i>	49
6.4.2	<i>Dual Ended Line Test (DELT)</i>	52
6.4.3	<i>Metallic Line Test (MELT)</i>	55
6.5	EXTERNAL DQM TECHNIQUES	58
6.5.1	<i>Static Quality Management (SQM) Techniques</i>	58
6.5.2	<i>Dynamic Spectrum Management (DSM) Techniques</i>	60
6.5.3	<i>Dynamic Line Management (DLM) Techniques</i>	63
6.5.4	<i>Automatic Margin Adaptation (AMA)</i>	63
6.5.5	<i>Tiered Rate Adaption (TRA)</i>	65
7	LOW POWER STATES TECHNIQUES	67
7.1	LOW-POWER TRANSMISSION STATES TECHNIQUES	67
7.1.1	<i>Objective – basic variant</i>	67
7.1.2	<i>Target</i>	68
7.1.3	<i>Involved parameters and/or line characteristics</i>	68
7.1.4	<i>DQM Technique methods – basic variants</i>	68
7.1.5	<i>Caveats, trade-offs and limitations</i>	70
7.1.6	<i>Related DQM techniques for escalated/combined strategies on the line</i>	70
[A.1]	CONSIDERATIONS FOR ADSL2/2PLUS	72
[A.2]	CONSIDERATIONS FOR VDSL2	73

List of Figures

Figure 1:	The different paths of crosstalk	16
Figure 2:	Measurement of REIN noise	18
Figure 3:	Bit-loading from a line in the Sweden that is disturbed by AM radio	20
Figure 4:	Noise Margins	34
Figure 5:	A Reed-Solomon codeword	39
Figure 6:	Retransmission implementation schema	43
Figure 7:	Network Access Architecture supporting vectored VDSL2	45
Figure 8:	INM scheme	48
Figure 9:	DELT QLN measurement of a REIN disturber (broken power supply)	53
Figure 10:	Hlog(f) from DELT measurements of a one section line, a line with a 30 m bridged tap and a line with a 200 m bridged tap.	55
Figure 11:	MELT reference model	57
Figure 12:	Example MDF PSD mask	58
Figure 13:	Example of target noise margin (TARSNRM) profiling schemes for AMA	64
Figure 14:	Comparison of Tiered Rate-Adaptive and Rate-Adaptive profiles	66

Executive Summary

DSL Quality Management is a concept devised by the Broadband Forum to cover a range of techniques and strategies for the proactive monitoring and configuration of DSL lines to assure appropriate quality and stability for the services the lines are delivering. There are various published techniques and in-built capabilities in standardized DSL transceivers that are encompassed by DQM. These techniques and capabilities generate a rich nomenclature. Sometimes the nomenclature and techniques are used by commercial products or within the operational work-flows for access networks. As an aid to understanding DQM and the series of Broadband Forum Technical Reports in the DSL Quality Suite, TR-197 describes the published techniques and DSL capabilities and introduces the nomenclature used.

Issue 2 of TR-197 includes new material on the use and impact of energy saving techniques in the context of DQM.

1 Purpose and Scope

1.1 Purpose

The purpose of this Technical Report, TR-197, is to define a common nomenclature and a unified framework to describe functionalities, tools, techniques and strategies that are already available or under development for the support of DSL Quality Management (DQM) [14]. In building such a taxonomy of DQM “enablers” the focus is on the issues and problems to be solved rather than the implemented algorithms. Furthermore, the variants of DQM techniques that can bring energy efficiency benefits are described in conjunction with the trade-offs and constraints related to the DSL quality and stability requirements that remain a key priority for Operators. Enhancing the energy efficiency of DSL broadband access networks has become an essential part of the emerging trend towards green Information and Communication Technology (ICT). The variants of DQS techniques that can bring energy efficiency benefits are described in conjunction with the trade-offs and constraints related to the DSL quality and stability requirements that remain a key priority for Operators.

1.2 Scope

TR-197 provides a unified nomenclature for the techniques and strategies available to address DSL line stability and quality issues. TR-197 defines a common language to refer to parameters, functionalities and typical network practices in the problem domain specified above. Such an ‘alphabet’ is a fundamental prerequisite for the specification of requirements for systems enabling effective network operation strategies. Using the nomenclature TR-197 describes the in-built capabilities in DSL transceivers (defined in ITU-T Recommendations) and the published techniques that fall within the DQM concept.

This document identifies DSL configuration and diagnostic parameters and outlines the parameters to optimise data rate, stability and energy efficiency of a DSL network. Techniques and other appropriate methods are also described here along with the relationship between the three axes of quality, stability and power saving.

Pointers are given to standards defining accuracy requirements and tests for validation and verification of the DSL configuration and diagnostic parameters for DQM.

2 References and Terminology

2.1 Conventions

This Technical Report is solely informative and therefore does not contain any normative text. There are no conventions relating to requirements. Normative text is confined to component documents of the DSL Quality Suite.

2.2 References

The following references constitute provisions of this Technical Report. At the time of publication, the editions indicated were valid. All references are subject to revision; users of this Technical Report are therefore encouraged to investigate the possibility of applying the most recent edition of the references listed below.

A list of currently valid Broadband Forum Technical Reports is published at <http://www.broadband-forum.org>.

Document	Title	Source	Year
[1] RFC 2119	<i>Key words for use in RFCs to Indicate Requirement Levels</i>	IETF	1997
[2] RFC 2233	<i>The Interfaces Group MIB using SMIV2</i>	IETF	1997
[3] G.992.3	<i>Asymmetric digital subscriber line transceivers 2 (ADSL2)</i>	ITU-T	2009
[4] G.992.5	<i>Asymmetric Digital Subscriber Line (ADSL) transceivers – Extended bandwidth ADSL2 (ADSL2plus)</i>	ITU-T	2009
[5] G.993.2	<i>Very high speed digital subscriber line transceivers 2 (VDSL2)</i>	ITU-T	2006
[6] G.993.5	<i>Self-FEXT cancellation (vectoring) for use with VDSL2 transceivers</i>	ITU-T	2010
[7] G.996.2	<i>Single-ended line testing for digital subscriber line (DSL)</i>	ITU-T	2009
[8] G.997.1	<i>Physical layer management for digital subscriber line (DSL) transceivers</i>	ITU-T	1996
[9] G.998.4	<i>Improved impulse noise protection for DSL transceivers</i>	ITU-T	2010
[10] TR-100	<i>ADSL2/ADSL2plus Performance Test Plan</i>	BBF	2007
[11] TR-114	<i>VDSL2 Performance Test Plan</i>	BBF	2009
[12] TR-126	<i>Triple Play Services Quality of Experience Requirements</i>	BBF	2006

[13]	TR-176	<i>ADSL2Plus Configuration Parameters for IPTV</i>	BBF	2008
[14]	TR-188	<i>DSL Quality Suite</i>	BBF	2010
[15]	TR-198	<i>DQS: DQM systems functional architecture and requirements</i>	BBF	2010
[16]	TR-202	<i>ADSL2/ADSL2plus Low-Power Mode Guidelines</i>	BBF	2010
[17]	MR-204	<i>Energy Efficiency, Dematerialization and the Role of the Broadband Forum</i>	BBF	2009
[18]	Deliverable TF2.2	<i>Position paper on Dynamic Spectrum Management (DSM) and Dynamic Line-Code Management (DLCM)</i>	IST-MUSE project	2005
[19]	Deliverable B2.1	<i>Static and Dynamic Spectral Management Analysis - Issue 2</i>	IST-MUSE project	2006
[20]	Deliverable B2.3	<i>Migration guidelines for DSL from operator's view</i>	IST-MUSE project	2005
[21]	ATIS-PP- 0600007	<i>Dynamic Spectrum Management</i>	ATIS- COAST	2007
[22]	NICC ND 1513	<i>Report on Dynamic Spectrum Management (DSM) Methods in the UK Access Network</i>	NICC	2010
[23]	ANSI T1.417	<i>Spectrum Management For Loop Transmission Systems, American National Standard For Telecommunications</i>	ANSI	2003
[24]	NICC ND 1602	<i>Specification of the Access Network Frequency Plan applicable to transmission systems connected to the BT Access Network</i>	NICC	2011
[25]	ATIS- 0600027	<i>Guidance for the Use of Upstream Power Back Off Parameters for ITU-T Recommendation G.993.2 Annex A, Issue 2</i>	ATIS- COAST	2010

2.3 Abbreviations

This Technical Report uses the following abbreviations:

ADSL	Asymmetric Digital Subscriber Line
AM	Amplitude Modulation
AN	Access Node
CO	Central Office
CPE	Customer Premises Equipment
DELT	Dual Ended Line Test
DLCM	Dynamic Line Code Management

DLM	Dynamic Line Management
DMT	Discrete Multi-Tone
DQM	DSL Quality Management
DQS	DSL Quality Suite
DSL	Digital Subscriber Line
DSM	Dynamic Spectrum Management
FDM	Frequency Division Multiplexing
FEC	Forward Error Correction
FEXT	Far End Crosstalk
HAM	Amateur radio
HDSL	High bit rate Digital Subscriber Line
HDTV	High Definition Television
IAT	Inter Arrival Time
INP	Impulse Noise Protection
INPEQ	Impulse Noise Protection Equivalent
IPTV	Internet Protocol Television
LOM	Loss Of Margin
LW	Long wave
MELT	Metallic Line Test
MW	Medium wave
NEXT	Near End Crosstalk
OSS	Operations Support System
PEIN	Prolonged Electrical Impulse Noise
PSD	Power Spectral Density
QoE	Quality of Experience
QoS	Quality of Service
REIN	Repetitive Electrical Impulse Noise
RFI	Radio Frequency Interference
SDTV	Standard Definition Television
SELT	Single Ended Line Test
SHDSL	Symmetric High-speed Digital Subscriber Line
SHINE	Single High-level Impulse Noise
SNR	Signal-to-Noise Ratio
SNRM	Signal-to-Noise Ratio Margin
SRA	Seamless Rate Adaptation
SSM	Static Spectrum Management

SW	Short wave
TDD	Time Division Duplexing
TDMA	Time Division Multiple Access
VDSL	Very high-rate Digital Subscriber Line
VN	Virtual Noise

3 Technical Report Impact

3.1 Energy Efficiency

The scope of TR-197 covers improvements in energy efficiency.

3.2 IPV6

TR-197 has no impact on IPv6.

3.3 Security

TR-197 has no impact on security.

3.4 Privacy

TR-197 has no impact on privacy.

4 Introduction

DSL Quality Management (DQM), per its definition in TR-188 “*DSL Quality Suite*” [14], aims to improve the stability, quality and performance of DSL lines. An additional benefit with respect to these objectives is the ability to improve energy efficiency. Generally speaking, this is achieved by means of “DSL line management techniques” that will be referred to as **DQM techniques** in the remainder of this document. A DQM technique modifies (groups of) parameters to achieve certain effects on the line.

The essence of a DQM technique is its **method**, i.e. the concatenation of processes “data collection – analysis/diagnosis – changes on the line(s)” to achieve the goal(s) of the technique (e.g. stability increase, quality improvement, service/performance upgrade, etc.). Hence, implicitly a DQM technique is associated with monitoring the line itself and - depending on each case - it is typically focused on specific parameters associated to the nature of the technique.

Typically DQM technique categories focus on a given stability/performance “area” of DSL transmission strictly influenced by a group of parameters configured in the line profile. In other words the usual objective of finding the appropriate trade-off between reducing noise influence and maintaining good bitrates leads to the “tuning” of the DSL line code or the signal spectrum. This introduces two main categories of DQM techniques: Dynamic Line Code Management (DLCM) and Dynamic Spectrum Management (DSM). New transceiver functionalities such as Virtual Noise and Retransmission may be exploited to build up new techniques and in certain cases the combined use of basic techniques leads to structured ones that better fit troublesome line conditions experienced in real networks. Furthermore line testing techniques such as SELT, DELT and MELT can be utilized to further enhance troubleshooting capabilities and they can also be used to trigger other DQM methods.

Enhancing the energy efficiency of DSL broadband access networks has become increasingly important as part of the emerging trend towards green Information and Communication Technology (ICT). DQM techniques may help improve energy efficiency. Many DSL lines transmit excessive power and are often underutilized. There is a fundamental trade-off between performance, stability, and energy usage. In general, improving one of these three axes means that at least one of the others may degrade, although this degradation could be imperceptible in some cases. A DQM system can manage multiple DSL lines to manage the trade-offs between these parameters. Reducing power appropriately on a given line may not decrease the data rate or line stability (depending on the service rate and performance specification) of that line, and it may sometimes even result in increased data rates or stability for neighbouring lines due to crosstalk reduction.

This Technical Report develops a categorization and description of the building blocks of DQM techniques and provides guidance for their use in a stand-alone or combined manner. This is done coherently with the architectural specification of DQM systems provided in TR-198 [15].

This Technical Report provides a taxonomy of DQM techniques. It is solely informative and contains no normative requirements or recommendations regarding the advisability of use of any

particular technique. Furthermore, specification of the design, implementation or performance capabilities of any DQM algorithm or technique is outside the scope of this Technical Report.

5 DSL Quality Impairments and Indicators

5.1 Crosstalk Noise

Crosstalk is one of the major limiting factors on the performance of DSL systems if proper management and/or mitigation techniques are not used. It occurs when the electromagnetic coupling between different transmission lines causes interference between the signals. In simple words this means that the signal from one line is “leaking” into a second line where it is seen as noise and thus decreases the SNR of the transmission on that line.

Twisted pairs are typically grouped into cable binders. Within a binder the lines are located very close to each other and the closer they are the higher the coupling and thus the crosstalk will be. The effect of crosstalk can however be decreased by using different twist lengths on different pairs to reduce the symmetry and thereby reducing the coupling between them. Different binders can also be twisted around each other so that no two binders are adjacent for long runs, to minimize the crosstalk. The twisting is however not perfectly random and a line is typically adjacent to some of the lines in the cable for longer distances than to some other lines in the same cable. Also, the conductors are not perfectly identical and so there is at least some small capacitive unbalance between pairs. This means that typically one line in a cable may experience more crosstalk than other lines in the same cable. The level of crosstalk is hence highly dependent on the type and quality of the cable and it will vary from pair to pair and with frequency.

There are two different types of crosstalk, Near End crosstalk (NEXT) and Far End crosstalk (FEXT). NEXT is the crosstalk from a transmitter to a receiver that is located in the same end of a transmission line. This can cause a severe impairment since the signal sent from the remote transmitter has been attenuated along the transmission line before reaching the local receiver while the leaking signal just was sent out from another local transmitter and thus has not been attenuated as much. FEXT is the crosstalk leaking into another transceiver on the opposite end of the subscriber loop. This means that the induced crosstalk has to travel along the line and both the signal and the crosstalk will be attenuated by the loop. The different paths of the NEXT and the FEXT crosstalk are shown in Figure 1.

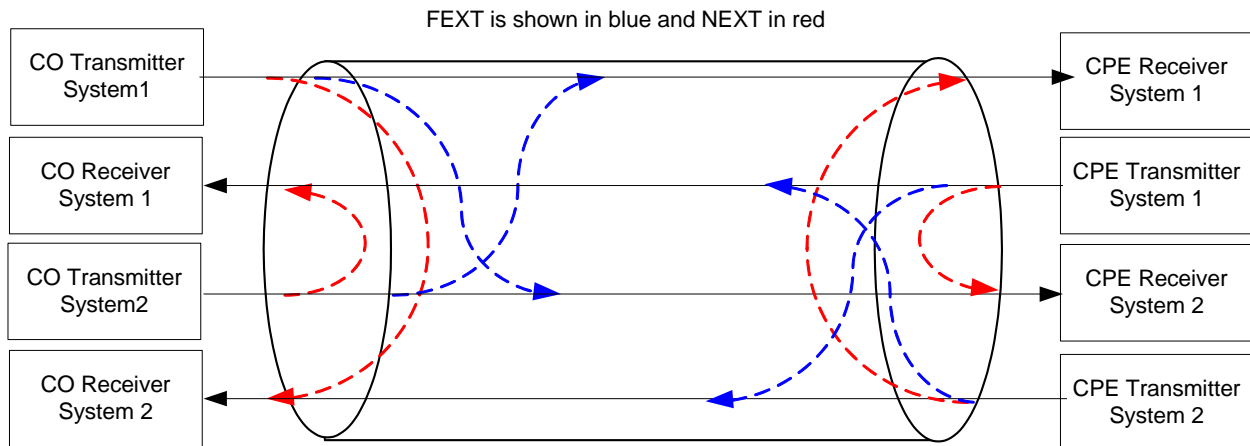

Figure 1: The different paths of crosstalk

In some deployment scenarios the twisted pairs inside a cable binder are used for different types of DSL services. The crosstalk disturber can therefore originate from transmission lines running any kind of DSL service e.g. HDSL, SHDSL, ADSL or VDSL. The crosstalk that originates from a signal of the same service as the disturbed signal is often referred to as self crosstalk while crosstalk between different types of services are called foreign or alien crosstalk. Self NEXT can be avoided by using a frequency division multiplexed (FDM) system where different frequency bands are used for upstream and downstream tones. By avoiding overlapping frequency bands there is no NEXT in the receive bands and thus no impact on SNR. This technique is for example commonly used in ADSL/ADSL2/ADSL2plus and VDSL2. This way of avoiding NEXT is however not possible for alien crosstalk since different kinds of services uses different bandwidth and the spectra of many types of services overlap.

5.1.1 Stationary Crosstalk

If the transmission system conditions for a line are constant and the number of disturbers is fixed, then the crosstalk seen by that line will also stay constant. This is called stationary crosstalk. Stationary crosstalk will decrease the SNR and thus the performance of DSL if it is not mitigated properly. It will then also limit the reach of a service requiring a specific bit rate. However, stationary crosstalk does not decrease the DSL stability.

5.1.2 Short-Term Stationary Crosstalk

Some types of DSL transmitters operate in transmission modes in which an “ON” condition (in which the transmitter generates a signal) alternates with an “OFF” condition (in which the transmitter is silent or generates only a pilot tone). Examples of such transmitters include TDD or TDMA systems, and burst transmission systems that use quiescent modes to reduce power consumption during idle data periods. Such transmitters are referred to as “short-term stationary” [23], since during the “ON” condition the transmitted signal has the same effect as a stationary signal when observed over an appropriately short time interval.

A DSL transceiver may initialize when a short-term stationary crosstalk source is “OFF,” and subsequently operate when the short-term stationary crosstalk source is “ON” during which time

there can be a high error rate. It is common practice to isolate short-term stationary systems from typical stationary DSLs; either by using different cables or binders, or by using different frequency bands.

5.1.3 Time-varying Crosstalk

If the power level of crosstalk is changing over time it is referred to as time-varying crosstalk. This can e.g. be caused by users turning of their CPEs and thus changing the number of disturbers, or that the channel conditions such as the crosstalk transfer functions are changing because of external effects such as e.g. water ingress in cables or temperature changes.

Since this type of crosstalk is varying over time the SNR for that line will vary as well. It is then necessary for the transmission system to take precaution for these SNR changes or act dynamically to adapt to the changing noise conditions. Otherwise the stability of the line will decrease and defects like Loss Of Margin (LOM) can cause retrains and service interruption. Also, net data rate can decrease.

5.2 Impulse Noise

Impulse noise consists of bursts of energy which typically are limited in time, have high amplitude and broad frequency spectra. It is commonly caused by electromagnetic radiation that can origin from a wide range of sources such as power lines, lightning strikes, switches, power supplies and fluorescent lighting. Because of the diversity of noise sources there are many different types of impulse noise with a wide range of characteristics. It can for example appear both repetitively with a constant frequency as well as non-stationary bursts with random amplitude. Since a modern household often contains many electrical devices that might radiate electromagnetic signals, impulse noise is usually injected at the CPE side of the copper loop.

The fact that the occurrence of noise bursts is relatively sparse means that the received average SNR is not significantly affected by impulse noise and thus the received bit rate is not reduced by much. However, the high amplitude and bursty nature of impulse noise can still be a major impairment for DSL transmission since it causes a significant and rapidly varying SNR variation. Without proper protection a sudden noise peak will typically corrupt one or several consecutive DMT symbols leading to severe service degradation such as e.g. IPTV pixelizations. It is therefore important to use mitigation techniques such as coding and interleaving and/or retransmission on lines affected by impulse noise.

5.2.1 Repetitive Electrical Impulse Noise (REIN)

Noise bursts that reoccur with a fixed inter-arrival time is commonly called REIN. It can be caused by badly shielded household devices, light dimmers and switching power supplies. Since it originates from electrical devices powered from the power network it typically has a repetition frequency of twice the main power distribution frequency i.e. 100 Hz in Europe and 120 Hz in North America. Figure 2 shows a measured REIN from a European network. As can be seen the noise consists of repeating bursts with an inter-arrival time of 10 ms (100 Hz).

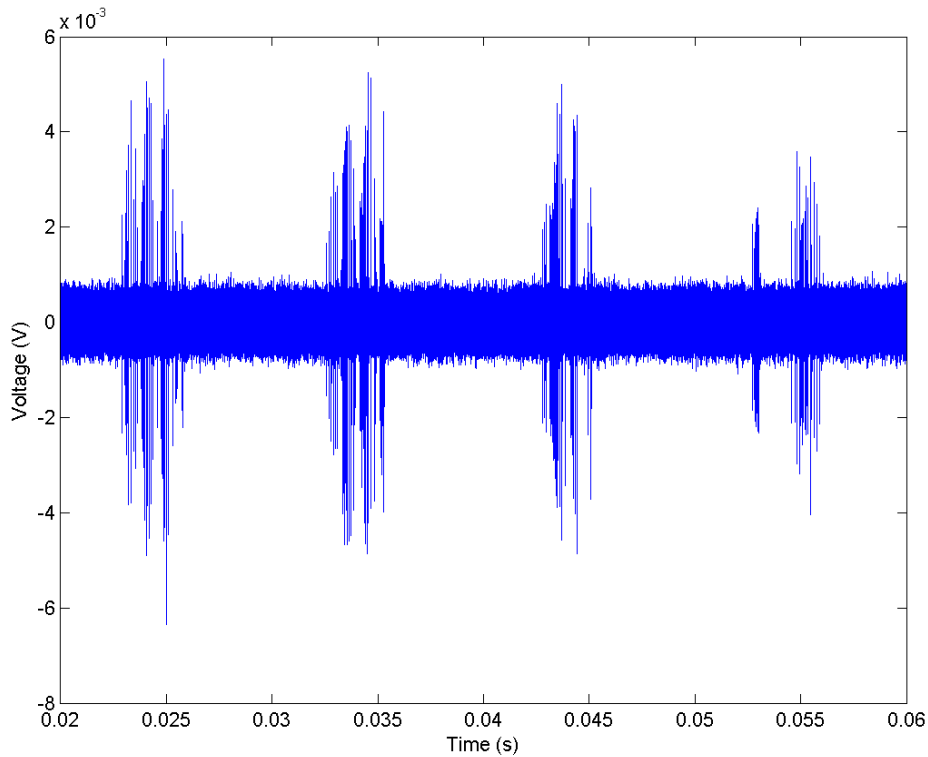

Figure 2: Measurement of REIN noise

The noise burst lengths are typically rather short, around $100\ \mu\text{s}$, which means that each noise burst can corrupt one or two consecutive DMT symbols. However, since the bursts repeat quite frequently, unless mitigation techniques are used there will be a lot of bit errors over time. Also, the repetitive behaviour will make traditional coding and interleaving inefficient if the interleaver depth is greater than the inter-arrival time of the impulses since errored bits from several bursts then might be spread to the same DMT symbol. Retransmission might also be inefficient if the data transmission units are retransmitted with the same frequency as the REIN repetition frequency and special REIN parameters are therefore defined in G.998.4 [9] to avoid this.

5.2.2 Prolonged Electrical Impulse Noise (PEIN)

PEIN is defined as noise bursts with a burst length between 1 ms and 10 ms and with random amplitude and inter-arrival times. In a series of measurements made by a major European operator it was found that the median PEIN inter-arrival time in the collected data was 61 s and the average inter-arrival was 193s.

Bit errors caused by short PEIN might be avoided by the use of traditional coding and interleaving. Typically very high amounts of overhead and delay is needed which would drastically reduce the transmission performance. Other techniques like e.g. retransmission might be more efficient to combat this type of noise.

5.2.3 Single High level Impulse Noise Event (SHINE)

Noise bursts even longer than PEIN, i.e. > 10 ms, is referred to as SHINE. These impulses are typically too long to be mitigated by both coding and interleaving and retransmission. Commonly used performance requirements, e.g. those specified in Broadband Forum Technical Reports TR-100 [10] and TR-114 [11], therefore do not expect error free transmission for a DSL system impaired by SHINE. It is however required that under these tests the line should not retrain because of the noise bursts.

5.3 Radio Frequency Interference (RFI)

Another type of noise that might degrade DSL transmission is Radio Frequency Interference. As for impulse noise this can originate from a wide range of sources such as badly shielded electrical devices and wireless transmission signals such as AM radio broadcasts and amateur radio transmissions (HAM). DSL lines, especially drop and inside wire, are susceptible to external electromagnetic interference which will induce a signal with respect to ground into the line. Since DSL uses differential mode transmission this will not be a problem if the twisted pair is perfectly balanced. However, in practice no such perfect line exists and bad quality cables may have poor balance making them receptive to RFI. There are many types of metallic faults that can degrade balance, e.g. corroded joints (that affect one wire more than the other), one wire cuts and leakage to ground. Poor in-home wiring such as where untwisted pairs are used is also a common cause of degraded balance. A centralized splitter might help to reduce the effect of the in-home wiring. Because aerial cables are more common closer to the customer (e.g. drop wires) and due to the effect of poor in-home wiring, more RFI is often received at the CPE side than the CO side of the loop.

Radio signals are quite narrowband (kHz) compared with the DSL spectra and the transmission frequencies are limited to bands defined by regulations. Long Wave (LW) AM radio is broadcasted on 148.5 – 283.5 kHz (9 kHz channel spacing), Medium Wave (MW) on 520 – 1610 kHz (9 or 10 kHz channel spacing) and Short Wave (SW) on 2.3 – 26.1 MHz (5 kHz channel spacing). The main carrier of an AM signal is typically stable in both amplitude and frequency but the sidebands can vary rapidly. A DSL line disturbed by AM radio will experience dips in the bit loading at the frequencies of the broadcast stations. Since the main AM carrier is stable this will mostly decrease the achievable bit rate of DSL, but there is a risk that the fluctuating sidebands also will cause packet loss if not handled correctly. The bit loading of several carriers beyond those with RFI energy are often affected due to the sinc roll-off of DSL receivers.

Figure 3 shows the bit-loading from a line in Sweden that is disturbed by AM radio ingress. Some dips in the bit-loading can be mapped to the broadcast frequency of different radio stations.

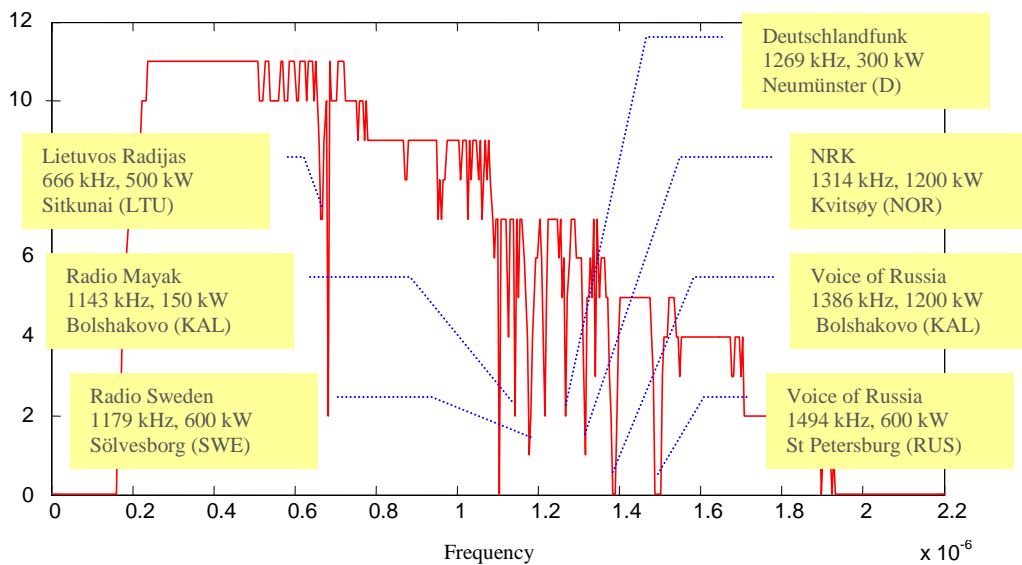

Figure 3: Bit-loading from a line in the Sweden that is disturbed by AM radio

RFI from an AM radio station far away from the line typically varies over the time of day, and if the disturbed line is monitored over several days a diurnal pattern can often be seen. This is caused by the level of ionization in the ionosphere that is dependent on the sun. During the night the electron density in the ionosphere will decrease and then radio signals will be refracted and start traveling skywave instead of groundwave. AM radio therefore has much longer reach after sunset and the noise received on DSL lines are hence worse during “dark” hours. In some countries this effect is somewhat compensated for by regulations that require reduced broadcasting power after sunset, but in other countries no regulations at all are used. Another reason for diurnal patterns is that some broadcast stations only transmit at a certain time of the day (typically in the evening).

During the time the ionosphere is changing its physical properties (mostly during sunset and sunrise) there can be large variations in the level of noise received by a DSL line. These variations can be quite rapid causing both rate loss and instability problems for the DSL transmission. The effect of varying RFI is sometimes referred to as fading RFI.

The allowed transmission frequencies for amateur radio (HAM) are limited to a number of small bands between 1.81 MHz and 29.7 MHz. Noise ingress from HAM is thus mainly an issue for VDSL2. HAM noise is typically less stationary than AM radio noise since a signal is only transmitted when a message is being sent. The signals might also change carrier frequency occasionally. These characteristics and the fact that amateur radio often transmits with a relatively high power from a location close to the CPE side of DSL lines, makes HAM a risk for the stability of DSL.

5.4 Intrinsic Noise

Thermal noise and other types of intrinsic noise from components in the DSLAM and CPE are often considered to be part of the background noise seen by the DSL system. Spectral leakage e.g. leakage from one transmission direction into the opposite direction is another source of

intrinsic noise. Such types of noise typically have relatively low power (-130 dBm/Hz or lower) and are almost negligible for a crosstalk limited system. However, for a vectoring system that manages to cancel all the crosstalk and has no other external noise ingress, intrinsic noise can be one of the factors that limit the bit rate.

6 DSL Quality Management

DQM techniques can enable improvements in DSL stability, performance and data rate or reach. Static configurations set a line profile with parameters that seek to achieve a good compromise between data rates and stability/performance. In setting the parameters assumptions are made about the expected channel characteristics and levels of noise. The problem with static configuration is that the noise environment and, to a lesser extent the metallic pair characteristics, can change with time. Unless conservative static configuration parameters are used the performance may deteriorate or the line may become unstable.

In DQM the test, performance and status parameters available from DSL modems are collected. These parameters, along with other data, are analysed and then new configuration parameters determined that either increase data rate and/or improve performance or stability.

The main categories of configuration parameters that determine the achieved performance and influence line quality and stability on a given line are:

- Data Rate
- Transmit Power Spectral Density (PSD)
- Spectral Masking
- Signal-to Noise Ratio Margin (SNRM)
- Impulse Noise Protection (INP)
- Virtual Noise (VN)
- Re-initialization Policy

In each category there are several parameters, see G.997.1 [8].

All DSL modems have a channel initialization policy which determines how the line signal is constructed to meet the configuration parameters. The modem's own channel and continuous noise measurement capabilities determine the number of bits that could be used on each DMT carrier to meet the constraints set by the configuration parameters. The line code structure, bit loadings and transmit PSD are then determined according to the channel initialization policy. DQM techniques make use of this inherent capability of DMT based DSLs by assisting the network operator in applying optimum values to the configuration parameters that control these initialization policies.

Seamless Rate Adaptation and SOS are standardized capabilities implemented in some DSL modems which adjust the transmission rate in order to adapt to changes in noise during operation of the modem. These can be considered as DQM tools.

Vectoring (as defined in G.993.5 [6]) and retransmission (as defined in G.998.4 [9]) are recently defined techniques for amelioration of the effects of crosstalk and noise.

This rich functionality in DSL modems can be used in Static Quality Management or in various ways by dynamic systems that focus on different aspects of the functionality. The main types of dynamic techniques described in the literature [18], [19], [20], [21] are:

- Dynamic Spectrum Management (DSM)
- Dynamic Line Code Management (DLCM)

The techniques try to optimize the performance of DSL to meet an overall mix of service objectives.

DSM techniques adjust the transmitted signal power and frequency bandwidth used, to minimize the impact of crosstalk noise between the DSLs sharing the cable allowing balancing of the trade-off between performance and quality/stability. These techniques mainly deal with data rate, SNRM and PSD configuration as well as the use and configuration of vectored systems.

DLCM techniques optimize the line-code to achieve the best performance possible without negatively impacting other systems sharing the cable plant. DLCM techniques mainly use the INPMIN and Maximum Delay parameters to improve the quality and stability, primarily against impulse noise but also help against other noise types (e.g. crosstalk and RFI).

6.1 Dynamic Spectrum Management (DSM)

The goal of DSM is to improve DSL performance by limiting crosstalk among the different DSL lines in a cable/binder. It can achieve this by reducing transmit power to the minimum required in order to achieve target bit rates with specific margins and guaranteed quality of service. DSM techniques also optimize performance by appropriate configuration of other performance parameters to ensure optimum stability and rate/reach. DSM rules suggest situation-dependent (i.e. adaptive or dynamic) configuration of signals, spectra, and operation of DSL modems that are found spectrally compliant.

6.1.1 Levels of coordination

Existing DSM descriptions state four levels of coordination, including the whole range starting from DSL implementing Static Spectrum Management (no coordination) and progresses to full coordination of all the DSL systems in the cable/binder.

Notice, that a single binder may include a combination of systems using any or all levels of coordination over the individual lines, depending upon the service-provider's preferences and practice in the region. A DSM-compliant DSL modem may indicate its capability to release channel information at Levels 1, 2, or 3 of coordination.

6.1.1.1 Static Spectrum Management (SSM)

In Static Spectrum Management the transmit spectrum of any deployed system is strictly limited to be below the predefined value (usually characterized by the PSD mask), which is fixed by regulations. SSM doesn't take advantage of specific conditions of the particular deployment, such as loop length, type of other system operating in the cable, delivered service type etc.

In SSM, none of the performance, test and status data that is available from the DSL modem is used. The DSL system operates autonomously under specified static deployment guidelines only.

6.1.1.2 Dynamic Spectrum Management Level 1 (DSM L1)

DSM Level 1 requires data collection of at least data rates, transmit power, and SNR margin, and some line information to the Analysis & Diagnosis Function (ADF). Systems providing DSM Level 1 functionality may also perform DLCM on a DSL line as well as enhancements specifically related to management of the line's PSD.

6.1.1.3 Dynamic Spectrum Management Level 2 (DSM L2)

More data information, in particular full information on transmit PSD, may be obtained from the modems for use by DSM Level 2 techniques. These techniques imply that spectra of DSL modems, in addition to the data rates of DSL systems, may be controlled. Since DSM Level 2 also considers systems operated by the same provider on adjacent cable pairs, Level 2 coordination will increase the performance due to the lowering of crosstalk noise.

6.1.1.4 Dynamic Spectrum Management Level 3 (DSM L3)

DSM Level 3 involves real time data collection and control and is essentially the same as Vectoring (See Section 6.3.14). There are both management configuration and monitoring parameters specific to the management of Vectoring. These parameters can be used for diagnostics and also to enable vectoring on particular lines as well as controlling the frequency bands / vector groups etc. DSM Level 3 coordination allows downstream transmitted signals of this group to be generated jointly and also upstream received signals to be processed jointly. This makes it possible to cancel crosstalk noise coming from adjacent pairs by the use of vectoring.

The use of DSM for DSL energy efficiency is discussed in sections 6.5.2.7 and 6.5.2.8 of this document.

6.2 Dynamic Line Code Management (DLCM)

DLCM techniques aim at improving DSL quality/stability by permitting line coding parameters to be modified in response to the prevailing conditions of the particular deployment, thereby adapting the configuration of a given DSL system to improve its performance capability.

The purpose of DLCM is to dynamically change line coding configurations to enhance reliability and data rates of DSL systems in the presence of impulse and crosstalk noise. DLCM is intended to operate by taking into account parameters of both the loop plant environment and DSL transmission system that are time and deployment dependent. The first stage of DLCM operation is to diagnose the prevailing noise environment in order to differentiate between crosstalk, RFI, isolated or repetitive impulsive interference and simple changes of line characteristic. The DSL line coding configuration parameters currently considered to be adjusted are the Minimum INP and Maximum Interleaving Delay parameters which lead to the modems adjusting forward error correction (FEC) settings and the interleaving depth.

DLCM may be largely autonomous, under network management supervision, or involve detailed intervention on a per-line basis. A key issue is the need to deliver network-wide service stability and per-line service reliability, despite varying noise conditions arising from the dynamic nature of line parameters.

6.3 DSL Embedded Capabilities

In this section various features that are embedded in the DSL modems and determine the capability of a DSL connection to deliver data at a particular rate and quality are described. DSL modems. These features are either parameters or functionalities that may be statically set or used by an external DQM system that changes their configured values in order to improve quality. The first seven sub-sections (6.3.1 - 6.3.4) describe configuration parameters that can be set via the DSL management entity and the others are autonomous processes that can be selected in the modems but that have some controlling parameters that determine their behaviour.

6.3.1 Rate Configuration

The upstream and downstream rates that a modem pair will achieve on initialization are controlled by maximum and minimum data rate parameters for each channel and the initialization mode. In one mode the minimum data rate fixes the actual data rate, in another the modems set their data rates between the minimum and maximum data rates. These parameters are set before the modems initialize and then the modems train up to maximize the net data rate up to the maximum data rate parameter. How the excess data rate above the minimum data rate is apportioned when there is more than one channel is controlled by the rate adaptation ratio. If a pair of modems is experiencing poor transmission quality then, provided the required service data rate is still delivered (by keeping the minimum data rate parameter constant), then the maximum data rate parameter can be reduced for improving the transmission quality. In some cases lowering the bit rate results in increased SNR margin and in this case a direct improvement in noise tolerance may be obtained. If the system is already operating at its maximum margin, then the power is reduced and the required improvement in SNR margin is not achieved. Hence the stability of the line will not improve but the stability of neighbouring lines may improve since the crosstalk may be reduced. A DQM technique that uses control of data rate parameters to improve quality, called Tiered Rate Adaptation, is described in Section 6.5.5.

6.3.2 Margin Configuration

There are three signal-to-noise ratio margin (SNRM) parameters for each direction of transmission: target, maximum and minimum. A SNRM is the margin above the SNR that is required to achieve the target BER of all the DSL bearer channels. As explained in Section 6.3.4 the modems initialize to achieve at least the target margin. If the noise conditions change then modems will do one of two things. If the noise increases to the extent that the minimum SNRM is no longer achieved it is possible for the OLR mechanism to change the power levels per carrier by requesting an increase to the gain scaling values thus increasing the SNR margin. If this is not possible because power is at the maximum permitted then a Loss of Margin defect occurs and a re-initialization is attempted and the management system informed. If the margin increases so that the maximum margin is exceeded then transmit power is reduced.

The quality of transmission in the presence of continuous noise is directly affected by the SNRM values that are set. A greater tolerance to noise will be achieved by increasing the SNRM values. The modems train up as described above and the signal configuration that achieves the actual SNRM remains constant after initialization (unless SRA is used, see Section 6.3.11) and so an increase in noise after initialization will more readily be tolerated if higher values of SNRM are used. However, the use of higher values of SNRM can lead to increased power usage and hence increase crosstalk in neighbouring line so should only be used where the DSL environment renders it necessary.

TR-176 [13] discusses the choice of SNRM values for supporting IPTV services over DSL. A DQM technique, called Automatic Margin Adaptation, which adjusts SNR margin parameters to improve quality, is described in Section 6.5.4.

6.3.3 Transmit Power and Spectrum Configuration

There are various parameters specified in the DSL Recommendations that control the overall power transmitted to line by DSL modems and the Power Spectral Density of transmitted signals. In general terms the higher the transmit power the greater the tolerance to noise there can be to a particular level of noise. However, there are limits to the power that can be transmitted because of the crosstalk interference into adjacent lines and electromagnetic radiation. The shaping of PSDs to prevent undue crosstalk may be desirable on any line. The control of PSDs is of particular use in some forms of DSM as described in Section 6.5.2. One particular control that is useful in static configuration of PSDs is the use of parameters that prevent the use of specific carriers in the DMT signal. If there is a strong known interference source at a particular frequency, e.g. from a radio station, then avoiding that frequency means that power is not wasted on a carrier that will not be able to carry data with an acceptable error rate.

It is also possible to save power by spectral optimization. For example, lower frequencies have less attenuation and so a lower transmit power can be used to get the same received power as at higher frequencies. So, the total transmit power may be lowered if a line transmits more power at lower frequencies with low attenuation, and less power at high frequencies with high attenuation.

6.3.4 Energy Efficiency for Rate, Margin, and Transmit Power

DSL lines can operate at unnecessarily high power and margin levels. DQM techniques can be used to configure a line to optimize power usage, by lowering transmit power to limit excess margin where possible.

DQM systems can implement algorithms to configure a line to reduce transmitted power by actions such as tuning SNRM parameters on appropriate lines without degrading line stability. To ensure service stability or data rate while lowering the power levels, DSL line profile settings should be re-optimized and the performance of the DSL lines should be measured and verified after a SNRM reduction. Lines that are measured to significantly lose performance with lower power levels should not reduce their margin. Considerations about the relationship between transmit power reduction and the overall equipment consumption are reported in Appendix A - Transmit power savings relation to overall energy savings.

Along with the trade-off among the axis mentioned above, it should be noted that the actual measurement of the power consumption at the power mains of DSL equipment (DSLAMs, MSANs, ONUs, CPEs, Residential Gateways) is typically not available. Although the overall power consumption is intuitively related with the transmit power over the DSL line(s), just like other power parameters of the functional blocks of the equipment, the exact relationship between the two varies considerably from product to product and depends on the operational conditions.

Field and lab measurements have proven [A.11] that appropriate management of the transmit power on the DSLs can produce measurable savings on the mains power usage in the DSLAM

without reducing service quality. Field testing has also shown [A.11] that reducing DSLAM power can result in higher downstream rates in the network due to reduced crosstalk. Therefore, techniques for reducing transmit power are of value in potentially saving energy in a DSLAM and increasing data rates, even if there is no attempt to directly measure and manage the overall DSLAM power usage .

6.3.5 Channel Initialization Policies

In the ITU-T Recommendations for ADSL2/2plus and VDSL2 there are three channel initialization policies specified: a mandatory Policy ZERO and optional Policy ONE and Policy TWO. For all the policies initialization involves ensuring that:

- Message overhead data rate \geq Minimum message overhead data rate;
- Net data rate \geq Minimum net data rate for all bearer channels;
- Impulse noise protection \geq Minimum impulse noise protection for all bearer channels;
- Delay \leq Maximum delay for all bearer channels;
- SNR Margin \geq Target SNR margin.

In Policy ZERO initialization first of all the net data rate for all bearer channels is maximized and then if there is any margin capability left the transmit power is reduced to minimize the excess margin with respect to the specified maximum noise margin. This policy delivers the maximum possible data rate and at least the target SNR margin against the noise present at initialization for the lowest possible transmit power. Thus the crosstalk into other lines is minimized.

In Policy ONE initialization the actual value of INP is maximized for the bearer channel once the maximum data rates are achieved. The intent with this policy is to use the maximum redundancy in the FEC that the modem can deliver to get the best protection against impulse noise.

In Policy TWO initialization first of all the net data rate for all bearer channels is maximized up to the specified maximum data rates. Then, if such maximized net data rate is equal to the maximum net data rate for a bearer channel, the SNR margin for that bearer channel is maximized up to a specified maximum SNR margin. If there is any margin capability left the transmit power is reduced to minimize the excess margin with respect to the maximum noise margin. This policy delivers the specified maximum data rate and the maximum SNR margin against the noise present at initialization for the lowest possible transmit power. Thus the highest possible margin against crosstalk is obtained for a fixed rate.

The policy used is selected by the management system.

The selection of the channel initialization policy, and the maximum noise margin used by the channel initialization policy, can affect energy efficiency by changing the transmit power.

6.3.6 Re-initialization Policy

G.993.2 [5] and G.997.1 [8] define an optional VDSL2 re-initialization policy for VDSL2 (RIpolicy = 1) where a MIB parameter (REINIT_TIME_THRESHOLD) specifies the number of contiguous severely errored seconds (SES) which must occur before triggering a re-initialization.

This may be useful for improving VDSL2 stability for lines which would have otherwise re-initialized too often. A re-initialization typically results in a loss of service for about 60 seconds while the modem re-establishes synchronization and re-trains to the line characteristics.

6.3.7 Upstream Power Back-off (UPBO)

Upstream VDSL2 signals often come from CPE that are at different distances from a DSLAM. If all upstream transmissions were to transmit at the same PSD and power level, then the long lines could experience high-power FEXT from the short lines. Upstream Power Back-Off (UPBO) is employed to make this situation more equitable. Lowering the transmit power of the closer CPE lowers the FEXT they generate into longer lines.

UPBO is based on the electrical length of the line, kl_0 , a measure of the attenuation of the signal caused by the copper loop. As kl_0 increases, the allowed transmit signal levels increase, up to the limit PSD mask. The kl_0 parameter can be estimated internally by the DSL modem, or controlled directly by setting the parameter value via a management interface, and kl_0 can have different values in each different upstream frequency band. Levels of UPBO can also be controlled in the CO-MIB by setting parameters “a” and “b”, which can be chosen separately for each different upstream frequency band. An overview of the use of “a” and “b” is provided in ATIS-0600027 [25].

A side effect of UPBO is improved energy efficiency by decreasing transmit power (see Appendix A).

6.3.8 Downstream Power Back-off (DPBO)

Downstream Power Back-Off (DPBO) is defined in ITU-T Recommendations for ADSL2 [3], ADSL2plus [4], and VDSL2 [5]. The objective of DPBO is to reduce the downstream power injected by DSL at a remote terminal or cabinet to approximately the same as if the signal was injected at the CO or exchange. The degree of DPBO varies automatically as a function of the electrical length of the cable (E-side length) from the CO or exchange to the remote terminal or cabinet.

The resulting PSD mask for the cabinet based transmitters is a function of a number of parameters that can be set through a management interface, including PSD mask limits, the E-side length, minimum usable PSD mask, lower and upper frequencies at which DPBO applies. The loop insertion loss, used to shape the frequencies of interest, is modelled as

$$H(f, L) = (a + b \times \sqrt{f} + c \times f) \times L$$

where L is the E-side length, and parameters a , b , and c can be configured through the management interface. A more complete description of DPBO is given in G.997.1 [8]. DPBO does not exclude other methods of downstream power back-off, using direct configuration of the parameter PSDMASKds.

DPBO is enconced in some regulations where exchange-based lines and cabinet-based lines may coexist. DPBO satisfies a simple criterion for spectral compatibility; which is to make the model of crosstalk from cabinet and exchange-based lines equal. However, DPBO was not

designed to optimize DSL line rates, and its use, rather than optimal configuration of the PSD mask, can cause cabinet-based speeds to be below optimal values.

6.3.9 Virtual Noise (VN)

6.3.9.1 Objective – basic variant

The Virtual Noise function defines a Noise Mask (either transmitter or receiver referred), frequency shaped, which at the receiver is converted into a shape that represents the expected noise on the line. This could be seen to have a similar effect to a frequency dependent Target Noise Margin.

Normally the crosstalk noise changes with frequency and VN can attempt to model such change. If the Target Noise Margin is configured only on the peak value it could be too limiting in case of high values of crosstalk noise.

This way the xDSL line is configured to withstand a noise level equal to the configured Virtual Noise Mask, hence decreasing the bitrate with the expectation of increased stability.

6.3.9.2 Target impairments

Incremental changes in crosstalk noise.

6.3.9.3 Involved DSL parameters and/or line characteristics

Below is a list of all Virtual Noise related parameters defined in G.997.1. Virtual Noise is defined for both upstream and downstream so all parameters exists in two versions, one for each transmission direction.

- Downstream/Upstream signal-to-noise ratio mode (SNRMODEds/ SNRMODEus)
The SNRMODE controls if Virtual Noise is enabled or disabled, if it is transmitted or received referred (only for upstream direction) and if the virtual noise scaling factor is enabled.
- Downstream/Upstream virtual noise (VNds/VNus)
The TXREFVN contains a set of breakpoints (up to 32 breakpoints for downstream and up to 16 for upstream) that defines the power of the Virtual Noise to be applied.
- FEXT/NEXT downstream transmitter referred virtual noise (FEXT TXREFVNds/NEXT TXREFVNds)
For ADSL2 Annex C and ADSL2plus Annex C, the downstream transmitter referred virtual noise specified for FEXTR/NEXTR duration is defined as FEXT/NEXT downstream transmitter referred virtual noise.
- Upstream/Downstream virtual noise scaling factor (RXREFVNSFus/ TXREFVNSFds)
This configuration parameter defines the upstream/downstream receiver-referred virtual noise scaling factor.
- Actual downstream/upstream signal-to-noise ratio mode (ACTSNRMODEds/ ACTSNRMODEus)

This parameter reports if Virtual Noise currently is active on the line, if it is transmitted or received referred (only for upstream direction) and if the virtual noise scaling factor is enabled.

6.3.9.4 DQM technique method – basic variant

The Virtual Noise is obtained by specifying different Noise Masks for upstream and downstream. The mask is specified using breakpoints. In particular:

- for ADSL2plus: Up to 16 breakpoints for the downstream VN mask and up to 4 breakpoints for the upstream VN mask;
- for VDSL2: Up to 32 breakpoints for the downstream VN mask and up to 16 breakpoints for the upstream VN mask.

From transmitter mask the receiver calculates the Noise PSD as:

$$\text{Receiver VN} = \text{Transmitter VN} * |H(f)|^2.$$

or for the receiver referred mask, the Receiver VN is configured in the line profile.

The Receiver VN is compared on a carrier basis with the actual noise and the higher value is used by the receiver to determine the bit loading for that carrier. The Receiver VN is also used to calculate the actual NM (Noise Margin) but not for other vectorial parameters like SNR (Signal to Noise Ratio) and QLN (Quiet Line Noise).

In a real network environment, to estimate the noise characteristics to define appropriate VN masks, it is necessary to measure noise parameters on the line for a sufficient time to obtain reliable statistical data. Ideally every line would require a dedicated VN profile but for practical reasons Operators would identify a limited set of VN masks and apply the one that best matches the actual noise on a specific line. The configured VN mask may need to be changed overtime to take into account for possible variations of typical noise conditions.

6.3.9.5 Caveats, trade-offs and limitations

The effectiveness of VN depends on the accurate knowledge of the noise present and expected on the line, both in frequency, amplitude and time. If the VN mask is not well tuned for a given line either an insufficient or a much conservative protection (hence a limited data rate) may result.

On the other hand, defining the VN mask with excessive tailoring to each line leads to a proliferation of the VN profile set. For this reason the trade-off between VN mask tailoring and overall number of masks has to be carefully considered.

A limitation is that the transmitter referred definition of VN is not compatible with the use of UPBO shaping. In this case it is not possible to define a transmitter referred PSD mask since the transmitter PSD is variable with the DSLAM-CPE distance. This is why the ITU-T has specified a receiver referred VN PSD mask for the upstream direction.

Determining the level of noise found on the line in order to utilize VN may be difficult and a long measurement interval may be required to obtain accurate statistics of the noise. Even then these measurements may not provide the necessary detail for setting of the VN masks.

When applied to a DSL Line, VN may reduce the attainable speed of that line while possibly also increasing power consumption. There is a risk of increased crosstalk into neighbouring lines in the same cable/binder if VN is used, especially when higher settings of VN are used. VN should be set to be no greater than the worst-case noise that is encountered routinely on a line. “Worst-case noise” is difficult to define and is an area requiring further study. See NICC DSM report [22] for further information.

6.3.9.6 Related DQM techniques for escalated/combined strategies on the line

This technique is alternative, though with different pros and cons, to the use of SRA, TRA and AMA against crosstalk variations.

6.3.9.7 Energy efficiency impacts

VN impacts energy efficiency by sometimes leading to an increase in transmit power. When VN is used at an excessive level on a DSL Line it can have a detrimental effect on power consumption on the line. For example, Figure 7 of NICC ND 1513 [22] showed cases where VN substantially increased transmit power. In all scenarios examined in [22], there was never a situation where VN reduced power consumption compared with TRA.

6.3.10 SOS - Emergency Rate Adjustment

6.3.10.1 Objective – basic variant

SOS provides means for configuration parameter changes that introduce no transport errors, no latency changes, and no interruption of service.

6.3.10.2 Target impairments

SOS can be used in case of sudden increase of noise such as crosstalk and radio frequency interference (RFI).

6.3.10.3 Involved parameters and/or line characteristics

This sub-section lists all SOS related management parameters defined in G.997.1 [8].

6.3.10.3.1 Configuration parameters

- SOS time window
A non-zero value indicates that the standard SOS triggering criteria are enabled. In this case, this parameter is the duration of the time window used in the standard SOS triggering criteria. The special value zero indicates that the standard SOS triggering criteria are disabled, i.e. vendor discretionary values may be used instead of the values configured in the MIB for the following parameters: minimum percentage of degraded tones, minimum number of normalized CRC anomalies, and SOS time window.
- Minimum percentage of degraded tones
This parameter is the minimum percentage of tones in the MEDLEY set that must be persistently degraded throughout the SOS time window, in order to arm the first sub-condition of the standard SOS triggering criteria.

- **Minimum number of normalized CRC anomalies**
This parameter is the minimum number of normalized CRC anomalies detected in the SOS time window, in order to arm the second sub-condition of the standard SOS triggering criteria.
- **Maximum number of SOS**
This parameter is used in G.993.2 de-activation. If the number of successful SOS procedures performed within a 120-second interval exceeds this parameter, the modem transitions to the L3 state.
- **Minimum SOS bit rate**
This parameter specifies the minimum net data rate required for a valid SOS request.
- **SNR margin offset of ROC**
This parameter is defined as the SNR Margin offset for the ROC channel.
- **Minimum INP of ROC**
This parameter contains the minimum impulse noise protection to apply on the ROC.

6.3.10.3.2 Monitoring parameters

- **Near-end successful SOS count**
This parameter is a count of the total number of successful SOS procedures initiated by the near-end xTU on the line during the accumulation period.
- **Far-end successful SOS count**
This parameter is a count of the total number of successful SOS procedures initiated by the far-end xTU on the line during the accumulation period.

6.3.10.4 DQM technique method – basic variant

SOS provides the receiver with a means to rapidly perform a bit loading reduction in a specified part of the frequency spectrum. In case of sudden noise increases, the signal-to-noise ratio (SNR) at many tones decreases significantly and hence the bit-error-rate (BER) increases substantially above a nominal level. If no action is taken, a re-train of the modems will be triggered and hence the DSL service will be interrupted. If SOS is enabled, retrain can be avoided and the DSL service will not be interrupted. During initialization, the modems may define a number of SOS tone groups in both the upstream and downstream directions. An SOS command request reduces the bit loading on all tones in a group by the same number of bits (multiple groups can be changed in a single command) so that the resulting SNR is sufficiently high and hence the resulting BER is below the nominal level. The SOS command request can also explicitly reconfigure the PMS-TC parameters.

6.3.10.5 Caveats, trade-offs and limitations

SOS is only specified for VDSL2 and is optional.

6.3.10.6 Related DQM techniques for escalated/combined strategies on the line

6.3.10.6.1 Seamless Rate Adaptation (SRA)

Seamless rate adaptation (SRA) is another type of on-line reconfiguration. Unlike SOS, SRA is defined as a procedure to adapt to slowly varying channel conditions. SRA can be used to reconfigure the total data rate by modifying the framing parameters and the bits and fine gains parameters.

After a successful SOS procedure, if the noise condition improves, SRA can be used to gradually increase the data rate; if the noise condition reaches the same level as right before the worsened condition which led to the SOS procedure, SRA can be used to fully recover the data rate before the SOS procedure. Therefore, compared with a full retrain, the combination of SOS and SRA can survive a sudden noise event without interruption of service.

6.3.11 Seamless Rate Adaptation (SRA)

6.3.11.1 Introduction

Seamless Rate Adaptation (SRA) can together with bit swapping and SOS be classified as on-line reconfiguration (OLR), which requires no retraining and operator intervention.

SRA is specified for ADSL2 [3], ADSL2plus [4] and VDSL2 [5] and is optional.

6.3.11.2 Objective – basic variant

The purpose of the function is to keep the noise margin of the line inside a certain operator specified range. For SRA this is done by changing the bit rate based on current observations of the noise margin. Reduced bit rate leads to an increase in the noise margin and vice versa. SRA can also change the gain scaling and hence the transmit power.

The adjustment of bit rate and power is based on continuous monitoring of the noise margin. The adaptation will take place without retraining as a precondition and hence ideally without interrupting the supported services. A suddenly emerging deterioration of the noise conditions may occur so fast that retraining cannot be prevented.

6.3.11.3 Target impairments

The target impairments are crosstalk and “non burst” – at least periodically permanent – noise.

6.3.11.4 Involved parameters and line characteristics

6.3.11.4.1 Input parameters

Adaptation in the two transmission directions is carried out independently (but in the same way). Hence the parameters listed below exist in two versions; upstream and downstream.

- Rate adaptation mode - SRA is only supported by mode 3 (DYNAMIC) and by mode 4 (DYNAMIC with SOS)
- Noise margins: see Figure 4 below (source: G.997.1 [8])

Maximum Noise Margin	Reduce Transmit Power
Upshift Noise Margin	Increase Data Rate if Noise Margin > Upshift Noise Margin for Upshift Interval
Target Noise Margin	Steady State Operation
Downshift Noise Margin	Decrease Data Rate if Noise Margin < Downshift Noise Margin for Downshift Interval
Minimum Noise Margin	Increase Transmit Power. If not possible – reinitialize

Figure 4: Noise Margins

NOTE 1 – Upshift Noise Margin, and Downshift Noise Margin are only supported for Rate Adaptive Mode.

NOTE 2 – Minimum Noise Margin \leq Downshift Noise Margin \leq Target Noise Margin \leq Upshift Noise Margin \leq Maximum Noise Margin.

- Maximum Nominal Aggregate Transmit Power
- Maximum data rate
- Minimum data rate
- Minimum time interval for upshift rate adaptation
- Minimum time interval for downshift rate adaptation

6.3.11.5 DQM technique method – basic variant

Adaptation of bit rate and power is based on current monitoring of the noise margin.

SRA will only be enabled for a given direction if rate adaptation mode is set to “dynamic” or “dynamic with SOS” for the direction.

Adaptation in upstream and downstream directions is carried out independently and autonomously (without intervention from management system and without coordination with other lines) but symmetrically with the receiver as initiator of changing parameters.

Used together with adaptation of transmit power SRA can be described as follows:

The target noise margin is the lower limit of the noise margin which should be achieved in order to complete initialization successfully.

Without SRA enabled power must be reduced unconditionally if the maximum noise margin threshold is passed.

If the minimum noise margin threshold is passed power must be increased. If power cannot be increased further a so-called Loss Of Margin (LOM) defect will occur: The network-element management system shall be notified and retraining will be initiated.

If SRA is enabled the receiver will also monitor if the upshift or the downshift noise margin is passed.

If the current noise margin surpasses the upshift noise margin the bit rate will be increased. Power will only be reduced if the following conditions are fulfilled:

- Bit rate cannot be increased further (conflict with maximum data rate threshold)
- The observed noise margin is larger than the maximum noise margin

If the current noise margin goes below the downshift noise margin the bit rate will be decreased. Power will only be increased if the following conditions are fulfilled:

- Bit rate cannot be decreased further (conflict with minimum data rate threshold)
- The observed noise margin is below the minimum noise margin
- Power is below the maximum power limit

As a kind of hysteresis the relation between observed noise margin upshift and downshift noise margins must be stable for a period specified by the parameters below in order to cause a change in setup:

- Minimum time interval for upshift rate adaptation
- Minimum time interval for downshift rate adaptation

Transmitter and receiver must be capable of renegotiating power and data rate on the fly. Furthermore it must be possible to negotiate the exact time of changing parameters in order to avoid inconsistencies.

Renegotiation of data rate is based on the OLR (online reconfiguration) protocol as specified in G.992.3 [3]. Notice that power adaptation is not based on OLR.

The procedure can be outlined as follows:

- The receiver monitors the noise margin and observes that data rate (or power) must be modified
- The receiver sends a proposal for a revised setup to the transmitter
- The transmitter either sends a synchronization indication to the receiver indicating when the new parameters should be used or a reject with indication of cause. If the receiver does not receive any answer (timeout) or if the proposal is rejected the new setup will be abandoned. A new request can be sent by the receiver immediately after that
- The receiver receives the synchronization indication and receiver and transmitter will modify the setup in accordance with what has been negotiated

Finally notice that the operator can prevent power decrease by setting maximum bit rate to a high value and maximum noise margin to infinite.

6.3.11.6 Caveats, trade-offs and limitations

Customers may be reluctant to accept and have difficulty in comprehending that the data rate of their line may vary over time and partially due to unpredictable causes. Additionally, the TCP/IP and DSL physical layer rates can be misaligned as the rate can change without said change being reflected in network devices such as BRASs/BNGs.

SRA and resulting power changes may cause fluctuating crosstalk, possibly resulting in instability on other lines.

If a heavy deterioration suddenly occurs it may be impossible for the receiver to transfer information of correction (and for the transmitter to transfer a synchronization indication), resulting in a retrain. SRA as a technique is more applicable to slowly varying noise environments.

6.3.11.7 Related DQM techniques for escalated/combined strategies on the line

6.3.11.7.1 FEC and INP

As the name indicates impulse noise protection (INP) based on interleaving and forward error correction (FEC) serves as a countermeasure against noise bursts. The two techniques, INP and SRA, can hence be seen as complementary from a theoretical point of view. Anyhow, implementation of support for simultaneous use of the two techniques encounters some constraints. Below some of the challenges related to implementing coexistence of the two techniques for ADSL2 and ADSL2plus are outlined:

- In ADSL2/2plus the framing parameters are locked during showtime and therefore there are limitations for how bit rate can be changed.
- The VDSL2 standard has several options where different framing parameters (e.g. interleaver depth D) can be changed, and hence SRA is much more flexible for VDSL2.

If we look at the problem for ADSL2/2plus there are two reasons that INP is problematic to implement together with SRA.

Firstly, if data rate is decreased, it will take longer time to pass data through the interleaver and hence delay will increase. Anyhow, this cannot be increased more than specified by the maximum delay parameter.

Secondly, if the data rate increases the number of bits in the DMT symbols will be greater (increase of L). Since the redundancy bits and Reed-Solomon codeword length must be constant (locked framing) this means that S will decrease and hence INP will decrease. Of course INP can only be decreased until it reaches min INP, and thus bit rate cannot be changed in practice if INP is enabled.

6.3.11.8 Energy efficiency impacts

In case of a deterioration of noise margin reduction of bit rate will have precedence over increase of power and in this sense it will reduce the power consumption. The opposite will be the case in case of improved noise margin.

6.3.12 Impulse Noise Protection (INP)

6.3.12.1 Objective – basic variant

Impulse Noise Protection (INP) aims at reduction of bit errors and connection instability problems caused by impulse noise on the DSL line. Such problems are especially noticeable for IPTV where even a small number of bit errors can cause visible artefacts. Re-initialization of the DSL connection causes a complete drop-out for tens of seconds and is detrimental for IPTV since TV customers are used to very high availability figures. Commonly, one visible artefact per hour is accepted for SDTV and one every four hours for HDTV according to TR-126 [12]. For web browsing and similar services, bit errors are normally masked by the inherent retransmission mechanism in TCP and even several errors per second may be unnoticeable apart from the fact that TCP throughput will drop if errors become too frequent. However, re-initializations will still be annoying to web-browsing users.

6.3.12.2 Target impairments

Impulse Noise Protection primarily targets mitigation of the impact impulse noise.

6.3.12.3 Involved DSL parameters and/or line characteristics:

6.3.12.3.1 Configuration parameters

INP is based on Forward Error Correction and Interleaving but these features are not configured directly since it would require knowledge in coding theory to accomplish the desired results. Instead, the detailed low-level configuration is performed by the transceivers, based on the following high level constraints (parameters) that are specified per transmission direction:

- **Minimum Impulse Noise Protection (INPMIN)**
INPMIN is a configuration parameter that specifies the minimum INP value the transceiver shall use (if feasible). It is the length of an error burst (in units of DMT symbols, typically about 250 μ s) that must be tolerated without causing any un-correctable errors.
- **Maximum Interleaving Delay**
The maximum delay parameter specifies the maximum one way delay between the alpha and beta reference points (as defined by the xDSL standards) in the transceiver. It will hence limit the maximum interleaver depth the transceiver can configure. The actual delay on the line is determined by the number of DMT symbols per codeword, S , and the interleaver depth, D . During initialization the transceiver must choose the S and D values so that the actual delay is less than or equal to the configured maximum delay.

6.3.12.3.2 Status parameters

Since the DSL framing parameters can only take certain discrete values, the actual INP achieved is typically larger than the minimum INP required. It is possible to read out the actual INP and various framing parameters related to INP.

- **Actual Impulse Noise Protection (ACTINP)**
The upstream and downstream ACTINP parameters report the actual INP for the respective transmission direction, determined by the framing parameters chosen by the transceiver per each direction.
- **Actual framer settings**
G.997.1 [8] also defines parameters for reporting of all the actual framer settings per transmission direction. These are listed in Section 7.5.2.6/G.997.1 and include parameters like e.g. actual size of Reed-Solomon codeword (NFEC) and actual interleaving depth (INTLVDEPTH).

6.3.12.3.3 Performance counters

Several of the available performance counters are related to INP. Some of the more important are the Forward Error Correction (FEC) and Code Violation (CV) counters:

- **FEC-C, FEC-CFE:** count of the number of successfully corrected FEC codewords in the near and far end.
- **CV-C, CV-CFE:** count of the number of Cyclic Redundancy Check (CRC) errors in the near and far end. A CRC error occurs if at least one FEC codeword was uncorrectable during an overhead frame.

6.3.12.4 DQM technique method – basic variant

Traditional Impulse Noise Protection (INP) in xDSL is based on Forward Error Correction (FEC) where redundant information is transmitted along with the data in order to be able to correct errors occurring on the DSL line. Further, interleaving is used to spread burst errors over multiple codewords in order to be able to handle long impulses. The standards specify a combination of Reed-Solomon (RS) coding and convolutional interleaving. As a side note, FEC in xDSL is actually handled by a concatenated coding scheme where the inner code is a Trellis code handling random, independent, errors and where the outer RS code handles both impulse noise and error bursts resulting from decoding errors in the Trellis decoder. A concatenated code approach is a reasonable trade-off between low residual bit-error rate and decoding complexity. Selection of RS code parameters and interleaving depth is performed by the transceiver, based on the “Minimum Impulse Noise Protection” and “Maximum Interleaving Delay” configuration parameters (see Section 6.3.12.3.1 above).

6.3.12.4.1 Reed-Solomon (RS) Code

The base Reed Solomon (RS) code, used in xDSL is an 8-error correcting code of length 255 symbols (octets) with 239 information octets and 16 redundant octets, i.e. an $(n = 255, k = 239)$ code. This code can be adapted to the needs of the DSL framing structure by removing information octets (shortening) and/or by removing redundant octets (puncturing).

Using xDSL framing parameter naming, the adapted RS-code becomes an $(N, N - R)$ code where N is the resulting codeword length and R is the number of redundant octets.

$N - R$ Information octets	R Redundant octets
----------------------------	----------------------

Figure 5: A Reed-Solomon codeword

The error correcting and detection capability of the RS code depends on the minimum distance, d_{min} , between two codewords, i.e. the minimum number of octet positions that are different between any two valid codewords. Thus, it does not matter if only one or all eight bits in an octet is received in error, it is still counted as one error. Reed Solomon codes are Maximum Distance Separable (MDS) codes, which among other means that the minimum distance between two codewords (the minimum number of octet positions that differ) fulfill the Singleton bound: $d_{min} = n - k + 1$, i.e. $d_{min} = R + 1$. Using traditional decoding, i.e. assuming that the location of octets received in error is not known in advance, the number of correctable octet errors, t , is half the number of redundant octets rounded downwards:

$$t = \left\lfloor \frac{d_{min} - 1}{2} \right\rfloor = \left\lfloor \frac{R}{2} \right\rfloor.$$

Increasing R thus allows correction of more errors in a codeword at the expense of reduced net information rate. If the optional erasure decoding is applied (cf. relevant xDSL standards), the receiver uses channel state information, e.g. from the Trellis decoder in order to determine the error locations. Correcting errors with known location is known as erasure decoding (or erasure filling) and the number of erasures that can thus be corrected (filled) satisfies $f = d_{min} - 1 = R$, i.e. twice as many octet erasures can be filled compared with error corrections. However, this requires a reliable mechanism for finding the error locations.

6.3.12.4.2 Interleaving

Interleaving is a method to increase the burst-error correcting capability of a code without increasing coding and decoding complexity apart from additional memory requirements. With interleaving, burst errors are spread in time over multiple codewords at the receiver. With a block (rectangular) interleaver, the result is a new $(n \cdot D, k \cdot D)$ code, where D is the interleaving depth, i.e. the separation in number of symbols between adjacent symbols from the same codeword. Using xDSL framing parameter notation, interleaving increases the burst-error correction capability by a factor of D , i.e. one error burst of length $t \cdot D$ can be corrected during a block of $N \cdot D$ octets. However, interleaving does not increase the minimum distance of the code, which means that it is not possible to correct arbitrary error patterns of more than t octets within the $N \cdot D$ octets. DSL uses a convolutional interleaver instead of a block interleaver in order to increase the amount of protection for a given memory size.

6.3.12.5 Caveats, trade-offs and limitations

INP is primarily effective against short impulses. Longer impulses such as SHINE or even PEIN impulses may exceed the protection provided by INP, especially if only the mandatory INP parameters of the ADSL2 standard are supported ($INP \leq 2$).

A drawback with FEC is that the redundant information wastes resources even if there are no errors on the line for a long time, e.g. with PEIN impulses.

For high throughput when using INP, the maximum delay should be configured to a sufficiently high value. Attempts to configure high INPMIN values and low maximum delay will lead to substantially reduced bit rates since the fraction of redundant bits will increase. Without erasure decoding, the maximum INP value (in DMT symbols, i.e. 0.25 ms) that can be achieved equals the delay (in ms), e.g. $INP = 4$ with 4 ms delay. However, using such an extreme configuration

means that 50% of the transmitted bits are redundant, i.e. 50% capacity is wasted. The limited size of interleaving memory and restrictions in the possible values of some framing parameters (e.g. D and S) will also contribute to bit rate reductions when using INP. Thus, different actual bit rates may be experienced with different CPEs depending on whether they support only the mandatory values of the framing parameters or some/all of the optional ones.

6.3.12.6 Related DQM techniques for escalated/combined strategies on the line

Related DQM techniques that operate on the same quality-stability axis include:

- **Retransmission**
Instead of using coding and interleaving to handle bit errors it is possible to use a retransmission scheme to recover the corrupted data. Retransmission is described in detail in Section 6.3.13.
- **Impulse Noise Monitoring**
Impulse Noise Monitoring is actually not a technique to protect the system from impulse noise itself but it can be used to analyse and provide statistics of the noise. This can be very helpful when configuring protection schemes like INP and it is hence a powerful tool when it comes to DLM algorithms that aim for automatic configuration of impulse noise protection. More on Impulse Noise Monitoring can be found in Section 6.3.14.7.

Other DQM techniques operating on different quality-stability axes for combined strategies on the line include:

- SNR margin change
- Seamless Rate Adaptation (SRA)
- Virtual Noise (VN)

6.3.13 Retransmission (RTX)

Retransmission is specified in ITU-T Recommendation G.998.4 [9] for ADSL2, ADSL2plus and VDSL2.

6.3.13.1 Objective – basic variant

The Retransmission functionality aims at the reduction of bit errors and connection instability problems mainly caused by impulse noise on the DSL line, by retransmitting corrupted data. This technique has been specified for VDSL2 and for downstream direction of ADSL2 and ADSL2plus. There are two modes for the technique, one of which incurs a constant delay and one which can introduce jitter.

Multiple benefits are foreseen for this technique:

- higher protection than the traditional (Reed Solomon + Interleaving) technique can be obtained;
- lower overhead under the same noise level, hence higher achieved net bitrate. This allows to expand service coverage;
- the average bitrate loss caused by retransmission occurs only in presence of errors;

- the flexibility of this technique allows to use few configuration profiles to cover a broad range of impulsive noise types and combinations;
- retransmission introduces either jitter on transmitted data or a small additional constant delay.

6.3.13.2 Target impairments

Retransmission has proven to be effective against: REIN, SHINE and combinations of REIN and SHINE, though with different degrees of effectiveness.

6.3.13.3 Involved DSL parameters and/or line characteristics

Below is a list of all relevant Retransmission related parameters defined in G.997.1.

- Retransmission mode (RTX_MODE)
This parameter controls the mode of operation of retransmission in a given transmit direction. In ADSL2 and ADSL2plus only the downstream parameter RTX_MODE_ds is relevant.
- "lefr" defect threshold (LEFTR_THRESH)
LEFTR_THRESH specifies the threshold for declaring a near-end "lefr" defect.
- Minimum/Maximum expected throughput for retransmission (MINETR_RTX/MAXETR_RTX)
Specifies the minimum/maximum expected throughput for the bearer channel.
- Maximum net data rate for retransmission (MAXNDR_RTX)
This parameter specifies the maximum net data rate for the bearer channel.
- Maximum/Minimum delay for retransmission (DELAYMAX_RTX/ DELAYMIN_RTX)
Specifies the maximum/minimum for the instantaneous delay due to the effect of retransmission only.
- Minimum impulse noise protection against SHINE for retransmission (INPMIN_SHINE_RTX, INPMIN8_SHINE_RTX)
Specifies the minimum impulse noise protection against SHINE for the bearer channel. The impulse noise protection is expressed in DMT symbols.
- SHINERATIO_RTX
Specifies the SHINE ratio.
- Minimum impulse noise protection against REIN for retransmission (INPMIN_REIN_RTX, INPMIN8_REIN_RTX)
Specifies the minimum impulse noise protection against REIN for the bearer channel.
- REIN inter-arrival time for retransmission (IAT_REIN_RTX)
Specifies the inter-arrival time that shall be assumed for REIN protection.

6.3.13.4 Derived line parameters and/or diagnosis information

Below is a list of all relevant Retransmission related parameters defined in G.997.1.

- "lefr" defects seconds counters
Near-end and far-end count of the seconds with a "lefr" defect present. The near-end counter is only defined in upstream. The far-end counter is only defined in downstream.

The management entity shall generate a 15-min and 24-hour performance history.
- Error-free bits counters
Near-end and far-end count of the number of error-free bits passed over the β_1 reference point, divided by 216. The near-end counter is only defined in upstream. The far-end counter is only defined in downstream.

The management entity shall generate a 15-min and 24-hour performance history.
- Minimum error-free throughput (MINEFTR)
Near-end and far-end reports of the minimum of the EFTR observed over the 15-min or 24-hour accumulation period. The near-end counter is only defined in upstream. The far-end counter is only defined in downstream.

The management entity shall generate a 15-min and 24-hour performance history.
- Retransmission used (RTX_USED)
Specifies whether G.998.4 retransmission is used (i.e. active in showtime) in a given transmit direction. The parameter in downstream is RTX_USED_ds, and the parameter in upstream is RTX_USED_us. In ADSL2 and ADSL2plus only the downstream parameter RTX_USED_ds is relevant.
- Actual net data rate (ACTNDR)
 - In L0 state, this parameter reports the net data rate at which the bearer channel is operating.
 - In L2 state, the parameter contains the net data rate in the previous L0 state.
- Actual impulse noise protection against REIN (ACTINP_REIN)
Reports the actual impulse noise protection (INP) against REIN on the bearer channel in the L0 state. In the L2 state, the parameter contains the INP in the previous L0 state.

6.3.13.5 DQM technique method – basic variant

This technique uses two buffers, one at the transmitter and the other at the receiver. On the transmitter buffer, the transmitted DTUs (Data Transmission Units – minimum transmitting units that contain an integer number of ATM cells or PTM frames) are stored. The DTU contains an integer number of RS Codewords and can optionally contain also a supplemental CRC code.

The receiver, upon receiving the DTU, tests the correctness verifying the RS codewords or the CRC code. In case of an error it sends a message to the transmitter via a feedback channel (RRC: Retransmission Return Channel). At the same time, the receiver stores the incorrect DTU in its buffer and waits for the correct one.

When the transmitter receives the retransmission request, it resends the requested DTU taking it from the transmission buffer. It is allowed to have multiple retransmissions of the same DTU in case of multiple errors due to long impulse noise.

Figure 6 depicts the implementation schema.

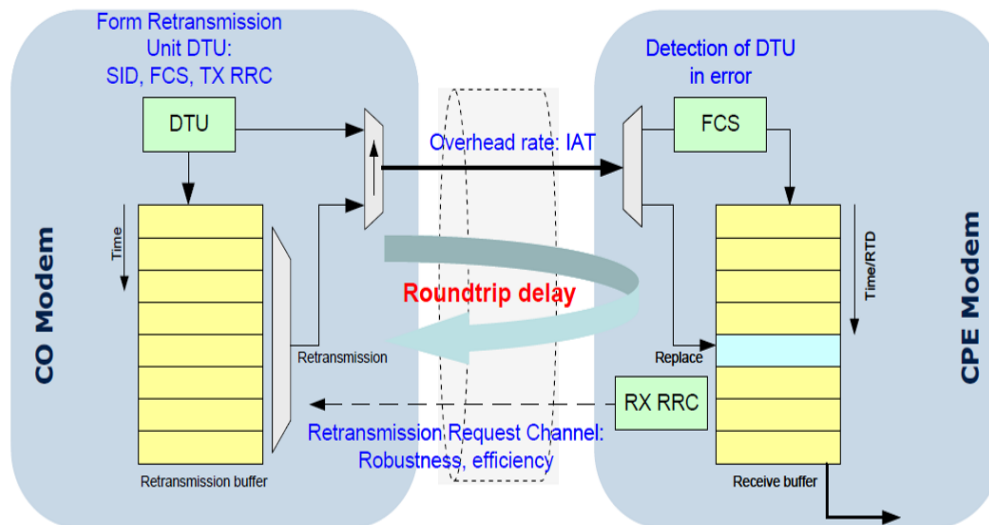

Figure 6: Retransmission implementation schema

The retransmission Unit is called “Universal DTU” and it can be handled on the TPS-TC level or on the PMS-TC level.

The following 4 types of DTU are standardised to favour implementations interoperability:

- without CRC (mandatory for the Transmitter)
- with tail CRC (optional for the Transmitter and mandatory for the Receiver)
- with head CRC option 1 (optional for the Transmitter and mandatory for the Receiver)
- with head CRC option 2 (optional for the Transmitter and mandatory for the Receiver)

The transmitter must support, beyond the mandatory DTU type, at least one of the optional types. Together with the reuse of the interleaving memory for the transmitter buffer, it is allowed to use external buffers to increase the protection for the SHINE noise. However, this memory increase, applicable only for the downstream transmission, also increases the jitter.

6.3.13.6 Caveats, trade-offs and limitations

The maximum protection against a single impulse event of a given length depends mainly on the available memory for the buffers and it is likely to be greater on the downstream side. The maximum protection also depends on the delay and actual data rate since more data needs to be stored in the buffer for higher data rates. This means that for very high bitrates the maximum INP might be limited if there is not enough memory.

A disadvantage of this technique is the jitter introduced on the data flow, especially in the presence of long SHINE impulses.

Throughput can be decreased unpredictably. DSL-layer retransmission is not performed according to traffic type or protocol (e.g. TCP), and hence may retransmit data when it would be better to just drop it.

6.3.13.7 Related DQM techniques for escalated/combined strategies on the line

This is the ideal complement to crosstalk noise controlling techniques (Virtual Noise, SRA) to considerably improve the loop quality in comparison with traditional techniques (Target NM, $INP_{\min}/Delay_{\max}$).

6.3.13.8 Energy efficiency impacts

DSL is traditionally provisioned with 6 dB margin to account for typical noise and channel variations. Lowering the margin can be used for enhancing energy efficiency, or to run at higher line speeds. However, lowering the margin may cause line instability, and so such lines should be monitored with DQM to ensure robust operation. A line can be configured to run with a low margin and use retransmission to correct errors, allowing low transmit power for energy efficiency. Forward error correction and SRA can also be used for this purpose. Also, line speed decreases caused by SRA and jitter introduced by retransmission can negatively affect QoE.

6.3.14 Vectoring

ITU-T Recommendation G.993.5 [6] defines a transmission protocol (vectoring) for use with VDSL2 transceivers to enable cancellation of self far-end crosstalk (Self-FEXT) in the cable.

6.3.14.1 Objective – basic variant

Vectoring is a transmission method that employs coordinated transmission of VDSL2 line signals in a cable to enable the reduction of self-crosstalk between the VDSL2 transceivers within the cable to levels suitable for high quality high-speed services. Figure 7 shows the access architecture for vectored VDSL2. The Vectored VDSL2 DSLAM serves the end users with vectored VDSL2 service via the wire pairs in the access cable connecting to the respective homes; in Figure 7, these are identified as the “Vectored Lines”.

The G.993.5 protocol enables a DSLAM to coordinate the transmission of the VDSL2 signals in a controlled fashion that allows the CPE modems to measure *error samples* on reference VDSL2 sync symbols. The CPE modem then reports this information to the VDSL2 DSLAM via a vectoring back channel for processing. Based on the received error samples from the CPE modems, the DSLAM learns the crosstalk couplings among each of the active lines across all relevant frequencies in the cable. Using knowledge of the channel crosstalk couplings the DSL signals transmitted downstream to each of Vectored Lines are processed to remove the crosstalk. Specifically, in the case of G.993.5 for downstream cancellation, the Vectored VDSL2 DSLAM pre-codes the downstream transmit signals via a pre-coder matrix based on knowledge of the channel crosstalk couplings; the data is pre-coded such that it compensates for the crosstalk injected to the other wire pairs in the cable so that when the signal is received at the CPE, thus the crosstalk is effectively cancelled.

The self-FEXT can also be cancelled in the upstream direction. In this case, the Vectored VDSL2 DSLAM directly constructs a crosstalk cancellation matrix based on the received upstream signals on the Vectored Line connected to that DSLAM. This upstream cancellation

matrix is then used to cancel the crosstalk among the wire pairs in vectored group specific to the upstream frequencies.

G.993.5 defines procedures for joining or adding new lines to a vectored group; similarly, procedures are defined for orderly removing of lines from a vectored group.

The network access cable may have additional wire pairs that do not carry VDSL2 signals but may carry other narrow band services like ADSL to other homes served via the same cable; these wire pairs are labelled as “Non-vectored Lines” in Figure 7. Vectoring only removes crosstalk generated by the VDSL2 signals in the group of vectored lines. Any crosstalk noise caused by signals on the non-vectored lines is considered alien noise that is not removed with vectoring.

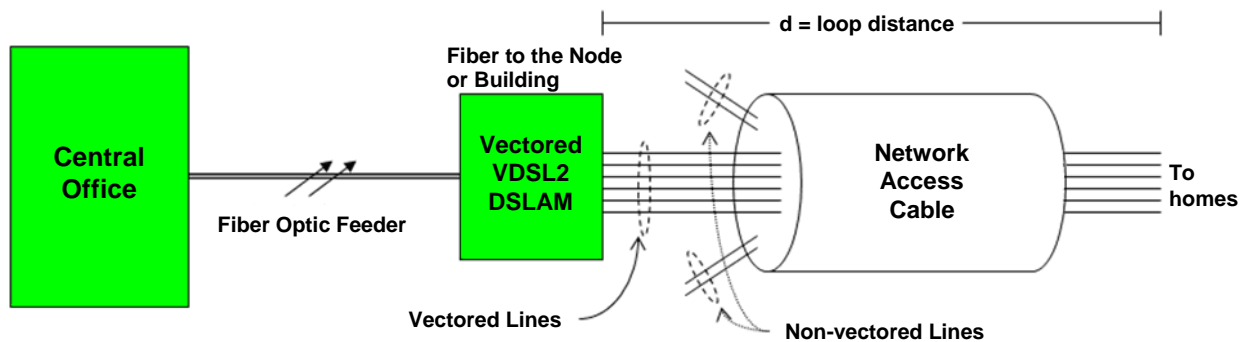

Figure 7: Network Access Architecture supporting vectored VDSL2

6.3.14.2 Target impairments

Vectoring targets the removal of crosstalk injected in the cable by all the VDSL2 signals served out of the Vectored VDSL2 DSLAM. This impairment is often the dominant impairment seen on the VDSL2 lines, and when cancelled with vectoring the DSL quality on the line can therefore approach the best available service quality for the given loop length. However, other impairments such as impulse noise, radio frequency interference (RFI), and crosstalk from other services such as ADSL, are considered as *alien* disturbers, which vectoring does not address. DQM methods for dealing with these alien disturbers, such as DLM/DSM Level 1 and DLM/DSM Level 2 are still valuable when used on vectored lines to ameliorate impairments from these alien disturbers.

6.3.14.3 Involved DSL parameters and/or line characteristics

In addition to defining control and reporting parameters for conventional VDSL2, G.997.1 [8] defines the control and reporting parameters of VDSL2 when operating with vectoring.

Key control parameters in each of the upstream and downstream transmission directions specific to vectoring include the following:

- Vectoring frequency-band control
- FEXT Cancellation Line Priorities
- FEXT cancellation enabling/disabling
- Target net data rate

Key reporting parameters for the upstream and downstream transmission directions specific to vectoring include the following:

- Vectoring Control Entity Identification
- Vectoring Control Entity Port Index
- Linear far-end crosstalk coupling values as a function of sub-carrier frequency

6.3.14.4 DQM technique method – basic variant

Measurement of the error samples, communication of their values to the DSLAM from the CPE, calculation of the crosstalk matrix, pre-coding of the downstream DSL signal, and the actual cancelation of the crosstalk are all real-time calculations that occur in a vectoring capable DSLAM. However a management system can utilize the control parameters listed in Section 6.3.14.3 to optimize the performance of the vectoring. For example due to the processing complexity associated with vectoring, selection of specific lines for vectoring by enabling or disabling vectoring on certain lines, managing the frequencies for which vectoring is applied, and the order of the calculations (the vectoring priority) of the lines can significantly enhance the DSL service improvements realized through vectoring. Such management of Vectored DSL systems is called DSM Level 3.

6.3.14.5 Caveats, trade-offs and limitations

Vectoring is capable of ameliorating the effects of self-crosstalk between VDSL2 lines in the same cable and binder. However it cannot remove the effects of the alien disturbers mentioned above. Because vectoring significantly reduces the effects of the self-FEXT, the effect of these “alien” noises can become more visible on a vectored DSL line, therefore other DQM techniques including DLM/DSM Level 1, DLM/DSM Level 2, must continue to be used on a vectored DSL service to deal with these alien disturbers.

To achieve the maximum benefits of crosstalk cancelation with vectoring, it is necessary to synchronize all the VDSL2 links in the binder. In cases of physical loop unbundling where multiple operators have separate DSLAMs connected to the cable, each vectored group from one operator in the binder will appear as alien disturbers for the vectored groups deployed by the other operator. In this situation, the gain that can be achieved by vectoring will be reduced.

6.3.14.6 Related DQM techniques for escalated/combined strategies on the line

As mentioned above DLM/DSM Level 1 and DLM/DSM Level 2 techniques may be both complementary and necessary due to the increased relative effects of alien disturbers once the self-FEXT is cancelled with vectoring. Other DQM techniques are largely compatible and complementary with use of vectoring.

6.3.14.7 Energy efficiency impacts

Vectoring is computationally intensive, and performing vectoring computations consumes power. This is particularly true with large vector group sizes, which can consume a significant amount of power in the electronic interfaces used to distribute vectoring signals between multiple line cards. The use of vectoring computation resources can be optimized for performance, and for power consumption.

Vectoring computation resources may be insufficient to fully cancel all lines at all frequencies, and the lines and frequencies on which cancellation is enabled can be selected that are most effective for optimizing performance. Lines or frequencies experiencing high crosstalk should have crosstalk cancellation enabled to optimise performance.

Also, to save power, vectoring could be disabled on some lines that don't need very high speeds, or on some frequencies and lines that have little crosstalk. Then these lines or frequencies no longer require vectoring computations and power used by vectoring computations is lowered. These lines should be monitored with DQM to ensure sufficient service performance is maintained.

Vectoring resource allocation could be jointly optimised for both performance and power usage.

6.3.15 Impulse Noise Monitoring (INM)

6.3.15.1 Objective – basic variant

The objective is to monitor the impulse noise on an xDSL line and to record noise statistics. INM can be used to characterize impulse noise on a specific xDSL line and then it improves accuracy, effectiveness and promptness of an assurance intervention on a problematic line. The noise statistic can be used to optimize the line protection configuration to maximize its stability. The impulse noise measurement is done at the receiver side. The receiver calculates the noise impact on the DMT symbols identifying the corrupted ones. Then a time-related statistic on the noise (duration and interval between impulses) is recorded.

The monitoring is performed by the xDSL chipset during normal service operation. Implementation is vendor specific. INM applies only to ADSL2 [3], ADSL2plus [4] and VDSL2 [5] implementations.

6.3.15.2 Target impairments

Target impairments are generally speaking, impulsive noise. However INM is not an active technique, it is only a monitoring one.

6.3.15.3 Involved DSL parameters and/or line characteristics

The Impulse Noise events are detected based on the number and time distribution of severely degraded data symbols. Although the specific criteria are vendor discretionary the involved DSL parameters are the typical PM registers, mainly the SES counters.

6.3.15.4 Derived line parameters and/or diagnosis information

Impulse noise statistics, recorded as impulse duration and inter-arrival time between two impulses:

- INM Impulse Noise Protection Equivalent (INPEQ) histogram 1..17 (INMINPEQ1..17-L) - Count of the near-end INMAINPEQ_i anomalies occurring on the line during the accumulation period.
- INM total measurement (INMME-L) - Count of the near-end INMAME anomalies occurring on the line during the accumulation period.
- INM Inter Arrival Time (IAT) histogram 0..7 (INMIAT0..7-L) - Count of the near-end INMAIAT_i anomalies occurring on the line during the accumulation period.

- INM INPEQ histogram 1..17 (INMINPEQ1..17-LFE) - Count of the far-end INMAINPEQi anomalies occurring on the line during the accumulation period.
- INM total measurement (INMME-LFE) - Count of the far-end INMAME anomalies occurring on the line during the accumulation period.
- INM IAT histogram 0..7 (INMIAT0..7-LFE) - Count of the far-end INMAIATi anomalies occurring on the line during the accumulation period.

6.3.15.5 DQM technique method – basic variant

The basic scheme is shown in Figure 8.

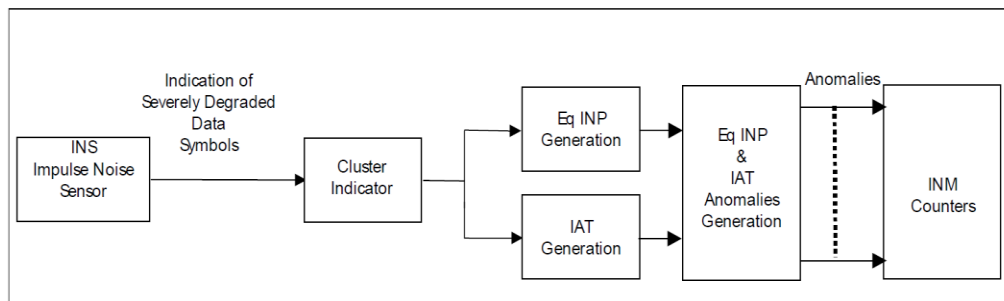

Figure 8: INM scheme

Functional blocks:

- **INS: Impulse Noise Sensor.** This element detects if a DMT symbol is severely degraded or not. A severely degraded symbol is defined as a symbol that will cause an error on the gamma interface if no Impulse Noise Protection functionalities (e.g. INP/Interleaving) were implemented.
- **Cluster Indicator.** This element creates the clusters of degraded DMT symbols.
- **Eq INP: Equivalent INP.** For every received cluster, these parameters are calculated:
 - Impulse Noise Cluster Length (count of symbols in the cluster)
 - Impulse Noise Cluster Degraded data symbol (count of degraded symbols in the cluster)
 - Impulse Noise Cluster Gaps (number of gaps – sequences of correct symbols – between groups of degraded symbols)
 - Equivalent INP (INP equivalent value needed to protect from cluster events).
- **IAT Generation: Inter Arrival Time Generation.** This element calculates inter-arrival time defined as the distance between two identified degraded symbols clusters.
- **Eq INP & IAT Anomalies Generation and INM Counters.** These elements receive the data and record discrete time statistics. Possible values are:
 - 8 possible values, user defined, for the inter-arrival intervals
 - 17 possible values for the duration (one value for each event with equivalent INP from 1 to 16, plus a value for events with INP>16).

6.3.15.6 Caveats, trade-offs and limitations

Collection of INM measurements over many lines produces a lot of data that have to be elaborated to use them on a network. Collected data are not always easy to interpret and to employ. Then, for an efficient use of this functionality, an exhaustive test and tuning phase could be required.

Moreover, working on a single line basis could lead to a proliferation of configuration profiles. On the other hand, post-elaboration of INM measurement to extract a set of general profiles to protect against impulse noise could be process intensive and may result in a sub-optimal configuration.

6.3.15.7 Related DQM techniques for escalated/combined strategies on the line

This technique does not depend on other functionalities since it works only in monitoring mode. The corrective actions depend on other techniques.

6.4 Test Measurement Capabilities

6.4.1 Single Ended Line Test (SELT)

SELT is a standardized measurement technique specified in G.996.2 [7].

6.4.1.1 Objective – basic variant

The original application for SELT is estimation of line capacity and line characteristics – detection of and classification of errors is a more recent application aiming at reducing OPEX costs for operators by minimizing truck rolls and support costs. The following is a list of the most important applications for SELT:

- Estimation of line capacity (attainable bit rate)
- Guidance for deployment and configuration of lines
- Troubleshooting: Detection, classification and localization of line impairments

6.4.1.2 Involved parameters and line characteristics

Until recently, there was no standard for SELT and most implementations on the market today are vendor-specific. This section gives examples of common input and output parameters that exist in SELT implementations. Thus, it is not entirely in accordance with G.996.2.

6.4.1.2.1 Input parameters

Seen from the operator's point of view the number of input parameters should be reduced to the extent possible. There are three main groups of configuration parameters:

Parameters that will have impact on the measurements include:

- Echo measurement duration
- Transmit PSD
- Noise measurement duration
- Noise measurement frequency band

Parameters that will affect estimation of line characteristics include:

- POTS/ISDN splitter type at DSLAM
- A priori cable information, e.g. Velocity of Propagation (VOP) or a list of cable models

Parameters that will affect the capacity estimation include:

- Band plan and PSD for the capacity estimation
- Line profile parameters, e.g. SNR margin

6.4.1.2.2 Output parameters

Parameters comprised in current version of G.996.2:

Scalars:

- Loop length
- Downstream capacity
- Upstream capacity
- Termination type (e.g. open, short, active CPE)

Vectors:

- Uncalibrated echo frequency response per subcarrier
- Variance of echo frequency response per subcarrier
- Line insertion loss (attenuation) per subcarrier
- Measured near-end line noise per subcarrier

Parameters not present in the current version of G.996.2:

Scalars:

- Attenuation at a given frequency (e.g. 300 kHz or 1 MHz)
- Mean upstream noise level

Vectors:

- Estimated input impedance of the line per subcarrier
- Signal to Noise Ratio per subcarrier
- Estimated bit loading per sub carrier
- Time Domain Reflectometry (echo versus distance)

6.4.1.3 Derived line parameters and/or diagnosis information

SELT has a great potential for troubleshooting faulty lines. Most faults that affect DSL operation (capacity reduction and/or instabilities) will result in an impedance discontinuity on the line, thus causing a reflection that may or may not be visible in a TDR graph depending on resolution and

type of fault (reflection magnitude may be too weak for some faults). One exception is degraded loop balance; this will instead lead to increased noise levels and might thus be seen in the noise measurements.

Examples of line impairments that affect DSL operation include:

- Bridged taps
- Split pairs
- Contact resistance
- Contact between pairs
- Interruption of one wire
- Interruption of both wires
- Load coils
- Contact to ground
- Strong noise ingress (e.g. crosstalk, impulse noise or RFI)
- Humidity in cables

Many of these faults will be possible to detect and localize with SELT but it will not always be possible uniquely to identify the type of fault. The diagnosis can be based on comparing measurements over time – i.e. storing measurements as reference measurements to be used for later comparison and tracking trends. Another option is comparing measurement results for lines belonging to the same cable to identify a source of error affecting several lines. Here correlation analysis can be applied.

Certain faults (e.g. foreign voltages and high-resistance leakage to ground) will only affect POTS operation and not DSL. Such faults cannot be detected by SELT but in all-digital environments without POTS, these faults will most likely not cause any harm and thus there is no immediate need for repair.

6.4.1.4 DQM technique method – basic variant

A typical SELT measurement consists of the following parts:

- Echo measurement
- Near-end noise measurement
- Post-processing to estimate line characteristics
- Post-processing to estimate line capacity

6.4.1.5 Caveats, trade-offs and limitations

The performance of SELT might be affected by the far end termination type since the magnitude of the received echo is dependent on the reflection. The far end termination can be detected by post-processing of the UER and this can be used as an indication of the achievable SELT reach. Below follow a short description of the most common far-end termination types.

- No CPE present/line open-ended

For service pre-qualification SELT is normally measured *without* a CPE at the far end of the line. This gives the best reach and accuracy since in case of absence of the CPE the far end will give total reflection of the measurement signal.

- **Active CPE present**
The ITU-T Recommendation G.994.1 handshake tones transmitted by a CPE will disturb the measurement, thereby reducing reliability of the measurement if proper care is not taken during the post-processing. Also, when the CPE is active its impedance is typically well matched to the line and the reflection will thus be weak resulting in a reduced SELT reach
- **CPE unpowered present**
A CPE in power-off state will not transmit handshake tones but it will still have partial impedance matching which means that the received echo will be weaker than for an open-ended line.

6.4.2 Dual Ended Line Test (DELT)

Dual Ended Line Test (DELT) is a standardized measurement technique also known as “loop diagnostics” as described by ITU-T Recommendations G.992.3, G.993.2 and G.997.1. DELT is also within the scope of ITU-T Recommendation G.996.2 but the work with that specification is currently under progress.

6.4.2.1 Objective – basic variant

DELT measures several different parameters that can be used for performance estimation, qualification, and troubleshooting of a DSL channel. With the use of inbuilt testing methods such as SELT and DELT the need for costly truck rolls and standalone measurement test heads can be reduced.

An example of using DELT results for troubleshooting is to detect strong noise sources by analysing the quiet line noise. Figure 9 shows the QLN results from a DELT measurement of a line disturbed by a broken power supply radiating strong REIN. Such a disturbance is characterized by strong and short repetitive noise burst that can severely degrade DSL services. With the use of DELT the strong peaks can be detected and a technician can be sent out to remove the disturber, or appropriate mitigation schemes can be configured to recover QoS for the service. Note that this is a single example and there are many more use cases where DELT is useful.

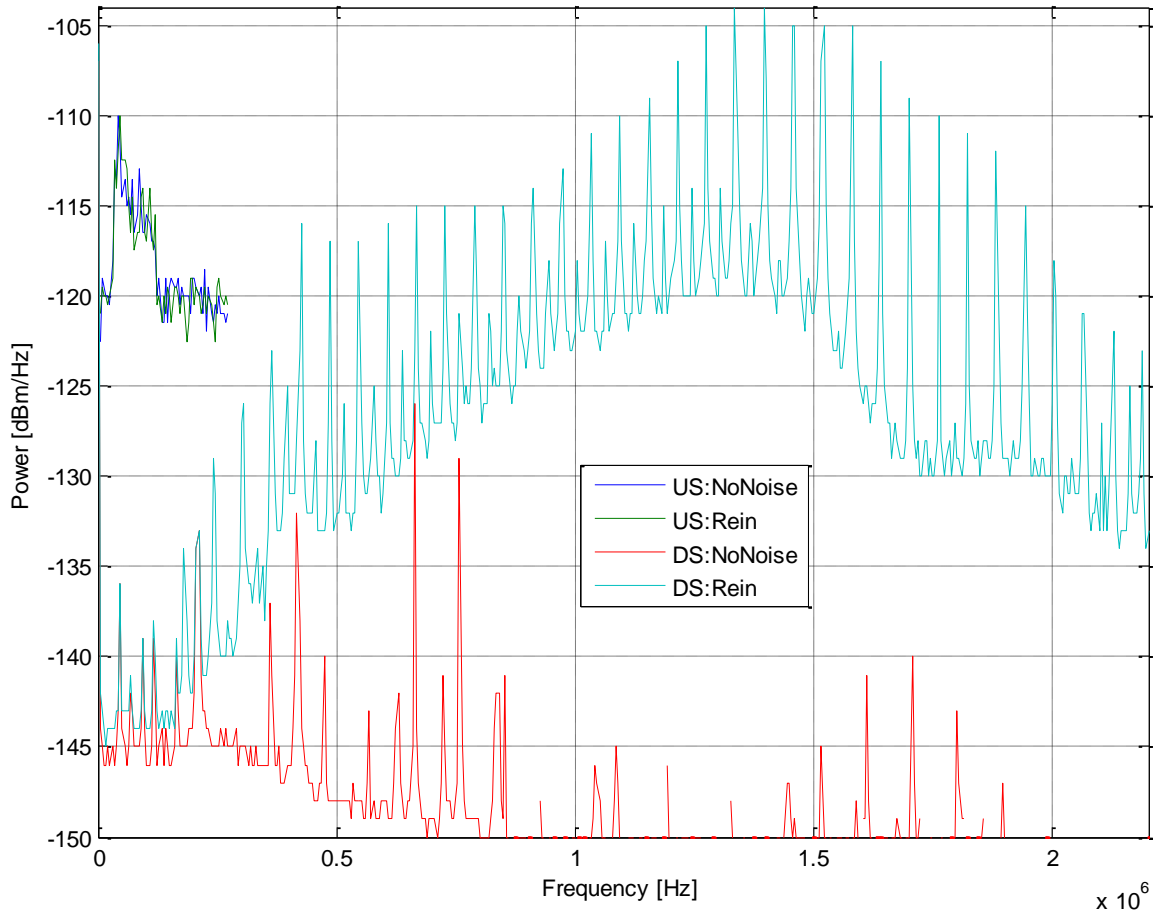

Figure 9: DELT QLN measurement of a REIN disturber (broken power supply)

6.4.2.2 Involved DSL parameters and/or line characteristics

6.4.2.2.1 Input parameters

There are no configuration parameters for DELT since the standard defines some default values that shall be used for PMD configuration during loop diagnostic. However, there is one parameter defined to force the line into loop diagnostic mode:

- Loop Diagnostic Mode Forced (LDSF)

Note that the DELT parameters are automatically measured during initialization and some parameters are also updated during showtime. So, it might not be required to force loop diagnostics mode for retrieving the data.

6.4.2.2.2 Output parameters

For all output parameters the xTU-O measures the upstream values and the xTU-R measures the downstream values, i.e. all parameters are reported for both upstream and downstream.

Scalars:

- Loop Attenuation (LATN). Reported per band.
- Signal Attenuation (SATN) Reported per band.
- Signal-to-Noise Ratio Margin (SNRM)
- Attainable Net Data Rate (ATTNDR)
- Actual Aggregate Transmit Power (ACTATP)
- Quiet Line Noise PSD Measurement Time (QLNMT)
- QLN subcarrier group size (QLNG)
- H(f) linear representation Scale (HLINSC)
- H(f) linear subcarrier group size (HLING)
- H(f) logarithmic Measurement Time (HLOGMT)
- H(f) logarithmic subcarrier group size (HLOGG)
- SNR Measurement Time (SNRMT)
- SNR subcarrier group size (SNRG)

Vectors:

- Channel Characteristics per subcarrier, linear (Hlin)
- Channel Characteristics per subcarrier, logarithmic (Hlog)
- Quiet Line Noise per subcarrier (QLN)
- Signal-to-Noise Ratio per subcarrier (SNR)

6.4.2.3 Derived line parameters and/or diagnosis information

As the main objective of DELT is troubleshooting it is a great tool for line diagnosis. With the QLN measurement severe noise, e.g. RFI, impulse noise and strong crosstalk, can be detected at both sides of the loop which neither is possible with MELT nor SELT.

The direct measurement of SNR and transfer function H(f) can be analysed to detect copper faults such as bridged tap. Figure 10 shows an example of the detection of bridged taps. Hlog(f) from three different DELT measurements are shown; one reference line with one single section, then the same line but with a connected 30 m bridged tap, and then the line but with a 200 m bridged tap connected. As can be seen the bridged tap causes large dips in the transfer function which will reduce the performance of the DSL transmission.

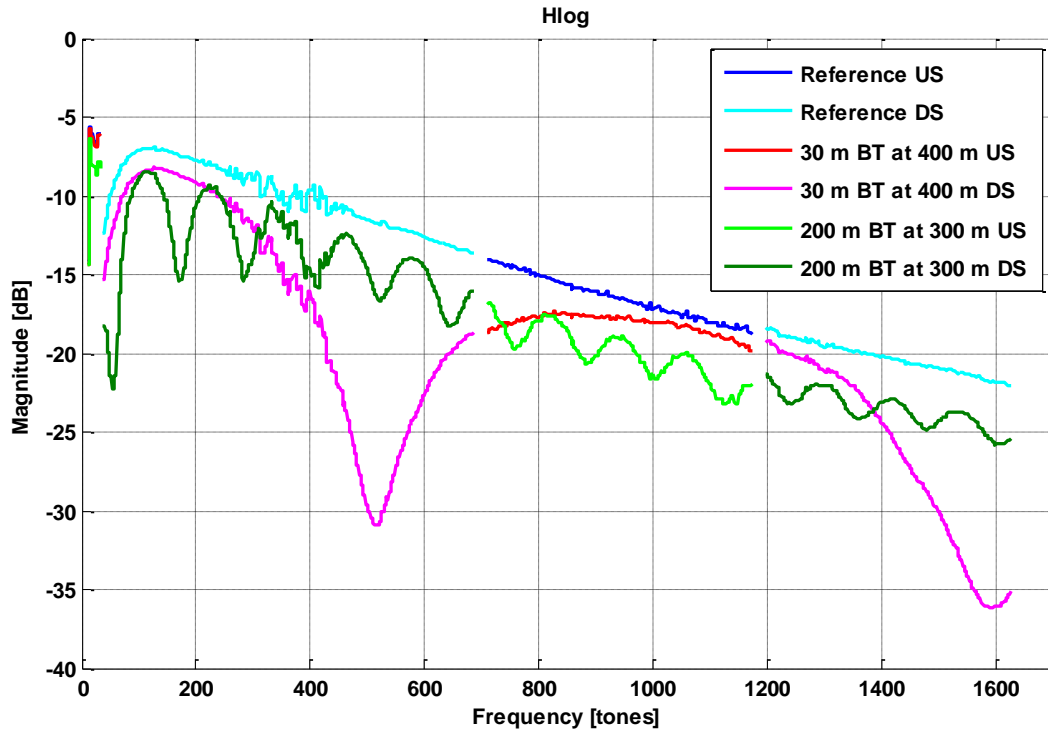

Figure 10: Hlog(f) from DELT measurements of a one section line, a line with a 30 m bridged tap and a line with a 200 m bridged tap.

6.4.2.4 DQM technique method – basic variant

The DELT procedure utilizes both the xTU-O and xTU-R to measure the line conditions at both ends of the line. A procedure similar to what is used for initialization of regular DSL transmission is used to measure channel characteristics such as transfer function, signal-to-noise ratio and quiet line noise. The parameters measured by the xTU-R are reported back to the xTU-O in order to be available for read out. The reporting uses a robust communication scheme and retransmission to minimize the risk of corrupted measurement results.

6.4.2.5 Caveats, trade-offs and limitations

As the DELT requires communication between both the xTU-O and xTU-R it is not possible to perform a test if the line conditions are so bad that communication can't be established, or if the xTU-R is removed or powered off. In that case SELT and/or MELT needs to be used for troubleshooting and/or line qualification. Also, if a service is used on the line it temporarily needs to be disrupted while performing the DELT measurement. However, note that some of the parameters are updated during showtime and if only those are of interest a retrain is not necessary.

6.4.3 Metallic Line Test (MELT)

6.4.3.1 Objective – basic variant

The MELT functionality allows performing a set of DC or low frequency measurements on the line to characterize main electrical parameters. These measurements are useful to attribute

connectivity problems (e.g. low performances, stability problems, etc) to physical impairments and may also help to localize the fault.

These measurements could be done without interrupting the electrical continuity of the line.

MELT is inherently a monitoring technique but certain measurements require the injection of a signal on the line which could interfere with POTS and broadband services.

This technique allows detection of electrical faults like short circuits, interruptions, low insulations, foreign voltages, parasite capacitances etc.

6.4.3.2 Involved DSL parameters and/or line characteristics

6.4.3.2.1 Input parameters

The electrical measurements on the line are defined in ITU-T Recommendation G.996.2:

- R_{TR} – DC resistance between tip and ring
- R_{RT} – DC resistance between ring and tip
- R_{TG} – DC resistance between tip and GND
- R_{RG} – DC resistance between ring and GND
- C_{TR} – Capacitance between tip and ring
- C_{TG} – Capacitance between tip and GND
- C_{RG} – Capacitance between ring and GND
- $V_{TR,DC}$ – DC foreign voltage between tip and ring
- $V_{TG,DC}$ – DC foreign voltage between tip and GND
- $V_{RG,DC}$ – DC foreign voltage between ring and GND
- $V_{TR,AC}$ – AC foreign voltage between tip and ring
- $V_{TG,AC}$ – AC foreign voltage between tip and GND
- $V_{RG,AC}$ – AC foreign voltage between ring and GND
- $f_{TR,AC}$ – AC voltage frequency between tip and ring
- $f_{TG,AC}$ – AC voltage frequency between tip and GND
- $f_{RG,AC}$ – AC voltage frequency between ring and GND
- $C_{TR,HV}$ – Loop capacitance with high metallic voltage
- $R_{TR,HV}$ – Loop resistance with high metallic voltage
- $R_{RT,HV}$ – Loop resistance with high metallic voltage

Further parameters can be measured like complex admittance with controlled voltage or high metallic voltage.

6.4.3.3 Derived line parameters and/or diagnosis information

The electrical measurements can be used to diagnose the following impairments:

- open wire failure (one or both wires, estimated distance)
- short circuit failure (one or both wires to ground or tip to ring)
- leakage identification (one or both wires to ground)
- resistive fault to GND (one or both wires)
- foreign voltage impairment identification (probable source, hazardous level)

6.4.3.4 DQM technique method – basic variant

ITU-T Recommendation G.996.2 [7] specifies a reference model for a generic MELT implementation. The model must respect the functional schema shown in Figure 11.

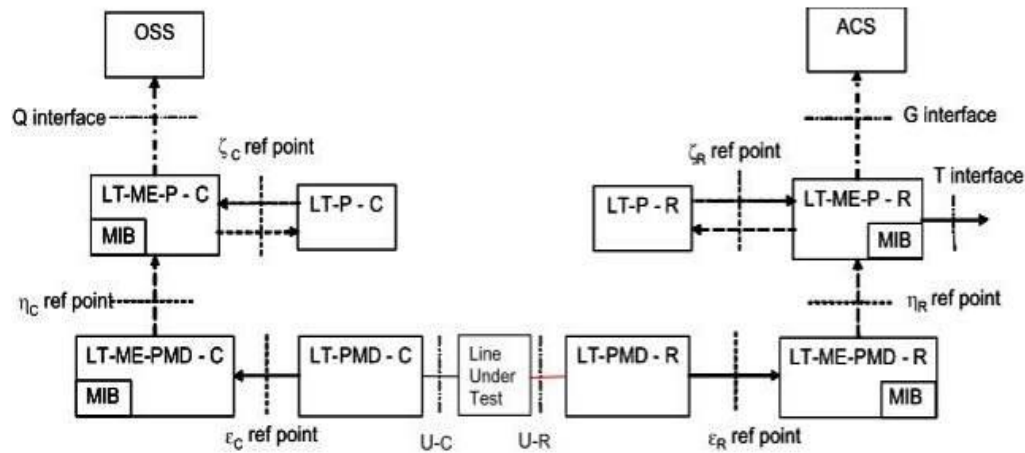

Figure 11: MELT reference model

This functional schema is symmetric at transmitter and receiver side. There are four main blocks:

- LT – PMD (Line Test – Physical Medium Dependent): performs measurements on the physical medium to which the line test device is connected;
- LT – P (Line Test – Processor): transforms the measurement parameters into derived parameters;
- LT – ME – P (Line Test – Management Entity – Processor): manages the LT – P block and interfaces the OSSs;
- LT – ME – PMD (Line Test – Management Entity – Physical Medium Dependent) manages the LT – PMD block and provides to the LT-ME-P access to measurement parameters.

OSS can start measurement on a specific line and then read the measure and the diagnosis. This technique is then most useful during the assurance phase, to investigate stability problems or after complaints.

6.4.3.5 Caveats, trade-offs and limitations

Generally speaking, a stand-alone solution must share the same physical medium with the Narrowband/Broadband transceiver, forcing the use of equipment like an Automatic Main Distribution Frame (MDF). Another approach makes use of an integrated solution on the same transceiver board. However, this solution is easily applicable only on new equipment. On legacy equipment, a line card change (and related software upgrade on both the equipment and Element Management System) may be necessary.

To maximize the reliability of the diagnosis, the electrical characteristics of the cable must be accurately known.

6.4.3.6 Related DQM techniques for escalated/combined strategies on the line

This technique does not depend on other functionalities since it works only in monitoring mode. The corrective actions depend on other techniques.

6.5 External DQM Techniques

6.5.1 Static Quality Management (SQM) Techniques

6.5.1.1 Objective – basic variant

The objective of Static Quality Management (SQM) is to set the DSL line parameters in order to give an expected performance that is appropriate for either a particular service or regulatory environment. SQM consists of a base of Static Spectrum Management (SSM) and rudimentary configuration of the line parameters.

Static Spectrum Management is a method by which the control of the noise environment in a cable is performed by limiting the spectral power of the signal on each cable pair. The limits are usually prescribed by masks much like those in equipment standards and Access/ Injection points at different locations can be assigned different masks. Usually all the lines ending at one location have the same mask irrespective of who is using them and for what.

The principle objective is to limit the crosstalk to levels that will rarely cause problems. This is principally done by limiting the transmit PSD of all DSLs. An example of a spectral limit using SSM is shown below in Figure 12.

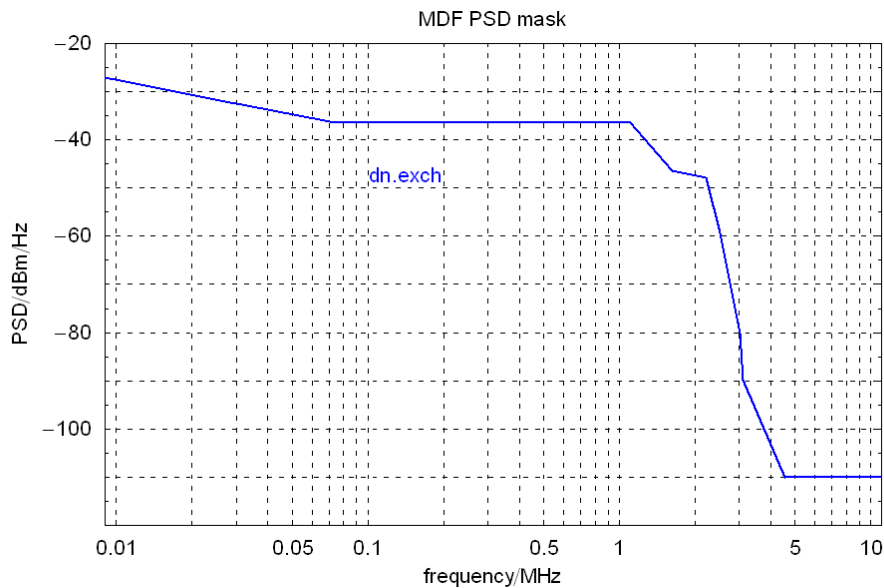

Figure 12: Example MDF PSD mask

The spectrum management problem space can expand when DSLAMs are installed at multiple locations. This case is handled in different ways in different regulatory regimes [23], [24]. One such way [24] is by stipulating that the PSD launched from a Sub-loop Distribution frame (SDF such as a cabinet) is shaped to limit the impact of its crosstalk into systems launched from an MDF. This can be done by assigning the SDF a value determining the electrical attenuation from

the MDF and this value is utilized to determine the shaping of the PSDs for the services launched from that SDF. An example of such a method is Downstream Power Back-Off (DPBO) defined in ITU-T Recommendations G.992.3 [3], G.993.2 [5] and G.997.1 [8].

The signal power from the CPE can also be reduced in order to reduce the FEXT from a short line into a longer line sharing the same binder. This is referred to as Upstream Power Back-Off.

As explained in 6.3.3, it is also possible to save power by spectral optimisation. However, spectral optimisation aiming to improve energy efficiency may conflict with spectral optimization algorithms that maximize crosstalk performance. For example, a short line may use more total power because it is using higher frequencies in order to be polite to neighbouring long lines that cannot use these frequencies because of the higher attenuation. In this case politeness and power usage need to be balanced and optimized in a particular environment. In these cases use of dynamic spectral optimisation may be more appropriate (see section 6.5.2).

In addition to Static Spectrum Management, Static Quality Management can be performed by rudimentary configuration of the DSL line parameters according to the expected service. For example where a best efforts internet browsing service that is focused on speed is required, then a fast mode fully rate adaptive service with low target margins is appropriate. However, where an error free service such as IPTV is required, then a fixed rate DSL profile with high levels of Forward Error Correction is appropriate. Examples of DSL line profiles for IPTV services are discussed in more detail within Section 6/TR-176 [13] and the parameters discussed are equally relevant to VDSL2 as ADSL2plus.

6.5.1.2 Target Impairments

SQM techniques are designed to ameliorate the effects of:

- Noise, including
 - Crosstalk from other DSLs in the same cable/binder
 - Ingress noise from external sources including impulse noise
- Cable and inside wiring impairments

6.5.1.3 Involved DSL parameters and/or line characteristics

The SQM techniques utilize the standard set of DSL profile configuration parameters but do not actively retrieve the performance statistics and “tune” the line profile based upon actual performance. The parameters that SQM techniques focus on would be setting the following appropriate to the service being utilized:

- Target Downstream/ Upstream SNR
- Maximum Downstream/ Upstream rate
- Maximum Downstream/ Upstream Interleaving Delay
- Minimum Downstream/ Upstream INP

The PSD utilized does not tend to be set via the DSL line profile, but is embedded within the DSLAM line card transceiver and CPE although where a Cabinet Assigned Loss (CAL) value is utilized to control the PSD, this tends to be set on the DSLAM during commissioning.

6.5.1.4 Caveats, trade-offs and limitations

Static Quality Management techniques do not take into account the actual performance of the loop. This can lead to the following situations where the applied line profile:

- prevents the end-users by preventing them from utilizing the actual capacity and capability of their line.
- does not provide sufficient protection against error sources and does not sufficiently address cases where the line performance is below the requirements for the expected service.
- means that the service works, but the line consumes more power than is actually required to support the service.

While Static Spectrum Management allows for the co-existence of different services it does allow for lines to launch more power to the line than necessary to support a particular service and does not promote the most efficient use of the available spectrum.

6.5.2 Dynamic Spectrum Management (DSM) Techniques

6.5.2.1 Objective – basic variant

A main benefit of Dynamic Spectrum Management (DSM) is its ability to “tune”, that is to optimize the DSL Profile of each line. DSM re-profiling is based on analysis of on-line and historical observations of the DSLs physical-layer performance parameters to create a self-constructed characterization of a service-provider’s lines. Appropriate exploitation of the inherent dynamic capabilities provided in standards compliant DSLs combined with appropriate setting of the DSL Profile by an OSS/EMS/NMS which supports DSM analysis allows for improved line stability and rate/reach. DSM techniques can also reduce power consumption of the DSL transmitters while maintaining or under certain situations even enhancing rate/reach performance, which could reduce overall network power consumption. A system that supports DSM is described in a reference model in the ATIS Dynamic Spectrum Management TR [21] where it is referred to as a Spectrum Management Center (SMC). The relationship between the ATIS DSM TR reference model and the Broadband Forum DQM Functional architecture is in the informative Appendix 1/TR-198 [15].

The ATIS DSM TR describes three levels of DSM of increasing coordination of Line Configuration and spectra

- *DSM Level 1* occurs where each line is monitored and configured independently to assess the line and noise conditions of that single line. DSM Level 1 is also known as Dynamic Line Management (DLM). DSM Level 1/DLM techniques typically improve line performance, that is rate/reach, stability or power consumption by manipulation of scalar parameters such as the Line Rate, Margin controls, FEC and INP parameters in DSL configuration profiles. DSM Level 1/DLM techniques currently are widely deployed in a number of Network Providers DSL networks worldwide.
- *DSM Level 2* techniques optimize the spectrum and performance of multiple lines in a cable/binder as the lines are monitored to assess the noise and line conditions in the cable. In DSM Level 2 the interaction from one line (disturber) into another line (victim) is taken into account when configuring individual lines in the binder. The line that is configured can be

either victim or disturber. The goal of DSM Level 2 optimization is coordinated optimization of all lines in the cable/binder. DSM Level 2 techniques can utilize all DSM Level 1/DLM techniques while also using coordinated modification of the spectrum parameters on DSL lines in order to achieve the benefits across multiple lines in a cable/binder. DSM Level 2 is currently emerging into deployment.

- *DSM Level 3* is the management of Vectoring techniques, such as those described in G.993.5 [6], to cancel crosstalk between DSL lines. Vectoring is described in more detail in Section 0.

In addition to increasing the stability and rate/reach of DSL services, the data used in performing DSM analysis and the output from DSM optimization algorithms can also support diagnostic analysis on a DSL service.

6.5.2.2 Target impairments

DSM techniques are designed to ameliorate the effects of:

- Noise, including
 - Crosstalk from other DSLs in the same cable/binder
 - Ingress noise from external sources including impulse and time-varying noise
 - Effects of DSL services initializing on victim lines (non-stationary noises)
- Cable and inside wiring impairments
- Problems that effect DSL service penetration (That is reduced DSL footprint due to the aggregate effect of service impairments)
- Excessive energy use by DSL services.

6.5.2.3 Involved DSL parameters and/or line characteristics

A list of G.997.1 [8] parameters related to DSM analysis and service reconfiguration is provided in the ATIS Dynamic Spectrum Management TR [21]:

- DSM Level 1 – the line is typically re-profiled for increased stability and line rate by manipulating line parameters such as the line rate, margin, INP, Interleave and FEC parameters.
- DSM Level 2 – Additional parameters related to PSD such as manipulations of PSD masks, or setting of CI-Policy are used in addition to the Level 1 manipulations to improve line rate and stability. The transmit PSD mask, PSDMASK, is the primary configuration parameter. The following configuration parameters may also be used: MAXNOMPSD, CARMASK, and VDSL2-CARMASK
- DSM Level 3 – utilizes vectoring and the G.997.1 [8] parameters that support monitoring and configuration of G.993.5 [6] compliant modems as well as parameters used in DSM Levels 1 and 2.

Additionally, performance can be monitored with the following parameters actual data rate, actual noise margin, ACTATP; as well as with the following error counters: CV-C, FECS-L, ES-L, SES-L, LOSS-L, and UAS-L.

6.5.2.4 Derived line parameters and/or diagnosis information

Although DSM techniques are oriented toward the optimization of DSL line performance, the analysis methods and algorithms using standard DSL reported parameters to determine the appropriate configuration of a DSL line also can be used to generate diagnostic information regarding the loop's and cable's physical characteristics, conditions in the customer's premises, the long term performance of the DSL service, the noise environment affecting the service and the configuration of the service.

6.5.2.5 Caveats, trade-offs and limitations

- DSM Techniques are affected by the quality of the loop performance information available by the DSL modem chipset, the DSLAM and CPE. DSM implementations thus may have to implement work-arounds should a particular DSLAM type not implement or incorrectly implement a standardized G.997.1 parameter.
- Since applying a new profile, per the existing DSL standards, requires a retrain of the DSL connection, implementing the optimized profile will require an interruption in the DSL service to the end-customer. DSM systems thus should be designed to perform this re-profiling at a time least likely to adversely affect the end-customer's perception of the DSL service.
- The quality of the DSM systems ability to improve a DSL service is dependent on the DSM algorithms implemented in the SMC. Some of these algorithms are not standardized and their capabilities are thus the responsibility of the designer of a DSM SMC. A discussion and guidance on the criteria for quality of different DSM Level 1/DLM techniques (in the specific environment of the UK access network) is provided in the Report on Dynamic Spectrum Management (DSM) Methods in the UK. Access Network. NICC ND 1513 [22]. DSM Level 1, 2 and 3 techniques are presented in the ATIS DSM report [21].

6.5.2.6 Related DQM techniques for escalated/combined strategies on the line

DSM works with DQM techniques such as SOS, Retransmission (G.998.4 [9]) and most existing DSL management tools.

6.5.2.7 Energy Efficiency impacts

DSM techniques can reduce energy consumption of DSL Lines while maintaining or under certain circumstances even increasing rate reach and stability of the lines. This is accomplished by selecting the optimum transmit spectra configuration of the line with the minimum possible crosstalk into other lines allowing other lines to in turn reduce transmitted power (See Appendix A). For example this can be accomplished by configuring the bit loading to improve power usage at start-up, by performing "waterfilling" to maximize the bit rate while minimizing the total average power.

In the case of DSM Level 1/DLM techniques each DSL line in the cable binder will be optimized separately and the energy savings can emerge as a side effect of a configuration with optimal margin and rate reach settings. In the case of DSM Level 2 and DSM Level 3 multiple (or all) DSL lines in the cable/binder are optimized together to achieve stability, rate reach, and crosstalk reduction and the analysis can potentially provide transmit power reductions.

The UK ANFP version 5 [24] has a section that allows the upstream PSDMASK of a single line to be exceeded by 5 dB if the average PSD of all lines is lowered by 2 dB. This is an example of spectral flexibility that can be exploited to achieve network-wide power-savings.

This technique configures the transmit spectra of DSL lines to minimize power usage. Bit loading may be configured to optimize power usage at start-up, such as by performing “waterfilling” to maximize the bit rate while minimizing the total average power. The transmit PSD resulting from “waterfilling” is generally not flat.

The DQM system may adaptively move transmit power from higher frequencies into lower frequencies, since there is less attenuation at lower frequencies and so the total transmit power may be lowered. Bits can be swapped from the sub-carriers using the highest incremental energy per bit into the sub-carriers needing the least incremental energy per bit. Subcarriers at frequencies with high attenuation may be turned off entirely.

6.5.2.8 Pros and cons associated to the Energy Efficiency impacts

DSM techniques can be used to reduce energy consumption of a DSL transceiver while potentially simultaneously improving rate, reach and stability of DSL Lines. The performance of neighbouring DSL lines should be measured to ensure that the change in the crosstalk due to energy management is not degrading nearby lines, which is considered to be DSM level 2 [21]. Further alterations in transmit PSDs may be necessary to ensure adequate crosstalk performance on nearby lines. The technique may be successively iterated to optimize multiple lines’ spectra for performance and energy usage.

Depending on cable conditions, service levels and the service quality needed for bitrate and stability; only minimal power savings may be attainable on some lines.

Since spectral optimization is also used by DSM level 2 techniques to improve performance, a trade-off between performance gains and energy efficiency gains has to be considered, since they cannot both be optimized in isolation.

6.5.3 Dynamic Line Management (DLM) Techniques

Dynamic Line Management involves changing per-line configuration in order to achieve the best possible trade-off between bit rate, error probability and stability. This includes for example modification of Impulse Noise Protection (INP) parameters and Signal-to-Noise Ratio margin (SNRM).

6.5.4 Automatic Margin Adaptation (AMA)

6.5.4.1 Objective – basic variant

AMA is a DSM level 1/DLM technique for the management of an unstable line by controlling the configured Noise Margin.

6.5.4.2 Target impairments

Incremental changes in crosstalk noise.

6.5.4.3 Involved DSL parameters and/or line characteristics

- Target SNR margin (TARSNRM)
- Minimum SNR margin (MINSNRM)
- Maximum SNR margin (MAXSNRM).

6.5.4.4 DQM technique method – basic variant

The TARSNRM is used during training of the modem and is the margin used to counter a future noise-increase, typically set to 6 dB. The DSL modems continue to measure and update the actual SNR margin of the link as the noise (and thus margin) changes. MINSNRM is a margin level (typically 0 dB) below which the DSL link will retrain. MAXSNRM is the maximum margin - above which the modems should reduce power.

Figure 13 shows this concept in the vertical axis line profile changes.

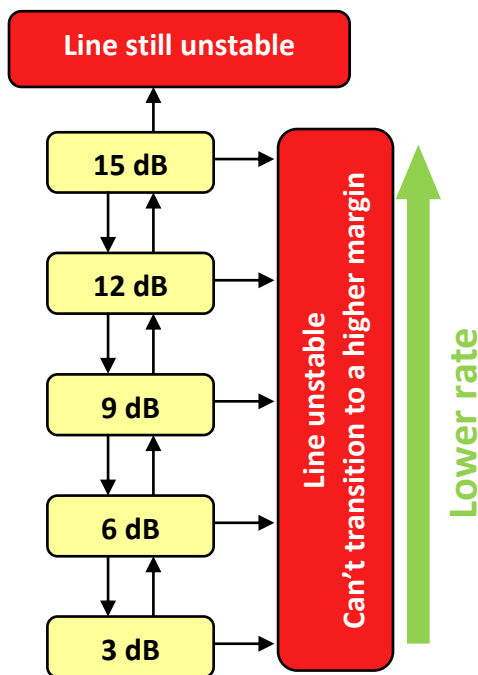

Figure 13: Example of target noise margin (TARSNRM) profiling schemes for AMA

The AMA techniques apply a set of profiles with different TARSNRM values. From the observation of the noise effects and history on the line (e.g. by the collection of historic PM register, of series of actual noise margin values, of series of SNR per subcarrier group values, etc) the Analysis and Diagnosis Function of the DQM system can identify the need to increase the TARSNRM to improve line stability or the BER or the opportunity to decrease it to improve the bitrate while still guaranteeing operation above certain quality and stability thresholds.

6.5.4.5 Caveats, trade-offs and limitations

Typically, retraining the DSL with higher margin to combat higher noise increases power and/or reduces data rate. However, margin levels are often not sufficiently high to offset large transient noises or intermittent/impulse noise. Furthermore, such large noise only occurs for a fraction of

the time. Thus, increasing the margin simply increases the power (and/or reduces the rate) all the time, while typically having little or no effect on a very intermittent noise. In these cases AMA is not power efficient.

Setting margin parameters adaptively is important in politeness, reducing transmitted power, emitted crosstalk, and also consumed power when intermittent noise is not present.

6.5.4.6 Related DQM techniques for escalated/combined strategies on the line

AMA techniques are usually combined with DLCM ones to tune also the protection to impulse noises.

6.5.4.7 Energy efficiency impacts

The noise margin can affect energy efficiency by changing the transmit power.

6.5.5 Tiered Rate Adaption (TRA)

6.5.5.1 Objective – basic variant

TRA is a DSM Level 1/DLM technique that manages an unstable DSL line limiting the data-rate range within which the modem is allowed to train among several (typically overlapping) ranges.

6.5.5.2 Target impairments

Incremental changes in crosstalk noise.

6.5.5.3 Involved DSL parameters and/or line characteristics

- Minimum data rate
- Maximum data rate.

6.5.5.4 DQM technique method – basic variant

Instead of directly controlling the noise margin, this technique places the line into one of a number of “speed bins” with different and potentially overlapping minimum and maximum speeds. Figure 14 shows this concept and the difference with a “normal” Rate Adaptive Profile.

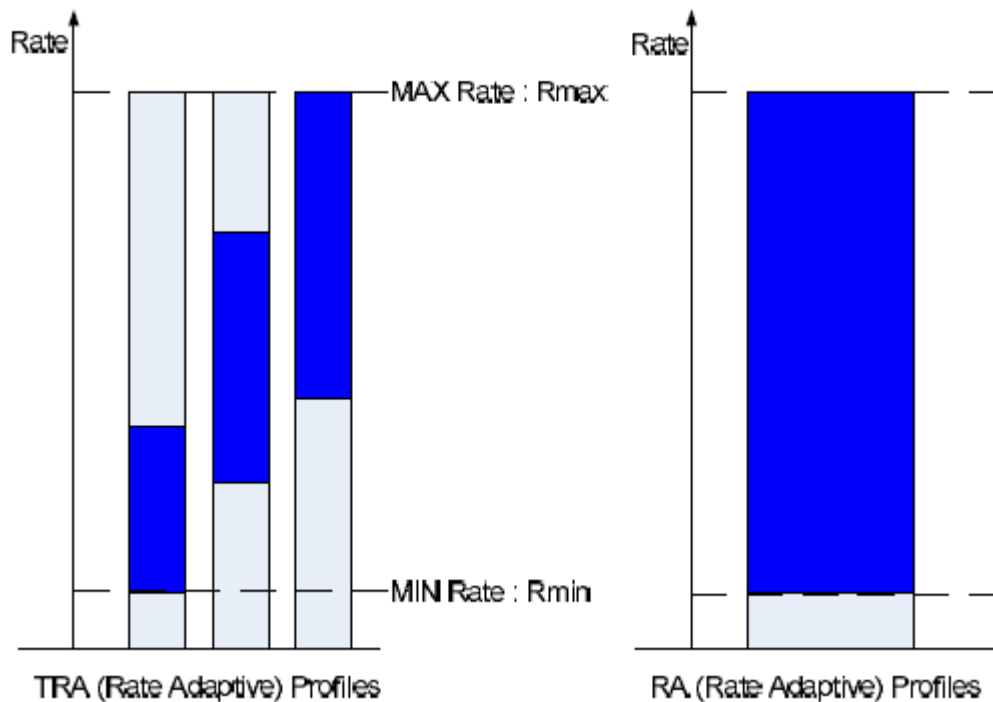

Figure 14: Comparison of Tiered Rate-Adaptive and Rate-Adaptive profiles

A minimum rate is also imposed (below which the DSL modems will retrain) such that a retrain during a very unlikely (but possible) large noise event will not cause the modem to stay at a very low data rate. Setting this minimum rate should be done with care to prevent taking a line out of service.

A line with very high margin and good stability is allowed by Tiered Rate Adaptation to increase speed. On the other hand, Tiered Rate Adaptation simultaneously handles two distinct cases of low margin or instability by lowering the range of target data rates below the current data rate:

1. A line operating at the maximum margin. When this line lowers its bit rate, it has a lower margin requirement and so the line will decrease its transmit power to avoid being above the maximum margin. This lowers the crosstalk into nearby lines enhancing system stability without improving the stability of the line..
2. A line operating below the maximum margin. When this line lowers its bit rate its margin increases, and the line becomes more stable. Crosstalk into nearby lines does not worsen since the transmit power is unchanged.

The TRA techniques can have the potential benefit of reducing overall crosstalk levels within the cable with subsequent positive impact on capacity and power consumption. Service providers need to assess the merits of different algorithmic approaches within their own network to assess the relative trade-offs in terms of capacity, stability and power consumption.

The TRA techniques apply a set of rate-adaptive profiles with different rate tiers. An initial Rate Adaptive (RA) tier is applied on the line based on a line qualification analysis or other information useful to determine a typical rate expected.

From the observation of line condition over time (e.g. by the collection of historic PM register, of series of actual noise margin values, of the attainable bitrate, etc.) the Analysis and Diagnosis Function of the DQM system can identify the need to configure a lower RA tier to improve line stability or the BER or the opportunity to configure a higher RA tier to improve the bitrate while still guaranteeing operation above certain quality and stability thresholds.

6.5.5.5 Caveats, trade-offs and limitations

As said above the choice of the number and span of the rate tiers in the applied profiles is based on the trade-offs in terms of capacity, stability and power consumption. Lines that are operating at their maximum noise margin will only improve stability if the maximum SNR margin parameter is increased at the same time as applying a lower rate tier.

6.5.5.6 Energy efficiency impacts

TRA can affect energy efficiency by changing the transmit power if the line is running at or near maximum margin.

7 Low Power States Techniques

7.1 Low-power transmission states techniques

7.1.1 Objective – basic variant

DSL lines transmit idle codes when there is no user traffic, and transmitting these idle codes is a waste of energy. The DSL line can be put in a low-power mode or low-power state when it needs to transmit little or no traffic. ADSL2 and ADSL2plus lines can transmit low data rates at low power (L2 link-state), or turn off of transmission (L3 link-state), at times when there is little or no traffic demand. L3 link-state can save more power than L2, however there appears to be no current equipment implementation of fast initialization, therefore exiting L3 requires a full retrain and so its use is often impractical. L2 link-state lowers the transmit power by up to 31 dB, and L2 link-state can be exited nearly instantaneously to full-power, full-speed, operation. VDSL2 does not currently have a specification for a low power (L2 link-state), but it can be turned off (L3 link-state).

Table 1 - Different DSL power states

L0	Full-power operation
L2	Low-power operation mode supporting low-rate data
L3	Nothing is transmitted

Different DSL power states are outlined in Table 1. A good description of how L2 link-state works is in Appendix A of TR-202 [16].

7.1.2 Target

The primary target is energy usage.

7.1.3 Involved parameters and/or line characteristics

Parameters for control of low-power mode are defined in ITU-T Recommendation G.997.1 from Section 7.3.1.1.3 to Section 7.3.1.1.9 and are applicable to ADSL2/2plus implementations:

- **Power Management State Forced (PMSF)**
This configuration parameter defines the line states to be forced by the near-end xTU on this line. It is coded as an integer value of 0, 2 or 3.
- **Power Management State Enabling (PMMode)**
This configuration parameter defines the line states the xTU-C or xTU-R may autonomously transition to on this line.
- **Minimum L0 time interval between L2 exit and next L2 entry (L0-TIME)**
This parameter represents the minimum time (in seconds) between an exit from the L2 state and the next entry into the L2 state.
- **Minimum L2 time interval between L2 entry and first L2 trim (L2-TIME)**
This parameter represents the minimum time (in seconds) between an entry into the L2 state and the first power trim in the L2 state and between two consecutive power trims in the L2 state.
- **Maximum aggregate transmit power reduction per L2 request or L2 power trim (L2 ATPR)..**
This parameter represents the maximum aggregate transmit power reduction (in dB) that can be performed in the L2 request (i.e. at transition from L0 to L2 state) or through a single power trim in the L2 state.
- **Total maximum aggregate transmit power reduction in L2 (L2-ATPRT)**
This parameter represents the total maximum aggregate transmit power reduction (in dB) that can be performed in an L2 state.

Additionally, performance can be monitored with the following parameters actual data rate, actual noise margin, ACTATP; as well as with the following error counters: CV-C, FECS-L, ES-L, SES-L, LOSS-L, and UAS-L.

7.1.4 DQM Technique methods – basic variants

Low-Power techniques are currently enabled on ADSL and ADSL2plus by entering L2 link-state when there is little traffic. The equipment can turn L2 link-state on and off, or a power management state transition can be forced by CO-MIB parameter PMSF. The following methods based upon existing standardized capabilities can be used to enhance stability of other lines by limiting the impact of time-varying crosstalk from this technique:

1. A simple Low-Power states technique which can improve stability somewhat is to very gradually transition into low-power states as specified in TR-202 [16], which may result in fewer transitions thus aiding the stability in victim lines. TR-202 recommends remaining in a given power state for at least 127 seconds ($L2\text{-TIME} \geq 127$ seconds and $L0\text{-TIME} \geq 127$ seconds), that each power reduction is at most 1 dB ($L2\text{-ATPR} = 1$ dB), and that the total power decrease by at most 10 dB ($L2\text{-ATPRT (dB)} \leq 10$). However, a line implementing this technique must leave the L2 link-state immediately to full-power to carry traffic, and so it still allows the major impact on victim lines to occur, although the frequency of occurrence is somewhat limited.
2. A DQM system can identify which lines can safely operate in low-power mode, and then only allow these lines to transition in and out of low-power mode. This is done by simultaneously monitoring performance of all nearby lines while a given line transitions in and out of low-power mode. For example, if the DQM system can tell that a line is not strongly coupled to neighbouring lines, then it can safely let it transition to low-power modes. If it is seen that there is high risk for causing damaging time-varying interference, the system can instruct the line not to transition to low-power modes, but instead it may use energy management methods for adjusting transmit power and spectrum. For cases in-between, the system can control intervals between power mode transitions and maximum power reductions, so that the impact on other lines is monitored and controlled . The standardized ADSL2/2plus low-power state configuration parameters are presented in the list in §7.1.3 of this document. DQM can manage which DSL lines are allowed to transition to and from low-power and high-power states via CO-MIB parameter PMMode, how frequently they can enter these states via CO-MIB parameters L0-TIME and L2-TIME, and maximum levels of power reduction via CO-MIB parameters L2-ATPR (per trim) and L2-ATPRT (total). Traffic levels can be determined by reading SNMP counters in IF-MIB [2], and low-power mode parameters can be adjusted according to traffic, for example setting L2-TIME to a high value with very low traffic.
3. The DQM system can categorize the level of impact caused by time-varying crosstalk from a line entering and exiting low power modes, according to other lines' loss of margin, re-syncs, error counts, seamless rate adaptation (SRA) to lower speeds, etc., into categories such as:
 - a) High impact. Do not allow these lines to enter and exit low-power states, or allow this only infrequently.
 - b) Low impact. Allow these non-impacting DSL lines to enter and exit low power states at will.
 - c) Middling impact. Intelligently select the intervals between entering L2 link-state for these lines, so that the impact on other lines is monitored and controlled . Also, the power reductions of transitions to L2 link-state can be controlled to ensure a gradual transition into L2-mode.

7.1.5 Caveats, trade-offs and limitations

Low Power mode is currently specified only for ADSL2 and ADSL2plus, not for VDSL2 at this time.

Interoperability is not mature in some cases, thus introducing another limitation in its use in the network. Furthermore the current ITU-T specification does not contemplate that the channel information is updated between the modems while in L2 state. Worsening of channel conditions may result in instability when the modems transition from L2 back to the original L0 conditions.

When low power mode is utilised on a line that is configured for interleaving, the delay is not constrained so that when the line switches into low power mode, the configured maximum interleaving delay can be significantly exceeded.

An important issue when using low-power states is instability in other lines in the cable/binder caused by time-varying crosstalk (sometimes called non-stationary or short-term stationary crosstalk). Assume that DSL line #1 is alternately transmitting at high-power and at low-power, and is creating significant crosstalk into a nearby DSL line #2. If DSL line #2 starts-up while DSL line 1 is transmitting low-power, then when DSL line #1 later transitions to transmitting high-power it can create a large increase in crosstalk noise into DSL line #2, possibly causing DSL line #2 to re-train or be unstable. Partly because of this stability problem, low power states are rarely used in current DSL deployments.

The use of time-varying low-power modes presents management difficulties. Varying the transmit signal can result in time-varying crosstalk that may disrupt nearby lines. Techniques presented here can minimize this disruption; but only with careful application. Adapting DSL line states according to traffic resource assignments could involve interactions with higher layers, and these are generally undefined for DSL equipment.

Note: In unbundled environments, DQM may not be able to monitor all lines and so some techniques presented here for ensuring stability while using L2 link-state may not apply.

Always connected DSL lines with discontinuous traffic can obtain a good reduction of line transmit power with this technique. However it is not simple to evaluate the energy savings, since the relationship between transmit power and equipment energy consumption is not currently available.

Some counter-measures to avoid instability (e.g. higher SNR margin, use of VN) could lead to higher power consumption when the lines are active, decreasing the obtainable energy efficiency.

7.1.6 Related DQM techniques for escalated/combined strategies on the line

SRA and SOS techniques could be used to reduce the risk of a re-initialization of other lines when a line in L2 state suddenly wakes up.

Another proposed Energy Management technique to improve stability due to the effects on lines in a cable/binder entering L2 link-states, is to increase the noise margin or use virtual noise (which also increases the noise margin, but only selectively at some frequencies) on potential victim lines. This is supposed to enhance stability in the face of time-varying crosstalk. However, lines implementing this technique are forced to transmit at a higher power, generally negating power savings and rendering the technique ineffective overall for energy management [22]. Additionally, use of this technique increases the level of stationary crosstalk in the cable degrading the bit rate of all lines in the cable/binder.

Vectoring can also minimize crosstalk between lines, but only for the lines in the vectored group. As said above a Low Power Mode is not specified for VDSL2 hence its use with Vectoring is not yet possible.

A. Appendix A - Transmit power savings relation to overall energy savings

This Appendix provides considerations on the relationship between transmit power reduction and the overall consumption at the equipment power mains.

MR-204 [17] describes global relationships of broadband and energy efficiency. MR-204 says that decreasing power usage of telco equipment by 1.0 W results in an overall power savings of 2.41 W. This is because equipment power use is accompanied by power use for DC power conversion, power distribution, cooling, etc.

References [B.1]-[B.8] present information, in some detail, on DSL energy efficiency, including optimization of transmit spectra both for performance and for energy consumption, as well as optimal use of DSL low-power states.

[A.1] Considerations for ADSL2/2plus

Along with the trade-off between energy consumption, delay, performance (bit-rate and stability); the actual reduction of the consumption at the power mains of DSL equipment (DSLAMs, MSANs, ONUs, CPEs, Residential Gateways) is not typically available through remote diagnostics. The exact relationship between transmit power and mains power usage varies considerably from product to product and depends on the operational conditions. However, this relationship can be measured with a power meter in a lab.

Lowering the transmit power results in a reduction of total mains power usage, and this reduction varies with equipment type. Some field trial results found that modest reductions of transmit power can save about 230 mW per line with newer DSLAMs and modems, but generally less with older DSLAMs and modems. This power reduction was obtained with no loss in overall performance due to the use of re-profiling.

A recent paper explored the relationship between transmit power and line driver power consumption [B.9] This showed that reducing ADSL2plus transmit power by 10 dB from the maximum transmit power saves about 400 mW. Reference [B.11] stated that the line driver accounts for close to 50% of an ADSL2 DSLAM's energy consumption. Reference [B.10] noted that up to 85% reduction in power use by some line drivers is possible by transmit power reduction; so up to 40% energy savings is possible by lowering transmit power.

Reference [B.10] presented simulation results under various traffic settings and DSL scenarios demonstrating energy savings by use of ADSL2 low-power states of around 30–40% of the ADSL2 transceiver's power consumption. A study [B.11] estimated that in 2015-2020, usage of home broadband access (user up time) will be about 30%, and link utilization when a user is connected will be about 10%, and the remaining time could use low power states. Reference [B.12] presents a forecast of network power consumption.

[A.2] Considerations for VDSL2

Lowering the transmit power results in a reduction of total mains power usage, and this reduction varies with equipment type. Lab measurements were performed by Telecom Italia to explore the relationship between transmit power and line driver power consumption. A GPON-fed ONU with 48 VDSL2 ports was configured with this line configuration:

- rate adaptive with maximum bitrate set to 100 Mbit/s
- min-target-max NM: 1-6-31 dB
- INP-Delay: 2 symb – 8 ms
- DS MaxNomATP of: 14.5 dBm (max ATP), 12dBm, 9dBm, 6dBm.
- US MaxNomATP: max ATP

Lines were synchronized with the maxATP profile and the mains power consumption was recorded. After that, some lines were reprofiled with a lower ATP profile and resynchronized to measure again the power consumption. Measurement results are in Table 2.

Table 2. The measured power consumption over the 8 test lines.

	Average DS TxPwr (dBm)	Total Power Consumption (W)	Apportion Transceiver Consumption per line (W)	Apportion Common parts Consumption per line (W)	Total (W)	% savings
All lines disabled		33.69	N/A	0.70	-	-
Full ATP on 8 lines	14.50	40.97	0.91	0.70	1.61	-
ATP 12dBm on 8 lines	11.91	40.31	0.83	0.70	1.53	5.12%
ATP 9dBm on 8 lines	8.90	39.73	0.76	0.70	1.46	9.62%
ATP 6dBm on 8 lines	5.90	39.35	0.71	0.70	1.41	12.56%

These measurements showed that reducing VDSL2 transmit power by 8.5 dB from the maximum transmit power saves about 200 mW per line. It was also noted that the DSL transceiver (line driver + AFE + Digital data pump) accounts for nearly 60% of the measured VDSL2 ONU's energy consumption, and that the mentioned 200mW account for about 20% reduction in DSL transceiver power use.

When including the common part of the power consumption, which is independent of the DSL transmit power; an extrapolation to relate these measurements to overall power consumption is shown in Table 3. This shows that the total power used by the ONU would decrease by about 6% if half of the lines (24 out of 48) lowered their transmit power by 8.5 dB from 14.5 dBm to 6 dBm. The above numbers assume a fully equipped equipment while in the real network not all the installed ports are active.

The extrapolated results are in the following table:

Table 3. Extrapolated total equipment power consumption in different situations.

ATP of reprofiled lines	all 48 lines reprofiled		24 lines reprofiled 24 lines with full ATP		16 lines reprofiled 32 lines with full ATP		8 lines reprofiled 40 lines with full ATP	
	Power consumption Watts	% savings	Power consumption Watts	% savings	Power consumption Watts	% savings	Power consumption Watts	% savings
Full ATP	77.37	---	77.37	---	77.37	---	77.37	---
ATP 12dBm	73.41	5.12%	75.39	2.56%	76.05	1.71%	76.71	0.85%
ATP 9dBm	69.93	9.62%	73.65	4.81%	74.89	3.21%	76.13	1.60%
ATP 6dBm	67.65	12.56%	72.51	6.28%	74.13	4.19%	75.75	2.09%

B. Informative References

- [B.1] J. M. Cioffi, S. Jagannathan, W. Lee, H. Zou, A. Chowdhery, W. Rhee, G. Ginis, P. Silverman, “Greener Copper with Dynamic Spectrum Management”, in AccessNets, Las Vegas, NV, USA, October 2008.
- [B.2] M. Wolkerstorfer, D. Statovci, and T. Nordstrom, “Dynamic spectrum management for energy-efficient transmission in DSL”, in Proceedings of the 11th IEEE International Conference on Communication System, 2008, pp. 1015-1020.
- [B.3] P. Tsiaflakis, Y. Yi, M. Chiang, and M. Moonen, “Green DSL: Energy efficient DSM”, in Proc. of IEEE Internat. Conf. on Communications (ICC 2009), Dresden, Germany, June 2009.
- [B.4] P. Tsiaflakis, Y. Yi, M. Chiang, and M. Moonen, “Fair greening for DSL broadband access”, in ACM Sigmetrics/Performance GreenMetrics Workshop, Seattle, WA, USA, June 2009.
- [B.5] T. Nordstrom, M. Wolkerstorfer, and D. Statovci, “Energy efficient power backoff management for VDSL2 transmission”, in Proceedings of the European Signal Processing Conference (EUSIPCO), Glasgow, Aug. 2009, pp. 2097-2101.
- [B.6] M. Monteiro, N. Lindqvist, and A. Klautau, “Spectrum balancing algorithms for power minimization in DSL networks”. in Proceedings of the IEEE International of the IEEE International Conference on Communication, Dresden, Jun. 2009, pp. 15.
- [B.7] I. Kamitsos, P. Tsiaflakis, S. Ha, and M. Chiang, “Stable Sleeping in DSL Broadband Access: Feasibility and Tradeoffs”, in Proc. IEEE Globecom, Houston, TX, December 2011.
- [B.8] I. Kamitsos, P. Tsiaflakis, K. Kerpez, S. Ha, and M. Chiang, “Energy Efficient DSL via Heterogeneous Sleeping States: Optimization Structures and Operation Guidelines”, in Proc. IEEE Globecom 2012.
- [B.9] M. Wolkerstorfer, S. Trautmann, T. Nordstrom and B.D. Putra, "Modeling and optimization of the line-driver power consumption in xDSL systems", in EURASIP Journal on Advances in Signal Processing 2012, 2012:226.
- [B.10] M. Wolkerstorfer, D. Statovci, and T. Nordstrom, “Energy-saving by low-power modes in ADSL2”, Computer Networks, vol. 56, no. 10, pp 2468-2480, July 2012.
- [B.11] K. Hooghe, M. Guenach, “Toward Green Copper Broadband Access Networks,” IEEE Communications Magazine 49 (8), August 2011, pp. 87–93.
- [B.12] R. Bolla, F. Davoli, R. Bruschi, K. Christensen, F. Cucchietti, S. Singh, “The Potential Impact of Green Technologies in Next-Generation Wireline networks: Is There Room for Energy Saving Optimization?, IEEE Communications Magazine 49 (8), August 2011, pp. 80–86.

End of Broadband Forum Technical Report TR-197