

TP-247

G-PON & XG-PON & XGS-PON ONU Conformance Test Plan

Issue: 4
Issue Date: April 2020

Notice

The Broadband Forum is a non-profit corporation organized to create guidelines for broadband network system development and deployment. This Test Plan is owned and copyrighted by the Broadband Forum, and portions of this Test Plan may be owned and/or copyrighted by Broadband Forum members.

Intellectual Property

Recipients of this document are requested to submit, with their comments, notification of any relevant patent claims or other intellectual property rights of which they may be aware that might be infringed by any implementation of this Test Plan, and to provide supporting documentation.

Terms of Use

Recipients of this document may use it (a) for internal review and study purposes, (b) to provide to the Broadband Forum the comments and notification requested in the preceding paragraph, and (c) if the Recipient is a Broadband Forum member, to implement the Test Plan in a product or service made commercially available. Any other use of this Test Plan is expressly prohibited without the prior written consent of the Broadband Forum.

THIS TEST PLAN IS BEING OFFERED WITHOUT ANY WARRANTY WHATSOEVER, AND IN PARTICULAR, ANY WARRANTY OF NONINFRINGEMENT AND ANY IMPLIED WARRANTIES ARE EXPRESSLY DISCLAIMED. ANY USE OF THIS TEST PLAN SHALL BE MADE ENTIRELY AT THE USER'S OR IMPLEMENTER'S OWN RISK, AND NEITHER THE FORUM, NOR ANY OF ITS MEMBERS OR SUBMITTERS, SHALL HAVE ANY LIABILITY WHATSOEVER TO ANY USER, IMPLEMENTER OR THIRD PARTY FOR ANY DAMAGES OF ANY NATURE WHATSOEVER, DIRECTLY OR INDIRECTLY, ARISING FROM THE USE OF THIS TEST PLAN, INCLUDING BUT NOT LIMITED TO, ANY CONSEQUENTIAL, SPECIAL, PUNITIVE, INCIDENTAL AND INDIRECT DAMAGES.

All copies of this Test Plan (or any portion hereof) must include the notices, legends and other provisions set forth on this page.

© 2020, The Broadband Forum. All rights reserved. This Broadband Forum document (TP-247) specifies the Test Plan on which is based the BBF.247 Certification Program for G-PON & XG-PON & XGS-PON ONU products. Through an open selection process, the Broadband Forum entered into an agreement with one or more independent Test Agencies to offer commercial testing services against this Test Plan and to confirm results to the Broadband Forum in connection with the Forum's delivery of BBF.247 Certification. Offering Certification testing services against this Test Plan is reserved to the Test Agencies duly authorized by the Broadband Forum. Broadband Forum members can independently test against TP-247, but may only produce limited reports which only detail where a given product has failed a test case

NOTE: The right to display a Broadband Forum Certification Logo may only be granted by the Broadband Forum, and that right is available only to Broadband Forum members that have successfully passed certification testing by a duly authorized Test Agency. Further details on the Broadband Forum Certification Programs can be found at <http://www.broadband-forum.org>

Issue History

Issue Number	Approval Date	Publication Date	Issue Editor	Changes
1	October 2011		Michael Shaffer, Alcatel-Lucent	Original
2	January 2013	11 February 2013	Michael Shaffer, Alcatel-Lucent Lincoln Lavoie, UNH InterOperability Lab Yuan Liquan, ZTE	ONU profiles, Support of ONU/RG
3	May 2014	16 May 2014	Michael Shaffer, Alcatel-Lucent Lincoln Lavoie, UNH InterOperability Lab Yuan Liquan, ZTE Vincent Buchoux, LAN	Support of XG-PON1 Support of SFP/ONU & PON fed VDSL2 ONU
3 Amendment 1	6 July 2016	13 July 2016	Vincent Buchoux Gilles Samson Laboratoire des Applications Numériques (LAN)	Support of Multi-managed ONU with PPTP Ethernet UNI ME implementation Clarification of test coverage for Multi-managed ONU
3 Amendment 2	4 June 2018	9 July 2018	Vincent Buchoux Gilles Samson Laboratoire des Applications Numériques (LAN)	Support and inclusion added for TR-301 Model 2 Gfast DPU/ONU
4	17 April 2020	17 April 2020	Vincent Buchoux Laboratoire des Applications Numériques (LAN)	Legal Notices for BBF Test Plan included IR-247 issue 3 amendments 1 & 2 included in issue 4 New OLT Emulator Requirements from TR-156 issue 4 XGS-PON support New ONU Profiles defined <ul style="list-style-type: none"> Profile E – Enhanced Operations Profile F – Enhanced Multicast Operations Profile G – Capacity Test Cases Profile H – Monitoring Test Cases Profile I – Extended OMCI Messages Format Test Cases Support of new TR-280 functionalities (TR-280 & TR-280 Issue 1 Amd1) <ul style="list-style-type: none"> Extended OMCI Messages Format Multicast Channel White List

Issue Number	Approval Date	Publication Date	Issue Editor	Changes
				Traffic Class addition and deletion Monitoring Support of additional features from TR-156 VLANs and GEM Ports / Ethernet Frame forwarding QoS / Traffic Management New Section 4.3 OMCI Messages & related subsections New Section 6.12 TR-280 Other New Section 6.13 Counters Annex B:OMCI Procedure Details made obsolete

Comments or questions about this Broadband Forum Test Plan should be directed to info@broadband-forum.org.

Editor	Vincent Buchoux	Laboratoire des Applications Numériques - LAN
Work Area Director	Marta Seda	CALIX
	Samuel Chen	BROADCOM

Table of Contents

Executive Summary	12
1 Purpose and Scope	13
1.1 Purpose.....	13
1.2 Scope.....	13
2 References and Terminology	14
2.1 Conventions.....	14
2.2 References.....	14
2.3 Definitions.....	16
2.4 Abbreviations.....	18
3 Test Plan Impact	21
3.1 Energy Efficiency.....	21
3.2 Security.....	21
3.3 Privacy.....	21
4 Test Methodology	22
4.1 Standards Conformance Testing.....	22
4.2 ONU Testing Requirements.....	22
4.2.1 <i>ONU Clean-slate Requirements</i>	22
4.2.2 <i>ONU/L2</i>	23
4.2.3 <i>Multi-managed ONU</i>	31
4.3 OMCI Messages.....	37
4.3.1 <i>Reference OMCI Message Sequences</i>	37
4.3.2 <i>OMCI Scrambling process</i>	37
4.3.3 <i>Extended OMCI Format</i>	38
4.3.4 <i>OMCI version & Profiles Applicability</i>	38
4.4 Test Setup.....	39
4.4.1 <i>OLT Emulator Requirements</i>	39
4.4.2 <i>G-PON Analyzer Requirements</i>	41
4.4.3 <i>Optical Distribution Network Requirements</i>	41
4.4.4 <i>Unit under Test Management Interface Requirements</i>	41
4.4.5 <i>Selection of Random Values Used in Test Cases</i>	41
4.4.6 <i>ONU Conformance Test Setup</i>	42
5 Test Case Summary	44

6	ONU Conformance Tests	44
6.1	Classification and Tagging	45
6.1.1	Single untagged U-interface	45
6.1.2	Single U-interface with symmetric VLAN tag translation	48
6.1.3	Deriving P-bits as a function of received P-bits (single user port)	51
6.1.4	Addition of an S-Tag in the Upstream Direction in a VBES Architecture	53
6.1.5	Validation of an S-Tag in the Upstream Direction in a VBES Architecture	55
6.1.6	Translation of an S-Tag in the Upstream Direction in a VBES Architecture	57
6.1.7	Removal of an S-Tag in the Downstream Direction in a VBES Architecture	60
6.1.8	Translation of an S-Tag in the Downstream Direction in a VBES Architecture	62
6.1.9	Test Case Reserved For Future Use	64
6.1.10	Deriving P-bits as a function of received VID (single user port)	65
6.1.11	Deriving P-bits as a function of received Ethertype (single user port)	67
6.1.12	Deriving P-bits as a function of received user port	69
6.1.13	VID Support for Untagged Frames (N:1 VLAN or 1:1 VLAN Architecture Single-Tagged at the V Interface)	71
6.1.14	VID Support for Untagged Frames (1:1 VLAN Architecture Double-Tagged at the V Interface)	74
6.1.15	VID Support for Priority Tagged Frames with Priority Preservation (N:1 VLAN or 1:1 VLAN Architecture Single-Tagged at the V Interface)	77
6.1.16	VID Support for Priority Tagged Frames without Priority Preservation (N:1 VLAN or 1:1 VLAN Architecture Single-Tagged at the V Interface)	79
6.1.17	VID Support for Priority Tagged Frames with Priority Preservation (1:1 VLAN Architecture Double-Tagged at the V Interface)	81
6.1.18	VID Support for Priority Tagged Frames without Priority Preservation (1:1 VLAN Architecture Double-Tagged at the V Interface)	84
6.1.19	ONU addition and removal of C-Tag for 1:1 VLANs	87
6.1.20	ONU addition and removal of S-Tag for 1:1 VLANs	90
6.1.21	ONU translation between Q-Tag and C-Tag for 1:1 VLANs	93
6.1.22	ONU translation between Q-Tag and S-Tag for 1:1 VLANs	96
6.1.23	Test case reserved for future use	99
6.1.24	Deriving P-bits as a function of received P-bits for a VBES architecture (single user port)	100
6.1.25	Deriving P-bits as a function of received VID for a 1:1 or N:1 architecture (single user port)	102
6.1.26	Deriving P-bits as a function of received Ethertype for a 1:1 or N:1 architecture (single user port)	104
6.1.27	Deriving P-bits as a function of received user port for a 1:1 or N:1 architecture	106
6.1.28	Support of 67 Entries on extended VLAN tagging operation table and 8 VLANs	108
6.1.29	Verifying MAC Address is not used as a Classification Criterion	114
6.1.30	Downstream Translation for Code Point 0	117
6.1.31	Downstream Translation for Code Point 1	120
6.1.32	Downstream Translation for Code Point 2	123
6.1.33	Downstream Translation for Code Point 3	126
6.1.34	Downstream Translation for Code Point 4	129
6.1.35	Downstream Translation for Code Point 5	132
6.1.36	Downstream Translation for Code Point 6	135
6.1.37	Downstream Translation for Code Point 7	138

6.1.38	<i>Downstream Translation for Code Point 8</i>	141
6.2	<i>Frame Mapping and QoS</i>	144
6.2.1	<i>Single U-interface with multiple downstream GEM ports</i>	144
6.2.2	<i>User Isolation on ONU Devices with Multiple U-interfaces</i>	147
6.2.3	<i>Mapping Traffic from GEM Ports to U Interface in the Downstream Direction in a VBES Architecture</i>	149
6.2.4	<i>Mapping traffic into GEM Ports based on P-bit values in the upstream direction (single user port)</i>	151
6.2.5	<i>Mapping traffic into GEM Ports based on VID values in the upstream direction (single user port)</i>	153
6.2.6	<i>Mapping traffic into GEM Ports based on VID & P-bit values in the upstream direction (single user port)</i>	155
6.2.7	<i>Mapping traffic into GEM Ports based on P-bit values in the upstream direction (multiple user port)</i>	157
6.2.8	<i>Mapping traffic into GEM Ports based on VID values in the upstream direction (multiple user port)</i>	159
6.2.9	<i>Mapping traffic into GEM Ports based on VID & P-bit values in the upstream direction (multiple user port)</i>	161
6.2.10	<i>Mapping multiple P-bit values to the same GEM port (single user port)</i>	163
6.2.11	<i>Test Case Reserved For Future Use</i>	165
6.2.12	<i>Strict priority downstream scheduling among 4 queues on ONU</i>	166
6.2.13	<i>Indicating drop precedence using P-bits upstream</i>	169
6.2.14	<i>Indicating drop precedence using DEI bit upstream</i>	171
6.2.15	<i>Indicating drop precedence using P-bits downstream</i>	173
6.2.16	<i>Indicating drop precedence using DEI bit downstream</i>	175
6.2.17	<i>Test Case Reserved For Future Use</i>	177
6.2.18	<i>Test Case Reserved For Future Use</i>	177
6.2.19	<i>Mapping Traffic from GEM Ports to Multiple U Interfaces in the Downstream Direction</i>	178
6.2.20	<i>Test Case Reserved For Future Use</i>	180
6.2.21	<i>Mapping Traffic from GEM Ports to Multiple U Interfaces in the Downstream Direction</i>	181
6.2.22	<i>Test Case Reserved For Future Use</i>	184
6.2.23	<i>Test Case Reserved For Future Use</i>	184
6.2.24	<i>Test Case Reserved For Future Use</i>	184
6.2.25	<i>Strict Priority Downstream Scheduling Among 2 Queues on ONU with Unicast and Multicast Traffic</i>	185
6.3	<i>IGMP Controlled Multicast</i>	190
6.3.1	<i>ONU passing of downstream IGMP messages</i>	190
6.3.2	<i>Test Case Reserved For Future Use</i>	193
6.3.3	<i>ONU silent discarding of IGMPv1 messages</i>	194
6.3.4	<i>Test Case Reserved For Future Use</i>	196
6.3.5	<i>Marking Upstream IGMP Messages with Ethernet P-Bits</i>	197
6.3.6	<i>IGMP controlled Multicast</i>	199
6.3.7	<i>Multicast White List</i>	203
6.3.8	<i>IGMP rate limit</i>	206
6.3.9	<i>IGMP immediate leave</i>	208
6.3.10	<i>Maximum number of multicast flows</i>	211
6.3.11	<i>IGMP transparent Snooping</i>	214
6.3.12	<i>Multicast VLAN membership based on user ports (Multiple User ports)</i>	217

6.3.13	<i>IGMP transparent Snooping (Multiple User ports)</i>	220
6.3.14	<i>IGMP Transparent forwarding</i>	223
6.3.15	<i>Maximum Multicast Bandwidth</i>	225
6.3.16	<i>VID and P-bit Translation in Upstream and Downstream for IGMP/MLD and Multicast Packets</i>	229
6.3.17	<i>Create and Remove Multicast Groups in the Dynamic Access Control List table</i>	234
6.3.18	<i>Maximum Number of Dynamic Multicast Groups Modification</i>	238
6.3.19	<i>Maximum Multicast Bandwidth Modification</i>	242
6.3.20	<i>Individual multicast groups in Dynamic Access Control List table</i>	246
6.3.21	<i>Whole Multicast Range in Dynamic Access Control List table</i>	250
6.4	<i>Non-IGMP Controlled Multicast and Broadcast</i>	254
6.4.1	<i>Downstream Broadcast Handling, Single U-interface</i>	254
6.4.2	<i>Downstream Broadcast Handling, Multiple U-interfaces</i>	256
6.5	<i>Filtering</i>	258
6.5.1	<i>Test Case Reserved For Future Use</i>	258
6.5.2	<i>Test Case Reserved For Future Use</i>	258
6.5.3	<i>Test Case Reserved For Future Use</i>	258
6.5.4	<i>Test Case Reserved For Future Use</i>	258
6.5.5	<i>Test Case Reserved For Future Use</i>	258
6.5.6	<i>Test Case Reserved For Future Use</i>	258
6.5.7	<i>Test Case Reserved For Future Use</i>	258
6.5.8	<i>Test Case Reserved For Future Use</i>	258
6.5.9	<i>Test Case Reserved For Future Use</i>	258
6.6	<i>TR-156 Other</i>	259
6.6.1	<i>2000-Byte Frames Supported by the ONU</i>	259
6.6.2	<i>Test Case Reserved For Future Use</i>	262
6.7	<i>Initial provisioning of ONU</i>	263
6.7.1	<i>Local setting of a registration ID at the ONU (ONU retains the Registration ID indefinitely)</i>	263
6.8	<i>ONU Bring-up</i>	265
6.8.1	<i>New ONU Bring-up method for new ONU</i>	265
6.8.2	<i>New ONU Bring-up method for old ONU</i>	267
6.8.3	<i>Old ONU Bring-up method for ONU</i>	269
6.8.4	<i>New ONU Bring-up method for new ONU with encrypted OMCC</i>	271
6.8.5	<i>OMCI Version During New ONU Bring Up</i>	273
6.9	<i>MIB and Alarm Synchronization</i>	275
6.9.1	<i>Alarm synchronization</i>	275
6.9.2	<i>MIB synchronization: Correct Data Sync</i>	277
6.9.3	<i>MIB synchronization: MIB Upload</i>	279
6.9.4	<i>U interface status reporting and alarms</i>	281
6.9.5	<i>Optical parameters counters and alarms</i>	284
6.9.6	<i>OMCI reboot with OMCI configuration persistence</i>	288

6.9.7	OMCI reboot without OMCI configuration persistence	291
6.9.8	OMCI Reset & MIB synchronization	294
6.9.9	Use of Extended OMCI in a MIB Upload Using the Minimal Data Allocation Size.....	297
6.9.10	Use of Extended OMCI in a MIB Upload with Maximum Upstream Bandwidth.....	299
6.10	Software Image Download	301
6.10.1	Software Image Download, multiple window sizes, padded final window	301
6.10.2	Software Image Download, shortened final window.....	304
6.10.3	Failed Software Image Download, missing section.....	307
6.10.4	Failed Software Image Download, incorrect section CRC.....	309
6.10.5	Failed Software Image Download, incorrect software image CRC	311
6.10.6	Test Case Reserved For Future Use.....	314
6.10.7	Activate uncommitted software image.....	315
6.10.8	Commit software image	317
6.10.9	Use of Extended OMCI in a Software Download with the Minimal and Variable Section Size.....	319
6.10.10	Use of Extended OMCI in a Software Download using the OMCI Maximum Message Size	322
6.10.11	Use of Extended OMCI in a Software Download with a 33 bytes OMCI payload size	325
6.11	Circuit Packs.....	328
6.11.1	Test Case Reserved For Future Use.....	328
6.11.2	Test Case Reserved For Future Use.....	328
6.11.3	Cardholder or port mapping package for integrated ONU.....	329
6.11.4	Test Case Reserved For Future Use.....	331
6.11.5	Test Case Reserved For Future Use.....	331
6.11.6	Test Case Reserved For Future Use.....	331
6.12	TR-280 Other.....	332
6.12.1	Dying Gasp Emission.....	332
6.12.2	Create and Modify Configuration.....	334
6.12.3	Unicast GEM port encryption in the downstream direction.....	338
6.12.4	GEM port Encryption in the Upstream Direction	341
6.12.5	ONU Remote Debug.....	344
6.12.6	Create, Delete and Add New Services	346
6.12.7	Create, Delete and Add New Services in Strict Priority Downstream Scheduling Context	350
6.13	Counters	355
6.13.1	Performance Monitoring on Ethernet Frames.....	355
6.13.2	Performance Monitoring on Multicast Ethernet Frames	362
Annex A:	Test Case Template	370
Annex B:	OMCI Procedure Details (obsolete).....	372
Annex C:	OMCI Scrambler Principle of Operation	373

Annex D: OMCI Scrambler Example Implementation.....374

List of Figures

Figure 1 – Network architecture for Ethernet-based G-PON aggregation (TR-167 issue 2 [21]) 34
 Figure 2 - Basic test setup for ONU conformance testing42
 Figure 3 – Basic test setup for multiple subscriber ONU.....43

List of Tables

Table 4-1: Profile A – N:1 VLAN Architecture23
 Table 4-2: Profile B – 1:1 VLAN Architecture.....24
 Table 4-3: Profile C – VBES VLAN Architecture25
 Table 4-4: Profile D – Multicast Operations25
 Table 4-5: Profile E – Enhanced Operations26
 Table 4-6: Profile F – Enhanced Multicast Operations27
 Table 4-7: Profile G – Capacity Test Cases.....28
 Table 4-8: Profile H – Monitoring Test Cases28
 Table 4-9: Profile I – Extended OMCI Messages Format Test Cases29
 Table 4-10: Baseline Test Cases29

Executive Summary

In order to create a process for the ongoing promotion of G-PON interoperability, Broadband Forum has embarked on a G-PON certification program. The core feature of this program is the verification of G-PON ONU adherence to the relevant BBF and ITU-T technical specifications by accredited testing agencies. To provide a consistent scope for this verification, BBF developed test plans that are to be used by the testing agencies in the verification process.

TP-247 provides a test plan that may be used to verify conformance of a G-PON / XG-PON / XGS-PON ONU to the requirements defined in TR-156 [18][19][20] and TR-280 [23][24]. Additionally, this test plan verifies that the OMCI implementation contained in a G-PON / XG-PON / XGS-PON ONU adheres to the practices described in Appendix I and II of G.988 [6][7][8].

Updates for Issue 4 include:

- Inclusion of the IR-247 Issue 3 Amendment 1 [14]
 - making explicit Test Case 6.9.1 Alarm synchronization is Not Applicable to multi-managed ONUs
 - adding the support of PPTP Ethernet UNI ME as an alternative to the VEIP ME for the conformance verification of multi-managed ONUs as per TR-280 requirement R-68 [23]
- Inclusion of the IR-247 Issue 3 Amendment 2 [15]
 - adding the support of ONU type “TR-301 Model 2 Gfast DPU/ONU (TR-156 Backhaul)” within the BBF.247 certification program
- Addition of the support of XGS-PON ONUs
- Addition of the support of several advanced & enhanced functionalities based on TR-280 requirements [23][24] among which
 - Enhanced QoS
 - Enhanced Multicast
 - Alarms and counters
 - Filtering and Learning
 - Extended OMCI Format Message support
- Addition of the support of new profiles
 - Enhanced Operations
 - Enhanced Multicast Operations
 - Capacity Test Cases
 - Monitoring Test Cases
 - Extended OMCI Message Format Test Cases
- Addition of the support of several additional functional features based on TR-156 requirements [18][19][20]
 - VLANs and GEM Ports / Ethernet Frame forwarding determination
 - QoS / Traffic Management Requirements

1 Purpose and Scope

1.1 Purpose

This test plan describes a series of tests that may be used to verify whether particular ONU implementations conform to TR-156 [18][19][20], TR-280 [23][24] and functional requirements, and that the related configuration recommendations from the OMCI Implementer's Guide have been implemented [6][7][8].

1.2 Scope

The tests cases defined in TP-247 are dedicated to testing standards conformance. This includes a limited set of key test cases that can verify the conformance of G-PON ONU to a defined set of Broadband Forum TR-156 [18][19][20], TR-280 [23][24] requirements, and the related recommendations from Appendix I and II of G.988 [6][7][8].

These test cases include verification of conformance regarding both the required G-PON [2][3] / XG-PON [4][5] / XGS-PON [10] equipment functionality, and the implementation of the OMCI protocol by that equipment. TP-247 is designed to verify the particular functions of G-PON / XG-PON / XGS-PON implementations that are the most critical to real-world service providers' deployments.

Testing of system level performance of G-PON equipment is for further study and not yet addressed in the current scope.

XG-PON ONUs compliant with the ITU-T G.987 series of specifications [4][5] may be tested using the test cases defined here to verify their compliance with TR-156 [18][19][20], TR-280 [23][24] and G.988 [6][7][8].

XGS-PON ONUs compliant with the ITU-T G.9807 series of specifications [10] may be tested using the test cases defined here to verify their compliance with TR-156 [18][19][20], TR-280 [23][24] and G.988 [6][7][8].

Note: The remainder of this document uses the term G-PON in a generic manner to refer to any ITU-T TDM PON including G-PON, XG-PON and XGS-PON. In the same way, the term GEM port refers to GEM port and XGEM port, and GTC refers to GTC and XGTC, PLOAM to PLOAM and XPLOAM.

2 References and Terminology

2.1 Conventions

In this Test Plan, several words are used to signify the requirements of the specification. These words are always capitalized. More information can be found in RFC 2119 [12].

MUST	This word, or the term “REQUIRED”, means that the definition is an absolute requirement of the specification.
MUST NOT	This phrase means that the definition is an absolute prohibition of the specification.
SHOULD	This word, or the term “RECOMMENDED”, means that there could exist valid reasons in particular circumstances to ignore this item, but the full implications need to be understood and carefully weighed before choosing a different course.
SHOULD NOT	This phrase, or the phrase "NOT RECOMMENDED" means that there could exist valid reasons in particular circumstances when the particular behavior is acceptable or even useful, but the full implications need to be understood and the case carefully weighed before implementing any behavior described with this label.
MAY	This word, or the term “OPTIONAL”, means that this item is one of an allowed set of alternatives. An implementation that does not include this option MUST be prepared to inter-operate with another implementation that does include the option.

2.2 References

The following references are of relevance to this Test Plan. At the time of publication, the editions indicated were valid. All references are subject to revision; users of this Test Plan are therefore encouraged to investigate the possibility of applying the most recent edition of the references listed below.

A list of currently valid Broadband Forum Technical Reports is published at www.broadband-forum.org.

Document	Title	Source	Year
[1] G.9701	<i>Fast access to user terminals (G.fast) - Physical layer specification</i>	ITU-T	2014
[2] G.984.2	<i>Gigabit-capable Passive Optical Networks (G-PON): Physical Media Dependent (PMD) layer specification</i>	ITU-T	2003
[3] G.984.3	<i>Gigabit-capable Passive Optical Networks (G-PON): Transmission convergence layer specification</i>	ITU-T	2008
[4] G.987.2	<i>10-Gigabit-capable passive optical networks (XG-PON): Physical media dependent (PMD) layer specification</i>	ITU-T	2010
[5] G.987.3	<i>10-Gigabit-capable passive optical networks (XG-PON): Transmission convergence (TC) layer specification</i>	ITU-T	2010
[6] G.988 (2010)	<i>ONU Management and Control Interface (OMCI) Specification¹</i>	ITU-T	2010
[7] G.988 (2012)	<i>ONU Management and Control Interface (OMCI) Specification¹</i>	ITU-T	2012
[8] G.988 (2017)	<i>ONU Management and Control Interface (OMCI) Specification¹</i>	ITU-T	2017
[9] G.993.2	<i>Very high speed digital subscriber line transceivers 2(VDSL2)</i>	ITU-T	2011
[10] G.9807.1	<i>10-Gigabit-capable symmetric passive optical network (XGS-PON)²</i>	ITU-T	2016
[11] G.9807.2	<i>10 Gigabit-capable passive optical networks (XG(S)-PON): Reach extension²</i>	ITU-T	2017
[12] RFC 2119	<i>Key words for use in RFCs to Indicate Requirement Levels</i>	IETF	1997
[13] IR-337 Issue 2	<i>G.fast Certification Test Plan</i>	Broadband Forum	2019
[14] IR-247 Issue 3 Amendment 1	<i>GPON & XG-PON ONU Conformance Test Plan Issue 3 Amendment 1</i>	Broadband Forum	2014
[15] IR-247 Issue 3 Amendment 2	<i>GPON & XG-PON ONU Conformance Test Plan Issue 3 Amendment 2</i>	Broadband Forum	2018
[16] TR-101 Issue 2	<i>Migration to Ethernet-Based Broadband Aggregation</i>	Broadband Forum	2011
[17] TR-114 Issue 2	<i>VDSL2 Performance Test Plan</i>	Broadband Forum	2012
[18] TR-156 Issue 2	<i>Using G-PON Access in the context of TR-101</i>	Broadband Forum	2010
[19] TR-156 Issue 3	<i>Using G-PON Access in the context of TR-101</i>	Broadband Forum	2012

¹ and its amendments

² and its amendments

Document	Title	Source	Year
[20] TR-156 Issue 4	<i>Using G-PON Access in the context of TR-101</i>	Broadband Forum	2017
[21] TR-167 Issue 2	<i>G-PON -fed TR-101 Ethernet Access Node</i>	Broadband Forum	2012
[22] TR-178 Issue 2	<i>Multi-service Broadband Network Architecture and Nodal Requirements</i>	Broadband Forum	2017
[23] TR-280 Issue 1	<i>ITU-T PON in the context of TR-178</i>	Broadband Forum	2016
[24] TR-280 Issue 1 Amendment 1	<i>ITU-T PON in the context of TR-178</i>	Broadband Forum	2020
[25] TR-301 Issue 2	<i>Architecture and Requirements for Fiber to the Distribution Point</i>	Broadband Forum	2017

2.3 Definitions

The following terminology is used throughout this Test Plan.

DPU	Distribution Point Unit
Ethernet Traffic Generator	A device that generates and captures well-formed Ethernet frames as defined by test personnel.
GEM Port	An abstraction on the GTC adaptation sublayer representing a logical connection associated with a specific client traffic flow. The GTC adaptation sublayer is a sublayer of the G-PON Transmission Convergence layer that supports the functions of user data fragmentation and de-fragmentation, GEM encapsulation, GEM frame delineation, and GEM Port-ID filtering.
GEM Port Id	A 12-bit value which is assigned by the OLT to the individual logical connections transported over the G-PON interface and which is carried in the header of all the GEM frames associated with the given logical connection.
G-PON Analyzer	An external device, which may be included in a non-intrusive manner, between the R/S and S/R-interfaces to capture and analyze the traffic present in the ODN
G-PON Network	An OLT connected using an Optical Distribution Network (ODN) to one or more ONUs or ONTs. A G-PON network is a subset of the Access Network.
ME	Managed Entity
Gfast, G.fast	Local loop access technology based on ITU-T G.9700 and G.9701 protocol standard, see [7]

ODN	Optical Distribution Network including the fibers, splitters and connectors.
OLT	Optical Line Termination (OLT): A device that terminates the common (root) endpoint of an ODN, implements a PON protocol, such as that defined by G.984, for G-PON and G.987 for XG-PON, and adapts PON PDUs for uplink communications over the provider service interface. The OLT provides management and maintenance functions for the subtended ODN and ONUs.
OLT Emulator	A device that terminates the common (root) endpoint of an ODN, implements the G.984/G.987 PMD and TC layers, and supports the transmission of OMCI messages as defined in the messages sequences in this document.
ONU	Optical Network Unit (ONU): A generic term denoting a device that terminates any one of the distributed (leaf) endpoints of an ODN, implements a PON protocol, and adapts PON PDUs to subscriber service interfaces.
ONU/L2	A generic term denoting a Layer-2 device that terminates any one of the distributed (leaf) endpoints of an ODN, implements a PON protocol, and adapts PON PDUs to subscriber service interfaces. The ONU, within the context of TR-156, does not include any Layer-3 (IP router) functions.
ONU/RG	An ONU (as defined above) that includes additional Layer-3 (IP routing) functionality as defined as “RG” below. The connection between the ONU subcomponent and RG subcomponent is made through a VEIP managed entity.
RG	A Residential Gateway is a device that interfaces between the WAN and LAN IP environment for a consumer broadband customer. It may route or bridge traffic, depending on its configuration and specifications.
T-CONT	A traffic-bearing object within the ONU that represents a group of logical connections, is managed via the ONU Management and Control Channel (OMCC) and is treated as a single entity for the purpose of upstream bandwidth assignment on the PON.
Traffic Flow	A sequence of frames or packets traversing a particular reference point within a network that share a specific frame/packet header pattern. For example, an Ethernet traffic flow can be identified by any combination of specific source MAC address, destination MAC, VLAN ID, 802.1p bits, etc.
Traffic Classes	(TC) - Traffic Classes are the set of upstream and downstream supported forwarding behaviours in the network element
U-interface	U-interface is a short form of expressing one or more of the interfaces defined in this Other Document or in TR-101 at the U reference point. It is also essentially equivalent to a subscriber-facing interface at the access node.
V-interface	V-interface is a short form of expressing one or more of the interfaces defined in TR-101 at the V reference point. It is also essentially equivalent to a network-facing interface at the access node

XGEM Port	An abstraction on the XGTC adaptation sublayer representing a logical connection associated with a specific client traffic flow. The XGTC adaptation sublayer is a sublayer of the XG-PON Transmission Convergence layer that supports the functions of user data fragmentation and de-fragmentation, XGEM encapsulation, XGEM frame delineation, and XGEM Port-ID filtering.
XGEM Port Id	A 16-bit value which is assigned by the OLT to the individual logical connections transported over the XG-PON interface and which is carried in the header of all the XGEM frames associated with the given logical connection.

2.4 Abbreviations

This Test Plan uses the following abbreviations:

ADSL	Asymmetric Digital Subscriber Line
AES	Advanced Encryption Standard
AN	Access Node
ARP	Address Resolution Protocol
ASP	Application Service Provider
ATM	Asynchronous Transfer Mode
BTS	Base Transceiver Station
CB	Cellular Backhaul
CPE	Customer Premises Equipment
CPN	Customer Premises Network
CRC	Cyclic Redundancy Check
DHCP	Dynamic Host Configuration Protocol
DPU	Distribution Point Unit
DSCP	DiffServ Code Point
DSL	Digital Subscriber Line
FE	Fast Ethernet (100Mbps)
FITH	Fiber into the Home
FTTC	Fiber to the Curb
FTTH	Fiber to the Home

FTTO	Fiber to the Office
FFTP	Fiber to the Premises, including buildings
GE	Gigabit Ethernet (1000Mbps)
GEM	Generic Encapsulation Method
GPM	G-PON Physical Media layer
G-PON	Gigabit-capable Passive Optical Network
GTC	G-PON Transmission Convergence layer – as defined in G.984.3 [3] for G-PON , and G.987.3 [5] for XG-PON (see XGTC)
IGMP	Internet Group Management Protocol
L2-OCM	Layer 2 OMCI Common Model
MAC	Media Access Control
MIB	Management Information Base
MDU	Multi-Dwelling Unit
ME	Managed Entity
MTU	Multi-Tenant Unit – or Maximum Transmission Unit
NSP	Network Service Provider
ODN	Optical Distribution Network – as defined in G.984.1 for G-PON and G.987.1 for XG-PON and G.9807 for XGS-PON
OLT	Optical Line Termination – as defined in G.984.1 for G-PON and G.987.1 for XG-PON and G.9807 for XGS-PON
OMCI	ONU Management and Control Interface
ONT	Optical Network Termination – as defined in G.984.1 for G-PON and G.987.1 for XG-PON and G.9807 for XGS-PON
ONU	Optical Network Unit – as defined in G.984.1 for G-PON and G.987.1 for XG-PON and G.9807 for XGS-PON
OTS	Plain Old Telephone Service
PM	Performance Monitoring
P-bit	Priority Bit
RBN	Regional Broadband Network
RG	Residential Gateway
RNC	Radio Network Controller

SFU	Single Family Unit – a type of residence
SFP	Small Form Factor Pluggable device
TDM	Time-Division Multiplexing
TLS	Transparent LAN Service – a common synonym for Business Ethernet Services
TP	Test Plan
TR	Technical Report
VDSL	Very highspeed Digital Subscriber Line
VID	Virtual local area network Identifier
VLAN	Virtual Local Area Network
WA	Work Area
xDSL	Any variety of DSL
XG-PON	10-Gigabit-capable passive optical network
XGTC	XG-PON Transmission Convergence layer – as defined in G.987.3 [5]

3 Test Plan Impact

3.1 Energy Efficiency

TP-247 has no impact on energy efficiency.

3.2 Security

TP-247 has no impact on security.

3.3 Privacy

TP-247 has no impact on privacy.

4 Test Methodology

The implementers of this test plan are expected to adhere to a set of requirements that provide uniformity of test configurations and equipment across multiple test venues. The following subsections define these requirements.

4.1 Standards Conformance Testing

Conformance testing is intended to verify a specific implementation of an ONU, including the OMCI stack and configuration engines, is compliant with requirements of the specification. Within conformance testing, only the unit under test and any necessary test tools shall be connected to the ODN, as defined below in 4.4.6. It is recommended that the sequence of test cases in a conformance test be randomized such that the sequence of test cases varies between test sessions. It is also recommended that the ONU be reset to its factory default configuration between each test case.

4.2 ONU Testing Requirements

The certification program described in the present document applies to integrated ONU devices of the following types:

- Single User Port ONU/L2
- Multiple User Port ONU/L2
- Multi-managed ONUs
 - o Residential Gateway ONU (ONU/RG)
 - o SFP ONU (ONU/SFP)
 - o PON fed VDSL2 DPU ONU (VDSL2 DPU/ONU)
 - o TR-301 Model 2 Gfast DPU/ONU

These ONU types are further discussed and defined in Sections 4.2.2 and 4.2.3, respectively. It may be possible to specify and test other ONU device types, however at this time, those device types are out of scope of the certification program.

4.2.1 ONU Clean-slate Requirements

Unless explicitly stated in each test case, the ONU must be returned to a “clean-slate” state before the beginning of each test run. Such clean-slate state may either be achieved through the following steps:

1. The ONU under test is connected to ODN and powered up.
2. The ONU is activated by the OLT Emulator, ranged, and a GEM port for OMCI is created as a result of ONU-ID assignment.
3. The OLT Emulator instructs the ONU to reset its MIB to factory default values.

Or by any mean specific to the ONU.

Note that these steps may be redundant with the first steps of a given test-case configuration: in such a case, they need not be repeated. It is also assumed that the testing equipment (Ethernet Traffic Generator and the OLT Emulator, analyzers, etc.) has been powered up, connected to the ODN, and is configured such that it can perform the actions ascribed to it in the current test – how this is achieved, provided that the OLT Emulator and G-PON analyzer abide by the requirements defined in their respective sections (OLT Emulator requirements and G-PON analyzer requirements), is irrelevant. In particular, the OLT Emulator may perform MIB uploads in order to obtain a precise knowledge of the actual state of the ONU.

Unless explicitly stated, identical steps may not be shared between test runs, and any given test must be run from start (including a return to its required pre-existing state, be it the defined clean-slate state or otherwise stated) to its end independently.

4.2.2 ONU/L2

An integrated ONU/L2 device is an ONU integrating and implementing Ethernet type user interface connections (that is, the U-interface of TR-156 [18][19][20]) that operates exclusively on and below Layer 2 of the protocol stack. In particular, an ONU/L2 excludes any IP routing or NAT functionality. To be certified, an ONU/L2 MUST successfully complete all mandatory and conditional test cases for each applicable profile. The applicable profiles, with the exception of the baseline profile, are selected by the manufacturer and communicated to the test laboratory prior to the start of testing. All ONU/L2 devices under certification must support the Baseline Profile requirements.

Note that a Single User Port ONU/L2 MUST successfully complete all mandatory and conditional test cases for Single User Port, whereas Multiple User Ports ONU/L2 MUST successfully complete all mandatory and conditional test cases for Multiple User Ports.

Table 4-1: Profile A – N:1 VLAN Architecture

Test Number	Test Name	Test Requirement(s)	Test Type
ONU.6.1.1	Single untagged U-interface	TR-156 R-10, R-11, R-19	Mandatory
ONU.6.1.2	Single U-interface with symmetric VLAN tag translation	TR-156 R-12, R-13, R-19	Mandatory
ONU.6.1.3	Deriving P-bits as a function of received P-bits (single user port)	TR-156 R-48	Mandatory
ONU.6.1.13	VID Support for Untagged Frames (N:1 VLAN or 1:1 VLAN Architecture Single-Tagged at the V Interface)	TR-156 R-9	Mandatory
ONU.6.1.15	VID Support for Priority Tagged Frames with Priority Preservation (N:1 VLAN or 1:1 VLAN Architecture Single-Tagged at the V Interface)	TR-156 R-9	Mandatory
ONU.6.1.16	VID Support for Priority Tagged Frames without Priority Preservation (N:1 VLAN or 1:1 VLAN Architecture Single-Tagged at the V Interface)	TR-156 R-9	Mandatory
ONU.6.1.25	Deriving P-bits as a function of received VID for a 1:1 or N:1 architecture (single user port)	TR-156 R-48	Mandatory
ONU.6.1.26	Deriving P-bits as a function of received Ethertype for a 1:1 or N:1 architecture (single user port)	TR-156 R-48	Mandatory

Test Number	Test Name	Test Requirement(s)	Test Type
ONU.6.1.27	Deriving P-bits as a function of received user port for a 1:1 or N:1 architecture	TR-156 R-48	Conditionally Mandatory

Table 4-2: Profile B – 1:1 VLAN Architecture

Test Number	Test Name	Test Requirement(s)	Test Type
ONU.6.1.1	Single untagged U-interface	TR-156 R-20, R-21, R-31	Mandatory
ONU.6.1.2	Single U-interface with symmetric VLAN tag translation	TR-156 R-22, R-23, R-31	Mandatory
ONU.6.1.3	Deriving P-bits as a function of received P-bits (single user port)	TR-156 R-48	Mandatory
ONU.6.1.13	VID Support for Untagged Frames (N:1 VLAN or 1:1 VLAN Architecture Single-Tagged at the V Interface)	TR-156 R-9	Mandatory
ONU.6.1.14	VID Support for Untagged Frames (1:1 VLAN Architecture Double-Tagged at the V Interface)	TR-156 R-9	Mandatory
ONU.6.1.15	VID Support for Priority Tagged Frames with Priority Preservation (N:1 VLAN or 1:1 VLAN Architecture Single-Tagged at the V Interface)	TR-156 R-9	Mandatory
ONU.6.1.16	VID Support for Priority Tagged Frames without Priority Preservation (N:1 VLAN or 1:1 VLAN Architecture Single-Tagged at the V Interface)	TR-156 R-9	Mandatory
ONU.6.1.17	VID Support for Priority Tagged Frames with Priority Preservation (1:1 VLAN Architecture Double-Tagged at the V Interface)	TR-156 R-9	Mandatory
ONU.6.1.18	VID Support for Priority Tagged Frames without Priority Preservation (1:1 VLAN Architecture Double-Tagged at the V Interface)	TR-156 R-9	Mandatory
ONU.6.1.19	ONU addition and removal of C-Tag for 1:1 VLANs	TR-156 R-20, R-21	Mandatory
ONU.6.1.20	ONU addition and removal of S-Tag for 1:1 VLANs	TR-156 R-20, R-21	Mandatory
ONU.6.1.21	ONU translation between Q-Tag and C-Tag for 1:1 VLANs	TR-156 R-22, R-23	Mandatory
ONU.6.1.22	ONU translation between Q-Tag and S-Tag for 1:1 VLANs	TR-156 R-22, R-23	Mandatory
ONU.6.1.25	Deriving P-bits as a function of received VID for a 1:1 or N:1 architecture (single user port)	TR-156 R-48	Mandatory
ONU.6.1.26	Deriving P-bits as a function of received Ethertype for a 1:1 or N:1 architecture (single user port)	TR-156 R-48	Mandatory

Test Number	Test Name	Test Requirement(s)	Test Type
ONU.6.1.27	Deriving P-bits as a function of received user port for a 1:1 or N:1 architecture	TR-156 R-48	Conditionally Mandatory

Table 4-3: Profile C – VBES VLAN Architecture

Test Number	Test Name	Test Requirement(s)	Test Type
ONU.6.1.4	Addition of an S-Tag in the Upstream Direction in a VBES Architecture	TR-156 R-34	Mandatory
ONU.6.1.5	Validation of an S-Tag in the Upstream Direction in a VBES Architecture	TR-156 R-35	Mandatory
ONU.6.1.6	Translation of an S-Tag in the Upstream Direction in a VBES Architecture	TR-156 R-35, R-42	Mandatory
ONU.6.1.7	Removal of an S-Tag in the Downstream Direction in a VBES Architecture	TR-156 R-36	Mandatory
ONU.6.1.8	Translation of an S-Tag in the Downstream Direction in a VBES Architecture	TR-156 R-43	Mandatory
ONU.6.1.10	Deriving P-bits as a function of received VID (single user port)	TR-156 R-48	Mandatory
ONU.6.1.11	Deriving P-bits as a function of received Ethertype (single user port)	TR-156 R-48	Mandatory
ONU.6.1.12	Deriving P-bits as a function of received user port	TR-156 R-48	Conditionally Mandatory
ONU.6.1.24	Deriving P-bits as a function of received P-bits for a VBES architecture (single user port)	TR-156 R-48	Mandatory
ONU.6.2.3	Mapping Traffic from GEM Ports to U Interface in the Downstream Direction in a VBES Architecture	TR-156 R-41	Mandatory

Table 4-4: Profile D – Multicast Operations

Test Number	Test Name	Test Requirement(s)	Test Type
ONU.6.3.1	ONU passing of downstream IGMP messages	TR-156 R-81	Mandatory
ONU.6.3.3	ONU silent discarding of IGMPv1 messages	TR-156 R-98	Mandatory
ONU.6.3.5	Marking Upstream IGMP Messages with Ethernet P-Bits	TR-156 R-94	Mandatory
ONU.6.3.6	IGMP controlled Multicast	TR-156 R-74, R-79	Mandatory

Test Number	Test Name	Test Requirement(s)	Test Type
ONU.6.3.7	Multicast White List	TR-156 R-76, R-84	Mandatory
ONU.6.3.8	IGMP rate limit	TR-156 R-87	Mandatory
ONU.6.3.9	IGMP immediate leave	TR-156 R-91	Mandatory
ONU.6.3.10	Maximum number of multicast flows	TR-156 R-97	Mandatory
ONU.6.3.11	IGMP transparent Snooping	TR-156 R-88, R-89, R-90	Mandatory
ONU.6.3.12	Multicast VLAN membership based on user ports (Multiple User ports)	TR-156 R-96	Conditionally Mandatory
ONU.6.3.13	IGMP transparent Snooping (Multiple User ports)	TR-156 R-88, R-89, R-90	Conditionally Mandatory
ONU.6.3.14	IGMP Transparent forwarding	TR-156 R-10, R-19, R-82	Mandatory

Table 4-5: Profile E – Enhanced Operations

Test Number	Test Name	Test Requirement(s)	Test Type
ONU.6.1.29	Verifying MAC Address is not used as a Classification Criterion	TR-156 R-48, R-51, R-6, R-7, R-50	Mandatory
ONU.6.1.30	Downstream Translation for Code Point 0	TR-280 R-61	Mandatory
ONU.6.1.31	Downstream Translation for Code Point 1	TR-280 R-61	Mandatory
ONU.6.1.32	Downstream Translation for Code Point 2	TR-280 R-61	Mandatory
ONU.6.1.33	Downstream Translation for Code Point 3	TR-280 R-61	Mandatory
ONU.6.1.34	Downstream Translation for Code Point 4	TR-280 R-61	Mandatory
ONU. 6.1.35	Downstream Translation for Code Point 5	TR-280 R-61	Mandatory
ONU. 6.1.36	Downstream Translation for Code Point 6	TR-280 R-61	Mandatory
ONU.6.1.37	Downstream Translation for Code Point 7	TR-280 R-61	Mandatory
ONU.6.1.38	Downstream Translation for Code Point 8	TR-280 R-61	Mandatory
ONU.6.2.25	Strict Priority Downstream Scheduling Among 2 Queues on ONU with Unicast and Multicast Traffic	TR-156 R-46, R-56, R-63, R-64	Mandatory

Test Number	Test Name	Test Requirement(s)	Test Type
ONU.6.9.4	U interface status reporting and alarms	TR-280 R-48, R-49, R-51	Conditionally Mandatory
ONU.6.9.5	Optical parameters counters and alarms	TR-280 R-41, R-43	Mandatory
ONU.6.9.6	OMCI reboot with OMCI configuration persistence	ITU-T G.988 Appendix I	Conditionally Mandatory
ONU.6.9.7	OMCI reboot without OMCI configuration persistence	ITU-T G.988 Appendix I	Conditionally Mandatory
ONU.6.9.8	OMCI Reset & MIB synchronization	ITU-T G.988 Appendix I	Mandatory
ONU.6.12.1	Dying Gasp Emission	TR-280 R-44	Mandatory
ONU.6.12.2	Create and Modify Configuration	TR-280 Amendment 1 R-90, R-91, R-92, R-93	Mandatory
ONU.6.12.3	Unicast GEM port encryption in the downstream direction	TR-280 R-66	Mandatory
ONU.6.12.4	GEM port Encryption in the Upstream Direction	TR-280 R-66	Conditionally Mandatory
ONU.6.12.5	ONU Remote Debug	TR-280 R-57, R-59	Mandatory
ONU.6.12.6	Create, Delete and Add New Services	TR-156 R-63 TR-280 Amendment 1 R-90, R-91, R-92, R-93	Mandatory
ONU.6.12.7	Create, Delete and Add New Services in Strict Priority Downstream Scheduling Context	TR-156 R-63 TR-280 Amendment 1 R-90, R-91, R-92, R-93	Conditionally Mandatory

Table 4-6: Profile F – Enhanced Multicast Operations

Test Number	Test Name	Test Requirement(s)	Test Type
ONU.6.3.15	Maximum Multicast Bandwidth	TR-280 R-19, R-20, R55	Mandatory
ONU.6.3.16	VID and P-bit Translation in Upstream and Downstream for IGMP/MLD and Multicast Packets	TR-280 R-16, R-17	Mandatory

Test Number	Test Name	Test Requirement(s)	Test Type
ONU.6.3.17	Create and Remove Multicast Groups in the Dynamic Access Control List table	TR-280 Amendment 1 R-75, R-76, R-77, R-78	Mandatory
ONU.6.3.18	Maximum Number of Dynamic Multicast Groups Modification	TR-280 Amendment 1 R-79, R-80	Mandatory
ONU.6.3.19	Maximum Multicast Bandwidth Modification	TR-280 Amendment 1 R-81, R-82	Mandatory
ONU.6.3.21	Whole Multicast Range in Dynamic Access Control List table	TR-280 R-23	Mandatory

Table 4-7: Profile G – Capacity Test Cases

Test Number	Test Name	Test Requirement(s)	Test Type
ONU.6.1.28	Support of 67 Entries on extended VLAN tagging operation table and 8 VLANs	TR-280 R-63, R-64	Mandatory
ONU.6.3.20	Individual multicast groups in Dynamic Access Control List table	TR-280 Amendment 1 R-83	Conditionally Mandatory

Table 4-8: Profile H – Monitoring Test Cases

Test Number	Test Name	Test Requirement(s)	Test Type
ONU.6.13.1	Performance Monitoring on Ethernet Frames	TR-280 R-25, R-27, R-31, R-36, R-37, R-38, R-39, R-40 TR-280 Amendment 1 R-84, R-85, R-86	Mandatory
ONU.6.13.2	Performance Monitoring on Multicast Ethernet Frames	TR-280 R-25, R-27, R-31, R-36, R-37, R-38, R-39, R-40 TR-280 Amendment 1 R-84, R-85, R-86	Conditionally Mandatory

Table 4-9: Profile I – Extended OMCI Messages Format Test Cases

Test Number	Test Name	Test Requirement(s)	Test Type
ONU.6.9.9	Use of Extended OMCI in a MIB Upload Using the Minimal Data Allocation Size	ITU-T G.988 Annex A TR-280 Amendment 1 R-89	Conditionally Mandatory
ONU.6.9.10	Use of Extended OMCI in a MIB Upload with Maximum Upstream Bandwidth	ITU-T G.988 Annex A TR-280 Amendment 1 R-89	Conditionally Mandatory
ONU.6.10.9	Use of Extended OMCI in a Software Download with the Minimal and Variable Section Size	ITU-T G.988 Annex A TR-280 Amendment 1 R-89	Conditionally Mandatory
ONU.6.10.10	Use of Extended OMCI in a Software Download using the OMCI Maximum Message Size	ITU-T G.988 Annex A TR-280 Amendment 1 R-89	Conditionally Mandatory
ONU.6.10.11	Use of Extended OMCI in a Software Download with a 33 bytes OMCI payload size	ITU-T G.988 Annex A TR-280 Amendment 1 R-89	Conditionally Mandatory

Table 4-10: Baseline Test Cases

Test Number	Test Name	Test Requirement(s)	Test Type
ONU.6.4.1	Downstream Broadcast Handling, Single U-interface	TR-156 R-113	Mandatory
ONU.6.4.2	Downstream Broadcast Handling, Multiple U-interfaces	TR-156 R-113	Conditionally Mandatory
ONU.6.6.1	2000-Byte Frames Supported by the ONU	TR-156 R-4	Conditionally Mandatory
ONU.6.7.1	Local setting of a registration ID at the ONU (ONU retains the Registration ID indefinitely)	TR-156 R-152, R-153	Conditionally Mandatory
ONU.6.8.1	New ONU Bring-up method for new ONU	G.988 Appendix I	Mandatory
ONU.6.8.2	New ONU Bring-up method for old ONU	G.988 Appendix I	Mandatory
ONU.6.8.3	Old ONU Bring-up method for ONU	G.988 Appendix I	Mandatory
ONU.6.8.4	New ONU Bring-up method for new ONU with encrypted OMCC	G.988 Appendix I	Mandatory

Test Number	Test Name	Test Requirement(s)	Test Type
ONU.6.9.1	Alarm synchronization	G.988 Appendix I	Conditionally Mandatory
ONU.6.9.2	MIB synchronization: Correct Data Sync	G.988 Appendix I	Mandatory
ONU.6.9.3	MIB synchronization: MIB Upload	G.988 Appendix I	Mandatory
ONU.6.10.1	Software Image Download, multiple window sizes, padded final window	G.988 Appendix I	Mandatory
ONU.6.10.2	Software Image Download, shortened final window	G.988 Appendix I	Mandatory
ONU.6.10.3	Failed Software Image Download, missing section	G.988 Appendix I	Mandatory
ONU.6.10.4	Failed Software Image Download, incorrect section CRC	G.988 Appendix I	Mandatory
ONU.6.10.5	Failed Software Image Download, incorrect software image CRC	G.988 Appendix I	Mandatory
ONU.6.10.7	Activate uncommitted software image	G.988 Appendix I	Mandatory
ONU.6.10.8	Commit software image	G.988 Appendix I	Mandatory
ONU.6.11.3	Cardholder or port mapping package for integrated ONU	G.988 Appendix I	Conditionally Mandatory
ONU.6.2.1	Single U-interface with multiple downstream GEM ports	TR-156 R-19, R31, R-41	Mandatory
ONU.6.2.2	User Isolation on ONU Devices with Multiple U-interfaces	TR-156 R-3 (TR-101 R-40)	Conditionally Mandatory
ONU.6.2.4	Mapping traffic into GEM Ports based on P-bit values in the upstream direction (single user port)	TR-156 R-51, R-52, R-53	Mandatory
ONU.6.2.5	Mapping traffic into GEM Ports based on VID values in the upstream direction (single user port)	TR-156 R-51, R-52, R-53	Mandatory
ONU.6.2.6	Mapping traffic into GEM Ports based on VID & P-bit values in the upstream direction (single user port)	TR-156 R-51, R-52, R-53	Mandatory
ONU.6.2.7	Mapping traffic into GEM Ports based on P-bit values in the upstream direction (multiple user port)	TR-156 R-51, R-52, R-53	Conditionally Mandatory
ONU.6.2.8	Mapping traffic into GEM Ports based on VID values in the upstream direction (multiple user port)	TR-156 R-51, R-52, R-53	Conditionally Mandatory
ONU.6.2.9	Mapping traffic into GEM Ports based on VID & P-bit values in the upstream direction (multiple user port)	TR-156 R-51, R-52, R-53	Conditionally Mandatory

Test Number	Test Name	Test Requirement(s)	Test Type
ONU.6.2.10	Mapping multiple P-bit values to the same GEM port (single user port)	TR-156 R-51	Mandatory
ONU.6.2.12	Strict priority downstream scheduling among 4 queues on ONU	TR-156 R-56, R-63, R-64	Mandatory
ONU.6.2.13	Indicating drop precedence using P-bits upstream	TR-156 R-54	Mandatory
ONU.6.2.14	Indicating drop precedence using DEI bit upstream	TR-156 R-55	Mandatory
ONU.6.2.15	Indicating drop precedence using P-bits downstream	TR-156 R-54	Mandatory
ONU.6.2.16	Indicating drop precedence using DEI bit downstream	TR-156 R-55	Mandatory
ONU.6.2.19	Mapping Traffic from GEM Ports to Multiple U Interfaces in the Downstream Direction	TR-156 R-19, R-31, R-41	Conditionally Mandatory
ONU.6.2.21	Mapping Traffic from GEM Ports to Multiple U Interfaces in the Downstream Direction	TR-156 R-19, R-31, R-41	Conditionally Mandatory
ONU.6.8.5	OMCI Version During New ONU Bring Up	G.988 section 11.1 TR-280 Amendment 1 R-87	Mandatory

4.2.3 Multi-managed ONU

Multi-managed ONUs are devices integrating both an OMCI management domain and at least one or more non-OMCI management domains (like TR-069, SNMP, etc.).

In such multi-managed ONU types, the U-interface is virtualized as the Virtual Ethernet Interface Point (VEIP) which represents the data plane hand-off point to the non-OMCI management domain(s). This point is however not directly accessible externally, and the certification program supports only the implementations in which at least one association between Ethernet UNI and VEIP is maintained by default (which means one VEIP per non-OMCI management domain).

Per requirement **R-68** of TR-280 [23], the certification program also supports implementations having U-interfaces virtualized as PPTP Ethernet UNI MEs (PPTPs). In this later context, the PPTP MEs represent the data plane hand-off point to the non-OMCI management Gfast domain(s).

Whereas other possible implementations than VEIPs may exist for that purpose (the use of the IPhost OMCI object and freely associated PPTP Ethernet UNIs is possible when a separate IP management domain is present), testing of such other implementations is not covered in the present document and is for further study.

Multi-managed ONU devices covered in the present document are:

- Residential Gateway ONU (**ONU/RG**), see § 4.2.3.1 specific requirements

- Small Form Factor Pluggable ONU (**SFP/ONU**) and its related system under test, see § 4.2.3.2 for specific requirements
- PON fed VDSL2 Distribution Point Unit ONU (**VDSL2 DPU/ONU**) and its related system under test, see § 4.2.3.3 for specific requirements

Each of these ONU devices and their related system under test may be either with a single VEIP or multiple VEIPs, except in the SFP/ONU case where the system under test (the SFP/ONU plus the Host device) is expected to be with a single VEIP only.

To be certified, a multi-managed ONU MUST successfully complete all mandatory and conditional test cases for each applicable profile. Available profiles are identical to those defined above for the ONU/L2 type. The applicable profiles tested, with the exception of the baseline profile, are selected by the manufacturer and communicated to the approved test laboratory prior to the start of testing. All multi-managed ONU devices under certification MUST support the Baseline Profile requirements with the exception of the *Test Case 6.9.1 Alarm synchronization* that does not apply to multi-managed ONUs types. Profile H – Monitoring Test Cases is not applicable for Multi Managed ONUs implementing a VEIP interface as a demarcation interface to the non-OMCI domain.

In order to be applicable to multi-managed ONUs, the TP-247 test cases may require textual modifications of their OMCI message sequences depending on the way their U-interfaces are virtualized, either as PPTPs or VEIPs:

- For multi-managed ONUs virtualizing their U-interfaces as PPTPs, the OMCI message sequences are identical to those applying to ONU/L2 types
- For multi-managed ONUs virtualizing their U-interfaces as VEIPs, each OMCI test script differs from the scripts used for testing ONU/L2 devices in the following ways:
 1. All references to the PPTP Ethernet ME are changed to the VEIP ME.
This largely includes changing the bridge-port configuration data and extended VLAN tagging configuration data, and Ethernet frame extended PM ME OMCI commands and associations.
 2. The unlocking operation at the end of each script should apply to the VEIP rather than to the PPTP Ethernet Port.

All applicable and required OMCI message sequences, including the modified sequences for the testing of multi-managed ONUs, are referenced in clause 4.3 OMCI of the present document.

The certification program supports only ONU implementations (and their related system under test) that do not require provisioning of IP parameters via OMCI. To simplify the testing and remove the necessity of the inclusion of IP information in test packets, all multi-managed ONU and its associated system under test MUST support and allow the implementation of at least one of the following modes:

Mode 1

A pure bridging mode, where all packets are forwarded between the physical user-facing Ethernet ports of the system under test and the VEIP point, regardless of VLAN tagging, P-bit value, etc.

Mode 2

A stripped mode, where a physical Ethernet user-facing port of the system under test receives only untagged Ethernet frames, and where it is the responsibility of the internal non-OMCI management domain of the system under test to perform the correct tag addition or manipulation so that the traffic at the VEIP point equals the traffic at the U interface as defined for each test-case.

4.2.3.1 Residential Gateway ONU (ONU/RG)

An integrated ONU/RG device is an ONU that combines the Layer 2 functionality with that of the residential gateway.

The certification program supports only the ONU/RG device implementations that do not require provisioning of IP parameters via OMCI.

To meet the requirements of mode 2, the internal RG device MUST/SHOULD support the following requirements from TR-101 [16]:

TR-101 Requirements

- **R-01** The RG MUST support sending the following frame types: untagged frames, priority-tagged frames and VLAN-tagged Ethernet frames in the upstream direction for stacks a, b, e, f and g in Figure 4 [of TR-101.]
- **R-02** The RG used to support business customers SHOULD support sending double-tagged Ethernet frames in the upstream direction for stacks a, b, e, f and g in Figure 4 [of TR-101.]
- **R-03** The RG MUST support setting the priority tag and VLAN ID values.
- **R-04** The RG MUST support receiving untagged and VLAN tagged Ethernet frames in the downstream direction and MUST be able to strip the VLAN tagging from the ones received with tags.

4.2.3.2 Small Form Factor Pluggable ONU (SFP/ONU)

SFP/ONUs are ONU devices whose purpose is to be hosted within L2 switch or L3 router devices and which cannot be tested alone as such. The testing of SFP/ONUs MUST therefore be done along with the use of a host device specified by the manufacturer and communicated to the approved test laboratory prior to the start of testing. The system under test will thus result in the combination of the SFP/ONU and its host device. The model part number and all relevant HW and SW references of the hosting device will be reported by the approved test laboratory in the test report along with the related SFP/ONU information.

Host devices may be of great variety and of different natures, making the entire system under test be potentially assimilated to an already covered type of ONUs: for instance, the SFP/ONU and its host may result into an ONU/RG, or into a xDSL DPU/ONU. In such case, the requirements of the equivalent ONU type then applies to the system under test composed of the SFP/ONU and its host device.

The certification program supports only implementations (SFP/ONU device and its host) where the host does not require any provisioning via OMCI.

4.2.3.3 PON fed VDSL2 Distribution Point Unit ONU (VDSL2 DPU/ONU)

VDSL2 DPU/ONU devices are integrated PON-fed (G-PON or XG-PON) VDSL2 access equipments (DSLAMs) that combine a PON ONU entity along with a VDSL2 access node entity. In such case, the IR-247 test setup MUST include an active VDSL2 link from the VDSL2 DPU/ONU to the VDSL2 end-user CPE, the system under test resulting in the combination of the VDSL2 DPU/ONU itself plus a VDSL2 CPE with an active VDSL2 link. It is of responsibility of the manufacturer in accordance with the approved test laboratory to make a proper choice of the VDSL2 CPE hardware & software, as well of the VDSL2 link

configuration used during the certification tests. The VDSL2 configuration information MUST be reported by the approved test laboratory in the test report in order to allow the IR-247 tests to be re-executed in the same configuration. Such information MUST include all needed VDSL2 parameters such as Band Profiles and Line Settings, including parameters among with: used G.993.2 annex, band plans, US0 band, PSD mask, spectrum/service profiles, UPBO/DPBO, latency, INP. Further information might be reported as necessary to allow the testing being reproduced, and settings examples can be taken from the section 6.2 of the BBF TR-114 issue 2 test plan [17].

Special care in the elaboration and choice of the VDSL2 link must be taken as this additional link might be of great influence upon the IR-247 tests. Especially, manufacturer in accordance with the approved test laboratory MUST define the VDSL2 settings so that it does not preclude the successful execution of the IR-247 test plan.

The certification program supports only implementations of VDSL2 DPU/ONUs and their related system under test which support the following requirements from TR-167 issue 2 [21]:

TR-167 Requirements

- **R-68** All the configurable features of the G-PON ONU entity defined in this Technical Report MUST only be managed via the OLT using OMCI and PLOAM as per G. 984
- **R-69** The G-PON ONU entity MUST allow the TR-101 access node entity to be managed by a protocol other than OMCI independent of the OLT

An entity description is given in the Figure 1 from TR-167 issue 2 [21]

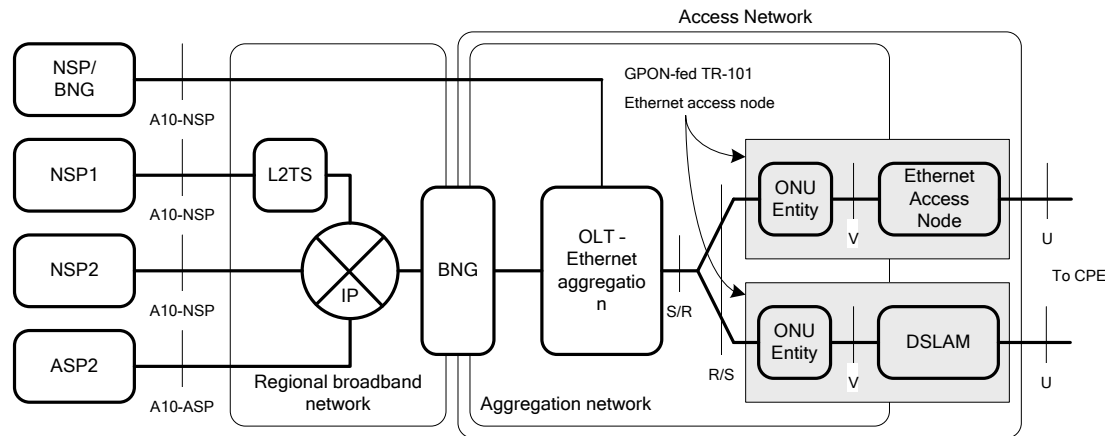

Figure 1 – Network architecture for Ethernet-based G-PON aggregation (TR-167 issue 2 [21])

4.2.3.4 TR-301 Model 2 (TR-156 Backhauling) Gfast DPU/ONU

TR-301 Model 2 (TR-156 Backhauling) DPU/ONUs are DPU devices needed for the purpose of deploying FTTdp within a TR-101 [16] and/or TR-178 [22] architecture. Per requirements from section 5.2 of TR-301 issue 2 [25], such devices implement a TR-156 [18][19][20] compliant PON technology DPU backhaul, (see also figure below).

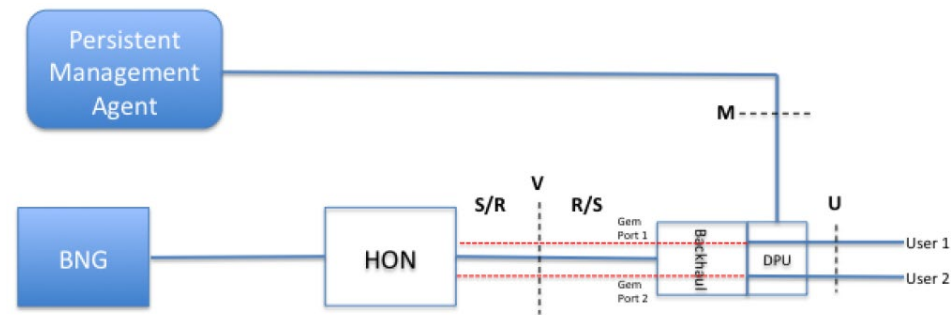

Figure 5-3 Deployment Model 2 (TR-156 Backhaul)

Source: TR-301 issue 2 [25], section 5.2

Eligibility

Only TR-301 Model 2 DPU/ONUs implementations supporting the following technologies on the uplink and downlink sides are eligible to the BBF.247 certification program:

- On the DPU/ONU uplink side: ITU-T PON Technologies G-PON [2][3] or XG-PON [4][5] or XGS-PON [10][11]
- On the DPU/ONU downlink side: G.fast [1]

As part of the Multi-Managed ONU type, and as described in §4.2.3, TR-301 Model 2 Gfast DPU/ONUs may be implementing U-interfaces virtualized either as VEIP MEs or as PPTP Ethernet UNI MEs (PPTPs). In this later context, the PPTP MEs represent the data plane hand-off point to the non-OMCI management Gfast domain(s).

Test Setup

IR-247 test setup for TR-301 Model 2 Gfast DPU/ONUs MUST include an active G.fast link from DPU/ONU to at least one G.fast end-user CPE, the system under test resulting in the combination of the G.fast DPU/ONU itself plus a G.fast CPE with an active G.fast link. It is of responsibility of the DPU/ONU manufacturer in accordance with the approved test laboratory to make a proper choice of the G.fast CPE hardware & software, as well of the G.fast link

configurations used during the certification tests. Note that different G.fast line configurations might be used for the purpose of IR-247 testing, but a same CPE MUST be used throughout the whole test coverage.

For all tests other than QoS tests, a suited G.fast profile shall be chosen to suit the need of the targeted test bitrates. It is of the applying vendor responsibility to make sure that the applied G.fast link will not limit the data rates into the DPU and will not result in packet losses.

For QoS tests, where losses and prioritization are tested, especially in the downstream, specific care to the used G.fast profile shall be taken in order to trigger congestions at the PPTP/VEIP point. A rate limitation on the G.fast link might be required to address such QoS tests in the downstream.

The G.fast line & CPE configurations used during the IR-247 tests MUST be reported by the approved test laboratory in the test report in order to allow the IR-247 tests to be reproducible. DPU/ONU vendor may rely on the Broadband Forum Gfast certification program³ and its related test plan IR-337 issue 1 [13] to choose conveniently a G.fast CPE and configurations that will ensure good interoperability and performance against their G.fast DPU/ONU implementation for the purpose of BBF.247 certification.

Covered Ports

IR-247 tests of TR-301 Model 2 Gfast DPU ONUs apply on the G.fast User Ports only, as shown in figure above (Gfast User Ports). While testing of at least one User port is mandatory, testing of the M-port (PMA Management port) of the DPU/ONU is excluded from the scope from IR-247. Testing of such management port may be addressed in future versions when the identification of the M port is made available among PPTP or VEIP Ports (for future work).

OMCI sequences and Test coverage

Identical OMCI message sequences and same test coverage as for ONU/L2 types apply to the purpose of IR-247 testing of TR-301 Model 2 Gfast DPU ONUs, with the following restrictions:

- Test case 6.6.1 *2000-Byte Frames Supported by the ONU* is not applicable for TR-301 Model 2 Gfast DPU ONUs whose System Under Test does not support 2000-byte frames size
- Test case 6.7.1 *Local setting of a registration ID at the ONU (ONU retains the Registration ID indefinitely)* does not apply to TR-301 Model 2 Gfast DPU ONUs.
- Test case 6.9.1 *Alarm synchronization* does not apply to multi-managed ONUs types (see §4.2.2 and §6.9.1)

IP parameters & packet conversion

³ <https://www.broadband-forum.org/implementation/certified-products/gfast-certified-products>

The certification program supports only TR-301 Model 2 Gfast DPU/ONU implementations that do not require provisioning of IP parameters via OMCI. All multi-managed ONU and its associated system under test MUST support and allow the implementation either of the “pure bridging” (Mode 1) or the “stripped” mode (Mode 2) as specified in section §4.2.3.

4.3 OMCI Messages

4.3.1 Reference OMCI Message Sequences

The reference OMCI message sequences required for the implementation of the IR-247 test cases are defined and available in the Broadband Forum project OD-284 : OMCI Message Sequences for TP-247 Text (<https://issues.broadband-forum.org/projects/PONTEST>).

The schemas used by the message sequences are available in the Broadband Forum project OD-283: OMCI Schema for TP-247 Text (<https://issues.broadband-forum.org/projects/PONTEST>).

There are at most 2 versions of message sequences per test case:

- one for ONUs using the PPTPEthernetUNI managed entity as the OMCI hand-off point (ONU L2 and SFP/ONU).

The text file containing this message sequence, which can be found in ID-284, is "TC_[test section number].txt, where [test section number] is derived from the test section number in the this document by replacing '.' by '_' (e.g., the OMCI sequence file for the test defined in section 6.1.1 of this document is TC_6_1_1.txt)

- when applicable, another message sequence is defined for multi-managed ONUS using the VEIP managed entity as the OMCI hand-off point. The text file containing this message sequence, which can be found in OD-284 is "TC_[test section number]_onu-rg.txt" (following the convention defined above)

The OMCI message sequences MUST not be modified, except for the purpose of OMCI messages scrambling (see section 4.3.2).

4.3.2 OMCI Scrambling process

Scrambling of the OMCI Message Sequences is performed during the execution of the TP-247 test plan in order to increase the level of ONU robustness, to ensure repeatability of the TP-247 conformance tests and minimize the risk of intentional scripting of the default OMCI sequences.

BBF.247 Certification Rules and Procedures document⁴ specifies in its Annex A - "BBF.247 Testing Process and Requirements" the utilization rules of the OMCI scrambled sequences. This Annex requires the use of the OMCI scrambler algorithm defined in Annex C of this test plan during BBF.247 certification testing.

4.3.3 Extended OMCI Format

ONUs supporting the optional Extended OMCI Format must prove their conformance to this feature whenever they advertise this support via the OMCI version reported in the Baseline Test Case 6.8.5. If the report from test case 6.8.5 shows a "Baseline & Extended OMCI Support", i.e., the reported OMCC version is within the set {"0xB0", "0xB1", "0xB2", "0xB3", "0xB4"}, ONU must apply to Profile I (Extended OMCI Messages Format) and to all related test cases (see Table 4-9). Additionally, Annex A of BBF.247 Certification Rules and Procedures document⁵ specifies additional test coverage and utilization rules of the Extended OMCI Message format throughout a test campaign to make the conformance tests even more robust.

ONU vendor wishing to skip the "Extended OMCI format" support tests & profile should explicitly advertise in the TC 6.8.5 an OMCI version limited to "Baseline Only" ("0xA" version).

4.3.4 OMCI version & Profiles Applicability

Eligibility and applicability of profiles E, F, G, H & I (see section 4.2.2) require the support by the ONU of a specific minimum OMCI version, as specified below.

ONU under test is not eligible for any of these Profiles when such a required minimum support is not met.

ONU may apply and may be eligible to any of these profiles by advertising a matching or more recent OMCI version in its OMCC version report from Test Case 6.8.5 (OMCI Version During New ONU Bring Up).

The minimum OMCI versions required for each profile E, F, G, H & I are the following:

- Profile E – Enhanced Operations
 - o all versions equal to or above 0xA2 or 0xB2 for the baseline message set testing or
 - o all versions equal to or above 0xB2 for the extended message set testing.
- Profile F – Enhanced Multicast Operations
 - o all versions equal to or above 0xA1 or 0xB1 for the baseline message set testing or
 - o all versions equal to or above 0xB1 for the extended message set testing.
- Profile G – Capacity Test Cases
 - o all versions equal to or above 0xA2 or 0xB2 for the baseline message set testing, or
 - o all versions equal to or above 0xB2 for the extended message set testing.

⁴ BBF.247 Certification Rules and Procedures document / see [BBF.247 GPON ONU Certification](#) page.

- Profile H – Monitoring Test Cases
 - o all versions equal to or above 0xA1 or 0xB1 for the baseline message set testing, or
 - o all versions equal to or above 0xB1 for the extended message set testing.
- Profile I – Extended OMCI Messages Format
 - o all versions equal to or above 0xB0 which advertise support for the extended message set and fulfilling the above OMCI version requirements for the necessary application of any of the profiles amongst (E, F, G, H).

4.4 Test Setup

4.4.1 OLT Emulator Requirements

The OLT Emulator is required to perform conformance testing of ONU devices and takes the place of the OLT. The OLT Emulator must meet the following minimum requirements. Before commencement of the testing involving an OLT Emulator, each participating ONU manufacturer will be given an opportunity to verify the OLT Emulator conformance with the GTC layer requirements to the extent required to conduct testing. It is expected that any claims of the OLT Emulator non-conformance respectively with G.984.3 [2][3] for G-PON and G.987.3 [4][5] for XG-PON and G.9807 [10][11] for XGS-PON will be investigated by an ad-hoc committee composed of the emulator vendor, the ONU vendor, and three third party GTC layer experts.

- R-1 The OLT Emulator MUST conform , within the scope of ONU activation, OMCI channel establishment, upstream bandwidth assignment, point-to-multipoint communication and encryption mechanisms, for G-PON to the G-PON Transmission Convergence layer requirements, specified in ITU-T Recommendation G.984.3 [3] (2008), for XG-PON to the XG-PON Transmission Convergence layer requirements specified in ITU-T Recommendation G.987.3 (2010) [5], for XGS-PON to the Transmission convergence layer specifications of XGS-PON from the Annex C of the ITU-T Recommendation G.9807.1 (2016) [10] .
- R-2 The OLT Emulator SHOULD recognize and handle gracefully any GTC layer features that it does not support.
- R-3 The OLT Emulator MUST support generation, transmission, and reception of OMCI messages, according to the Appendix I and II of G.988 [6][7][8].
- R-4 The OLT Emulator MUST support transmission and reception of Ethernet frames encapsulated within GEM frames.

- R-5 The OLT Emulator MUST provide a user interface that allows the tester to monitor OMCI messages and Ethernet/GEM frames and their content. This interface MUST provide a log capability of the executed test case.
- R-6 The OLT Emulator MUST support generation of PLOAM messages to activate and configure the OMCC GEM port and at least 8 other GEM ports for user traffic and provide ONU with an active upstream timeslot for any activated T-CONTs (including the one used for the OMCC).
- R-7 The OLT Emulator MUST act as the OMCI master.
- R-8 The OLT Emulator SHOULD transmit an OMCI command 3 times before declaring the ONU failed for lack of response.
- R-9 The OLT Emulator SHOULD provision allocations for T-CONTs prior to the start of the message sequence defined for each test case.
- R-10 Verification by the OLT Emulator of the consistency of the MIB held in the ONU and the MIB held in the OLT Emulator MUST be performed using either one of the following two methods on the OLT Emulator:
- via requesting a full MIB upload to the ONU under test, or
 - via performing Get Requests on Manage Entities to the ONU under test upon specific attributes of the ONU MIB.

In any of the above retrieval methods, only these parts of the ONU MIB being modified by the OLT Emulator during the test case MUST be verified for consistency.

A MIB consistency check MUST be considered as successful only when all these modified attributes have been checked consistent with the MIB held in the OLT Emulator.

- R-11 The OLT Emulator MUST be able to send and receive free-form information via a GUI to an ONU using the ONU remote debug managed entity

In respect to **R-1**:

- for G-PON ONUs, the activation process is specified in G.984.3 [3] Annex A, and encryption mechanisms in G.984.3 [3] section 12.2 (Encryption system) and G.984.3 [3] section 12.3 (Key exchange and switch-over)
- for XG-PON ONUs, the activation process is specified in G.987.3 [5] section 12 (ONU Activation) and encryption mechanisms in G.987.3 [5] section 15.5 (Data encryption key exchange and activation mechanism)
- for XGS-PON ONUs, the activation process is specified in G.9807.1 [10] Annex C section 12 (ONU Activation) and encryption mechanisms in G.987.3 [5] Annex C section 15.5 (Data encryption key exchange and activation mechanism)

4.4.2 G-PON Analyzer Requirements

The G-PON Analyzer is an optional piece of equipment, which may be included in the ODN during conformance or interoperability testing to capture and analyze the traffic present on that network.

R-12 The G-PON Analyzer **MUST NOT** alter, correct, or otherwise disturb any of the traffic present on the ODN.

R-13 The G-PON Analyzer **MUST NOT** significantly attenuate the optical signals such that the requirements of G.984.2 [2] for G-PON , G.987.2 [4] for XG-PON and G.9807.1 [10] for XGS-PON cannot be met.

4.4.3 Optical Distribution Network Requirements

The optical distribution network is outside of the scope of this test plan, however, care should be taken to ensure each optical transceiver is operating in roughly the mid-point of its dynamic range as defined respectively in G.984.2 [2] for G-PON, G.987.2 [4] for XG-PON and G.9807.1 [10] for XGS-PON; ensuring the receiver is not operating in a stressed mode, which could cause bit errors. This may be accomplished using either real fiber or an optical attenuator.

4.4.4 Unit under Test Management Interface Requirements

R-14 All configurations done on the ONU under test for the purpose of executing the test cases specified in this document **MUST** be performed using a G.988 [6][7][8] compliant management interface.

4.4.5 Selection of Random Values Used in Test Cases

Many of the test cases defined in section 6 require the tester to select distinct random values for attributes such as VID, P-bits, and GEM ports. To ensure a wide coverage of the possible value range of each attribute type, the tester must select the values in a way that provides for testing the entire value range of the attribute value being selected. For example, VID values should be selected from across the entire range of 0 – 4094. This will not only verify the flexibility of the unit under test but will also specifically address the following requirement from TR-156 [18][19][20].

- TR-156 R-8: The ONU and OLT **MUST** support all VID values from the range: 1-4094 as specified in IEEE 802.1Q, on all ports

R-15 The selection of random values for attributes used in the test cases **MUST** be performed such that the values are distributed across the possible range for each attribute. This **MUST** include the minimum, maximum and median values for the attribute. This requirement applies to the entirety of the test cases and is not intended to be a requirement for each test case.

4.4.6 ONU Conformance Test Setup

The figures below show the basic test setup used when the unit under test is an ONU. A specific test case may include an additional figure to further refine the test setup by including additional information and parameters such as, and not limited to, VLAN tags, priority bits, etc.

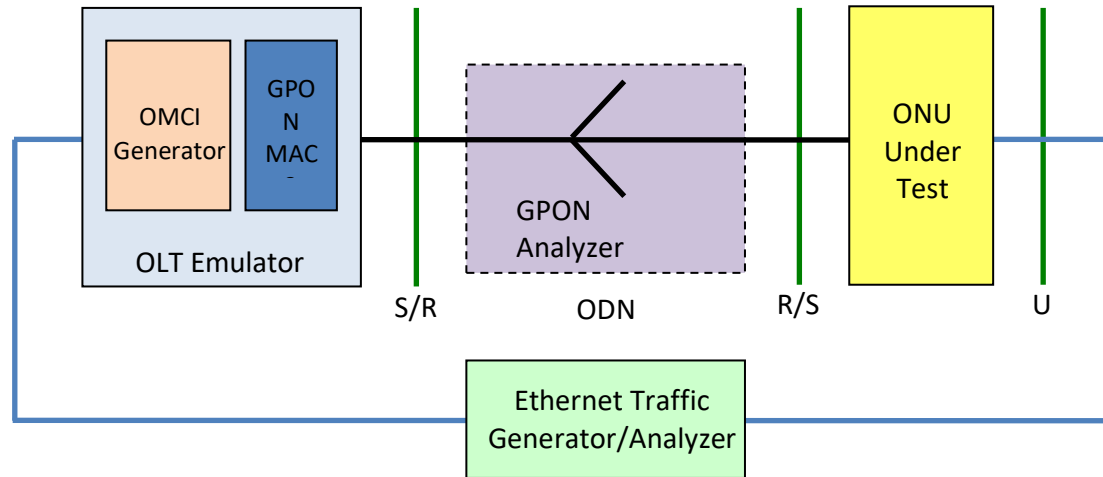

Figure 2 - Basic test setup for ONU conformance testing

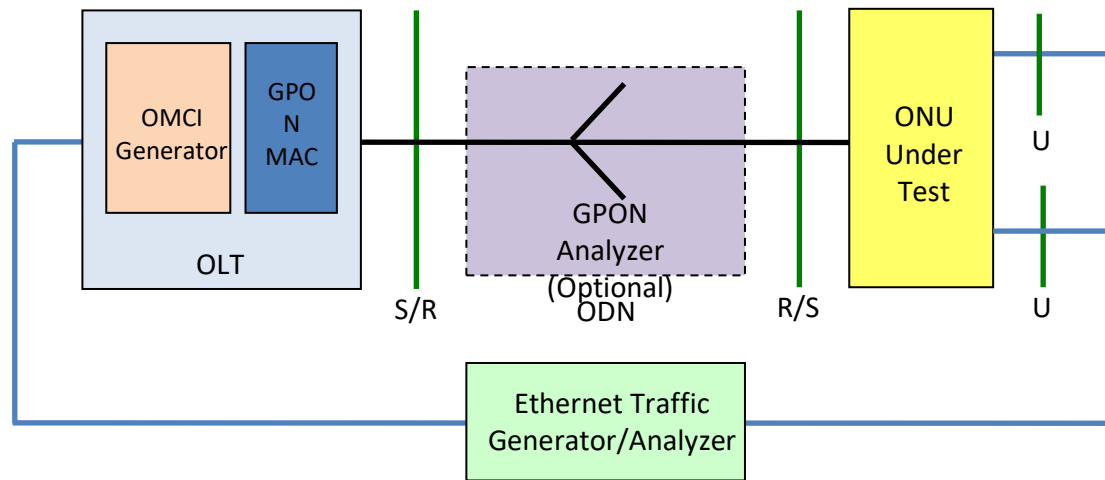

Figure 3 – Basic test setup for multiple subscriber ONU

5 Test Case Summary

Refer to tables within Section 4.2 ONU Testing Requirements.

6 ONU Conformance Tests

The following conformance tests verify:

- Compliance to the requirements of TR-156 [18][19][20].
- Compliance to the requirements of TR-280 [23] and TR-280 Amendment 1 [24].
- The implementation of TR-156 and TR-280 requirements on the ONU under test has followed the guidelines found in G.988 [6][7][8] Appendix I and II.

Each test case identifies the specific TR-156 [18][19][20] / TR-280 [23] / TR-280 Amendment 1 [24] requirements that it addresses but not the specific clauses of G.988 [6][7][8] because Appendix I and Appendix II are both written as informative rather than normative text.

The following conditions apply to all test cases unless expressly stated otherwise:

- The EtherType of all frames is 0x0800
- All test cases that involve multicast assume proxy snooping for IGMP v3 in the ONU under test.
- Each variable in test cases that contain multiple VID or P-bit variables must be set to unique values.
- In test traffic tables, the 'x' mark means the value of the field is not taken into account during the test.

6.1 Classification and Tagging

6.1.1 Single untagged U-interface

Test Name

Single untagged U-interface

Test Definition ID

ONU.6.1.1

Reference Document

BBF TR-156 [20]

ITU-T G.988 [6][7][8]

Test Type

Conformance

Test Requirement Type

Mandatory

Unit Under Test

ONU

Requirement Description**BBF TR-156:**

- **R-10** The ONU MUST support adding an S-Tag to upstream untagged traffic received from the U-interface.
- **R-11** The ONU MUST support removing an S-Tag from downstream traffic received from the OLT.
- **R-19** The ONU MUST support mapping traffic from one or more GEM Ports to a U-interface in the downstream direction.
- **R-20** The ONU MUST support adding a C-Tag or S-Tag to upstream untagged traffic.
- **R-21** The ONU MUST support removing the tag from downstream traffic.
- **R-31** The ONU MUST support mapping traffic from one or more GEM Ports to a U interface in the downstream direction.

Test Objective

The purpose of this test is to verify the ONU’s OMCI implementation, MAC bridge, and filter tables support the minimum functionality to configure a single U-interface on the ONU to pass untagged traffic across the U-interface. This test verifies both the OMCI configuration responses and support of active user traffic. The VLAN S-Tag is added to upstream traffic by the ONU before crossing the R/S-interface and removed from the downstream traffic by the ONU before crossing the U-interface.

Test Configuration

1. ONU is powered and connected to ODN
2. ONU has been activated by the OLT Emulator, has been ranged, and a GEM port for OMCI has been created as a result of ONU-ID assignment.
3. The OLT Emulator has instructed the ONU to reset its MIB to factory default values.
4. The Ethernet Traffic Generator should be configured to transmit Ethernet frames upstream with the following parameters:

Upstream Direction																								
Traffic Stream	U Interface														R/S Interface									
	UNI	MAC DA	MAC SA	Outer VLAN Tag				Inner VLAN Tag			Ethertype	IP DA	IP SA	Outer VLAN Tag				Inner VLAN Tag			GEM	T-CONT		
	Port #	Value	Value	TPID	Pbits	DEI	VID	TPID	Pbits	CFI or DEI	VID	Value	Value	Value	TPID	Pbits	DEI	VID	TPID	Pbits	CFI or DEI	VID	Port #	Number
A	1	MAC1	MAC2	n/a	n/a	n/a	n/a	n/a	n/a	n/a	n/a	x	x	x	n/a	n/a	n/a	n/a	0x88A8	0	x	SVID1	GEM1	TCONT1
B	1	MAC3	MAC4	n/a	n/a	n/a	n/a	0x8100	x	x	Any CVID	x	x	x	-	-	-	-	-	-	-	-	-	-
C	1	MAC5	MAC6	n/a	n/a	n/a	n/a	0x88A8	x	x	Any SVID	x	x	x	-	-	-	-	-	-	-	-	-	-

5. The Traffic Generator and the OLT Emulator should be configured to transmit Ethernet frames downstream with the following parameters:

Downstream Direction																							
Traffic Stream	S/R Interface														U Interface								
	MAC DA	MAC SA	Outer VLAN Tag				Inner VLAN Tag			Ethertype	IP DA	IP SA	GEM	Outer VLAN Tag				Inner VLAN Tag			UNI		
	Value	Value	TPID	Pbits	DEI	VID	TPID	Pbits	CFI or DEI	VID	Value	Value	Value	Port #	TPID	Pbits	DEI	VID	TPID	Pbits	CFI or DEI	VID	Port #
E	MAC2	MAC1	n/a	n/a	n/a	n/a	0x88A8	0	x	SVID1	x	x	x	GEM1	n/a	n/a	n/a	n/a	n/a	n/a	n/a	n/a	1

6. Only 1 user traffic class should be configured on the ONU (via defined OMCI messages below), requiring 1 GEM port (Alloc-ID, T-CONT, Port-ID).

Test Procedure

1. Select a random value for SVID1 between 1 and 4094.
2. Select unicast values for MAC1 through MAC6, which are not already in use by the ONU or other connected devices.
3. Configure the OLT Emulator to use the message sequence below to provision the ONU to support:
 - a. A single untagged U-interface
 - b. Addition/removal of the S-Tag in the upstream/downstream directions, respectively
4. Cause the OLT Emulator to request the ONU to upload its current MIB.
5. Enable any frame capture mechanisms on the OLT Emulator.

6. Cause the Ethernet Traffic Generator to transmit upstream frame(s) described in Frame-Sets A, B, C.
7. Enable any frame capture mechanisms on the Ethernet Traffic Generator.
8. Cause the Traffic Generator and the OLT Emulator to transmit downstream frame(s) described in Frame-Sets E.

OMCI Procedure Details

Refer to clause 4.3.

Pass/Fail Criteria

The test passes if the following are true, otherwise the test fails:

1. Each OMCI response message shall indicate success for the associated create or set command.
2. The uploaded ONU MIB shall be consistent with the MIB held in the OLT Emulator
3. All upstream frame(s) from Frame-Set A shall have been received as S-tagged frame(s) with the VID equal to SVID1 and TPID=0x88A8.
4. All downstream frame(s) from Frame-Set E shall have been received as untagged frame(s).
5. No upstream frame(s) from Frame-Sets B and C shall have been received (e.g., the frames are silently discarded by the ONU).

Remarks

No MAC filtering should be enabled on the ONU during these tests, or it should be configured to allow the test user traffic to pass through the ONU.

6.1.2 Single U-interface with symmetric VLAN tag translation

Test Name

Single U-interface with symmetric VLAN tag translation

Test Definition ID

ONU.6.1.2

Reference Document

BBF TR-156 [20]

ITU-T G.988 [6][7][8]

Test Type

Conformance

Test Requirement Type

Mandatory

Unit Under Test

ONU

Requirement Description

BBF TR-156:

- **R-12** The ONU MUST support unique, symmetric translation of Q-Tag VIDs received from the U-interface into S-Tag VIDs.
- **R-13** The ONU MUST support unique, symmetric translation of the S-Tag VIDs used in the downstream-tagged traffic into the Q-Tag VIDs sent to the U-interface.
- **R-19** The ONU MUST support mapping traffic from one or more GEM Ports to a U-interface in the downstream direction.
- **R-22** The ONU MUST support VID translation of the Q-Tag received from the **U** interface into the C-Tag or S-Tag for upstream-tagged traffic.
- **R-23** The ONU MUST support VID translation of the tag used in the downstream-tagged traffic into the Q-Tag sent to the **U** interface.
- **R-31** The ONU MUST support mapping traffic from one or more GEM Ports to a U interface in the downstream direction.

Test Objective

The purpose of this test is to verify the ONU's OMCI implementation, MAC bridge, and filter tables support the minimum functionality to configure a single U-interface on the ONU to pass tagged traffic across the U-interface, while translating the VID values present on the U and R/S-interfaces. This test verifies both the OMCI configuration responses and support of active user traffic. In the upstream direction, tagged traffic with VID1 received over the U-interface is transmitted over the R/S-interface with VID2. In the downstream direction, tagged traffic with VID2 received over the R/S-interface is transmitted over the U-interface with VID1. No further changes to the Ethernet frame are permitted, including changes to P-bit values, etc.

Test Configuration

1. ONU is powered and connected to ODN.
2. ONU has been activated by the OLT Emulator, has been ranged, and a GEM port for OMCI has been created as a result of ONU-ID assignment.
3. The OLT Emulator has instructed the ONU to reset its MIB to factory default values.
4. The Ethernet Traffic Generator should be configured to transmit Ethernet frames upstream with the following parameters:

Upstream Direction																								
Traffic Stream	U Interface													R/S Interface										
	UNI	MAC DA	MAC SA	Outer VLAN Tag				Inner VLAN Tag				Ethertype	IP DA	IP SA	Outer VLAN Tag				Inner VLAN Tag				GEM	T-CONT
	Port #	Value	Value	TPID	Pbits	DEI	VID	TPID	Pbits	CFI or DEI	VID	Value	Value	Value	TPID	Pbits	DEI	VID	TPID	Pbits	CFI or DEI	VID	Port #	Number
A	1	MAC1	MAC2	n/a	n/a	n/a	n/a	0x8100	CPbits1	x	CVID1	x	x	x	n/a	n/a	n/a	n/a	0x88A8	SPbits1	x	SVID2	GEM1	TCONT1
B	1	MAC1	MAC3	n/a	n/a	n/a	n/a	0x8100	x	x	Any CVID*	x	x	x	-	-	-	-	-	-	-	-	-	-
C	1	MAC1	MAC4	n/a	n/a	n/a	n/a	0x88A8	x	x	SVID1	x	x	x	-	-	-	-	-	-	-	-	-	-
D	1	MAC1	MAC5	n/a	n/a	n/a	n/a	n/a	n/a	n/a	n/a	x	x	x	-	-	-	-	-	-	-	-	-	-

5. The Traffic Generator and the OLT Emulator should be configured to transmit Ethernet frames downstream with the following parameters:

Downstream Direction																							
Traffic Stream	S/R Interface														U Interface								
	MAC DA	MAC SA	Outer VLAN Tag				Inner VLAN Tag				Ethertype	IP DA	IP SA	GEM	Outer VLAN Tag				Inner VLAN Tag				UNI
	Value	Value	TPID	Pbits	DEI	VID	TPID	Pbits	CFI or DEI	VID	Value	Value	Value	Port #	TPID	Pbits	DEI	VID	TPID	Pbits	CFI or DEI	VID	Port #
E	MAC2	MAC1	n/a	n/a	n/a	n/a	0x88A8	SPbits1	x	SVID2	x	x	x	GEM1	n/a	n/a	n/a	n/a	0x8100	CPbits1	x	CVID1	1

6. Only 1 user traffic class should be configured on the ONU (via defined OMCI messages below), requiring 1 GEM port (Alloc-ID, T-CONT, Port-ID).

Test Procedure

1. Select distinct random values for CVID1 and SVID2 between 1 and 4094, which shall not be the same value.
2. Select unicast values for MAC1 through MAC5, which are not already in use by the ONU or other connected devices.
3. Configure the OLT Emulator to use the message sequence below to provision the ONU to support:
 - a. A single U-interface, with Q-Tag CVID1.
 - b. VLAN tag translation between CVID1 and SVID2
4. Cause the OLT Emulator to request the ONU to upload its current MIB.
5. Enable any frame capture mechanisms on the OLT Emulator.
6. Cause the Ethernet Traffic Generator to transmit the upstream frame(s).
7. Enable any frame capture mechanisms on the Ethernet Traffic Generator.
8. Cause the Traffic Generator and the OLT Emulator to transmit the downstream frame(s).

OMCI Procedure Details

Refer to clause 4.3.

Pass/Fail Criteria

The test passes if the following are true, otherwise the test fails:

1. Each OMCI response message shall indicate success for the associated create or set command.
2. The uploaded ONU MIB shall be consistent with the MIB held in the OLT Emulator
3. All upstream frame(s) from Frame-Set-A received by the OLT Emulator shall be tagged with SVID2, with TPID = 0x88A8.
4. All downstream frame(s) from Frame-Set-E received by the Ethernet Traffic Generator shall be tagged with CVID1, with TPID=0x8100.
5. Any P-bit value used shall not be changed between the S/R and U-interfaces.
6. No upstream frame(s) from Frame-Sets B, C, and D shall have been received (e.g., the frames are silently discarded by the ONU).

Remarks

No MAC filtering should be enabled on the ONU during these tests, or it should be configured to allow the test user traffic to pass through the ONU.

6.1.3 Deriving P-bits as a function of received P-bits (single user port)

Test Name

Deriving P-bits as a function of received P-bits (single user port)

Test Definition Number

ONU.6.1.3

Reference Document

BBF TR-156 [20]

ITU-T G.988 [6][7][8]

Test Type

Conformance

Test Requirement Type

Mandatory

Unit Under Test

ONU

Requirement Description**BBF TR-156:**

- **R-48** The ONU MUST support deriving P-bit markings in the upstream direction based on an arbitrary combination of: user port, VID, received P-bit markings, and EtherType.

Note: Only derivation from received P-bit markings is verified by this test case.

- **Also, R-6, 7, 46, 50.**

Test Objective

Show that ONU can derive P-bit marking as a function of received P-bits.

Test Configuration

For this test, only a single user port is assumed.

ONU must be set-up with the standard L2-OCM (single user) with one upstream queue and one associated T-CONT. The intent of the test is to define two flows based on different P-bit values at the U-interface. Each flow will have an S-tag with a different P-bit value.

The U-interface and S/R-interface values for each test are shown below, along with the GEM port and T-CONT configuration.

Upstream Direction																								
Traffic Stream	U Interface														R/S Interface									
	UNI	MAC DA	MAC SA	Outer VLAN Tag				Inner VLAN Tag				Ethertype	IP DA	IP SA	Outer VLAN Tag				Inner VLAN Tag				GEM	T-CONT
	Port #	Value	Value	TPID	Pbits	DEI	VID	TPID	Pbits	CFI or DEI	VID	Value	Value	Value	TPID	Pbits	DEI	VID	TPID	Pbits	CFI or DEI	VID	Port #	Number
A	1	MAC1	MAC2	n/a	n/a	n/a	n/a	0x8100	CPbits1	x	CVID1	x	x	x	n/a	n/a	n/a	n/a	0x88A8	SPbits1	x	SVID1	GEM1	TCONT1
B	1	MAC3	MAC4	n/a	n/a	n/a	n/a	0x8100	CPbits3	x	CVID1	x	x	x	n/a	n/a	n/a	n/a	0x88A8	SPbits2	x	SVID1	GEM2	TCONT1

Traffic corresponding to each flow will produce a different P-bit marking.

Test Procedure

For each test number in the above table, inject at the U-interface tagged traffic with the specified P-bit values. Verify that specified P-bit values are observed at the S/R-interface.

OMCI Procedure Details

Refer to clause 4.3.

Pass/Fail Criteria

The test passes if the following are true, otherwise the test fails:

1. All OMCI commands have Success responses
2. A MIB upload and compare matches the MIB expected by the OLT
3. The resulting P-bit values in each of the tests above is as specified.

Remarks

- None.

6.1.4 Addition of an S-Tag in the Upstream Direction in a VBES Architecture

Test Name

Addition of an S-Tag in the Upstream Direction in a VBES Architecture

Test Definition Number

ONU.6.1.4

Reference Document

BBF TR-156 [20]

ITU-T G.988 [6][7][8]

Test Type

Conformance

Test Requirement Type

Mandatory

Unit Under Test

ONU

Requirement Description**BBF TR-156:**

- **R-34** The ONU MUST support adding an S-Tag in the upstream direction for Q-tagged, untagged, and priority-tagged frames

Test Objective

- Verify that the ONU supports adding an S-Tag in the upstream direction for Q-tagged, untagged, and priority-tagged frames

Test Configuration

1. OLT Emulator and ONU under test are powered and connected to ODN
2. ONU under test has been activated by the OLT Emulator, has been ranged, and a GEM port for OMCI has been created as a result of ONU-ID assignment.
3. The Ethernet Traffic Generator is configured to transmit tagged Ethernet frames upstream with the following parameters (Stream A):
4. The Ethernet Traffic Generator is configured to transmit priority tagged Ethernet frames upstream with the following parameters (Stream B):
5. The Ethernet Traffic Generator is configured to transmit untagged Ethernet frames upstream with the following parameters (Stream C):

Upstream Direction																								
Traffic Stream	U Interface												R/S Interface											
	UNI	MAC DA	MAC SA	Outer VLAN Tag				Inner VLAN Tag				Ethertype	IP DA	IP SA	Outer VLAN Tag				Inner VLAN Tag				GEM	T-CONT
	Port #	Value	Value	TPID	Pbits	DEI	VID	TPID	Pbits	CFI or DEI	VID	Value	Value	Value	TPID	Pbits	DEI	VID	TPID	Pbits	CFI or DEI	VID	Port #	Number
A	1	MAC1	MAC2	n/a	n/a	n/a	n/a	0x8100	x	x	CVID1	x	x	x	0x88A8	SPbits1	0	SVID1	0x8100	x	x	CVID1	GEM1	TCONT1
B	1	MAC1	MAC2	n/a	n/a	n/a	n/a	n/a	x	x	0	x	x	x	0x88A8	SPbits2	0	SVID1	n/a	x	x	0	GEM2	TCONT2
C	1	MAC1	MAC2	n/a	n/a	n/a	n/a	n/a	n/a	n/a	n/a	x	x	x	n/a	n/a	n/a	n/a	0x88A8	SPbits3	0	SVID1	GEM3	TCONT3

Test Procedure

1. Select distinct random values for CVID1, SVID1 and SPbits.
2. Select random unicast values for the MAC Addresses MAC1 and MAC2
3. Use the OLT Emulator to provision the ONU under test (via defined OMCI messages below) to support one VBES subscriber with SVID1 and SPbits1, SPbits2 SPbits3, each requiring a GEM port and T-CONT.
4. Enable any frame monitoring/capture mechanisms on the OLT Emulator.
5. Cause the Ethernet Traffic Generator/Analyzer to transmit upstream Ethernet frames with the characteristics described in the test configuration section.

OMCI Procedure Details

Refer to clause 4.3.

Pass/Fail Criteria

The test passes if the following are true, otherwise the test fails:

1. Each OMCI response message must indicate success for the associated create or set command.
2. The uploaded ONU MIB must be consistent with the MIB held in the OLT Emulator
3. All upstream C-tagged frames sent by the Ethernet tester must be received by the OLT Emulator at the S/R-interface. All frames must be error free and double-tagged with an S-tag with the VID equal to SVID1, S-Tag P-bits equal to SPbits1 and C-Tag with the VID equal to CVID1
4. All upstream priority tagged frames sent by the Ethernet tester must be received by the OLT Emulator at the S/R-interface. All frames must be error free and double-tagged with an S-tag with the VID equal to SVID1, S-Tag P-bits equal to SPbits2 and C-Tag with the VID equal to 0
5. All upstream untagged frames sent by the Ethernet tester must be received by the OLT Emulator at the S/R-interface. All frames must be error free and S-tagged with the VID equal to SVID1 and S-Tag P-bits equal to SPbits3

Remarks

- None.

6.1.5 Validation of an S-Tag in the Upstream Direction in a VBES Architecture

Test Name

Validation of an S-Tag in the Upstream Direction in a VBES Architecture

Test Definition Number

ONU.6.1.5

Reference Document

BBF TR-156 [20]

ITU-T G.988 [6][7][8]

Test Type

Conformance

Test Requirement Type

Mandatory

Unit Under Test

ONU

Requirement Description**BBF TR-156:**

- **R-35 Part 1:** The ONU MUST support validating an S-Tag in the upstream direction for S-tagged frames

Test Objective

- Verify that the ONU supports validating an S-Tag in the upstream direction for S-tagged frames

Test Configuration

1. OLT Emulator and ONU under test are powered and connected to ODN
2. ONU under test has been activated by the OLT Emulator, has been ranged, and a GEM port for OMCI has been created as a result of ONU-ID assignment.
3. The Ethernet Traffic Generator is configured to transmit tagged Ethernet frames upstream with the following parameters (Stream A)
4. The Ethernet Traffic Generator is configured to transmit double-tagged Ethernet frames upstream with the following parameters (Stream B)
5. The Ethernet Traffic Generator is configured to transmit tagged Ethernet frames upstream with the following parameters (Stream C)

Upstream Direction																								
Traffic Stream	U Interface													R/S Interface										
	UNI	MAC DA	MAC SA	Outer VLAN Tag				Inner VLAN Tag				Ethertype	IP DA	IP SA	Outer VLAN Tag				Inner VLAN Tag				GEM	T-CONT
	Port #	Value	Value	TPID	Pbits	DEI	VID	TPID	Pbits	CFI or DEI	VID	Value	Value	Value	TPID	Pbits	DEI	VID	TPID	Pbits	CFI or DEI	VID	Port #	Number
A	1	MAC1	MAC2	n/a	n/a	n/a	n/a	0x88A8	SPbits1	0	SVID1	x	x	x	n/a	n/a	n/a	n/a	0x88A8	SPbits1	0	SVID1	GEM1	TCONT1
B	1	MAC1	MAC2	0x88A8	SPbits2	0	SVID2	0x8100	x	x	CVID2	x	x	x	0x88A8	SPbits2	0	SVID2	0x8100	x	x	CVID2	GEM2	TCONT2
C	1	MAC1	MAC2	n/a	n/a	n/a	n/a	0x88A8	SPbits2	x	SVID3	x	x	x	-	-	-	-	-	-	-	-	-	-

Test Procedure

1. Select distinct random values for CVID2, SVID1, SVID2, SVID3, SPbits1, and SPbits2
2. Select distinct random values for the unicast MAC Addresses MAC1 and MAC2
3. Use the OLT Emulator to provision the ONU under test (via defined OMCI messages below) to support one VBES subscriber with two user traffic classes, requiring 2 GEM ports (Alloc-IDs, T-CONTs, Port-IDs). The ONU should be configured to validate/pass SVID1 and SVID2 only.
4. Enable any frame monitoring/capture mechanisms on the OLT Emulator.
5. Cause the Ethernet Traffic Generator/Analyzer to transmit upstream Ethernet frames with the characteristics described in the test configuration section.

OMCI Procedure Details

Refer to clause 4.3.

Pass/Fail Criteria

The test passes if the following are true, otherwise the test fails:

1. Each OMCI response message must indicate success for the associated create or set command.
2. The uploaded ONU MIB must be consistent with the MIB held in the OLT Emulator
3. Upstream frames tagged with SVID1 and SPbits1 sent by the Ethernet tester must be received error free by the OLT Emulator at the S/R-interface
4. Upstream frames double-tagged with an S-Tag with the VID equal to SVID2, S-Tag P-bits equal to SPbits2 and C-Tag with VID equal to CVID2 sent by the Ethernet tester must be received error free by the OLT Emulator at the S/R-interface
5. Upstream frames S-tagged with VID equal to SVID3 and S-Tag P-bits equal to SPbits3 sent by the Ethernet tester must not be received by the OLT Emulator at the S/R-interface. They must be silently discarded by the ONU

Remarks

- None.

6.1.6 Translation of an S-Tag in the Upstream Direction in a VBES Architecture

Test Name

Translation of an S-Tag in the Upstream Direction in a VBES Architecture

Test Definition Number

ONU.6.1.6

Reference Document

BBF TR-156 [20]

ITU-T G.988 [6][7][8]

Test Type

Conformance

Test Requirement Type

Mandatory

Unit Under Test

ONU

Requirement Description**BBF TR-156:**

- **R-35 Part 2:** The ONU MUST support translating an S-Tag in the upstream direction for S-tagged frames
- **R-42** The ONU MUST support VID translation of the S-Tag received from the U-interface into a new S- Tag for upstream double-tagged traffic

Test Objective

- Verify that the ONU supports translating an S-Tag in the upstream direction for S-tagged frames

Test Configuration

1. OLT Emulator and ONU under test are powered and connected to ODN
2. ONU under test has been activated by the OLT Emulator, has been ranged, and a GEM port for OMCI has been created as a result of ONU-ID assignment.
3. The Ethernet Traffic Generator is configured to transmit tagged Ethernet frames upstream with the following parameters (Stream A)
4. The Ethernet Traffic Generator is configured to transmit double-tagged Ethernet frames upstream with the following parameters (Stream B)
5. The Ethernet Traffic Generator is configured to transmit tagged Ethernet frames upstream with the following parameters (Stream C)

Upstream Direction																								
Traffic Stream	U Interface													R/S Interface										
	UNI	MAC DA	MAC SA	Outer VLAN Tag				Inner VLAN Tag				Ethertype	IP DA	IP SA	Outer VLAN Tag				Inner VLAN Tag				GEM	T-CONT
	Port #	Value	Value	TPID	Pbits	DEI	VID	TPID	Pbits	CFI or DEI	VID	Value	Value	Value	TPID	Pbits	DEI	VID	TPID	Pbits	CFI or DEI	VID	Port #	Number
A	1	MAC1	MAC2	n/a	n/a	n/a	n/a	0x88A8	SPbits1	x	SVID1	x	x	x	n/a	n/a	n/a	n/a	0x88A8	SPbits1	x	SVID10	GEM1	TCONT1
B	1	MAC1	MAC2	0x88A8	SPbits2	x	SVID2	0x8100	x	x	CVID2	x	x	x	0x88A8	SPbits2	x	SVID20	0x8100	x	x	CVID2	GEM2	TCONT2
C	1	MAC1	MAC2	n/a	n/a	n/a	n/a	0x88A8	SPbits3	x	SVID3	x	x	x	-	-	-	-	-	-	-	-	-	-

Note: SVID3 and SPbits3 must not be configured as part of the VBES Service

Test Procedure

1. Select distinct random values for CVID2, SVID1, SVID2, SVID3, SVID10, SVID20, SPbits1, SPbits2 and SPbits3
2. Select distinct random values for the unicast MAC Addresses MAC1 and MAC2
3. Use the OLT Emulator to provision the ONU under test (via defined OMCI messages below) to support one VBES subscriber with two user traffic classes, requiring 2 GEM ports (Alloc-IDs, T-CONTs, Port-IDs).
4. Use the OLT Emulator to provision the ONU under test (via defined OMCI messages below) to translate SVID1 and SPbits1 to SVID10 and SPbits1 and to translate SVID2 and SPbits2 to SVID20 and SPbits2
5. Enable any frame monitoring/capture mechanisms on the OLT Emulator.
6. Cause the Ethernet Traffic Generator/Analyzer to transmit upstream Ethernet frames with the characteristics described in the test configuration section.

OMCI Procedure Details

Refer to clause 4.3.

Pass/Fail Criteria

The test passes if the following are true, otherwise the test fails:

1. Each OMCI response message must indicate success for the associated create or set command.
2. The uploaded ONU MIB must be consistent with the MIB held in the OLT Emulator
3. Upstream frames S-tagged with the VID equal to SVID1 and S-Tag P-bits equal to SPbits1 sent by the Ethernet tester must be received error free, S-Tagged with SVID10 and SPbits1 by the OLT Emulator at the S/R-interface
4. Upstream frames double-tagged with the VID equal to SVID2, S-Tag P-bits equal to SPbits2 and C-Tag equal to CVID2 sent by the Ethernet tester must be received error free, S-Tagged with SVID20, S-Tag P-bits equal to SPbits2 and C-Tag equal to CVID2 by the OLT Emulator at the S/R-interface

5. Upstream frames S-tagged with the VID equal to SVID3 and S-Tag P-bits equal to SPbits3 sent by the Ethernet tester must not be received by the OLT Emulator at the S/R-interface. They must be silently discarded by the ONU

Remarks

- None.

6.1.7 Removal of an S-Tag in the Downstream Direction in a VBES Architecture

Test Name

Removal of an S-Tag in the Downstream Direction in a VBES Architecture

Test Definition Number

ONU.6.1.7

Reference Document

BBF TR-156 [20]

ITU-T G.988 [6][7][8]

Test Type

Conformance

Test Requirement Type

Mandatory

Unit Under Test

ONU

Requirement Description

BBF TR-156:

- **R-36** The ONU MUST support removing an S-Tag in the downstream direction

Test Objective

- Verify that the ONU supports removing an S-Tag in the downstream direction

Test Configuration

1. OLT Emulator and ONU under test are powered and connected to ODN
2. ONU under test has been activated by the OLT Emulator, has been ranged, and a GEM port for OMCI has been created as a result of ONU-ID assignment.
3. The Traffic Generator and the OLT Emulator are configured to transmit double-tagged Ethernet frames downstream with the following parameters (Stream A)
4. The Traffic Generator and the OLT Emulator are configured to transmit double-tagged Ethernet frames downstream with the following parameters (Stream B)
5. The Traffic Generator and the OLT Emulator are configured to transmit tagged Ethernet frames downstream with the following parameters (Stream C)

Downstream Direction																							
Traffic Stream	S/R Interface														U Interface								
	MAC DA	MAC SA	Outer VLAN Tag				Inner VLAN Tag				Ethertype	IP DA	IP SA	GEM	Outer VLAN Tag				Inner VLAN Tag				UNI
	Value	Value	TPID	Pbits	DEI	VID	TPID	Pbits	CFI or DEI	VID	Value	Value	Value	Port #	TPID	Pbits	DEI	VID	TPID	Pbits	CFI or DEI	VID	Port #
A	MAC1	MAC2	0x88A8	SPbits1	0	SVID1	0x8100	x	x	CVID1	x	x	x	GEM1	n/a	n/a	n/a	n/a	0x8100	x	x	CVID1	1
B	MAC1	MAC2	0x88A8	SPbits2	0	SVID1	0x8100	x	x	0	x	x	x	GEM2	n/a	n/a	n/a	n/a	0x8100	x	x	0	1
C	MAC1	MAC2	n/a	n/a	n/a	n/a	0x88A8	SPbits3	0	SVID1	x	x	x	GEM3	n/a	n/a	n/a	n/a	n/a	n/a	n/a	n/a	1

Test Procedure

1. Select distinct random values for CVID1, SVID1, SPbits1, SPbits2, and SPbits3
2. Select distinct random values for the unicast MAC Addresses MAC1 and MAC2
3. Use the OLT Emulator to provision the ONU under test (via defined OMCI messages below) to support one VBES subscriber with three user traffic classes, requiring 3 GEM ports (Alloc-IDs, T-CONTs, Port-IDs).
4. Enable any frame monitoring/capture mechanisms on the Ethernet Traffic Generator/Analyzer.
5. Cause the Traffic Generator and the OLT Emulator to transmit downstream traffic with the characteristics described in the test configuration section.

OMCI Procedure Details

Refer to clause 4.3.

Pass/Fail Criteria

The test passes if the following are true, otherwise the test fails:

1. Each OMCI response message must indicate success for the associated create or set command.
2. The uploaded ONU MIB must be consistent with the MIB held in the OLT Emulator
3. All downstream double-tagged frames sent by the Traffic Generator and the OLT Emulator with an S-Tag with a VID equal to SVID1, S-Tag P-bits equal to SPbits1 and C-Tag equal to CVID1 must be received C-tagged only with a VID value equal to CVID1 by the Ethernet Traffic Emulator/Generator at the U-interface
4. All downstream double-tagged frames sent by the Traffic Generator and the OLT Emulator with an S-Tag with a VID equal to SVID1, S-Tag P-bits equal to SPbits2 and C-Tag (priority tagged) must be received Priority-tagged only with a VID value equal to 0 by the Ethernet Traffic Emulator/Generator at the U-interface
5. All downstream S-tagged frames sent by the Traffic Generator and the OLT Emulator with an S-Tag with a VID equal to SVID1 and S-Tag P-bits equal to SPbits3 must be received untagged by the Ethernet Traffic Emulator/Generator at the U-interface

Remarks

- None.

6.1.8 Translation of an S-Tag in the Downstream Direction in a VBES Architecture

Test Name

Translation of an S-Tag in the Downstream Direction in a VBES Architecture

Test Definition Number

ONU.6.1.8

Reference Document

BBF TR-156 [20]

ITU-T G.988 [6][7][8]

Test Type

Conformance

Test Requirement Type

Mandatory

Unit Under Test

ONU

Requirement Description

BBF TR-156:

- **R-43** The ONU MUST support VID translation of the S-Tag received from the G-PON interface into a new S-Tag for downstream double-tagged traffic sent to the U-interface

Test Objective

- Verify that the ONU supports VID translation of the S-Tag received from the G-PON interface into a new S-Tag for downstream double-tagged traffic sent to the U-interface

Test Configuration

The same test configuration as used for 6.1.6 is used for this test but with the traffic running in the downstream direction:

1. OLT Emulator and ONU under test are powered and connected to ODN
2. ONU under test has been activated by the OLT Emulator, has been ranged, and a GEM port for OMCI has been created as a result of ONU-ID assignment.
3. The Ethernet Traffic Generator is configured to transmit double-tagged Ethernet frames downstream with the following parameters (Stream A)
4. The Ethernet Traffic Generator is configured to transmit double-tagged Ethernet frames downstream with the following parameters (Stream B)

Downstream Direction																							
Traffic Stream	S/R Interface													U Interface									
	MAC DA	MAC SA	Outer VLAN Tag				Inner VLAN Tag				Ethertype	IP DA	IP SA	GEM	Outer VLAN Tag				Inner VLAN Tag				UNI
	Value	Value	TPID	Pbits	DEI	VID	TPID	Pbits	CFI or DEI	VID	Value	Value	Value	Port #	TPID	Pbits	DEI	VID	TPID	Pbits	CFI or DEI	VID	Port #
A	MAC1	MAC2	0x88A8	SPbits1	0	SVID10	0x8100	x	x	CVID1	x	x	x	GEM1	0x88A8	SPbits1	0	SVID1	0x8100	x	x	CVID1	1
B	MAC1	MAC2	0x88A8	SPbits2	0	SVID20	0x8100	x	x	CVID2	x	x	x	GEM2	0x88A8	SPbits2	0	SVID2	0x8100	x	x	CVID2	1

Test Procedure

1. Select distinct random values for CVID1 CVID2, SVID1, SVID2, SVID10, SVID20, SPbits1, and SPbits2
2. Select distinct random values for the unicast MAC Addresses MAC1 and MAC2
3. Use the OLT Emulator to provision the ONU under test (via defined OMCI messages below) to support one VBES subscriber with two user traffic classes, requiring 2 GEM ports (Alloc-IDs, T-CONTs, Port-IDs).
4. Use the OLT Emulator to provision the ONU under test (via defined OMCI messages below) to translate SVID1 and SPbits1 to SVID10 and SPbits1 and to translate SVID2 and SPbits2 to SVID20 and SPbits2
5. Enable any frame monitoring/capture mechanisms on the OLT Emulator.
6. Cause the Ethernet Traffic Generator/Analyzer to transmit downstream Ethernet frames with the characteristics described in the test configuration section.

OMCI Procedure Details

Refer to clause 4.3.

Pass/Fail Criteria

The test passes if the following are true, otherwise the test fails:

1. Each OMCI response message must indicate success for the associated create or set command.
2. The uploaded ONU MIB must be consistent with the MIB held in the OLT Emulator
3. Downstream double-tagged frames must appear at the U-interface with S-Tags translated to match the stated U-interface configuration.

Remarks

- None.

6.1.9 Test Case Reserved For Future Use

6.1.10 Deriving P-bits as a function of received VID (single user port)

Test Name

Deriving P-bits as a function of received VID (single user port)

Test Definition Number

ONU.6.1.10

Reference Document

BBF TR-156 [20]

ITU-T G.988 [6][7][8]

Test Type

Conformance

Test Requirement Type

Mandatory

Unit Under Test

ONU

Requirement Description**BBF TR-156:**

- **R-48** The ONU MUST support deriving P-bit markings in the upstream direction based on an arbitrary combination of: user port, VID, received P-bit markings, and EtherType.
- **Also, R-6, 7, 50.**

Test Objective

Show that ONU can derive P-bit marking as a function of received VID.

Test Configuration

For this test, only a single user port is assumed.

1. ONU must be set-up with the standard L2 OCM (single user) with three upstream queues and two associated T-CONTs. The intent of the test is to define two flows based on 2 different VID values at the U-interface. Each flow will have an S-tag added with a specified P-bit value.
2. The U-interface and S/R-interface values for each test are shown below, along with the GEM port and T-CONT configuration.

Upstream Direction																								
Traffic Stream	U Interface													R/S Interface										
	UNI	MAC DA	MAC SA	Outer VLAN Tag				Inner VLAN Tag				Ethertype	IP DA	IP SA	Outer VLAN Tag				Inner VLAN Tag				GEM	T-CONT
	Port #	Value	Value	TPID	Pbits	DEI	VID	TPID	Pbits	CFI or DEI	VID	Value	Value	Value	TPID	Pbits	DEI	VID	TPID	Pbits	CFI or DEI	VID	Port #	Number
A	1	MAC1	MAC2	n/a	n/a	n/a	n/a	0x8100	x	x	CVID1	x	x	x	0x88A8	SPbits1	x	SVID1	0x8100	x	x	CVID1	GEM1	TCONT1
B	1	MAC1	MAC2	n/a	n/a	n/a	n/a	0x8100	x	x	CVID2	x	x	x	0x88A8	SPbits2	x	SVID1	0x8100	x	x	CVID2	GEM2	TCONT2

Traffic corresponding to each flow will produce a different P-bit marking.

Test Procedure

For each test number in the above table, inject at the U-interface tagged traffic with the specified VID values. Verify that specified P-bit values are observed at the S/R-interface.

OMCI Procedure Details

Refer to clause 4.3.

Pass/Fail Criteria

The test passes if the following are true, otherwise the test fails:

1. All OMCI commands have Success responses
2. A MIB upload and compare matches the MIB expected by the OLT
3. The resulting P-bit values in each of the tests above is as specified.

Remarks

- None.

6.1.11 Deriving P-bits as a function of received Ethertype (single user port)

Test Name

Deriving P-bits as a function of received Ethertype (single user port)

Test Definition Number

ONU.6.1.11

Reference Document

BBF TR-156 [20]

ITU-T G.988 [6][7][8]

Test Type

Conformance

Test Requirement Type

Mandatory

Unit Under Test

ONU

Requirement Description**BBF TR-156:**

- **R-48** The ONU MUST support deriving P-bit markings in the upstream direction based on an arbitrary combination of: user port, VID, received P-bit markings, and EtherType.
- **Also, R-6, 7, 50.**

Test Objective

Show that ONU can derive P-bit marking as a function of received Ethertype.

Test Configuration

For this test, only a single user port is assumed.

1. ONU must be set-up with the standard L2 OCM (single user) with two upstream queues and two associated T-CONTs. The intent of the test is to define two flows based on different Ethertype values at the U-interface. (Ethertype=0x8863 is PPPoE; Ethertype=0x0800 is IPoE) Each flow will have an S-tag added with P-bit value different from the other flow.

2. The U-interface and S/R-interface values for each test are shown below, along with the GEM port and T-CONT configuration.

Upstream Direction																								
Traffic Stream	U Interface													R/S Interface										
	UNI	MAC DA	MAC SA	Outer VLAN Tag				Inner VLAN Tag				Ethertype	IP DA	IP SA	Outer VLAN Tag				Inner VLAN Tag				GEM	T-CONT
	Port #	Value	Value	TPID	Pbits	DEI	VID	TPID	Pbits	CFI or DEI	VID	Value	Value	Value	TPID	Pbits	DEI	VID	TPID	Pbits	CFI or DEI	VID	Port #	Number
A	1	MAC1	MAC2	n/a	n/a	n/a	n/a	0x8100	CPbits1	x	CVID1	0x8863	x	x	0x88A8	SPbits1	x	SVID1	0x8100	CPbits1	x	CVID1	GEM1	TCONT1
B	1	MAC1	MAC2	n/a	n/a	n/a	n/a	0x8100	CPbits1	x	CVID1	0x0800	x	x	0x88A8	SPbits2	x	SVID1	0x8100	CPbits1	x	CVID1	GEM2	TCONT2

Traffic corresponding to each flow will produce a different P-bit marking.

Test Procedure

For each test number in the above table, inject at the U-interface tagged traffic with the specified Ethertype values. Verify that specified P-bit values are observed at the S/R-interface.

OMCI Procedure Details

Refer to clause 4.3.

Pass/Fail Criteria

The test passes if the following are true, otherwise the test fails:

1. All OMCI commands have Success responses
2. A MIB upload and compare matches the MIB expected by the OLT
3. The resulting P-bit values in each of the tests above is as specified.

Remarks

- None.

6.1.12 Deriving P-bits as a function of received user port

Test Name

Deriving P-bits as a function of received user port

Test Definition Number

ONU.6.1.12

Reference Document

BBF TR-156 [20]

ITU-T G.988 [6][7][8]

Test Type

Conformance

Test Requirement Type

Conditionally Mandatory (if ONT has multiple user ports)

Unit Under Test

ONU

Requirement Description

TR-156

- **R-48** The ONU MUST support deriving P-bit markings in the upstream direction based on an arbitrary combination of: user port, VID, received P-bit markings, and EtherType.
- **Also, R-6, 7, 50.**

Test Objective

Show that ONU can derive P-bit marking as a function of received user port.

Test Configuration

For this test, multiple user ports are assumed. Therefore, multiple bridges must be provisioned in the OMCI model.

1. ONU must be set-up with the standard L2 OCM (multiple user port) with two upstream queues and two associated T-CONTs. The intent of the test is to define two streams per user ports. Each stream will have an S-tag added with P-bit value based on user port.

2. The U-interface and S/R interface values for each test are shown below, along with the GEM port and T-CONT configuration.

Upstream Direction																								
Traffic Stream	U Interface												R/S Interface											
	UNI	MAC DA	MAC SA	Outer VLAN Tag				Inner VLAN Tag				Ethertype	IP DA	IP SA	Outer VLAN Tag				Inner VLAN Tag				GEM	T-CONT
	Port #	Value	Value	TPID	Pbits	DEI	VID	TPID	Pbits	CFI or DEI	VID	Value	Value	Value	TPID	Pbits	DEI	VID	TPID	Pbits	CFI or DEI	VID	Port #	Number
A	1	MAC1	MAC2	n/a	n/a	n/a	n/a	0x8100	CPbits1	x	CVID1	x	x	x	0x88A8	SPbits1	0	SVID1	0x8100	CPbits1	x	CVID1	GEM1	TCONT1
B	2	MAC3	MAC4	n/a	n/a	n/a	n/a	0x8100	CPbits1	x	CVID1	x	x	x	0x88A8	SPbits2	0	SVID1	0x8100	CPbits1	x	CVID1	GEM2	TCONT2
C	1	MAC1	MAC2	n/a	n/a	n/a	n/a	n/a	n/a	n/a	n/a	x	x	x	n/a	n/a	n/a	n/a	0x88A8	SPbits1	x	SVID1	GEM1	TCONT1
D	2	MAC3	MAC4	n/a	n/a	n/a	n/a	n/a	n/a	n/a	n/a	x	x	x	n/a	n/a	n/a	n/a	0x88A8	SPbits2	x	SVID1	GEM2	TCONT2

Traffic corresponding to each flow will produce a different P-bit marking.

Test Procedure

1. select distinct random values for CVID1, SVID1, CPbit1, SPbit1, SPbit2
2. Configure L2 OCM for the test sequence number 1
3. Inject flow A to D at the U-Interface
4. Use the G-PON analyser or OLT Emulator, to verify that P-bits are correctly assigned as a function of received user port

OMCI Procedure Details

Refer to clause 4.3.

Pass/Fail Criteria

The test passes if all of following are true:

1. All OMCI commands have Success responses
2. A MIB upload and compare matches the MIB expected by the OLT
3. The resulting P-bit values in each of the tests above is as specified (at step 4).

Otherwise the test fails.

Remarks

- None.

6.1.13 VID Support for Untagged Frames (N:1 VLAN or 1:1 VLAN Architecture Single-Tagged at the V Interface)

Test Name

VID Support for Untagged Frames (N:1 VLAN or 1:1 VLAN Architecture Single-Tagged at the V Interface)

Test Definition Number

ONU.6.1.13

Reference Document

BBF TR-156 [20]

ITU-T G.988 [6][7][8]

Test Type

Conformance

Test Requirement Type

Mandatory

Unit Under Test

ONU

Requirement Description**BBF TR-156:**

- **R-9** The ONU MUST support setting VID for untagged and priority tagged frames in the upstream direction based on EtherType, except on VLANs used for Business Ethernet Services.

Test Objective

Verify that the ONU supports setting VID for untagged frames in the upstream direction based on EtherType, for N:1 VLAN or 1:1 VLAN single-tagged at the V-interface

Test Configuration

1. OLT Emulator and ONU under test are powered and connected to ODN
2. ONU under test has been activated by the OLT Emulator, has been ranged, and a GEM port for OMCI has been created as a result of ONU-ID assignment.
3. The Ethernet Traffic Generator is configured to transmit untagged Ethernet frames upstream with the following parameters (Stream A - IPv4)
4. The Ethernet Traffic Generator is configured to transmit untagged Ethernet frames upstream with the following parameters (Stream B - PPPoE Discovery)

5. The Ethernet Traffic Generator is configured to transmit untagged Ethernet frames upstream with the following parameters (Stream C - PPPoE Session)
6. The Ethernet Traffic Generator is configured to transmit untagged Ethernet frames upstream with the following parameters (Stream D - ARP)

Upstream Direction																								
Traffic Stream	U Interface												R/S Interface											
	UNI	MAC DA	MAC SA	Outer VLAN Tag				Inner VLAN Tag				Ethertype	IP DA	IP SA	Outer VLAN Tag				Inner VLAN Tag				GEM	T-CONT
	Port #	Value	Value	TPID	Pbits	DEI	VID	TPID	Pbits	CFI or DEI	VID	Value	Value	Value	TPID	Pbits	DEI	VID	TPID	Pbits	CFI or DEI	VID	Port #	Number
A	1	MAC1	MAC2	n/a	n/a	n/a	n/a	n/a	n/a	n/a	n/a	0x0800	x	x	n/a	n/a	n/a	n/a	0x88A8	SPbits1	x	SVID1	GEM1	TCONT1
B	1	MAC3	MAC4	n/a	n/a	n/a	n/a	n/a	n/a	n/a	n/a	0x8863	x	x	n/a	n/a	n/a	n/a	0x88A8	SPbits2	x	SVID2	GEM1	TCONT1
C	1	MAC5	MAC6	n/a	n/a	n/a	n/a	n/a	n/a	n/a	n/a	0x8864	n/a	n/a	n/a	n/a	n/a	n/a	0x88A8	SPbits2	x	SVID2	GEM1	TCONT1
D	1	MAC7	MAC8	n/a	n/a	n/a	n/a	n/a	n/a	n/a	n/a	0x0806	n/a	n/a	n/a	n/a	n/a	n/a	0x88A8	SPbits1	x	SVID1	GEM1	TCONT1

7. For N:1 VLAN or 1:1 VLAN single-tagged at the V-interface, an S-Tag is added at the ONU for upstream traffic, as defined in the table above

Test Procedure

1. Select distinct random values for SVID1, SVID2, SPbits1, and SPbits2.
2. Select distinct random values for the unicast MAC Addresses MAC1 to MAC8
3. Use the OLT Emulator to provision the ONU under test (via defined OMCI messages below) to support one N:1 VLAN or one 1:1 VLAN (single-tagged at the V-interface) subscriber with one user traffic class, requiring 1 GEM port (Alloc-ID, T-CONT, Port-ID).
4. Enable any frame monitoring/capture mechanisms on the OLT Emulator.
5. Cause the Ethernet Traffic Generator/Analyzer to transmit upstream Ethernet frames with the characteristics described in the test configuration section.

OMCI Procedure Details

Refer to clause 4.3.

Pass/Fail Criteria

The test passes if the following are true, otherwise the test fails:

1. Each OMCI response message must indicate success for the associated create or set command.
2. The uploaded ONU MIB must be consistent with the MIB held in the OLT Emulator.
3. All upstream frames (from streams A and D) received by the OLT Emulator at the S/R-interface must be error free, with an S-Tag with a VID equal to SVID1 and S-Tag P-bits equal to SPbits1.
4. All upstream frames (from streams B and C) received by the OLT Emulator at the S/R-interface must be error free, with an S-Tag with a VID equal to SVID2 and S-Tag P-bits equal to SPbits2.

Remarks

For more details see R-26/TR-101 [16] and R-27/TR-101 [16].

6.1.14 VID Support for Untagged Frames (1:1 VLAN Architecture Double-Tagged at the V Interface)

Test Name

VID Support for Untagged Frames (1:1 VLAN Architecture Double-Tagged at the V Interface)

Test Definition Number

ONU.6.1.14

Reference Document

BBF TR-156 [20]

ITU-T G.988 [6][7][8]

Test Type

Conformance

Test Requirement Type

Mandatory

Unit Under Test

ONU

Requirement Description**BBF TR-156:**

- **R9:** The ONU MUST support setting VID for untagged and priority tagged frames in the upstream direction based on EtherType, except on VLANs used for Business Ethernet Services.

Test Objective

Verify that the ONU supports setting VID for untagged frames in the upstream direction based on EtherType, for 1:1 VLAN double-tagged at the V-interface

Test Configuration

1. OLT Emulator and ONU under test are powered and connected to ODN
2. ONU under test has been activated by the OLT Emulator, has been ranged, and a GEM port for OMCI has been created as a result of ONU-ID assignment.
3. The Ethernet Traffic Generator is configured to transmit untagged Ethernet frames upstream with the following parameters (Stream A - IPv4)
4. The Ethernet Traffic Generator is configured to transmit untagged Ethernet frames upstream with the following parameters (Stream B – PPPoE Discovery)

- The Ethernet Traffic Generator is configured to transmit untagged Ethernet frames upstream with the following parameters (Stream C – PPPoE Session)
- The Ethernet Traffic Generator is configured to transmit untagged Ethernet frames upstream with the following parameters (Stream D – ARP)

Upstream Direction																								
Traffic Stream	U Interface												R/S Interface											
	UNI	MAC DA	MAC SA	Outer VLAN Tag				Inner VLAN Tag				Ethertype	IP DA	IP SA	Outer VLAN Tag				Inner VLAN Tag				GEM	T-CONT
	Port #	Value	Value	TPID	Pbits	DEI	VID	TPID	Pbits	CFI or DEI	VID	Value	Value	Value	TPID	Pbits	DEI	VID	TPID	Pbits	CFI or DEI	VID	Port #	Number
A	1	MAC1	MAC2	n/a	n/a	n/a	n/a	n/a	n/a	n/a	n/a	0x0800	x	x	n/a	n/a	n/a	n/a	0x8100	CPbits1	x	CVID1	GEM1	TCONT1
B	1	MAC3	MAC4	n/a	n/a	n/a	n/a	n/a	n/a	n/a	n/a	0x8863	x	x	n/a	n/a	n/a	n/a	0x8100	CPbits2	x	CVID2	GEM1	TCONT1
C	1	MAC5	MAC6	n/a	n/a	n/a	n/a	n/a	n/a	n/a	n/a	0x8864	n/a	n/a	n/a	n/a	n/a	n/a	0x8100	CPbits2	x	CVID2	GEM1	TCONT1
D	1	MAC7	MAC8	n/a	n/a	n/a	n/a	n/a	n/a	n/a	n/a	0x0806	n/a	n/a	n/a	n/a	n/a	n/a	0x8100	CPbits1	x	CVID1	GEM1	TCONT1

- For 1:1 VLAN double-tagged at the V-interface, a C-Tag is added at the ONU for upstream traffic, as defined in the table above.

Test Procedure

- Select distinct random values for CVID1, CVID2, CPbits1 and CPbits2
- Select distinct random values for the unicast MAC Addresses MAC1 to MAC8
- Use the OLT Emulator to provision the ONU under test (via defined OMCI messages below) to support one 1:1 VLAN (double-tagged at the V-interface) subscriber with one user traffic class, requiring 1 GEM port (Alloc-ID, T-CONT, Port-ID).
- Enable any frame monitoring/capture mechanisms on the OLT Emulator.
- Cause the Ethernet Traffic Generator/Analyzer to transmit upstream Ethernet frames with the characteristics described in the test configuration section.

OMCI Procedure Details

Refer to clause 4.3.

Pass/Fail Criteria

The test passes if the following are true, otherwise the test fails:

- Each OMCI response message must indicate success for the associated create or set command.
- The uploaded ONU MIB must be consistent with the MIB held in the OLT Emulator
- All upstream frames (from streams A and D) received by the OLT Emulator at the S/R-interface must be error free, with a C-Tag with a VID equal to CVID1 and C-Tag P-bits equal to CPbits1
- All upstream frames (from streams B and C) received by the OLT Emulator at the S/R-interface must be error free, with a C-Tag with a VID equal to CVID2 and C-Tag P-bits equal to CPbits2

Remarks

For more details see R-26/TR-101 [16] and R-27/TR-101 [16].

6.1.15 VID Support for Priority Tagged Frames with Priority Preservation (N:1 VLAN or 1:1 VLAN Architecture Single-Tagged at the V Interface)

Test Name

VID Support for Priority Tagged Frames with Priority Preservation (N:1 VLAN or 1:1 VLAN Architecture Single-Tagged at the V Interface)

Test Definition Number

ONU.6.1.15

Reference Document

BBF TR-156 [20]

BBF TR-101 [16]

ITU-T G.988 [6][7][8]

Test Type

Conformance

Test Requirement Type

Mandatory

Unit Under Test

ONU

Requirement Description**BBF TR-156:**

- **R-9** The ONU MUST support setting VID for untagged and priority-tagged frames in the upstream direction based on EtherType, except on VLANs used for Business Ethernet Services.

BBF TR-101:

- For each port configured as 'untagged or priority-tagged' or 'admit all', the Access Node MUST allow the operator to configure whether it should copy the priority marking of the received upstream priority-tagged frame to the S-tag (and C-tag, if applicable) or whether it should override it using an ingress to egress priority mapping

Test Objective

Verify that the ONU supports setting VID for priority-tagged frames in the upstream direction based on EtherType, for N:1 VLAN or 1:1 VLAN single-tagged at the V-interface, with priority preservation

Test Configuration

1. OLT Emulator and ONU under test are powered and connected to ODN

2. ONU under test has been activated by the OLT Emulator, has been ranged, and a GEM port for OMCI has been created as a result of ONU-ID assignment.
3. The Ethernet Traffic Generator is configured to transmit priority tagged Ethernet frames upstream with the following parameters

Upstream Direction																								
Traffic Stream	U Interface													R/S Interface										
	UNI	MAC DA	MAC SA	Outer VLAN Tag				Inner VLAN Tag				Ethertype	IP DA	IP SA	Outer VLAN Tag				Inner VLAN Tag				GEM	T-CONT
	Port #	Value	Value	TPID	Pbits	DEI	VID	TPID	Pbits	CFI or DEI	VID	Value	Value	Value	TPID	Pbits	DEI	VID	TPID	Pbits	CFI or DEI	VID	Port #	Number
A	1	MAC1	MAC2	n/a	n/a	n/a	n/a	0x8100	CPbits1	x	0	0x0800	x	x	n/a	n/a	n/a	n/a	0x88A8	SPbits1	x	SVID1	GEM1	TCONT1
B	1	MAC3	MAC4	n/a	n/a	n/a	n/a	0x8100	CPbits2	x	0	0x8863	x	x	n/a	n/a	n/a	n/a	0x88A8	SPbits2	x	SVID2	GEM1	TCONT1
C	1	MAC5	MAC6	n/a	n/a	n/a	n/a	0x8100	CPbits2	x	0	0x8864	n/a	n/a	n/a	n/a	n/a	n/a	0x88A8	SPbits2	x	SVID2	GEM1	TCONT1
D	1	MAC7	MAC8	n/a	n/a	n/a	n/a	0x8100	CPbits4	x	0	0x0806	n/a	n/a	n/a	n/a	n/a	n/a	0x88A8	SPbits4	x	SVID1	GEM1	TCONT1

4. For N:1 VLAN or 1:1 VLAN single-tagged at the V-interface, an S-Tag is added at the ONU for upstream traffic, as defined in the table above

Test Procedure

1. Select distinct random values for CPbits1, CPbits2, CPbits4, SVID1 and SVID2 (SPbitsn must be equal to CPbitsn)
2. Select distinct random values for the unicast MAC Addresses MAC1 and MAC2
3. Use the OLT Emulator to provision the ONU under test (via defined OMCI messages below) to support one N:1 VLAN or one 1:1 VLAN (single-tagged at the V-interface) subscriber with one user traffic class, requiring 1 GEM port (Alloc-ID, T-CONT, Port-ID).
4. Enable any frame monitoring/capture mechanisms on the OLT Emulator.
5. Cause the Ethernet Traffic Generator/Analyzer to transmit upstream Ethernet frames with the characteristics described in the test configuration section.

OMCI Procedure Details

Refer to clause 4.3.

Pass/Fail Criteria

The test passes if the following are true, otherwise the test fails:

1. Each OMCI response message must indicate success for the associated create or set command.
2. The uploaded ONU MIB must be consistent with the MIB held in the OLT Emulator
3. All upstream frames received by the OLT Emulator at the S/R-interface must be error free, with an S-Tag with a VID equal to SVID1 or SVID2 and SPbits values equal to the CPbits values.
4. SVID2 tagged frames must contain PPPoE Ethertypes.

Remarks

For more details see R-26/TR-101 [16] and R-27/TR-101 [16].

6.1.16 VID Support for Priority Tagged Frames without Priority Preservation (N:1 VLAN or 1:1 VLAN Architecture Single-Tagged at the V Interface)

Test Name

VID Support for Priority Tagged Frames without Priority Preservation (N:1 VLAN or 1:1 VLAN Architecture Single-Tagged at the V Interface)

Test Definition Number

ONU.6.1.16

Reference Document

BBF TR-156 [20]

BBF TR-101 [16]

ITU-T G.988 [6][7][8]

Test Type

Conformance

Test Requirement Type

Mandatory

Unit Under Test

ONU

Requirement Description**BBF TR-156:**

- **R-9** The ONU **MUST** support setting VID for untagged and priority-tagged frames in the upstream direction based on EtherType, except on VLANs used for Business Ethernet Services.

BBF TR-101:

- For each port configured as 'untagged or priority-tagged' or 'admit all', the Access Node **MUST** allow the operator to configure whether it should copy the priority marking of the received upstream priority-tagged frame to the S-tag (and C-tag, if applicable) or whether it should override it using an ingress to egress priority mapping

Test Objective

Verify that the ONU supports setting VID for priority-tagged frames in the upstream direction based on EtherType, for N:1 VLAN or 1:1 VLAN single-tagged at the V-interface, without priority preservation

Test Configuration

1. OLT Emulator and ONU under test are powered and connected to ODN

2. ONU under test has been activated by the OLT Emulator, has been ranged, and a GEM port for OMCI has been created as a result of ONU-ID assignment.
3. The Ethernet Traffic Generator is configured to transmit priority tagged Ethernet frames upstream with the following parameters

Upstream Direction																								
Traffic Stream	U Interface													R/S Interface										
	UNI	MAC DA	MAC SA	Outer VLAN Tag				Inner VLAN Tag				Ethertype	IP DA	IP SA	Outer VLAN Tag				Inner VLAN Tag				GEM	T-CONT
	Port #	Value	Value	TPID	Pbits	DEI	VID	TPID	Pbits	CFI or DEI	VID	Value	Value	Value	TPID	Pbits	DEI	VID	TPID	Pbits	CFI or DEI	VID	Port #	Number
A	1	MAC1	MAC2	n/a	n/a	n/a	n/a	0x8100	CPbits1	x	0	0x0800	x	x	n/a	n/a	n/a	n/a	0x88A8	SPbits1	x	SVID1	GEM1	TCONT1
B	1	MAC3	MAC4	n/a	n/a	n/a	n/a	0x8100	CPbits2	x	0	0x8863	x	x	n/a	n/a	n/a	n/a	0x88A8	SPbits1	x	SVID2	GEM1	TCONT1
C	1	MAC5	MAC6	n/a	n/a	n/a	n/a	0x8100	CPbits3	x	0	0x8864	n/a	n/a	n/a	n/a	n/a	n/a	0x88A8	SPbits1	x	SVID2	GEM1	TCONT1
D	1	MAC7	MAC8	n/a	n/a	n/a	n/a	0x8100	CPbits4	x	0	0x0806	n/a	n/a	n/a	n/a	n/a	n/a	0x88A8	SPbits1	x	SVID1	GEM1	TCONT1

4. For N:1 VLAN or 1:1 VLAN single-tagged at the V-interface, an S-Tag is added at the ONU for upstream traffic, as defined in the table above

Test Procedure

1. Select distinct random values for CPbits1, CPbits2, CPbits3, CPbits4, SVID1, SVID2 and SPbits1
2. Select distinct random values for the unicast MAC Addresses MAC1 and MAC2
3. Use the OLT Emulator to provision the ONU under test (via defined OMCI messages below) to support one N:1 VLAN or one 1:1 VLAN (single-tagged at the V-interface) subscriber with one user traffic class, requiring 1 GEM port (Alloc-ID, T-CONT, Port-ID).
4. Enable any frame monitoring/capture mechanisms on the OLT Emulator.
5. Cause the Ethernet Traffic Generator/Analyzer to transmit upstream Ethernet frames with the characteristics described in the test configuration section.

OMCI Procedure Details

Refer to clause 4.3.

Pass/Fail Criteria

The test passes if the following are true, otherwise the test fails:

1. Each OMCI response message must indicate success for the associated create or set command.
2. The uploaded ONU MIB must be consistent with the MIB held in the OLT Emulator
3. All upstream frames received by the OLT Emulator at the S/R-interface must be error free, with an S-Tag with a VID equal to SVID1 or SVID2 and S-Tag P-bits equal to SPbits1
4. SVID2 tagged frames must contain PPPoE Ethertypes.

Remarks

For more details see R-26/TR-101 [16] and R-27/TR-101 [16].

6.1.17 VID Support for Priority Tagged Frames with Priority Preservation (1:1 VLAN Architecture Double-Tagged at the V Interface)

Test Name

VID Support for Priority Tagged Frames with Priority Preservation (1:1 VLAN Architecture Double-Tagged at the V Interface)

Test Definition Number

ONU.6.1.17

Reference Document

BBF TR-156 [20]

BBF TR-101 [16]

ITU-T G.988 [6][7][8]

Test Type

Conformance

Test Requirement Type

Mandatory

Unit Under Test

ONU

Requirement Description**BBF TR-156:**

- **R-9** The ONU **MUST** support setting VID for untagged and priority-tagged frames in the upstream direction based on EtherType, except on VLANs used for Business Ethernet Services.

BBF TR-101:

- For each port configured as 'untagged or priority-tagged' or 'admit all', the Access Node **MUST** allow the operator to configure whether it should copy the priority marking of the received upstream priority-tagged frame to the S-tag (and C-tag, if applicable) or whether it should override it using an ingress to egress priority mapping

Test Objective

Verify that the ONU supports setting VID for priority-tagged frames in the upstream direction based on EtherType, for 1:1 VLAN double-tagged at the V-interface, with priority preservation

Test Configuration

1. OLT Emulator and ONU under test are powered and connected to ODN
2. ONU under test has been activated by the OLT Emulator, has been ranged, and a GEM port for OMCI has been created as a result of ONU-ID assignment.
3. The Ethernet Traffic Generator is configured to transmit priority tagged Ethernet frames upstream with the following parameters

Upstream Direction																								
Traffic Stream	U Interface												R/S Interface											
	UNI	MAC DA	MAC SA	Outer VLAN Tag				Inner VLAN Tag				Ethertype	IP DA	IP SA	Outer VLAN Tag				Inner VLAN Tag				GEM	T-CONT
	Port #	Value	Value	TPID	Pbits	DEI	VID	TPID	Pbits	CFI or DEI	VID	Value	Value	Value	TPID	Pbits	DEI	VID	TPID	Pbits	CFI or DEI	VID	Port #	Number
A	1	MAC1	MAC2	n/a	n/a	n/a	n/a	0x8100	CPbits1	x	0	0x0800	x	x	n/a	n/a	n/a	n/a	0x8100	CPbits1	x	CVID1	GEM1	TCONT1
B	1	MAC3	MAC4	n/a	n/a	n/a	n/a	0x8100	CPbits2	x	0	0x8863	x	x	n/a	n/a	n/a	n/a	0x8100	CPbits2	x	CVID2	GEM1	TCONT1
C	1	MAC5	MAC6	n/a	n/a	n/a	n/a	0x8100	CPbits2	x	0	0x8864	n/a	n/a	n/a	n/a	n/a	n/a	0x8100	CPbits2	x	CVID2	GEM1	TCONT1
D	1	MAC7	MAC8	n/a	n/a	n/a	n/a	0x8100	CPbits4	x	0	0x0806	n/a	n/a	n/a	n/a	n/a	n/a	0x8100	CPbits4	x	CVID1	GEM1	TCONT1

4. For 1:1 VLAN double-tagged at the V-interface, a C-Tag is added at the ONU for upstream traffic, as defined in the table above.

Test Procedure

1. Select distinct random values for CVID1, CVID2 and CPbits1, CPbits2, CPbits4
2. Select distinct random values for the unicast MAC Addresses MAC1 and MAC2
3. Use the OLT Emulator to provision the ONU under test (via defined OMCI messages below) to support one 1:1 VLAN (double-tagged at the V-interface) subscriber with one user traffic class, requiring 1 GEM port (Alloc-ID, T-CONT, Port-ID).
4. Enable any frame monitoring/capture mechanisms on the OLT Emulator.
5. Cause the Ethernet Traffic Generator/Analyzer to transmit upstream Ethernet frames with the characteristics described in the test configuration section.

OMCI Procedure Details

Refer to clause 4.3.

Pass/Fail Criteria

The test passes if the following are true, otherwise the test fails:

1. Each OMCI response message must indicate success for the associated create or set command.
2. The uploaded ONU MIB must be consistent with the MIB held in the OLT Emulator

3. All upstream frames received by the OLT Emulator at the S/R-interface must be error free, with a C-Tag with a VID equal to CVID1 or CVID2 and C-Tag P-bits equal to CPbits1, CPbits2, or CPbits4
4. CVID2 tagged frames must contain PPPoE Ethertypes.

Remarks

For more details see R-26/TR-101 [16] and R-27/TR-101 [16].

6.1.18 VID Support for Priority Tagged Frames without Priority Preservation (1:1 VLAN Architecture Double-Tagged at the V Interface)

Test Name

VID Support for Priority Tagged Frames without Priority Preservation (1:1 VLAN Architecture Double-Tagged at the V Interface)

Test Definition Number

ONU.6.1.18

Reference Document

BBF TR-156 [20]

BBF TR-101 [16]

ITU-T G.988 [6][7][8]

Test Type

Conformance

Test Requirement Type

Mandatory

Unit Under Test

ONU

Requirement Description**BBF TR-156:**

- **R-9** The ONU **MUST** support setting VID for untagged and priority-tagged frames in the upstream direction based on EtherType, except on VLANs used for Business Ethernet Services.

BBF TR-101:

- For each port configured as 'untagged or priority-tagged' or 'admit all', the Access Node **MUST** allow the operator to configure whether it should copy the priority marking of the received upstream priority-tagged frame to the S-tag (and C-tag, if applicable) or whether it should override it using an ingress to egress priority mapping

Test Objective

Verify that the ONU supports setting VID for priority-tagged frames in the upstream direction based on EtherType, for 1:1 VLAN double-tagged at the V-interface, without priority preservation

Test Configuration

1. OLT Emulator and ONU under test are powered and connected to ODN

- ONU under test has been activated by the OLT Emulator, has been ranged, and a GEM port for OMCI has been created as a result of ONU-ID assignment.
- The Ethernet Traffic Generator is configured to transmit priority tagged Ethernet frames upstream with the following parameters

Upstream Direction																								
Traffic Stream	U Interface												R/S Interface											
	UNI	MAC DA	MAC SA	Outer VLAN Tag				Inner VLAN Tag				Ethertype	IP DA	IP SA	Outer VLAN Tag				Inner VLAN Tag				GEM	T-CONT
	Port #	Value	Value	TPID	Pbits	DEI	VID	TPID	Pbits	CFI or DEI	VID	Value	Value	Value	TPID	Pbits	DEI	VID	TPID	Pbits	CFI or DEI	VID	Port #	Number
A	1	MAC1	MAC2	n/a	n/a	n/a	n/a	0x8100	CPbits1	x	0	0x0800	x	x	n/a	n/a	n/a	n/a	0x8100	CPbits2	x	CVID1	GEM1	TCONT1
B	1	MAC3	MAC4	n/a	n/a	n/a	n/a	0x8100	CPbits2	x	0	0x8863	x	x	n/a	n/a	n/a	n/a	0x8100	CPbits2	x	CVID2	GEM1	TCONT1
C	1	MAC5	MAC6	n/a	n/a	n/a	n/a	0x8100	CPbits3	x	0	0x8864	n/a	n/a	n/a	n/a	n/a	n/a	0x8100	CPbits2	x	CVID2	GEM1	TCONT1
D	1	MAC7	MAC8	n/a	n/a	n/a	n/a	0x8100	CPbits4	x	0	0x0806	n/a	n/a	n/a	n/a	n/a	n/a	0x8100	CPbits2	x	CVID1	GEM1	TCONT1

- For 1:1 VLAN double-tagged at the V-interface, a C-Tag is added at the ONU for upstream traffic, as defined in the table above

Test Procedure

- Select distinct random values for CVID1, CVID2 CPbits1, CPbits2, CPbits3, and CPbits4
- Select distinct random values for the unicast MAC Addresses MAC1 and MAC2
- Use the OLT Emulator to provision the ONU under test (via defined OMCI messages below) to support one 1:1 VLAN (double-tagged at the V-interface) subscriber with one user traffic class, requiring 1 GEM port (Alloc-ID, T-CONT, Port-ID).
- Enable any frame monitoring/capture mechanisms on the OLT Emulator.
- Cause the Ethernet Traffic Generator/Analyzer to transmit upstream Ethernet frames with the characteristics described in the test configuration section.

OMCI Procedure Details

Refer to clause 4.3.

Pass/Fail Criteria

The test passes if the following are true, otherwise the test fails:

- Each OMCI response message must indicate success for the associated create or set command.
- The uploaded ONU MIB must be consistent with the MIB held in the OLT Emulator
- All upstream frames received by the OLT Emulator at the S/R-interface must be error free, with a C-Tag with a VID equal to CVID1 or CVID2 and C-Tag P-bits equal to the CPbits2.
- CVID2 tagged frames must contain PPPoE Ethertypes.

Remarks

For more details see R-26/TR-101 [16] and R-27/TR-101 [16].

6.1.19 ONU addition and removal of C-Tag for 1:1 VLANs

Test Name

ONU addition and removal of C-Tag for 1:1 VLANs

Test Definition Number

ONU.6.1.19

Reference Document

BBF TR-156 [20]

ITU-T G.988 [6][7][8]

Test Type

Conformance

Test Requirement Type

Mandatory

Unit Under Test

ONU

Requirement Description

BBF TR-156:

- **R-20** The ONU MUST support adding a C-Tag or S-Tag to upstream untagged traffic.
- **R-21** The ONU MUST support removing the tag from downstream traffic.

Test Objective

To verify that the ONU implementation supports the addition and removal of a C-Tag to upstream and downstream frames respectively.

Test Configuration

1. OLT Emulator and ONU under test are connected to the ODN and powered on.
2. ONU activation and OMCC establishment processes have been successfully completed.
3. The OLT Emulator has instructed the ONU to reset its MIB to factory default values
4. The OLT Emulator will be configured to send the sequence of OMCI messages required to provision the ONU under test to support the following configuration:
5. Single untagged U-interface (removal of C-Tag from downstream packets and addition of C-Tag to upstream packets).
6. One unicast GEM port

7. The Traffic Generator and the OLT Emulator will be used to capture/report any upstream packets and generate any downstream packets.
8. The Ethernet traffic generator will be configured to capture/report any downstream packets and generate any upstream packets.

Upstream Direction																								
Traffic Stream	U Interface													R/S Interface										
	UNI	MAC DA	MAC SA	Outer VLAN Tag				Inner VLAN Tag				Ethertype	IP DA	IP SA	Outer VLAN Tag				Inner VLAN Tag				GEM	T-CONT
	Port #	Value	Value	TPID	Pbits	DEI	VID	TPID	Pbits	CFI or DEI	VID	Value	Value	Value	TPID	Pbits	DEI	VID	TPID	Pbits	CFI or DEI	VID	Port #	Number
A	1	MAC1	MAC2	n/a	n/a	n/a	n/a	n/a	n/a	n/a	n/a	x	x	x	n/a	n/a	n/a	n/a	0x8100	CPbits1	x	CVID1	GEM1	TCONT1
B	1	MAC1	MAC2	n/a	n/a	n/a	n/a	0x8100	CPbits1	x	CVID1	x	x	x	-	-	-	-	-	-	-	-	-	-
C	1	MAC1	MAC2	n/a	n/a	n/a	n/a	0x88A8	SPbits1	x	SVID1	x	x	x	-	-	-	-	-	-	-	-	-	-

Downstream Direction																							
Traffic Stream	S/R Interface														U Interface								
	MAC DA	MAC SA	Outer VLAN Tag				Inner VLAN Tag				Ethertype	IP DA	IP SA	GEM	Outer VLAN Tag				Inner VLAN Tag				UNI
	Value	Value	TPID	Pbits	DEI	VID	TPID	Pbits	CFI or DEI	VID	Value	Value	Value	Port #	TPID	Pbits	DEI	VID	TPID	Pbits	CFI or DEI	VID	Port #
D	MAC2	MAC1	n/a	n/a	n/a	n/a	0x8100	CPbits1	x	CVID1	x	x	x	GEM1	n/a	n/a	n/a	n/a	n/a	n/a	n/a	n/a	1

Test Procedure

1. Select random value for CVID1, SVID1, CPbits1, and SPbits1.
2. Select random unicast MAC addresses for MAC1 and MAC2.
3. Cause the OLT Emulator to send the configured OMCI message sequence to provision the ONU for 1:1 VLANs.
4. Enable any frame capture mechanism on the OLT Emulator and the Ethernet traffic generator.
5. Cause the OLT Emulator and Ethernet traffic generator to transmit the frames defined above.

OMCI Procedure Details

Refer to clause 4.3.

Pass/Fail Criteria

The test passes if the following are true, otherwise the test fails:

1. Upstream frames from Frame-Set A are received by the Ethernet Traffic Generator and the OLT Emulator as C-Tagged frames with VID = CVID1 and TPID = 0x8100.
2. Upstream frames from Frame-Sets B and C are silently discarded (not received by the OLT Emulator).
3. Downstream frames from Frame-Set D are received by the Ethernet traffic generator as untagged Ethernet frames.

Remarks

- None.

6.1.20 ONU addition and removal of S-Tag for 1:1 VLANs

Test Name

ONU addition and removal of S-Tag for 1:1 VLANs

Test Definition Number

ONU.6.1.20

Reference Document

BBF TR-156 [20]

ITU-T G.988 [6][7][8]

Test Type

Conformance

Test Requirement Type

Mandatory

Unit Under Test

ONU

Requirement Description

BBF TR-156:

- **R-20** The ONU MUST support adding a C-Tag or S-Tag to upstream untagged traffic.
- **R-21** The ONU MUST support removing the tag from downstream traffic.

Test Objective

To verify that the ONU implementation supports the addition and removal of an S-Tag to upstream and downstream frames respectively.

Test Configuration

1. OLT Emulator and ONU under test are connected to the ODN and powered on.
2. ONU activation and OMCC establishment processes have been successfully completed.
3. The OLT Emulator has instructed the ONU to reset its MIB to factory default values
4. The OLT Emulator will be configured to send the sequence of OMCI messages required to provision the ONU under test to support the following configuration:
5. Single untagged U-interface (removal of S-Tag from downstream packets and addition of S-Tag to upstream packets).

6. One unicast GEM port
7. The Ethernet Traffic Generator and the OLT Emulator will be used to capture/report any upstream packets and generate any downstream packets.
8. The Ethernet traffic generator will be configured to capture/report any downstream packets and generate any upstream packets.

Upstream Direction																								
Traffic Stream	U Interface														R/S Interface									
	UNI	MAC DA	MAC SA	Outer VLAN Tag				Inner VLAN Tag				Ethertype	IP DA	IP SA	Outer VLAN Tag				Inner VLAN Tag				GEM	T-CONT
	Port #	Value	Value	TPID	Pbits	DEI	VID	TPID	Pbits	CFI or DEI	VID	Value	Value	Value	TPID	Pbits	DEI	VID	TPID	Pbits	CFI or DEI	VID	Port #	Number
	A	1	MAC1	MAC2	n/a	n/a	n/a	n/a	n/a	n/a	n/a	n/a	x	x	x	n/a	n/a	n/a	n/a	0x88A8	SPbits1	x	SVID1	GEM1
B	1	MAC1	MAC2	n/a	n/a	n/a	n/a	0x8100	CPbits1	x	CVID1	x	x	x	-	-	-	-	-	-	-	-	-	-
C	1	MAC1	MAC2	n/a	n/a	n/a	n/a	0x88A8	SPbits1	x	SVID1	x	x	x	-	-	-	-	-	-	-	-	-	-

Downstream Direction																							
Traffic Stream	S/R Interface														U Interface								
	MAC DA	MAC SA	Outer VLAN Tag				Inner VLAN Tag				Ethertype	IP DA	IP SA	GEM	Outer VLAN Tag				Inner VLAN Tag				UNI
	Value	Value	TPID	Pbits	DEI	VID	TPID	Pbits	CFI or DEI	VID	Value	Value	Value	Port #	TPID	Pbits	DEI	VID	TPID	Pbits	CFI or DEI	VID	Port #
	D	MAC2	MAC1	n/a	n/a	n/a	n/a	0x88A8	SPbits1	x	SVID1	x	x	x	GEM1	n/a	n/a	n/a	n/a	n/a	n/a	n/a	n/a

Test Procedure

1. Select random value for CVID1, SVID1, CPbits1, and SPbits1 between 1 and 4094.
2. Select random unicast MAC addresses for MAC1 and MAC2.
3. Cause the OLT Emulator to send the configured OMCI message sequence to provision the ONU for 1:1 VLANs.
4. Enable any frame capture mechanism on the OLT Emulator and the Ethernet traffic generator.
5. Cause the OLT Emulator and Ethernet traffic generator to transmit the frames defined above.

OMCI Procedure Details

Refer to clause 4.3.

Pass/Fail Criteria

The test passes if the following are true, otherwise the test fails:

1. Upstream frames from Frame-Set A are received by the OLT Emulator as S-Tagged frames with VID = SVID1 and TPID = 0x88A8.
2. Upstream frames from Frame-Sets B and C are silently discarded (not received by the OLT Emulator).
3. Downstream frames from Frame-Set D are received by the Ethernet traffic generator as untagged Ethernet frames.

Remarks

- None.

6.1.21 ONU translation between Q-Tag and C-Tag for 1:1 VLANs

Test Name

ONU translation between Q-Tag and C-Tag for 1:1 VLANs

Test Definition Number

ONU.6.1.21

Reference Document

BBF TR-156 [20]

ITU-T G.988 [6][7][8]

Test Type

Conformance

Test Requirement Type

Mandatory

Unit Under Test

ONU

Requirement Description

BBF TR-156:

- **R-22** The ONU MUST support VID translation of the Q-Tag received from the U-interface into the C-Tag or S-Tag for upstream-tagged traffic.
- **R-23** The ONU MUST support VID translation of the tag used in the downstream-tagged traffic into the Q-Tag sent to the U-interface.

Test Objective

To verify that the ONU implementation supports the translation of Q-Tags into C-Tags and C-Tags into Q-Tags for upstream and downstream frames respectively.

Test Configuration

1. OLT Emulator and ONU under test are connected to the ODN and powered on.
2. ONU activation and OMCC establishment processes have been successfully completed.
3. The OLT Emulator has instructed the ONU to reset its MIB to factory default values
4. The OLT Emulator will be configured to send the sequence of OMCI messages required to provision the ONU under test to support the following configuration:

- Single tagged U-interface
 - Translation of Q-Tag into C-Tag in upstream direction and C-Tag into Q-Tag in the downstream direction
 - One unicast GEM port
5. The OLT Emulator will be used to capture/report any upstream packets and generate any downstream packets.
 6. The Ethernet traffic generator will be configured to capture/report any downstream packets and generate any upstream packets.

Upstream Direction																								
Traffic Stream	U Interface														R/S Interface									
	UNI	MAC DA	MAC SA	Outer VLAN Tag				Inner VLAN Tag				Ethertype	IP DA	IP SA	Outer VLAN Tag				Inner VLAN Tag				GEM	T-CONT
	Port #	Value	Value	TPID	Pbits	DEI	VID	TPID	Pbits	CFI or DEI	VID	Value	Value	Value	TPID	Pbits	DEI	VID	TPID	Pbits	CFI or DEI	VID	Port #	Number
A	1	MAC1	MAC2	n/a	n/a	n/a	n/a	0x8100	x	x	QVID1	x	x	x	n/a	n/a	n/a	n/a	0x8100	x	x	CVID2	GEM1	TCONT1
B	1	MAC1	MAC2	n/a	n/a	n/a	n/a	0x8100	x	x	QVID2	x	x	x	-	-	-	-	-	-	-	-	-	-
C	1	MAC1	MAC2	n/a	n/a	n/a	n/a	0x88A8	x	x	SVID2	x	x	x	-	-	-	-	-	-	-	-	-	-
D	1	MAC1	MAC2	n/a	n/a	n/a	n/a	n/a	n/a	n/a	n/a	x	x	x	-	-	-	-	-	-	-	-	-	-

Downstream Direction																							
Traffic Stream	S/R Interface														U Interface								
	MAC DA	MAC SA	Outer VLAN Tag				Inner VLAN Tag				Ethertype	IP DA	IP SA	GEM	Outer VLAN Tag				Inner VLAN Tag				UNI
	Value	Value	TPID	Pbits	DEI	VID	TPID	Pbits	CFI or DEI	VID	Value	Value	Value	Port #	TPID	Pbits	DEI	VID	TPID	Pbits	CFI or DEI	VID	Port #
E	MAC2	MAC1	n/a	n/a	n/a	n/a	0x8100	x	x	CVID2	x	x	x	GEM1	n/a	n/a	n/a	n/a	0x8100	x	x	QVID1	1

Test Procedure

1. Select random value for QVID1, QVID2, CVID2 and SVID2 between 1 and 4094.
2. Select random unicast MAC addresses for MAC1 and MAC2.
3. Cause the OLT Emulator to send the configured OMCI message sequence to provision the ONU for 1:1 VLANs.
4. Enable any frame capture mechanism on the OLT Emulator and the Ethernet traffic generator.
5. Cause the OLT Emulator and Ethernet traffic generator to transmit the frames defined above.

OMCI Procedure Details

Refer to clause 4.3.

Pass/Fail Criteria

The test passes if the following are true, otherwise the test fails:

1. Upstream frames from Frame-Set A are received by the OLT Emulator as C-Tagged frames with VID = CVID2 and TPID = 0x8100.
2. Upstream frames from Frame-Sets B through D are silently discarded (not received by the OLT Emulator).

3. Downstream frames from Frame-Set E are received by the Ethernet traffic generator as Q-Tagged Ethernet frames with VID = QVID1 and TPID = 0x8100.

Remarks

- None.

6.1.22 ONU translation between Q-Tag and S-Tag for 1:1 VLANs

Test Name

ONU translation between Q-Tag and S-Tag for 1:1 VLANs

Test Definition Number

ONU.6.1.22

Reference Document

BBF TR-156 [20]

ITU-T G.988 [6][7][8]

Test Type

Conformance

Test Requirement Type

Mandatory

Unit Under Test

ONU

Requirement Description

BBF TR-156:

- **R-22** The ONU MUST support VID translation of the Q-Tag received from the U-interface into the C-Tag or S-Tag for upstream-tagged traffic.
- **R-23** The ONU MUST support VID translation of the tag used in the downstream-tagged traffic into the Q-Tag sent to the U-interface.

Test Objective

To verify that the ONU implementation supports the translation of Q-Tags into S-Tags and S-Tags into Q-Tags for upstream and downstream frames respectively.

Test Configuration

1. OLT Emulator and ONU under test are connected to the ODN and powered on.
2. ONU activation and OMCC establishment processes have been successfully completed.
3. The OLT Emulator has instructed the ONU to reset its MIB to factory default values
4. The OLT Emulator will be configured to send the sequence of OMCI messages required to provision the ONU under test to support the following configuration:

- Single tagged U-interface
 - Translation of Q-Tag into S-Tag in upstream direction and S-Tag into Q-Tag in the downstream direction
 - One unicast GEM port
5. The OLT Emulator will be used to capture/report any upstream packets and generate any downstream packets.
 6. The Ethernet traffic generator will be configured to capture/report any downstream packets and generate any upstream packets.

Upstream Direction																								
Traffic Stream	U Interface														R/S Interface									
	UNI	MAC DA	MAC SA	Outer VLAN Tag				Inner VLAN Tag				Ethertype	IP DA	IP SA	Outer VLAN Tag				Inner VLAN Tag				GEM	T-CONT
	Port #	Value	Value	TPID	Pbits	DEI	VID	TPID	Pbits	CFI or DEI	VID	Value	Value	Value	TPID	Pbits	DEI	VID	TPID	Pbits	CFI or DEI	VID	Port #	Number
A	1	MAC1	MAC2	n/a	n/a	n/a	n/a	0x8100	x	x	QVID1	x	x	x	n/a	n/a	n/a	n/a	0x88A8	x	x	SVID2	GEM1	TCONT1
B	1	MAC1	MAC2	n/a	n/a	n/a	n/a	0x8100	x	x	QVID2	x	x	x	-	-	-	-	-	-	-	-	-	-
C	1	MAC1	MAC2	n/a	n/a	n/a	n/a	0x88A8	x	x	SVID2	x	x	x	-	-	-	-	-	-	-	-	-	-
D	1	MAC1	MAC2	n/a	n/a	n/a	n/a	n/a	n/a	n/a	n/a	x	x	x	-	-	-	-	-	-	-	-	-	-

Downstream Direction																							
Traffic Stream	S/R Interface														U Interface								
	MAC DA	MAC SA	Outer VLAN Tag				Inner VLAN Tag				Ethertype	IP DA	IP SA	GEM	Outer VLAN Tag				Inner VLAN Tag				UNI
	Value	Value	TPID	Pbits	DEI	VID	TPID	Pbits	CFI or DEI	VID	Value	Value	Value	Port #	TPID	Pbits	DEI	VID	TPID	Pbits	CFI or DEI	VID	Port #
E	MAC2	MAC1	n/a	n/a	n/a	n/a	0x88A8	x	x	SVID2	x	x	x	GEM1	n/a	n/a	n/a	n/a	0x8100	x	x	QVID1	1

Test Procedure

1. Select random value for QVID1, QVID2, and SVID2.
2. Select random unicast MAC addresses for MAC1 and MAC2.
3. Cause the OLT Emulator to send the configured OMCI message sequence to provision the ONU for 1:1 VLANs based on the tables above.
4. Enable any frame capture mechanism on the OLT Emulator and the Ethernet traffic generator.
5. Cause the OLT Emulator and Ethernet traffic generator to transmit the frames defined above.

OMCI Procedure Details

Refer to clause 4.3.

Pass/Fail Criteria

The test passes if the following are true, otherwise the test fails:

1. Upstream frames from Frame-Set A are received by the OLT Emulator as S-Tagged frames with VID = SVID2, and TPID = 0x88A8.
2. Upstream frames from Frame-Sets B through D are silently discarded (not received by the OLT Emulator).

3. Downstream frames from Frame-Set E are received by the Ethernet traffic generator as Q-Tagged Ethernet frames with VID = QVID1 and TPID = 0x8100.

Remarks

- None.

6.1.23 Test case reserved for future use.

6.1.24 Deriving P-bits as a function of received P-bits for a VBES architecture (single user port)

Test Name

Deriving P-bits as a function of received P-bits for a VBES architecture (single user port)

Test Definition Number

ONU.6.1.24

Reference Document

BBF TR-156 [20]

ITU-T G.988 [6][7][8]

Test Type

Conformance

Test Requirement Type

Mandatory

Unit Under Test

ONU

Requirement Description**BBF TR-156:**

- **R-48** The ONU MUST support deriving P-bit markings in the upstream direction based on an arbitrary combination of: user port, VID, received P-bit markings, and EtherType.
Note: Only derivation from received P-bit markings is verified by this test case.
- **Also, R-6, 7, 46, 50.**

Test Objective

Show that ONU can derive P-bit marking as a function of received P-bits.

Test Configuration

For this test, only a single user port is assumed.

ONU must be set-up with the standard L2-OCM (single user) with one upstream queues and one associated T-CONT. The intent of the test is to define two flows based on different P-bit values at the U-interface. Each flow at R/S will have an S-tag with a different P-bit value.

The U-interface and S/R-interface values for each test are shown below, along with the GEM port and T-CONT configuration.

Upstream Direction																								
Traffic Stream	U Interface													R/S Interface										
	UNI	MAC DA	MAC SA	Outer VLAN Tag				Inner VLAN Tag				Ethertype	IP DA	IP SA	Outer VLAN Tag				Inner VLAN Tag				GEM	T-CONT
	Port #	Value	Value	TPID	Pbits	DEI	VID	TPID	Pbits	CFI or DEI	VID	Value	Value	Value	TPID	Pbits	DEI	VID	TPID	Pbits	CFI or DEI	VID	Port #	Number
A	1	MAC1	MAC2	n/a	n/a	n/a	n/a	0x88A8	SPbits3	x	SVID2	x	x	x	n/a	n/a	n/a	n/a	0x88A8	SPbits1	x	SVID1	GEM1	TCONT1
B	1	MAC3	MAC4	n/a	n/a	n/a	n/a	0x88A8	SPbits4	x	SVID2	x	x	x	n/a	n/a	n/a	n/a	0x88A8	SPbits2	x	SVID1	GEM2	TCONT1

Traffic corresponding to each flow will produce a different P-bit marking.

Test Procedure

For each test number in the above table, inject at the U-interface tagged traffic with the specified P-bit values. Verify that specified P-bit values are observed at the S/R-interface.

OMCI Procedure Details

Refer to clause 4.3.

Pass/Fail Criteria

The test passes if the following are true, otherwise the test fails:

1. All OMCI commands have Success responses
2. A MIB upload and compare matches the MIB expected by the OLT
3. The resulting P-bit values in each of the tests above is as specified.

Remarks

- None.

6.1.25 Deriving P-bits as a function of received VID for a 1:1 or N:1 architecture (single user port)

Test Name

Deriving P-bits as a function of received VID for a 1:1 or N:1 architecture (single user port)

Test Definition Number

ONU.6.1.25

Reference Document

BBF TR-156 [20]

ITU-T G.988 [6][7][8]

Test Type

Conformance

Test Requirement Type

Mandatory

Unit Under Test

ONU

Requirement Description**BBF TR-156:**

- **R-48** The ONU MUST support deriving P-bit markings in the upstream direction based on an arbitrary combination of: user port, VID, received P-bit markings, and EtherType.
- **Also, R-6, 7, 50.**

Test Objective

Show that ONU can derive P-bit marking as a function of received VID.

Test Configuration

For this test, only a single user port is assumed.

ONU must be set-up with the standard L2 OCM (single user) with three upstream queues and two associated T-CONTs. The intent of the test is to define two flows based on 2 different VID values at the U-interface. Each flow at R/S will have an S-tag with a specified P-bit value.

The U-interface and S/R-interface values for each test are shown below, along with the GEM port and T-CONT configuration.

Upstream Direction																								
Traffic Stream	U Interface													R/S Interface										
	UNI	MAC DA	MAC SA	Outer VLAN Tag				Inner VLAN Tag				Ethertype	IP DA	IP SA	Outer VLAN Tag				Inner VLAN Tag				GEM	T-CONT
	Port #	Value	Value	TPID	Pbits	DEI	VID	TPID	Pbits	CFI or DEI	VID	Value	Value	Value	TPID	Pbits	DEI	VID	TPID	Pbits	CFI or DEI	VID	Port #	Number
A	1	MAC1	MAC2	n/a	n/a	n/a	n/a	0x8100	x	x	CVID1	x	x	x	n/a	n/a	n/a	n/a	0x88A8	SPbits1	X	SVID1	GEM1	TCONT1
B	1	MAC1	MAC2	n/a	n/a	n/a	n/a	0x8100	x	x	CVID2	x	x	x	n/a	n/a	n/a	n/a	0x88A8	SPbits2	X	SVID1	GEM2	TCONT2

Traffic corresponding to each flow will produce a different P-bit marking.

Test Procedure

For each test number in the above table, inject at the U-interface tagged traffic with the specified VID values. Verify that specified P-bit values are observed at the S/R-interface.

OMCI Procedure Details

Refer to clause 4.3.

Pass/Fail Criteria

The test passes if the following are true, otherwise the test fails:

1. All OMCI commands have Success responses
2. A MIB upload and compare matches the MIB expected by the OLT
3. The resulting P-bit values in each of the tests above is as specified.

Remarks

- None.

6.1.26 Deriving P-bits as a function of received Ethertype for a 1:1 or N:1 architecture (single user port)

Test Name

Deriving P-bits as a function of received Ethertype for a 1:1 or N:1 architecture (single user port)

Test Definition Number

ONU.6.1.26

Reference Document

BBF TR-156 [20]

ITU-T G.988 [6][7][8]

Test Type

Conformance

Test Requirement Type

Mandatory

Unit Under Test

ONU

Requirement Description**BBF TR-156:**

- **R-48** The ONU MUST support deriving P-bit markings in the upstream direction based on an arbitrary combination of: user port, VID, received P-bit markings, and EtherType.
- **Also, R-6, 7, 50.**

Test Objective

Show that ONU can derive P-bit marking as a function of received Ethertype.

Test Configuration

For this test, only a single user port is assumed.

ONU must be set-up with the standard L2 OCM (single user) with two upstream queues and two associated T-CONTs. The intent of the test is to define two flows based on different Ethertype values at the U-interface. (Ethertype=0x8863 is PPPoE; Ethertype=0x0800 is IPoE) Each flow at R/S will have an S-tag with P-bit value different from the other flow.

The U-interface and S/R-interface values for each test are shown below, along with the GEM port and T-CONT configuration.

Upstream Direction																								
Traffic Stream	U Interface													R/S Interface										
	UNI	MAC DA	MAC SA	Outer VLAN Tag				Inner VLAN Tag				Ethertype	IP DA	IP SA	Outer VLAN Tag				Inner VLAN Tag				GEM	T-CONT
	Port #	Value	Value	TPID	Pbits	DEI	VID	TPID	Pbits	CFI or DEI	VID	Value	Value	Value	TPID	Pbits	DEI	VID	TPID	Pbits	CFI or DEI	VID	Port #	Number
A	1	MAC1	MAC2	n/a	n/a	n/a	n/a	0x8100	CPbits1	x	CVID1	0x8863	x	x	n/a	n/a	n/a	n/a	0x88A8	SPbits1	x	SVID1	GEM1	TCONT1
B	1	MAC1	MAC2	n/a	n/a	n/a	n/a	0x8100	CPbits1	x	CVID1	0x0800	x	x	n/a	n/a	n/a	n/a	0x88A8	SPbits2	x	SVID1	GEM2	TCONT2

Traffic corresponding to each flow will produce a different P-bit marking.

Test Procedure

For each test number in the above table, inject at the U-interface tagged traffic with the specified Ethertype values. Verify that specified P-bit values are observed at the S/R-interface.

OMCI Procedure Details

Refer to clause 4.3.

Pass/Fail Criteria

The test passes if the following are true, otherwise the test fails:

1. All OMCI commands have Success responses
2. A MIB upload and compare matches the MIB expected by the OLT
3. The resulting P-bit values in each of the tests above is as specified.

Remarks

- None.

6.1.27 Deriving P-bits as a function of received user port for a 1:1 or N:1 architecture

Test Name

Deriving P-bits as a function of received user port for a 1:1 or N:1 architecture

Test Definition Number

ONU.6.1.27

Reference Document

BBF TR-156 [20]

ITU-T G.988 [6][7][8]

Test Type

Conformance

Test Requirement Type

Conditionally Mandatory (if ONT has multiple user ports)

Unit Under Test

ONU

Requirement Description**TR-156:**

- **R-48** The ONU MUST support deriving P-bit markings in the upstream direction based on an arbitrary combination of: user port, VID, received P-bit markings, and EtherType.
- **Also, R-6, 7, 50.**

Test Objective

Show that ONU can derive P-bit marking as a function of received user port.

Test Configuration

For this test, multiple user ports are assumed. Therefore, multiple bridges must be provisioned in the OMCI model.

ONU must be set-up with the standard L2 OCM (multiple user port) with two upstream queues and two associated T-CONTs. The intent of the test is to define two streams per user ports. Each stream at R/S will have an S-tag with P-bit value based on user port.

The U-interface and S/R interface values for each test are shown below, along with the GEM port and T-CONT configuration.

Upstream Direction																								
Traffic Stream	U Interface													R/S Interface										
	UNI	MAC DA	MAC SA	Outer VLAN Tag				Inner VLAN Tag				Ethertype	IP DA	IP SA	Outer VLAN Tag				Inner VLAN Tag				GEM	T-CONT
	Port #	Value	Value	TPID	Pbits	DEI	VID	TPID	Pbits	CFI or DEI	VID	Value	Value	Value	TPID	Pbits	DEI	VID	TPID	Pbits	CFI or DEI	VID	Port #	Number
A	1	MAC1	MAC2	n/a	n/a	n/a	n/a	0x8100	CPbits1	x	CVID1	x	x	x	n/a	n/a	n/a	n/a	0x88A8	SPbits1	0	SVID1	GEM1	TCONT1
B	2	MAC3	MAC4	n/a	n/a	n/a	n/a	0x8100	CPbits1	x	CVID1	x	x	x	n/a	n/a	n/a	n/a	0x88A8	SPbits2	0	SVID1	GEM2	TCONT2
C	1	MAC1	MAC2	n/a	n/a	n/a	n/a	n/a	n/a	n/a	n/a	x	x	x	n/a	n/a	n/a	n/a	0x88A8	SPbits1	x	SVID1	GEM1	TCONT1
D	2	MAC3	MAC4	n/a	n/a	n/a	n/a	n/a	n/a	n/a	n/a	x	x	x	n/a	n/a	n/a	n/a	0x88A8	SPbits2	x	SVID1	GEM2	TCONT2

Traffic corresponding to each flow will produce a different P-bit marking.

Test Procedure

1. select distinct random values for CVID1, SVID1, CPbit1, SPbit1, SPbit2
2. Configure L2 OCM for the test sequence number 1
3. Inject flow A to D at the U-Interface
4. Use the G-PON analyser or OLT Emulator, to verify that P-bits are correctly assigned as a function of received user port

OMCI Procedure Details

Refer to clause 4.3.

Pass/Fail Criteria

The test passes if all of following are true:

1. All OMCI commands have Success responses
2. A MIB upload and compare matches the MIB expected by the OLT
3. The resulting P-bit values in each of the tests above is as specified (at step 4).

Otherwise the test fails.

Remarks

- None.

6.1.28 Support of 67 Entries on extended VLAN tagging operation table and 8 VLANs

Test Name

Support of 67 Entries on extended VLAN tagging operation table and 8 VLANs

Test Definition Number

ONU.6.1.28

Reference Document

BBF TR-280 [23]

ITU-T G.988 [6][7][8]

Test Type

Conformance

Test Requirement Type

Mandatory

Unit Under Test

ONU

Requirement Description

BBF TR-280

- **R-63** The ONU MUST support at least 8 simultaneously active VLAN per U interface
- **R-64** The ONU MUST support at least 67 entries in the Extended VLAN tagging operation table including the auto created default entries.

Test Objective

Verify that the ONU is able to support at least 67 entries in the Extended VLAN tagging operation table including the auto created default entries.

Test Configuration

1. OLT Emulator and ONU under test are powered and connected to ODN
2. ONU activation and OMCC establishment processes have been successfully completed.
3. The OLT Emulator will be configured to send the sequence of OMCI messages required to provision the ONU under test
 - to support 4 traffic classes, each one associated to a different P-bit value (i.e., P-bit mapping)

- with 4 GEM ports and 4 downstream queues, each pair of GEM port-downstream queue assigned to one traffic classes

- The Ethernet Traffic Generator and the OLT Emulator will be configured to transmit flows of double-tagged Ethernet frames with the parameters in the next table. Also, GEM port mapping is shown.

Upstream Direction																								
Traffic Stream	U Interface													R/S Interface										
	UNI	MAC DA	MAC SA	Outer VLAN Tag				Inner VLAN Tag				Ethertype	IP DA	IP SA	Outer VLAN Tag				Inner VLAN Tag				GEM	T-CONT
	Port #	Value	Value	TPID	Pbits	DEI	VID	TPID	Pbits	CFI or DEI	VID	Value	Value	Value	TPID	Pbits	DEI	VID	TPID	Pbits	CFI or DEI	VID	Port #	Number
A	1	MAC1	MAC2	n/a	n/a	n/a	n/a	0x8100	0	n/a	CVID1	0x0800	x	x	n/a	n/a	n/a	n/a	0x88A8	0	x	SVID1	GEM1	TCONT1
B	1	MAC1	MAC2	n/a	n/a	n/a	n/a	0x8100	1	n/a	CVID1	0x0800	x	x	n/a	n/a	n/a	n/a	0x88A8	1	x	SVID1	GEM2	TCONT2
C	1	MAC1	MAC2	n/a	n/a	n/a	n/a	0x8100	2	n/a	CVID1	0x0800	x	x	n/a	n/a	n/a	n/a	0x88A8	2	x	SVID1	GEM3	TCONT3
D	1	MAC1	MAC2	n/a	n/a	n/a	n/a	0x8100	3	n/a	CVID1	0x0800	x	x	n/a	n/a	n/a	n/a	0x88A8	3	x	SVID1	GEM4	TCONT4
E	1	MAC1	MAC2	n/a	n/a	n/a	n/a	0x8100	4	n/a	CVID1	0x0800	x	x	n/a	n/a	n/a	n/a	0x88A8	4	x	SVID1	GEM1	TCONT1
F	1	MAC1	MAC2	n/a	n/a	n/a	n/a	0x8100	5	n/a	CVID1	0x0800	x	x	n/a	n/a	n/a	n/a	0x88A8	5	x	SVID1	GEM2	TCONT2
G	1	MAC1	MAC2	n/a	n/a	n/a	n/a	0x8100	6	n/a	CVID1	0x0800	x	x	n/a	n/a	n/a	n/a	0x88A8	6	x	SVID1	GEM3	TCONT3
H	1	MAC1	MAC2	n/a	n/a	n/a	n/a	0x8100	7	n/a	CVID1	0x0800	x	x	n/a	n/a	n/a	n/a	0x88A8	7	x	SVID1	GEM4	TCONT4
I	1	MAC1	MAC2	n/a	n/a	n/a	n/a	0x8100	1	n/a	CVID2	0x0800	x	x	n/a	n/a	n/a	n/a	0x88A8	0	x	SVID2	GEM1	TCONT1
J	1	MAC1	MAC2	n/a	n/a	n/a	n/a	0x8100	2	n/a	CVID2	0x0800	x	x	n/a	n/a	n/a	n/a	0x88A8	1	x	SVID2	GEM2	TCONT2
H	1	MAC1	MAC2	n/a	n/a	n/a	n/a	0x8100	3	n/a	CVID2	0x0800	x	x	n/a	n/a	n/a	n/a	0x88A8	2	x	SVID2	GEM3	TCONT3
I	1	MAC1	MAC2	n/a	n/a	n/a	n/a	0x8100	4	n/a	CVID2	0x0800	x	x	n/a	n/a	n/a	n/a	0x88A8	3	x	SVID2	GEM4	TCONT4
J	1	MAC1	MAC2	n/a	n/a	n/a	n/a	0x8100	5	n/a	CVID2	0x0800	x	x	n/a	n/a	n/a	n/a	0x88A8	4	x	SVID2	GEM1	TCONT1
K	1	MAC1	MAC2	n/a	n/a	n/a	n/a	0x8100	6	n/a	CVID2	0x0800	x	x	n/a	n/a	n/a	n/a	0x88A8	5	x	SVID2	GEM2	TCONT2
L	1	MAC1	MAC2	n/a	n/a	n/a	n/a	0x8100	7	n/a	CVID2	0x0800	x	x	n/a	n/a	n/a	n/a	0x88A8	6	x	SVID2	GEM3	TCONT3
M	1	MAC1	MAC2	n/a	n/a	n/a	n/a	0x8100	0	n/a	CVID2	0x0800	x	x	n/a	n/a	n/a	n/a	0x88A8	7	x	SVID2	GEM4	TCONT4
N	1	MAC1	MAC2	n/a	n/a	n/a	n/a	0x8100	2	n/a	CVID3	0x0800	x	x	n/a	n/a	n/a	n/a	0x88A8	0	x	SVID3	GEM1	TCONT1
O	1	MAC1	MAC2	n/a	n/a	n/a	n/a	0x8100	3	n/a	CVID3	0x0800	x	x	n/a	n/a	n/a	n/a	0x88A8	1	x	SVID3	GEM2	TCONT2
P	1	MAC1	MAC2	n/a	n/a	n/a	n/a	0x8100	4	n/a	CVID3	0x0800	x	x	n/a	n/a	n/a	n/a	0x88A8	2	x	SVID3	GEM3	TCONT3
Q	1	MAC1	MAC2	n/a	n/a	n/a	n/a	0x8100	5	n/a	CVID3	0x0800	x	x	n/a	n/a	n/a	n/a	0x88A8	3	x	SVID3	GEM4	TCONT4
R	1	MAC1	MAC2	n/a	n/a	n/a	n/a	0x8100	6	n/a	CVID3	0x0800	x	x	n/a	n/a	n/a	n/a	0x88A8	4	x	SVID3	GEM1	TCONT1
S	1	MAC1	MAC2	n/a	n/a	n/a	n/a	0x8100	7	n/a	CVID3	0x0800	x	x	n/a	n/a	n/a	n/a	0x88A8	5	x	SVID3	GEM2	TCONT2
T	1	MAC1	MAC2	n/a	n/a	n/a	n/a	0x8100	0	n/a	CVID3	0x0800	x	x	n/a	n/a	n/a	n/a	0x88A8	6	x	SVID3	GEM3	TCONT3
U	1	MAC1	MAC2	n/a	n/a	n/a	n/a	0x8100	1	n/a	CVID3	0x0800	x	x	n/a	n/a	n/a	n/a	0x88A8	7	x	SVID3	GEM4	TCONT4
V	1	MAC1	MAC2	n/a	n/a	n/a	n/a	0x8100	3	n/a	CVID4	0x0800	x	x	n/a	n/a	n/a	n/a	0x88A8	0	x	SVID4	GEM1	TCONT1
W	1	MAC1	MAC2	n/a	n/a	n/a	n/a	0x8100	4	n/a	CVID4	0x0800	x	x	n/a	n/a	n/a	n/a	0x88A8	1	x	SVID4	GEM2	TCONT2
X	1	MAC1	MAC2	n/a	n/a	n/a	n/a	0x8100	5	n/a	CVID4	0x0800	x	x	n/a	n/a	n/a	n/a	0x88A8	2	x	SVID4	GEM3	TCONT3
Y	1	MAC1	MAC2	n/a	n/a	n/a	n/a	0x8100	6	n/a	CVID4	0x0800	x	x	n/a	n/a	n/a	n/a	0x88A8	3	x	SVID4	GEM4	TCONT4
Z	1	MAC1	MAC2	n/a	n/a	n/a	n/a	0x8100	7	n/a	CVID4	0x0800	x	x	n/a	n/a	n/a	n/a	0x88A8	4	x	SVID4	GEM1	TCONT1
AA	1	MAC1	MAC2	n/a	n/a	n/a	n/a	0x8100	0	n/a	CVID4	0x0800	x	x	n/a	n/a	n/a	n/a	0x88A8	5	x	SVID4	GEM2	TCONT2

AB	1	MAC1	MAC2	n/a	n/a	n/a	n/a	0x8100	1	n/a	CVID4	0x0800	x	x	n/a	n/a	n/a	n/a	0x88A8	6	x	SVID4	GEM3	TCONT3
AC	1	MAC1	MAC2	n/a	n/a	n/a	n/a	0x8100	2	n/a	CVID4	0x0800	x	x	n/a	n/a	n/a	n/a	0x88A8	7	x	SVID4	GEM4	TCONT4
AD	1	MAC1	MAC2	n/a	n/a	n/a	n/a	0x8100	4	n/a	CVID5	0x0800	x	x	n/a	n/a	n/a	n/a	0x88A8	0	x	SVID5	GEM1	TCONT1
AE	1	MAC1	MAC2	n/a	n/a	n/a	n/a	0x8100	5	n/a	CVID5	0x0800	x	x	n/a	n/a	n/a	n/a	0x88A8	1	x	SVID5	GEM2	TCONT2
AF	1	MAC1	MAC2	n/a	n/a	n/a	n/a	0x8100	6	n/a	CVID5	0x0800	x	x	n/a	n/a	n/a	n/a	0x88A8	2	x	SVID5	GEM3	TCONT3
AF	1	MAC1	MAC2	n/a	n/a	n/a	n/a	0x8100	7	n/a	CVID5	0x0800	x	x	n/a	n/a	n/a	n/a	0x88A8	3	x	SVID5	GEM4	TCONT4
AG	1	MAC1	MAC2	n/a	n/a	n/a	n/a	0x8100	0	n/a	CVID5	0x0800	x	x	n/a	n/a	n/a	n/a	0x88A8	4	x	SVID5	GEM1	TCONT1
AH	1	MAC1	MAC2	n/a	n/a	n/a	n/a	0x8100	1	n/a	CVID5	0x0800	x	x	n/a	n/a	n/a	n/a	0x88A8	5	x	SVID5	GEM2	TCONT2
AI	1	MAC1	MAC2	n/a	n/a	n/a	n/a	0x8100	2	n/a	CVID5	0x0800	x	x	n/a	n/a	n/a	n/a	0x88A8	6	x	SVID5	GEM3	TCONT3
AJ	1	MAC1	MAC2	n/a	n/a	n/a	n/a	0x8100	3	n/a	CVID5	0x0800	x	x	n/a	n/a	n/a	n/a	0x88A8	7	x	SVID5	GEM4	TCONT4
AK	1	MAC1	MAC2	n/a	n/a	n/a	n/a	0x8100	5	n/a	CVID6	0x0800	x	x	n/a	n/a	n/a	n/a	0x88A8	0	x	SVID6	GEM1	TCONT1
AL	1	MAC1	MAC2	n/a	n/a	n/a	n/a	0x8100	6	n/a	CVID6	0x0800	x	x	n/a	n/a	n/a	n/a	0x88A8	1	x	SVID6	GEM2	TCONT2
AM	1	MAC1	MAC2	n/a	n/a	n/a	n/a	0x8100	7	n/a	CVID6	0x0800	x	x	n/a	n/a	n/a	n/a	0x88A8	2	x	SVID6	GEM3	TCONT3
AN	1	MAC1	MAC2	n/a	n/a	n/a	n/a	0x8100	0	n/a	CVID6	0x0800	x	x	n/a	n/a	n/a	n/a	0x88A8	3	x	SVID6	GEM4	TCONT4
AP	1	MAC1	MAC2	n/a	n/a	n/a	n/a	0x8100	1	n/a	CVID6	0x0800	x	x	n/a	n/a	n/a	n/a	0x88A8	4	x	SVID6	GEM1	TCONT1
AQ	1	MAC1	MAC2	n/a	n/a	n/a	n/a	0x8100	2	n/a	CVID6	0x0800	x	x	n/a	n/a	n/a	n/a	0x88A8	5	x	SVID6	GEM2	TCONT2
AR	1	MAC1	MAC2	n/a	n/a	n/a	n/a	0x8100	3	n/a	CVID6	0x0800	x	x	n/a	n/a	n/a	n/a	0x88A8	6	x	SVID6	GEM3	TCONT3
AS	1	MAC1	MAC2	n/a	n/a	n/a	n/a	0x8100	4	n/a	CVID6	0x0800	x	x	n/a	n/a	n/a	n/a	0x88A8	7	x	SVID6	GEM4	TCONT4
AT	1	MAC1	MAC2	n/a	n/a	n/a	n/a	0x8100	6	n/a	CVID7	0x0800	x	x	n/a	n/a	n/a	n/a	0x88A8	0	x	SVID7	GEM1	TCONT1
AU	1	MAC1	MAC2	n/a	n/a	n/a	n/a	0x8100	7	n/a	CVID7	0x0800	x	x	n/a	n/a	n/a	n/a	0x88A8	1	x	SVID7	GEM2	TCONT2
AV	1	MAC1	MAC2	n/a	n/a	n/a	n/a	0x8100	0	n/a	CVID7	0x0800	x	x	n/a	n/a	n/a	n/a	0x88A8	2	x	SVID7	GEM3	TCONT3
AW	1	MAC1	MAC2	n/a	n/a	n/a	n/a	0x8100	1	n/a	CVID7	0x0800	x	x	n/a	n/a	n/a	n/a	0x88A8	3	x	SVID7	GEM4	TCONT4
AX	1	MAC1	MAC2	n/a	n/a	n/a	n/a	0x8100	2	n/a	CVID7	0x0800	x	x	n/a	n/a	n/a	n/a	0x88A8	4	x	SVID7	GEM1	TCONT1
AY	1	MAC1	MAC2	n/a	n/a	n/a	n/a	0x8100	3	n/a	CVID7	0x0800	x	x	n/a	n/a	n/a	n/a	0x88A8	5	x	SVID7	GEM2	TCONT2
AZ	1	MAC1	MAC2	n/a	n/a	n/a	n/a	0x8100	4	n/a	CVID7	0x0800	x	x	n/a	n/a	n/a	n/a	0x88A8	6	x	SVID7	GEM3	TCONT3
BA	1	MAC1	MAC2	n/a	n/a	n/a	n/a	0x8100	5	n/a	CVID7	0x0800	x	x	n/a	n/a	n/a	n/a	0x88A8	7	x	SVID7	GEM4	TCONT4
BB	1	MAC1	MAC2	n/a	n/a	n/a	n/a	0x8100	7	n/a	CVID8	0x0800	x	x	n/a	n/a	n/a	n/a	0x88A8	0	x	SVID8	GEM1	TCONT1
BC	1	MAC1	MAC2	n/a	n/a	n/a	n/a	0x8100	0	n/a	CVID8	0x0800	x	x	n/a	n/a	n/a	n/a	0x88A8	1	x	SVID8	GEM2	TCONT2
BD	1	MAC1	MAC2	n/a	n/a	n/a	n/a	0x8100	1	n/a	CVID8	0x0800	x	x	n/a	n/a	n/a	n/a	0x88A8	2	x	SVID8	GEM3	TCONT3
BE	1	MAC1	MAC2	n/a	n/a	n/a	n/a	0x8100	2	n/a	CVID8	0x0800	x	x	n/a	n/a	n/a	n/a	0x88A8	3	x	SVID8	GEM4	TCONT4
BF	1	MAC1	MAC2	n/a	n/a	n/a	n/a	0x8100	3	n/a	CVID8	0x0800	x	x	n/a	n/a	n/a	n/a	0x88A8	4	x	SVID8	GEM1	TCONT1
BH	1	MAC1	MAC2	n/a	n/a	n/a	n/a	0x8100	4	n/a	CVID8	0x0800	x	x	n/a	n/a	n/a	n/a	0x88A8	5	x	SVID8	GEM2	TCONT2
BI	1	MAC1	MAC2	n/a	n/a	n/a	n/a	0x8100	5	n/a	CVID8	0x0800	x	x	n/a	n/a	n/a	n/a	0x88A8	6	x	SVID8	GEM3	TCONT3
BJ	1	MAC1	MAC2	n/a	n/a	n/a	n/a	0x8100	6	n/a	CVID8	0x0800	x	x	n/a	n/a	n/a	n/a	0x88A8	7	x	SVID8	GEM4	TCONT4

Downstream Direct bn																									
Traf # Stream	S/R Interface														U Interface										
	MAC DA		MAC SA		Outer VLAN Tag				Inner VLAN Tag				Ethertype	IP DA	IP SA	GEM	Outer VLAN Tag				Inner VLAN Tag				UNI
	Value	Value	TPID	Pbits	DEI	VID	TPID	Pbits	CFI or DEI	VID	Value	Value	Value	Port #	TPID	Pbits	DEI	VID	TPID	Pbits	CFI or DEI	VID	Port #		
A	MAC2	MAC1	n/a	n/a	n/a	n/a	0x88A8	0	x	SVID1	0x0800	x	x	GEM1	n/a	n/a	n/a	n/a	0x8100	0	n/a	CVID1	1		
B	MAC2	MAC1	n/a	n/a	n/a	n/a	0x88A8	1	x	SVID1	0x0800	x	x	GEM2	n/a	n/a	n/a	n/a	0x8100	1	n/a	CVID1	1		
C	MAC2	MAC1	n/a	n/a	n/a	n/a	0x88A8	2	x	SVID1	0x0800	x	x	GEM3	n/a	n/a	n/a	n/a	0x8100	2	n/a	CVID1	1		
D	MAC2	MAC1	n/a	n/a	n/a	n/a	0x88A8	3	x	SVID1	0x0800	x	x	GEM4	n/a	n/a	n/a	n/a	0x8100	3	n/a	CVID1	1		
E	MAC2	MAC1	n/a	n/a	n/a	n/a	0x88A8	4	x	SVID1	0x0800	x	x	GEM1	n/a	n/a	n/a	n/a	0x8100	4	n/a	CVID1	1		
F	MAC2	MAC1	n/a	n/a	n/a	n/a	0x88A8	5	x	SVID1	0x0800	x	x	GEM2	n/a	n/a	n/a	n/a	0x8100	5	n/a	CVID1	1		
G	MAC2	MAC1	n/a	n/a	n/a	n/a	0x88A8	6	x	SVID1	0x0800	x	x	GEM3	n/a	n/a	n/a	n/a	0x8100	6	n/a	CVID1	1		
H	MAC2	MAC1	n/a	n/a	n/a	n/a	0x88A8	7	x	SVID1	0x0800	x	x	GEM4	n/a	n/a	n/a	n/a	0x8100	7	n/a	CVID1	1		
I	MAC2	MAC1	n/a	n/a	n/a	n/a	0x88A8	0	x	SVID2	0x0800	x	x	GEM1	n/a	n/a	n/a	n/a	0x8100	1	n/a	CVID2	1		
J	MAC2	MAC1	n/a	n/a	n/a	n/a	0x88A8	1	x	SVID2	0x0800	x	x	GEM2	n/a	n/a	n/a	n/a	0x8100	2	n/a	CVID2	1		
H	MAC2	MAC1	n/a	n/a	n/a	n/a	0x88A8	2	x	SVID2	0x0800	x	x	GEM3	n/a	n/a	n/a	n/a	0x8100	3	n/a	CVID2	1		
I	MAC2	MAC1	n/a	n/a	n/a	n/a	0x88A8	3	x	SVID2	0x0800	x	x	GEM4	n/a	n/a	n/a	n/a	0x8100	4	n/a	CVID2	1		
J	MAC2	MAC1	n/a	n/a	n/a	n/a	0x88A8	4	x	SVID2	0x0800	x	x	GEM1	n/a	n/a	n/a	n/a	0x8100	5	n/a	CVID2	1		
K	MAC2	MAC1	n/a	n/a	n/a	n/a	0x88A8	5	x	SVID2	0x0800	x	x	GEM2	n/a	n/a	n/a	n/a	0x8100	6	n/a	CVID2	1		
L	MAC2	MAC1	n/a	n/a	n/a	n/a	0x88A8	6	x	SVID2	0x0800	x	x	GEM3	n/a	n/a	n/a	n/a	0x8100	7	n/a	CVID2	1		
M	MAC2	MAC1	n/a	n/a	n/a	n/a	0x88A8	7	x	SVID2	0x0800	x	x	GEM4	n/a	n/a	n/a	n/a	0x8100	0	n/a	CVID2	1		
N	MAC2	MAC1	n/a	n/a	n/a	n/a	0x88A8	0	x	SVID3	0x0800	x	x	GEM1	n/a	n/a	n/a	n/a	0x8100	2	n/a	CVID3	1		
O	MAC2	MAC1	n/a	n/a	n/a	n/a	0x88A8	1	x	SVID3	0x0800	x	x	GEM2	n/a	n/a	n/a	n/a	0x8100	3	n/a	CVID3	1		
P	MAC2	MAC1	n/a	n/a	n/a	n/a	0x88A8	2	x	SVID3	0x0800	x	x	GEM3	n/a	n/a	n/a	n/a	0x8100	4	n/a	CVID3	1		
Q	MAC2	MAC1	n/a	n/a	n/a	n/a	0x88A8	3	x	SVID3	0x0800	x	x	GEM4	n/a	n/a	n/a	n/a	0x8100	5	n/a	CVID3	1		
R	MAC2	MAC1	n/a	n/a	n/a	n/a	0x88A8	4	x	SVID3	0x0800	x	x	GEM1	n/a	n/a	n/a	n/a	0x8100	6	n/a	CVID3	1		
S	MAC2	MAC1	n/a	n/a	n/a	n/a	0x88A8	5	x	SVID3	0x0800	x	x	GEM2	n/a	n/a	n/a	n/a	0x8100	7	n/a	CVID3	1		
T	MAC2	MAC1	n/a	n/a	n/a	n/a	0x88A8	6	x	SVID3	0x0800	x	x	GEM3	n/a	n/a	n/a	n/a	0x8100	0	n/a	CVID3	1		
U	MAC2	MAC1	n/a	n/a	n/a	n/a	0x88A8	7	x	SVID3	0x0800	x	x	GEM4	n/a	n/a	n/a	n/a	0x8100	1	n/a	CVID3	1		
V	MAC2	MAC1	n/a	n/a	n/a	n/a	0x88A8	0	x	SVID4	0x0800	x	x	GEM1	n/a	n/a	n/a	n/a	0x8100	3	n/a	CVID4	1		
W	MAC2	MAC1	n/a	n/a	n/a	n/a	0x88A8	1	x	SVID4	0x0800	x	x	GEM2	n/a	n/a	n/a	n/a	0x8100	4	n/a	CVID4	1		
X	MAC2	MAC1	n/a	n/a	n/a	n/a	0x88A8	2	x	SVID4	0x0800	x	x	GEM3	n/a	n/a	n/a	n/a	0x8100	5	n/a	CVID4	1		
Y	MAC2	MAC1	n/a	n/a	n/a	n/a	0x88A8	3	x	SVID4	0x0800	x	x	GEM4	n/a	n/a	n/a	n/a	0x8100	6	n/a	CVID4	1		
Z	MAC2	MAC1	n/a	n/a	n/a	n/a	0x88A8	4	x	SVID4	0x0800	x	x	GEM1	n/a	n/a	n/a	n/a	0x8100	7	n/a	CVID4	1		

AA	MAC2	MAC1	n/a	n/a	n/a	n/a	0x88A8	5	x	SVID4	0x0800	x	x	GEM2	n/a	n/a	n/a	n/a	0x8100	0	n/a	CVID4	1
AB	MAC2	MAC1	n/a	n/a	n/a	n/a	0x88A8	6	x	SVID4	0x0800	x	x	GEM3	n/a	n/a	n/a	n/a	0x8100	1	n/a	CVID4	1
AC	MAC2	MAC1	n/a	n/a	n/a	n/a	0x88A8	7	x	SVID4	0x0800	x	x	GEM4	n/a	n/a	n/a	n/a	0x8100	2	n/a	CVID4	1
AD	MAC2	MAC1	n/a	n/a	n/a	n/a	0x88A8	0	x	SVID5	0x0800	x	x	GEM1	n/a	n/a	n/a	n/a	0x8100	4	n/a	CVID5	1
AE	MAC2	MAC1	n/a	n/a	n/a	n/a	0x88A8	1	x	SVID5	0x0800	x	x	GEM2	n/a	n/a	n/a	n/a	0x8100	5	n/a	CVID5	1
AF	MAC2	MAC1	n/a	n/a	n/a	n/a	0x88A8	2	x	SVID5	0x0800	x	x	GEM3	n/a	n/a	n/a	n/a	0x8100	6	n/a	CVID5	1
AG	MAC2	MAC1	n/a	n/a	n/a	n/a	0x88A8	3	x	SVID5	0x0800	x	x	GEM4	n/a	n/a	n/a	n/a	0x8100	7	n/a	CVID5	1
AH	MAC2	MAC1	n/a	n/a	n/a	n/a	0x88A8	4	x	SVID5	0x0800	x	x	GEM1	n/a	n/a	n/a	n/a	0x8100	0	n/a	CVID5	1
AI	MAC2	MAC1	n/a	n/a	n/a	n/a	0x88A8	5	x	SVID5	0x0800	x	x	GEM2	n/a	n/a	n/a	n/a	0x8100	1	n/a	CVID5	1
AJ	MAC2	MAC1	n/a	n/a	n/a	n/a	0x88A8	6	x	SVID5	0x0800	x	x	GEM3	n/a	n/a	n/a	n/a	0x8100	2	n/a	CVID5	1
AK	MAC2	MAC1	n/a	n/a	n/a	n/a	0x88A8	7	x	SVID5	0x0800	x	x	GEM4	n/a	n/a	n/a	n/a	0x8100	3	n/a	CVID5	1
AL	MAC2	MAC1	n/a	n/a	n/a	n/a	0x88A8	0	x	SVID6	0x0800	x	x	GEM1	n/a	n/a	n/a	n/a	0x8100	5	n/a	CVID6	1
AM	MAC2	MAC1	n/a	n/a	n/a	n/a	0x88A8	1	x	SVID6	0x0800	x	x	GEM2	n/a	n/a	n/a	n/a	0x8100	6	n/a	CVID6	1
AN	MAC2	MAC1	n/a	n/a	n/a	n/a	0x88A8	2	x	SVID6	0x0800	x	x	GEM3	n/a	n/a	n/a	n/a	0x8100	7	n/a	CVID6	1
AO	MAC2	MAC1	n/a	n/a	n/a	n/a	0x88A8	3	x	SVID6	0x0800	x	x	GEM4	n/a	n/a	n/a	n/a	0x8100	0	n/a	CVID6	1
AP	MAC2	MAC1	n/a	n/a	n/a	n/a	0x88A8	4	x	SVID6	0x0800	x	x	GEM1	n/a	n/a	n/a	n/a	0x8100	1	n/a	CVID6	1
AQ	MAC2	MAC1	n/a	n/a	n/a	n/a	0x88A8	5	x	SVID6	0x0800	x	x	GEM2	n/a	n/a	n/a	n/a	0x8100	2	n/a	CVID6	1
AR	MAC2	MAC1	n/a	n/a	n/a	n/a	0x88A8	6	x	SVID6	0x0800	x	x	GEM3	n/a	n/a	n/a	n/a	0x8100	3	n/a	CVID6	1
AS	MAC2	MAC1	n/a	n/a	n/a	n/a	0x88A8	7	x	SVID6	0x0800	x	x	GEM4	n/a	n/a	n/a	n/a	0x8100	4	n/a	CVID6	1
AT	MAC2	MAC1	n/a	n/a	n/a	n/a	0x88A8	0	x	SVID7	0x0800	x	x	GEM1	n/a	n/a	n/a	n/a	0x8100	6	n/a	CVID7	1
AU	MAC2	MAC1	n/a	n/a	n/a	n/a	0x88A8	1	x	SVID7	0x0800	x	x	GEM2	n/a	n/a	n/a	n/a	0x8100	7	n/a	CVID7	1
AV	MAC2	MAC1	n/a	n/a	n/a	n/a	0x88A8	2	x	SVID7	0x0800	x	x	GEM3	n/a	n/a	n/a	n/a	0x8100	0	n/a	CVID7	1
AW	MAC2	MAC1	n/a	n/a	n/a	n/a	0x88A8	3	x	SVID7	0x0800	x	x	GEM4	n/a	n/a	n/a	n/a	0x8100	1	n/a	CVID7	1
AX	MAC2	MAC1	n/a	n/a	n/a	n/a	0x88A8	4	x	SVID7	0x0800	x	x	GEM1	n/a	n/a	n/a	n/a	0x8100	2	n/a	CVID7	1
AY	MAC2	MAC1	n/a	n/a	n/a	n/a	0x88A8	5	x	SVID7	0x0800	x	x	GEM2	n/a	n/a	n/a	n/a	0x8100	3	n/a	CVID7	1
AZ	MAC2	MAC1	n/a	n/a	n/a	n/a	0x88A8	6	x	SVID7	0x0800	x	x	GEM3	n/a	n/a	n/a	n/a	0x8100	4	n/a	CVID7	1
BA	MAC2	MAC1	n/a	n/a	n/a	n/a	0x88A8	7	x	SVID7	0x0800	x	x	GEM4	n/a	n/a	n/a	n/a	0x8100	5	n/a	CVID7	1
BB	MAC2	MAC1	n/a	n/a	n/a	n/a	0x88A8	0	x	SVID8	0x0800	x	x	GEM1	n/a	n/a	n/a	n/a	0x8100	7	n/a	CVID8	1
BC	MAC2	MAC1	n/a	n/a	n/a	n/a	0x88A8	1	x	SVID8	0x0800	x	x	GEM2	n/a	n/a	n/a	n/a	0x8100	0	n/a	CVID8	1
BD	MAC2	MAC1	n/a	n/a	n/a	n/a	0x88A8	2	x	SVID8	0x0800	x	x	GEM3	n/a	n/a	n/a	n/a	0x8100	1	n/a	CVID8	1
BE	MAC2	MAC1	n/a	n/a	n/a	n/a	0x88A8	3	x	SVID8	0x0800	x	x	GEM4	n/a	n/a	n/a	n/a	0x8100	2	n/a	CVID8	1
BF	MAC2	MAC1	n/a	n/a	n/a	n/a	0x88A8	4	x	SVID8	0x0800	x	x	GEM1	n/a	n/a	n/a	n/a	0x8100	3	n/a	CVID8	1
BH	MAC2	MAC1	n/a	n/a	n/a	n/a	0x88A8	5	x	SVID8	0x0800	x	x	GEM2	n/a	n/a	n/a	n/a	0x8100	4	n/a	CVID8	1
BI	MAC2	MAC1	n/a	n/a	n/a	n/a	0x88A8	6	x	SVID8	0x0800	x	x	GEM3	n/a	n/a	n/a	n/a	0x8100	5	n/a	CVID8	1
BJ	MAC2	MAC1	n/a	n/a	n/a	n/a	0x88A8	7	x	SVID8	0x0800	x	x	GEM4	n/a	n/a	n/a	n/a	0x8100	6	n/a	CVID8	1

Test Procedure

1. Select distinct random values for CVID1 through CVID8 and SVID1 through SVID8 between 1 and 4094.
2. Select distinct random values for unicast MAC addresses MAC1 and MAC2
3. Cause the OLT Emulator to send the configured OMCI message sequence to provision the ONU.
4. Inject tagged traffic at the U-interface with the specified P-bit values and random VID values.
5. Inject tagged traffic at the S/R-interface with the specified P-bit values and random VID values.

OMCI Procedure Details

Refer to clause 4.3.

Pass/Fail Criteria

The test passes if the following are true, otherwise the test fails:

1. All OMCI commands have Success responses at step 3
2. Verify at step 4 that P-bit values are correctly mapped into the right GEM ports at the S/R-interface
3. Verify at step 4 that VID and P-bit are translated as per table defined in test configuration step 4
4. Verify at step 5 that VID and P-bit are translated as per table defined in test configuration step 4

Remarks

- None.

6.1.29 Verifying MAC Address is not used as a Classification Criterion

Test Name

Verifying MAC Address is not used as a Classification Criterion

Test Definition Number

ONU.6.1.29

Reference Document

BBF TR-156 [20]

ITU-T G.988 [6][7][8]

Test Type

Conformance

Test Requirement Type

Mandatory

Unit Under Test

ONU

Requirement Description

BBF TR-156:

- **R-48** The ONU MUST support deriving P-bit markings in the upstream direction based on an arbitrary combination of: user port, VID, received P-bit markings, and EtherType.
- **R-51** The ONU MUST support mapping traffic into GEM Ports based on arbitrary combination of user port, VID and P-bit values in the upstream direction
- **Also, R-6, R-7, R-50.**

Note: Section 5.1/TR-156 states the following:

“On U interface ingress, traffic is classified into VLANs with various Ethernet priorities based on a number of criteria: physical port, VID, VLAN P-bits, EtherType and/or DSCP. Any combination of these criteria can be used to determine the Ethernet priority. The VID and EtherType can be used to determine the new VID. Once the traffic has been assigned a VLAN and Ethernet precedence, these two Ethernet header components are used to select an upstream GEM Port so that proper QoS can be applied to the flows.”

This indicates a TR-156 compliant ONU should not use other information, such as MAC addresses in the Ethernet frames, as the classification criteria.

Test Objective

Verify that the ONU does not use source or destination MAC addresses or any combination of MAC address with physical port, VID, VLAN P-bits, EtherType and/or DSCP as the classification criteria.

Test Configuration

1. OLT Emulator and ONU under test are powered and connected to ODN
2. ONU under test has been activated by the OLT Emulator, has been ranged, and a GEM port for OMCI has been created as a result of ONU-ID assignment.
3. The OLT Emulator configure through OMCI the ONU under test:
 - To support 2 traffic class (i.e., P-bit mapping)
 - With 2 GEM port and 2 downstream queue for each traffic class
4. The Ethernet Traffic Generator and the OLT Emulator will be configured to transmit flows of double-tagged Ethernet frames with the parameters in the next table. Also, GEM port mapping is shown

Upstream Direction																								
Traffic Stream	U Interface													R/S Interface										
	UNI	MAC DA	MAC SA	Outer VLAN Tag				Inner VLAN Tag				Ethertype	IP DA	IP SA	Outer VLAN Tag				Inner VLAN Tag				GEM	T-CONT
	Port #	Value	Value	TPID	Pbits	DEI	VID	TPID	Pbits	CFI or DEI	VID	Value	Value	Value	TPID	Pbits	DEI	VID	TPID	Pbits	CFI or DEI	VID	Port #	Number
Aus	1	MAC1	MAC2	n/a	n/a	n/a	n/a	0x8100	CPbit1	n/a	CVID1	0x0800	x	x	n/a	n/a	n/a	n/a	0x88A8	SPbit1	x	SVID1	GEM1	TCONT1
Bus	1	MAC1	MAC2	n/a	n/a	n/a	n/a	0x8100	CPbit2	n/a	CVID1	0x0800	x	x	n/a	n/a	n/a	n/a	0x88A8	SPbit2	x	SVID1	GEM1	TCONT1
Cus	1	MAC1	MAC2	n/a	n/a	n/a	n/a	0x8100	CPbit3	n/a	CVID2	0x0800	x	x	n/a	n/a	n/a	n/a	0x88A8	SPbit3	x	SVID2	GEM2	TCONT2
Dus	1	MAC1	MAC2	n/a	n/a	n/a	n/a	0x8100	CPbit3	n/a	CVID3	0x0800	x	x	n/a	n/a	n/a	n/a	0x88A8	SPbit3	x	SVID3	GEM2	TCONT2
Eus	1	MAC3	MAC4	n/a	n/a	n/a	n/a	0x8100	CPbit1	n/a	CVID1	0x0800	x	x	n/a	n/a	n/a	n/a	0x88A8	SPbit1	x	SVID1	GEM1	TCONT1
Fus	1	MAC5	MAC6	n/a	n/a	n/a	n/a	0x8100	CPbit3	n/a	CVID3	0x0800	x	x	n/a	n/a	n/a	n/a	0x88A8	SPbit3	x	SVID3	GEM2	TCONT2
Gus	1	MAC7	MAC8	n/a	n/a	n/a	n/a	0x8100	CPbit2	n/a	CVID1	0x0800	x	x	n/a	n/a	n/a	n/a	0x88A8	SPbit2	x	SVID1	GEM1	TCONT1
Hus	1	MAC7	MAC8	n/a	n/a	n/a	n/a	0x8100	CPbit3	n/a	CVID2	0x0800	x	x	n/a	n/a	n/a	n/a	0x88A8	SPbit3	x	SVID2	GEM2	TCONT2

Downstream Direction																							
Traffic Stream	S/R Interface														U Interface								
	MAC DA	MAC SA	Outer VLAN Tag				Inner VLAN Tag				Ethertype	IP DA	IP SA	GEM	Outer VLAN Tag				Inner VLAN Tag				UNI
	Value	Value	TPID	Pbits	DEI	VID	TPID	Pbits	CFI or DEI	VID	Value	Value	Value	Port #	TPID	Pbits	DEI	VID	TPID	Pbits	CFI or DEI	VID	Port #
Ads	MAC2	MAC1	n/a	n/a	n/a	n/a	0x88A8	SPbit1	x	SVID1	0x0800	x	x	GEM1	n/a	n/a	n/a	n/a	0x8100	CPbit1	n/a	CVID1	1
Bds	MAC2	MAC1	n/a	n/a	n/a	n/a	0x88A8	SPbit2	x	SVID1	0x0800	x	x	GEM1	n/a	n/a	n/a	n/a	0x8100	CPbit2	n/a	CVID1	1
Cds	MAC2	MAC1	n/a	n/a	n/a	n/a	0x88A8	SPbit3	x	SVID2	0x0800	x	x	GEM2	n/a	n/a	n/a	n/a	0x8100	CPbit3	n/a	CVID2	1
Dds	MAC2	MAC1	n/a	n/a	n/a	n/a	0x88A8	SPbit3	x	SVID3	0x0800	x	x	GEM2	n/a	n/a	n/a	n/a	0x8100	CPbit3	n/a	CVID3	1
Eds	MAC4	MAC3	n/a	n/a	n/a	n/a	0x88A8	SPbit1	x	SVID1	0x0800	x	x	GEM1	n/a	n/a	n/a	n/a	0x8100	CPbit1	n/a	CVID1	1
Fds	MAC6	MAC5	n/a	n/a	n/a	n/a	0x88A8	SPbit3	x	SVID3	0x0800	x	x	GEM2	n/a	n/a	n/a	n/a	0x8100	CPbit3	n/a	CVID3	1
Gds	MAC8	MAC7	n/a	n/a	n/a	n/a	0x88A8	SPbit2	x	SVID1	0x0800	x	x	GEM1	n/a	n/a	n/a	n/a	0x8100	CPbit2	n/a	CVID1	1
Hds	MAC8	MAC7	n/a	n/a	n/a	n/a	0x88A8	SPbit3	x	SVID2	0x0800	x	x	GEM2	n/a	n/a	n/a	n/a	0x8100	CPbit3	n/a	CVID2	1

Test Procedure

1. Select distinct random values for MAC address: MAC1 to MAC8
2. Select distinct random values for CVID1, CVID2, CVID3, SVID1, SVID2 and SVID3 between 1 and 4094.
3. Select distinct random values for CPbit1, CPbit2, CPbit3, SPbit1, SPbit2 and SPbit3.
4. Cause the OLT Emulator to send the configured OMCI message sequence to provision the ONU
5. launch traffic from A_{ds} to H_{ds} in downstream direction
6. launch traffic from A_{us} to H_{us} in upstream direction
7. Stop all traffic in both direction

OMCI Procedure Details

Refer to clause 4.3.

Pass/Fail Criteria

The test passes if the following are true, otherwise the test fails:

1. All OMCI commands have Success responses
2. The ONU is able to forward all flows in downstream direction without any packets lost at step 5
3. The ONU is able to forward all flows in upstream direction without any packets lost at step 6

Remarks

- None.

6.1.30 Downstream Translation for Code Point 0

Test Name

Downstream Translation for Code Point 0

Test Definition Number

ONU.6.1.30

Reference Document

BBF TR-280 [23]

ITU-T G.988 [6][7][8]

Test Type

Conformance

Test Requirement Type

Mandatory

Unit Under Test

ONU

Requirement Description**BBF TR-280**

- **[R-61]** The ONU MUST support all actual code points (0 to 8) for the downstream mode attribute of the Extended VLAN tagging operation configuration data ME [ITU-T G.988]

Note: Unmatched frames will not be tested as their handlings are left to the implementation of the ONU

Test Objective

Verify that the ONU is able to perform downstream translation for the code point 0 (The operation performed in the downstream direction is the inverse of that performed in the upstream direction. Which treatment and filter fields are used for downstream filtering and the handling of unmatched frames are left to the implementation of the ONU).

Test Configuration

Note: Traffic flows definitions and names are consistent across tests 6.1.30 to 6.1.38 ("*downstream translation for Code Point x*"). In a given test case, some flows may be omitted and VID and P-bit values may not use the full declared range.

1. OLT Emulator and ONU under test are powered and connected to ODN
2. ONU activation and OMCC establishment processes have been successfully completed.
3. The Ethernet Traffic Generator and the OLT Emulator will be configured to transmit four interleaved flows of Ethernet frames with the parameters in the next table in upstream. Also, GEM port/T-CONT mapping is shown.

Upstream Direction																								
Traffic Stream	U Interface													R/S Interface										
	UNI	MAC DA	MAC SA	Outer VLAN Tag				Inner VLAN Tag				Ethertype	IP DA	IP SA	Outer VLAN Tag				Inner VLAN Tag				GEM	T-CONT
	Port #	Value	Value	TPID	Pbits	DEI	VID	TPID	Pbits	CFI or DEI	VID	Value	Value	Value	TPID	Pbits	DEI	VID	TPID	Pbits	CFI or DEI	VID	Port #	Number
A	1	MAC1	MAC2	n/a	n/a	n/a	n/a	0x8100	CPbit1	n/a	CVID1	0x0800	x	x	n/a	n/a	n/a	n/a	0x8100	SPbit1	x	SVID1	GEM1	TCONT1
B	1	MAC1	MAC2	n/a	n/a	n/a	n/a	0x8100	CPbit3	n/a	CVID2	0x0800	x	x	n/a	n/a	n/a	n/a	0x8100	SPbit2	x	SVID1	GEM2	TCONT2
C	1	MAC1	MAC2	n/a	n/a	n/a	n/a	0x8100	CPbit4	n/a	CVID3	0x0800	x	x	n/a	n/a	n/a	n/a	0x8100	SPbit3	x	SVID2	GEM3	TCONT3
D	1	MAC1	MAC2	n/a	n/a	n/a	n/a	0x8100	CPbit6	n/a	CVID5	0x0800	x	x	n/a	n/a	n/a	n/a	0x8100	SPbit4	x	SVID3	GEM4	TCONT4

4. The Traffic generator will be configured to transmit four interleaved flows of Ethernet frames with the parameters in the next table in downstream. Also, GEM port mapping is shown.

Downstream Direction																							
Traffic Stream	S/R Interface														U Interface								
	MAC DA	MAC SA	Outer VLAN Tag				Inner VLAN Tag				Ethertype	IP DA	IP SA	GEM	Outer VLAN Tag				Inner VLAN Tag			UNI	
	Value	Value	TPID	Pbits	DEI	VID	TPID	Pbits	CFI or DEI	VID	Value	Value	Value	Port #	TPID	Pbits	DEI	VID	TPID	Pbits	CFI or DEI	VID	Port #
A	MAC2	MAC1	n/a	n/a	n/a	n/a	0x8100	SPbit1	x	SVID1	0x0800	x	x	GEM1	n/a	n/a	n/a	n/a	0x8100	CPbit1	n/a	CVID1	1
B	MAC2	MAC1	n/a	n/a	n/a	n/a	0x8100	SPbit2	x	SVID1	0x0800	x	x	GEM2	n/a	n/a	n/a	n/a	0x8100	CPbit3	n/a	CVID2	1
C	MAC2	MAC1	n/a	n/a	n/a	n/a	0x8100	SPbit3	x	SVID2	0x0800	x	x	GEM3	n/a	n/a	n/a	n/a	0x8100	CPbit4	n/a	CVID3	1
D	MAC2	MAC1	n/a	n/a	n/a	n/a	0x8100	SPbit4	x	SVID3	0x0800	x	x	GEM4	n/a	n/a	n/a	n/a	0x8100	CPbit6	n/a	CVID5	1

5. The OLT Emulator will be configured to send the sequence of OMCI messages required to provision the ONU under test
 - to support 4 traffic class, each one associated to a different P-bit value (i.e., P-bit mapping)
 - with 4 GEM ports and 4 downstream queues, each pair of GEM port-downstream queue assigned to one traffic class

Test Procedure

1. Select distinct random values for CVID1 through CVID5 and SVID1 through SVID3 between 1 and 4094.
2. Select distinct random values for CPbit1 through CPbit6 and random distinct values for SPbit1 through SPbit4.
3. Select distinct random values for unicast MAC addresses MAC1 through MAC2
4. Cause the OLT Emulator to send the configured OMCI message sequence to provision the ONU.

5. Enable any frame capture mechanism on the OLT Emulator and the Ethernet traffic generator
6. Cause the OLT Emulator and Ethernet traffic generator to transmit the frames defined above
7. Verify that VID and P-bit values are correctly mapping into the right GEM ports and T-CONTs at the S/R-interface
8. Verify that VID and P-bit values are correctly translating into the right VID and P-bit at the S/R interface
9. Verify that VID and P-bit values are correctly translating into the right VID and P-bit at the U-interface

OMCI Procedure Details

Refer to clause 4.3.

Pass/Fail Criteria

The test passes if the following are true, otherwise the test fails:

1. All OMCI commands have Success responses at step 4
2. At step 7, for each flow in the upstream direction, the resulting GEM port/T-CONT match the specifications detailed in the traffic table defined in configuration step 3
3. At step 8, for each flow in upstream direction, VID and P-bit values are correctly translating into the right VID and P-bit at the S/R interface, as defined in the traffic table from configuration step 3.
4. At step 9, for each flow in downstream direction, VID and P-bit values are correctly translating into the right VID and P-bit at the U interface, as defined in the traffic table from configuration step 4.

Remarks

- None.

6.1.31 Downstream Translation for Code Point 1

Test Name

Downstream Translation for Code Point 1

Test Definition Number

ONU.6.1.31

Reference Document

BBF TR-280 [23]

ITU-T G.988 [6][7][8]

Test Type

Conformance

Test Requirement Type

Mandatory

Unit Under Test

ONU

Requirement Description**BBF TR-280**

- **[R-61]** The ONU MUST support all actual code points (0 to 8) for the downstream mode attribute of the Extended VLAN tagging operation configuration data ME [ITU-T G.988]

Test Objective

Verify that the ONU is able to perform downstream translation for the code point 1 (Regardless of the filter rules, no operation is performed in the downstream direction. All downstream frames are forwarded unmodified).

Test Configuration

Note: Traffic flows definitions and names are consistent across tests 6.1.30 to 6.1.38 ("*downstream translation for Code Point x*"). In a given test case, some flows may be omitted and VID and P-bit values may not use the full declared range.OLT Emulator and ONU under test are powered and connected to ODN

1. ONU activation and OMCC establishment processes have been successfully completed.

- The Traffic generator will be configured to transmit five interleaved flows of Ethernet frames with the parameters in the next table in upstream. Also, GEM port/T-CONT mapping is shown.

Upstream Direction																								
Traffic Stream	U Interface													R/S Interface										
	UNI	MAC DA	MAC SA	Outer VLAN Tag				Inner VLAN Tag				Ethertype	IP DA	IP SA	Outer VLAN Tag				Inner VLAN Tag				GEM	T-CONT
	Port #	Value	Value	TPID	Pbits	DEI	VID	TPID	Pbits	CFI or DEI	VID	Value	Value	Value	TPID	Pbits	DEI	VID	TPID	Pbits	CFI or DEI	VID	Port #	Number
A	1	MAC1	MAC2	n/a	n/a	n/a	n/a	0x8100	CPBIT1	n/a	CVID1	0x0800	x	x	n/a	n/a	n/a	n/a	0x8100	SPBIT1	x	SVID1	GEM1	TCONT1
B	1	MAC1	MAC2	n/a	n/a	n/a	n/a	0x8100	CPBIT3	n/a	CVID1	0x0800	x	x	n/a	n/a	n/a	n/a	0x8100	SPBIT2	x	SVID1	GEM2	TCONT2
C	1	MAC1	MAC2	n/a	n/a	n/a	n/a	0x8100	CPBIT4	n/a	CVID3	0x0800	x	x	n/a	n/a	n/a	n/a	0x8100	SPBIT3	x	SVID2	GEM3	TCONT3
D	1	MAC1	MAC2	n/a	n/a	n/a	n/a	0x8100	CPBIT6	n/a	CVID5	0x0800	x	x	n/a	n/a	n/a	n/a	0x8100	SPBIT4	x	SVID3	GEM4	TCONT4
E	1	MAC1	MAC2	n/a	n/a	n/a	n/a	0x8100	SPBIT3	n/a	SVID3	0x0800	x	x	n/a	n/a	n/a	n/a	0x8100	SPBIT3	x	SVID3	GEM3	TCONT3

Note: For the flow E, no specific rule is applied, only the upstream default rule is used.

- The Traffic generator will be configured to transmit nine interleaved flows of Ethernet frames with the parameters in the next table in downstream. Also, GEM port mapping is shown.

Downstream Direction																							
Traffic Stream	S/R Interface														U Interface								
	MAC DA	MAC SA	Outer VLAN Tag				Inner VLAN Tag				Ethertype	IP DA	IP SA	GEM	Outer VLAN Tag				Inner VLAN Tag				UNI
	Value	Value	TPID	Pbits	DEI	VID	TPID	Pbits	CFI or DEI	VID	Value	Value	Value	Port #	TPID	Pbits	DEI	VID	TPID	Pbits	CFI or DEI	VID	Port #
A	MAC2	MAC1	n/a	n/a	n/a	n/a	0x8100	SPBIT1	x	SVID1	0x0800	x	x	GEM1	n/a	n/a	n/a	n/a	0x8100	SPBIT1	n/a	SVID1	1
B	MAC2	MAC1	n/a	n/a	n/a	n/a	0x8100	SPBIT2	x	SVID1	0x0800	x	x	GEM2	n/a	n/a	n/a	n/a	0x8100	SPBIT2	n/a	SVID1	1
C	MAC2	MAC1	n/a	n/a	n/a	n/a	0x8100	SPBIT3	x	SVID2	0x0800	x	x	GEM3	n/a	n/a	n/a	n/a	0x8100	SPBIT3	n/a	SVID2	1
D	MAC2	MAC1	n/a	n/a	n/a	n/a	0x8100	SPBIT4	x	SVID3	0x0800	x	x	GEM4	n/a	n/a	n/a	n/a	0x8100	SPBIT4	n/a	SVID3	1
E	MAC2	MAC1	n/a	n/a	n/a	n/a	0x8100	SPBIT3	x	SVID3	0x0800	x	x	GEM3	n/a	n/a	n/a	n/a	0x8100	SPBIT3	n/a	SVID3	1
F	MAC2	MAC1	n/a	n/a	n/a	n/a	0x8100	SPBIT1	x	SVID4	0x0800	x	x	GEM1	n/a	n/a	n/a	n/a	0x8100	SPBIT1	n/a	SVID4	1
G	MAC2	MAC1	n/a	n/a	n/a	n/a	0x8100	SPBIT5	x	SVID4	0x0800	x	x	GEM4	n/a	n/a	n/a	n/a	0x8100	SPBIT5	n/a	SVID4	1
H	MAC2	MAC1	n/a	n/a	n/a	n/a	0x8100	SPBIT1	x	SVID2	0x0800	x	x	GEM1	n/a	n/a	n/a	n/a	0x8100	SPBIT1	n/a	SVID2	1
I	MAC2	MAC1	n/a	n/a	n/a	n/a	0x8100	SPBIT6	x	SVID5	0x0800	x	x	GEM2	n/a	n/a	n/a	n/a	0x8100	SPBIT6	n/a	SVID5	1

Note: Flow E, F, G, H, and I do not have corresponding specific upstream rules configured in OMCI.

- The OLT Emulator will be configured to send the sequence of OMCI messages required to provision the ONU under test
 - to support 4 traffic class, each one associated to different P-bit values (i.e., P-bit mapping)
 - with 4 GEM ports and 4 downstream queues, each pair of GEM port-downstream queue assigned to one traffic class

Test Procedure

- Select distinct random values for CVID1 through CVID5 and SVID1 through SVID5 between 1 and 4094.

2. Select distinct random values for CPbit1 through CPbit6 and random distinct values for SPbit1 through SPbit6.
3. Select distinct random values for unicast MAC addresses MAC1 through MAC2
4. Cause the OLT Emulator to send the configured OMCI message sequence to provision the ONU.
5. Enable any frame capture mechanism on the OLT Emulator and the Ethernet traffic generator
6. Cause the OLT Emulator and Ethernet traffic generator to transmit the frames defined above
7. Verify that VID and P-bit values are correctly mapping into the right GEM ports and T-CONTs at the S/R-interface
8. Verify that VID and P-bit values are correctly translating into the right VID and P-bit at the S/R interface
9. Verify that flow A to I are forwarded at the U interface in downstream direction without any frames modification.

OMCI Procedure Details

Refer to clause 4.3.

Pass/Fail Criteria

The test passes if the following are true, otherwise the test fails:

1. All OMCI commands have Success responses at step 4
2. At step 7, for each flow in the upstream direction, the resulting GEM port/T-CONT match the specifications detailed in the traffic table defined in configuration step 3
3. At step 8, for each flow in upstream direction, VID and P-bit values are correctly translating into the right VID and P-bit at the S/R interface, as defined in the traffic table from configuration step 3.
4. At step 9, for each flow in downstream direction, VID and P-bit values are forwarded without any modification at the U interface, as defined in the traffic table from configuration step 4.

Remarks

- None.

6.1.32 Downstream Translation for Code Point 2

Test Name

Downstream Translation for Code Point 2

Test Definition Number

ONU.6.1.32

Reference Document

BBF TR-280 [23]

ITU-T G.988 [6][7][8]

Test Type

Conformance

Test Requirement Type

Mandatory

Unit Under Test

ONU

Requirement Description

BBF TR-280

- [R-61] The ONU MUST support all actual code points (0 to 8) for the downstream mode attribute of the Extended VLAN tagging operation configuration data ME [ITU-T G.988]

Test Objective

Verify that the ONU is able to perform downstream translation for the code point 2 (Filter on VID and p-bit value. On a match, perform the inverse operation on both the VID and p-bit value. If no match is found, forward the frame unmodified).

Test Configuration

Note: Traffic flows definitions and names are consistent across tests 6.1.30 to 6.1.38 ("*downstream translation for Code Point x*"). In a given test case, some flows may be omitted and VID and P-bit values may not use the full declared range.

1. OLT Emulator and ONU under test are powered and connected to ODN
2. ONU activation and OMCC establishment processes have been successfully completed.

- The Ethernet Traffic Generator and the OLT Emulator will be configured to transmit five interleaved flows of Ethernet frames with the parameters in the next table. Also, GEM port/T-CONT mapping is shown.

Upstream Direction																								
Traffic Stream	U Interface													R/S Interface										
	UNI	MAC DA	MAC SA	Outer VLAN Tag				Inner VLAN Tag				Ethertype	IP DA	IP SA	Outer VLAN Tag				Inner VLAN Tag				GEM	T-CONT
	Port #	Value	Value	TPID	Pbits	DEI	VID	TPID	Pbits	CFI or DEI	VID	Value	Value	Value	TPID	Pbits	DEI	VID	TPID	Pbits	CFI or DEI	VID	Port #	Number
A	1	MAC1	MAC2	n/a	n/a	n/a	n/a	0x8100	CPBIT1	n/a	CVID1	0x0800	x	x	n/a	n/a	n/a	n/a	0x8100	SPBIT1	x	SVID1	GEM1	TCONT1
B	1	MAC1	MAC2	n/a	n/a	n/a	n/a	0x8100	CPBIT3	n/a	CVID2	0x0800	x	x	n/a	n/a	n/a	n/a	0x8100	SPBIT2	x	SVID1	GEM2	TCONT2
C	1	MAC1	MAC2	n/a	n/a	n/a	n/a	0x8100	CPBIT4	n/a	CVID3	0x0800	x	x	n/a	n/a	n/a	n/a	0x8100	SPBIT3	x	SVID2	GEM3	TCONT3
D	1	MAC1	MAC2	n/a	n/a	n/a	n/a	0x8100	CPBIT6	n/a	CVID5	0x0800	x	x	n/a	n/a	n/a	n/a	0x8100	SPBIT4	x	SVID3	GEM4	TCONT4
E	1	MAC1	MAC2	n/a	n/a	n/a	n/a	0x8100	SPBIT3	n/a	SVID3	0x0800	x	x	n/a	n/a	n/a	n/a	0x8100	SPBIT3	x	SVID3	GEM3	TCONT3

Note: For the flow E, no specific rule is applied, only the upstream default rule is used.

- The Traffic generator and the OLT Emulator will be configured to transmit nine interleaved flows of Ethernet frames with the parameters in the next table in downstream. Also, GEM port mapping is shown.

Downstream Direction																								
Traffic Stream	S/R Interface													U Interface										
	MAC DA	MAC SA	Outer VLAN Tag				Inner VLAN Tag				Ethertype	IP DA	IP SA	GEM	Outer VLAN Tag				Inner VLAN Tag				UNI	
	Value	Value	TPID	Pbits	DEI	VID	TPID	Pbits	CFI or DEI	VID	Value	Value	Value	Port #	TPID	Pbits	DEI	VID	TPID	Pbits	CFI or DEI	VID	Port #	
A	MAC2	MAC1	n/a	n/a	n/a	n/a	0x8100	SPbit1	x	SVID1	0x0800	x	x	GEM1	n/a	n/a	n/a	n/a	0x8100	CPbit1	n/a	CVID1	1	
B	MAC2	MAC1	n/a	n/a	n/a	n/a	0x8100	SPbit2	x	SVID1	0x0800	x	x	GEM2	n/a	n/a	n/a	n/a	0x8100	CPbit3	n/a	CVID2	1	
C	MAC2	MAC1	n/a	n/a	n/a	n/a	0x8100	SPbit3	x	SVID2	0x0800	x	x	GEM3	n/a	n/a	n/a	n/a	0x8100	CPbit4	n/a	CVID3	1	
D	MAC2	MAC1	n/a	n/a	n/a	n/a	0x8100	SPbit4	x	SVID3	0x0800	x	x	GEM4	n/a	n/a	n/a	n/a	0x8100	CPbit6	n/a	CVID5	1	
E	MAC2	MAC1	n/a	n/a	n/a	n/a	0x8100	SPbit3	x	SVID3	0x0800	x	x	GEM3	n/a	n/a	n/a	n/a	0x8100	SPbit3	n/a	SVID3	1	
F	MAC2	MAC1	n/a	n/a	n/a	n/a	0x8100	SPbit1	x	SVID4	0x0800	x	x	GEM1	n/a	n/a	n/a	n/a	0x8100	SPbit1	n/a	SVID4	1	
G	MAC2	MAC1	n/a	n/a	n/a	n/a	0x8100	SPbit5	x	SVID4	0x0800	x	x	GEM4	n/a	n/a	n/a	n/a	0x8100	SPbit5	n/a	SVID4	1	
H	MAC2	MAC1	n/a	n/a	n/a	n/a	0x8100	SPbit1	x	SVID2	0x0800	x	x	GEM1	n/a	n/a	n/a	n/a	0x8100	SPbit1	n/a	SVID2	1	
I	MAC2	MAC1	n/a	n/a	n/a	n/a	0x8100	SPbit6	x	SVID5	0x0800	x	x	GEM2	n/a	n/a	n/a	n/a	0x8100	SPbit6	n/a	SVID5	1	

Note: Flow E, F, G, H, and I do not have corresponding specific upstream rules configured in OMCI.

- The OLT Emulator will be configured to send the sequence of OMCI messages required to provision the ONU under test
 - to support 4 traffic class, each one associated to a different P-bit value (i.e., P-bit mapping)
 - with 4 GEM ports and 4 downstream queues, each pair of GEM port-downstream queue assigned to one traffic class

Test Procedure

- Select distinct random values for CVID1 through CVID5 and SVID1 through SVID5 between 1 and 4094.

2. Select distinct random values for CPbit1 through CPbit6 and random distinct values for SPbit1 through SPbit6.
3. Select distinct random values for unicast MAC addresses MAC1 through MAC2
4. Cause the OLT Emulator to send the configured OMCI message sequence to provision the ONU.
5. Enable any frame capture mechanism on the OLT Emulator and the Ethernet traffic generator
6. Cause the OLT Emulator and Ethernet traffic generator to transmit the frames defined above
7. Verify that VID and P-bit values are correctly mapping into the right GEM ports and T-CONTs at the S/R-interface
8. Verify that VID and P-bit values are correctly translating into the right VID and P-bit at the S/R interface
9. Verify that VID and P-bit values are correctly translating into the right VID and P-bit at the U-interface
10. Verify that flow E, F, G, H and I are forwarded at the U interface in downstream direction without any frames modification.

OMCI Procedure Details

Refer to clause 4.3.

Pass/Fail Criteria

The test passes if the following are true, otherwise the test fails:

1. All OMCI commands have Success responses at step 4
2. At step 7, for each flow in the upstream direction, the resulting GEM port/T-CONT match the specifications detailed in the traffic table defined in configuration step 3
3. At step 8, for each flow in upstream direction, VID and P-bit values are correctly translating into the right VID and P-bit at the S/R interface, as defined in the traffic table from configuration step 3.
4. At step 9, for each flow in downstream direction, VID and P-bit values are correctly translating into the right VID and P-bit at the U interface, as defined in the traffic table from configuration step 4.
5. The flow E, F, G, H and I in downstream are forwarded without any modification at the ONU U interface at step 10

Remarks

- None.

6.1.33 Downstream Translation for Code Point 3

Test Name

Downstream Translation for Code Point 3

Test Definition Number

ONU.6.1.33

Reference Document

BBF TR-280 [23]

ITU-T G.988 [6][7][8]

Test Type

Conformance

Test Requirement Type

Mandatory

Unit Under Test

ONU

Requirement Description

BBF TR-280

- [R-61] The ONU MUST support all actual code points (0 to 8) for the downstream mode attribute of the Extended VLAN tagging operation configuration data ME [ITU-T G.988]

Test Objective

Verify that the ONU is able to perform downstream translation for the code point 3 (Filter on VID only. On a match, perform the inverse VID operation only; pass the p bits through. If no match is found, forward the frame unmodified).

Test Configuration

Note: Traffic flows definitions and names are consistent across tests 6.1.30 to 6.1.38 ("*downstream translation for Code Point x*"). In a given test case, some flows may be omitted and VID and P-bit values may not use the full declared range.

1. OLT Emulator and ONU under test are powered and connected to ODN
2. ONU activation and OMCC establishment processes have been successfully completed.

- The traffic generator will be configured to transmit five interleaved flows of Ethernet frames with the parameters in the next table in upstream. Also, GEM port/T-CONT mapping is shown.

Upstream Direction																								
Traffic Stream	U Interface													R/S Interface										
	UNI	MAC DA	MAC SA	Outer VLAN Tag				Inner VLAN Tag				Ethertype	IP DA	IP SA	Outer VLAN Tag				Inner VLAN Tag				GEM	T-CONT
	Port #	Value	Value	TPID	Pbits	DEI	VID	TPID	Pbits	CFI or DEI	VID	Value	Value	Value	TPID	Pbits	DEI	VID	TPID	Pbits	CFI or DEI	VID	Port #	Number
A	1	MAC1	MAC2	n/a	n/a	n/a	n/a	0x8100	CPBIT1	n/a	CVID1	0x0800	x	x	n/a	n/a	n/a	n/a	0x8100	SPBIT1	x	SVID1	GEM1	TCONT1
B	1	MAC1	MAC2	n/a	n/a	n/a	n/a	0x8100	CPBIT3	n/a	CVID1	0x0800	x	x	n/a	n/a	n/a	n/a	0x8100	SPBIT2	x	SVID1	GEM2	TCONT2
C	1	MAC1	MAC2	n/a	n/a	n/a	n/a	0x8100	CPBIT4	n/a	CVID3	0x0800	x	x	n/a	n/a	n/a	n/a	0x8100	SPBIT3	x	SVID2	GEM3	TCONT3
D	1	MAC1	MAC2	n/a	n/a	n/a	n/a	0x8100	CPBIT6	n/a	CVID5	0x0800	x	x	n/a	n/a	n/a	n/a	0x8100	SPBIT4	x	SVID3	GEM4	TCONT4
E	1	MAC1	MAC2	n/a	n/a	n/a	n/a	0x8100	SPBIT3	n/a	SVID3	0x0800	x	x	n/a	n/a	n/a	n/a	0x8100	SPBIT3	x	SVID3	GEM3	TCONT3

Note: For the flow E, no specific rule is applied, only the upstream default rule is used.

- The traffic generator will be configured to transmit nine interleaved flows of Ethernet frames with the parameters in the next table in downstream. Also, GEM port/T-CONT mapping is shown.

Downstream Direction																							
Traffic Stream	S/R Interface													U Interface									
	MAC DA	MAC SA	Outer VLAN Tag				Inner VLAN Tag				Ethertype	IP DA	IP SA	GEM	Outer VLAN Tag				Inner VLAN Tag				UNI
	Value	Value	TPID	Pbits	DEI	VID	TPID	Pbits	CFI or DEI	VID	Value	Value	Value	Port #	TPID	Pbits	DEI	VID	TPID	Pbits	CFI or DEI	VID	Port #
A	MAC2	MAC1	n/a	n/a	n/a	n/a	0x8100	SPbit1	x	SVID1	0x0800	x	x	GEM1	n/a	n/a	n/a	n/a	0x8100	SPbit1	n/a	CVID1	1
B	MAC2	MAC1	n/a	n/a	n/a	n/a	0x8100	SPbit2	x	SVID1	0x0800	x	x	GEM2	n/a	n/a	n/a	n/a	0x8100	SPbit2	n/a	CVID1	1
C	MAC2	MAC1	n/a	n/a	n/a	n/a	0x8100	SPbit3	x	SVID2	0x0800	x	x	GEM3	n/a	n/a	n/a	n/a	0x8100	SPbit3	n/a	CVID3	1
D	MAC2	MAC1	n/a	n/a	n/a	n/a	0x8100	SPbit4	x	SVID3	0x0800	x	x	GEM4	n/a	n/a	n/a	n/a	0x8100	SPbit4	n/a	CVID5	1
E	MAC2	MAC1	n/a	n/a	n/a	n/a	0x8100	SPbit3	x	SVID3	0x0800	x	x	GEM3	n/a	n/a	n/a	n/a	0x8100	SPbit3	n/a	CVID5	1
F	MAC2	MAC1	n/a	n/a	n/a	n/a	0x8100	SPbit1	x	SVID4	0x0800	x	x	GEM1	n/a	n/a	n/a	n/a	0x8100	SPbit1	n/a	SVID4	1
G	MAC2	MAC1	n/a	n/a	n/a	n/a	0x8100	SPbit5	x	SVID4	0x0800	x	x	GEM4	n/a	n/a	n/a	n/a	0x8100	SPbit5	n/a	CVID5	1
H	MAC2	MAC1	n/a	n/a	n/a	n/a	0x8100	SPbit1	x	SVID2	0x0800	x	x	GEM1	n/a	n/a	n/a	n/a	0x8100	SPbit1	n/a	CVID3	1
I	MAC2	MAC1	n/a	n/a	n/a	n/a	0x8100	SPbit6	x	SVID5	0x0800	x	x	GEM2	n/a	n/a	n/a	n/a	0x8100	SPbit6	n/a	SVID5	1

Note: Flow F and I do not have corresponding specific upstream rules configured in OMCI.

- The OLT Emulator will be configured to send the sequence of OMCI messages required to provision the ONU under test
 - to support 4 traffic class, each one associated to a different P-bit value (i.e., P-bit mapping)
 - with 4 GEM ports and 4 downstream queues, each pair of GEM port-downstream queue assigned to one traffic class

Test Procedure

- Select distinct random values for CVID1 through CVID5 and SVID1 through SVID5 between 1 and 4094.

2. Select distinct random values for CPbit1 through CPbit6 and random distinct values for SPbit1 through SPbit6.
3. Select distinct random values for unicast MAC addresses MAC1 through MAC2
4. Cause the OLT Emulator to send the configured OMCI message sequence to provision the ONU.
5. Enable any frame capture mechanism on the OLT Emulator and the Ethernet traffic generator
6. Cause the OLT Emulator and Ethernet traffic generator to transmit the frames defined above
7. Verify that VID and P-bit values are correctly mapping into the right GEM ports and T-CONTs at the S/R-interface
8. Verify that VID and P-bit values are correctly translating into the right VID and P-bit at the S/R interface
9. In downstream direction, verify that VID values are correctly translating into the right VID at the U-interface
10. In downstream direction, verify that P-bit values are still the same at the U-interface as at the S/R interface
11. Verify that flow F and I are forwarded at the U interface in downstream direction without any frames modification.
12. Verify that flows E, G and H are forwarded at the U interface with the VID translation define in downstream direction table

OMCI Procedure Details

Refer to clause 4.3.

Pass/Fail Criteria

The test passes if the following are true, otherwise the test fails:

1. All OMCI commands have Success responses at step 4
2. At step 7, for each flow in the upstream direction, the resulting GEM port/T-CONT match the specifications detailed in the traffic table defined in configuration step 3
3. At step 8, for each flow in upstream direction, VID and P-bit values are correctly translating into the right VID and P-bit at the S/R interface, as defined in the traffic table from configuration step 3.
4. At step 9, for each flow in downstream direction, VID and P-bit values are correctly translating into the right VID and P-bit at the U interface, as defined in the traffic table from configuration step 4.
5. For each flow in downstream direction, P-bit values are still the same at the U-interface as at the S/R interface at step 10
6. The flow F and I in downstream is forwarded at the U-interface at step 11
7. The flow E, G and H in downstream is forwarded at the U-interface at step 12, with the correct VID defined in downstream direction table and the P-bit are still the same

Remarks

- None.

6.1.34 Downstream Translation for Code Point 4

Test Name

Downstream Translation for Code Point 4

Test Definition Number

ONU.6.1.34

Reference Document

BBF TR-280 [23]

ITU-T G.988 [6][7][8]

Test Type

Conformance

Test Requirement Type

Mandatory

Unit Under Test

ONU

Requirement Description

BBF TR-280

- [R-61] The ONU MUST support all actual code points (0 to 8) for the downstream mode attribute of the Extended VLAN tagging operation configuration data ME [ITU-T G.988]

Test Objective

Verify that the ONU is able to perform downstream translation for the code point 4 (Filter on p-bit only. On a match, perform the inverse p-bit operation only; pass the VID through. If no match is found, forward the frame unmodified).

Test Configuration

Note: Traffic flows definitions and names are consistent across tests 6.1.30 to 6.1.38 ("*downstream translation for Code Point x*"). In a given test case, some flows may be omitted and VID and P-bit values may not use the full declared range.

1. OLT Emulator and ONU under test are powered and connected to ODN
2. ONU activation and OMCC establishment processes have been successfully completed.

- The traffic generator will be configured to transmit five interleaved flows of Ethernet frames with the parameters in the next table in upstream. Also, GEM port/T-CONT mapping is shown.

Upstream Direction																								
Traffic Stream	U Interface													R/S Interface										
	UNI	MAC DA	MAC SA	Outer VLAN Tag				Inner VLAN Tag				Ethertype	IP DA	IP SA	Outer VLAN Tag				Inner VLAN Tag				GEM	T-CONT
	Port #	Value	Value	TPID	Pbits	DEI	VID	TPID	Pbits	CFI or DEI	VID	Value	Value	Value	TPID	Pbits	DEI	VID	TPID	Pbits	CFI or DEI	VID	Port #	Number
A	1	MAC1	MAC2	n/a	n/a	n/a	n/a	0x8100	CPbit1	n/a	CVID1	0x0800	x	x	n/a	n/a	n/a	n/a	0x8100	SPbit1	x	SVID1	GEM1	TCONT1
B	1	MAC1	MAC2	n/a	n/a	n/a	n/a	0x8100	CPbit3	n/a	CVID1	0x0800	x	x	n/a	n/a	n/a	n/a	0x8100	SPbit2	x	SVID1	GEM2	TCONT2
C	1	MAC1	MAC2	n/a	n/a	n/a	n/a	0x8100	CPbit4	n/a	CVID3	0x0800	x	x	n/a	n/a	n/a	n/a	0x8100	SPbit3	x	SVID2	GEM3	TCONT3
D	1	MAC1	MAC2	n/a	n/a	n/a	n/a	0x8100	CPbit6	n/a	CVID5	0x0800	x	x	n/a	n/a	n/a	n/a	0x8100	SPbit4	x	SVID3	GEM4	TCONT4
E	1	MAC1	MAC2	n/a	n/a	n/a	n/a	0x8100	SPbit3	n/a	SVID3	0x0800	x	x	n/a	n/a	n/a	n/a	0x8100	SPbit3	x	SVID3	GEM3	TCONT3

Note: For the flow E, no specific rule is applied, only the upstream default rule is used.

- The traffic generator will be configured to transmit nine interleaved flows of Ethernet frames with the parameters in the next table in downstream. Also, GEM port/T-CONT mapping is shown.

Downstream Direction																							
Traffic Stream	S/R Interface													U Interface									
	MAC DA	MAC SA	Outer VLAN Tag				Inner VLAN Tag				Ethertype	IP DA	IP SA	GEM	Outer VLAN Tag				Inner VLAN Tag				UNI
	Value	Value	TPID	Pbits	DEI	VID	TPID	Pbits	CFI or DEI	VID	Value	Value	Value	Port #	TPID	Pbits	DEI	VID	TPID	Pbits	CFI or DEI	VID	Port #
A	MAC2	MAC1	n/a	n/a	n/a	n/a	0x8100	SPbit1	x	SVID1	0x0800	x	x	GEM1	n/a	n/a	n/a	n/a	0x8100	CPbit1	n/a	SVID1	1
B	MAC2	MAC1	n/a	n/a	n/a	n/a	0x8100	SPbit2	x	SVID1	0x0800	x	x	GEM2	n/a	n/a	n/a	n/a	0x8100	CPbit3	n/a	SVID1	1
C	MAC2	MAC1	n/a	n/a	n/a	n/a	0x8100	SPbit3	x	SVID2	0x0800	x	x	GEM3	n/a	n/a	n/a	n/a	0x8100	CPbit4	n/a	SVID2	1
D	MAC2	MAC1	n/a	n/a	n/a	n/a	0x8100	SPbit4	x	SVID3	0x0800	x	x	GEM4	n/a	n/a	n/a	n/a	0x8100	CPbit6	n/a	SVID3	1
E	MAC2	MAC1	n/a	n/a	n/a	n/a	0x8100	SPbit3	x	SVID3	0x0800	x	x	GEM3	n/a	n/a	n/a	n/a	0x8100	CPbit4	n/a	SVID3	1
F	MAC2	MAC1	n/a	n/a	n/a	n/a	0x8100	SPbit1	x	SVID4	0x0800	x	x	GEM1	n/a	n/a	n/a	n/a	0x8100	CPbit1	n/a	SVID4	1
G	MAC2	MAC1	n/a	n/a	n/a	n/a	0x8100	SPbit5	x	SVID4	0x0800	x	x	GEM4	n/a	n/a	n/a	n/a	0x8100	SPbit5	n/a	SVID4	1
H	MAC2	MAC1	n/a	n/a	n/a	n/a	0x8100	SPbit1	x	SVID2	0x0800	x	x	GEM1	n/a	n/a	n/a	n/a	0x8100	CPbit1	n/a	SVID2	1
I	MAC2	MAC1	n/a	n/a	n/a	n/a	0x8100	SPbit6	x	SVID5	0x0800	x	x	GEM2	n/a	n/a	n/a	n/a	0x8100	SPbit6	n/a	SVID5	1

Note: Flow G and I do not have corresponding specific upstream rules configured in OMCI.

- The OLT Emulator will be configured to send the sequence of OMCI messages required to provision the ONU under test
 - to support 4 traffic class, each one associated to a different P-bit value (i.e., P-bit mapping)
 - with 4 GEM ports and 4 downstream queues, each pair of GEM port-downstream queue assigned to one traffic class

Test Procedure

- Select distinct random values for CVID1 through CVID5 and SVID1 through SVID6 between 1 and 4094.

2. Select distinct random values for CPbit1 through CPbit6 and random distinct values for SPbit1 through SPbit6.
3. Select distinct random values for unicast MAC addresses MAC1 through MAC2
4. Cause the OLT Emulator to send the configured OMCI message sequence to provision the ONU.
5. Enable any frame capture mechanism on the OLT Emulator and the Ethernet traffic generator
6. Cause the OLT Emulator and Ethernet traffic generator to transmit the frames defined above
7. Verify that VID and P-bit values are correctly mapping into the right GEM ports and T-CONTs at the S/R-interface
8. Verify that VID and P-bit values are correctly translating into the right VID and P-bit at the S/R interface
9. In downstream direction, verify that P-bit values are correctly translating into the right P-bit at the U-interface
10. In downstream direction, verify that VID values are still the same at the U-interface as at the S/R interface
11. Verify that flow G and I are forwarded at the U interface in downstream direction without any frames modification.
12. Verify that flows E, F and H are forwarded at the U interface with the P-bit translation define in downstream direction table

OMCI Procedure Details

Refer to clause 4.3.

Pass/Fail Criteria

The test passes if the following are true, otherwise the test fails:

1. All OMCI commands have Success responses at step 4
2. At step 7, for each flow in the upstream direction, the resulting GEM port/T-CONT match the specifications detailed in the traffic table defined in configuration step 3
3. At step 8, for each flow in upstream direction, VID and P-bit values are correctly translating into the right VID and P-bit at the S/R interface, as defined in the traffic table from configuration step 3.
4. At step 9, for each flow in downstream direction, VID and P-bit values are correctly translating into the right VID and P-bit at the U interface, as defined in the traffic table from configuration step 4.
5. For each flow in downstream direction, VID values are still the same at the U-interface as at the S/R interface at step 10
6. The flow G and I in downstream are forwarded at the U-interface at step 11
7. The flow E, F and H in downstream is forwarded at the U-interface at step 12, with the correct P-bit defined in downstream direction table and the VID are still the same

Remarks

- None.

6.1.35 Downstream Translation for Code Point 5

Test Name

Downstream Translation for Code Point 5

Test Definition Number

ONU.6.1.35

Reference Document

BBF TR-280 [23]

ITU-T G.988 [6][7][8]

Test Type

Conformance

Test Requirement Type

Mandatory

Unit Under Test

ONU

Requirement Description**BBF TR-280**

- **[R-61]** The ONU MUST support all actual code points (0 to 8) for the downstream mode attribute of the Extended VLAN tagging operation configuration data ME [ITU-T G.988]

Test Objective

Verify that the ONU is able to perform downstream translation for the code point 5 (Filter on VID and p-bit value. On a match, perform the inverse operation on both the VID and p-bit value. If no match is found, discard the frame.).

Test Configuration

Note: Traffic flows definitions and names are consistent across tests 6.1.30 to 6.1.38 ("*downstream translation for Code Point x*"). In a given test case, some flows may be omitted and VID and P-bit values may not use the full declared range.

1. OLT Emulator and ONU under test are powered and connected to ODN
2. ONU activation and OMCC establishment processes have been successfully completed.

- The traffic generator will be configured to transmit five interleaved flows of Ethernet frames with the parameters in the next table in upstream. Also, GEM port/T-CONT mapping is shown.

Upstream Direction																								
Traffic Stream	U Interface													R/S Interface										
	UNI	MAC DA	MAC SA	Outer VLAN Tag				Inner VLAN Tag				Ethertype	IP DA	IP SA	Outer VLAN Tag				Inner VLAN Tag				GEM	T-CONT
	Port #	Value	Value	TPID	Pbits	DEI	VID	TPID	Pbits	CFI or DEI	VID	Value	Value	Value	TPID	Pbits	DEI	VID	TPID	Pbits	CFI or DEI	VID	Port #	Number
A	1	MAC1	MAC2	n/a	n/a	n/a	n/a	0x8100	CPBIT1	n/a	CVID1	0x0800	x	x	n/a	n/a	n/a	n/a	0x8100	SPBIT1	x	SVID1	GEM1	TCONT1
B	1	MAC1	MAC2	n/a	n/a	n/a	n/a	0x8100	CPBIT3	n/a	CVID2	0x0800	x	x	n/a	n/a	n/a	n/a	0x8100	SPBIT2	x	SVID1	GEM2	TCONT2
C	1	MAC1	MAC2	n/a	n/a	n/a	n/a	0x8100	CPBIT4	n/a	CVID3	0x0800	x	x	n/a	n/a	n/a	n/a	0x8100	SPBIT3	x	SVID2	GEM3	TCONT3
D	1	MAC1	MAC2	n/a	n/a	n/a	n/a	0x8100	CPBIT6	n/a	CVID5	0x0800	x	x	n/a	n/a	n/a	n/a	0x8100	SPBIT4	x	SVID3	GEM4	TCONT4
E	1	MAC1	MAC2	n/a	n/a	n/a	n/a	0x8100	SPBIT3	n/a	SVID3	0x0800	x	x	n/a	n/a	n/a	n/a	0x8100	SPBIT3	x	SVID3	GEM3	TCONT3

Note: For the flow E, no specific rule is applied, only the upstream default rule is used.

- The traffic generator will be configured to transmit nine interleaved flows of Ethernet frames with the parameters in the next table in downstream. Also, GEM port/T-CONT mapping is shown.

Downstream Direction																								
Traffic Stream	S/R Interface														U Interface									
	MAC DA	MAC SA	Outer VLAN Tag				Inner VLAN Tag				Ethertype	IP DA	IP SA	GEM	Outer VLAN Tag				Inner VLAN Tag				UNI	
	Value	Value	TPID	Pbits	DEI	VID	TPID	Pbits	CFI or DEI	VID	Value	Value	Value	Port #	TPID	Pbits	DEI	VID	TPID	Pbits	CFI or DEI	VID	Port #	
A	MAC2	MAC1	n/a	n/a	n/a	n/a	0x8100	SPbit1	x	SVID1	0x0800	x	x	GEM1	n/a	n/a	n/a	n/a	0x8100	CPbit1	n/a	CVID1	1	
B	MAC2	MAC1	n/a	n/a	n/a	n/a	0x8100	SPbit2	x	SVID1	0x0800	x	x	GEM2	n/a	n/a	n/a	n/a	0x8100	CPbit3	n/a	CVID2	1	
C	MAC2	MAC1	n/a	n/a	n/a	n/a	0x8100	SPbit3	x	SVID2	0x0800	x	x	GEM3	n/a	n/a	n/a	n/a	0x8100	CPbit4	n/a	CVID3	1	
D	MAC2	MAC1	n/a	n/a	n/a	n/a	0x8100	SPbit4	x	SVID3	0x0800	x	x	GEM4	n/a	n/a	n/a	n/a	0x8100	CPbit6	n/a	CVID5	1	
E	MAC2	MAC1	n/a	n/a	n/a	n/a	0x8100	SPbit3	x	SVID3	0x0800	x	x	GEM3	n/a	n/a	n/a	n/a	n/a	n/a	n/a	n/a	n/a	
F	MAC2	MAC1	n/a	n/a	n/a	n/a	0x8100	SPbit1	x	SVID4	0x0800	x	x	GEM1	n/a	n/a	n/a	n/a	n/a	n/a	n/a	n/a	n/a	
G	MAC2	MAC1	n/a	n/a	n/a	n/a	0x8100	SPbit5	x	SVID4	0x0800	x	x	GEM4	n/a	n/a	n/a	n/a	n/a	n/a	n/a	n/a	n/a	
H	MAC2	MAC1	n/a	n/a	n/a	n/a	0x8100	SPbit1	x	SVID2	0x0800	x	x	GEM1	n/a	n/a	n/a	n/a	n/a	n/a	n/a	n/a	n/a	
I	MAC2	MAC1	n/a	n/a	n/a	n/a	0x8100	SPbit6	x	SVID5	0x0800	x	x	GEM2	n/a	n/a	n/a	n/a	n/a	n/a	n/a	n/a	n/a	

Note: Flow E, F, G, H, and I do not have corresponding specific upstream rules configured in OMCI.

- The OLT Emulator will be configured to send the sequence of OMCI messages required to provision the ONU under test
 - to support 4 traffic class, each one associated to a different P-bit value (i.e., P-bit mapping)
 - with 4 GEM ports and 4 downstream queues, each pair of GEM port-downstream queue assigned to one traffic class

Test Procedure

- Select distinct random values for CVID1 through CVID5 and SVID1 through SVID5 between 1 and 4094.

2. Select distinct random values for CPbit1 through CPbit6 and random distinct values for SPbit1 through SPbit6.
3. Select distinct random values for unicast MAC addresses MAC1 through MAC2
4. Cause the OLT Emulator to send the configured OMCI message sequence to provision the ONU.
5. Enable any frame capture mechanism on the OLT Emulator and the Ethernet traffic generator
6. Cause the OLT Emulator and Ethernet traffic generator to transmit the frames defined above
7. Verify that VID and P-bit values are correctly mapping into the right GEM ports and T-CONTs at the S/R-interface
8. Verify that VID and P-bit values are correctly translating into the right VID and P-bit at the S/R interface
9. Verify that VID and P-bit values are correctly translating into the right VID and P-bit at the U-interface
10. Verify that flow E, F, G, H and I are discarded at the U interface in downstream direction.

OMCI Procedure Details

Refer to clause 4.3.

Pass/Fail Criteria

The test passes if the following are true, otherwise the test fails:

1. All OMCI commands have Success responses at step 4
2. At step 7, for each flow in the upstream direction, the resulting GEM port/T-CONT match the specifications detailed in the traffic table defined in configuration step 3
3. At step 8, for each flow in upstream direction, VID and P-bit values are correctly translating into the right VID and P-bit at the S/R interface, as defined in the traffic table from configuration step 3.
4. At step 9, for each flow in downstream direction, VID and P-bit values are correctly translating into the right VID and P-bit at the U interface, as defined in the traffic table from configuration step 4.
5. The flow E, F, G, H and I in downstream are discarded at the U interface in downstream direction at step 10

Remarks

- None.

6.1.36 Downstream Translation for Code Point 6

Test Name

Downstream Translation for Code Point 6

Test Definition Number

ONU.6.1.36

Reference Document

BBF TR-280 [23]

ITU-T G.988 [6][7][8]

Test Type

Conformance

Test Requirement Type

Mandatory

Unit Under Test

ONU

Requirement Description**BBF TR-280**

- **[R-61]** The ONU MUST support all actual code points (0 to 8) for the downstream mode attribute of the Extended VLAN tagging operation configuration data ME [ITU-T G.988]

Test Objective

Verify that the ONU is able to perform downstream translation for the code point 6 (Filter on VID. On a match, perform the inverse operation on the VID only; pass the p bits through. If no match is found, discard the frame).

Test Configuration

Note: Traffic flows definitions and names are consistent across tests 6.1.30 to 6.1.38 ("*downstream translation for Code Point x*"). In a given test case, some flows may be omitted and VID and P-bit values may not use the full declared range.

1. OLT Emulator and ONU under test are powered and connected to ODN
2. ONU activation and OMCC establishment processes have been successfully completed.

- The traffic generator will be configured to transmit five interleaved flows of Ethernet frames with the parameters in the next table in upstream. Also, GEM port/T-CONT mapping is shown.

Upstream Direction																								
Traffic Stream	U Interface													R/S Interface										
	UNI	MAC DA	MAC SA	Outer VLAN Tag				Inner VLAN Tag				Ethertype	IP DA	IP SA	Outer VLAN Tag				Inner VLAN Tag				GEM	T-CONT
	Port #	Value	Value	TPID	Pbits	DEI	VID	TPID	Pbits	CFI or DEI	VID	Value	Value	Value	TPID	Pbits	DEI	VID	TPID	Pbits	CFI or DEI	VID	Port #	Number
A	1	MAC1	MAC2	n/a	n/a	n/a	n/a	0x8100	CPBIT1	n/a	CVID1	0x0800	x	x	n/a	n/a	n/a	n/a	0x8100	SPBIT1	x	SVID1	GEM1	TCONT1
B	1	MAC1	MAC2	n/a	n/a	n/a	n/a	0x8100	CPBIT3	n/a	CVID1	0x0800	x	x	n/a	n/a	n/a	n/a	0x8100	SPBIT2	x	SVID1	GEM2	TCONT2
C	1	MAC1	MAC2	n/a	n/a	n/a	n/a	0x8100	CPBIT4	n/a	CVID3	0x0800	x	x	n/a	n/a	n/a	n/a	0x8100	SPBIT3	x	SVID2	GEM3	TCONT3
D	1	MAC1	MAC2	n/a	n/a	n/a	n/a	0x8100	CPBIT6	n/a	CVID5	0x0800	x	x	n/a	n/a	n/a	n/a	0x8100	SPBIT4	x	SVID3	GEM4	TCONT4
E	1	MAC1	MAC2	n/a	n/a	n/a	n/a	0x8100	SPBIT3	n/a	SVID3	0x0800	x	x	n/a	n/a	n/a	n/a	0x8100	SPBIT3	x	SVID3	GEM3	TCONT3

Note: For the flow E, no specific rule is applied, only the upstream default rule is used.

- The traffic generator will be configured to transmit nine interleaved flows of Ethernet frames with the parameters in the next table in downstream. Also, GEM port/T-CONT mapping is shown.

Downstream Direction																								
Traffic Stream	S/R Interface														U Interface									
	MAC DA	MAC SA	Outer VLAN Tag				Inner VLAN Tag				Ethertype	IP DA	IP SA	GEM	Outer VLAN Tag				Inner VLAN Tag				UNI	
	Value	Value	TPID	Pbits	DEI	VID	TPID	Pbits	CFI or DEI	VID	Value	Value	Value	Port #	TPID	Pbits	DEI	VID	TPID	Pbits	CFI or DEI	VID	Port #	
A	MAC2	MAC1	n/a	n/a	n/a	n/a	0x8100	SPbit1	x	SVID1	0x0800	x	x	GEM1	n/a	n/a	n/a	n/a	0x8100	SPbit1	n/a	CVID1	1	
B	MAC2	MAC1	n/a	n/a	n/a	n/a	0x8100	SPbit2	x	SVID1	0x0800	x	x	GEM2	n/a	n/a	n/a	n/a	0x8100	SPbit2	n/a	CVID1	1	
C	MAC2	MAC1	n/a	n/a	n/a	n/a	0x8100	SPbit3	x	SVID2	0x0800	x	x	GEM3	n/a	n/a	n/a	n/a	0x8100	SPbit3	n/a	CVID3	1	
D	MAC2	MAC1	n/a	n/a	n/a	n/a	0x8100	SPbit4	x	SVID3	0x0800	x	x	GEM4	n/a	n/a	n/a	n/a	0x8100	SPbit4	n/a	CVID5	1	
E	MAC2	MAC1	n/a	n/a	n/a	n/a	0x8100	SPbit3	x	SVID3	0x0800	x	x	GEM3	n/a	n/a	n/a	n/a	0x8100	SPbit3	n/a	CVID5	1	
F	MAC2	MAC1	n/a	n/a	n/a	n/a	0x8100	SPbit1	x	SVID4	0x0800	x	x	GEM1	n/a	n/a	n/a	n/a	n/a	n/a	n/a	n/a	n/a	
G	MAC2	MAC1	n/a	n/a	n/a	n/a	0x8100	SPbit5	x	SVID3	0x0800	x	x	GEM4	n/a	n/a	n/a	n/a	0x8100	SPbit5	n/a	CVID5	1	
H	MAC2	MAC1	n/a	n/a	n/a	n/a	0x8100	SPbit1	x	SVID2	0x0800	x	x	GEM1	n/a	n/a	n/a	n/a	0x8100	SPbit1	n/a	CVID3	1	
I	MAC2	MAC1	n/a	n/a	n/a	n/a	0x8100	SPbit6	x	SVID5	0x0800	x	x	GEM2	n/a	n/a	n/a	n/a	n/a	n/a	n/a	n/a	n/a	

Note: Flow E, F and I do not have corresponding specific upstream rules configured in OMCI.

- The OLT Emulator will be configured to send the sequence of OMCI messages required to provision the ONU under test
 - to support 4 traffic class, each one associated to a different P-bit value (i.e., P-bit mapping)
 - with 4 GEM ports and 4 downstream queues, each pair of GEM port-downstream queue assigned to one traffic class

Test Procedure

- Select distinct random values for CVID1 through CVID5 and SVID1 through SVID5 between 1 and 4094.

2. Select distinct random values for CPbit1 through CPbit6 and random distinct values for SPbit1 through SPbit6.
3. Select distinct random values for unicast MAC addresses MAC1 through MAC2
4. Cause the OLT Emulator to send the configured OMCI message sequence to provision the ONU.
5. Enable any frame capture mechanism on the OLT Emulator and the Ethernet traffic generator
6. Cause the OLT Emulator and Ethernet traffic generator to transmit the frames defined above
7. Verify that VID and P-bit values are correctly mapping into the right GEM ports and T-CONTs at the S/R-interface
8. Verify that VID and P-bit values are correctly translating into the right VID and P-bit at the S/R interface
9. In downstream direction, verify that VID values are correctly translating into the right VID at the U-interface
10. In downstream direction, verify that P-bit values are still the same at the U-interface as at the S/R interface
11. Verify that flow F and I are discarded at the U interface in downstream direction
12. Verify that flows E, G, and H are forwarded at the U interface with the VID translation define in downstream direction table

OMCI Procedure Details

Refer to clause 4.3.

Pass/Fail Criteria

The test passes if the following are true, otherwise the test fails:

1. All OMCI commands have Success responses at step 4
2. At step 7, for each flow in the upstream direction, the resulting GEM port/T-CONT match the specifications detailed in the traffic table defined in configuration step 3
3. At step 8, for each flow in upstream direction, VID and P-bit values are correctly translating into the right VID and P-bit at the S/R interface, as defined in the traffic table from configuration step 3.
4. At step 9, for each flow in downstream direction, VID and P-bit values are correctly translating into the right VID and P-bit at the U interface, as defined in the traffic table from configuration step 4.
5. For each flow in downstream direction, P-bit values are still the same at the U-interface as at the S/R interface at step 10
6. The flow F and I in downstream are discarded at the U-interface at step 11
7. The flow E, G and H in downstream is forwarded at the U-interface at step 12, with the correct VID defined in downstream direction table and the P-bit is still the same

Remarks

- None.

6.1.37 Downstream Translation for Code Point 7

Test Name

Downstream Translation for Code Point 7

Test Definition Number

ONU.6.1.37

Reference Document

BBF TR-280 [23]

ITU-T G.988 [6][7][8]

Test Type

Conformance

Test Requirement Type

Mandatory

Unit Under Test

ONU

Requirement Description

BBF TR-280

- [R-61] The ONU MUST support all actual code points (0 to 8) for the downstream mode attribute of the Extended VLAN tagging operation configuration data ME [ITU-T G.988]

Test Objective

Verify that the ONU is able to perform downstream translation for the code point 7 (Filter on p-bit only. On a match, perform the inverse p-bit operation only; pass the VID through. If no match is found, discard the frame).

Test Configuration

Note: Traffic flows definitions and names are consistent across tests 6.1.30 to 6.1.38 ("*downstream translation for Code Point x*"). In a given test case, some flows may be omitted and VID and P-bit values may not use the full declared range.

1. OLT Emulator and ONU under test are powered and connected to ODN
2. ONU activation and OMCC establishment processes have been successfully completed.

- The traffic generator will be configured to transmit five interleaved flows of Ethernet frames with the parameters in the next table in upstream. Also, GEM port/T-CONT mapping is shown.

Upstream Direction																								
Traffic Stream	U Interface													R/S Interface										
	UNI	MAC DA	MAC SA	Outer VLAN Tag				Inner VLAN Tag				Ethertype	IP DA	IP SA	Outer VLAN Tag				Inner VLAN Tag				GEM	T-CONT
	Port #	Value	Value	TPID	Pbits	DEI	VID	TPID	Pbits	CFI or DEI	VID	Value	Value	Value	TPID	Pbits	DEI	VID	TPID	Pbits	CFI or DEI	VID	Port #	Number
A	1	MAC1	MAC2	n/a	n/a	n/a	n/a	0x8100	CPBIT1	n/a	CVID1	0x0800	x	x	n/a	n/a	n/a	n/a	0x8100	SPBIT1	x	SVID1	GEM1	TCONT1
B	1	MAC1	MAC2	n/a	n/a	n/a	n/a	0x8100	CPBIT3	n/a	CVID1	0x0800	x	x	n/a	n/a	n/a	n/a	0x8100	SPBIT2	x	SVID1	GEM2	TCONT2
C	1	MAC1	MAC2	n/a	n/a	n/a	n/a	0x8100	CPBIT4	n/a	CVID3	0x0800	x	x	n/a	n/a	n/a	n/a	0x8100	SPBIT3	x	SVID2	GEM3	TCONT3
D	1	MAC1	MAC2	n/a	n/a	n/a	n/a	0x8100	CPBIT6	n/a	CVID5	0x0800	x	x	n/a	n/a	n/a	n/a	0x8100	SPBIT4	x	SVID3	GEM4	TCONT4
E	1	MAC1	MAC2	n/a	n/a	n/a	n/a	0x8100	SPBIT3	n/a	SVID3	0x0800	x	x	n/a	n/a	n/a	n/a	0x8100	SPBIT3	x	SVID3	GEM3	TCONT3

Note: For the flow E, no specific rule is applied, only the upstream default rule is used.

- The traffic generator will be configured to transmit nine interleaved flows of Ethernet frames with the parameters in the next table in downstream. Also, GEM port/T-CONT mapping is shown.

Downstream Direction																								
Traffic Stream	S/R Interface														U Interface									
	MAC DA	MAC SA	Outer VLAN Tag				Inner VLAN Tag				Ethertype	IP DA	IP SA	GEM	Outer VLAN Tag				Inner VLAN Tag				UNI	
	Value	Value	TPID	Pbits	DEI	VID	TPID	Pbits	CFI or DEI	VID	Value	Value	Value	Port #	TPID	Pbits	DEI	VID	TPID	Pbits	CFI or DEI	VID	Port #	
A	MAC2	MAC1	n/a	n/a	n/a	n/a	0x8100	SPbit1	x	SVID1	0x0800	x	x	GEM1	n/a	n/a	n/a	n/a	0x8100	CPbit1	n/a	SVID1	1	
B	MAC2	MAC1	n/a	n/a	n/a	n/a	0x8100	SPbit2	x	SVID1	0x0800	x	x	GEM2	n/a	n/a	n/a	n/a	0x8100	CPbit3	n/a	SVID1	1	
C	MAC2	MAC1	n/a	n/a	n/a	n/a	0x8100	SPbit3	x	SVID2	0x0800	x	x	GEM3	n/a	n/a	n/a	n/a	0x8100	CPbit4	n/a	SVID2	1	
D	MAC2	MAC1	n/a	n/a	n/a	n/a	0x8100	SPbit4	x	SVID3	0x0800	x	x	GEM4	n/a	n/a	n/a	n/a	0x8100	CPbit6	n/a	SVID3	1	
E	MAC2	MAC1	n/a	n/a	n/a	n/a	0x8100	SPbit3	x	SVID3	0x0800	x	x	GEM3	n/a	n/a	n/a	n/a	0x8100	CPbit4	n/a	SVID3	1	
F	MAC2	MAC1	n/a	n/a	n/a	n/a	0x8100	SPbit1	x	SVID4	0x0800	x	x	GEM1	n/a	n/a	n/a	n/a	0x8100	CPbit1	n/a	SVID4	1	
G	MAC2	MAC1	n/a	n/a	n/a	n/a	0x8100	SPbit5	x	SVID4	0x0800	x	x	GEM4	n/a	n/a	n/a	n/a	n/a	n/a	n/a	n/a	n/a	
H	MAC2	MAC1	n/a	n/a	n/a	n/a	0x8100	SPbit1	x	SVID2	0x0800	x	x	GEM1	n/a	n/a	n/a	n/a	0x8100	CPbit1	n/a	SVID2	1	
I	MAC2	MAC1	n/a	n/a	n/a	n/a	0x8100	SPbit6	x	SVID5	0x0800	x	x	GEM2	n/a	n/a	n/a	n/a	n/a	n/a	n/a	n/a	n/a	

Note: Flow G and I do not have corresponding specific upstream rules configured in OMCI.

- The OLT Emulator will be configured to send the sequence of OMCI messages required to provision the ONU under test
 - to support 4 traffic class, each one associated to a different P-bit value (i.e., P-bit mapping)
 - with 4 GEM ports and 4 downstream queues, each pair of GEM port-downstream queue assigned to one traffic class

Test Procedure

- Select distinct random values for CVID1 through CVID5 and SVID1 through SVID6 between 1 and 4094.

2. Select distinct random values for CPbit1 through CPbit6 and random distinct values for SPbit1 through SPbit6.
3. Select distinct random values for unicast MAC addresses MAC1 through MAC2
4. Cause the OLT Emulator to send the configured OMCI message sequence to provision the ONU.
5. Enable any frame capture mechanism on the OLT Emulator and the Ethernet traffic generator
6. Cause the OLT Emulator and Ethernet traffic generator to transmit the frames defined above
7. Verify that VID and P-bit values are correctly mapping into the right GEM ports and T-CONTs at the S/R-interface
8. Verify that VID and P-bit values are correctly translating into the right VID and P-bit at the S/R interface
9. In downstream direction, verify that P-bit values are correctly translating into the right P-bit at the U-interface
10. In downstream direction, verify that VID values are still the same at the U-interface as at the S/R interface
11. Verify that flow G and I are discarded at the U interface in downstream direction without any frames modification.
12. Verify that flows E, F and H are forwarded at the U interface with the P-bit translation define in downstream direction table

OMCI Procedure Details

Refer to clause 4.3.

Pass/Fail Criteria

The test passes if the following are true, otherwise the test fails:

1. All OMCI commands have Success responses at step 4
2. At step 7, for each flow in the upstream direction, the resulting GEM port/T-CONT match the specifications detailed in the traffic table defined in configuration step 3
3. At step 8, for each flow in upstream direction, VID and P-bit values are correctly translating into the right VID and P-bit at the S/R interface, as defined in the traffic table from configuration step 3.
4. At step 9, for each flow in downstream direction, VID and P-bit values are correctly translating into the right VID and P-bit at the U interface, as defined in the traffic table from configuration step 4.
5. For each flow in downstream direction, VID values are still the same at the U-interface as at the S/R interface at step 10
6. The flow G and I in downstream are discarded at the U-interface at step 11
7. The flow E, F and H in downstream is forwarded at the U-interface at step 12, with the correct P-bit defined in downstream direction table and the VID are still the same

Remarks

- None.

6.1.38 Downstream Translation for Code Point 8

Test Name

Downstream Translation for Code Point 8

Test Definition Number

ONU.6.1.38

Reference Document

BBF TR-280 [23]

ITU-T G.988 [6][7][8]

Test Type

Conformance

Test Requirement Type

Mandatory

Unit Under Test

ONU

Requirement Description

BBF TR-280

- **[R-61]** The ONU MUST support all actual code points (0 to 8) for the downstream mode attribute of the Extended VLAN tagging operation configuration data ME [ITU-T G.988]

Test Objective

Verify that the ONU is able to perform downstream translation for the code point 8 (Regardless of the filter rules, discard all downstream traffic).

Test Configuration

Note: Traffic flows definitions and names are consistent across tests 6.1.30 to 6.1.38 ("*downstream translation for Code Point x*"). In a given test case, some flows may be omitted and VID and P-bit values may not use the full declared range.

1. OLT Emulator and ONU under test are powered and connected to ODN
2. ONU activation and OMCC establishment processes have been successfully completed.

- The traffic generator will be configured to transmit five interleaved flows of Ethernet frames with the parameters in the next table in upstream. Also, GEM port/T-CONT mapping is shown.

Upstream Direction																								
Traffic Stream	U Interface													R/S Interface										
	UNI	MAC DA	MAC SA	Outer VLAN Tag				Inner VLAN Tag				Ethertype	IP DA	IP SA	Outer VLAN Tag				Inner VLAN Tag				GEM	T-CONT
	Port #	Value	Value	TPID	Pbits	DEI	VID	TPID	Pbits	CFI or DEI	VID	Value	Value	Value	TPID	Pbits	DEI	VID	TPID	Pbits	CFI or DEI	VID	Port #	Number
A	1	MAC1	MAC2	n/a	n/a	n/a	n/a	0x8100	CPBIT1	n/a	CVID1	0x0800	x	x	n/a	n/a	n/a	n/a	0x8100	SPBIT1	x	SVID1	GEM1	TCONT1
B	1	MAC1	MAC2	n/a	n/a	n/a	n/a	0x8100	CPBIT3	n/a	CVID1	0x0800	x	x	n/a	n/a	n/a	n/a	0x8100	SPBIT2	x	SVID1	GEM2	TCONT2
C	1	MAC1	MAC2	n/a	n/a	n/a	n/a	0x8100	CPBIT4	n/a	CVID3	0x0800	x	x	n/a	n/a	n/a	n/a	0x8100	SPBIT3	x	SVID2	GEM3	TCONT3
D	1	MAC1	MAC2	n/a	n/a	n/a	n/a	0x8100	CPBIT6	n/a	CVID5	0x0800	x	x	n/a	n/a	n/a	n/a	0x8100	SPBIT4	x	SVID3	GEM4	TCONT4
E	1	MAC1	MAC2	n/a	n/a	n/a	n/a	0x8100	SPBIT3	n/a	SVID3	0x0800	x	x	n/a	n/a	n/a	n/a	0x8100	SPBIT3	x	SVID3	GEM3	TCONT3

Note: For the flow E, no specific rule is applied, only the upstream default rule is used.

- The traffic generator will be configured to transmit nine interleaved flows of Ethernet frames with the parameters in the next table in downstream. Also, GEM port/T-CONT mapping is shown.

Downstream Direction																							
Traffic Stream	S/R Interface														U Interface								
	MAC DA	MAC SA	Outer VLAN Tag				Inner VLAN Tag				Ethertype	IP DA	IP SA	GEM	Outer VLAN Tag				Inner VLAN Tag				UNI
	Value	Value	TPID	Pbits	DEI	VID	TPID	Pbits	CFI or DEI	VID	Value	Value	Value	Port #	TPID	Pbits	DEI	VID	TPID	Pbits	CFI or DEI	VID	Port #
A	MAC2	MAC1	n/a	n/a	n/a	n/a	0x8100	SPBIT1	x	SVID1	0x0800	x	x	GEM1	n/a	n/a	n/a	n/a	n/a	n/a	n/a	n/a	n/a
B	MAC2	MAC1	n/a	n/a	n/a	n/a	0x8100	SPBIT2	x	SVID1	0x0800	x	x	GEM2	n/a	n/a	n/a	n/a	n/a	n/a	n/a	n/a	n/a
C	MAC2	MAC1	n/a	n/a	n/a	n/a	0x8100	SPBIT3	x	SVID2	0x0800	x	x	GEM3	n/a	n/a	n/a	n/a	n/a	n/a	n/a	n/a	n/a
D	MAC2	MAC1	n/a	n/a	n/a	n/a	0x8100	SPBIT4	x	SVID3	0x0800	x	x	GEM4	n/a	n/a	n/a	n/a	n/a	n/a	n/a	n/a	n/a
E	MAC2	MAC1	n/a	n/a	n/a	n/a	0x8100	SPBIT3	x	SVID3	0x0800	x	x	GEM3	n/a	n/a	n/a	n/a	n/a	n/a	n/a	n/a	n/a
F	MAC2	MAC1	n/a	n/a	n/a	n/a	0x8100	SPBIT1	x	SVID4	0x0800	x	x	GEM1	n/a	n/a	n/a	n/a	n/a	n/a	n/a	n/a	n/a
G	MAC2	MAC1	n/a	n/a	n/a	n/a	0x8100	SPBIT5	x	SVID4	0x0800	x	x	GEM4	n/a	n/a	n/a	n/a	n/a	n/a	n/a	n/a	n/a
H	MAC2	MAC1	n/a	n/a	n/a	n/a	0x8100	SPBIT1	x	SVID2	0x0800	x	x	GEM1	n/a	n/a	n/a	n/a	n/a	n/a	n/a	n/a	n/a
I	MAC2	MAC1	n/a	n/a	n/a	n/a	0x8100	SPBIT6	x	SVID5	0x0800	x	x	GEM2	n/a	n/a	n/a	n/a	n/a	n/a	n/a	n/a	n/a

- The OLT Emulator will be configured to send the sequence of OMCI messages required to provision the ONU under test
 - to support 4 traffic class, each one associated to a different P-bit value (i.e., P-bit mapping)
 - with 4 GEM ports and 4 downstream queues, each pair of GEM port-downstream queue assigned to one traffic class

Test Procedure

- Select distinct random values for CVID1 through CVID5 and SVID1 through SVID5 between 1 and 4094.
- Select distinct random values for CPbit1 through CPbit6 and random distinct values for SPbit1 through SPbit6.
- Select distinct random values for unicast MAC addresses MAC1 through MAC2

4. Cause the OLT Emulator to send the configured OMCI message sequence to provision the ONU.
5. Enable any frame capture mechanism on the OLT Emulator and the Ethernet traffic generator
6. Cause the OLT Emulator and Ethernet traffic generator to transmit the frames defined above
7. Verify that VID and P-bit values are correctly mapping into the right GEM ports and T-CONTs at the S/R-interface
8. Verify that VID and P-bit values are correctly translating into the right VID and P-bit at the S/R interface
9. Verify that flow A to I are discarded at the U interface in downstream direction without any frames modification.

OMCI Procedure Details

Refer to clause 4.3.

Pass/Fail Criteria

The test passes if the following are true, otherwise the test fails:

1. All OMCI commands have Success responses at step 4.
2. At step 7, for each flow in the upstream direction, the resulting GEM port/T-CONT match the specifications detailed in the traffic table defined in configuration step 3.
3. At step 8, for each flow in upstream direction, VID and P-bit values are correctly translating into the right VID and P-bit at the S/R interface, as defined in the traffic table from configuration step 3.
4. At step 9, for each flow in downstream direction, VID and P-bit values are correctly translating into the right VID and P-bit at the U interface, as defined in the traffic table from configuration step 4.
5. The flow from A to I in downstream are discarded at the ONU U interface at step 9

Remarks

- None.

6.2 Frame Mapping and QoS

6.2.1 Single U-interface with multiple downstream GEM ports

Test Name

Single U-interface with multiple downstream GEM ports

Test Definition ID

ONU.6.2.1

Reference Document

BBF TR-156 [20]

ITU-T G.988 [6][7][8]

Test Type

Conformance

Test Requirement Type

Mandatory

Unit Under Test

ONU

Requirement Description**BBF TR-156:**

- **R-19** The ONU MUST support mapping traffic from one or more GEM Ports to a U-interface in the downstream direction.
- **R-31** The ONU MUST support mapping traffic from one or more GEM Ports to a U interface in the downstream direction.
- **R-41** The ONU MUST support mapping traffic from one or more GEM Ports to a **U** interface in the downstream direction.

Test Objective

The purpose of this test is to verify the ONU's OMCI implementation, support the minimum functionality to configure a single U-interface on the ONU and associate that U-interface with downstream flows from multiple GEM ports. This test verifies both the OMCI configuration responses and support of active user traffic. In the downstream direction, GEM ports, identified by Port-IDs, are used to differentiate traffic classes. This test verifies the ONU's ability to receive downstream traffic through multiple GEM ports and forward that traffic out a single U-interface. This test does not verify the performance of the traffic classifier or scheduler.

Test Configuration

1. ONU is powered and connected to ODN.
2. ONU has been activated by the OLT Emulator, has been ranged, and a GEM port for OMCI has been created as a result of ONU-ID assignment.
3. The Ethernet Traffic Generator and the OLT Emulator should be configured to transmit two streams of Ethernet frames downstream, with frames transmitted in each stream and the following parameters applied to each stream:
 - a. Stream 1:
 - MAC destination address: 10:22:33:44:55:aa
 - MAC source address: 10:22:33:44:55:66
 - Frames transmitted on GEM Port 1
 - b. Stream 2:
 - MAC destination address: 10:22:33:44:55:bb
 - MAC source address: 10:22:33:44:55:cc
 - Frames transmitted on GEM Port 2

Downstream Direction																							
Traffic Stream	S/R Interface														U Interface								
	MAC DA	MAC SA	Outer VLAN Tag				Inner VLAN Tag				Ethertype	IP DA	IP SA	GEM	Outer VLAN Tag				Inner VLAN Tag				UNI
	Value	Value	TPID	Pbits	DEI	VID	TPID	Pbits	CFI or DEI	VID	Value	Value	Value	Port #	TPID	Pbits	DEI	VID	TPID	Pbits	CFI or DEI	VID	Port #
A	MAC1	MAC2	n/a	n/a	n/a	n/a	0x8100	SPbits1	0	SVID1	x	x	x	GEM1	n/a	n/a	n/a	n/a	0x8100	SPbits1	0	SVID1	1
B	MAC3	MAC4	n/a	n/a	n/a	n/a	0x8100	SPbits2	0	SVID1	x	x	x	GEM2	n/a	n/a	n/a	n/a	0x8100	SPbits2	0	SVID1	1

Test Procedure

1. Select random value for GEM Port 1, which shall not be a value typically reserved for special purposes.
2. Select random value for GEM Port 2, which shall not be a value typically reserved for special purposes.
3. Configure the OLT Emulator to use the message sequence below to provision the ONU to support:
 - a. A single tagged U-interface, with no translation of VID values
 - b. Two GEM ports (1 & 2), each associated with the above U-interface
4. Cause the OLT Emulator to request the ONU upload its current MIB.
5. Enable any frame capture mechanisms on the Ethernet Traffic Generator.
6. Cause the Ethernet Traffic Generator and the OLT Emulator to transmit the downstream frames (both streams), where the Ethernet frames of stream 1 are carried in GEM frames addressed to first GEM port and the Ethernet frames of stream 2 are carried in GEM frames addressed to the second GEM port.

OMCI Procedure Details

Refer to clause 4.3.

Pass/Fail Criteria

The test passes if the following are true, otherwise the test fails:

1. Each OMCI response message should indicate success for the associated create or set command.
2. The uploaded ONU MIB should be consistent with the MIB held in the OLT Emulator.
3. All downstream frames should have been received error free for both streams.

Remarks

- No MAC filtering should be enabled on the ONU during these tests, or it should be configured to allow the test user traffic to pass through the ONU.

6.2.2 User Isolation on ONU Devices with Multiple U-interfaces

Test Name

User Isolation on ONU Devices with Multiple U-interfaces

Test Definition ID

ONU.6.2.2

Reference Document

BBF TR-156 [20]

BBF TR-101 [16]

ITU-T G.988 [6][7][8]

Test Type

Conformance

Test Requirement Type

Conditionally Mandatory (if ONT has multiple user ports)

Unit Under Test

ONU

Requirement Description

BBF TR-101:

- **R-40** The Access Node MUST be able to prevent forwarding traffic between user ports (user isolation). This behavior MUST be configurable per S-VID.

BBF TR-156:

- **R-3** The OLT MUST support user isolation as defined in TR-101¹

¹User isolation at the ONU is an inherent feature of the TR-156 [12] architecture.

Test Objective

The purpose of this test is to verify an ONU with multiple U-interfaces (one subscriber per interface), typically used for the MDU and MTU deployment scenarios depicted in TR-156, does not forward traffic between the U-interfaces when the G-PON has been configured to support user isolation.

Test Configuration

1. ONU is powered and connected to ODN
2. ONU has been activated by the OLT Emulator, has been ranged, and a GEM port for OMCI has been created as a result of ONU-ID assignment.

3. The OLT Emulator has instructed the ONU to reset its MIB to factory default values.
4. The Ethernet Traffic Generator should be configured to untagged Ethernet frames upstream, towards U-interface A (shown above) with the following parameters:

Upstream Direction																								
Traffic Stream	U Interface												R/S Interface											
	UNI	MAC DA	MAC SA	Outer VLAN Tag				Inner VLAN Tag				Ethertype	IP DA	IP SA	Outer VLAN Tag				Inner VLAN Tag				GEM	T-CONT
	Port #	Value	Value	TPID	Pbits	DEI	VID	TPID	Pbits	CFI or DEI	VID	Value	Value	Value	TPID	Pbits	DEI	VID	TPID	Pbits	CFI or DEI	VID	Port #	Number
A	1	MAC1	MAC2	n/a	n/a	n/a	n/a	n/a	n/a	n/a	n/a	0x0800	x	x	n/a	n/a	n/a	n/a	0x88A8	SPbits1	x	SVID1	GEM1	TCONT1
B	2	MAC2	MAC1	n/a	n/a	n/a	n/a	n/a	n/a	n/a	n/a	0x0800	x	x	n/a	n/a	n/a	n/a	0x88A8	SPbits2	x	SVID1	GEM2	TCONT2

5. The Ethernet Traffic Generator should be configured to untagged Ethernet frames upstream, towards U-interface B (shown above)
6. Only 1 user traffic class should be configured on the ONU (via defined OMCI messages below), requiring 1 GEM port (Alloc-ID, T-CONT, Port-ID).

Test Procedure

1. Configure the OLT Emulator to use the message sequence below to provision the ONU to support:
 - a. Two untagged U-interfaces on the same VLAN
 - b. User isolation on the above VLAN
2. Select unicast values for MAC1 through MAC2, which are not already in use by the ONU or other connected devices.
3. Cause the OLT Emulator to request the ONU upload its current MIB.
4. Enable any frame capture mechanisms on the Ethernet Traffic Generator.
5. Cause the Ethernet Traffic Generator to transmit upstream frame(s) to each U-interface as described above.

OMCI Procedure Details

Refer to clause 4.3.

Pass/Fail Criteria

The test passes if the following are true, otherwise the test fails:

1. Each OMCI response message shall indicate success for the associated create or set command.
2. The uploaded ONU MIB shall be consistent with the MIB held in the OLT Emulator.
3. All frames must be received at the OLT Emulator.
4. No downstream frames may be received at the U interfaces.

Remarks

- No MAC filtering should be enabled on the ONU during these tests, or it should be configured to allow the test user traffic to pass through the ONU.

6.2.3 Mapping Traffic from GEM Ports to U Interface in the Downstream Direction in a VBES Architecture

Test Name

Mapping Traffic from GEM Ports to U Interface in the Downstream Direction in a VBES Architecture

Test Definition Number

ONU.6.2.3

Reference Document

BBF TR-156 [20]

ITU-T G.988 [6][7][8]

Test Type

Conformance

Test Requirement Type

Mandatory

Unit Under Test

ONU

Requirement Description**BBF TR-156:**

- **R-41** The ONU MUST support mapping traffic from one or more GEM Ports to a U-interface in the downstream direction

Test Objective

- Verify that the ONU supports mapping traffic from one or more GEM Ports to a U-interface in the downstream direction

Test Configuration

1. OLT Emulator and ONU under test are powered and connected to ODN
2. ONU under test has been activated by the OLT Emulator, has been ranged, and a GEM port for OMCI has been created as a result of ONU-ID assignment.
3. The Ethernet Traffic Generator and the OLT Emulator are configured to transmit double-tagged Ethernet frames downstream with the following parameters (Stream 1)
4. The Ethernet Traffic Generator and the OLT Emulator are configured to transmit double-tagged Ethernet frames downstream with the following parameters (Stream 2)

Downstream Direction																							
Traffic Stream	S/R Interface														U Interface								
	MAC DA	MAC SA	Outer VLAN Tag				Inner VLAN Tag				Ethertype	IP DA	IP SA	GEM	Outer VLAN Tag				Inner VLAN Tag				UNI
	Value	Value	TPID	Pbits	DEI	VID	TPID	Pbits	CFI or DEI	VID	Value	Value	Value	Port #	TPID	Pbits	DEI	VID	TPID	Pbits	CFI or DEI	VID	Port #
A	MAC1	MAC2	0x88A8	SPbits1	0	SVID1	0x8100	x	x	CVID1	x	x	x	GEM1	n/a	n/a	n/a	n/a	0x8100	x	x	CVID1	1
B	MAC1	MAC2	0x88A8	SPbits1	0	SVID2	0x8100	x	x	CVID2	x	x	x	GEM2	n/a	n/a	n/a	n/a	0x8100	x	x	CVID2	1

Test Procedure

1. Select distinct random values for CVID1, CVID2, SVID1, SVID2, and SPbits1
2. Select distinct random values for the unicast MAC Addresses MAC1 and MAC2
3. Use the OLT Emulator to provision the ONU under test (via defined OMCI messages below) to support one VBES subscriber with two user traffic classes, requiring 2 GEM ports (Alloc-IDs, T-CONTs, Port-IDs).
4. Enable any frame monitoring/capture mechanisms on the Ethernet Traffic Generator/Analyzer.
5. Cause the Ethernet Traffic Generator and the OLT Emulator to transmit downstream traffic with the characteristics described in the test configuration section.

OMCI Procedure Details

Refer to clause 4.3.

Pass/Fail Criteria

The test passes if the following are true, otherwise the test fails:

1. Each OMCI response message must indicate success for the associated create or set command.
2. The uploaded ONU MIB must be consistent with the MIB held in the OLT Emulator
3. All downstream frames sent by the Ethernet Traffic Generator and the OLT Emulator must be received by the Ethernet Traffic Emulator/Generator at the U-interface

Remarks

- None.

6.2.4 Mapping traffic into GEM Ports based on P-bit values in the upstream direction (single user port)

Test Name

Mapping traffic into GEM Ports based on P-bit values in the upstream direction (single user port)

Test Definition Number

ONU.6.2.4

Reference Document

BBF TR-156 [20]

ITU-T G.988 [6][7][8]

Test Type

Conformance

Test Requirement Type

Mandatory

Unit Under Test

ONU

Requirement Description

BBF TR-156:

- **R-51** The ONU MUST support mapping traffic into GEM Ports based on arbitrary combination of user port, VID and P-bit values in the upstream direction.
- **R-52** The ONU MUST NOT prevent multiple P-bit values being used in the same VLAN.
- **R-53** The ONU MUST NOT prevent multiple VLANs from using the same P-bits.
- **Also, R-6, 7.**

Test Objective

Show that ONU can map upstream traffic to GEM ports from P-bit values. Also show that there are no restrictions on multiple P-bit values in the same VLAN, nor on multiple VLANs using the same P-bit value.

Test Configuration

For this test, only a single user port is assumed.

ONU must be set-up with the standard L2 OCM (single user) with two upstream queues and two associated T-CONTs. The intent of the test is to define four flows based on different combinations of received VIDs and P-bits at the U-interface. Each flow will map to the specified GEM port and T-CONT; tags will not be modified. The flows and their corresponding tags, GEM ports and T-CONTs are given in the table below.

Upstream Direction																								
Traffic Stream	U Interface												R/S Interface											
	UNI	MAC DA	MAC SA	Outer VLAN Tag				Inner VLAN Tag				Ethertype	IP DA	IP SA	Outer VLAN Tag				Inner VLAN Tag				GEM	T-CONT
	Port #	Value	Value	TPID	Pbits	DEI	VID	TPID	Pbits	CFI or DEI	VID	Value	Value	Value	TPID	Pbits	DEI	VID	TPID	Pbits	CFI or DEI	VID	Port #	Number
A	1	MAC1	MAC2	n/a	n/a	n/a	n/a	0x8100	CPbits1	x	CVID1	x	x	x	n/a	n/a	n/a	n/a	0x8100	CPbits1	x	CVID1	GEM1	TCONT1
B	1	MAC1	MAC2	n/a	n/a	n/a	n/a	0x8100	CPbits2	x	CVID1	x	x	x	n/a	n/a	n/a	n/a	0x8100	CPbits2	x	CVID1	GEM2	TCONT2
C	1	MAC1	MAC2	n/a	n/a	n/a	n/a	0x8100	CPbits1	x	CVID2	x	x	x	n/a	n/a	n/a	n/a	0x8100	CPbits1	x	CVID2	GEM1	TCONT1
D	1	MAC1	MAC2	n/a	n/a	n/a	n/a	0x8100	CPbits2	x	CVID2	x	x	x	n/a	n/a	n/a	n/a	0x8100	CPbits2	x	CVID2	GEM2	TCONT2

Test Procedure

For each stream in the above table, inject C-tagged traffic at the U-interface with the specified VID and P-bit values. Verify that this traffic is mapped to the specified GEM port and TCONT and that a C-tag is present with the specified VID and P-bit values.

OMCI Procedure Details

Refer to clause 4.3.

Pass/Fail Criteria

The test passes if the following are true, otherwise the test fails:

1. All OMCI commands have Success responses
2. A MIB upload and compare matches the MIB expected by the OLT
3. The resulting GEM port, TCONT, and C-tag (VID and P-bit) in each of the streams above are as specified.

Remarks

- None.

6.2.5 Mapping traffic into GEM Ports based on VID values in the upstream direction (single user port)

Test Name

Mapping traffic into GEM Ports based on VID values in the upstream direction (single user port)

Test Definition Number

ONU.6.2.5

Reference Document

BBF TR-156 [20]

ITU-T G.988 [6][7][8]

Test Type

Conformance

Test Requirement Type

Mandatory

Unit Under Test

ONU

Requirement Description

BBF TR-156:

- **R-51** The ONU MUST support mapping traffic into GEM Ports based on arbitrary combination of user port, VID and P-bit values in the upstream direction.
- **R-52** The ONU MUST NOT prevent multiple P-bit values being used in the same VLAN.
- **R-53** The ONU MUST NOT prevent multiple VLANs from using the same P-bits.
- **Also, R-6, 7.**

Test Objective

Show that ONU can map upstream traffic to GEM ports and T-CONTs from VID values. Also show that there are no restrictions on multiple P-bit values in the same VLAN, nor on multiple VLANs using the same P-bit value.

Test Configuration

For this test, only a single user port is assumed.

ONU must be set-up with the standard L2 OCM (single user) with two queues and two associated T-CONTs. The intent of the test is to define four flows based on different combinations of received VIDs and P-bits at the U-interface. Each flow will map to the specified GEM port and T-CONT; tags will not be modified. The flows and their corresponding tags, GEM ports and T-CONTs are given in the table below.

Upstream Direction																								
Traffic Stream	U Interface													R/S Interface										
	UNI	MAC DA	MAC SA	Outer VLAN Tag				Inner VLAN Tag				Ethertype	IP DA	IP SA	Outer VLAN Tag				Inner VLAN Tag				GEM	T-CONT
	Port #	Value	Value	TPID	Pbits	DEI	VID	TPID	Pbits	CFI or DEI	VID	Value	Value	Value	TPID	Pbits	DEI	VID	TPID	Pbits	CFI or DEI	VID	Port #	Number
A	1	MAC1	MAC2	n/a	n/a	n/a	n/a	0x8100	CPbits1	x	CVID1	x	x	x	n/a	n/a	n/a	n/a	0x8100	CPbits1	x	CVID1	GEM1	TCONT1
B	1	MAC1	MAC2	n/a	n/a	n/a	n/a	0x8100	CPbits2	x	CVID1	x	x	x	n/a	n/a	n/a	n/a	0x8100	CPbits2	x	CVID1	GEM1	TCONT1
C	1	MAC1	MAC2	n/a	n/a	n/a	n/a	0x8100	CPbits1	x	CVID2	x	x	x	n/a	n/a	n/a	n/a	0x8100	CPbits1	x	CVID2	GEM2	TCONT2
D	1	MAC1	MAC2	n/a	n/a	n/a	n/a	0x8100	CPbits2	x	CVID2	x	x	x	n/a	n/a	n/a	n/a	0x8100	CPbits2	x	CVID2	GEM2	TCONT2

Test Procedure

For each stream in the above table, inject C-tagged traffic at the U-interface with the specified VID and P-bit values. Verify that this traffic is mapped to the specified GEM port and TCONT and that a C-tag is present with the specified VID and P-bit values.

OMCI Procedure Details

Refer to clause 4.3.

Pass/Fail Criteria

The test passes if the following are true, otherwise the test fails:

1. All OMCI commands have Success responses
2. A MIB upload and compare matches the MIB expected by the OLT
3. The resulting GEM port, TCONT, and C-tag (VID and P-bit) in each of the streams above are as specified.

Remarks

- None.

6.2.6 Mapping traffic into GEM Ports based on VID & P-bit values in the upstream direction (single user port)

Test Name

Mapping traffic into GEM Ports based on VID & P-bit values in the upstream direction (single user port)

Test Definition Number

ONU.6.2.6

Reference Document

BBF TR-156 [20]

ITU-T G.988 [6][7][8]

Test Type

Conformance

Test Requirement Type

Mandatory

Unit Under Test

ONU

Requirement Description

BBF TR-156:

- **R-51** The ONU MUST support mapping traffic into GEM Ports based on arbitrary combination of user port, VID and P-bit values in the upstream direction.
- **R-52** The ONU MUST NOT prevent multiple P-bit values being used in the same VLAN.
- **R-53** The ONU MUST NOT prevent multiple VLANs from using the same P-bits.
- **Also, R-6, 7, 46, 57, 67.**

Test Objective

Show that ONU can map upstream traffic to GEM ports and T-CONTs from VID & P-bit values. Also show that there are no restrictions on multiple P-bit values in the same VLAN, nor on multiple VLANs using the same P-bit value.

Test Configuration

For this test, only a single user port is assumed.

ONU must be set-up with the standard L2 OCM (single user) with four queues and four associated T-CONTs. The intent of the test is to define four flows based on different combinations of received VIDs and P-bits at the U-interface. Each flow will map to the specified GEM port and T-CONT; tags will not be modified. The flows and their corresponding tags, GEM ports and T-CONTs are given in the table below.

Upstream Direction																								
Traffic Stream	U Interface														R/S Interface									
	UNI	MAC DA	MAC SA	Outer VLAN Tag				Inner VLAN Tag			Ethertype	IP DA	IP SA	Outer VLAN Tag				Inner VLAN Tag				GEM	T-CONT	
	Port #	Value	Value	TPID	Pbits	DEI	VID	TPID	Pbits	CFI or DEI	VID	Value	Value	Value	TPID	Pbits	DEI	VID	TPID	Pbits	CFI or DEI	VID	Port #	Number
A	1	MAC1	MAC2	n/a	n/a	n/a	n/a	0x8100	CPbits1	x	CVID1	x	x	x	n/a	n/a	n/a	n/a	0x8100	CPbits1	x	CVID1	GEM1	TCONT1
B	1	MAC1	MAC2	n/a	n/a	n/a	n/a	0x8100	CPbits2	x	CVID1	x	x	x	n/a	n/a	n/a	n/a	0x8100	CPbits2	x	CVID1	GEM2	TCONT2
C	1	MAC1	MAC2	n/a	n/a	n/a	n/a	0x8100	CPbits1	x	CVID2	x	x	x	n/a	n/a	n/a	n/a	0x8100	CPbits1	x	CVID2	GEM3	TCONT3
D	1	MAC1	MAC2	n/a	n/a	n/a	n/a	0x8100	CPbits2	x	CVID2	x	x	x	n/a	n/a	n/a	n/a	0x8100	CPbits2	x	CVID2	GEM4	TCONT4

Test Procedure

For each stream in the above table, inject C-tagged traffic at the U-interface with the specified VID and P-bit values. Verify that this traffic is mapped to the specified GEM port and TCONT and that a C-tag is present with the specified VID and P-bit values.

OMCI Procedure Details

Refer to clause 4.3.

Pass/Fail Criteria

The test passes if the following are true, otherwise the test fails:

1. All OMCI commands have Success responses
2. A MIB upload and compare matches the MIB expected by the OLT
3. The resulting GEM port, TCONT, and C-tag (VID and P-bit) in each of the streams above are as specified.

Remarks

- None.

6.2.7 Mapping traffic into GEM Ports based on P-bit values in the upstream direction (multiple user port)

Test Name

Mapping traffic into GEM Ports based on P-bit values in the upstream direction (multiple user port)

Test Definition Number

ONU.6.2.7

Reference Document

BBF TR-156 [20]

ITU-T G.988 [6][7][8]

Test Type

Conformance

Test Requirement Type

Conditionally Mandatory (if ONT has multiple user ports).

Unit Under Test

ONU

Requirement Description

BBF TR-156:

- **R-51** The ONU MUST support mapping traffic into GEM Ports based on arbitrary combination of user port, VID and P-bit values in the upstream direction.
- **R-52** The ONU MUST NOT prevent multiple P-bit values being used in the same VLAN.
- **R-53** The ONU MUST NOT prevent multiple VLANs from using the same P-bits.
- **Also, R-6, 7.**

Test Objective

Show that ONU can map upstream traffic to GEM ports and T-CONTs from P-bit values. Also show that there are no restrictions on multiple P-bit values in the same VLAN, nor on multiple VLANs using the same P-bit value.

Test Configuration

ONU must be set-up with the standard L2 OCM (multiple user) with two queues and two associated T-CONTs. The intent of the test is to define eight flows based on different combinations of received VLANs and P-bits and user port. Each flow will map to the specified GEM port and T-CONT; tags will not be modified. The flows and their corresponding tags, GEM ports and T-CONTs are given in the table below.

Upstream Direction																									
Traffic Stream	U Interface													R/S Interface											
	UNI	MAC DA	MAC SA	Outer VLAN Tag				Inner VLAN Tag				Ethertype	IP DA	IP SA	Outer VLAN Tag				Inner VLAN Tag				GEM	T-CONT	
	Port #	Value	Value	TPID	Pbits	DEI	VID	TPID	Pbits	CFI or DEI	VID	Value	Value	Value	TPID	Pbits	DEI	VID	TPID	Pbits	CFI or DEI	VID	Port #	Number	
A	1	MAC1	MAC2	n/a	n/a	n/a	n/a	0x8100	CPbits1	x	CVID1	x	x	x	n/a	n/a	n/a	n/a	0x8100	CPbits1	x	CVID1	GEM1	TCONT1	
B	1	MAC1	MAC2	n/a	n/a	n/a	n/a	0x8100	CPbits2	x	CVID1	x	x	x	n/a	n/a	n/a	n/a	0x8100	CPbits2	x	CVID1	GEM2	TCONT2	
C	1	MAC1	MAC2	n/a	n/a	n/a	n/a	0x8100	CPbits1	x	CVID2	x	x	x	n/a	n/a	n/a	n/a	0x8100	CPbits1	x	CVID2	GEM1	TCONT1	
D	1	MAC1	MAC2	n/a	n/a	n/a	n/a	0x8100	CPbits2	x	CVID2	x	x	x	n/a	n/a	n/a	n/a	0x8100	CPbits2	x	CVID2	GEM2	TCONT2	
E	2	MAC3	MAC4	n/a	n/a	n/a	n/a	0x8100	CPbits1	x	CVID1	x	x	x	n/a	n/a	n/a	n/a	0x8100	CPbits1	x	CVID1	GEM3	TCONT1	
F	2	MAC3	MAC4	n/a	n/a	n/a	n/a	0x8100	CPbits2	x	CVID1	x	x	x	n/a	n/a	n/a	n/a	0x8100	CPbits2	x	CVID1	GEM4	TCONT2	
G	2	MAC3	MAC4	n/a	n/a	n/a	n/a	0x8100	CPbits1	x	CVID2	x	x	x	n/a	n/a	n/a	n/a	0x8100	CPbits1	x	CVID2	GEM3	TCONT1	
H	2	MAC3	MAC4	n/a	n/a	n/a	n/a	0x8100	CPbits2	x	CVID2	x	x	x	n/a	n/a	n/a	n/a	0x8100	CPbits2	x	CVID2	GEM4	TCONT2	

Test Procedure

For each stream in the above table, inject C-tagged traffic at the specified U-interface with the specified VID and P-bit values. Verify that this traffic is mapped to the specified GEM port and TCONT and that a C-tag is present with the specified VID and P-bit values.

OMCI Procedure Details

Refer to clause 4.3.

Pass/Fail Criteria

The test passes if the following are true, otherwise the test fails:

1. All OMCI commands have Success responses
2. A MIB upload and compare matches the MIB expected by the OLT
3. The resulting GEM port, TCONT, and C-tag (VID and P-bit) in each of the streams above are as specified.

Remarks

- None.

6.2.8 Mapping traffic into GEM Ports based on VID values in the upstream direction (multiple user port)

Test Name

Mapping traffic into GEM Ports based on VID values in the upstream direction (multiple user port)

Test Definition Number

ONU.6.2.8

Reference Document

BBF TR-156 [20]

ITU-T G.988 [6][7][8]

Test Type

Conformance

Test Requirement Type

Conditionally Mandatory (if ONT has multiple user ports)

Unit Under Test

ONU

Requirement Description

BBF TR-156:

- **R-51** The ONU MUST support mapping traffic into GEM Ports based on arbitrary combination of user port, VID and P-bit values in the upstream direction.
- **R-52** The ONU MUST NOT prevent multiple P-bit values being used in the same VLAN.
- **R-53** The ONU MUST NOT prevent multiple VLANs from using the same P-bits.
- **Also, R-6, 7.**

Test Objective

Show that ONU can map upstream traffic to GEM ports and T-CONTs from VID values. Also show that there are no restrictions on multiple P-bit values in the same VLAN, nor on multiple VLANs using the same P-bit value.

Test Configuration

ONU must be set-up with the standard L2 OCM (multiple user) with two queues and two associated T-CONTs. The intent of the test is to define eight flows based on different combinations of received VIDs and P-bits and user port. Each flow will map to the specified GEM port and T-CONT; tags will not be modified. The flows and their corresponding tags, GEM ports and T-CONTs are given in the table below.

Upstream Direction																								
Traffic Stream	U Interface														R/S Interface									
	UNI	MAC DA	MAC SA	Outer VLAN Tag				Inner VLAN Tag			Ethertype	IP DA	IP SA	Outer VLAN Tag				Inner VLAN Tag				GEM	T-CONT	
	Port #	Value	Value	TPID	Pbits	DEI	VID	TPID	Pbits	CFI or DEI	VID	Value	Value	Value	TPID	Pbits	DEI	VID	TPID	Pbits	CFI or DEI	VID	Port #	Number
A	1	MAC1	MAC2	n/a	n/a	n/a	n/a	0x8100	CPbits1	x	CVID1	x	x	x	n/a	n/a	n/a	n/a	0x8100	CPbits1	x	CVID1	GEM1	TCONT1
B	1	MAC1	MAC2	n/a	n/a	n/a	n/a	0x8100	CPbits2	x	CVID1	x	x	x	n/a	n/a	n/a	n/a	0x8100	CPbits2	x	CVID1	GEM1	TCONT1
C	1	MAC1	MAC2	n/a	n/a	n/a	n/a	0x8100	CPbits1	x	CVID2	x	x	x	n/a	n/a	n/a	n/a	0x8100	CPbits1	x	CVID2	GEM2	TCONT2
D	1	MAC1	MAC2	n/a	n/a	n/a	n/a	0x8100	CPbits2	x	CVID2	x	x	x	n/a	n/a	n/a	n/a	0x8100	CPbits2	x	CVID2	GEM2	TCONT2
E	2	MAC3	MAC4	n/a	n/a	n/a	n/a	0x8100	CPbits1	x	CVID1	x	x	x	n/a	n/a	n/a	n/a	0x8100	CPbits1	x	CVID1	GEM3	TCONT1
F	2	MAC3	MAC4	n/a	n/a	n/a	n/a	0x8100	CPbits2	x	CVID1	x	x	x	n/a	n/a	n/a	n/a	0x8100	CPbits2	x	CVID1	GEM3	TCONT1
G	2	MAC3	MAC4	n/a	n/a	n/a	n/a	0x8100	CPbits1	x	CVID2	x	x	x	n/a	n/a	n/a	n/a	0x8100	CPbits1	x	CVID2	GEM4	TCONT2
H	2	MAC3	MAC4	n/a	n/a	n/a	n/a	0x8100	CPbits2	x	CVID2	x	x	x	n/a	n/a	n/a	n/a	0x8100	CPbits2	x	CVID2	GEM4	TCONT2

Test Procedure

For each stream in the above table, inject C-tagged traffic at the specified U-interface with the specified VID and P-bit values. Verify that this traffic is mapped to the specified GEM port and TCONT and that a C-tag is present with the specified VID and P-bit values.

OMCI Procedure Details

Refer to clause 4.3.

Pass/Fail Criteria

The test passes if the following are true, otherwise the test fails:

1. All OMCI commands have Success responses
2. A MIB upload and compare matches the MIB expected by the OLT
3. The resulting GEM port, TCONT, and C-tag (VID and P-bit) in each of the streams above are as specified.

Remarks

- None.

6.2.9 Mapping traffic into GEM Ports based on VID & P-bit values in the upstream direction (multiple user port)

Test Name

Mapping traffic into GEM Ports based on VID & P-bit values in the upstream direction (multiple user port)

Test Definition Number

ONU.6.2.9

Reference Document

BBF TR-156 [20]

ITU-T G.988 [6][7][8]

Test Type

Conformance

Test Requirement Type

Conditionally Mandatory (if ONT has multiple user ports)

Unit Under Test

ONU

Requirement Description

BBF TR-156

- **R-51** The ONU MUST support mapping traffic into GEM Ports based on arbitrary combination of user port, VID and P-bit values in the upstream direction.
- **R-52** The ONU MUST NOT prevent multiple P-bit values being used in the same VLAN.
- **R-53** The ONU MUST NOT prevent multiple VLANs from using the same P-bits.
- **Also, R-6, 7, 46, 57, 67.**

Test Objective

Show that ONU can map upstream traffic to GEM ports and T-CONTs from VID & P-bit values. Also show that there are no restrictions on multiple P-bit values in the same VLAN, nor on multiple VLANs using the same P-bit value.

Test Configuration

ONU must be set-up with the standard L2 OCM (multiple user) with four queues and four associated T-CONTs. The intent of the test is to define eight flows based on different combinations of received VIDs and P-bits and user ports. Each flow will map to the specified GEM port and T-CONT; tags will not be modified. The flows and their corresponding tags, GEM ports and T-CONTs are given in the table below.

Upstream Direction																								
Traffic Stream	U Interface													R/S Interface										
	UNI	MAC DA	MAC SA	Outer VLAN Tag				Inner VLAN Tag				Ethertype	IP DA	IP SA	Outer VLAN Tag				Inner VLAN Tag				GEM	T-CONT
	Port #	Value	Value	TPID	Pbits	DEI	VID	TPID	Pbits	CFI or DEI	VID	Value	Value	Value	TPID	Pbits	DEI	VID	TPID	Pbits	CFI or DEI	VID	Port #	Number
A	1	MAC1	MAC2	n/a	n/a	n/a	n/a	0x8100	CPbits1	x	CVID1	x	x	x	n/a	n/a	n/a	n/a	0x8100	CPbits1	x	CVID1	GEM1	TCONT1
B	1	MAC1	MAC2	n/a	n/a	n/a	n/a	0x8100	CPbits2	x	CVID1	x	x	x	n/a	n/a	n/a	n/a	0x8100	CPbits2	x	CVID1	GEM2	TCONT2
C	1	MAC1	MAC2	n/a	n/a	n/a	n/a	0x8100	CPbits1	x	CVID2	x	x	x	n/a	n/a	n/a	n/a	0x8100	CPbits1	x	CVID2	GEM3	TCONT3
D	1	MAC1	MAC2	n/a	n/a	n/a	n/a	0x8100	CPbits2	x	CVID2	x	x	x	n/a	n/a	n/a	n/a	0x8100	CPbits2	x	CVID2	GEM4	TCONT4
E	2	MAC3	MAC4	n/a	n/a	n/a	n/a	0x8100	CPbits1	x	CVID1	x	x	x	n/a	n/a	n/a	n/a	0x8100	CPbits1	x	CVID1	GEM5	TCONT1
F	2	MAC3	MAC4	n/a	n/a	n/a	n/a	0x8100	CPbits2	x	CVID1	x	x	x	n/a	n/a	n/a	n/a	0x8100	CPbits2	x	CVID1	GEM6	TCONT2
G	2	MAC3	MAC4	n/a	n/a	n/a	n/a	0x8100	CPbits1	x	CVID2	x	x	x	n/a	n/a	n/a	n/a	0x8100	CPbits1	x	CVID2	GEM7	TCONT3
H	2	MAC3	MAC4	n/a	n/a	n/a	n/a	0x8100	CPbits2	x	CVID2	x	x	x	n/a	n/a	n/a	n/a	0x8100	CPbits2	x	CVID2	GEM8	TCONT4

Test Procedure

For each stream in the above table, inject -tagged traffic at the specified U-interface with the specified VID and P-bit values. Verify that this traffic is mapped to the specified GEM port and TCONT and that a C-tag is present with the specified VID and P-bit values.

OMCI Procedure Details

Refer to clause 4.3.

Pass/Fail Criteria

The test passes if the following are true, otherwise the test fails:

1. All OMCI commands have Success responses
2. A MIB upload and compare matches the MIB expected by the OLT
3. The resulting GEM port, TCONT, and C-tag (VID and P-bit) in each of the streams above are as specified.

Remarks

- None.

6.2.10 Mapping multiple P-bit values to the same GEM port (single user port)

Test Name

Mapping multiple P-bit values to the same GEM port (single user port)

Test Definition Number

ONU.6.2.10

Reference Document

BBF TR-156 [20]

ITU-T G.988 [6][7][8]

Test Type

Conformance

Test Requirement Type

Mandatory

Unit Under Test

ONU

Requirement Description

BBF TR-156:

- **R-51** The ONU MUST support mapping traffic into GEM ports based on arbitrary combination of user port, VID and P-bit values in the upstream direction.
- **Also, R-6, R-7**

Test Objective

Demonstrate that ONU can map multiple P-bit values to the same GEM port.

Test Configuration

1. OLT Emulator and ONU under test are powered and connected to ODN
2. ONU under test has been activated by the OLT Emulator, has been ranged, and a GEM port for OMCI has been created as a result of ONU-ID assignment.
3. A single user port is assumed
4. ONU must be set-up with the standard L2 OMCI Common Model (single user) with two upstream queues and TCONTs.

5. The intent of the test is to demonstrate that multiple P-bit values at the U-interface can be mapped to the same GEM port. Four upstream flows are mapped into two GEM ports and T-CONTs based on four different P-bit values at the U-interface. Tags will not be modified.
6. The flows and their corresponding tags, GEM ports and T-CONTs are given in the table below.

Upstream Direction																								
Traffic Stream	U Interface												R/S Interface											
	UNI	MAC DA	MAC SA	Outer VLAN Tag				Inner VLAN Tag				Ethertype	IP DA	IP SA	Outer VLAN Tag				Inner VLAN Tag				GEM	T-CONT
	Port #	Value	Value	TPID	Pbits	DEI	VID	TPID	Pbits	CFI or DEI	VID	Value	Value	Value	TPID	Pbits	DEI	VID	TPID	Pbits	CFI or DEI	VID	Port #	Number
A	1	MAC1	MAC2	n/a	n/a	n/a	n/a	0x8100	CPbits1	x	CVID1	x	x	x	n/a	n/a	n/a	n/a	0x8100	CPbits1	x	CVID1	GEM1	TCONT1
B	1	MAC1	MAC2	n/a	n/a	n/a	n/a	0x8100	CPbits2	x	CVID1	x	x	x	n/a	n/a	n/a	n/a	0x8100	CPbits2	x	CVID1	GEM1	TCONT1
C	1	MAC1	MAC2	n/a	n/a	n/a	n/a	0x8100	CPbits3	x	CVID1	x	x	x	n/a	n/a	n/a	n/a	0x8100	CPbits3	x	CVID1	GEM2	TCONT2
D	1	MAC1	MAC2	n/a	n/a	n/a	n/a	0x8100	CPbits4	x	CVID1	x	x	x	n/a	n/a	n/a	n/a	0x8100	CPbits4	x	CVID1	GEM2	TCONT2

7. All untagged upstream traffic from the U-interface should be silently discarded

Test Procedure

1. Inject tagged traffic at the U-interface with the specified P-bit values and random VID values
2. Verify that P-bit values are correctly mapping into the right GEM ports and T-CONTs at the S/R-interface.

OMCI Procedure Details

Refer to clause 4.3.

Pass/Fail Criteria

The test passes if the following are true, otherwise the test fails:

1. All OMCI commands have Success responses
2. For each flow, the resulting GEM port matches the specifications detailed in the previous table

Remarks

- None.

6.2.11 Test Case Reserved For Future Use

6.2.12 Strict priority downstream scheduling among 4 queues on ONU

Test Name

Strict priority downstream scheduling among 4 queues on ONU

Test Definition Number

ONU.6.2.12

Reference Document

BBF TR-156 [20]

ITU-T G.988 [6][7][8]

Test Type

Conformance

Test Requirement Type

Conditionally Mandatory. Mandatory if ONU shows a PON throughput capacity greater (strictly) than the nominal negotiated link speed from the U interface of the ONU.

Unit Under Test

ONU

Requirement Description

BBF TR-156:

- **R-56** In the downstream direction, the ONU MUST support at least 4 queues per user port, one per traffic class
- **R-63** The OLT and ONU MUST support scheduling of downstream queues according to strict priority among at least 4 TCs.
- **R-64** The OLT and ONU MUST support assigning an individual TC to a downstream queue.

Also

- **R-46:** The OLT and ONU MUST support at least 4 traffic classes for Ethernet frames.

Test Objective

To verify that the ONU implementation supports four queues on the downstream direction, that each queue can be assigned to one specific traffic class and that it supports strict priority scheduling among those four traffic classes.

Test Configuration

1. OLT Emulator and ONU under test are connected to the ODN and powered on.

2. ONU activation and OMCC establishment processes have been successfully completed.
3. The OLT Emulator will be configured to send the sequence of OMCI messages required to provision the ONU under test
 - to support 4 traffic classes, each one associated to a different P-bit value
 - with 4 GEM ports and 4 downstream queues, each pair of GEM port-downstream queue assigned to one traffic classes
 - with strict priority scheduling between the four downstream queues
4. The Ethernet Traffic Generator and the OLT Emulator will be configured to transmit four interleaved flows of double-tagged Ethernet frames with the parameters in the next table. Also, GEM port mapping is shown. Tags won't be modified on the ONU; expected frame format at the U-interface is also shown in the table.

Downstream Direction																								
Traffic Stream	S/R Interface														U Interface									
	MAC DA	MAC SA	Outer VLAN Tag				Inner VLAN Tag				Ethertype	IP DA	IP SA	GEM	Outer VLAN Tag				Inner VLAN Tag				UNI	
	Value	Value	TPID	Pbits	DEI	VID	TPID	Pbits	CFI or DEI	VID	Value	Value	Value	Port #	TPID	Pbits	DEI	VID	TPID	Pbits	CFI or DEI	VID	Port #	
A	MAC1	MAC2	n/a	n/a	n/a	n/a	0x8100	CPbits1	x	CVID1	x	x	x	GEM1	n/a	n/a	n/a	n/a	0x8100	CPbits1	x	CVID1	1	
B	MAC3	MAC4	n/a	n/a	n/a	n/a	0x8100	CPbits2	x	CVID1	x	x	x	GEM2	n/a	n/a	n/a	n/a	0x8100	CPbits2	x	CVID1	1	
C	MAC5	MAC6	n/a	n/a	n/a	n/a	0x8100	CPbits3	x	CVID1	x	x	x	GEM3	n/a	n/a	n/a	n/a	0x8100	CPbits3	x	CVID1	1	
D	MAC7	MAC8	n/a	n/a	n/a	n/a	0x8100	CPbits4	x	CVID1	x	x	x	GEM4	n/a	n/a	n/a	n/a	0x8100	CPbits4	x	CVID1	1	

Test Procedure

1. Select random value for CVID1 between 1 and 4094.
2. Select different distinct random values for CPbits1 through CPbits4 between 0 and 7. Note.- Traffic class 1 will have the highest priority and traffic class 4 the lowest.
3. Select distinct random values for unicast MAC addresses MAC1 through MAC8.
4. Cause the OLT Emulator to send the configured OMCI message sequence to provision the ONU.
5. Enable any frame capture mechanism on the Ethernet traffic generator.
6. Cause the Ethernet Traffic Generator and the OLT Emulator to send the configured traffic flows. Initially, the four streams will be sent at the same bit rate and the total bit rate will be below the maximum bandwidth available at the U-interface.
7. Gradually increase the bit rate of traffic stream A until no frames from traffic stream D are received on the Ethernet traffic generator.
8. Gradually increase the bit rate of traffic stream A until no frames from traffic stream C are received on the Ethernet traffic generator.
9. Gradually increase the bit rate of traffic stream A until no frames from traffic stream B are received on the Ethernet traffic generator.

OMCI Procedure Details

Refer to clause 4.3.

Pass/Fail Criteria

The test passes if the following are true, otherwise the test fails:

1. During ONU provisioning, each OMCI response message indicates success for the associated create or set command.
2. At step 6 of the test procedure, all the sent downstream frames of traffic streams from A to D are received at the Ethernet traffic generator, error free.
3. At step 7 of the test procedure, at the Ethernet traffic generator:
 - All frames from traffic streams A and B are received error free.
 - At least some of the frames from traffic stream C are received, all of them error free.
 - No frames from traffic stream D are received.
4. At step 8 of the test procedure, at the Ethernet traffic generator:
 - All frames from traffic stream A are received error free.
 - At least some of the frames from traffic stream B are received, all of them error free.
 - No frames from traffic streams D and C are received.
5. At step 9 of the test procedure, at the Ethernet traffic generator:
 - At least some of the frames from traffic stream A are received, all of them error free.
 - No frames from traffic streams D, C and B are received.

Remarks

- This test case is designed to overload the UNI in the downstream resulting in frame discard. As the downstream frame rate increases, the frame loss for the lower priority frames should be observed at the UNI. Therefore, the tester should select a line rate for the UNI that is below the overall throughput capacity of the ONU under test.

6.2.13 Indicating drop precedence using P-bits upstream

Test Name

Indicating drop precedence using P-bits upstream

Test Definition Number

ONU.6.2.13

Reference Document

BBF TR-156 [20]

ITU-T G.988 [6][7][8]

Test Type

Conformance

Test Requirement Type

Mandatory

Unit Under Test

ONU

Requirement Description**TR-156:**

- **R-54** The OLT and ONU MUST support drop precedence within at least 2 traffic classes and MUST support configurable mapping to these classes and drop precedence from the 8 possible values of the Ethernet P-bits.

Test Objective

Show that ONU can implement drop precedence using P-bits upstream

Test Configuration

ONU must be set-up with the standard L2 OCM (single user) with two upstream queues and two associated T-CONTs. ONU queues are set up with the following: drop precedence indication = PCP 6P2D; yellow thresholds set to half the queue size; green thresholds set to the queue size. The intent of the test is to define four flows, two per traffic class. For each traffic class, one of the flows is marked with drop precedence. Each T-CONT should be serviced at a fixed rate, E. Each flow rate is set to $R=0.7E$.

The U-interface and S/R-interface values for each test are shown below, along with the GEM port and T-CONT configuration.

Upstream Direction																									
Traffic Stream	U Interface													R/S Interface											
	UNI	MAC DA	MAC SA	Outer VLAN Tag				Inner VLAN Tag					Ethertype	IP DA	IP SA	Outer VLAN Tag				Inner VLAN Tag				GEM	T-CONT
	Port #	Value	Value	TPID	Pbits	DEI	VID	TPID	Pbits	CFI or DEI	VID	Value	Value	Value	TPID	Pbits	DEI	VID	TPID	Pbits	CFI or DEI	VID	Port #	Number	
A*	1	MAC1	MAC2	n/a	n/a	n/a	n/a	0x8100	2	x	SVID1	x	x	x	n/a	n/a	n/a	n/a	0x8100	2	x	SVID1	GEM1	TCONT1	
B	1	MAC1	MAC2	n/a	n/a	n/a	n/a	0x8100	3	x	SVID1	x	x	x	n/a	n/a	n/a	n/a	0x8100	3	x	SVID1	GEM1	TCONT1	
C*	1	MAC1	MAC2	n/a	n/a	n/a	n/a	0x8100	4	x	SVID1	x	x	x	n/a	n/a	n/a	n/a	0x8100	4	x	SVID1	GEM2	TCONT2	
D	1	MAC1	MAC2	n/a	n/a	n/a	n/a	0x8100	5	x	SVID1	x	x	x	n/a	n/a	n/a	n/a	0x8100	5	x	SVID1	GEM2	TCONT2	

* Drop Precedence Flow

Test Procedure

For each traffic stream pair (A&B, C&D), inject streams at the U-interface, each of rate R, tagged as shown in the table above. The flow rate shall be set to R=0.7E. Verify at the S/R-interface that the only packets dropped are from streams marked with drop precedence.

OMCI Procedure Details

Refer to clause 4.3.

Pass/Fail Criteria

The test passes if the following are true, otherwise the test fails:

1. All OMCI commands have Success responses
2. A MIB upload and compare matches the MIB expected by the OLT
3. Verify at the S/R-interface that the only packets dropped are from streams marked with drop precedence.

Remarks

- None.

6.2.14 Indicating drop precedence using DEI bit upstream

Test Name

Indicating drop precedence using DEI bit upstream

Test Definition Number

ONU.6.2.14

Reference Document

BBF TR-156 [20]

ITU-T G.988 [6][7][8]

Test Type

Conformance

Test Requirement Type

Mandatory

Unit Under Test

ONU

Requirement Description

TR-156:

- **R-55** The OLT and ONU MUST support drop precedence within all supported traffic classes based on the DEI bit value of the 802.1ad header.

Test Objective

Show that ONU can implement drop precedence using DEI bit upstream

Test Configuration

ONU must be set-up with the standard L2 OCM (single user) with four upstream queues and four associated T-CONTs. ONU queues are set up with the following: drop precedence indication = DEI; yellow thresholds set to half the queue size; green thresholds set to the queue size. The intent of the test is to define eight flows, two per traffic class. For each traffic class, one of the flows is marked with drop precedence. Each T-CONT should to be serviced at a fixed rate, E. Each flow is set to rate $R=0.7E$.

The U-interface and S/R-interface values for each test are shown below, along with the GEM port and T-CONT configuration.

Upstream Direction																								
Traffic Stream	U Interface													R/S Interface										
	UNI	MAC DA	MAC SA	Outer VLAN Tag				Inner VLAN Tag				Ethertype	IP DA	IP SA	Outer VLAN Tag				Inner VLAN Tag				GEM	T-CONT
	Port #	Value	Value	TPID	Pbits	DEI	VID	TPID	Pbits	CFI or DEI	VID	Value	Value	Value	TPID	Pbits	DEI	VID	TPID	Pbits	CFI or DEI	VID	Port #	Number
A*	1	MAC1	MAC2	n/a	n/a	n/a	n/a	0x8100	SPbits1	1	SVID1	x	x	x	n/a	n/a	n/a	n/a	0x8100	SPbits1	1	SVID1	GEM1	TCONT1
B	1	MAC1	MAC2	n/a	n/a	n/a	n/a	0x8100	SPbits1	0	SVID1	x	x	x	n/a	n/a	n/a	n/a	0x8100	SPbits1	0	SVID1	GEM1	TCONT1
C*	1	MAC1	MAC2	n/a	n/a	n/a	n/a	0x8100	SPbits2	1	SVID1	x	x	x	n/a	n/a	n/a	n/a	0x8100	SPbits2	1	SVID1	GEM2	TCONT2
D	1	MAC1	MAC2	n/a	n/a	n/a	n/a	0x8100	SPbits2	0	SVID1	x	x	x	n/a	n/a	n/a	n/a	0x8100	SPbits2	0	SVID1	GEM2	TCONT2
E*	1	MAC1	MAC2	n/a	n/a	n/a	n/a	0x8100	SPbits3	1	SVID1	x	x	x	n/a	n/a	n/a	n/a	0x8100	SPbits3	1	SVID1	GEM3	TCONT3
F	1	MAC1	MAC2	n/a	n/a	n/a	n/a	0x8100	SPbits3	0	SVID1	x	x	x	n/a	n/a	n/a	n/a	0x8100	SPbits3	0	SVID1	GEM3	TCONT3
G*	1	MAC1	MAC2	n/a	n/a	n/a	n/a	0x8100	SPbits4	1	SVID1	x	x	x	n/a	n/a	n/a	n/a	0x8100	SPbits4	1	SVID1	GEM4	TCONT4
H	1	MAC1	MAC2	n/a	n/a	n/a	n/a	0x8100	SPbits4	0	SVID1	x	x	x	n/a	n/a	n/a	n/a	0x8100	SPbits4	0	SVID1	GEM4	TCONT4

* Drop Precedence Flow

Test Procedure

For each traffic stream pair (A&B, C&D, E&F, G&H), inject streams at the U-interface, each of rate R, tagged as shown in the table above. The flow rate shall be set to R=0.7E. Verify at the S/R-interface that the only packets dropped are from streams marked with drop precedence.

OMCI Procedure Details

Refer to clause 4.3.

Pass/Fail Criteria

The test passes if the following are true, otherwise the test fails:

1. All OMCI commands have Success responses
2. A MIB upload and compare matches the MIB expected by the OLT
3. Verify at the S/R-interface that the only packets dropped are from flows marked with drop precedence.

Remarks

- None.

6.2.15 Indicating drop precedence using P-bits downstream

Test Name

Indicating drop precedence using P-bits downstream

Test Definition Number

ONU.6.2.15

Reference Document

BBF TR-156 [20]

ITU-T G.988 [6][7][8]

Test Type

Conformance

Test Requirement Type

Conditionally Mandatory. Mandatory if ONU shows a PON throughput capacity greater (strictly) than the nominal negotiated link speed from the U interface of the ONU.

Unit Under Test

ONU

Requirement Description

TR-156:

- **R-54** The OLT and ONU MUST support drop precedence within at least 2 traffic classes and MUST support configurable mapping to these classes and drop precedence from the 8 possible values of the Ethernet P-bits.

Test Objective

Show that ONU can implement drop precedence using P-bits downstream

Test Configuration

1. ONU must be set-up with the standard L2 OCM (single user) with two downstream queues. ONU queues are set up with the following: drop precedence indication = PCP 6P2D; yellow thresholds set to half the queue size; green thresholds set to the queue size. The intent of the test is to define four flows, two per traffic class. For each traffic class, one of the flows is marked with drop precedence. For a user port egress rate of E, each flow rate is set to $R=0.7E$.
2. The U-interface and S/R-interface values for each test are shown below, along with the GEM port configuration.

Downstream Direction																							
Traffic Stream	S/R Interface														U Interface								
	MAC DA	MAC SA	Outer VLAN Tag				Inner VLAN Tag				Ethertype	IP DA	IP SA	GEM	Outer VLAN Tag				Inner VLAN Tag				UNI
	Value	Value	TPID	Pbits	DEI	VID	TPID	Pbits	CFI or DEI	VID	Value	Value	Value	Port #	TPID	Pbits	DEI	VID	TPID	Pbits	CFI or DEI	VID	Port #
A*	MAC1	MAC2	n/a	n/a	n/a	n/a	0x8100	2	x	SVID1	x	x	x	GEM1	n/a	n/a	n/a	n/a	0x8100	2	x	SVID1	1
B	MAC1	MAC2	n/a	n/a	n/a	n/a	0x8100	3	x	SVID1	x	x	x	GEM1	n/a	n/a	n/a	n/a	0x8100	3	x	SVID1	1
C*	MAC1	MAC2	n/a	n/a	n/a	n/a	0x8100	4	x	SVID1	x	x	x	GEM2	n/a	n/a	n/a	n/a	0x8100	4	x	SVID1	1
D	MAC1	MAC2	n/a	n/a	n/a	n/a	0x8100	5	x	SVID1	x	x	x	GEM2	n/a	n/a	n/a	n/a	0x8100	5	x	SVID1	1

* Drop Precedence Flow

Test Procedure

For each traffic stream pair (A&B, C&D) inject streams at the S/R-interface, each of rate R, tagged as shown in the table above. The flow rate shall be set to $R=0.7E$, where E is the user port egress rate. Verify at the U-interface that the only packets dropped are from streams marked with drop precedence.

OMCI Procedure Details

Refer to clause 4.3.

Pass/Fail Criteria

The test passes if the following are true, otherwise the test fails:

1. All OMCI commands have Success responses
2. A MIB upload and compare matches the MIB expected by the OLT
3. Verify at the U-interface that the only packets dropped are from streams marked with drop precedence.

Remarks

- None.

6.2.16 Indicating drop precedence using DEI bit downstream

Test Name

Indicating drop precedence using DEI bit downstream

Test Definition Number

ONU.6.2.16

Reference Document

BBF TR-156 [20]

ITU-T G.988 [6][7][8]

Test Type

Conformance

Test Requirement Type

Conditionally Mandatory. Mandatory if ONU shows a PON throughput capacity greater (strictly) than the nominal negotiated link speed from the U interface of the ONU.

Unit Under Test

ONU

Requirement Description

TR-156:

- **R-55** The OLT and ONU MUST support drop precedence within all supported traffic classes based on the DEI bit value of the 802.1ad header.

Test Objective

Show that ONU can implement drop precedence using DEI bit downstream

Test Configuration

1. ONU must be set-up with the standard L2 OCM (single user) with four downstream queues. ONU queues are set up with the following: drop precedence indication = DEI; yellow thresholds set to half the queue size; green thresholds set to the queue size. The intent of the test is to define eight flows, two per traffic class. For each traffic class, one of the flows is marked with drop precedence. For a user port egress rate of E, each flow rate is set to $R=0.7E$.
2. The U-interface and S/R-interface values for each test are shown below, along with the GEM port configuration.

Downstream Direction																							
Traffic Stream	S/R Interface														U Interface								
	MAC DA	MAC SA	Outer VLAN Tag				Inner VLAN Tag				Ethertype	IP DA	IP SA	GEM	Outer VLAN Tag				Inner VLAN Tag				UNI
	Value	Value	TPID	Pbits	DEI	VID	TPID	Pbits	CFI or DEI	VID	Value	Value	Value	Port #	TPID	Pbits	DEI	VID	TPID	Pbits	CFI or DEI	VID	Port #
A*	MAC1	MAC2	n/a	n/a	n/a	n/a	0x8100	SPbits1	1	SVID1	x	x	x	GEM1	n/a	n/a	n/a	n/a	0x8100	SPbits1	1	SVID1	1
B	MAC1	MAC2	n/a	n/a	n/a	n/a	0x8100	SPbits1	0	SVID1	x	x	x	GEM1	n/a	n/a	n/a	n/a	0x8100	SPbits1	0	SVID1	1
C*	MAC1	MAC2	n/a	n/a	n/a	n/a	0x8100	SPbits2	1	SVID1	x	x	x	GEM2	n/a	n/a	n/a	n/a	0x8100	SPbits2	1	SVID1	1
D	MAC1	MAC2	n/a	n/a	n/a	n/a	0x8100	SPbits2	0	SVID1	x	x	x	GEM2	n/a	n/a	n/a	n/a	0x8100	SPbits2	0	SVID1	1
E*	MAC1	MAC2	n/a	n/a	n/a	n/a	0x8100	SPbits3	1	SVID1	x	x	x	GEM3	n/a	n/a	n/a	n/a	0x8100	SPbits3	1	SVID1	1
F	MAC1	MAC2	n/a	n/a	n/a	n/a	0x8100	SPbits3	0	SVID1	x	x	x	GEM3	n/a	n/a	n/a	n/a	0x8100	SPbits3	0	SVID1	1
G*	MAC1	MAC2	n/a	n/a	n/a	n/a	0x8100	SPbits4	1	SVID1	x	x	x	GEM4	n/a	n/a	n/a	n/a	0x8100	SPbits4	1	SVID1	1
H	MAC1	MAC2	n/a	n/a	n/a	n/a	0x8100	SPbits4	0	SVID1	x	x	x	GEM4	n/a	n/a	n/a	n/a	0x8100	SPbits4	0	SVID1	1

* Drop Precedence Flow

Test Procedure

For each traffic stream pair (A&B, C&D, E&F, G&H), inject streams at the S/R-interface, each of rate R, tagged as shown in the table above. The flow rate shall be set to $R=0.7E$, where E is the user port egress rate. Verify at the U-interface that the only packets dropped are from streams marked with drop precedence.

OMCI Procedure Details

Refer to clause 4.3.

Pass/Fail Criteria

The test passes if the following are true, otherwise the test fails:

1. All OMCI commands have Success responses
2. A MIB upload and compare matches the MIB expected by the OLT
3. Verify at the U-interface that the only packets dropped are from streams marked with drop precedence.

Remarks

- None.

6.2.17 Test Case Reserved For Future Use

6.2.18 Test Case Reserved For Future Use

6.2.19 Mapping Traffic from GEM Ports to Multiple U Interfaces in the Downstream Direction

Test Name

Mapping Traffic from GEM Ports to Multiple U Interfaces in the Downstream Direction

Test Definition Number

ONU.6.2.19

Reference Document

BBF TR-156 [20]

ITU-T G.988 [6][7][8]

Test Type

Conformance

Test Requirement Type

Conditionally Mandatory. Mandatory if Multiple U Interfaces are supported by the ONU.

Unit Under Test

ONU

Requirement Description

BBF TR-156:

- **R-41** The ONU MUST support mapping traffic from one or more GEM Ports to a U-interface in the downstream direction
- **R-31** The ONU MUST support mapping traffic from one or more GEM Ports to a U interface in the downstream direction.
- **R-19** The ONU MUST support mapping traffic from one or more GEM Ports to a U interface in the downstream direction.

Test Objective

- Verify that the ONU supports mapping traffic from GEM Ports to multiple U-interfaces in the downstream direction

Test Configuration

1. OLT Emulator and ONU under test are powered and connected to ODN
2. ONU under test has been activated by the OLT Emulator, has been ranged, and a GEM port for OMCI has been created as a result of ONU-ID assignment.
3. The Ethernet Traffic Generator and the OLT Emulator are configured to transmit S-tagged Ethernet frames downstream with the following parameters (Stream 1)
4. The Ethernet Traffic Generator and the OLT Emulator are configured to transmit S-tagged Ethernet frames downstream with the following parameters (Stream 2)

Downstream Direction																							
Traffic Stream	S/R Interface														U Interface								
	MAC DA	MAC SA	Outer VLAN Tag				Inner VLAN Tag				Ethertype	IP DA	IP SA	GEM	Outer VLAN Tag				Inner VLAN Tag			UNI	
	Value	Value	TPID	Pbits	DEI	VID	TPID	Pbits	CFI or DEI	VID	Value	Value	Value	Port #	TPID	Pbits	DEI	VID	TPID	Pbits	CFI or DEI	VID	Port #
A	MAC1	MAC2	n/a	n/a	n/a	n/a	0x8100	SPbits1	x	SVID1	x	x	x	GEM1	n/a	n/a	n/a	n/a	0x8100	Spbits1	x	SVID1	1
B	MAC3	MAC2	n/a	n/a	n/a	n/a	0x8100	SPbits1	x	SVID1	x	x	x	GEM2	n/a	n/a	n/a	n/a	0x8100	Spbits1	x	SVID1	2

Test Procedure

1. Select distinct random values for, SVID1 and SPbits1
2. Select distinct random values for the unicast MAC Addresses MAC1, MAC2 and MAC3
3. Use the OLT Emulator to provision the ONU under test (via defined OMCI messages below) to support two subscribers with one user traffic class, requiring 2 GEM ports (Alloc-IDs, T-CONTs, Port-IDs).
4. Enable any frame monitoring/capture mechanisms on the Ethernet Traffic Generator/Analyzer.
5. Cause the Ethernet Traffic Generator and the OLT Emulator to transmit downstream traffic with the characteristics described in the test configuration section.

OMCI Procedure Details

Refer to clause 4.3.

Pass/Fail Criteria

The test passes if the following are true, otherwise the test fails:

1. Each OMCI response message must indicate success for the associated create or set command.
2. The uploaded ONU MIB must be consistent with the MIB held in the OLT Emulator
3. All downstream frames sent by the Ethernet Traffic Generator and the OLT Emulator on GEM1 must be received by the Ethernet Traffic Generator/Analyzer at the U-interface 1 but not at U-interface 2.
4. All downstream frames sent by the Ethernet Traffic Generator and the OLT Emulator on GEM2 must be received by the Ethernet Traffic Generator/Analyzer at the U-interface 2 but not at U-interface 1.

Remarks

- None.

6.2.20 Test Case Reserved For Future Use

6.2.21 Mapping Traffic from GEM Ports to Multiple U Interfaces in the Downstream Direction

Test Name

Mapping Traffic from GEM Ports to Multiple U Interfaces in the Downstream Direction

Test Definition Number

ONU.6.2.21

Reference Document

BBF TR-156 [20]

ITU-T G.988 [6][7][8]

Test Type

Conformance

Test Requirement Type

Conditionally Mandatory. Mandatory if Multiple U Interfaces are supported by the ONU.

Unit Under Test

ONU

Requirement Description

BBF TR-156:

- **R-31** The ONU MUST support mapping traffic from one or more GEM Ports to a U-interface in the downstream direction
- **R-19** The ONU MUST support mapping traffic from one or more GEM Ports to a U-interface in the downstream direction.
- **R-41** The ONU MUST support mapping traffic from one or more GEM Ports to a U-interface in the downstream direction.

Test Objective

- Verify that the ONU supports mapping traffic from GEM Ports to multiple U-interfaces in the downstream direction

Test Configuration

1. OLT Emulator and ONU under test are powered and connected to ODN
2. ONU under test has been activated by the OLT Emulator, has been ranged, and a GEM port for OMCI has been created as a result of ONU-ID assignment.
3. The Ethernet Traffic Generator and the OLT Emulator are configured to transmit tagged Ethernet frames downstream with the following parameters (Stream 1)

4. The Ethernet Traffic Generator and the OLT Emulator are configured to transmit tagged Ethernet frames downstream with the following parameters (Stream 2)
5. The Ethernet Traffic Generator and the OLT Emulator are configured to transmit tagged Ethernet frames downstream with the following parameters (Stream 3)

Downstream Direction																							
Traffic Stream	S/R Interface														U Interface								
	MAC DA	MAC SA	Outer VLAN Tag				Inner VLAN Tag				Ethertype	IP DA	IP SA	GEM	Outer VLAN Tag				Inner VLAN Tag				UNI
	Value	Value	TPID	Pbits	DEI	VID	TPID	Pbits	CFI or DEI	VID	Value	Value	Value	Port #	TPID	Pbits	DEI	VID	TPID	Pbits	CFI or DEI	VID	Port #
A	MAC1	MAC2	n/a	n/a	n/a	n/a	0x8100	CPbits1	x	CVID1	x	x	x	GEM1	n/a	n/a	n/a	n/a	0x8100	CPbits1	x	CVID1	1
B	MAC3	MAC4	n/a	n/a	n/a	n/a	0x8100	CPbits2	x	CVID1	x	x	x	GEM2	n/a	n/a	n/a	n/a	0x8100	CPbits2	x	CVID1	1
C	MAC1	MAC2	n/a	n/a	n/a	n/a	0x8100	CPbits1	x	CVID2	x	x	x	GEM3	n/a	n/a	n/a	n/a	0x8100	CPbits1	x	CVID2	2

* In the upstream direction, mapping to traffic classes is done using C-Tag P-bits

Test Procedure

1. Select distinct random values for CVID1, CVID2, CPbits1 and CPbits2
2. Select distinct random values for the unicast MAC Addresses MAC1 through MAC4
3. Use the OLT Emulator to provision the ONU under test (via defined OMCI messages below) to support two 1:1 subscribers with two user traffic classes, requiring 3 GEM ports (Alloc-IDs, T-CONTs, Port-IDs).
4. Enable any frame monitoring/capture mechanisms on the Ethernet Traffic Generator/Analyzer.
5. Cause the Ethernet Traffic Generator and the OLT Emulator to transmit downstream traffic with the characteristics described in the test configuration section.

OMCI Procedure Details

Refer to clause 4.3.

Pass/Fail Criteria

The test passes if the following are true, otherwise the test fails:

1. Each OMCI response message must indicate success for the associated create or set command.
2. The uploaded ONU MIB must be consistent with the MIB held in the OLT Emulator
3. All downstream frames sent by the Ethernet Traffic Generator and the OLT Emulator on GEM1 must be received error free by the Ethernet Traffic Generator/Analyzer at the U-interface 1
4. All downstream frames sent by the Ethernet Traffic Generator and the OLT Emulator on GEM2 must be received error free by the Ethernet Traffic Generator/Analyzer at the U-interface 1

5. All downstream frames sent by the Ethernet Traffic Generator and the OLT Emulator on GEM3 must be received error free by the Ethernet Traffic Generator/Analyzer at the U-interface 2

Remarks

- None.

6.2.22 Test Case Reserved For Future Use

6.2.23 Test Case Reserved For Future Use

6.2.24 Test Case Reserved For Future Use

6.2.25 Strict Priority Downstream Scheduling Among 2 Queues on ONU with Unicast and Multicast Traffic

Test Name

Strict Priority Downstream Scheduling Among 2 Queues on ONU with Unicast and Multicast Traffic

Test Definition Number

ONU.6.2.25

Reference Document

BBF TR-156 [20]

ITU-T G.988 [6][7][8]

Test Type

Conformance

Test Requirement Type

Conditionally Mandatory. Mandatory if ONU shows a PON throughput capacity greater (strictly) than the achievable throughput from the U interface of the ONU.

Unit Under Test

ONU

Requirement Description

BBF TR-156

- **R-56** In the downstream direction, the ONU MUST support at least 4 queues per user port, one per traffic class
- **R-63** The OLT and ONU MUST support scheduling of downstream queues according to strict priority among at least 4 TCs
- **R-64** The OLT and ONU MUST support assigning an individual TC to a downstream queue

Also

- **R-46** The OLT and ONU MUST support at least 4 traffic classes for Ethernet frames

Test Objective

To verify that the strict priority scheduling among two traffic classes, independently of the traffic being unicast or multicast.

Test Configuration

1. OLT Emulator and ONU are powered on and connected to ODN

2. The ONU under test has been activated by the OLT Emulator, has been ranged, and a GEM port for OMCI has been created as a result of ONU-ID assignment
3. A single U-interface is used
4. The OLT Emulator will be configured to send the sequence of OMCI messages required to provision the ONU under test
 - with support of 2 traffic classes (i.e., P-bit mapping), each one associated to a different P-bit value
 - with the highest priority given to the traffic class 1 and the lowest to the traffic class 2
 - with 1 bidirectional GEM port, referred below as GEM1, and 1 downstream queue, this pair of GEM port-downstream queue assigned to one traffic class
 - with a multicast GEM port, referred below as GEM2, between the ONU under test and the OLT Emulator, for multicast Ethernet frames and 1 corresponding downstream queue, this pair of GEM port-downstream queue assigned to one traffic class
 - the GEM port / traffic class mapping will be modified during the test

Note: The IGMP version is IGMPv2

5. The Traffic Generator and OLT Emulator will be configured to transmit one interleaved flow of double-tagged Ethernet frames with the parameters in the next table. Also, GEM port mapping is shown. Tags won't be modified on the ONU; expected frame format at the U-interface is also shown in the table

Downstream Direction																							
Traffic Stream	S/R Interface														U Interface								
	MAC DA	MAC SA	Outer VLAN Tag				Inner VLAN Tag				Ethertype	IP DA	IP SA	GEM	Outer VLAN Tag				Inner VLAN Tag				UNI
	Value	Value	TPID	Pbits	DEI	VID	TPID	Pbits	CFI or DEI	VID	Value	Value	Value	Port #	TPID	Pbits	DEI	VID	TPID	Pbits	CFI or DEI	VID	Port #
A	MAC1	MAC2	n/a	n/a	n/a	n/a	0x8100	CPbits1	x	CVID1	x	x	x	GEM1	n/a	n/a	n/a	n/a	0x8100	CPbits1	n/a	CVID1	1

6. The Traffic Generator should be configured to transmit the downstream multicast Ethernet frames as defined below:

Channel	Multicast source IP address	Multicast IP group address	Multicast MAC group address	VID	P-bit
Ch1	IP-S1	IP-G1	MAC-G1	SVID1	SPbit1

Test Procedure

1. Select random value for CVID1 between 1 and 4094
2. Select distinct random values for CPbits1 between 0 and 7
3. Select distinct random values for unicast MAC addresses MAC1 to MAC2
4. Cause the OLT Emulator to send the configured OMCI message sequence to provision the ONU with GEM1 mapped to traffic class 1

5. Cause the Traffic Generator to send the configured unicast traffic flow
6. Select random value for IP addresses: IP-S1
7. Select distinct random value for multicast IP group addresses: IP-G1
8. Use associated random multicast MAC addresses: MAC-G1
9. Select a random value for SVID1 between 1 and 4094
10. Select a random value for SPbit1 between 0 and 7
11. Configure the OLT Emulator to forward the multicast traffic to the multicast GEM Port permanently (GEM2). Cause the OLT Emulator to send the configured OMCI message sequence to provision the ONU with GEM2 mapped to traffic class 2
12. Cause the OLT Emulator to configure the dynamic access list control table of Multicast Operation Profile ME at the ONU (table index IND1)

Table Index	VLAN ID	Multicast source IP address	Multicast IP group address
IND1	SVID1	0.0.0.0	IP-G1

13. At the U-interface send IGMP message to join channel Ch1.
14. Initially, the unicast and multicast streams will be sent at the same bit rate and the total bit rate will be below the maximum bandwidth available at the U-interface
15. Gradually increase the bit rate of unicast and multicast streams until losses of frames for multicast stream appears on the Ethernet Traffic Generator
16. Cause the Traffic Generator to stop the configured unicast traffic flow
17. At the U-interface send IGMP message to leave channel Ch1.
18. Cause the OLT Emulator to send a MIB reset at the ONU
19. Cause the OLT Emulator to send the configured OMCI message sequence to provision the ONU with GEM1 mapped in traffic class 2
20. Cause the Traffic Generator to send the configured unicast traffic flow
21. Configure the OLT Emulator to forward the multicast traffic to the multicast GEM Port permanently (GEM2). Cause the OLT Emulator to send the configured OMCI message sequence to provision the ONU with GEM2 mapped to traffic class 1
22. At the U-interface send IGMP message to join channel Ch1.
23. Initially, the unicast and multicast streams will be sent at the same bit rate and the total bit rate will be below the maximum bandwidth available at the U-interface
24. Gradually increase the bit rate of unicast and multicast streams until losses of frames for unicast stream appears on the Ethernet Traffic Generator
25. Cause the Traffic Generator to stop the configured unicast traffic flow
26. At the U-interface send IGMP message to leave channel Ch1.

27. Cause the OLT Emulator to send a MIB reset at the ONU
28. Cause the OLT Emulator to send the configured OMCI message sequence to provision the ONU with GEM1 mapped in traffic class 2
29. Cause the Traffic Generator to send the configured unicast traffic flow
30. Configure the OLT Emulator to forward the multicast traffic to the multicast GEM Port permanently (GEM2). Cause the OLT Emulator to send the configured OMCI message sequence to provision the ONU with GEM2 mapped to traffic class 2
31. At the U-interface send IGMP message to join channel Ch1.
32. Initially, the unicast and multicast streams will be sent at the same bit rate and the total bit rate will be below the maximum bandwidth available at the U-interface
33. Gradually increase the bit rate of unicast and multicast streams until losses of frames for unicast and multicast stream appears on the Ethernet Traffic Generator

OMCI Procedure Details

Refer to clause 4.3.

Pass/Fail Criteria

The test passes if the following are true, otherwise the test fails:

1. All OMCI commands have success responses
2. The U-interface receives the unicast flow at step 5
3. The U-interface does not receive the multicast flow Ch1 at step 11
4. The U-interface receives the unicast and multicast flows at step 13
5. There is no loss of frames for both unicast and multicast flows at the U-interface at step 14
6. There is only loss of frames for the multicast flow at the U-interface at step 15
7. The U-interface does not receive the unicast flow at step 16
8. The U-interface does not receive the multicast flow Ch1 at step 17
9. The ONU is able to perform MIB reset successfully at step 18
10. The U-interface receives the unicast flow at step 20
11. The U-interface receives the unicast and multicast flows at step 22
12. There is no loss of frames for both unicast and multicast flows at the U-interface at step 23

13. There is only loss of frames for the unicast flow at the U-interface at step 24
14. The U-interface does not receive the unicast flow at step 25
15. The U-interface does not receive the multicast flow Ch1 at step 26
16. The ONU is able to perform MIB reset successfully at step 27
17. The U-interface receives the unicast flow at step 29
18. The U-interface receives the unicast and multicast flows at step 31
19. There is no loss of frames for both unicast and multicast flows at the U-interface at step 32
20. There is loss of frames for the unicast and multicast flows at the U-interface at step 33

Remarks

- None.

6.3 IGMP Controlled Multicast

6.3.1 ONU passing of downstream IGMP messages

Test Name

ONU passing of downstream IGMP messages

Test Definition Number

ONU.6.3.1

Reference Document

BBF TR-156 [20]

ITU-T G.988 [6][7][8]

Test Type

Conformance

Test Requirement Type

Mandatory

Unit Under Test

ONU

Requirement Description**BBF TR-156:**

- **R-81** The ONU MUST support receiving downstream multicast IGMP messages (e.g., Global Query messages) on either a unicast GEM port, or the multicast GEM port that is used to carry the multicast content.

Test Objective

To verify that the ONU implementation supports receiving and passing IGMP messages received on either the downstream multicast GEM port or a unicast GEM port.

Test Configuration

1. OLT Emulator and ONU under test are connected to the ODN and powered on.
2. ONU activation and OMCC establishment processes have been successfully completed.
3. The OLT Emulator has instructed the ONU to reset its MIB to factory default values

4. The OLT Emulator will be configured to send the sequence of OMCI messages required to provision the ONU under test to support the following configuration:
 - Single untagged U-interface (removal of S-Tag from downstream packets and addition of S-Tag to upstream packets).
 - One unicast GEM port
 - One downstream multicast GEM port
5. The Ethernet Traffic Generator and the OLT Emulator will be configured to transmit two downstream IGMP global/general query message. The first IGMP message will be transmitted to the unicast GEM port, and will be carried within a GEM encapsulated Ethernet frame that includes the provisioned S-Tag VLAN header. The second IGMP message will be transmitted to the multicast GEM port, and will be carried within a GEM encapsulated Ethernet frame that includes the provisioned S-Tag VLAN header.
6. The Ethernet traffic generator will be configured to report/capture the receipt of the IGMP messages.

Test Procedure

1. Select random value for VID1 between 1 and 4094. The VID shall be used as the VID of the S-Tag noted in the above configuration.
2. Cause the OLT Emulator to send the configured OMCI message sequence to provision the ONU.
3. Enable any frame capture mechanism on the Ethernet traffic generator.
4. Cause the Ethernet Traffic Generator and the OLT Emulator to send an IGMP global/general query message to the unicast GEM port. The IGMP message shall be encapsulated within a S-Tagged Ethernet frame. The group address and number of sources fields within the IGMP message should both be all zeros.
5. Verify the Ethernet traffic generator received the IGMP query message.
6. Cause the Ethernet Traffic Generator and the OLT Emulator to send an IGMP global/general query message to the multicast GEM port. The IGMP message shall be encapsulated within a S-Tagged Ethernet frame. The group address and number of sources fields within the IGMP message should both be all zeros.
7. Verify the Ethernet traffic generator received the IGMP query message.

OMCI Procedure Details

Refer to clause 4.3.

Pass/Fail Criteria

The test passes if the following are true, otherwise the test fails:

1. During ONU provisioning, each OMCI response message indicates success for the associated create or set command.
2. The uploaded ONU MIB must be consistent with the MIB held in the OLT Emulator
3. The IGMP global/general query message transmitted to the unicast GEM port was received by the Ethernet traffic generator and was contained within an untagged Ethernet frame.

4. The IGMP global/general query message transmitted to the multicast GEM port was received by the Ethernet traffic generator and was contained within an untagged Ethernet frame.

Remarks

- It is the responsibility of the tester to ensure it is possible to verify which received IGMP message corresponds to which transmitted message (i.e., at the Ethernet traffic generator, the two received frames will appear identical).

6.3.2 Test Case Reserved For Future Use

6.3.3 ONU silent discarding of IGMPv1 messages

Test Name

ONU silent discarding of IGMPv1 messages

Test Definition Number

ONU.6.3.3

Reference Document

BBF TR-156 [20]

ITU-T G.988 [6][7][8]

Test Type

Conformance

Test Requirement Type

Mandatory

Unit Under Test

ONU

Requirement Description**BBF TR-156:**

- **R-98** The ONU MUST silently discard IGMP v1 messages.

Test Objective

To verify that the ONU implementation supports silently discarding of IGMPv1 messages.

Test Configuration

1. OLT Emulator and ONU under test are connected to the ODN and powered on.
2. ONU activation and OMCC establishment processes have been successfully completed.
3. The OLT Emulator has instructed the ONU to reset its MIB to factory default values
4. The OLT Emulator will be configured to send the sequence of OMCI messages required to provision the ONU under test to support the following configuration:
 - Single untagged U-interface (removal of S-Tag from downstream packets and addition of S-Tag to upstream packets).
 - One unicast GEM port
 - One downstream multicast GEM port

5. The Ethernet Traffic Generator and the OLT Emulator will be used to report/capture any upstream packets.
6. The Ethernet traffic generator will be configured to generate and transmit an upstream IGMPv1 membership report/group join message into the U-interface.

Test Procedure

1. Select random value for SVID1 between 1 and 4094. The VID shall be used as the VID of the S-Tag noted in the above configuration.
2. Cause the OLT Emulator to send the configured OMCI message sequence to provision the ONU.
3. Enable any frame capture mechanism on the OLT Emulator.
4. Cause the Ethernet traffic generator to transmit the upstream IGMPv1 membership report message into the ONU U-interface.
5. Verify the OLT Emulator does not receive the IGMPv1 upstream message.

OMCI Procedure Details

Refer to clause 4.3.

Pass/Fail Criteria

The test passes if the following are true, otherwise the test fails:

1. During ONU provisioning, each OMCI response message indicates success for the associated create or set command.
2. The uploaded ONU MIB must be consistent with the MIB held in the OLT Emulator
3. The upstream IGMPv1 message is not received by the Ethernet Traffic Generator and the OLT Emulator (it is silently discarded by the ONU).

Remarks

- None.

6.3.4 Test Case Reserved For Future Use

6.3.5 Marking Upstream IGMP Messages with Ethernet P-Bits

Test Name

Marking Upstream IGMP Messages with Ethernet P-Bits

Test Definition Number

ONU.6.3.5

Reference Document

BBF TR-156 [20]

ITU-T G.988 [6][7][8]

Test Type

Conformance

Test Requirement Type

Mandatory

Unit Under Test

ONU

Requirement Description

BBF TR-156:

- **R-94** The ONU MUST support marking, in the upstream direction, user-initiated IGMP messages with Ethernet P-bits

Test Objective

Verify that the ONU supports marking, in the upstream direction, of user-initiated IGMP messages with Ethernet P-bits

Test Configuration

1. OLT Emulator and ONU under test are powered and connected to ODN
2. ONU under test has been activated by the OLT Emulator, has been ranged, and a GEM port for OMCI has been created as a result of ONU-ID assignment.
3. The following Multicast group definition is applied at the OLT Emulator and transmitted by the OLT to the ONU under test using the Manage Entity "MULTICAST OPERATION PROFILE" (attribute: dynamic access control list table).

IPTV Channel (Group)	1
IP Multicast Group	IP_G1
MAC Multicast Group	MAC_G1

Multicast Server (Source)	1
Multicast Server IP Address	IP_S1
Multicast Server MAC Address	MAC_S1

- The ONU under test is configured to add an S-Tag to upstream untagged traffic

Test Procedure

- Select distinct random values for the multicast address MAC1 and unicast addresses MAC2
- Select distinct random values for the multicast address IP_G1 and unicast address IP_S1
- Use the OLT Emulator to provision the ONU under test (via defined OMCI messages below) to support one N:1 VLAN with one user traffic class, requiring 1 bidirectional unicast GEM port (Alloc-ID, T-CONT, Port-ID).
- Enable any frame monitoring/capture mechanisms on the OLT Emulator.
- Use the Ethernet Traffic Generator/Analyzer at the U-interface to send IGMP messages to join channel 1
- Use the Ethernet Traffic Generator/Analyzer at the U-interface to send IGMP Leave messages for channel 1

OMCI Procedure Details

Refer to clause 4.3.

Pass/Fail Criteria

The test passes if the following are true, otherwise the test fails:

- Each OMCI response message must indicate success for the associated create or set command.
- The uploaded ONU MIB must be consistent with the MIB held in the OLT Emulator
- Use the Ethernet Traffic Generator and the OLT Emulator to verify that all the IGMP Join and Leave messages received at the S/R-interface are S-tagged with a VID equal to SVID1 and S-Tag P-bits equal to SPbit1

Remarks

- None.

6.3.6 IGMP controlled Multicast

Test Name

IGMP controlled Multicast

Test Definition ID

ONU.6.3.6

Reference Document

BBF TR-156 [20]

ITU-T G.988 [6][7][8]

Test Type

Conformance

Test Requirement Type

Mandatory

Unit Under Test

ONU

Requirement Description**BBF TR-156:**

- **R-74** The G-PON network MUST be able to forward all multicast VLAN using a single downstream multicast GEM port
- **R-79** The G-PON network MUST use a bidirectional GEM port for upstream IGMP messages. This GEM port can be shared by other VLANs from the same U-interface that share the same TC

Test Objective

The purpose of this test is to verify that the ONU is able to receive all multicast-VLAN traffic using a single downstream multicast GEM port and IGMP messages use a bidirectional GEM port. This GEM port can be shared by other VLANs from the same U-interface that share the same TC

Test Configuration

1. ONU under test and OLT Emulator are powered and connected to ODN
2. ONU under test has been activated by the OLT Emulator, has been ranged, and a GEM port for OMCI has been created as a result of ONU-ID assignment.
3. A single U-interface is used
4. The Ethernet traffic generator connected to the OLT Emulator generates multicast Ethernet frames.

Multicast flow	Multicast IP source address	Multicast group IP destination address	Multicast MAC group address	VID	P-bit
Ch1	IP-S1	IP-G1	MAC-G1	VID1	Pbit1
Ch2	IP-S2	IP-G2	MAC-G2	VID2	Pbit1

5. The Ethernet traffic generator connected to the OLT Emulator generates unicast Ethernet frames

unicast destination MAC address	unicast Source MAC address	VID	P-bit
MAC-U1	MAC-V1	VID3	Pbit1

6. The Ethernet Traffic Generator connected to the U-interface generates unicast Ethernet frames

unicast destination MAC address	unicast Source MAC address	VID	P-bit
MAC-V1	MAC-U1	VID3	Pbit1

7. The Ethernet Traffic Generator connected to the U-interface is configured as follows. The IP and MAC addresses will be used to send IGMP V2 messages

Source IP address	Source MAC address	Multicast IP group address	VID	P-bit
IP-U2	MAC-U2	IP-G1	VID1	Pbit1

8. The Ethernet Traffic Generator connected to the U-interface is configured as follow. The IP and MAC addresses will be used to send IGMP V3 messages

Source IP address	Source MAC address	Multicast IP group address	Multicast source IP address	VID	P-bit
0.0.0.0	MAC-U3	IP-G2	IP-S2	VID2	Pbit1

9. This table shows the bidirectional GEM port mapping (unicast flow, and IGMP messages)

U-interface			GEM Port	T-CONT	S/R-interface
User Port	TPID	P-bit value			P-bit
1	0x8100	Pbit1	GEM1	TCONT1	Pbit1

10. All the previous flows have the same Traffic Class

Test Procedure

1. Select distinct random values for multicast IP group addresses: IP-G1 and IP-G2
2. Use associate multicast MAC addresses: MAC-G1 and MAC-G2.
3. Select distinct random values for IP addresses : IP-S1, IP-S2 and IP-U2
4. Select distinct random values for MAC addresses: MAC-U1, MAC-V1, MAC-U2 and MAC-U3
5. Select a random value for VID1, VID2 and VID3 between 1 and 4094 VID1≠VID2≠VID3.
6. Select a random value for Pbit1
7. Via the OLT Emulator, create a bidirectional GEM port between the OLT Emulator and the ONU under test U-interface, for IGMP messages and unicast flows
8. Create a multicast GEM port between the OLT Emulator and the ONU under test for multicast Ethernet frames
9. Configure the OLT Emulator to forward all multicast-VLAN traffic using a single downstream multicast GEM port
10. Configure the OLT Emulator to forward all multicast traffic to the multicast GEM Port permanently
11. Via the OLT Emulator configure the ONU under test to allow all channels
12. Generate downstream multicast traffic defined in test configuration step 4.
13. At the U-interface send IGMP messages to join channel Ch1
14. At the U-interface send IGMP message to leave Channel Ch1 and send IGMP messages to join channel Ch2
15. At the V and U-interface generate unicast Ethernet flows

OMCI Procedure Details

Refer to clause 4.3.

Pass/Fail Criteria

The test passes if the following are true, otherwise the test fails:

1. Each OMCI response message must indicate success for the associated create or set command.
2. The uploaded ONU MIB must be consistent with the MIB held in the OLT Emulator
3. The ONU is able to receive all multicast-VLAN traffic using a single downstream multicast GEM port
4. The ONU uses bidirectional GEM port to send and receive IGMP messages
5. The ONU can share bidirectional GEM port used for IGMP messages to transmit other VLANs with the same traffic class

Remarks

- None.

6.3.7 Multicast White List

Test Name

Multicast White List

Test Definition ID

ONU.6.3.7

Reference Document

BBF TR-156 [20]

ITU-T G.988 [6][7][8]

Test Type

Conformance

Test Requirement Type

Mandatory

Unit Under Test

ONU

Requirement Description**BBF TR-156:**

- **R-76** The ONU MUST allow the configuration of the IP multicast groups that are acceptable per user port based on:
 - Source address matching
 - Group address matching
 - VLAN membership
- **R-84** The ONU MUST support matching groups conveyed by IGMP messages on a user port to the list of groups (R-76) associated with this port. When there is no match, the copy of IGMP message directed toward the multicast-VLAN MUST be silently discarded. When there is a match, the IGMP message SHOULD be forwarded within a multicast-VLAN, and enter the IGMP snooping function.

Test Objective

The purpose of this test is to verify that the ONU is able to allow the configuration of the IP multicast groups that are acceptable per user port based on source address matching, group address matching and VLAN membership

Test Configuration

1. ONU under test and OLT Emulator are powered and connected to ODN
2. ONU under test has been activated by the OLT Emulator, has been ranged, and a GEM port for OMCI has been created as a result of ONU-ID assignment.

3. ONU and OLT MUST support IGMP V3
4. A single U-interface is used
5. A bidirectional GEM port between the ONU under test U-interface and the OLT Emulator has been created by OMCI, for IGMP messages
6. A downstream multicast GEM port between the ONU under test and the OLT Emulator has been created by OMCI, for multicast Ethernet frames.
7. The Ethernet Traffic Generator and the OLT Emulator generates multicast Ethernet frames as follows

Multicast flow	Multicast source IP address	Multicast IP group address	Multicast MAC group address	VID	p bit
Ch1	IP-S1	IP-G1	MAC-G1	CVID1	CPbit1
Ch2	IP-S2	IP-G2	MAC-G2	CVID1	CPbit1
Ch3	IP-S3	IP-G3	MAC-G3	CVID1	CPbit1
Ch4	IP-S3	IP-G4	MAC-G4	CVID1	CPbit1
Ch5	IP-S4	IP-G5	MAC-G5	CVID2	CPbit1
Ch6	IP-S5	IP-G5	MAC-G5	CVID3	CPbit1

Test Procedure

1. Select distinct random values for multicast IP group addresses: IP-G1, IP-G2, IP-G3, IP-G4 and IP-G5
2. Select distinct random values for IP addresses : IP-S1, IP-S2, IP-S3, IP-S4, and IP-S5
3. Select distinct random values for CVID1, CVID2, and CVID3.
4. Select a random value for CPbit1
5. Configure the OLT Emulator to forward all multicast traffic to the multicast GEM Port.
6. Via the OLT Emulator, configure the dynamic access list control table of the ONU (table index IND1)

Table Index	VLAN ID	Multicast source IP address	Multicast IP group address
IND1	CVID1	IP-S1	IP-G1
IND3	CVID1	IP-S3	IP-G3
IND5	CVID2	IP-S4	IP-G5

NB: 0.0.0.0 = no IP filtering according to ITU-T G.988[2]

7. Generate multicast traffic defined in test step 3 at the OLT Emulator
8. At the U-interface send IGMP messages to join channel Ch1

9. At the U-interface send IGMP message to leave Channel Ch1
10. At the U-interface send IGMP messages to join channel Ch2
11. At the U-interface send IGMP message to leave Channel Ch2
12. At the U-interface send IGMP messages to join channel Ch3
13. At the U-interface send IGMP message to leave Channel Ch3
14. At the U-interface send IGMP messages to join channel Ch4
15. At the U-interface send IGMP message to leave Channel Ch4
16. At the U-interface send IGMP messages to join channel Ch5
17. At the U-interface send IGMP message to leave Channel Ch5
18. At the U-interface send IGMP messages to join channel Ch6
19. At the U-interface send IGMP message to leave Channel Ch6

OMCI Procedure Details

Refer to clause 4.3.

Pass/Fail Criteria

The test passes if the following are true, otherwise the test fails:

1. Each OMCI response message must indicate success for the associated create or set command.
2. The uploaded ONU MIB must be consistent with the MIB held in the OLT Emulator
3. The ONU allows the configuration of the IP multicast groups that are acceptable per user port based on group address matching (step 7)
4. The U-interface receives the multicast flow channel Ch1 (step 8)
5. At the R/S-interface, the IGMP join message is not sent for the multicast flow channel Ch2 (step 10)
6. The U-interface does not receive the multicast flow channel Ch2 (step 10)
7. The U-interface receives the multicast flow channel Ch3 (step 12)
8. At the R/S-interface, the IGMP join message is not sent for the multicast flow channel Ch4 (step 14)
9. The U-interface does not receive the multicast flow channel Ch4 (step 14)
10. The U-interface receives the multicast flow channel Ch5 (step 16)
11. At the R/S-interface, the IGMP join message is not sent for the multicast flow channel Ch6 (step 18)
12. The U-interface does not receive the multicast flow channel Ch6 (step 18)

Remarks

- None.

6.3.8 IGMP rate limit

Test Name

IGMP rate limit

Test Definition ID

ONU.6.3.8

Reference Document

BBF TR-156 [20]

ITU-T G.988 [6][7][8]

Test Type

Conformance

Test Requirement Type

Mandatory

Unit Under Test

ONU

Requirement Description**BBF TR-156:**

- **R-87** The ONU MUST be able to rate-limit IGMP messages received from user ports on a multicast-VLAN.

Test Objective

The purpose of this test is to verify that the ONU is able to rate-limit IGMP messages received from user ports on a multicast-VLAN.

Test Configuration

1. ONU under test and OLT Emulator are powered and connected to ODN
2. ONU under test has been activated by the OLT Emulator, has been ranged, and a GEM port for OMCI has been created as a result of ONU-ID assignment.
3. A single U-interface is used
4. A bidirectional GEM port between the ONU under test U-interface and the OLT Emulator has been created by OMCI, for IGMP messages
5. A multicast GEM port between the ONU under test and the OLT Emulator has been created by OMCI, for multicast Ethernet frames.
6. The Ethernet Traffic Generator connected to the U-interface is configured to use the following IP and MAC addresses for sending IGMP messages

Source IP address	Source MAC address	Multicast IP group address	Multicast MAC group address	VID	P-bit
IP-U1	MAC-U1	IP-G1	MAC-G1	VID1	pbit1

Test Procedure

1. Select random value for IP address: IP-U1
2. Select random value for MAC address: MAC-U1
3. Select random value for multicast IP group address: IP-G1
4. Use associate multicast MAC group address: MAC-G1
5. Select a random value for VID1 between 1 and 4094.
6. Select a random value for pbit1
7. Via the OLT Emulator, configure the Upstream IGMP rate (IGMP message/second), select a random value (Value1) Value 1 must be between 10 and 100.
8. Generate upstream IGMP traffic defines in test condition 2 at the U-interface, with a IGMP rate below Value1
9. Generate upstream IGMP traffic defines in test condition 2 at the U-interface, with a IGMP rate above Value1
10. Via the G-PON analyser, verify that IGMP messages are rate-limited at the ONU

OMCI Procedure Details

Refer to clause 4.3.

Pass/Fail Criteria

The test passes if the following are true, otherwise the test fails:

1. Each OMCI response message must indicate success for the associated create or set command.
2. The uploaded ONU MIB must be consistent with the MIB held in the OLT Emulator
3. The upstream IGMP messages are rate-limited at the ONU
4. The upstream IGMP traffic in excess of this limit is silently discarded so that IGMP messages are forwarded at the rate define by value1

Remarks

- None.

6.3.9 IGMP immediate leave

Test Name

IGMP immediate leave

Test Definition ID

ONU.6.3.9

Reference Document

BBF TR-156 [20]

ITU-T G.988 [6][7][8]

Test Type

Conformance

Test Requirement Type

Mandatory

Unit Under Test

ONU

Requirement Description**BBF TR-156:**

- **R-91** The ONU MUST support IGMP immediate leave as part of the IGMP transparent snooping.

Test Objective

The purpose of this test is to verify that the ONU is able to support IGMP immediate leave as part of the IGMP transparent snooping.

Test Configuration

1. ONU under test and OLT Emulator are powered and connected to ODN
2. ONU under test has been activated by the OLT Emulator, has been ranged, and a GEM port for OMCI has been created as a result of ONU-ID assignment.
3. A single U-interface is used
4. A bidirectional GEM port between the ONU under test U-interface and the OLT Emulator has been created by OMCI, for IGMP messages
5. A multicast GEM port between the ONU under test and the OLT Emulator has been created by OMCI, for multicast Ethernet frames.
6. The Ethernet Traffic Generator and the OLT Emulator generates downstream multicast Ethernet frames:

Channel	Multicast source IP address	Multicast IP group address	Multicast MAC group address	VID	P-bit
Ch1	IP-S1	IP-G1	MAC-G1	VID1	Pbit1

- The Ethernet frames analyser is connected between ONU and the Ethernet traffic Generator

Test Procedure

- Select distinct random values for multicast IP group addresses: IP-G1
- Use associate multicast MAC address: MAC-G1
- Select random value for IP addresses: IP-S1
- Select random value for MAC addresses: MAC-S1
- Select a random value for VID1 between 1 and 4094
- Select a random value for pbit1
- Configure the OLT Emulator to forward all multicast traffic to the multicast GEM Port permanently
- Via the OLT Emulator, configure the dynamic access list control table at the ONU (table index IND1)

Table Index	VLAN ID	Multicast Source IP address	Multicast IP group address
IND1	VID1	0.0.0.0	IP-G1

- Via the OLT Emulator, configure the Immediate leave function at the ONU
- Generate multicast traffic defines in test condition 3 at the V-interface
- At the U-interface send IGMP messages to join channel Ch1
- At the U-interface send IGMP message to leave Channel Ch1
- Via Ethernet frames analyser, verify that Ch1 is immediately stopped when the ONU receives a leave IGMP message

OMCI Procedure Details

Refer to clause 4.3.

Pass/Fail Criteria

The test passes if the following are true, otherwise the test fails

- Each OMCI response message must indicate success for the associated create or set command.
- The uploaded ONU MIB must be consistent with the MIB held in the OLT Emulator
- The ONU support IGMP immediate leave as part of the IGMP transparent snooping (step 9)
- The U-interface receives the multicast flow with IP address IP-G1 (step 11)

5. Ch1 is immediately stopped when the ONU receives a leave IGMP message (no wait for expiry of any IGMP Query timer) (step 12)

Remarks

- None.

6.3.10 Maximum number of multicast flows

Test Name

Maximum number of multicast flows

Test Definition ID

ONU.6.3.10

Reference Document

BBF TR-156 [20]

ITU-T G.988 [6][7][8]

Test Type

Conformance

Test Requirement Type

Mandatory

Unit Under Test

ONU

Requirement Description

BBF TR-156:

R-97 The ONU MUST be able to configure per U-interface the maximum number of simultaneous multicast groups allowed.

Test Objective

The purpose of this test is to verify that the ONU is able to configure per U-interface the maximum number of simultaneous multicast groups allowed.

Test Configuration

1. ONU under test and OLT Emulator are powered and connected to ODN
2. ONU under test has been activated by the OLT Emulator, has been ranged, and a GEM port for OMCI has been created as a result of ONU-ID assignment.
3. A single U-interface is used
4. A bidirectional GEM port between the ONU under test U-interface and the OLT Emulator has been created by OMCI, for IGMP messages
5. A multicast GEM port between the ONU under test and the OLT Emulator has been created by OMCI, for multicast Ethernet frames.
6. The Ethernet Traffic Generator and the OLT Emulator generates downstream multicast Ethernet frames

Channel	Multicast source IP address	Multicast IP group address	Multicast MAC group address	VID	P-bit
---------	-----------------------------	----------------------------	-----------------------------	-----	-------

Ch1	IP-S1	IP-G1	MAC-G1	VID1	Pbit1
Ch2	IP-S1	IP-G2	MAC-G2	VID1	Pbit1
Ch3	IP-S1	IP-G3	MAC-G3	VID1	Pbit1

Test Procedure

1. Select distinct random values for multicast IP group addresses: IP-G1, IP-G2 and IP-G3
2. Use associate multicast MAC addresses: MAC-G1, MAC-G2 and MAC-G3
3. Select a random value for VID1 between 1 and 4094
4. Select a random value for pbit1
5. Configure the OLT Emulator to forward all multicast traffic to the multicast GEM Port permanently
6. Via the OLT Emulator, configure the dynamic access list control table at the ONU (table index IND1)

Table Index	VLAN ID	Multicast source IP address	Multicast IP group address
IND1	VID1	0.0.0.0	IP-G1
IND2	VID1	0.0.0.0	IP-G2
IND3	VID1	0.0.0.0	IP-G3

7. Via the OLT Emulator, configure the max simultaneous groups (value=2) at the ONU
8. Generate multicast traffic defines in test condition 3 at the V-interface
9. At the U-interface send IGMP messages to join channel Ch1
10. At the U-interface send IGMP messages to join channel Ch2
11. At the U-interface send IGMP messages to join channel Ch3
12. At the U-interface send IGMP messages to leave channel Ch2.
13. At the U-interface send IGMP messages to join channel Ch3 again.

OMCI Procedure Details

Refer to clause 4.3.

Pass/Fail Criteria

The test passes if the following are true, otherwise the test fails:

1. Each OMCI response message must indicate success for the associated create or set command.
2. The uploaded ONU MIB must be consistent with the MIB held in the OLT Emulator
3. The ONU is able to configure per U-interface the maximum number of simultaneous multicast groups allowed (step 7)

4. The U-interface receives simultaneously two multicast flows (step 9 and 10)
5. The U-interface does not receive the third multicast flow (step 11)
6. The U-interface receives simultaneously only one multicast flows, only Ch1 (step 12).
7. The U-interface receives simultaneously two multicast flows, Ch1 and Ch3. (step13).

Remarks

- None.

6.3.11 IGMP transparent Snooping

Test Name

IGMP transparent Snooping

Test Definition Number

ONU.6.3.11

Reference Document

BBF TR-156 [20]

ITU-T G.988 [6][7][8]

Test Type

Conformance

Test Requirement Type

Mandatory

Unit Under Test

ONU

Requirement Description**TR-156:**

- **R-88** The ONU and OLT MUST support an IGMP v3 (as per RFC 3376) transparent snooping function.
- **R-89** The ONU and OLT IGMP v3 transparent snooping function MUST support the capability to snoop the multicast source IP address and destination IP group address in IGMP messages and to set the corresponding MAC group address filters as specified in R-90.
- **R-90** The ONU and OLT IGMP v3 transparent snooping function MUST be able to dynamically create and delete MAC-level Group Filter entries, enabling in turn, selective multicast forwarding from network-facing VLANs to user-facing ports.

Test Objective

Verify the ONU supports the IGMP transparent snooping function and this functionality can be enabled for a multicast VLAN. Note, this test case does not cover the second MUST within R-88 and has been intentionally removed from the above requirements.

Test Configuration

1. ONU is powered and connected to ODN
2. ONU has been activated by the OLT Emulator, has been ranged, and a GEM port for OMCI has been created as a result of ONU-ID assignment.
3. The OLT Emulator has instructed the ONU to reset its MIB to factory default values.

4. ONU has successfully completed test cases in section 6.1.
5. The OLT Emulator should configure the ONU to support the following configuration:
 - One multicast VLANs, VID1
 - Enable IGMP transparent snooping on VLAN VID1
 - One bi-directional GEM port
 - One multicast GEM port
 - Singled-tagged U-interface, with no translation of VID values between the R/S and U-interfaces.
 - No restrictions for IGMP dynamic access (all flows are allowed)
6. The Ethernet Traffic Generator and the OLT Emulator will be configured to generate the following downstream, multicast flows. All flows should use the same multicast GEM port.

Flow	DST MAC Addr.	SRC MAC Addr.	DST IP Addr.	SRC IP Addr.	VID	TPID	P-bits
A	MAC-G1	MAC-S1	IP-G1	IP-S1	SVID1	0x8100	Any
B	MAC-G2	MAC-S2	IP-G2	IP-S2	SVID1	0x8100	Any
C	MAC-G3	MAC-S3	IP-G3	IP-S3	SVID1	0x8100	Any
D	MAC-G4	MAC-S4	IP-G4	IP-S4	SVID1	0x8100	Any

7. The Ethernet Traffic Generator should be configured to transmit the following upstream IGMP join/leave messages for each of the above multicast groups using the following parameters:

Flow	SRC MAC Addr.	SRC IP Addr.	VID	TPID	P-bits
E	MAC-S7	IP-S7	SVID1	0x8100	Any

Test Procedure

1. Select distinct random values for SVID1 between 1 and 4094.
2. Select distinct random values for MAC-S1 through MAC-S7, which are unicast MAC addresses
3. Select distinct random values for IP addresses IP-S1 through IP-S4 that are unicast IP addresses.
4. Select distinct random values for IP-G1 through IP-G4 that are multicast addresses and are not in the 224.0.0.0/24 range and generate the corresponding MAC destination addresses.
5. Configure the OLT Emulator to use the OMCI message sequence below to provision the ONU to support the configuration described above.
6. Enable any frame capture mechanisms on the Ethernet traffic generator.

7. Cause the Ethernet Traffic Generator and the OLT Emulator to continuously transmit the downstream, multicast flows described above.
8. Cause the Ethernet Traffic Generator at the U-interface to send an IGMP join request for flow A.
9. Cause the Ethernet Traffic at the U-interface Generator to send an IGMP join request for flow B.
10. Cause the Ethernet Traffic at the U-interface Generator to send an IGMP join request for flow C.

OMCI Procedure Details

Refer to clause 4.3.

Pass/Fail Criteria

The test passes if the following are true, otherwise the test fails:

1. Each OMCI response message must indicate success for the associated create or set command.
2. The uploaded ONU MIB must be consistent with the MIB held in the OLT Emulator
3. After step 7, the Ethernet Traffic Generator must not receive any Ethernet frames from multicast flows A through D.
4. After step 8, the Ethernet Traffic Generator must receive downstream, multicast flow A, as S-tagged Ethernet frames, with VID1.
5. After step 9, the Ethernet Traffic Generator must receive downstream, multicast flow B, as S-tagged Ethernet frames, with VID1.
6. After step 10, the Ethernet Traffic Generator must receive downstream, multicast flow C, as S-tagged Ethernet frames, with VID1.
7. After step 10, the Ethernet Traffic Generator not must receive any Ethernet frames from multicast flow D.

Remarks

- None.

6.3.12 Multicast VLAN membership based on user ports (Multiple User ports)

Test Name

Multicast VLAN membership based on user ports (Multiple User ports)

Test Definition ID

ONU.6.3.12

Reference Document

BBF TR-156 [20] Section 5.3.2

ITU-T G.988 [6][7][8]

Test Type

Conformance

Test Requirement Type

Conditional Mandatory (ONU with multiple user ports)

Unit Under Test

ONU

Requirement Description**BBF TR-156:**

- **R-96** The ONU MUST support configuring which user ports are members of a given multicast-VLAN

Test Objective

The purpose of this test is to verify that the support configuring which user ports are members of a given multicast-VLAN

Test Configuration

1. ONU under test and OLT Emulator are powered and connected to ODN
2. ONU under test has been activated by the OLT Emulator, has been ranged, and a GEM port for OMCI has been created by PLOAM.
3. Multiple U interfaces are used
4. The Ethernet Traffic Generator connected to the OLT Emulator generates multicast Ethernet frames.

Multicast flow	Multicast IP source address	Multicast group IP destination address	Multicast MAC group address	VID	P-bit
Ch1	IP-S1	IP-G1	MAC-G1	VID1	Pbit1
Ch2	IP-S2	IP-G2	MAC-G2	VID2	Pbit2

5. The Ethernet Traffic Generator connected to the U interface (user port 1) is configured as follow. The IP and MAC addresses will be used to send IGMP V2 messages

Source IP address	Source MAC address	Multicast IP group address	VID	P-bit
IP-U1	MAC-U1	IP-G1	VID1	Pbit1

6. The Ethernet Traffic Generator connected to the U interface (user port 2) is configured as follow. The IP and MAC addresses will be used to send IGMP V2 messages

Source IP address	Source MAC address	Multicast IP group address	VID	P-bit
IP-U2	MAC-U2	IP-G2	VID2	Pbit2

7. User port Multicast VLAN association at the ONU

User port	Multicast VLAN members
1	VID1
2	VID2

Test Procedure

1. Select distinct random values for multicast IP group addresses: IP-G1 and IP-G2
2. Use associate multicast MAC addresses: MAC-G1 and MAC-G2.
3. Select distinct random values for IP addresses : IP-S1, IP-S2, IP-U1 and IP-U2
4. Select distinct random values for MAC addresses: MAC-U1, MAC-U2
5. Select a random value for VID1, VID2 between 1 and 4094 VID1≠VID2.
6. Select a random value for pbit1 and pbit2
7. Via the OLT Emulator, create a bidirectional GEM port per U interface between the OLT Emulator and the ONU under test. This GEM ports will be used for IGMP messages
8. Create a multicast GEM port between the OLT Emulator and the ONU under test for multicast Ethernet frames

9. Configure the OLT Emulator to forward all multicast-VLAN traffic (VID1 and VID2) using a single downstream multicast GEM port
10. Via the OLT Emulator configure the ONU under test to allow multicast flow
 - a. For user port 1

Table Index	VLAN ID	Multicast source IP address	Multicast IP group address
IND1	VID1	IP-S1	IP-G1

- b. For user port 2

Table Index	VLAN ID	Multicast source IP address	Multicast IP group address
IND1	VID2	IP-S2	IP-G2

11. Generate multicast traffic defines in test configuration 4 at the OLT Emulator
12. At the U interface (user port 1) send IGMP messages to join channel Ch1
13. At the U interface (user port 1) send IGMP messages to join channel Ch2
14. At the U interface (user port 2) send IGMP message to join Channel Ch1
15. At the U interface (user port 2) send IGMP message to join Channel Ch2

OMCI Procedure Details

Refer to clause 4.3.

Pass/Fail Criteria

The test is "pass" if:

1. Each OMCI response message must indicate success for the associated create or set command.
2. The uploaded ONU MIB must be consistent with the MIB held in the OLT Emulator
3. The ONU is able to configure multicast members by user port (at step 11)
4. At step 12 User port 1 receives only Ch 1 and user port 2 doesn't receive any channel
5. At step 13 User port 1 receives only Ch 1 and user port 2 doesn't receive any channel
6. At step 14 User port 1 receives only Ch 1 and user port 2 doesn't receive any channel
7. At step 15, User port 1 receives only Ch 1 and user port 2 only Ch2

Remarks

- None.

6.3.13 IGMP transparent Snooping (Multiple User ports)

Test Name

IGMP transparent Snooping (Multiple User ports)

Test Definition Number

ONU.6.3.13

Reference Document

BBF TR-156 [20]

Test Type

Conformance

Test Requirement Type

Conditionally Mandatory (if ONT has multiple user ports)

Unit Under Test

ONU

Requirement Description**TR-156:**

- **R-88:** The ONU and OLT MUST support an IGMP v3 (as per RFC 3376) transparent snooping function.
- **R-89:** The ONU and OLT IGMP v3 transparent snooping function MUST support the capability to snoop the multicast source IP address and destination IP group address in IGMP messages and to set the corresponding MAC group address filters as specified in R-90.
- **R-90:** The ONU and OLT IGMP v3 transparent snooping function MUST be able to dynamically create and delete MAC-level Group Filter entries, enabling in turn, selective multicast forwarding from network-facing VLANs to user-facing ports.

Test Objective

Verify the ONU supports the IGMP transparent snooping function and this functionality can be enabled for a multicast VLAN for ONU with multiple U Interfaces. Note, this test case does not cover the second MUST within R-88 and has been intentionally removed from the above requirements.

Test Configuration

- ONU is powered and connected to ODN
- ONU has been activated by the OLT Emulator, has been ranged, and a GEM port for OMCI has been created by PLOAM.
- The OLT Emulator has instructed the ONU to reset its MIB to factory default values.
- The OLT Emulator should configure the ONU to support the following configuration:

- One multicast VLAN, VID1
- Enable IGMP transparent snooping on VLAN VID1
- One bi-directional GEM port per U-interface
- One multicast GEM port
- Symmetric user port tagging rules

User port	U interface Q-Tag	R/S interface S-Tag
1	None	SVID1
2	None	SVID1

- All U-interfaces are member of VID1
- No restrictions for IGMP dynamic access (all flows are allowed)
- The Ethernet Traffic Generator and the OLT Emulator will be configured to generate the following downstream, multicast flows. All flows should use the same multicast GEM port.

Flow	DST MAC Addr.	SRC MAC Addr.	DST IP Addr.	SRC IP Addr.	VID	TPID	P-bits
A	MAC-G1	MAC-S1	IP-G1	IP-S1	SVID1	0x88a8	Any
B	MAC-G2	MAC-S2	IP-G2	IP-S2	SVID1	0x88a8	Any
C	MAC-G3	MAC-S3	IP-G3	IP-S3	SVID1	0x88a8	Any
D	MAC-G3	MAC-S4	IP-G4	IP-S4	SVID1	0x88a8	Any

- The Ethernet Traffic Generator should be configure to transmit the following upstream IGMP join/leave messages for each of the above multicast groups using the following parameters:

Flow	User port	SRC MAC Addr.	SRC IP Addr.	VID	TPID	P-bits
E	1	MAC-U1	IP-U1	None	None	None
F	2	MAC-U2	IP-U2	None	None	None

Test Procedure

1. Select distinct random values for VID1 between 1 and 4094.

2. Select distinct random values for MAC-S1, MAC-S2, MAC-S3, MAC-S4, MAC-U1 and MAC-U2, which are unicast MAC addresses
3. Select distinct random values for IP addresses IP-S1 IP-S2, IP-S3, IP-S4, IP-U1 and IP-U2 that are unicast IP addresses.
4. Select distinct random values for IP-G1 through IP-G4 that are multicast addresses and are not in the 224.0.0.0/24 range and generate the corresponding MAC destination addresses.
5. Configure the OLT Emulator to use the OMCI message sequence describe in Annex B to provision the ONU to support the configuration described above.
6. Enable any frame capture mechanisms on the Ethernet traffic generator.
7. Cause the Ethernet Traffic Generator and the OLT Emulator to continuously transmit the downstream, multicast flows described above.
8. Cause the Ethernet Traffic Generator to send an IGMP join request for flow A via user port 1.
9. Cause the Ethernet Traffic Generator to send an IGMP join request for flow B via user port 2
10. Cause the Ethernet Traffic Generator to send an IGMP join request for flow C via user port 1.

OMCI Procedure Details

Refer to clause 4.3.

Pass/Fail Criteria

1. Each OMCI response message must indicate success for the associated create or set command.
2. The uploaded ONU MIB must be consistent with the MIB held in the OLT Emulator
3. After step 7, User port 1 and User port 2 must not receive any Ethernet frames from multicast flows A through D.
4. After step 8, User port 1 must only receive downstream multicast flow A, as untagged frames. User port 2 must not receive any multicast flows.
5. After step 9, User port 1 must only receive downstream multicast flow A, as untagged frames. User port 2 must only receive downstream multicast flow B untagged frames.
6. After step 10, User port 1 must only receive downstream multicast flow A and C, as untagged frames. User port 2 must only receive downstream multicast flow B as untagged frames.

Remarks

- None.

6.3.14 IGMP Transparent forwarding

Test Name

IGMP Transparent forwarding

Test Definition ID

ONU. 6.3.14

Reference Document

BBF TR-156 [20]

ITU-T G.988 [6][7][8]

Test Type

Conformance

Test Requirement Type

Mandatory

Unit Under Test

ONU

Requirement Description**BBF TR-156:**

- **R-10** The ONU MUST support adding an S-Tag to upstream untagged traffic received from the U-interface.
- **R-20** The ONU MUST support adding a C-Tag or S-Tag to upstream untagged traffic.
- **R-34** The ONU MUST support adding an S-Tag in the upstream direction for Q-tagged, untagged, and priority-tagged frames.
- **R-82** The ONU and OLT MUST support the identification and processing of upstream IGMP messages. When this function is disabled on a port and/or VLAN, these messages are transparently forwarded.

Note: Only the second sentence in R-82 is verified by this test.

Test Objective

Verify the ONU supports the IGMP transparent forwarding function on a single U-interface configured to pass untagged traffic across the U-interface. This test verifies both the OMCI configuration responses and support of active user traffic. The VLAN S-Tag is added to upstream traffic by the ONU before crossing the R/S-interface. Note that only the default behaviour described in the second half of R-82 is verified in this test.

Test Configuration

1. ONU is powered and connected to ODN

2. ONU has been activated by the OLT Emulator, has been ranged, and a GEM port for OMCI has been created as a result of ONU-ID assignment.
3. The OLT Emulator has instructed the ONU to reset its MIB to factory default values.
4. The Ethernet Traffic Generator should be configured to transmit Ethernet frames upstream with the following parameters:

Upstream Direction																								
Traffic Stream	U Interface												R/S Interface											
	UNI	MAC DA	MAC SA	Outer VLAN Tag				Inner VLAN Tag				Ethertype	IP DA	IP SA	Outer VLAN Tag				Inner VLAN Tag				GEM	T-CONT
	Port #	Value	Value	TPID	Pbits	DEI	VID	TPID	Pbits	CFI or DEI	VID	Value	Value	Value	TPID	Pbits	DEI	VID	TPID	Pbits	CFI or DEI	VID	Port #	Number
A	1	MAC_MC1	MAC2	n/a	n/a	n/a	n/a	n/a	n/a	n/a	n/a	0x0800	IP_MC1	IP1	n/a	n/a	n/a	n/a	0x88A8	0	x	SVID1	GEM1	TCONT1

5. Only 1 user traffic class should be configured on the ONU (via defined OMCI messages below), requiring 1 GEM port (Alloc-ID, T-CONT, Port-ID).

Test Procedure

1. Select a random value for SVID1 between 1 and 4094.
2. Select unicast values for MAC2, which are not already in use by the ONU or other connected devices.
3. Select a multicast address for MAC_MC1
4. Configure the OLT Emulator to use the message sequence below to provision the ONU to support:
 - a. A single untagged U-interface
 - b. Addition/removal of the S-Tag in the upstream/downstream directions, respectively
5. Cause the OLT Emulator to request the ONU to upload its current MIB.
6. Enable any frame capture mechanisms on the OLT Emulator.
7. Cause the Ethernet Traffic Generator to transmit upstream frame(s) described in Frame-Set, A. A frame must contain IGMP join reports.

OMCI Procedure Details

Refer to clause 4.3.

Pass/Fail Criteria

The test passes if the following are true, otherwise the test fails:

1. Each OMCI response message shall indicate success for the associated create or set command.
2. The uploaded ONU MIB shall be consistent with the MIB held in the OLT Emulator
3. All upstream frame(s) from Frame-Set A shall have been received as S-tagged frame(s) with the VID equal to SVID1 and TPID=0x88A8.

Remarks

- No MAC filtering should be enabled on the ONU during these tests, or it should be configured to allow the test user traffic to pass through the ONU.

6.3.15 Maximum Multicast Bandwidth

Test Name

Maximum Multicast Bandwidth

Test Definition Number

ONU.6.3.15

Reference Document

BBF TR-280 [23]

ITU-T G.988 [6][7][8]

Test Type

Conformance

Test Requirement Type

Mandatory

Unit Under Test

ONU

Requirement Description**BBF TR-280**

- **R-19** The OLT and the ONU MUST be capable of supporting a maximum multicast bandwidth per U interface
- **R-20** The maximum multicast bandwidth must be configurable as defined in G.988 [8]
- **R-55** The ONU MUST support the following attributes of the Multicast Subscriber monitor ME defined in G.988 [8]:
 - Current multicast bandwidth
 - Join messages counter
 - Bandwidth exceeded counter

Test Objective

The purpose of this test is to verify that the ONU is able to configure per U-interface the maximum Multicast bandwidth.

Test Configuration

1. OLT Emulator and ONU under test are powered and connected to ODN
2. ONU under test has been activated by the OLT Emulator, has been ranged, and a GEM port for OMCI has been created as a result of ONU-ID assignment.
3. A single U-interface is used
4. A bidirectional GEM port, between the ONU under test U-interface and the OLT Emulator, has been created by OMCI, for IGMP messages
5. A multicast GEM port, between the OLT Emulator and the ONU under test, has been created by OMCI, for multicast Ethernet frames.
6. The Traffic Generator should be configured to transmit the downstream multicast Ethernet frames as defined below:

Channel	Multicast source IP address	Multicast IP group address	Multicast MAC group address	VID	P-bit	Bandwidth kbit/s	Bandwidth kbytes/s
Ch1	IP-S1	IP-G1	MAC-G1	SVID1	SPbit1	2048	256
Ch2	IP-S1	IP-G2	MAC-G2	SVID1	SPbit1	2048	256
Ch3	IP-S1	IP-G3	MAC-G3	SVID1	SPbit1	3072	384

Test Procedure

1. Select distinct random values for multicast IP group addresses: IP-G1, IP-G2 and IP-G3
2. Use associate random multicast MAC addresses: MAC-G1, MAC-G2 and MAC-G3
3. Select a random value for SVID1 between 1 and 4094
4. Select a random value for SPbit1
5. Configure the OLT Emulator to forward all multicast traffic to the multicast GEM Port permanently
6. Via the OLT Emulator, configure the dynamic access list control table of the Multicast operation profile ME at the ONU (table index IND1)

Table Index	VLAN ID	Multicast source IP address	Multicast IP group address	Imputed Group Bandwidth bytes/s
IND1	SVID1	0.0.0.0	IP-G1	512 000
IND2	SVID1	0.0.0.0	IP-G2	512 000
IND3	SVID1	0.0.0.0	IP-G3	768 000

7. Via the OLT Emulator, configure the max multicast bandwidth (value=1 024 000) and the bandwidth enforcement attribute with the value true at the ONU
8. Via the OLT Emulator, create the Multicast Subscriber Monitor ME
9. Cause the Traffic Generator to transmit the multicast traffic defined in test configuration step 6 at the V-interface
10. At the U-interface send two IGMP messages to join channel Ch1
11. At the U-interface send two IGMP messages to join channel Ch2
12. At the U-interface send two IGMP messages to join channel Ch3
13. Report the “Current Multicast bandwidth”, “bandwidth exceeded counter” attributes of Multicast Subscriber Monitor ME
14. At the U-interface send two IGMP messages to leave channel Ch2.
15. At the U-interface send two IGMP messages to join channel Ch3 again
16. Report the “Current Multicast bandwidth”, “bandwidth exceeded counter” attributes of Multicast Subscriber Monitor ME
17. At the U-interface send two IGMP messages to leave channel Ch1
18. At the U-interface send two IGMP messages to join channel Ch3 again.
19. Report the “Current Multicast bandwidth”, “bandwidth exceeded counter” attributes of Multicast Subscriber Monitor ME

OMCI Procedure Details

Refer to clause 4.3.

Pass/Fail Criteria

The test passes if the following are true, otherwise the test fails:

1. Each OMCI response message must indicate success for the associated create or set command.
2. The uploaded ONU MIB must be consistent with the MIB held in the OLT Emulator.
3. The ONU is able to configure the “maximum multicast bandwidth” allowed at step 7.
4. The S/R interface receives Ch1 Join Message at step 10.
5. The U-interface receives only the multicast flow Ch1 at step 10.
6. The S/R interface receives Ch2 Join Message at step 11.
7. The U-interface receives only the two multicast flows Ch1 and Ch2 at step 11.

8. The U-interface receives only the two multicast flows Ch1 and Ch2 at step 12.
9. The reported "Current Multicast bandwidth" value is greater than zero, "bandwidth exceeded counter" is 2 at step 13.
10. The S/R interface receives Ch2 Leave Message at step 14.
11. The U-interface receives only the multicast flow Ch1 at step 14.
12. The U-interface receives only the multicast flow Ch1 at step 15.
13. The reported "Current Multicast bandwidth" value is greater than zero and "bandwidth exceeded counter" is 4 at step 16.
14. The S/R interface receives Ch1 Leave Message at step 17.
15. The S/R interface receives Ch3 Join Message at step 17 or 18.
16. The U-interface receives only the multicast flow Ch3 at step 18.
17. The reported "Current Multicast bandwidth" value is greater than zero and "bandwidth exceeded counter" is 4 at step 19.

Remarks

- None.

6.3.16 VID and P-bit Translation in Upstream and Downstream for IGMP/MLD and Multicast Packets

Test Name

VID and P-bit Translation in Upstream and Downstream for IGMP/MLD and Multicast Packets

Test Definition Number

ONU.6.3.16

Reference Document

BBF TR-280 [23]

ITU-T G.988 [6][7][8]

Test Type

Conformance

Test Requirement Type

Mandatory

Unit Under Test

ONU

Requirement Description**BBF TR-280**

- **R-16** The ONU MUST support all combinations of VID and P-bit translation in the upstream direction for IGMP/MLD packets, and IGMP/MLD and multicast frames in the downstream direction
- **R-17** The ONU MUST support the following attributes of multicast TCI of Multicast Operations Profile ME:
 - Upstream IGMP TCI,
 - Upstream IGMP tag control
 - All code points defined in this attribute
 - Downstream IGMP and multicast TCI
 - all code points defined in these attribute

Test Objective

The purpose of this test is to verify that the ONU is able to configure and perform VID and P-bit translation in upstream and downstream for IGMP/MLD and Multicast packets.

Test Configuration

1. OLT Emulator and ONU under test are powered and connected to ODN
2. The ONU under test has been activated by the OLT Emulator, has been ranged, and a GEM port for OMCI has been created as a result of ONU-ID assignment.
3. A single U-interface is used
4. A bidirectional GEM port between the ONU under test U-interface and the OLT Emulator has been created by OMCI, for IGMP messages and unicast traffic.
5. A multicast GEM port between the ONU under test and the OLT Emulator has been created by OMCI, for multicast Ethernet frames.
6. The Traffic Generator should be configured to transmit the downstream multicast Ethernet frames with the following parameters:

Channel	Multicast source IP address	Multicast IP group address	Multicast MAC group address	VID	P-bit
Ch1	IP-S1	IP-G1	MAC-G1	CVID1	CPbit1
Ch2	IP-S2	IP-G2	MAC-G2	CVID1	CPbit1

7. The Traffic Generator should be configured to transmit the following upstream IGMP v2 messages

Source IP address	Source MAC address	Multicast IP group address	VID	P-bit
IP-U1	MAC3	IP-G1	CVID2	CPbit2

8. The Traffic generator should be configured to transmit the following upstream IGMP v3 messages

Source IP address	Source MAC address	Multicast IP group address	Multicast source IP address	VID	P-bit
0.0.0.0	MAC4	IP-G2	IP-S2	CVID2	CPbit2

9. The Traffic Generator should be configured to transmit unicast single-tagged Ethernet frames with the following parameters:

Upstream Direction																								
Traffic Stream	U Interface														R/S Interface									
	UNI	MAC DA	MAC SA	Outer VLAN Tag				Inner VLAN Tag				Ethertype	IP DA	IP SA	Outer VLAN Tag				Inner VLAN Tag				GEM	T-CONT
	Port #	Value	Value	TPID	Pbits	DEI	VID	TPID	Pbits	CFI or DEI	VID	Value	Value	Value	TPID	Pbits	DEI	VID	TPID	Pbits	CFI or DEI	VID	Port #	Number
A	1	MAC1	MAC2	n/a	n/a	n/a	n/a	0x8100	CPbit3	n/a	CVID3	x	x	x	n/a	n/a	n/a	n/a	0x8100	CPbit1	x	CVID1	GEM1	TCONT1

Downstream Direction																							
Traffic Stream	S/R Interface														U Interface								
	MAC DA	MAC SA	Outer VLAN Tag				Inner VLAN Tag				Ethertype	IP DA	IP SA	GEM	Outer VLAN Tag				Inner VLAN Tag				UNI
	Value	Value	TPID	Pbits	DEI	VID	TPID	Pbits	CFI or DEI	VID	Value	Value	Value	Port #	TPID	Pbits	DEI	VID	TPID	Pbits	CFI or DEI	VID	Port #
B	MAC2	MAC1	n/a	n/a	n/a	n/a	0x8100	CPbit1	x	CVID1	x	x	x	GEM1	n/a	n/a	n/a	n/a	0x8100	CPbit3	n/a	CVID3	1

10. The OLT Emulator configures the ONU to perform unicast VLAN translation as indicated in the traffic defined in test configuration step 9

Test Procedure

1. Select distinct random values for multicast IP group addresses: IP-G1, IP-G2
2. Use associated multicast MAC addresses: MAC-G1 and MAC-G2
3. Select distinct random values for IP addresses: IP-U1, IP-S1, IP-S2
4. Select distinct random values for MAC address: MAC 1, MAC2, MAC3, MAC4
5. Select distinct random values for CVID1, CVID2, CVID3 between 1 and 4094
6. Select distinct random values for CPbit1, CPbit2 and CPbit3
7. The OLT Emulator configures the ONU to replace tag in the upstream direction for IGMP/MLD flows with CVID1 and CPbit1
8. The OLT Emulator configures the ONU to replace tag in the downstream direction for IGMP/MLD and multicast flows with CVID2 and CPbit2
9. Via the OLT Emulator, configure the dynamic access list control table of Multicast Operation Profile ME at the ONU (table index IND1)

Table Index	VLAN ID	Multicast source IP address	Multicast IP group address
IND1	CVID1	0.0.0.0	IP-G1
IND2	CVID1	0.0.0.0	IP-G2

10. Configure the OLT Emulator to forward all multicast traffic to the multicast GEM Port permanently
11. Cause the Ethernet Traffic Generator to transmit unicast traffic as defined in test configuration step 9 .

12. Cause the Ethernet Traffic Generator to transmit multicast traffic as defined in test configuration step 6
13. At the U-interface, cause the Ethernet Traffic Generator to transmit IGMP messages to join channel Ch1 as defined in test configuration step 7
14. Cause the Ethernet Traffic Generator to send one IGMP global/general query message to the multicast GEM port with CVID1 and CPbit1 from IP-S1.
15. At the U-interface, cause the Ethernet Traffic Generator to transmit IGMP messages to join channel Ch1 as defined in test configuration step 7
16. Cause the Ethernet Traffic Generator to send one IGMP global/general query message to the unicast GEM port GEM1 with CVID1 and CPbit1 from IP-S1.
17. At the U-interface, cause the Ethernet Traffic Generator to transmit IGMP messages to join channel Ch1 as defined in test configuration step 7
18. At the U-interface, cause the Ethernet Traffic Generator to transmit IGMP messages to leave channel Ch1 as defined in test configuration step 7
19. At the U-interface, cause the Ethernet Traffic Generator to transmit IGMP messages to join channel Ch2 as defined in test configuration step 8
20. Cause the Ethernet Traffic Generator to send one IGMP global/general query message to the multicast GEM port with CVID1 and CPbit1 from IP-S2.
21. At the U-interface, cause the Ethernet Traffic Generator to transmit IGMP messages to join channel Ch2 as defined in test configuration step 8
22. Cause the Ethernet Traffic Generator to send one IGMP global/general query message to the unicast GEM port GEM1 with CVID1 and CPbit1 from IP-S2
23. At the U-interface, cause the Ethernet Traffic Generator to transmit IGMP messages to join channel Ch2 as defined in test configuration step 8
24. At the U-interface, cause the Ethernet Traffic Generator to transmit IGMP messages to leave channel Ch2 as defined in test configuration step 8

OMCI Procedure Details

Refer to clause 4.3.

Pass/Fail Criteria

The test passes if the following are true, otherwise the test fails:

1. Each OMCI response message must indicate success for the associated create or set command.
2. The uploaded ONU MIB must be consistent with the MIB held in the OLT Emulator
3. The U-interface receives unicast flow with CVID3 and CPbit3 at step 11
4. Upstream unicast packets are received by the Ethernet Traffic Generator and the OLT Emulator with CVID1 and CPbit1 at step 11
5. Upstream IGMP packets are received by the Ethernet Traffic Generator and the OLT Emulator with CVID1 and CPbit1 at step 13
6. The S/R interface receives Ch1 Join Message at step 13
7. The U-interface receives multicast flow Ch1 with CVID2 and CPbit2 at step 13

8. The U-interface receives one IGMP (General Query) message with CVID2 and CPbit2 at steps 14
9. The S/R interface receives Ch1 Join Message at step 15 with CVID1 and Cpbit1
10. The U-interface receives one IGMP (General Query) message with CVID2 and CPbit2 at steps 16
11. The S/R interface receives Ch1 Join Message at step 17 with CVID1 and Cpbit1
12. The S/R interface receives Ch1 Leave Message at step 18 with CVID1 and Cpbit1
13. Upstream IGMP packets are received by the Ethernet Traffic Generator and the OLT Emulator with CVID1 and CPbit1 at step 19
14. The S/R interface receives Ch2 Join Message at step 19
15. The U-interface receives multicast flow Ch2 with CVID2 and CPbit2 at step 19
16. The U-interface receives one IGMP (General Query) message with CVID2 and CPbit2 at step 20
17. The S/R interface receives Ch2 Join Message at step 21 with CVID1 and Cpbit1
18. The U-interface receives one IGMP (General Query) message with CVID2 and CPbit2 at step 22
19. The S/R interface receives Ch2 Join Message at step 23 with CVID1 and Cpbit1
20. The S/R interface receives Ch2 Leave Message at step 24 with CVID1 and Cpbit1

Remarks

- None.

6.3.17 Create and Remove Multicast Groups in the Dynamic Access Control List table

Test Name

Create and Remove Multicast Groups in the Dynamic Access Control List table

Test Definition Number

ONU.6.3.17

Reference Document

BBF TR-156 [20]

BBF TR-280 [23]

BBF TR-280 Amendment 1 [24]

ITU-T G.988 [6][7][8]

Test Type

Conformance

Test Requirement Type

Mandatory

Unit Under Test

ONU

Requirement Description**BBF TR-280 Amendment 1**

- **[R-75]** The ONU MUST support the deletion of an entry into the Dynamic Access Control List table in the Multicast Operation Profile ME without causing any reboot, or MIB reset.
- **[R-76]** The ONU MUST support the deletion of entries into the Dynamic Access Control List table in the Multicast Operation Profile ME without causing any packet loss on existing traffic flows from all the traffic classes and existing active Multicast Groups (as defined in TR-156, R-76).
- **[R-77]** The ONU MUST support the addition of an entry into the Dynamic Access Control List table in the Multicast Operation Profile ME without causing any reboot, or MIB reset.
- **[R-78]** The ONU MUST support the addition of entries into the Dynamic Access Control list table in the Multicast Operation Profile ME without causing any packet loss on existing traffic flows from all the traffic classes and existing active Multicast Groups (as defined in TR-156, R-76).

TR-156

- **[R-84]** The OLT and ONU MUST support matching groups conveyed by IGMP messages on a user port to the list of groups (R-76) associated with this port. When there is no match, the copy of the IGMP message directed toward the multicast-VLAN MUST be silently discarded. When there is a match, the upstream IGMP message SHOULD be forwarded by the OLT within a multicast-VLAN.

Note that in case R-84 is applied, then the behavior specified in R-88 does not apply.

Note: IGMP v3 report messages may carry membership information for multiple multicast groups. Therefore, a single IGMP report message may carry membership information on groups 'matching' a multicast VLAN as well as on groups 'not matching' a multicast VLAN.

Test Objective

Verify that the ONU is able to create and remove multicast group

Test Configuration

1. OLT Emulator and ONU are powered on and connected to ODN
2. The ONU under test has been activated by the OLT Emulator, has been ranged, and a GEM port for OMCI has been created as a result of ONU-ID assignment
3. A single U-interface is used
4. A bidirectional GEM port, between the ONU under test U-interface and the OLT Emulator, has been created by OMCI, for IGMP messages
5. Note: The IGMP version is IGMPv2
6. A multicast GEM port, between the ONU under test and the OLT Emulator, has been created by OMCI, for multicast Ethernet frames
7. The Traffic Generator should be configured to transmit the downstream multicast Ethernet frames as defined below:

Channel	Multicast source IP address	Multicast IP group address	Multicast MAC group address	VID	P-bit
Ch1	IP-S1	IP-G1	MAC-G1	SVID1	SPbit1
Ch2	IP-S1	IP-G2	MAC-G2	SVID1	SPbit1

Test Procedure

1. Select random value for IP addresses: IP-S1
2. Select distinct random values for multicast IP group addresses: IP-G1 and IP-G2
3. Use associated random multicast MAC addresses: MAC-G1 and MAC-G2
4. Select a random value for SVID1 between 1 and 4094
5. Select a random value for SPbit1 between 0 and 7

6. Configure the OLT Emulator to forward all multicast traffic to the multicast GEM Port permanently
7. Cause the OLT Emulator to configure the dynamic access list control table of Multicast Operations Profile ME at the ONU (table index IND1)

Table Index	VLAN ID	Multicast source IP address	Multicast IP group address
IND1	SVID1	0.0.0.0	IP-G1

8. At the U-interface send IGMP message to join channel Ch1
9. Cause the OLT Emulator to configure the dynamic access list control table of Multicast Operations Profile ME at the ONU (table index IND2)

Table Index	VLAN ID	Multicast source IP address	Multicast IP group address
IND2	SVID1	0.0.0.0	IP-G2

10. At the U-interface send IGMP message to join channel Ch2
11. At the U-interface send IGMP messages to leave channel Ch1 and Ch2
12. Cause the OLT Emulator to remove the entry at index IND1 from the dynamic access list control table of Multicast Operations Profile ME at the ONU

Table Index	VLAN ID	Multicast source IP address	Multicast IP group address
IND1	SVID1	0.0.0.0	IP-G1

13. At the U-interface send IGMP messages to join channel Ch1 and Ch2

OMCI Procedure Details

Refer to clause 4.3.

Pass/Fail Criteria

The test passes if the following are true, otherwise the test fails:

1. All OMCI commands have success responses
2. The U-interface does not receive the multicast flows Ch1 and Ch2 at steps 6 and 7
3. The S/R interface receives Ch1 Join Message at step 8
4. The U-interface receives the multicast flow Ch1 at steps 8 and 9
5. The U-interface does not receive the multicast flow Ch2 at steps 8 and 9
6. The S/R interface receives Ch2 Join Message at step 10

7. The U-interface receives the multicast flows Ch1 and Ch2 at step 10
8. The S/R interface receives Ch1 and Ch2 Leave Message at step 11
9. The U-interface does not receive the multicast flows Ch1 and Ch2 at steps 11 and 12
10. The S/R interface does not receive the Ch1 Join Message at step 13
11. The S/R interface receives the Ch2 Join Message at step 13
12. The U-interface does not receive the multicast flow Ch1 at step 13
13. The U-interface receives the multicast flow Ch2 at step 13

Remarks

- None.

6.3.18 Maximum Number of Dynamic Multicast Groups Modification

Test Name

Maximum Number of Dynamic Multicast Groups Modification

Test Definition Number

ONU.6.3.18

Reference Document

BBF TR-280 [23]

BBF TR-280 Amendment 1 [24]

ITU-T G.988 [6][7][8]

Test Type

Conformance

Test Requirement Type

Mandatory

Unit Under Test

ONU

Requirement Description

BBF TR-280 Amendment 1

- **R-79** The ONU MUST support the modification of the Maximum Simultaneous Groups in the Multicast Subscriber Config Info ME without causing any reboot, or MIB reset.
- **R-80** The ONU MUST support the modification of the Maximum Simultaneous Groups in the Multicast Subscriber Config Info ME without causing any packet loss on existing traffic flows from all the traffic classes and existing active Multicast Groups (as defined in TR-156, R-76).

Note: If the Maximum Simultaneous Groups value is decreased, no packet loss is expected on the existing active Multicast Groups until the Multicast Channel Subscriber leaves the channel. For example, at the beginning 4 channels are allowed and the Multicast Channel Subscriber receives 4 channels, then the Maximum Simultaneous Groups is reconfigured to 3. If the Multicast Channel Subscriber leaves a channel, then the associated Multicast Channel is stopped. If the Multicast Channel Subscriber wants to subsequently join a 4th channel, the ONU MUST deny joining the 4th channel because the Maximum Simultaneous Groups is already reached.

Test Objective

Verify that the ONU is able to modify the maximum number of dynamic multicast groups

Test Configuration

1. OLT Emulator and ONU are powered on and connected to ODN
2. The ONU under test has been activated by the OLT Emulator, has been ranged, and a GEM port for OMCI has been created as a result of ONU-ID assignment
3. A single U-interface is used
4. A bidirectional GEM port, between the ONU under test U-interface and the OLT Emulator, has been created by OMCI, for IGMP messages

Note: The IGMP version is IGMPv2

5. A multicast GEM port, between the ONU under test and the OLT Emulator, has been created by OMCI, for multicast Ethernet frames
6. The Traffic Generator should be configured to transmit the downstream multicast Ethernet frames as defined below:

Channel	Multicast source IP address	Multicast IP group address	Multicast MAC group address	VID	P-bit
Ch1	IP-S1	IP-G1	MAC-G1	SVID1	SPbit1
Ch2	IP-S1	IP-G2	MAC-G2	SVID1	SPbit1

Test Procedure

1. Select random value for IP addresses: IP-S1
2. Select distinct random values for multicast IP group addresses: IP-G1 and IP-G2
3. Use associated random multicast MAC addresses: MAC-G1 and MAC-G2
4. Select a random value for SVID1 between 1 and 4094
5. Select a random value for SPbit1 between 0 and 7
6. Configure the OLT Emulator to forward all multicast traffic to the multicast GEM Port permanently
7. Cause the OLT Emulator to configure the dynamic access list control table of Multicast Operations Profile ME at the ONU (table index IND1 & IND2)

Table Index	VLAN ID	Multicast source IP address	Multicast IP group address
IND1	SVID1	0.0.0.0	IP-G1
IND2	SVID1	0.0.0.0	IP-G2

8. Cause the OLT Emulator to specify to value 2 the maximum number of dynamic multicast groups that may be replicated at the ONU

9. At the U-interface send IGMP messages to join channels Ch1 and Ch2
10. At the U-interface send IGMP messages to leave channels Ch1 and Ch2
11. Cause the OLT Emulator to specify to value 1 the maximum number of dynamic multicast groups that may be replicated at the ONU
12. At the U-interface send IGMP message to join channel Ch1
13. At the U-interface send IGMP message to join channel Ch2
14. At the U-interface send IGMP messages to leave channel Ch1 and Ch2
15. At the U-interface send IGMP message to join channel Ch2
16. At the U-interface send IGMP message to join channel Ch1
17. At the U-interface send IGMP messages to leave channels Ch1 and Ch2
18. Cause the OLT Emulator to specify to value 2 the maximum number of dynamic multicast groups that may be replicated at the ONU
19. At the U-interface send IGMP messages to join channels Ch1 and Ch2

OMCI Procedure Details

Refer to clause 4.3.

Pass/Fail Criteria

The test passes if the following are true, otherwise the test fails:

1. All OMCI commands have success responses
2. The U-interface does not receive the multicast flows Ch1 and Ch2 at step 6
3. The U-interface does not receive the multicast flows Ch1 and Ch2 at step 7
4. The S/R interface receives the Ch1 and Ch2 Join Message at step 9
5. The U-interface receives the multicast flows Ch1 and Ch2 at step 9
6. The S/R interface receives the Ch1 and Ch2 Leave Message at step 10
7. The U-interface does not receive the multicast flows Ch1 and Ch2 at step 10
8. The S/R interface receives the Ch1 Join Message at step 14
9. The U-interface receives only the multicast flow Ch1 at step 12 and step 13
10. The S/R interface receives the Ch1 Leave Message at step 14

11. The U-interface does not receive the multicast flows Ch1 and Ch2 at step 14
12. The S/R interface receives the Ch2 Join Message at step 15
13. The U-interface receives only the multicast flow Ch2 at step 15 and step 16
14. The S/R interface receives Ch2 Leave Message at step 17
15. The U-interface does not receive the multicast flows Ch1 and Ch2 at step 17
16. The S/R interface receives the Ch1 and Ch2 Join Message at step 19
17. The U-interface receives the multicast flows Ch1 and Ch2 at step 19

Remarks

- None.

6.3.19 Maximum Multicast Bandwidth Modification

Test Name

Maximum Multicast Bandwidth Modification

Test Definition Number

ONU.6.3.19

Reference Document

BBF TR-280 [23]

BBF TR-280 Amendment 1 [24]

ITU-T G.988 [6][7][8]

Test Type

Conformance

Test Requirement Type

Mandatory

Unit Under Test

ONU

Requirement Description

BBF TR-280 Amendment 1

- **R-81** The ONU MUST support the modification of the Maximum Multicast Bandwidth in the Multicast Subscriber Config Info ME without causing any reboot, or MIB reset.
- **R-82** The ONU MUST support the modification of the Maximum Multicast Bandwidth in the Multicast Subscriber Config Info ME without causing any packet loss on existing traffic flows from all the traffic classes and existing active Multicast Groups (as defined in TR-156, R-76).

Note: If the Maximum Multicast Bandwidth value is decreased, no packet loss is expected on the existing active Multicast Groups until the Multicast Channel Subscriber leaves the channel. For example at the beginning 50Mbit/s for multicast traffic is allowed and the Multicast Channel Subscriber reaches the 50Mbit/s, then the Maximum Multicast Bandwidth is set to 45Mbit/s. If the Multicast Channel Subscriber leaves a channel of 5Mbit/s then the associated Multicast Channel is stopped. If the Multicast Channel Subscriber wants to join another channel, the ONU MUST deny the joining as the Maximum Multicast Bandwidth is already reached.

Test Objective

Verify that the ONU is able to modify the maximum multicast bandwidth

Test Configuration

1. OLT Emulator and ONU are powered on and connected to ODN
2. The ONU under test has been activated by the OLT Emulator, has been ranged, and a GEM port for OMCI has been created as a result of ONU-ID assignment
3. A single U-interface is used
4. A bidirectional GEM port, between the ONU under test U-interface and the OLT Emulator, has been created by OMCI, for IGMP messages

Note: The IGMP version is IGMPv2

5. A multicast GEM port, between the ONU under test and the OLT Emulator, has been created by OMCI, for multicast Ethernet frames
6. The Traffic Generator should be configured to transmit the downstream multicast Ethernet frames as defined below:

Channel	Multicast source IP address	Multicast IP group address	Multicast MAC group address	VID	P-bit	Bandwidth kbit/s	Bandwidth kbytes/s
Ch1	IP-S1	IP-G1	MAC-G1	SVID1	SPbit1	2048	256
Ch2	IP-S1	IP-G2	MAC-G2	SVID1	SPbit1	2048	256

Test Procedure

1. Select random value for IP addresses: IP-S1
2. Select distinct random values for multicast IP group addresses: IP-G1 and IP-G2
3. Use associated random multicast MAC addresses: MAC-G1 and MAC-G2
4. Select a random value for SVID1 between 1 and 4094
5. Select a random value for SPbit1 between 0 and 7
6. Configure the OLT Emulator to forward all multicast traffic to the multicast GEM Port permanently
7. Cause the OLT Emulator to configure the dynamic access list control table of the Multicast Operations Profile ME at the ONU (table index IND1 & IND2)

Table Index	VLAN ID	Multicast source IP address	Multicast IP group address	Imputed Group Bandwidth bytes/s
IND1	SVID1	0.0.0.0	IP-G1	512 000
IND2	SVID1	0.0.0.0	IP-G2	512 000

8. Cause the OLT Emulator to specify to 1024 kbytes per second the maximum multicast bandwidth that may be delivered at the ONU and to configure the bandwidth enforcement attribute with the value true
9. At the U-interface send IGMP messages to join channels Ch1 and Ch2
10. At the U-interface send IGMP messages to leave channels Ch1 and Ch2
11. Cause the OLT Emulator to specify to 512 kbytes per second the maximum multicast bandwidth that may be delivered at the ONU
12. At the U-interface send IGMP message to join channel Ch1
13. At the U-interface send IGMP message to join channel Ch2
14. At the U-interface send IGMP messages to leave channel Ch1 and Ch2
15. At the U-interface send IGMP message to join channel Ch2
16. At the U-interface send IGMP message to join channel Ch1
17. At the U-interface send IGMP messages to leave channels Ch1 and Ch2
18. Cause the OLT Emulator to specify to 1024 kbytes per second the maximum multicast bandwidth that may be delivered at the ONU
19. At the U-interface send IGMP messages to join channels Ch1 and Ch2

OMCI Procedure Details

Refer to clause 4.3.

Pass/Fail Criteria

The test passes if the following are true, otherwise the test fails:

1. All OMCI commands have success responses
2. The U-interface does not receive the multicast flows Ch1 and Ch2 at step 6

3. The U-interface does not receive the multicast flows Ch1 and Ch2 at step 7
4. The S/R interface receives the Ch1 and Ch2 Join Message at step 9
5. The U-interface receives the multicast flows Ch1 and Ch2 at step 9
6. The S/R interface receives the Ch1 and Ch2 Leave Message at step 10
7. The U-interface does not receive the multicast flows Ch1 and Ch2 at step 10
8. The S/R interface receives the Ch1 Join Message at step 12
9. The U-interface receives only the multicast flow Ch1 at step 12 and step 13
10. The S/R interface receives the Ch1 Leave Message at step 14
11. The U-interface does not receive the multicast flows Ch1 and Ch2 at step 14
12. The S/R interface receives the Ch2 Join Message at step 15
13. The U-interface receives only the multicast flow Ch2 at step 15 and step 16
14. The S/R interface receives the Ch2 Leave Message at step 17
15. The U-interface does not receive the multicast flows Ch1 and Ch2 at step 17
16. The S/R interface receives the Ch1 and Ch2 Join Message at step 19
17. The U-interface receives the multicast flows Ch1 and Ch2 at step 19

Remarks

- None.

6.3.20 Individual multicast groups in Dynamic Access Control List table

Test Name

Individual multicast groups in Dynamic Access Control List table

Test Definition Number

ONU.6.3.20

Reference Document

BBF TR-280 [23]

BBF TR-280 Amendment 1 [24]

ITU-T G.988 [6][7][8]

Test Type

Conformance

Test Requirement Type

Conditionally Mandatory. This test is mandatory if ONU has applied to Profile F – Enhanced Multicast Operations.

Unit Under Test

ONU

Requirement Description**BBF TR-280 Amendment 1**

- **[R-83]** The ONU MUST support 1024 entries in the Dynamic Access Control list table in the Multicast Operation Profile ME when the Multicast Access Control table is used for admission control.

ITU-T G.988: Multicast operations profile Managed Entity

Attributes:

Dynamic access control list table: This attribute is a list that specifies one or more multicast group address ranges.

Test Objective

Verify that the ONU support individual multicast groups in Dynamic Access Control List table.

Test Configuration

1. OLT Emulator and ONU are powered on and connected to ODN

2. The ONU under test has been activated by the OLT Emulator, has been ranged, and a GEM port for OMCI has been created as a result of ONU-ID assignment
3. A single U-interface is used
4. A bidirectional GEM port, between the ONU under test U-interface and the OLT Emulator, has been created by OMCI, for IGMP messages
Note: The IGMP version is IGMPv2
5. A multicast GEM port, between the ONU under test and the OLT Emulator, has been created by OMCI, for multicast Ethernet frames
6. The Traffic Generator should be configured to transmit the downstream multicast Ethernet frames as defined below:

Channel	Multicast source IP address	Multicast IP group address	Multicast MAC group address	VID	P-bit
Ch1	IP-S1	IP-G1	MAC-G1	SVID1	SPbit1
Ch2	IP-S1	IP-G2	MAC-G2	SVID1	SPbit1
Ch3	IP-S1	IP-G3	MAC-G3	SVID1	SPbit1
Ch4	IP-S1	IP-G4	MAC-G4	SVID1	SPbit1
Ch5	IP-S1	IP-G5	MAC-G5	SVID1	SPbit1

Test Procedure

1. Select random value for IP addresses: IP-S1
2. Select value for multicast IP group address IP-G1: first multicast group of a multicast range containing at least 1000 channels
3. Select value for multicast IP group address IP-G5: last multicast group of a multicast range starting at IP-G1 and containing at least 1000 channels
4. Select distinct random values for multicast IP group addresses IP-G2, IP-G3 and IP-G4 within the multicast range bounded by IP-G1 and IP-G5
5. Use associated random multicast MAC addresses: MAC-G1, MAC-G2, MAC-G3, MAC-G4 and MAC-G5
6. Select a random value for SVID1 between 1 and 4094
7. Select a random value for SPbit1 between 0 and 7
8. Configure the OLT Emulator to forward all multicast traffic to the multicast GEM Port permanently
9. Cause the OLT Emulator to configure the dynamic access list control table of Multicast Operations Profile ME at the ONU (see table below)

VLAN ID	Multicast source IP address	Multicast IP group addresses
SVID1	0.0.0.0	1000 channel entries included in the range defined by IP-G1 – IP-G5

10. At the U-interface send IGMP message to join channel Ch1
11. At the U-interface send IGMP message to leave channel Ch1
12. At the U-interface send IGMP message to join channel Ch2
13. At the U-interface send IGMP message to leave channel Ch2
14. At the U-interface send IGMP message to join channel Ch3
15. At the U-interface send IGMP message to leave channel Ch3
16. At the U-interface send IGMP message to join channel Ch4
17. At the U-interface send IGMP message to leave channel Ch4
18. At the U-interface send IGMP message to join channel Ch5
19. At the U-interface send IGMP message to leave channel Ch5

OMCI Procedure Details

Refer to clause 4.3.

Pass/Fail Criteria

The test passes if the following are true, otherwise the test fails:

1. All OMCI commands have success responses
2. The U-interface does not receive the multicast flows Ch1, Ch2, Ch3, Ch4 and Ch5 at steps 8 and 9
3. The S/R interface receives the Ch1 Join Message at step 10
4. The U-interface receives only the multicast flow Ch1 at step 10
5. The S/R interface receives the Ch1 Leave Message at step 11
6. The U-interface does not receive the multicast flows Ch1, Ch2, Ch3, Ch4 and Ch5 at step 11
7. The S/R interface receives the Ch2 Join Message at step 12
8. The U-interface receives only the multicast flow Ch2 at step 12

9. The S/R interface receives the Ch2 Leave Message at step 13
10. The U-interface does not receive the multicast flows Ch1, Ch2, Ch3, Ch4 and Ch5 at step 13
11. The S/R interface receives the Ch3 Join Message at step 14
12. The U-interface receives only the multicast flow Ch3 at step 14
13. The S/R interface receives the Ch3 Leave Message at step 15
14. The U-interface does not receive the multicast flows Ch1, Ch2, Ch3, Ch4 and Ch5 at step 15
15. The S/R interface receives the Ch4 Join Message at step 16
16. The U-interface receives only the multicast flow Ch4 at step 16
17. The S/R interface receives the Ch4 Leave Message at step 17
18. The U-interface does not receive the multicast flows Ch1, Ch2, Ch3, Ch4 and Ch5 at step 17
19. The S/R interface receives the Ch5 Join Message at step 18
20. The U-interface receives only the multicast flow Ch5 at step 18
21. The S/R interface receives the Ch5 Leave Message at step 19
22. The U-interface does not receive the multicast flows Ch1, Ch2, Ch3, Ch4 and Ch5 at step 19

Remarks

- None.

6.3.21 Whole Multicast Range in Dynamic Access Control List table

Test Name

Whole Multicast Range in Dynamic Access Control List table

Test Definition Number

ONU.6.3.21

Reference Document

BBF TR-280 [23]

ITU-T G.988 [6][7][8]

Test Type

Conformance

Test Requirement Type

Mandatory

Unit Under Test

ONU

Requirement Description**BBF TR-280**

- **[R-23]** The ONU MUST support the following attributes of Multicast Operations Profile ME: Dynamic access control list table

ITU-T G.988: Multicast operations profile Managed Entity

- Attributes:
 - Dynamic access control list table: This attribute is a list that specifies one or more multicast group address ranges.

Test Objective

Verify that the ONU supports whole multicast range in Dynamic Access Control List table as defined per ITU-T G988 standard (224.0.0.0 to 239.255.255.255)

The following two addresses cannot be used in the whole multicast range:

- 224.0.0.2 is reserved for leaves
- 224.0.0.1 is reserved for General Query

Test Configuration

1. OLT Emulator and ONU are powered on and connected to ODN
2. The ONU under test has been activated by the OLT Emulator, has been ranged, and a GEM port for OMCI has been created as a result of ONU-ID assignment
3. A single U-interface is used
4. A bidirectional GEM port, between the ONU under test U-interface and the OLT Emulator, has been created by OMCI, for IGMP messages

Note: The IGMP version is IGMPv2

5. A multicast GEM port, between the ONU under test and the OLT Emulator, has been created by OMCI, for multicast Ethernet frames
6. The Traffic Generator should be configured to transmit the downstream multicast Ethernet frames as defined below:

Channel	Multicast source IP address	Multicast IP group address	Multicast MAC group address	VID	P-bit
Ch1	IP-S1	IP-G1	MAC-G1	SVID1	SPbit1
Ch2	IP-S1	IP-G2	MAC-G2	SVID1	SPbit1
Ch3	IP-S1	IP-G3	MAC-G3	SVID1	SPbit1
Ch4	IP-S1	IP-G4	MAC-G4	SVID1	SPbit1
Ch5	IP-S1	IP-G5	MAC-G5	SVID1	SPbit1

Test Procedure

1. Select random value for IP addresses: IP-S1
2. Set value for multicast IP group address IP-G1 to 224.0.1.0.
3. Set value for multicast IP group address IP-G5 to 239.255.255.255.
4. Select distinct random values for multicast IP group addresses: IP-G2, IP-G3 and IP-G4 from the whole multicast range as defined per ITU-T G988 standard (224.0.0.0 to 239.255.255.255), excluding any reserved multicast addresses
5. Use associated random multicast MAC addresses: MAC-G1, MAC-G2, MAC-G3, MAC-G4 and MAC-G5
6. Select a random value for SVID1 between 1 and 4094
7. Select a random value for SPbit1 between 0 and 7
8. Configure the OLT Emulator to forward all multicast traffic to the multicast GEM Port permanently
9. Cause the OLT Emulator to configure the dynamic access list control table of Multicast Operations Profile ME at the ONU (table index IND1)

Table Index	VLAN ID	Multicast source IP address	Multicast IP group address
IND1	SVID1	0.0.0.0	The whole multicast range as defined per ITU-T G988 standard (224.0.0.0 to 239.255.255.255)

10. At the U-interface send IGMP message to join channel Ch1
11. At the U-interface send IGMP message to leave channel Ch1
12. At the U-interface send IGMP message to join channel Ch2
13. At the U-interface send IGMP message to leave channel Ch2
14. At the U-interface send IGMP message to join channel Ch3
15. At the U-interface send IGMP message to leave channel Ch3
16. At the U-interface send IGMP message to join channel Ch4
17. At the U-interface send IGMP message to leave channel Ch4
18. At the U-interface send IGMP message to join channel Ch5
19. At the U-interface send IGMP message to leave channel Ch5

OMCI Procedure Details

Refer to clause 4.3.

Pass/Fail Criteria

The test passes if the following are true, otherwise the test fails:

1. All OMCI commands have success responses
2. The U-interface does not receive the multicast flows Ch1, Ch2, Ch3, Ch4 and Ch5 at steps 8 and 9
3. The S/R interface receives the Ch1 Join Message at step 10
4. The U-interface receives only the multicast flow Ch1 at step 10
5. The S/R interface receives the Ch1 Leave Message at step 11
6. The U-interface does not receive the multicast flows Ch1, Ch2, Ch3, Ch4 and Ch5 at step 11

7. The S/R interface receives the Ch2 Join Message at step 12
8. The U-interface receives only the multicast flow Ch2 at step 12
9. The S/R interface receives the Ch2 Leave Message at step 13
10. The U-interface does not receive the multicast flows Ch1, Ch2, Ch3, Ch4 and Ch5 at step 13
11. The S/R interface receives the Ch3 Join Message at step 14
12. The U-interface receives only the multicast flow Ch3 at step 14
13. The S/R interface receives the Ch3 Leave Message at step 15
14. The U-interface does not receive the multicast flows Ch1, Ch2, Ch3, Ch4 and Ch5 at step 15
15. The S/R interface receives the Ch4 Join Message at step 16
16. The U-interface receives only the multicast flow Ch4 at step 16
17. The S/R interface receives the Ch4 Leave Message at step 17
18. The U-interface does not receive the multicast flows Ch1, Ch2, Ch3, Ch4 and Ch5 at step 17
19. The S/R interface receives the Ch5 Join Message at step 18
20. The U-interface receives only the multicast flow Ch5 at step 18
21. The S/R interface receives the Ch5 Leave Message at step 19
22. The U-interface does not receive the multicast flows Ch1, Ch2, Ch3, Ch4 and Ch5 at step 19

Remarks

None.

6.4 Non-IGMP Controlled Multicast and Broadcast

6.4.1 Downstream Broadcast Handling, Single U-interface

Test Name

Downstream Broadcast Handling, Single U-interface

Test Definition Number

ONU.6.4.1

Reference Document

BBF TR-156 [20]

ITU-T G.988 [6][7][8]

Test Type

Conformance

Test Requirement Type

Mandatory

Unit Under Test

ONU

Requirement Description**TR-156:**

- **R-113** If the ONU receives a tagged frame on a downstream GEM Port, it **MUST** forward it to all U-interfaces that are members of that VLAN.

Test Objective

Verify the ONU passes frames with broadcast destination MAC addresses in the downstream direction to all U-interfaces that are members of the VLAN contained in the frame's headers. This test is performed on ONU devices with 1 U-interface.

Test Configuration

1. The ONU is powered and connected to the ODN
2. The ONU has been activated by the OLT Emulator, has been ranged, and a GEM port for OMCI has been created as a result of ONU-ID assignment.
3. The OLT Emulator has instructed the ONU to reset its MIB to factory default values.
4. ONU has successfully completed test cases in section 6.1.

5. The Ethernet Traffic Generator and the OLT Emulator should be configured to transmit the following downstream Ethernet frames:

Downstream Direction																							
Traffic Stream	S/R Interface														U Interface								
	MAC DA	MAC SA	Outer VLAN Tag				Inner VLAN Tag				Ethertype	IP DA	IP SA	GEM	Outer VLAN Tag				Inner VLAN Tag				UNI
	Value	Value	TPID	Pbits	DEI	VID	TPID	Pbits	CFI or DEI	VID	Value	Value	Value	Port #	TPID	Pbits	DEI	VID	TPID	Pbits	CFI or DEI	VID	Port #
A	MAC-BRD	MAC1	n/a	n/a	n/a	n/a	0x88A8	0	0	SVID1	x	x	x	GEM2	n/a	n/a	n/a	n/a	n/a	n/a	n/a	n/a	1
B	MAC-BRD	MAC1	n/a	n/a	n/a	n/a	0x88A8	0	0	SVID2	x	x	x	GEM2	-	-	-	-	-	-	-	-	-

Test Procedure

1. Select distinct random values for SVID1 and SVID2 between 1 and 4094.
2. Select random value for MAC1.
3. Configure the OLT Emulator to use the OMCI message sequence below to provision the ONU to support:
 - A single untagged U-interface, member only of SVID1
 - Additional/removal of the S-tag in the upstream/downstream directions, respective (making the U-interface a member of the VLAN).
4. Enable capture on the Ethernet traffic generator.
5. Cause the Ethernet Traffic Generator and the OLT Emulator to transmit the downstream frame(s) described above in stream A and stream B.

OMCI Procedure Details

Refer to clause 4.3.

Pass/Fail Criteria

The test passes if the following are true, otherwise the test fails:

1. Each OMCI response message must indicate success for the associated create or set command.
2. The uploaded ONU MIB must be consistent with the MIB held in the OLT Emulator
3. The downstream frames in stream A must be received as untagged Ethernet frames.
4. The downstream frames in stream B must not be received by the Ethernet Traffic Generator.

Remarks

- None.

6.4.2 Downstream Broadcast Handling, Multiple U-interfaces

Test Name

Downstream Broadcast Handling, Multiple U-interfaces

Test Definition Number

ONU.6.4.2

Reference Document

BBF TR-156 [20]

ITU-T G.988 [6][7][8]

Test Type

Conformance

Test Requirement Type

Conditionally Mandatory (if ONT has multiple user ports)

Unit Under Test

ONU

Requirement Description

BBF TR-156:

- **R-113** If the ONU receives a tagged frame on a downstream GEM Port, it MUST forward it to all U-interfaces that are members of that VLAN.

Test Objective

Verify the ONU passes frames with broadcast destination MAC addresses in the downstream direction to all U-interfaces that are members of the VLAN contained in the frame's headers. This test is performed on ONU devices with multiple U-interfaces.

Test Configuration

1. The ONU is powered and connected to the ODN
2. The ONU has been activated by the OLT Emulator, has been ranged, and a GEM port for OMCI has been created as a result of ONU-ID assignment.
3. The OLT Emulator has instructed the ONU to reset its MIB to factory default values.
4. ONU has successfully completed test cases in section 6.1.
5. The Ethernet Traffic Generator and the OLT Emulator should be configured to transmit the following downstream Ethernet frames:

Downstream Direction																							
Traffic Stream	S/R Interface													U Interface									
	MAC DA	MAC SA	Outer VLAN Tag				Inner VLAN Tag				Ethertype	IP DA	IP SA	GEM	Outer VLAN Tag				Inner VLAN Tag				UNI
	Value	Value	TPID	Pbits	DEI	VID	TPID	Pbits	CFI or DEI	VID	Value	Value	Value	Port #	TPID	Pbits	DEI	VID	TPID	Pbits	CFI or DEI	VID	Port #
A	MAC-BRD	MAC1	n/a	n/a	n/a	n/a	0x88A8	0	0	SVID1	x	x	x	GEM3	n/a	n/a	n/a	n/a	n/a	n/a	n/a	n/a	1 & 2
B	MAC-BRD	MAC1	n/a	n/a	n/a	n/a	0x88A8	0	0	SVID2	x	x	x	GEM3	-	-	-	-	-	-	-	-	-

Test Procedure

1. Select distinct random values for SVID1 and SVID2 between 1 and 4094.
2. Select random value for MAC1.
3. Configure the OLT Emulator to use the OMCI message sequence below to provision the ONU to support:
 - A two untagged U-interfaces, both members of only SVID1
 - Additional/removal of the S-tag in the upstream/downstream directions, respective (making the U-interface a member of the VLAN).
4. Enable capture on the Ethernet traffic generator.
5. Cause the Ethernet Traffic Generator and the OLT Emulator to transmit the downstream frame(s) described above in Stream A and Stream B.

OMCI Procedure Details

Refer to clause 4.3.

Pass/Fail Criteria

The test passes if the following are true, otherwise the test fails:

1. Each OMCI response message must indicate success for the associated create or set command.
2. The uploaded ONU MIB must be consistent with the MIB held in the OLT Emulator
3. The downstream frames in Stream A must be received as untagged Ethernet frames from both U-interfaces.
4. The downstream frames in Stream B must not be received by the Ethernet Traffic Generator from either of the U-interfaces.

Remarks

- None.

6.5 Filtering

6.5.1 Test Case Reserved For Future Use

6.5.2 Test Case Reserved For Future Use

6.5.3 Test Case Reserved For Future Use

6.5.4 Test Case Reserved For Future Use

6.5.5 Test Case Reserved For Future Use

6.5.6 Test Case Reserved For Future Use

6.5.7 Test Case Reserved For Future Use

6.5.8 Test Case Reserved For Future Use

6.5.9 Test Case Reserved For Future Use

6.6 TR-156 Other

6.6.1 2000-Byte Frames Supported by the ONU

Test Name

2000-Byte Frames Supported by the ONU

Test Definition Number

ONU.6.6.1

Reference Document

BBF TR-156 [20] Section 4.4

ITU-T G.988 [6][7][8]

Test Type

Conformance

Test Requirement Type

Conditionally Mandatory.

This test is not applicable for TR-301 Model 2 Gfast DPU ONUs whose System Under Test does not support 2000-byte frames size and is Mandatory for all other ONU types.

Unit Under Test

ONU

Requirement Description**BBF TR-156**

- **R-4** The ONU/ONT MUST support frame size of 2000 bytes as per IEEE 802.3as

Test Objective

Verify that the ONU supports frame size of 2000 bytes as per IEEE 802.3as

Test Configuration

1. OLT Emulator and ONU under test are powered and connected to ODN
2. ONU under test has been activated by the OLT Emulator, has been ranged, and a GEM port for OMCI has been created by PLOAM.
3. The Ethernet Traffic Generator is configured to transmit tagged Ethernet frames with frame size of 2000 bytes as per IEEE 802.3as upstream with the following parameters:

Upstream Direction																								
Traffic Stream	U Interface														R/S Interface									
	UNI	MAC DA	MAC SA	Outer VLAN Tag				Inner VLAN Tag				Ethertype	IP DA	IP SA	Outer VLAN Tag				Inner VLAN Tag				GEM	T-CONT
	Port #	Value	Value	TPID	Pbits	DEI	VID	TPID	Pbits	CFI or DEI	VID	Value	Value	Value	TPID	Pbits	DEI	VID	TPID	Pbits	CFI or DEI	VID	Port #	Number
A	1	MAC1	MAC2	n/a	n/a	n/a	n/a	0x8100	SPbits1	x	SVID1	x	x	x	n/a	n/a	n/a	n/a	0x8100	SPbits1	x	SVID1	GEM1	TCONT1

- The Ethernet Traffic Generator is configured to transmit tagged Ethernet frames with frame size of 2000 bytes as per IEEE 802.3as downstream with the following parameters:

Downstream Direction																							
Traffic Stream	S/R Interface														U Interface								
	MAC DA	MAC SA	Outer VLAN Tag				Inner VLAN Tag				Ethertype	IP DA	IP SA	GEM	Outer VLAN Tag				Inner VLAN Tag				UNI
	Value	Value	TPID	Pbits	DEI	VID	TPID	Pbits	CFI or DEI	VID	Value	Value	Value	Port #	TPID	Pbits	DEI	VID	TPID	Pbits	CFI or DEI	VID	Port #
A	MAC2	MAC1	n/a	n/a	n/a	n/a	0x8100	SPbits1	x	SVID1	x	x	x	GEM1	n/a	n/a	n/a	n/a	0x8100	SPbits1	x	SVID1	1

Test Procedure

- Select distinct random values for SVID1 and SPbits1
- Select distinct random values for the unicast MAC Addresses MAC1 and MAC2
- Use the OLT Emulator to provision the ONU under test (via defined OMCI messages below) to support one subscriber with user traffic class, requiring 1 GEM port (Alloc-ID, T-CONT, Port-ID).
- Enable any frame monitoring/capture mechanisms on the Ethernet Traffic Generator/Analyzer.
- Cause the Ethernet Traffic Generator/Analyzer to transmit upstream Ethernet frames with the characteristics described in the test configuration section.
- Cause the Ethernet Traffic Generator/Analyzer to transmit downstream Ethernet frames with the characteristics described in the test configuration section

OMCI Procedure Details

Refer to clause 4.3.

Pass/Fail Criteria

- Each OMCI response message must indicate success for the associated create or set command.
- The uploaded ONU MIB must be consistent with the MIB held in the OLT Emulator
- All upstream 2000-byte frames sent by the Ethernet Traffic Generator/Analyzer must be received error free by the OLT Emulator at the S/R interface

4. All downstream 2000-byte frames sent by the Ethernet Traffic Generator/Analyzer must be received error free by the Ethernet Traffic Generator/Analyzer at the U interface

Remarks

- None.

6.6.2 Test Case Reserved For Future Use

6.7 Initial provisioning of ONU

6.7.1 Local setting of a registration ID at the ONU (ONU retains the Registration ID indefinitely)

Test Name

Local setting of a registration ID at the ONU (ONU retains the Registration ID indefinitely)

Test Definition Number

ONU.6.7.1

Reference Document

BBF TR-156 [20]

ITU-T G.988 [6][7][8]

Test Type

Conformance

Test Requirement Type

Conditionally Mandatory.

This test is not applicable to TR-301 Model 2 Gfast DPU ONU type, and Mandatory to all other ONU types.

Unit Under Test

ONU

Requirement Description

- **R-152** ONU that support the registration ID approach **MUST** support the local setting of a registration ID
- **R-153** ONU that support the registration ID approach **MUST** retain the registration ID indefinitely

Test Objective

To verify that the ONU retains indefinitely the Registration ID

Test Configuration

1. The OLT Emulator and ONU under test are connected to the same ODN
2. The ONU under test is power off.
3. Deactivate ONU autodiscover mode if this functionality is available at the OLT Emulator

Test Procedure

1. Use a local management interface to enter the registration ID at the ONU
2. Set the Registration ID of the ONU and provision it in the OLT Emulator. For XGS-PON ONUs, test must be performed using a Registration ID of length strictly greater than 10 characters and possibly equal to 36 characters.
3. Through the G-PON Analyser or OLT Emulator, verify that the ONU ranges using the Registration ID
4. Power off the ONU
5. Power on the ONU
6. Through the G-PON Analyser or OLT Emulator, verify that the ONU ranges using the Registration ID set at as step 1

OMCI Procedure Details

Refer to clause 4.3.

Pass/Fail Criteria

The test passes if the following are true, otherwise the test fails:

1. The test is passed if the Registration ID entered at step 1 above is sent on the PON by the ONU for ranging after step 3 and step 5

Remarks

- None.

6.8 ONU Bring-up

6.8.1 New ONU Bring-up method for new ONU

Test Name

New ONU Bring-up method for new ONU

Test Definition Number

ONU.6.8.1

Reference Document

ITU-T G.988 [6][7][8]

Test Type

Conformance

Test Requirement Type

Mandatory

Unit Under Test

ONU

Requirement Description

ITU-T G.988 Appendix I

Test Objective

To verify that a new ONU, that is, an ONU that has never completed the OLT's MIB synchronization process, correctly completes the New ONU Bring-up method as described in ITU-T G.988 [6][7][8].

Test Configuration

1. ONU has never been provisioned or if it has, it has been de-provisioned.
2. ONU is powered off and connected to the ODN.
3. OLT Emulator is powered on, active and connected to the ODN.
4. The OLT Emulator should be configured to send the sequence of PLOAM and OMCI messages required to fulfill the ONU activation process, the OMCC establishment, MIB synchronization and MIB upload processes.

Test Procedure

1. Power the ONU on.
2. Cause the OLT Emulator to execute the ONU activation process [2].
3. Cause the OLT Emulator to establish the OMCI channel, that is, to activate a GEM port for OMCI, as specified in section 7.2.1 of ITU-T G.988 [6][7][8].
4. Cause the OLT Emulator to send the OMCI message sequence specified in the OMCI Procedure Details.
5. Cause the OLT Emulator to get the current ONU's MIB data sync attribute.

OMCI Procedure Details

Refer to clause 4.3.

Pass/Fail Criteria

The test passes if the following are true, otherwise the test fails:

1. After ONU activation and OMCC establishment, the ONU answers to all the OMCI messages sent by the OLT Emulator.
2. All the OMCI response messages are syntactically correct and the responses associated to MIB reset, Set, Create and/or Delete commands indicate "command successfully processed".
3. The uploaded ONU's MIB and MIB data sync value in step 5 of the Test Procedure must match the value + 1 set by in the OLT Emulator as part of the bring up procedure.

Remarks

- Old and new ONU as defined in G.988 [6][7][8] Appendix I.

6.8.2 New ONU Bring-up method for old ONU

Test Name

New ONU Bring-up method for old ONU

Test Definition Number

ONU.6.8.2

Reference Document

ITU-T G.988 [6][7][8]

Test Type

Conformance

Test Requirement Type

Mandatory

Unit Under Test

ONU

Requirement Description

ITU-T G.988 Appendix I

Test Objective

To verify that an old ONU, that is, an ONU that has previously completed the OLT's MIB synchronization process, correctly completes the New ONU Bring-up method.

Test Configuration

1. ONU has previously been provisioned. For example, it has successfully passed test ONU-6.8.1.
2. OLT Emulator is powered on, active and connected to the ODN.
3. ONU is powered on and has successfully achieved MIB synchronization.
4. The OLT Emulator should be configured to send the sequence of PLOAM and OMCI messages required to fulfill the ONU activation process, the OMCC establishment, MIB synchronization and MIB upload processes.

Test Procedure

1. Disconnect the ONU from the ODN.
2. Re-connect the ONU to the ODN.

3. Cause the OLT Emulator to execute the ONU activation process [2].
4. Cause the OLT Emulator to establish the OMCI channel, that is, to activate a GEM port for OMCI, as specified in section 7.2.1 of ITU-T G.988 [6][7][8].
5. Cause the OLT Emulator to send the OMCI message sequence specified in the OMCI Procedure Details.
6. Cause the OLT Emulator to get the current ONU's MIB data sync attribute.

OMCI Procedure Details

Refer to clause 4.3.

Pass/Fail Criteria

The test passes if the following are true, otherwise the test fails:

1. After ONU activation and OMCC establishment, the ONU answers to all the OMCI messages sent by the OLT Emulator.
2. All the OMCI response messages are syntactically correct and the responses associated with MIB reset, Set, Create and/or Delete commands indicate "command successfully processed".
3. The uploaded ONU's MIB and MIB data sync value in step 5 of the Test Procedure must match the value + 1 set by in the OLT Emulator as part of the bring up procedure.

Remarks

- None.

6.8.3 Old ONU Bring-up method for ONU

Test Name

Old ONU Bring-up method for ONU

Test Definition Number

ONU.6.8.3

Reference Document

ITU-T G.988 [6][7][8]

Test Type

Conformance

Test Requirement Type

Mandatory

Unit Under Test

ONU

Requirement Description

ITU-T G.988 Appendix I

Test Objective

To verify that an old ONU, that is, an ONU that has previously completed the OLT's MIB synchronization process, correctly completes the Old ONU Bring-up method as described in Appendix I of ITU-T G.988 [6][7][8].

Test Configuration

1. ONU has previously been provisioned. For example, it has successfully passed test ONU-6.8.1.
2. OLT Emulator is powered on, active and connected to the ODN.
3. ONU is powered on and has successfully achieved MIB synchronization.
4. The OLT Emulator should be configured to send the sequence of PLOAM and OMCI messages required to fulfill the ONU activation process, the OMCC establishment, MIB synchronization and MIB upload processes.

Test Procedure

1. Disconnect the ONU from the ODN.
2. Re-connect the ONU to the ODN.

3. Cause the OLT Emulator to execute the ONU activation process [2].
4. Cause the OLT Emulator to establish the OMCI channel, that is, to activate a GEM port for OMCI, as specified in section 7.2.1 of ITU-T G.988 [6][7][8] .
5. Cause the OLT Emulator to send the OMCI message sequence specified in the OMCI Procedure Details.
6. Cause the OLT Emulator to get the current ONU's MIB data sync attribute.

OMCI Procedure Details

Refer to clause 4.3.

Pass/Fail Criteria

The test passes if the following are true, otherwise the test fails:

1. After ONU activation and OMCC establishment, the ONU answers to all the OMCI messages sent by the OLT Emulator.
2. All the OMCI response messages are syntactically correct and the responses associated with Set, Create and/or Delete commands indicate "command successfully processed".
3. The uploaded ONU's MIB and MIB data sync value in step 5 of the Test Procedure must match the value + 1 set by in the OLT Emulator as part of the bring up procedure.

Remarks

- None.

6.8.4 New ONU Bring-up method for new ONU with encrypted OMCC

Test Name

New ONU Bring-up method for new ONU with encrypted OMCC

Test Definition Number

ONU.6.8.4

Reference Document

ITU-T G.988 [6][7][8]

Test Type

Conformance

Test Requirement Type

Mandatory

Unit Under Test

ONU

Requirement Description

ITU-T G.988 section 7.2.2 Encryption

Test Objective

The purpose of the test is to verify that an ONU is able to complete the OMCI synchronisation with the OMCC channel encrypted.

Test Configuration

1. ONU has never been provisioned or if it has, it has been de-provisioned.
2. ONU successfully completed Test ONU-6.8.1.
3. ONU is powered off and connected to the ODN.
4. OLT Emulator is powered on, active and connected to the ODN.

The OLT Emulator should be configured to send the sequence of PLOAM and OMCI messages required to fulfill the ONU activation process, the AES key exchange, the OMCC establishment, the OMCC configuration as an encrypted Port-ID, MIB synchronization and MIB upload processes.

Test Procedure

1. Power On the ONU.
2. Cause the OLT Emulator to execute the ONU activation process [2].

3. Cause the OLT Emulator to establish the OMCI channel, that is, to activate a GEM port for OMCI, as specified in section 7.2.1 of ITU-T G.988 [6][7][8].
4. Cause the OLT Emulator to request generation, exchange and activation of a new AES key by the ONU.
5. Once the new key activation has succeeded, cause the OLT Emulator to set the Encryption Status of the OMCC channel to Encrypted.
6. Cause the OLT Emulator to send the OMCI message sequence specified in the OMCI Procedure details.
7. Cause the OLT Emulator to get the current ONU's MIB data sync attribute.

OMCI Procedure Details

Refer to clause 4.3.

Pass/Fail Criteria

The test passes if the following are true, otherwise the test fails:

1. At step 4 of the Test Procedure, the new key activation succeeds.
2. At steps 4 and 5 of the Test Procedure, the ONU acknowledges the commands from the OLT Emulator.
3. After ONU activation and OMCC establishment, the ONU answers to all the OMCI messages sent by the OLT Emulator.
4. All the OMCI response messages are syntactically correct and the responses associated to MIB reset, Set, Create and/or Delete commands indicate "command successfully processed".
5. The uploaded ONU's MIB and MIB data sync value in step 9 of the Test Procedure must match the value + 1 set by in the OLT Emulator as part of the bring up procedure.

Remarks

- None.

6.8.5 OMCI Version During New ONU Bring Up

Test Name

OMCI Version During New ONU Bring Up

Test Definition Number

ONU.6.8.5

Reference Document

BBF TR-280 [23]

BBF TR-280 Amendment 1 [24]

ITU-T G.988 [6][7][8]

Test Type

Conformance

Test Requirement Type

Mandatory

Unit Under Test

ONU

Requirement Description

ITU-T G.988 section 11.1

BBF TR-280 Amendment 1

- **R-87** The ONU MUST report the supported OMCI version with the ONU2-G ME.

Test Objective

Verify that the ONU is able to send the OMCI version supported by the ONU during a new ONU bring up.

Test Configuration

1. ONU has never been provisioned or if it has, it has been de-provisioned.
2. ONU is powered off and connected to the ODN.
3. OLT Emulator is powered on, active and connected to the ODN.

4. The OLT Emulator should be configured to send the sequence of PLOAM and OMCI messages required to fulfill the ONU activation process, the OMCC establishment, OMCI version supported.

Test Procedure

1. Power the ONU on.
2. Cause the OLT Emulator to execute the ONU activation process from ITU-T G.988 [6][7][8].
3. Cause the OLT Emulator to establish the OMCI channel, that is, to activate a GEM port for OMCI, as specified in section Annex B.1 of ITU-T G.988 [6][7][8].
4. Cause the OLT Emulator to get the attribute “Optical network unit management and control channel (OMCC) version” of the ME “ONU2-G” (Baseline OMCI)

OMCI Procedure Details

Refer to clause 4.3.

Pass/Fail Criteria

The test passes if the following are true, otherwise the test fails:

1. After ONU activation and OMCC establishment, the ONU answers to all the OMCI messages sent by the OLT Emulator.
2. The ONU is able to report valid values the OMCC version at step 4.

Remarks

- None.

6.9 MIB and Alarm Synchronization

6.9.1 Alarm synchronization

Test Name

Alarm synchronization

Test Definition ID

ONU.6.9.1

Reference Document

ITU-T G.988 [6][7][8]

Test Type

Conformance

Test Requirement Type

Conditionally Mandatory

Mandatory if ONU is NOT a multi-managed ONU.

Unit Under Test

ONU

Requirement Description

ITU-T G.988 Appendix I

Test Objective

The purpose of this test is to verify that the ONU is able, first to upload its alarm table when the OLT detects an alarm mismatch value and second to increment its Alarm sequence number value.

Test Configuration

1. OLT Emulator and ONU under test are powered and connected to ODN
2. ONU under test has been activated by the OLT Emulator, ranged, and a GEM port for OMCI has been created as a result of ONU-ID assignment.
3. Ethernet traffic generator is connected with the ONU under test and Ethernet port of the ONU under test is up. No need of Ethernet traffic

Test Procedure

1. Cause an ONU OMCI alarm via an external stimulus (for example by disconnecting the Ethernet cable from an ONU's Ethernet UNI)
2. The OLT Emulator sends a Get All Alarms OMCI message

3. Verify that the ONU uploads its alarm table
4. Once alarm synchronisation process is finished, remove the cause of the alarm. Verify that the ONU sends an Alarm OMCI message and increment its Alarm sequence number value

OMCI Procedure Details

Refer to clause 4.3.

Pass/Fail Criteria

The test passes if the following are true, otherwise the test fails:

1. The ONU answers to all the OMCI messages send by the OLT Emulator.
2. The ONU follows OMCI messages exchanges described in OMCI procedure detailed in ITU-T G.988 [6][7][8]
3. The ONU is able to send an Alarm OMCI message notifying that the alarm previously created is cleared.
4. The ONU is able to increment its Alarm sequence number value

Remarks

- None.

6.9.2 MIB synchronization: Correct Data Sync

Test Name

MIB synchronization: Correct Data Sync

Test Definition ID

ONU.6.9.2

Reference Document

ITU-T G.988 [6][7][8]

Test Type

Conformance

Test Requirement Type

Mandatory

Unit Under Test

ONU

Requirement Description

ITU-T G.988 Appendix I

Test Objective

The purpose of this test is to verify that the ONU is able to answer with the right MIB Data Sync value

Test Configuration

1. OLT Emulator and ONU under test are powered and connected to ODN
2. ONU under test has been activated by the OLT Emulator, ranged, and a GEM port for OMCI has been created as a result of ONU-ID assignment.

Test Procedure

1. Using the OLT Emulator, set the ONT Data MIB Synch value
2. Using the OLT Emulator, send a get ONT MIB Data Sync OMCI message
3. Verify that the ONU answers with the previously set MIB Data Sync value incremented by 1

OMCI Procedure Details

Refer to clause 4.3.

Pass/Fail Criteria

The test passes if the following are true, otherwise the test fails:

1. The ONU answers to all the OMCI messages sent by the OLT Emulator.
2. The ONU under test answers with the MIB Data Sync value incremented.
3. The ONU follows OMCI messages exchanges described in OMCI procedure detailed in ITU-T G.988 [6][7][8].

Remarks

- None.

6.9.3 MIB synchronization: MIB Upload

Test Name

MIB synchronization: MIB Upload

Test Definition ID

ONU.6.9.3

Reference Document

ITU-T G.988 [6][7][8]

Test Type

Conformance

Test Requirement Type

Mandatory

Unit Under Test

ONU

Requirement Description

ITU-T G.988 Appendix I

Test Objective

The purpose of this test is to verify that the ONU is able to upload its MIB on request of the OLT.

Test Configuration

1. OLT Emulator and ONU under test are powered and connected to ODN
2. ONU under test has been activated by the OLT Emulator, ranged, and a GEM port for OMCI has been created as a result of ONU-ID assignment.

Test Procedure

1. Using the OLT Emulator send a MIB Upload ONT Data
2. Verify that the ONU uploads its MIB

OMCI Procedure Details

Refer to clause 4.3.

Pass/Fail Criteria

The test passes if the following are true, otherwise the test fails:

1. The ONU answers to all the OMCI messages sent by the OLT Emulator.
2. The ONU under test uploads its MIB
3. The ONU follows OMCI messages exchanges described in OMCI procedure detailed in ITU-T G.988 [6][7][8]

Remarks

- None.

6.9.4 U interface status reporting and alarms

Test Name

U interface status reporting and alarms

Test Definition Number

ONU.6.9.4

Reference Document

BBF TR-280 [23]

ITU-T G.988 [6][7][8]

Test Type

Conformance

Test Requirement Type

Conditionally Mandatory

Mandatory if ONU is NOT a multi-managed ONU and if ONU is implementing Physical Ethernet interfaces that can negotiate in Fast Ethernet (100 Mbps) and Gigabit Ethernet (1000 Mbps).

Unit Under Test

ONU

Requirement Description

BBF TR-280

- **R-48** The ONU MUST allow reading of the type and status for each U interface
- **R-49** The ONU MUST send an alarm for operational status changes on the U interface
- **R-51** If U interface Type is Ethernet, the U interface MUST report:
 - Ethernet synchronization mode
 - Ethernet synchronization speed

Test Objective

Verify that the ONU is able to send all information related to the U interface (status reporting and alarms).

Note 1: In this test, when the ONU has originally all of its Ethernet local ports disconnected before power is applied, it is expected that the ONU initialization phase results in the generation of a LAN-LOS alarm in the Ethernet PPTP ME

Note 2: In this test, when the ONU has originally been rebooted, the same alarms are expected to be observed as well after a "reBoot + MIB reset" as after a second (or more) MIB reset(s).

Test Configuration

1. OLT Emulator is powered and connected to ODN. ONU under test is connected to the PON, is powered OFF and then powered ON.
2. ONU under test has been activated by the OLT Emulator, has been ranged, and a GEM port for OMCI has been created as a result of ONU-ID assignment.
3. Cause the OLT Emulator to send a MIB reset to the ONU under test.
4. The OLT Emulator configures through OMCI the ONU under test
 - to support 1 traffic classes (i.e., P-bit mapping)
 - with 1 GEM ports and 1 downstream queue
5. The ONU has all of its Ethernet local ports disconnected, meaning the ONU has no Ethernet link active (specifically the ONU and the Ethernet Traffic Generator are disconnected).

Test Procedure

1. Cause the OLT Emulator to capture any Attribute Value Change (AVC) and alarms sent by the ONU for the U interface
2. Cause the OLT Emulator to send the configured OMCI message sequence to provision the ONU.
3. Cause the OLT Emulator to perform a GET_ALL_ALARMS & GET_ALL_ALARMS_NEXT to the ONU
4. Cause the OLT Emulator to retrieve the status of the U interface (PPTP Ethernet UNI ME).
5. Connect the traffic generator (configure at 1000Mbit/s autoneg) with the U interface of the ONU.
6. Wait that all AVC and alarms are sent by the ONU.
7. Cause the OLT Emulator to retrieve the status of the U interface.
8. Disconnect the traffic generator with the U interface of the ONU
9. Wait that all AVC and alarms are sent by the ONU.
10. Cause the OLT Emulator to retrieve the status of the U interface.
11. Connect the traffic generator (configure at 100Mbit/s autoneg) with the U interface of the ONU.
12. Wait that all AVC and alarms are sent by the ONU.

13. Cause the OLT Emulator to retrieve the status of the U interface.
14. Cause the OLT Emulator to send a MIB reset to the ONU under test.
15. Repeat step 1 to step 13.

OMCI Procedure Details

Refer to clause 4.3.

Pass/Fail Criteria

The test passes if the following are true, otherwise the test fails:

1. The ONU is able to send alarms at step 3 (alarm "LAN-LOS")
2. The ONU is able to send the status of the U interface at step 4 (attribute "Auto detection configuration" at 0x00, "Administrative state" at 0x00, "Configuration ind" at 0x00)
3. The ONU is able to send alarms at step 6 (Alarm message with the LAN-LOS alarm bit cleared)
4. The ONU is able to send the status of the U interface at step 7 (attribute "Auto detection configuration" at 0x00, "Administrative state" at 0x00, "Configuration ind" at 0x03)
5. The ONU is able to send alarms at step 9 (alarm "LAN-LOS")
6. The ONU is able to send the status of the U interface at step 10 (attribute "Auto detection configuration" at 0x00, "Administrative state" at 0x00, "Configuration ind" at 0x00)
7. The ONU is able to send alarms at step 12 (Alarm message with the LAN-LOS alarm bit cleared)
8. The ONU is able to send the status of the U interface at step 13 (attribute "Auto detection configuration" at 0x00, "Administrative state" at 0x00, "Configuration ind" at 0x02)
9. Results from Step 15 must be identical to results required from step 1 to step 13.

Remarks

- None.

6.9.5 Optical parameters counters and alarms

Test Name

Optical parameters counters and alarms

Test Definition Number

ONU.6.9.5

Reference Document

BBF TR-280 [23]

ITU-T G.988 [6][7][8]

Test Type

Conformance

Test Requirement Type

Mandatory

Unit Under Test

ONU

Requirement Description

BBF TR-280

- [R-41] The ONU/OLT MUST measure and report :
 - ONU temperature
 - ONU Voltage
 - ONU bias Current
 - ONU Tx power
 - ONU received power
- [R-43] The OLT MUST be able to configure optical thresholds via OMCI (ME ANI-G G.988) at the ONU. The ONU MUST be able to configure optical thresholds and send alarms (via OMCI) when threshold are reached for:
 - Low received optical power

- High received optical power
- Low transmit optical power
- High transmit optical power

Test Objective

Verify that the ONU is able to Optical parameters counters and alarms.

Test Configuration

1. OLT Emulator and ONU under test are powered and connected to ODN, the ODN class must be B+ or N1 depending of the PON technology
2. PON power meter is connected between the ONU and the OLT
3. ONU under test has been activated by the OLT Emulator, has been ranged, and a GEM port for OMCI has been created as a result of ONU-ID assignment.
4. Set ANI-G attributes Lower Optical Threshold, Upper optical Threshold, Lower Transmit Power Threshold, Upper Transmit Power Threshold to their default value as defined in G.988 (ONU internal policy).

Test Procedure

1. Measure with PON power meter Tx and Rx Power and note the value
2. Get and record the Optical parameters (Rx power attribute “Optical signal level”, Tx power) defined in the ANI-G ME
3. Test and record the “test result” for the Optical parameters (Rx or “received optical power”, Tx or “Mean optical launch power”, I_{bias} or “Laser Bias Current, V_{bias} or “power feed voltage”, Temperature) defined in the ANI-G ME
4. Set the “Lower optical threshold” attribute to the value Rx(dBm) obtained at step 3 + 1(dB)
5. Wait for the alarm “Low received optical power”
6. Set the “Lower optical threshold” attribute to the value Rx(dBm) obtained at step 3 - 1(dB)
7. Wait till the alarm “Low received optical power” is cleared
8. Set the “Upper optical threshold” attribute to the value Rx(dBm) obtained at step 3 - 1(dB)
9. Wait for the alarm “High received optical power”
10. Set the “Upper optical threshold” attribute to the value Rx(dBm) obtained at step 3 + 1(dB)
11. Wait till the alarm “High received optical power” is cleared
12. Set the “Lower transmit power threshold” attribute with the value Tx(dBm) obtained at step 3 + 1(dB)

13. Wait for the alarm “Low transmit optical power”
14. Set the “Lower transmit power threshold” attribute with the value Tx(dBm) obtained at step 3 - 1(dB)
15. Wait till the alarm “Low transmit optical power” is cleared
16. Set the “Upper transmit power threshold” attribute with the value Tx(dBm) obtained at step 3 - 1(dB)
17. Wait for the alarm “High transmit optical power”
18. Set the “Upper transmit power threshold” attribute with the value Tx(dBm) obtained at step 3 + 1(dB)
19. Wait till the alarm “High transmit optical power” is cleared

OMCI Procedure Details

Refer to clause 4.3.

Pass/Fail Criteria

The test passes if the following are true, otherwise the test fails:

1. The ONU sends the Optical parameters at step 2
2. The value obtained at step 2 are within +/- 3dB of the value obtained at step 1 as per the relevant standard
3. The ONU tests and sends the Optical parameters at step 3
4. The value obtained at step 3 are within +/- 3dB of the value obtained at step 1 as per the relevant standard
5. The ONU responds successfully at step 4
6. The ONU sends “Low received optical power” alarm at step 5
7. The ONU responds successfully at step 6
8. The ONU sends an alarm message with the “Low received optical power” alarm bit cleared at step 7
9. The ONU responds successfully at step 8
10. The ONU sends “High received optical power” alarm at step 9
11. The ONU responds successfully at step 10
12. The ONU sends an alarm message with the “High received optical power” alarm bit cleared at step 11
13. The ONU responds successfully at step 12
14. The ONU sends “Low transmit optical power” alarm at step 13

15. The ONU responds successfully at step 14

16. The ONU sends an alarm message “Low transmit optical power” alarm bit cleared at step 15

17. The ONU responds successfully at step 16

18. The ONU sends “High transmit optical power” alarm at step 17

19. The ONU responds successfully at step 18

20. The ONU sends an alarm message “High transmit optical power” alarm bit cleared at step 19

Remarks

- None.

6.9.6 OMCI reboot with OMCI configuration persistence

Test Name

OMCI reboot with OMCI configuration persistence

Test Definition Number

ONU.6.9.6

Reference Document

ITU-T G.988 [6][7][8]

Test Type

Conformance

Test Requirement Type

Conditional Mandatory

If the OMCI reboot results in non-zero MIB data sync value, then perform this test.

Unit Under Test

ONU

Requirement Description

ITU-T G.988 Appendix I

Test Objective

Verify that the ONU is able to perform an OMCI reboot with OMCI configuration persistence

Test Configuration

1. The OLT Emulator and ONU are powered on and connected to ODN
2. The ONU under test has been activated by the OLT Emulator, has been ranged, and a GEM port for OMCI has been created as a result of ONU-ID assignment
3. The OLT Emulator has instructed the ONU to reset its MIB to its default values
4. The OLT Emulator configures through OMCI the ONU under test:
 - To support 1 traffic class (i.e., P-bit mapping)

- With 1 GEM port and 1 downstream queue
5. The Ethernet Traffic Generator and the OLT Emulator will be configured to transmit one flow of double-tagged Ethernet frames with the parameters in the next table. Also, GEM port mapping is shown

Upstream Direction																								
Traffic Stream	U Interface														R/S Interface									
	UNI	MAC DA	MAC SA	Outer VLAN Tag				Inner VLAN Tag				Ethertype	IP DA	IP SA	Outer VLAN Tag				Inner VLAN Tag			GEM	T-CONT	
	Port #	Value	Value	TPID	Pbits	DEI	VID	TPID	Pbits	CFI or DEI	VID	Value	Value	Value	TPID	Pbits	DEI	VID	TPID	Pbits	CFI or DEI	VID	Port #	Number
A	1	MAC1	MAC2	n/a	n/a	n/a	n/a	0x8100	CPbit1	n/a	CVID1	x	x	x	n/a	n/a	n/a	n/a	0x88A8	SPbit1	x	SVID1	GEM1	TCONT1

Downstream Direction																							
Traffic Stream	S/R Interface														U Interface								
	MAC DA	MAC SA	Outer VLAN Tag				Inner VLAN Tag				Ethertype	IP DA	IP SA	GEM	Outer VLAN Tag				Inner VLAN Tag			UNI	
	Value	Value	TPID	Pbits	DEI	VID	TPID	Pbits	CFI or DEI	VID	Value	Value	Value	Port #	TPID	Pbits	DEI	VID	TPID	Pbits	CFI or DEI	VID	Port #
B	MAC2	MAC1	n/a	n/a	n/a	n/a	0x88A8	SPbit1	x	SVID1	x	x	x	GEM1	n/a	n/a	n/a	n/a	0x8100	CPbit1	n/a	CVID1	1

Test Procedure

1. Select distinct random values for MAC address: MAC1, MAC2
2. Select distinct random values for CVID1 and SVID1 between 1 and 4094
3. Select distinct random values for CPbit1 and SPbit1 between 0 and 7
4. Cause the Traffic Generator to transmit the upstream and downstream traffic defined in test configuration step 5
5. Cause the OLT Emulator to send the GET MIB data sync OMCI message
6. Cause the OLT Emulator to send the OMCI message to reboot the ONU (The “Reboot” OMCI message of the “ONU-G” ME)
7. Cause the OLT Emulator to send the GET MIB data sync OMCI message
8. Cause the Traffic Generator to transmit the upstream and downstream traffic defined in test configuration step 5.

OMCI Procedure Details

Refer to clause 4.3.

Pass/Fail Criteria

1. All OMCI commands have success responses
2. The ONU is able to forward traffic in the upstream and downstream directions without any packet loss at step 4

3. The MIB data sync OMCI message reports the value resulting from the OMCI sequence at step 5
4. The ONU responds successfully to the “Reboot” OMCI message at step 6
5. No Dying Gasp is sent by the ONU at step 6
6. At step 7, the MIB data sync OMCI message reports the same value as measured at step 5
7. The ONU is able to forward traffic in upstream and downstream directions without any packet loss at step 8

Remarks

- None.

6.9.7 OMCI reboot without OMCI configuration persistence

Test Name

OMCI reboot without OMCI configuration persistence

Test Definition Number

ONU.6.9.7

Reference Document

ITU-T G.988 [6][7][8]

Test Type

Conformance

Test Requirement Type

Conditional Mandatory

If the OMCI reboot results in zero MIB data sync value, then perform this test.

Unit Under Test

ONU

Requirement Description**ITU-T G.988 Appendix I****Test Objective**

Verify that the ONU is able to perform an OMCI reboot without OMCI configuration persistence.

Test Configuration

1. The OLT Emulator and ONU are powered on and connected to ODN
2. The ONU under test has been activated by the OLT Emulator, has been ranged, and a GEM port for OMCI has been created as a result of ONU-ID assignment
3. The OLT Emulator has instructed the ONU to reset its MIB to its default values
4. The OLT Emulator configures through OMCI the ONU under test:
 - To support 1 traffic class (i.e., P-bit mapping)

- With 1 GEM port and 1 downstream queue
5. The Ethernet Traffic Generator and the OLT Emulator will be configured to transmit one flow of double-tagged Ethernet frames with the parameters in the next table. Also, GEM port mapping is shown

Upstream Direction																								
Traffic Stream	U Interface														R/S Interface									
	UNI	MAC DA	MAC SA	Outer VLAN Tag				Inner VLAN Tag				Ethertype	IP DA	IP SA	Outer VLAN Tag				Inner VLAN Tag			GEM	T-CONT	
	Port #	Value	Value	TPID	Pbits	DEI	VID	TPID	Pbits	CFI or DEI	VID	Value	Value	Value	TPID	Pbits	DEI	VID	TPID	Pbits	CFI or DEI	VID	Port #	Number
A	1	MAC1	MAC2	n/a	n/a	n/a	n/a	0x8100	CPbit1	n/a	CVID1	x	x	x	n/a	n/a	n/a	n/a	0x88A8	SPbit1	x	SVID1	GEM1	TCONT1

Downstream Direction																							
Traffic Stream	S/R Interface											U Interface											
	MAC DA	MAC SA	Outer VLAN Tag				Inner VLAN Tag				Ethertype	IP DA	IP SA	GEM	Outer VLAN Tag				Inner VLAN Tag				UNI
	Value	Value	TPID	Pbits	DEI	VID	TPID	Pbits	CFI or DEI	VID	Value	Value	Value	Port #	TPID	Pbits	DEI	VID	TPID	Pbits	CFI or DEI	VID	Port #
B	MAC2	MAC1	n/a	n/a	n/a	n/a	0x88A8	SPbit1	x	SVID1	x	x	x	GEM1	n/a	n/a	n/a	n/a	0x8100	CPbit1	n/a	CVID1	1

Test Procedure

1. Select distinct random values for MAC address: MAC1, MAC2
2. Select distinct random values for CVID1 and SVID1 between 1 and 4094
3. Select distinct random values for CPbit1 and SPbit1 between 0 and 7
4. Cause the Traffic Generator to transmit the upstream and downstream traffic defined in test configuration step 5
5. Cause the OLT Emulator to send the GET MIB data sync OMCI message
6. Cause the OLT Emulator to send the OMCI message to reboot the ONU (The “Reboot” OMCI message of the “ONU-G” ME)
7. Cause the OLT Emulator to send the GET MIB data sync OMCI message
8. Cause the OLT Emulator to send the OMCI message sequences to configure the ONU
9. Cause the Traffic Generator to transmit the upstream and downstream traffic defined in test configuration step 5

OMCI Procedure Details

Refer to clause 4.3.

Pass/Fail Criteria

1. All OMCI commands have success responses

2. The ONU is able to forward traffic in upstream and downstream directions without any packets lost at step 4
3. The MIB data sync OMCI message reports the value resulting from the OMCI sequence at step 5
4. The ONU responds successfully to the "Reboot" OMCI message at step 6
5. No Dying Gasp is sent by the ONU at step 6
6. The MIB data sync OMCI message reports the value 0 at step 7
7. The ONU is able to forward traffic in upstream and downstream directions without any packets lost after step 9

Remarks

- None.

6.9.8 OMCI Reset & MIB synchronization

Test Name

OMCI Reset & MIB synchronization

Test Definition Number

ONU.6.9.8

Reference Document

ITU-T G.988 [6][7][8]

Test Type

Conformance

Test Requirement Type

Mandatory

Unit Under Test

ONU

Requirement Description

ITU-T G.988 Appendix I

Test Objective

Verify that the ONU is able to perform an OMCI Reset (MIB data sync = 0 after reset)

Test Configuration

1. The OLT Emulator and ONU are powered on and connected to ODN
2. The ONU under test has been activated by the OLT Emulator, has been ranged, and a GEM port for OMCI has been created as a result of ONU-ID assignment
3. The OLT Emulator has instructed the ONU to reset its MIB to its default values
4. The Ethernet Traffic Generator and OLT Emulator will be configured to transmit one flow of double-tagged Ethernet frames with the parameters in the next tables. Also, GEM port mapping is shown

Upstream Direct bn																								
Traf # Stream	U Interface														R/S Interface									
	UNI	MAC DA	MAC SA	Outer VLAN Tag				Inner VLAN Tag				Ethertype	IP DA	IP SA	Outer VLAN Tag				Inner VLAN Tag				GEM	T-CONT
	Port #	Value	Value	TPID	Pbits	DEI	VID	TPID	Pbits	CFI or DEI	VID	Value	Value	Value	TPID	Pbits	DEI	VID	TPID	Pbits	CFI or DEI	VID	Port #	Number
A	1	MAC1	MAC2	n/a	n/a	n/a	n/a	0x8100	CPbits1	x	CVID1	x	x	x	n/a	n/a	n/a	n/a	0x88A8	SPbits1	x	SVID1	GEM1	TCONT1
B	1	MAC3	MAC4	n/a	n/a	n/a	n/a	0x8100	CPbits2	x	CVID2	x	x	x	n/a	n/a	n/a	n/a	0x88A8	SPbits2	x	SVID2	GEM2	TCONT2

Downstream Direct bn																							
Traf # Stream	S/R Interface														U Interface								
	MAC DA	MAC SA	Outer VLAN Tag				Inner VLAN Tag				Ethertype	IP DA	IP SA	GEM	Outer VLAN Tag				Inner VLAN Tag				UNI
	Value	Value	TPID	Pbits	DEI	VID	TPID	Pbits	CFI or DEI	VID	Value	Value	Value	Port #	TPID	Pbits	DEI	VID	TPID	Pbits	CFI or DEI	VID	Port #
C	MAC2	MAC1	n/a	n/a	n/a	n/a	0x88A8	0	x	SVID1	x	x	x	GEM1	n/a	n/a	n/a	n/a	0x8100	CPbits1	x	CVID1	1
D	MAC4	MAC3	n/a	n/a	n/a	n/a	0x88A8	0	x	SVID2	x	x	x	GEM2	n/a	n/a	n/a	n/a	0x88A8	CPbits2	x	CVID1	1

Note: x means that the value of the field is not taken into account during the test.

Test Procedure

1. Select distinct random values for MAC address: MAC1, MAC2, MAC3 and MAC4
2. Select distinct random values for CVID1, CVID2, SVID1 and SVID2 between 1 and 4094
3. Select distinct random values for CPbit1, CPbit2, SPbit1 and SPBit2 between 0 and 7
4. Cause the OLT Emulator to configure the ONU under test to support 1 traffic class, 1 GEM port and 1 Downstream Priority Queue, with the translation rules described for stream A (upstream) and C (downstream) in the table provided in test configuration step 4
5. Cause the OLT Emulator to send the GET MIB data sync OMCI message
6. Cause the Traffic Generator to transmit the upstream and downstream traffic defined in test configuration step 4
7. Cause the OLT Emulator to send the OMCI message MIB Reset the ONU
8. Cause the OLT Emulator to send the GET MIB data sync OMCI message
9. Cause the Traffic Generator to transmit the upstream and downstream traffic defined in test configuration step 4
10. Cause the OLT Emulator to configure the ONU under test to support 1 traffic class, 1 GEM port and 1 Downstream Priority Queue, with the translation rules described for stream B (upstream) & D (downstream) in the table provided in configuration step 4
11. Cause the Traffic Generator to transmit the upstream and downstream traffic defined in test configuration step 4

OMCI Procedure Details

Refer to clause 4.3.

Pass/Fail Criteria

1. All OMCI commands have success responses
2. The MIB data sync OMCI message reports the value resulting from the OMCI sequence at step 5
3. Traffic flow A is received at the OLT Emulator at step 6
4. Traffic flow C is received at the U-interface at step 6
5. Traffic flow B & D are not received at step 6
6. The ONU responds successfully to the "MIB Reset" OMCI message at step 7
7. The MIB data sync OMCI message reports the value 0 at step 8
8. No traffic is forwarded at step 10
9. Traffic flow B is received at the OLT Emulator at step 11
10. Traffic flow D is received at the U-interface at step 11
11. Traffic flow A & C are not received at step 11

Remarks

- None.

6.9.9 Use of Extended OMCI in a MIB Upload Using the Minimal Data Allocation Size

Test Name

Use of Extended OMCI in a MIB Upload Using the Minimal Data Allocation Size

Test Definition Number

ONU.6.9.9

Reference Document

BBF TR-280 [23]

BBF TR-280 Amendment 1 [24]

ITU-T G.988 [6][7][8]

Test Type

Conformance

Test Requirement Type

Conditionally Mandatory (test applies only to ONUs supporting the optional Extended OMCI Message format, as stipulated in section 4.3.3 of this test plan)

Unit Under Test

ONU

Requirement Description**ITU-T G.988 Annex A****BBF TR-280 Amendment 1**

- **R-89** The ONU MUST support Extended OMCI Message format if ME ONU2-G reports support of Extended OMCI Message format.

Test Objective

To verify that the ONU can perform a MIB upload using the extended OMCI format, using the minimal data allocation.

Test Configuration

1. ONU is powered off and connected to the ODN.
2. OLT Emulator is powered on, active and connected to the ODN.

3. The OLT Emulator should be configured to send the sequence of PLOAM and OMCI messages required to fulfill the ONU activation process, the OMCC establishment, MIB synchronization and MIB upload processes.
4. The OLT Emulator has been configured to use the OMCI Extended Message Set

Test Procedure

1. Power the ONU on.
2. Cause the OLT Emulator to establish the OMCI channel, that is, to activate a GEM port for OMCI.
3. Cause the OLT Emulator to provide the minimal data allocation size for the default allocation
4. Cause the OLT Emulator to perform a MIB Upload.

OMCI Procedure Details

Refer to clause 4.3.

Pass/Fail Criteria

The test passes if the following are true, otherwise the test fails:

1. After ONU activation and OMCC establishment, the ONU answers to all the OMCI messages sent by the OLT Emulator.
2. All the OMCI response messages are syntactically correct
3. The MIB Upload must complete correctly at step 4.

Remarks

- None.

6.9.10 Use of Extended OMCI in a MIB Upload with Maximum Upstream Bandwidth

Test Name

Use of Extended OMCI in a MIB Upload with Maximum Upstream Bandwidth

Test Definition Number

ONU.6.9.10

Reference Document

BBF TR-280 [23]

BBF TR-280 Amendment 1 [24]

ITU-T G.988 [6][7][8]

Test Type

Conformance

Test Requirement Type

Conditionally Mandatory (test applies only to ONUs supporting the optional Extended OMCI Message format, as stipulated in section 4.3.3 of this test plan).

Unit Under Test

ONU

Requirement Description

ITU-T G.988 Annex A

BBF TR-280 Amendment 1

- **R-89** The ONU MUST support Extended OMCI Message format if ME ONU2-G reports support of Extended OMCI Message format.

Test Objective

To verify that the ONU can perform a MIB upload using the extended OMCI, with the largest possible bandwidth allocation.

Test Configuration

1. ONU is powered off and connected to the ODN.
2. OLT Emulator is powered on, active and connected to the ODN.

3. The OLT Emulator should be configured to send the sequence of PLOAM and OMCI messages required to fulfill the ONU activation process, the OMCC establishment, MIB synchronization and MIB upload processes.
4. The OLT Emulator has been configured to use the OMCI Extended Message Set

Test Procedure

1. Power the ONU on.
2. Cause the OLT Emulator to establish the OMCI channel, that is, to activate a GEM port for OMCI.
3. Cause the OLT Emulator to provide the maximal possible bandwidth to the default allocation.
4. Cause the OLT Emulator to perform a MIB upload.

OMCI Procedure Details

Refer to clause 4.3.

Pass/Fail Criteria

The test passes if the following are true, otherwise the test fails:

1. After ONU activation and OMCC establishment, the ONU answers to all the OMCI messages sent by the OLT Emulator.
2. All the OMCI response messages are syntactically correct
3. The MIB Upload must complete correctly at step 4

Remarks

- None.

6.10 Software Image Download

6.10.1 Software Image Download, multiple window sizes, padded final window

Test Name

Software Image Download, multiple window sizes, padded final window

Test Definition Number

ONU.6.10.1

Reference Document

ITU-T G.988 [6][7][8]

Test Type

Conformance

Test Requirement Type

Mandatory

Unit Under Test

ONU

Requirement Description

ITU-T G.988 Appendix I

Test Objective

Verify the ONU is able to perform the software image download procedure under the following conditions:

- i. Multiple window sizes proposed by the OLT
- ii. OLT inserts padding final sections (if software image is not evenly divisible by the window size)

Test Configuration

1. ONU is powered and connected to ODN
2. ONU has been activated by the OLT Emulator, has been ranged, and a GEM port for OMCI has been created as a result of ONU-ID assignment.
3. The OLT Emulator has instructed the ONU to reset its MIB to factory default values.
4. ONU vendor has provided valid software image to use in testing.

Test Procedure

1. Note the software image size, in bytes, and record this value below.

2. Cause the OLT Emulator to perform a Get operation on both software image MEs. Note which software image is reported as active.
3. Cause the OLT Emulator to send the Start_Software_Download_cmd with the following attributes:
 - Software Instance: Opposite of image reported as active in step 2
 - Window Size: 32
 - Software Image Size: As noted above in step 1
4. Record the value of the ONU's chosen window size in the Start_Software_Download_resp message as "ONU chosen window size" below.
5. Divide the provided software image into sections of 31 bytes (The last section may be a partial section and should be padded with zeros). Record the number of sections below.
6. Group the software image sections into N windows, each made up of "ONU chosen window size 1" sections. If there are "empty sections" in the last window, these sections must be padded with zeros. Record the number of windows below.
7. Cause the OLT Emulator to send the first window of sections to the ONU, with the AR bit being set only for the last section, using the Download_Section_cmd.
8. Verify the ONU responses to the final Download_Section_cmd (indicated by the AR bit being set) with the Download_Section_resp. The response should indicate success.
9. Repeat steps 7 and 8 for each of the N windows.
10. Calculate the CRC-32 for the software image, according to ITU-T I.363.5.
11. Cause the OLT Emulator to send the End_Software_Download_cmd, with the CRC-32 calculated above.
12. Verify the ONU responds with the End_Software_Download_resp. The response should indicate success.
 - If the ONU responds with "Device Busy," wait 5 seconds and repeat steps 11 and 12. Repeat this delay no more than 23 times (120 seconds of total waiting time).
13. Cause the OLT Emulator to perform a Get operation on the software image instance that was the download target.
14. Verify the ONU reports the software image as Valid, Inactive, and Uncommitted.
15. Repeat steps 3 through 14 using an OLT window size of 16.
16. Repeat steps 3 through 14 using an OLT window size of 64.

OMCI Procedure Details

Refer to clause 4.3.

Pass/Fail Criteria

The test passes if the following are true, otherwise the test fails:

1. The ONU must indicate success in the response to the Start_Software_Download_cmd (procedure step 4).
2. The ONU must indicate success for each downloaded window (procedure step 8).

3. The ONU must indicate success in the final End_Software_Download_resp (procedure step 12). [The number of times the ONU responds with "Device Busy" does not impact this result, provided the 120 second timeout is not reached.]
4. The ONU must report the software image for the instance that was the download target as Valid, Inactive, and Uncommitted.

Remarks

Measured/calculated values used in testing:

- Software image size (bytes):
- OLT Window Size (integer): 32
 1. ONU chosen window size (integer):
 2. Number of sections per software image (integer):
 3. Number of windows per software image (integer):
- OLT Window Size (integer): 16
 1. ONU chosen window size (integer):
 2. Number of sections per software image (integer):
 3. Number of windows per software image (integer):
- OLT Window Size (integer): 64
 1. ONU chosen window size (integer):
 2. Number of sections per software image (integer):
 3. Number of windows per software image (integer):

6.10.2 Software Image Download, shortened final window

Test Name

Software Image Download, shortened final window

Test Definition Number

ONU.6.10.2

Reference Document

ITU-T G.988 [6][7][8]

Test Type

Conformance

Test Requirement Type

Mandatory

Unit Under Test

ONU

Requirement Description

ITU-T G.988 Appendix I

Test Objective

Verify the ONU is able to perform the software image download procedure under the following conditions:

- i. OLT shortens the final window (if software image is not evenly divisible by the window size) by setting the AR bit in the Download_Section_cmd for the final section of the software image.

Test Configuration

1. ONU is powered and connected to ODN
2. ONU has been activated by the OLT Emulator, has been ranged, and a GEM port for OMCI has been created as a result of ONU-ID assignment.
3. The OLT Emulator has instructed the ONU to reset its MIB to factory default values.
4. ONU vendor has provided valid software image to use in testing.

Test Procedure

1. Note the software image size, in bytes, and record this value below.
2. Cause the OLT Emulator to perform a *Get* operation on both software image MEs. Note which software image is reported as active.

3. Cause the OLT Emulator to send the Start_Software_Download_cmd with the following attributes:
 - Software Instance: Opposite of image reported as active in step 2
 - Window Size: 32
 - Software Image Size: As noted above in step 1
4. Record the value of the ONU's chosen window size in the Start_Software_Download_resp message as "ONU chosen window size 1" below.
5. Divide the provided software image into sections of 31 bytes (The last section may be a partial section, and should be padded with zeros).
6. Group the software image sections into N windows, each made up of "ONU chosen window size 1" sections. The last window is likely to have fewer sections than "full window," this window will be shortened by setting the AR bit in Download_Section_cmd for the final section of the software image.
7. Cause the OLT Emulator to send the first window of sections to the ONU, with the AR bit being set only for the last section, using the Download_Section_cmd.
8. Verify the ONU responses to the final Download_Section_cmd (indicated by the AR bit being set) with the Download_Section_resp. The response should indicate success.
9. Repeat steps 7 and 8 for each of the N windows.
10. Calculate the CRC-32 for the software image, according to ITU-T I.363.5.
11. Cause the OLT Emulator to send the End_Software_Download_cmd, with the CRC-32 calculated above.
12. Verify the ONU responds with the End_Software_Download_resp. The response should indicate success.
 - If the ONU responds with "Device Busy," wait 5 seconds and repeat steps 11 and 12. Repeat this delay no more than 23 times (120 seconds of total waiting time).
13. Cause the OLT Emulator to perform a Get operation on the software image instance that was the download target.
14. Verify the ONU reports the software image as Valid, Inactive, and Uncommitted.

OMCI Procedure Details

Refer to clause 4.3.

Pass/Fail Criteria

The test passes if the following are true, otherwise the test fails:

1. The ONU must indicate success in the response to the Start_Software_Download_cmd (procedure step 4).
2. The ONU must indicate success for each downloaded window (procedure step 8).
3. The ONU must indicate success in the final End_Software_Download_resp (procedure step 12). [The number of times the ONU responds with "Device Busy" does not impact this result, provided the 120 second timeout is not reached.]
4. The ONU must report the software image for the instance that was the download target as Valid, Inactive, and Uncommitted.

Remarks

Measured/calculated values used in testing:

1. OLT Window Size (integer): 32
2. Software image size (bytes):
3. ONU chosen window size (integer):
4. Number of sections per software image (integer):
5. Number of windows per software image (integer):

6.10.3 Failed Software Image Download, missing section

Test Name

Failed Software Image Download, missing section

Test Definition Number

ONU.6.10.3

Reference Document

ITU-T G.988 [6][7][8]

Test Type

Conformance

Test Requirement Type

Mandatory

Unit Under Test

ONU

Requirement Description

ITU-T G.988 Appendix I

Test Objective

Verify the ONU is able to detect a gap in the section number within the Download_Section_cmd, and report the error to the OLT.

Test Configuration

1. ONU is powered and connected to ODN.
2. ONU has been activated by the OLT Emulator, has been ranged, and a GEM port for OMCI has been created as a result of ONU-ID assignment.
3. The OLT Emulator has instructed the ONU to reset its MIB to factory default values.
4. ONU vendor has provided valid software image to use in testing.

Test Procedure

1. Note the software image size, in bytes, and record this value below.
2. Cause the OLT Emulator to perform a *Get* operation on both software image MEs. Note which software image is reported as active.
3. Cause the OLT Emulator to send the Start_Software_Download_cmd with the following attributes:
 - Software Instance: Opposite of image reported as active in step 2

- Window Size: 32
 - Software Image Size: As noted above in step 1
4. Record the value of the ONU's chosen window size in the Start_Software_Download_resp message as "ONU chosen window size" below.
 5. Divide the provided software image into sections of 31 bytes (The last section may be a partial section, and should be padded with zeros).
 6. Group the software image sections into N windows, each made up of "ONU chosen window size 1" sections. Only the first window will be used in this test.
 7. Cause the OLT Emulator to download the first section of the first window, setting the "Download Section Number" to 0, using the Download_Section_cmd.
 8. Cause the OLT Emulator to download the third section of the first window, setting the "Download Section Number" to 2 (this is skipping the second section of the window), using the Download_Section_cmd.
 9. Cause the OLT Emulator to download the remaining sections of the window, setting the AR bit for the last section of the window.
 10. Verify the ONU responds with the Download_Section_resp, indicating a failure for the window.
 11. Cause the OLT Emulator to cancel the software image download by sending the End_Software_Download_cmd. The value of the CRC-32 is not important, as the download is being terminated in a failure mode.
 12. Verify responds with the End_Softward_Download_resp, indicating a failure.

OMCI Procedure Details

Refer to clause 4.3.

Pass/Fail Criteria

The test passes if the following are true, otherwise the test fails:

1. The ONU must indicate success in the response to the Start_Software_Download_cmd (procedure step 4).
2. The ONU must indicate a failure for the first downloaded window (procedure step 8).
3. The ONU must indicate a failure in the final End_Software_Download_resp (procedure step 12).

Remarks

Measured/calculated values used in testing:

- OLT Window Size (integer): 32
- Software image size (bytes):
- ONU chosen window size (integer):
- Number of sections per software image (integer):
- Number of windows per software image (integer):

6.10.4 Failed Software Image Download, incorrect section CRC

Test Name

Failed Software Image Download, incorrect section CRC

Test Definition Number

ONU.6.10.4

Reference Document

ITU-T G.988 [6][7][8]

Test Type

Conformance

Test Requirement Type

Mandatory

Unit Under Test

ONU

Requirement Description

ITU-T G.988 Appendix I

Test Objective

Verify the ONU is able to detect and report an incorrect CRC for an OMCI message transporting a Download_Section_cmd.

Test Configuration

1. ONU is powered and connected to ODN.
2. ONU has been activated by the OLT Emulator, has been ranged, and a GEM port for OMCI has been created as a result of ONU-ID assignment.
3. The OLT Emulator has instructed the ONU to reset its MIB to factory default values.
4. ONU vendor has provided valid software image to use in testing.

Test Procedure

1. Note the software image size, in bytes, and record this value below.
2. Cause the OLT Emulator to perform a *Get* operation on both software image MEs. Note which software image is reported as active.
3. Cause the OLT Emulator to send the Start_Software_Download_cmd with the following attributes:

4. Software Instance: Opposite of image reported as active in step 2
5. Window Size: 32
6. Software Image Size: As noted above in step 1
7. Record the value of the ONU's chosen window size in the Start_Software_Download_resp message as "ONU chosen window size" below.
8. Divide the provided software image into sections of 31 bytes (The last section may be a partial section, and should be padded with zeros).
9. Group the software image sections into N windows, each made up of "ONU chosen window size 1" sections. Only the first window will be used in this test.
10. Cause the OLT Emulator to download the first section of the first window, using the Download_Section_cmd.
11. Cause the OLT Emulator to download the second section of the first window, using the Download_Section_cmd. Before transmitting the OMCI message, arbitrarily invert two of the bits in the OMCI message CRC field.
12. Cause the OLT Emulator to download the remaining sections of the window, setting the AR bit for the last section of the window.
13. Verify the ONU responds with the Download_Section_resp, indicating a failure for the window.
14. Cause the OLT Emulator to cancel the software image download by sending the End_Software_Download_cmd. The value of the CRC-32 is not important, as the download is being terminated in a failure mode.
15. Verify responds with the End_Software_Download_resp, indicating a failure.

OMCI Procedure Details

Refer to clause 4.3.

Pass/Fail Criteria

The test passes if the following are true, otherwise the test fails:

1. The ONU must indicate success in the response to the Start_Software_Download_cmd (procedure step 7).
2. The ONU must indicate a failure for the first downloaded window (procedure step 13).
3. The ONU must indicate a failure in the final End_Software_Download_resp (procedure step 15).

Remarks

Measured/calculated values used in testing:

- OLT Window Size (integer): 32
- Software image size (bytes):
- ONU chosen window size (integer):
- Number of sections per software image (integer):
- Number of windows per software image (integer):

6.10.5 Failed Software Image Download, incorrect software image CRC

Test Name

Failed Software Image Download, incorrect software image CRC

Test Definition Number

ONU.6.10.5

Reference Document

ITU-T G.988 [6][7][8]

Test Type

Conformance

Test Requirement Type

Mandatory

Unit Under Test

ONU

Requirement Description

ITU-T G.988 Appendix I

Test Objective

Verify the ONU is able to detect and report an incorrect CRC for the complete software image after the OLT issues the End_Software_Download_command. It is assumed the software image was transferred to the ONU without error.

Test Configuration

1. ONU is powered and connected to ODN.
2. ONU has been activated by the OLT Emulator, has been ranged, and a GEM port for OMCI has been created as a result of ONU-ID assignment.
3. The OLT Emulator has instructed the ONU to reset its MIB to factory default values.
4. ONU vendor has provided valid software image to use in testing.
5. ONU must have passed tests ONU-6.10.1 and ONU-6.10.2.

Test Procedure

1. Note the software image size, in bytes, and record this value below.
2. Cause the OLT Emulator to perform a *Get* operation on both software image MEs. Note which software image is reported as active.

3. Cause the OLT Emulator to send the Start_Software_Download_cmd with the following attributes:
 - Software Instance: Opposite of image reported as active in step 2
 - Window Size: 32
 - Software Image Size: As noted above in step 1
4. Record the value of the ONU's chosen window size in the Start_Software_Download_resp message as "ONU chosen window size" below.
5. Divide the provided software image into sections of 31 bytes (The last section may be a partial section, and should be padded with zeros).
6. Group the software image sections into N windows, each made up of "ONU chosen window size 1" sections.
7. Cause the OLT Emulator to download the each window, using the Download_Section_cmd.
8. Verify the ONU responds with the Download_Section_resp, indicating success for each window. The last window may be padded or shorten as in tests ONU-6.10.1 or ONU-6.10.2.
9. Cause the OLT Emulator to complete the software image download by sending the End_Software_Download_cmd. Ensure the CRC-32 value for the software image transmitted in the OMCI is incorrect.
10. Verify responds with the End_Software_Download_resp, indicating a failure.
 - If the ONU responds with "Device Busy," wait 5 seconds and repeat steps 9 and 10. Repeat this delay no more than 23 times (120 seconds of total waiting time).
11. Cause the OLT Emulator to perform a Get operation on the software image instance that was the download target.
12. Verify the ONU reports the software image as Invalid, Inactive, and Uncommitted.

OMCI Procedure Details

Pass/Fail Criteria

The test passes if the following are true, otherwise the test fails:

1. The ONU must indicate success in the response to the Start_Software_Download_command (procedure step 4).
2. The ONU must indicate success for the each downloaded window section (procedure step 8).
3. The ONU must indicate a failure in the final End_Software_Download_response (procedure step 10).
4. The ONU must report the software image for the instance that was the download target as Invalid, Inactive, and Uncommitted.

Remarks

Measured/calculated values used in testing:

- OLT Window Size (integer): 32
- Software image size (bytes):
- ONU chosen window size (integer):

- Number of sections per software image (integer):
- Number of windows per software image (integer):

6.10.6 Test Case Reserved For Future Use

6.10.7 Activate uncommitted software image

Test Name

Activate uncommitted software image

Test Definition Number

ONU.6.10.7

Reference Document

ITU-T G.988 [6][7][8]

Test Type

Conformance

Test Requirement Type

Mandatory

Unit Under Test

ONU

Requirement Description**ITU-T G.988 Appendix I****Test Objective**

This test verifies the ONU is able to activate an uncommitted, valid software image, which may have been newly downloaded to the ONU (outside the scope of this test). Once the uncommitted software image is running, the ONU is power cycled to ensure it falls back to the committed software image.

Test Configuration

1. ONU is powered and connected to ODN
2. ONU has been activated by the OLT Emulator, has been ranged, and a GEM port for OMCI has been created as a result of ONU-ID assignment.
3. The OLT Emulator has instructed the ONU to reset its MIB to factory default values.
4. ONU has two valid software images loaded, one must be committed and active, the other must be uncommitted, and inactive. (This may require the OLT Emulator to download a new, valid software image to the ONU).

Test Procedure

1. Cause the OLT Emulator to perform a *Get* operation on both software image MEs. Note which software images are reported as committed, active, and valid.
2. Verify the inactive image is also listed as valid, uncommitted.

3. Cause the OLT Emulator to send the `Activate_Image_cmd` for the image reported as valid, uncommitted, and inactive.
4. Verify the ONU responds with `Activate_Image_resp`, indicating success.
5. Wait for the ONU to load the new software image (this may cause the ONU to reboot).
6. Cause the OLT Emulator to perform a `Get` operation on both software image MEs.
7. Verify the newly activated image is reported as active and uncommitted.
8. Power cycle the ONU (this must be a hard power cycle, intended to simulate a watchdog timer reboot).
9. Wait for the ONU to complete booting and loading its software.
10. Cause the OLT Emulator to perform a `Get` operation on both software image MEs.
11. Verify the software image reported in step 1 is listed as active and committed.
12. Verify the second software image is reported as valid, inactive, and uncommitted.

OMCI Procedure Details

Refer to clause 4.3.

Pass/Fail Criteria

The test passes if the following are true, otherwise the test fails:

1. The ONU must load the activated image after step 4.
2. The ONU must report the active image as valid, active, and uncommitted in step 7.
3. After the power cycle, the ONU must be running the original software image that was reported as committed and active in step 1.

Remarks

- None.

6.10.8 Commit software image

Test Name

Commit software image

Test Definition Number

ONU.6.10.8

Reference Document

ITU-T G.988 [6][7][8]

Test Type

Conformance

Test Requirement Type

Mandatory

Unit Under Test

ONU

Requirement Description

ITU-T G.988 Appendix I

Test Objective

This test verifies the ONU is able to commit a valid software image.

Test Configuration

1. ONU is powered and connected to ODN
2. ONU has been activated by the OLT Emulator, has been ranged, and a GEM port for OMCI has been created as a result of ONU-ID assignment.
3. The OLT Emulator has instructed the ONU to reset its MIB to factory default values.
4. ONU has two valid software images loaded, one must be committed and active, the other must be uncommitted, and inactive. Note: This may require the OLT Emulator to download a new, valid software image to the ONU.
5. ONU has passed test ONU-6.10.7.

Test Procedure

1. Cause the OLT Emulator to perform a *Get* operation on both software image MEs. Note which software images are reported as committed, active, and valid.

2. Verify the inactive image is also listed as valid, uncommitted.
3. Cause the OLT Emulator to send the `Activate_Image_cmd` for the image reported as valid, uncommitted, and inactive.
4. Verify the ONU responds with `Activate_Image_resp`, indicating success.
5. Wait for the ONU to load the new software image (this may cause the ONU to reboot).
6. Cause the OLT Emulator to perform a `Get` operation on both software image MEs.
7. Verify the newly activated image is reported as active and uncommitted.
8. Cause the OLT Emulator to send the `Commit_Image_cmd` for the currently active software image.
9. Verify the ONU responds with the `Commit_Image_resp`, indicating success.
10. Cause the OLT Emulator to perform a `Get` operation on both software image MEs.
11. Verify the activated image is reported as active and committed.

OMCI Procedure Details

Refer to clause 4.3.

Pass/Fail Criteria

The test passes if the following are true, otherwise the test fails:

1. The ONU must load the activated image after step 4.
2. The ONU must report the active image as valid, active, and uncommitted in step 7.
3. The ONU must report the active image as valid, active, and committed in step 11.

Remarks

- None.

6.10.9 Use of Extended OMCI in a Software Download with the Minimal and Variable Section Size

Test Name

Use of Extended OMCI in a Software Download with the Minimal and Variable Section Size

Test Definition Number

ONU.6.10.9

Reference Document

BBF TR-280 [23]

BBF TR-280 Amendment 1 [24]

ITU-T G.988 [6][7][8]

Test Type

Conformance

Test Requirement Type

Conditionally Mandatory (test applies only to ONUs supporting the optional Extended OMCI Message format, as stipulated in section 4.3.3 of this test plan)

Unit Under Test

ONU

Requirement Description**ITU-T G.988 Annex A****BBF TR-280 Amendment 1**

- **R-89** The ONU MUST support Extended OMCI Message format if ME ONU2-G reports support of Extended OMCI Message format.

Test Objective

To verify that the ONU can perform a Software Download using the extended OMCI format, with minimal and variable section size.

Test Configuration

1. ONU is powered and connected to ODN
2. ONU has been activated by the OLT Emulator, has been ranged, and a GEM port for OMCI has been created as a result of ONU-ID assignment.

3. The OLT Emulator has instructed the ONU to reset its MIB to factory default values.
4. ONU vendor has provided valid software image to use in testing.
5. The OLT Emulator has been configured to use the OMCI Extended Message Set.
6. Note the software image size, in bytes, hereafter referred as I.
7. Select a Main Sector Size: S as an integer random value in the range [35, 1964]. Let Q be the quotient of the euclidian division I/S and R be the remainder of this division, i.e., $(I - (Q*S))$.
8. Divide the provided software image into the following parts
 - an "Initial Download" part made of a number of $A=(S+R)/2$ sections of 1 byte,
 - a "Main Download" part made of a number of $B=\max(0, (Q-1))$ sections of S bytes,
 - a "Final Download" part made of a number of $C= (I - B*S - A)$ sections of 1 byte.These parts will be downloaded sequentially in this order.

Test Procedure

1. referred Cause the OLT Emulator to perform a Get operation on both software image MEs. Note which software image is reported as active.
2. Cause the OLT Emulator to send the Start_Software_Download_cmd with the following attributes:
 - Software Instance: Opposite of image reported as active in step 2
 - Window Size: 32
 - Software Image Size: As noted above in step 1
3. Record the value of the ONU's chosen window size in the Start_Software_Download_resp message as "ONU chosen window size" below.
4. Group the software image sections into N windows, each made up of "ONU chosen window size" sections. The last window is likely to have fewer sections than "full window," this window will be shortened by setting the AR bit in Download_Section_cmd for the final section of the software image.
5. Cause the OLT Emulator to send the first window of sections to the ONU, with the AR bit being set only for the last section, using the Download_Section_cmd.

6. Verify the ONU responses to the final Download_Section_cmd (indicated by the AR bit being set) with the Download_Section_resp. The response should indicate success.
7. Repeat steps 7 and 8 for each of the N windows.
8. Calculate the CRC-32 for the software image, according to ITU-T I.363.5.
9. Cause the OLT Emulator to send the End_Software_Download_cmd, with the CRC-32 calculated above.
10. Verify the ONU responds with the End_Software_Download_resp. The response should indicate success.
 - If the ONU responds with “Device Busy,” wait 5 seconds and repeat steps 11 and 12. Repeat this delay no more than 23 times (120 seconds of total waiting time).
11. Cause the OLT Emulator to perform a Get operation on the software image instance that was the download target.
12. Verify the ONU reports the software image as Valid, Inactive, and Uncommitted.

OMCI Procedure Details

Refer to clause 4.3.

Pass/Fail Criteria

The test passes if the following are true, otherwise the test fails:

1. The ONU must indicate success in the response to the Start_Software_Download_cmd (procedure step 2).
2. The ONU must indicate success for each downloaded window (procedure step 5 and step 6).
3. The ONU must indicate success in the final End_Software_Download_resp (procedure step 10). [The number of times the ONU responds with “Device Busy” does not impact this result, provided the 120 second timeout is not reached.]
4. The ONU must report the software image for the instance that was the download target as Valid, Inactive, and Uncommitted.

Remarks

- None.

6.10.10 Use of Extended OMCI in a Software Download using the OMCI Maximum Message Size

Test Name

Use of Extended OMCI in a Software Download using the OMCI Maximum Message Size

Test Definition Number

ONU.6.10.10

Reference Document

BBF TR-280 [23]

BBF TR-280 Amendment 1 [24]

ITU-T G.988 [6][7][8]

Test Type

Conformance

Test Requirement Type

Conditionally Mandatory (test applies only to ONUs supporting the optional Extended OMCI Message format, as stipulated in section 4.3.3 of this test plan)

Unit Under Test

ONU

Requirement Description

ITU-T G.988 Annex A

BBF TR-280 Amendment 1

- **R-89** The ONU MUST support Extended OMCI Message format if ME ONU2-G reports support of Extended OMCI Message format.

Test Objective

To verify that the ONU can perform a Software Download using the extended OMCI format, using the OMCI max message size

Test Configuration

1. ONU is powered and connected to ODN
2. ONU has been activated by the OLT Emulator, has been ranged, and a GEM port for OMCI has been created as a result of ONU-ID assignment.

3. The OLT Emulator has instructed the ONU to reset its MIB to factory default values.
4. ONU vendor has provided valid software image to use in testing.
5. The OLT Emulator has been configured to use the OMCI Extended Message Set

Test Procedure

1. Note the software image size, in bytes, and record this value below.
2. Cause the OLT Emulator to perform a Get operation on both software image MEs. Note which software image is reported as active.
3. Cause the OLT Emulator to send the Start_Software_Download_cmd with the following attributes:
 - Software Instance: Opposite of image reported as active in step 2
 - Window Size: 32
 - Software Image Size: As noted above in step 1
4. Record the value of the ONU's chosen window size in the Start_Software_Download_resp message as "ONU chosen window size" below.
5. Divide the provided software image into sections of 1964 bytes (The last section may be a partial section, and must be adjusted to the content).
6. Group the software image sections into N windows, each made up of "ONU chosen window size 1" sections. The last window is likely to have fewer sections than "full window," this window will be shortened by setting the AR bit in Download_Section_cmd for the final section of the software image.
7. Cause the OLT Emulator to send the first window of sections to the ONU, with the AR bit being set only for the last section, using the Download_Section_cmd.
8. Verify the ONU responses to the final Download_Section_cmd (indicated by the AR bit being set) with the Download_Section_resp. The response should indicate success.
9. Repeat steps 7 and 8 for each of the N windows.
10. Calculate the CRC-32 for the software image, according to ITU-T I.363.5.
11. Cause the OLT Emulator to send the End_Software_Download_cmd, with the CRC-32 calculated above.
12. Verify the ONU responds with the End_Software_Download_resp. The response should indicate success.

- If the ONU responds with “Device Busy,” wait 5 seconds and repeat steps 11 and 12. Repeat this delay no more than 23 times (120 seconds of total waiting time).
13. Cause the OLT Emulator to perform a Get operation on the software image instance that was the download target.
 14. Verify the ONU reports the software image as Valid, Inactive, and Uncommitted.

OMCI Procedure Details

Refer to clause 4.3.

Pass/Fail Criteria

The test passes if the following are true, otherwise the test fails:

1. The ONU must indicate success in the response to the Start_Software_Download_cmd (procedure step 4).
2. The ONU must indicate success for each downloaded window (procedure step 8).
3. The ONU must indicate success in the final End_Software_Download_resp (procedure step 12). [The number of times the ONU responds with “Device Busy” does not impact this result, provided the 120 second timeout is not reached.]
4. The ONU must report the software image for the instance that was the download target as Valid, Inactive, and Uncommitted.

Remarks

- None.

6.10.11 Use of Extended OMCI in a Software Download with a 33 bytes OMCI payload size

Test Name

Use of Extended OMCI in a Software Download with a 33 bytes OMCI payload size

Test Definition Number

ONU.6.10.11

Reference Document

BBF TR-280 [23]

BBF TR-280 Amendment 1 [24]

ITU-T G.988 [6][7][8]

Test Type

Conformance

Test Requirement Type

Conditionally Mandatory (test applies only to ONUs supporting the optional Extended OMCI Message format, as stipulated in section 4.3.3 of this test plan)

Unit Under Test

ONU

Requirement Description**ITU-T G.988 Annex A****BBF TR-280 Amendment 1**

- **R-89** The ONU MUST support Extended OMCI Message format if ME ONU2-G reports support of Extended OMCI Message format.

Test Objective

To verify that the ONU can perform a Software Download using the extended OMCI format, using a 33 bytes OMCI payload size.

Test Configuration

1. ONU is powered and connected to ODN.
2. ONU has been activated by the OLT Emulator, has been ranged, and a GEM port for OMCI has been created as a result of ONU-ID assignment.

3. The OLT Emulator has instructed the ONU to reset its MIB to factory default values.
4. ONU vendor has provided valid software image to use in testing.
5. The OLT Emulator has been configured to use the OMCI Extended Message Set.
6. The OLT Emulator has been configured to use a maximum OMCI payload size of 33 bytes.

Test Procedure

1. Note the software image size, in bytes, and record this value below.
2. Cause the OLT Emulator to perform a Get operation on both software image MEs. Note which software image is reported as active.
3. Cause the OLT Emulator to send the Start_Software_Download_cmd with the following attributes:
 - Software Instance: Opposite of image reported as active in step 2
 - Window Size: 32
 - Software Image Size: As noted above in step 1
4. Record the value of the ONU's chosen window size in the Start_Software_Download_resp message as "ONU chosen window size" below.
5. Divide the provided software image into sections of 33 bytes (The last section may be a partial section, and must be adjusted to the content).
6. Group the software image sections into N windows, each made up of "ONU chosen window size 1" sections. The last window is likely to have fewer sections than "full window," this window will be shortened by setting the AR bit in Download_Section_cmd for the final section of the software image.
7. Cause the OLT Emulator to send the first window of sections to the ONU, with the AR bit being set only for the last section, using the Download_Section_cmd.
8. Verify the ONU responses to the final Download_Section_cmd (indicated by the AR bit being set) with the Download_Section_resp. The response should indicate success.
9. Repeat steps 7 and 8 for each of the N windows.
10. Calculate the CRC-32 for the software image, according to ITU-T I.363.5.
11. Cause the OLT Emulator to send the End_Software_Download_cmd, with the CRC-32 calculated above.

12. Verify the ONU responds with the End_Software_Download_resp. The response should indicate success.
 - If the ONU responds with “Device Busy,” wait 5 seconds and repeat steps 11 and 12. Repeat this delay no more than 23 times (120 seconds of total waiting time).
13. Cause the OLT Emulator to perform a Get operation on the software image instance that was the download target.
14. Verify the ONU reports the software image as Valid, Inactive, and Uncommitted.

OMCI Procedure Details

Refer to clause 4.3.

Pass/Fail Criteria

The test passes if the following are true, otherwise the test fails:

1. The ONU must indicate success in the response to the Start_Software_Download_cmd (procedure step 4).
2. The ONU must indicate success for each downloaded window (procedure step 8).
3. The ONU must indicate success in the final End_Software_Download_resp (procedure step 12). [The number of times the ONU responds with “Device Busy” does not impact this result, provided the 120 second timeout is not reached.]
4. The ONU must report the software image for the instance that was the download target as Valid, Inactive, and Uncommitted.

Remarks

- None.

6.11 Circuit Packs

6.11.1 Test Case Reserved For Future Use

6.11.2 Test Case Reserved For Future Use

6.11.3 Cardholder or port mapping package for integrated ONU

Test Name

Cardholder or port mapping package for integrated ONU

Test Definition Number

ONU.6.11.3

Reference Document

ITU-T G.988 [6][7][8]

Test Type

Conformance

Test Requirement Type

Conditionally Mandatory (integrated ONU devices)

Unit Under Test

ONU

Requirement Description

ITU-T G.988 Appendix I

Test Objective

To verify that the ONU is able to instantiate the cardholder or port mapping package without any configuration coming from the OLT

Test Configuration

1. OLT Emulator and ONU under test are connected to the ODN.
2. ONU under test is power off
3. ONU activation and OMCC establishment processes have been successfully completed.

Test Procedure

1. Power on the ONU
2. Wait the end of the bring up process
3. With the OLT Emulator sends a "MIB Upload" message

OMCI Procedure Details

Refer to clause 4.3.

Pass/Fail Criteria

The test passes if the following are true, otherwise the test fails:

1. The ONU sends the cardholder or port mapping package information during the MIB upload, at step 3

Remarks

- None.

6.11.4 Test Case Reserved For Future Use

6.11.5 Test Case Reserved For Future Use

6.11.6 Test Case Reserved For Future Use

6.12 TR-280 Other

6.12.1 Dying Gasp Emission

Test Name

Dying Gasp Emission

Test Definition Number

ONU.6.12.1

Reference Document

BBF TR-280 [23]

ITU-T G.988 [6][7][8]

Test Type

Conformance

Test Requirement Type

Mandatory

Unit Under Test

ONU

Requirement Description**BBF TR-280**

- **R-44** The ONU MUST send a Dying Gasp alarm in response to electrical disconnection and OLT MUST report it.

Test Objective

Verify that the ONU is able to send Dying Gasp alarm in response to electrical disconnection

Test Configuration

1. OLT Emulator and ONU under test are powered and connected to ODN
2. ONU under test has been activated by the OLT Emulator, has been ranged, and a GEM port for OMCI has been created as a result of ONU-ID assignment.

Test Procedure

1. Cause an electrical disconnection at the ONU power socket.
2. For G-PON ONUs, wait for the reception of the “Dying Gasp” PLOAM messages. For XGS-PON ONUs and XG-PON ONUs, wait for the “Dying Gasp” bit in the FS Header at OAM layer.
3. Connect back the ONU power socket and wait till the ONU is up and running.
4. If a power button is available on the ONU, manually power off the ONU using the power button
5. If a power button is available on the ONU, for G-PON ONUs, wait for the reception of the “Dying Gasp” PLOAM. For XGS-PON ONUs and XG-PON ONUs, wait for the “Dying Gasp” bit in the FS Header at OAM layer.

OMCI Procedure Details

Refer to clause 4.3.

Pass/Fail Criteria

The test passes if the following are true, otherwise the test fails:

1. At step 2,
 - a. for G-PON ONUs, the ONU sends at least three “Dying Gasp” PLOAM messages.
 - b. for XGS-PON ONUs and XG-PON ONUs, the ONU set the “Dying Gasp” bit in the FS Header at OAM layer.
2. At step 5, if a power button is available on the ONU,
 - a. for G-PON ONUs, the ONU sends at least three “Dying Gasp” PLOAM messages.
 - b. for XGS-PON ONUs and XG-PON ONUs, the ONU sets the “Dying Gasp” bit in the FS Header at OAM layer.

Remarks

- None.

6.12.2 Create and Modify Configuration

Test Name

Create and Modify Configuration

Test Definition Number

ONU.6.12.2

Reference Document

BBF TR-280 [23]

BBF TR-280 Amendment 1 [24]

ITU-T G.988 [6][7][8]

Test Type

Conformance

Test Requirement Type

Mandatory

Unit Under Test

ONU

Requirement Description

BBF TR-280 Amendment 1

- **R-90** The ONU MUST support traffic class deletion (traffic class as described in TR-156 Section 5) without causing any reboot, or MIB reset.
- **R-91** The ONU MUST support the deletion of a traffic class (traffic class as described in TR-156 Section 5) without causing any packet loss on existing traffic flows from other traffic classes.
- **R-92** The ONU MUST support traffic class addition (traffic class as described in TR-156 Section 5) without causing any reboot, or MIB reset.
- **R-93** The ONU MUST support the addition of a traffic class (traffic class as described in TR-156 Section 5) without causing any packet loss on existing traffic flows from other traffic classes when the addition does not cause any congestion in the ONU.

Test Objective

Verify that the ONU is able to create a service and then modify the service.

Test Configuration

1. OLT Emulator and ONU under test are powered and connected to ODN
2. ONU under test has been activated by the OLT Emulator, has been ranged, and a GEM port for OMCI has been created as a result of ONU-ID assignment.
3. The OLT Emulator configures through OMCI the ONU under test:
 - To support 1 traffic class (i.e., P-bit mapping)
 - With 1 GEM port and 1 downstream queue,
4. The Ethernet Traffic Generator and the OLT Emulator will be configured to transmit one flow of double-tagged Ethernet frames with the parameters in the next table. Also, GEM port mapping is shown

Configuration 1

Upstream Direction																								
Traffic Stream	U Interface														R/S Interface									
	UNI	MAC DA	MAC SA	Outer VLAN Tag				Inner VLAN Tag			Ethertype	IP DA	IP SA	Outer VLAN Tag				Inner VLAN Tag			GEM	T-CONT		
	Port #	Value	Value	TPID	Pbits	DEI	VID	TPID	Pbits	CFI or DEI	VID	Value	Value	Value	TPID	Pbits	DEI	VID	TPID	Pbits	CFI or DEI	VID	Port #	Number
A	1	MAC1	MAC2	n/a	n/a	n/a	n/a	0x8100	CPbit1	n/a	CVID1	x	x	x	n/a	n/a	n/a	n/a	0x88A8	SPbit1	x	SVID1	GEM1	TCONT1

Downstream Direction																							
Traffic Stream	S/R Interface													U Interface									
	MAC DA	MAC SA	Outer VLAN Tag				Inner VLAN Tag			Ethertype	IP DA	IP SA	GEM	Outer VLAN Tag				Inner VLAN Tag			UNI		
	Value	Value	TPID	Pbits	DEI	VID	TPID	Pbits	CFI or DEI	VID	Value	Value	Value	Port #	TPID	Pbits	DEI	VID	TPID	Pbits	CFI or DEI	VID	Port #
B	MAC2	MAC1	n/a	n/a	n/a	n/a	0x88A8	SPbit1	x	SVID1	x	x	x	GEM1	n/a	n/a	n/a	n/a	0x8100	CPbit1	n/a	CVID1	1

Configuration 2

Upstream Direction																								
Traffic Stream	U Interface														R/S Interface									
	UNI	MAC DA	MAC SA	Outer VLAN Tag				Inner VLAN Tag			Ethertype	IP DA	IP SA	Outer VLAN Tag				Inner VLAN Tag			GEM	T-CONT		
	Port #	Value	Value	TPID	Pbits	DEI	VID	TPID	Pbits	CFI or DEI	VID	Value	Value	Value	TPID	Pbits	DEI	VID	TPID	Pbits	CFI or DEI	VID	Port #	Number
C	1	MAC3	MAC4	n/a	n/a	n/a	n/a	0x8100	CPbit2	n/a	CVID2	x	x	x	n/a	n/a	n/a	n/a	0x88A8	SPbit2	x	SVID2	GEM1	TCONT1

Downstream Direction																							
Traffic Stream	S/R Interface														U Interface								
	MAC DA	MAC SA	Outer VLAN Tag				Inner VLAN Tag				Ethertype	IP DA	IP SA	GEM	Outer VLAN Tag				Inner VLAN Tag			UNI	
	Value	Value	TPID	Pbits	DEI	VID	TPID	Pbits	CFI or DEI	VID	Value	Value	Value	Port #	TPID	Pbits	DEI	VID	TPID	Pbits	CFI or DEI	VID	Port #
D	MAC4	MAC3	n/a	n/a	n/a	n/a	0x88A8	SPbit2	x	SVID2	x	x	x	GEM1	n/a	n/a	n/a	n/a	0x8100	CPbit2	n/a	CVID2	1

Test Procedure

1. Select distinct random values for CVID1, CVID2 and SVID1, SVID2 between 1 and 4094.
2. Select distinct random values for CPbit1, CPbit2 and SPbit1, SPbit2 between 0 and 7.
3. Select distinct random values for unicast MAC addresses MAC1 to MAC4
4. Cause the OLT Emulator to send the configured OMCI message sequence to provision the ONU (Configuration1).
5. Inject and stop tagged traffic at the U-interface with the specified P-bit values and random VID values (Configuration 1 & 2).
6. Inject and stop tagged traffic at the S/R-interface with the specified P-bit values and random VID values (Configuration 1 & 2).
7. Cause the OLT Emulator to modify the service configuration on the ONU (MIB reset is not allowed), the same service configuration is used only VID, P-bit and filter are modified (Configuration 2)
8. Inject and stop tagged traffic at the U-interface with the specified P-bit values and random VID values (Configuration 1 & 2).
9. Inject and stop tagged traffic at the S/R-interface with the specified P-bit values and random VID values (Configuration 1 & 2).

OMCI Procedure Details

Refer to clause 4.3.

Pass/Fail Criteria

The test passes if the following are true, otherwise the test fails:

1. All upstream frames from stream A are received as S-tagged frames with TPID equal to 0x88A8, VID equal to SVID1 and P-bit set to SPBit1, and no frames from stream C are received at step 5
2. All downstream frames from stream B are received as C-tagged frames with TPID equal to 0x8100, VID equal to CVID1 and P-bit equal to CPBit1 and no frame from stream D are received at step 6
3. All upstream frames from stream C are received as S-tagged frames with TPID equal to 0x88A8, VID equal to SVID2 and P-bit set to SPBit2, and no frames from stream A are received at step 8

4. All downstream frames from stream D are received as C-tagged frames with TPID equal to 0x8100, VID equal to CVID2 and P-bit equal to CPBit2 and no frame from stream B are received at step 9

Remarks

- None.

6.12.3 Unicast GEM port encryption in the downstream direction

Test Name

Unicast GEM port encryption in the downstream direction

Test Definition Number

ONU.6.12.3

Reference Document

BBF TR-280 [23]

ITU-T G.988 [6][7][8]

Test Type

Conformance

Test Requirement Type

Mandatory

Unit Under Test

ONU

Requirement Description**BBF TR-280**

- **R-66** The ONU MUST support GEM port encryption for all unicast GEM ports

Test Objective

Verify that the ONU is able to support encryption in downstream direction.

Test Configuration

1. OLT Emulator and ONU under test are powered and connected to ODN
2. ONU under test has been activated by the OLT Emulator, has been ranged, and a GEM port for OMCI has been created as a result of ONU-ID assignment.
3. The OLT Emulator configure through OMCI the ONU under test:
 - To support 1 traffic class (i.e., P-bit mapping)

- With 1 GEM port and 1 downstream queue for each traffic class
4. The Ethernet Traffic Generator and the OLT Emulator will be configured to transmit one flow of double-tagged Ethernet frames with the parameters in the next table. Also, GEM port mapping is shown

Downstream Direction																							
Traffic Stream	S/R Interface														U Interface								
	MAC DA	MAC SA	Outer VLAN Tag				Inner VLAN Tag				Ethertype	IP DA	IP SA	GEM	Outer VLAN Tag				Inner VLAN Tag				UNI
	Value	Value	TPID	Pbits	DEI	VID	TPID	Pbits	CFI or DEI	VID	Value	Value	Value	Port #	TPID	Pbits	DEI	VID	TPID	Pbits	CFI or DEI	VID	Port #
A	MAC2	MAC1	n/a	n/a	n/a	n/a	0x88A8	SPbit1	x	SVID1	x	x	x	GEM1	n/a	n/a	n/a	n/a	0x8100	CPbit1	n/a	CVID1	1

The OLT Emulator will be configured to send the sequence of PLOAM and OMCI messages required to fulfill the AES key exchange.

Test Procedure

1. Select distinct random values for MAC address: MAC1, MAC2
2. Select distinct random values for CVID1 and SVID1 between 1 and 4094.
3. Select distinct random values for CPbit1 and SPbit1
4. Cause the OLT Emulator to send the configured OMCI message sequence to provision the ONU
5. Launch traffic in downstream direction
6. Cause the OLT Emulator to request generation, exchange and activation of a new AES key by the ONU
7. Once the new key activation has succeeded, cause the OLT Emulator to activate encryption on the GEM port.

Note:

- a. For XG(S)-PON encryption, activation consists in setting the key index field in the XGEM header to a non-zero valid value.
- b. For G-PON encryption, activation consists in sending the PLOAM message Encrypted Port-ID with encrypted set to 1.

8. Cause the OLT Emulator to deactivate the encryption on the GEM port.

Note:

- a. For XG(S)-PON encryption, deactivation consists in setting the key index field in the XGEM header to zero.
- b. For G-PON encryption, deactivation consists in sending the PLOAM message Encrypted_Port-ID with encrypted set to 0.

OMCI Procedure Details

Refer to clause 4.3.

Pass/Fail Criteria

The test passes if the following are true, otherwise the test fails:

1. All PLOAM and OMCI commands are successful
2. The ONU is able to forward traffic in downstream direction without any packets lost at step 5
3. No packet loss is observed during PLOAM exchange at step 6
4. No packet loss is observed during AES activation of the GEM port at step 7 for XG(S)-PON and no or few packets loss is observed for G-PON
5. No packet loss is observed when AES is ON at step 7
6. No packet loss is observed during AES de-activation of the GEM port at step 8 for XG(S)-PON and no or few packets loss is observed for G-PON
7. No packet loss is observed when AES is OFF at step 8

Remarks

- None.

6.12.4 GEM port Encryption in the Upstream Direction

Test Name

GEM port Encryption in the Upstream Direction

Test Definition Number

ONU.6.12.4

Reference Document

BBF TR-280 [23]

ITU-T G.988 [6][7][8]

Test Type

Conformance

Test Requirement Type

Conditionally Mandatory (applies to all ONUs except G-PON ONUs)

Unit Under Test

ONU

Requirement Description

BBF TR-280

- **R-66** The ONU MUST support GEM port encryption for all unicast GEM ports

Test Objective

Verify that the ONU is able to support encryption in upstream direction.

Test Configuration

1. OLT Emulator and ONU under test are powered and connected to ODN
2. ONU under test has been activated by the OLT Emulator, has been ranged, and a GEM port for OMCI has been created as a result of ONU-ID assignment.
3. The OLT Emulator configure through OMCI the ONU under test:
 - To support 1 traffic class (i.e., P-bit mapping)

- With 1 GEM port and 1 downstream queue for each traffic class
4. The Ethernet Traffic Generator and the OLT Emulator will be configured to transmit one flow of untagged Ethernet frames with the parameters in the next table. Also, GEM port mapping is shown

		Upstream Direction																						
Traffic Stream	U Interface												R/S Interface											
	UNI	MAC DA	MAC SA	Outer VLAN Tag				Inner VLAN Tag				Ethertype	IP DA	IP SA	Outer VLAN Tag				Inner VLAN Tag				GEM	T-CONT
	Port #	Value	Value	TPID	Pbits	DEI	VID	TPID	Pbits	CFI or DEI	VID	Value	Value	Value	TPID	Pbits	DEI	VID	TPID	Pbits	CFI or DEI	VID	Port #	Number
A	1	MAC1	MAC2	n/a	n/a	n/a	n/a	n/a	n/a	n/a	n/a	x	x	x	n/a	n/a	n/a	n/a	0x88A8	SPbit1	x	SVID1	GEM1	TCONT1

5. The OLT Emulator will be configured to send the sequence of PLOAM and OMCI messages required to fulfill the AES key exchange.

Test Procedure

1. Select distinct random values for MAC address: MAC 1, MAC2
2. Select distinct random values for SVID1 between 1 and 4094.
3. Select distinct random values for SPbit1
4. Cause the OLT Emulator to send the configured OMCI message sequence to provision the ONU
5. Launch traffic in upstream direction
6. Cause the OLT Emulator to request generation, exchange and activation of a new AES key by the ONU
7. Once the new key activation has succeeded, cause the OLT Emulator to set the Encryption Status of the GEM port 1 to Encrypted
8. Cause the OLT Emulator to set the Encryption Status of the GEM port 1 to non-encrypted

OMCI Procedure Details

Refer to clause 4.3.

Pass/Fail Criteria

The test passes if the following are true, otherwise the test fails:

1. All PLOAM and OMCI commands are successful
2. The ONU is able to forward traffic in upstream direction without any packets lost at step 5
3. No packet loss is observed during PLOAM exchange at step 6
4. No packet loss is observed during AES activation of the GEM port at step 7
5. No packet loss is observed when AES is ON at step 7

6. No packet loss is observed during AES de-activation of the GEM port at step 8
7. No packet loss is observed when AES is OFF at step 8

Remarks

- None.

6.12.5 ONU Remote Debug

Test Name

ONU Remote Debug

Test Definition Number

ONU.6.12.5

Reference Document

BBF TR-280 [23]

ITU-T G.988 [6][7][8]

Test Type

Conformance

Test Requirement Type

Mandatory

Unit Under Test

ONU

Requirement Description

TR-280

- **R-57** The ONU MUST support remote debug ME ITU-T G.988
- **R-59** The OLT MUST support the ability to create the Remote debug ME and to send command to the ONU via OMCI as described in appendix I section I.2.8 [8]

Test Objective

Verify that the ONU is able to exchange information with the OLT for the purpose of debugging an ONU from an OLT.

Test Configuration

The vendor shall provide credential, if any, prior to the execution of the test in order to establish remote debug access.

The vendor may provide a vendor specific command to be used for remote debug and that is known by the ONU. If such a vendor specific command is provided, the vendor must describe the expected answer and its pattern to be provided by the ONU. Otherwise, by default, 'help' command will be used for this test. If the vendor uses a vendor specific pattern (in binary or ASCII format) in its responses to the remote debug commands, the vendor must provide the pattern (either binary or ASCII) that is expected from the ONU before the test execution.

1. OLT Emulator and ONU are powered on and connected to ODN
2. The ONU under test has been activated by the OLT Emulator, has been ranged, and a GEM port for OMCI has been created as a result of ONU-ID assignment
3. A single U-interface is used

Test Procedure

1. The OLT Emulator checks if the “ONU Remote DEBUG” Managed Entity is present at the ONU by reading the “Command Format” attribute.
2. Should credentials be requested by the ONU to establish remote debug access, they shall be sent by the OLT Emulator
3. Send the vendor specific command or “help” command using a set operation from the OLT Emulator to the ONU via the ONU remote debug managed entity
4. Read the ONU response using GET and GET NEXT operations on the reply table attribute from the OLT emulator to the ONU via the ONU remote debug managed entity.

OMCI Procedure Details

Refer to clause 4.3.

Pass/Fail Criteria

The test passes if the following are true, otherwise the test fails:

1. An answer is received by the OLT Emulator as a response from the ONU. This answer must be either:
 - a. A valid answer from the ONU as described by the vendor for the remote debug process or
 - b. An error response if the default ‘help’ command is not recognized

In case an error response is returned by the ONU to the unrecognized ASCII or binary command, no OMCI error shall occur due to this response as per G988 [1][7][8] §1.2.8 Remote debug.

Remarks

- None.

6.12.6 Create, Delete and Add New Services

Test Name

Create, Delete and Add New Services

Test Definition Number

ONU.6.12.6

Reference Document

BBF TR-280 [23]

BBF TR-280 Amendment 1 [24]

ITU-T G.988 [6][7][8]

Test Type

Conformance

Test Requirement Type

Mandatory

Unit Under Test

ONU

Requirement Description

ITU-T G.988 creates and delete of the ME associated to new service creation and delete

TR-156

- **R-63** The OLT and ONU MUST support scheduling of downstream queues according to strict priority among at least 4 TCs.

BBF TR-280 Amendment 1

- **R-90** The ONU MUST support traffic class deletion (traffic class as described in TR-156 Section 5) without causing any reboot, or MIB reset.
- **R-91** The ONU MUST support the deletion of a traffic class (traffic class as described in TR-156 Section 5) without causing any packet loss on existing traffic flows from other traffic classes.
- **R-92** The ONU MUST support traffic class addition (traffic class as described in TR-156 Section 5) without causing any reboot, or MIB reset.
- **R-93** The ONU MUST support the addition of a traffic class (traffic class as described in TR-156 Section 5) without causing any packet loss on existing traffic flows from other traffic classes when the addition does not cause any congestion in the ONU.

Test Objective

Verify that the ONU is able to create, delete and add new service, and also verify that strict priority is well applied

Test Configuration

1. OLT Emulator and ONU under test are powered and connected to ODN
2. ONU under test has been activated by the OLT Emulator, has been ranged, and a GEM port for OMCI has been created as a result of ONU-ID assignment.
3. The Traffic Generator and the OLT Emulator will be configured to transmit six flow of double-tagged Ethernet frames with the parameters in the next table. Also, GEM port mapping is shown

Configuration 1

Upstream Direction																								
Traffic Stream	U Interface														R/S Interface									
	UNI	MAC DA	MAC SA	Outer VLAN Tag				Inner VLAN Tag			Ethertype	IP DA	IP SA	Outer VLAN Tag				Inner VLAN Tag				GEM	T-CONT	
	Port #	Value	Value	TPID	Pbits	DEI	VID	TPID	Pbits	CFI or DEI	VID	Value	Value	Value	TPID	Pbits	DEI	VID	TPID	Pbits	CFI or DEI	VID	Port #	Number
A	1	MAC1	MAC2	n/a	n/a	n/a	n/a	0x8100	CPbit1	n/a	CVID1	x	x	x	n/a	n/a	n/a	n/a	0x88A8	SPbit1	x	SVID1	GEM1	TCONT1
B	1	MAC3	MAC4	n/a	n/a	n/a	n/a	0x8100	CPbit2	n/a	CVID1	x	x	x	n/a	n/a	n/a	n/a	0x88A8	SPbit2	x	SVID1	GEM2	TCONT2

Downstream Direction																								
Traffic Stream	S/R Interface														U Interface									
	MAC DA	MAC SA	Outer VLAN Tag				Inner VLAN Tag			Ethertype	IP DA	IP SA	GEM	DS PQ	Outer VLAN Tag				Inner VLAN Tag				UNI	
	Value	Value	TPID	Pbits	DEI	VID	TPID	Pbits	CFI or DEI	VID	Value	Value	Value	Port #	Number	TPID	Pbits	DEI	VID	TPID	Pbits	CFI or DEI	VID	Port #
C	MAC2	MAC1	n/a	n/a	n/a	n/a	0x88A8	SPbit1	x	SVID1	x	x	x	GEM1	PQ1	n/a	n/a	n/a	n/a	0x8100	CPbit1	n/a	CVID1	1
D	MAC4	MAC3	n/a	n/a	n/a	n/a	0x88A8	SPbit2	x	SVID1	x	x	x	GEM2	PQ0	n/a	n/a	n/a	n/a	0x8100	CPbit2	n/a	CVID1	1

Configuration 2

Upstream Direction																								
Traffic Stream	U Interface														R/S Interface									
	UNI	MAC DA	MAC SA	Outer VLAN Tag				Inner VLAN Tag			Ethertype	IP DA	IP SA	Outer VLAN Tag				Inner VLAN Tag				GEM	T-CONT	
	Port #	Value	Value	TPID	Pbits	DEI	VID	TPID	Pbits	CFI or DEI	VID	Value	Value	Value	TPID	Pbits	DEI	VID	TPID	Pbits	CFI or DEI	VID	Port #	Number
A	1	MAC1	MAC2	n/a	n/a	n/a	n/a	0x8100	CPbit1	n/a	CVID1	x	x	x	n/a	n/a	n/a	n/a	0x88A8	SPbit1	x	SVID1	GEM1	TCONT1
E	1	MAC5	MAC6	n/a	n/a	n/a	n/a	0x8100	CPbit3	n/a	CVID2	x	x	x	n/a	n/a	n/a	n/a	0x88A8	SPbit3	x	SVID2	GEM2	TCONT2

Downstream Direction																								
Traffic Stream	S/R Interface														U Interface									
	MAC DA		MAC SA		Outer VLAN Tag			Inner VLAN Tag			Ethertype	IP DA	IP SA	GEM	DS PQ	Outer VLAN Tag				Inner VLAN Tag			UNI	
	Value	Value	TPID	Pbits	DEI	VID	TPID	Pbits	CFI or DEI	VID	Value	Value	Value	Port #	Number	TPID	Pbits	DEI	VID	TPID	Pbits	CFI or DEI	VID	Port #
C	MAC2	MAC1	n/a	n/a	n/a	n/a	0x88A8	SPbit1	x	SVID1	x	x	x	GEM1	PQ1	n/a	n/a	n/a	n/a	0x8100	CPbit1	n/a	CVID1	1
F	MAC6	MAC5	n/a	n/a	n/a	n/a	0x88A8	SPbit3	x	SVID2	x	x	x	GEM2	PQ2	n/a	n/a	n/a	n/a	0x8100	CPbit3	n/a	CVID2	1

Note: Flows A & C are used in configurations 1 & 2.

Test Procedure

1. Select distinct random values for CVID1, CVID2 and SVID1, SVID2 between 1 and 4094.
2. Select distinct random values for CPbit1, CPbit2, CPbit3 and SPbit1, SPbit2, SPbit3 between 0 and 7.
3. Select distinct random values for unicast MAC addresses MAC1 to MAC6
4. Select three downstream Priority Queues for traffic at the ONU, PQ0, PQ1 and PQ2, in strictly decreasing order of priority.
Note that the mapping between GEM port and priorities is provided in the traffic table in Configuration Step 3.
5. Cause the OLT Emulator to send the configured OMCI message sequence to provision the ONU (Configuration1).
6. Inject and stop tagged traffic at the U-interface with the specified P-bit values and random VID values (Configuration 1 & 2).
7. Inject and stop tagged traffic at the S/R-interface with the specified P-bit values and random VID values (Configuration 1 & 2).
8. Cause the OLT Emulator to send the configured OMCI message sequence to delete the service associated to Stream B and D (to delete all necessary ME, pointers or entries, ex: GEM port CTP, GEM port IWTP, Extended VLAN...). MIB reset is not allowed
9. Inject and stop tagged traffic at the U-interface with the specified P-bit values and random VID values (Configuration 1 & 2).
10. Inject and stop tagged traffic at the S/R-interface with the specified P-bit values and random VID values (Configuration 1 & 2).
11. Cause the OLT Emulator to send the configured OMCI message sequence to create the service associated to stream E and F (to create all necessary ME, pointers or entries, ex: GEM port CTP, GEM port IWTP, Extended VLAN...). MIB reset is not allowed.
12. Inject and stop tagged traffic at the U-interface with the specified P-bit values and random VID values (Configuration 1 & 2).
13. Inject and stop tagged traffic at the S/R-interface with the specified P-bit values and random VID values (Configuration 1 & 2).

OMCI Procedure Details

Refer to clause 4.3.

Pass/Fail Criteria

The test passes if the following are true, otherwise the test fails:

1. All upstream frames from stream A and B are received as defined in the upstream table of configuration 1 at step 6
2. No frames from stream E are received at step 6
3. All downstream frames from stream C to D are received as defined in the downstream table of configuration 1 at step 7
4. No frame from stream F is received at step 7
5. All upstream frames from stream A are received as defined in the upstream table of configuration 1 for stream A at step 9
6. No frames from stream B and E are received at step 9
7. All downstream frames from stream C are received as defined in the downstream table of configuration 1 for stream C at step 10
8. No frame from stream D and F are received at step 10
9. All upstream frames from stream A and E are received as defined in the upstream table of configuration 2 at step 12
10. No frames from stream B are received at step 12
11. All downstream frames from stream C and F are received as defined in the downstream table of configuration 2 at step 13
12. No frames from stream D is received at step 13

Remarks

- None.

6.12.7 Create, Delete and Add New Services in Strict Priority Downstream Scheduling Context

Test Name

Create, Delete and Add New Services in Strict Priority Downstream Scheduling Context

Test Definition Number

ONU.6.12.7

Reference Document

BBF TR-280 [23]

BBF TR-280 Amendment 1 [24]

ITU-T G.988 [6][7][8]

Test Type

Conformance

Test Requirement Type

Conditionally Mandatory. Mandatory if ONU shows a PON throughput capacity greater (strictly) than the achievable throughput from the U interface of the ONU.

Unit Under Test

ONU

Requirement Description

ITU-T G.988 creates and delete of the ME associated to new service creation and delete

TR-156

- **R-63** The OLT and ONU MUST support scheduling of downstream queues according to strict priority among at least 4 TCs.

BBF TR-280 Amendment 1

- **R-90** The ONU MUST support traffic class deletion (traffic class as described in TR-156 Section 5) without causing any reboot, or MIB reset.
- **R-91** The ONU MUST support the deletion of a traffic class (traffic class as described in TR-156 Section 5) without causing any packet loss on existing traffic flows from other traffic classes.
- **R-92** The ONU MUST support traffic class addition (traffic class as described in TR-156 Section 5) without causing any reboot, or MIB reset.

- **R-93** The ONU MUST support the addition of a traffic class (traffic class as described in TR-156 Section 5) without causing any packet loss on existing traffic flows from other traffic classes when the addition does not cause any congestion in the ONU.

Test Objective

Verify that the ONU is able to create, delete and add new service, and also verify that strict priority is well applied

Test Configuration

1. OLT Emulator and ONU under test are powered and connected to ODN
2. ONU under test has been activated by the OLT Emulator, has been ranged, and a GEM port for OMCI has been created as a result of ONU-ID assignment.
3. The Traffic Generator and the OLT Emulator will be configured to transmit six flow of double-tagged Ethernet frames with the parameters in the next table. Also, GEM port mapping is shown

Configuration 1

Upstream Direction																								
Traffic Stream	U Interface													R/S Interface										
	UNI	MAC DA	MAC SA	Outer VLAN Tag				Inner VLAN Tag				Ethertype	IP DA	IP SA	Outer VLAN Tag				Inner VLAN Tag				GEM	T-CONT
	Port #	Value	Value	TPID	Pbits	DEI	VID	TPID	Pbits	CFI or DEI	VID	Value	Value	Value	TPID	Pbits	DEI	VID	TPID	Pbits	CFI or DEI	VID	Port #	Number
A	1	MAC1	MAC2	n/a	n/a	n/a	n/a	0x8100	CPbit1	n/a	CVID1	x	x	x	n/a	n/a	n/a	n/a	0x88A8	SPbit1	x	SVID1	GEM1	TCONT1
B	1	MAC3	MAC4	n/a	n/a	n/a	n/a	0x8100	CPbit2	n/a	CVID1	x	x	x	n/a	n/a	n/a	n/a	0x88A8	SPbit2	x	SVID1	GEM2	TCONT2

Downstream Direction																								
Traffic Stream	S/R Interface														U Interface									
	MAC DA	MAC SA	Outer VLAN Tag				Inner VLAN Tag				Ethertype	IP DA	IP SA	GEM	DS PQ	Outer VLAN Tag				Inner VLAN Tag				UNI
	Value	Value	TPID	Pbits	DEI	VID	TPID	Pbits	CFI or DEI	VID	Value	Value	Value	Port #	Number	TPID	Pbits	DEI	VID	TPID	Pbits	CFI or DEI	VID	Port #
C	MAC2	MAC1	n/a	n/a	n/a	n/a	0x88A8	SPbit1	x	SVID1	x	x	x	GEM1	PQ1	n/a	n/a	n/a	n/a	0x8100	CPbit1	n/a	CVID1	1
D	MAC4	MAC3	n/a	n/a	n/a	n/a	0x88A8	SPbit2	x	SVID1	x	x	x	GEM2	PQ0	n/a	n/a	n/a	n/a	0x8100	CPbit2	n/a	CVID1	1

Configuration 2

Upstream Direction																								
Traffic Stream	U Interface												R/S Interface											
	UNI	MAC DA	MAC SA	Outer VLAN Tag				Inner VLAN Tag				Ethertype	IP DA	IP SA	Outer VLAN Tag				Inner VLAN Tag				GEM	T-CONT
	Port #	Value	Value	TPID	Pbits	DEI	VID	TPID	Pbits	CFI or DEI	VID	Value	Value	Value	TPID	Pbits	DEI	VID	TPID	Pbits	CFI or DEI	VID	Port #	Number
A	1	MAC1	MAC2	n/a	n/a	n/a	n/a	0x8100	CPbit1	n/a	CVID1	x	x	x	n/a	n/a	n/a	n/a	0x88A8	SPbit1	x	SVID1	GEM1	TCONT1
E	1	MAC5	MAC6	n/a	n/a	n/a	n/a	0x8100	CPbit3	n/a	CVID2	x	x	x	n/a	n/a	n/a	n/a	0x88A8	SPbit3	x	SVID2	GEM2	TCONT2

Downstream Direction																								
Traffic Stream	S/R Interface														U Interface									
	MAC DA	MAC SA	Outer VLAN Tag				Inner VLAN Tag				Ethertype	IP DA	IP SA	GEM	DS PQ	Outer VLAN Tag				Inner VLAN Tag				UNI
	Value	Value	TPID	Pbits	DEI	VID	TPID	Pbits	CFI or DEI	VID	Value	Value	Value	Port #	Number	TPID	Pbits	DEI	VID	TPID	Pbits	CFI or DEI	VID	Port #
C	MAC2	MAC1	n/a	n/a	n/a	n/a	0x88A8	SPbit1	x	SVID1	x	x	x	GEM1	PQ1	n/a	n/a	n/a	n/a	0x8100	CPbit1	n/a	CVID1	1
F	MAC6	MAC5	n/a	n/a	n/a	n/a	0x88A8	SPbit3	x	SVID2	x	x	x	GEM2	PQ2	n/a	n/a	n/a	n/a	0x8100	CPbit3	n/a	CVID2	1

Note: Flows A & C are used in configurations 1 & 2.

Test Procedure

1. Select distinct random values for CVID1, CVID2 and SVID1, SVID2 between 1 and 4094.
2. Select distinct random values for CPbit1, CPbit2, CPbit3 and SPbit1, SPbit2, SPbit3 between 0 and 7.
3. Select distinct random values for unicast MAC addresses MAC1 to MAC6
4. Select three downstream Priority Queues for traffic at the ONU, PQ0, PQ1 and PQ2, in strictly decreasing order of priority.
Note that the mapping between GEM port and priorities is provided in the traffic table in Configuration Step 3.
5. Cause the OLT Emulator to send the configured OMCI message sequence to provision the ONU (Configuration1).
6. Inject and stop tagged traffic at the U-interface with the specified P-bit values and random VID values (Configuration 1 & 2).
7. Inject and stop tagged traffic at the S/R-interface with the specified P-bit values and random VID values (Configuration 1 & 2).
8. Initially, streams C and D will be sent at the same bit rate and the total bit rate will be below the maximum bandwidth available at the U-interface
9. Gradually increase the bit rate of stream D until losses of frames for stream C appears on the Ethernet Traffic Generator
10. Cause the OLT Emulator to send the configured OMCI message sequence to delete the service associated to Stream B and D (to delete all necessary ME, pointers or entries, ex: GEM port CTP, GEM port IWTP, Extended VLAN...). MIB reset is not allowed
11. Inject and stop tagged traffic at the U-interface with the specified P-bit values and random VID values (Configuration 1 & 2).
12. Inject and stop tagged traffic at the S/R-interface with the specified P-bit values and random VID values (Configuration 1 & 2).

13. Cause the OLT Emulator to send the configured OMCI message sequence to create the service associated to stream E and F (to create all necessary ME, pointers or entries, ex: GEM port CTP, GEM port IWTP, Extended VLAN...). MIB reset is not allowed.
14. Inject and stop tagged traffic at the U-interface with the specified P-bit values and random VID values (Configuration 1 & 2).
15. Inject and stop tagged traffic at the S/R-interface with the specified P-bit values and random VID values (Configuration 1 & 2).
16. Initially, streams C and F will be sent at the same bit rate and the total bit rate will be below the maximum bandwidth available at the U-interface
17. Gradually increase the bit rate of stream C until losses of frames for stream F appears on the Ethernet Traffic Generator

OMCI Procedure Details

Refer to clause 4.3.

Pass/Fail Criteria

The test passes if the following are true, otherwise the test fails:

1. All upstream frames from stream A and B are received as defined in the upstream table of configuration 1 at step 6
2. No frames from stream E are received at step 6
3. All downstream frames from stream C to D are received as defined in the downstream table of configuration 1 at step 7
4. No frame from stream F is received at step 7
5. There is no loss of frames for both C and D flows at the U-interface at step 8
6. There is only loss of frames for the C at the U-interface at step 9
7. All upstream frames from stream A are received as defined in the upstream table of configuration 1 for stream A at step 11
8. No frames from stream B and E are received at step 11
9. All downstream frames from stream C are received as defined in the downstream table of configuration 1 for stream C at step 12
10. No frame from stream D and F are received at step 12
11. All upstream frames from stream A and E are received as defined in the upstream table of configuration 2 at step 14
12. No frames from stream B are received at step 14
13. All downstream frames from stream C and F are received as defined in the downstream table of configuration 2 at step 15
14. No frames from stream D is received at step 15
15. There is no loss of frames for both C and F flows at the U-interface at step 16
16. There is only loss of frames for the F at the U-interface at step 17

Remarks

- None.

6.13 Counters

6.13.1 Performance Monitoring on Ethernet Frames

Test Name

Performance Monitoring on Ethernet Frames

Test Definition Number

ONU.6.13.1

Reference Document

BBF TR-280 [23]

BBF TR-280 Amendment 1 [24]

ITU-T G.988 [6][7][8]

Test Type

Conformance

Test Requirement Type

Mandatory

Unit Under Test

ONU

Requirement Description**BBF TR-280**

- **R-25** The OLT and ONU MUST use OMCI in the configuration and reporting of Alarms and counters
- **R-27** Ethernet counters (32 bit) MUST report
 - received frames
 - sent frames
 - dropped received upstream frames due to MAC layer CRC errors
 - received multicast frames

- sent multicast frames
- **R-31** The OLT and the ONU MUST support Ethernet frame extended PM ME for the following:
 - Physical path termination point Ethernet UNI ME
 - GEM interworking termination point ME
 - Multicast GEM interworking termination point MEand based on any arbitrary combination of:
 - Upstream direction
 - Downstream direction
 - VID
 - P-bit
- **R-36** The OLT/ONU MUST be able to configure and report on the counters specified in [R-37] to [R-40]
- **R-37** The ONU MUST have Ethernet counters per R/S interface for upstream traffic based on:
 - GEM port
 - VID
 - P-bit
 - VID+P-bit
- **R-38** The ONU MUST have Ethernet counters per U interface for upstream traffic based on:
 - Total traffic
 - VID
 - P-bit
 - VID+P-bit
- **R-39** The ONU MUST have Ethernet counters per R/S interface for downstream traffic based on:
 - GEM port
 - VID
 - Pbit
 - VID+P-bit

- **R-40** The ONU MUST have Ethernet counters per U interface for downstream traffic based on:
 - Total traffic
 - VID
 - P-bit
 - VID+P-bit

BBF TR-280 Amendment 1

- **R-84** The ONU MUST support that counters belonging to Ethernet Frame Extended PM ME instances with a matching criterion be incremented for one of the following scenarios: (all frames and VID) or (all frames and VID+P-bit) or (all frames and P-bit).

Note: An OLT may create two or more Extended PM ME instances on a monitoring point: one Extended PM ME instance to count all received frames without regard to VID or P-bit, other Extended PM ME instances to filter the collected PM data based on the matching VID, or P-bit, or VID + P-bit. If a received Ethernet frame matches the specific filtering criteria defined in one of the other Extended PM ME instances, the ONU needs to increment the corresponding counters in the Extended PM ME instance with the matching filtering criteria, and in the Extended PM ME instance that counts all received frames.

- **R-85** The OLT MUST support the instantiation of at least 16 Ethernet Frame Extended PM Managed Entity instances when the ONU is provisioned.

Note: The use case that explains the 16 Extended PM ME instances is the following. Consider an ONU that has 4 bidirectional traffic flows and 4 GEM ports, each traffic flow corresponds to a traffic class (as per [R-46] in TR-156 [20]), and one GEM port per traffic class (as per [R-7] in TR-156 [20]). Such ONU is required to support:

- 8 Extended PM ME instances on the U-interface (i.e., 1 ME instance per traffic class per upstream/downstream direction).
- 8 Extended PM ME instances on the R/S interface (i.e., 1 ME instance per GEM port per upstream/downstream direction).
- **R-86** The ONU MUST support the instantiation of at least 16 Ethernet Frame Extended PM Managed Entity instances.

Note: Refer to the note in [R-85] for the example use case.

Test Objective

- Verify that the ONU is able to monitor Ethernet traffic on the U interface and GEM ports for both directions.
- Verify that counters can be assigned per VLAN ID and/or P-bit.
- Verify that counters per frame and per multicast frame are provided.
- Verify that the ONU supports the instantiation of 16 Ethernet Frame Extended PM MEs.

Test Configuration

1. OLT Emulator and ONU under test are powered and connected to the ODN.
2. The ONU under test has been activated by the OLT emulator, has been ranged, and a GEM port for OMCI has been created as a result of ONU-ID assignment.
3. The OLT emulator configures the ONU under test through OMCI:
 - To support 3 traffic classes (i.e., P-bit mapping)
 - With 1 GEM port and 1 downstream queue for each traffic class
4. The Ethernet Traffic Generator and OLT emulator will be configured to transmit 4 flows of double-tagged Ethernet frames, in both directions, with the parameters in the next tables. GEM port mappings are also provided.

Upstream Direction																								
Traf # Stream	U Interface													R/S Interface										
	UNI	MAC DA	MAC SA	Outer VLAN Tag				Inner VLAN Tag				Ethertype	IP DA	IP SA	Outer VLAN Tag				Inner VLAN Tag				GEM	T-CONT
	Port #	Value	Value	TPID	Pbits	DEI	VID	TPID	Pbits	CFI or DEI	VID	Value	Value	Value	TPID	Pbits	DEI	VID	TPID	Pbits	CFI or DEI	VID	Port #	Number
A	1	MAC1	MAC2	n/a	n/a	n/a	n/a	0x88A8	SPbit1	n/a	SVID1	x	x	x	n/a	n/a	n/a	n/a	0x88A8	SPbit1	x	SVID1	GEM1	TCONT1
B	1	MAC1	MAC2	n/a	n/a	n/a	n/a	0x88A8	SPbit2	n/a	SVID1	x	x	x	n/a	n/a	n/a	n/a	0x88A8	SPbit2	x	SVID1	GEM1	TCONT1
C	1	MAC1	MAC2	n/a	n/a	n/a	n/a	0x88A8	SPbit1	n/a	SVID2	x	x	x	n/a	n/a	n/a	n/a	0x88A8	SPbit1	x	SVID2	GEM2	TCONT2
D	1	MAC1	MAC2	n/a	n/a	n/a	n/a	0x88A8	SPbit3	n/a	SVID3	x	x	x	n/a	n/a	n/a	n/a	0x88A8	SPbit3	x	SVID3	GEM3	TCONT3

Downstream Direction																								
Traf # Stream	S/R Interface													U Interface										
	MAC DA	MAC SA	Outer VLAN Tag				Inner VLAN Tag				Ethertype	IP DA	IP SA	GEM	Outer VLAN Tag				Inner VLAN Tag				UNI	
	Value	Value	TPID	Pbits	DEI	VID	TPID	Pbits	CFI or DEI	VID	Value	Value	Value	Port #	TPID	Pbits	DEI	VID	TPID	Pbits	CFI or DEI	VID	Port #	Number
E	MAC2	MAC1	n/a	n/a	n/a	n/a	0x88A8	SPbit1	x	SVID1	x	x	x	GEM1	n/a	n/a	n/a	n/a	0x88A8	SPbit1	n/a	SVID1	1	
F	MAC2	MAC1	n/a	n/a	n/a	n/a	0x88A8	SPbit2	x	SVID1	x	x	x	GEM1	n/a	n/a	n/a	n/a	0x88A8	SPbit2	n/a	SVID1	1	
G	MAC2	MAC1	n/a	n/a	n/a	n/a	0x88A8	SPbit2	x	SVID2	x	x	x	GEM2	n/a	n/a	n/a	n/a	0x88A8	SPbit2	n/a	SVID2	1	
H	MAC2	MAC1	n/a	n/a	n/a	n/a	0x88A8	SPbit3	x	SVID4	x	x	x	GEM3	n/a	n/a	n/a	n/a	0x88A8	SPbit3	n/a	SVID4	1	

Test Procedure

1. Select distinct random values for MAC addresses: MAC 1, MAC2
2. Select distinct random values for SVID1, SVID2, SVID3, SVID4 and SVID5 between 1 and 4094.
3. Select distinct random values for SPbit1, SPbit2, SPbit3 and SPbit4.
4. Cause the OLT emulator to send the configured OMCI message sequence to provision the ONU.
5. Cause the OLT emulator to create Ethernet Frame Extended PM MEs for:
 - PPTP ME for upstream traffic
 - PPTP ME for upstream traffic SVID1+SPbit1

- PPTP ME for upstream traffic SVID1+SPbit2
 - PPTP ME for upstream traffic SVID2
 - PPTP ME for upstream traffic SPbit3
 - PPTP ME for downstream traffic
 - PPTP ME for downstream traffic SVID1+SPbit1
 - PPTP ME for downstream traffic SVID1+SPbit2
 - PPTP ME for downstream traffic SVID2
 - PPTP ME for downstream traffic SPbit3
 - GEM interworking termination point ME for upstream traffic (one for each GEM port)
 - GEM interworking termination point ME for downstream traffic (one for each GEM port)
6. Cause the OLT emulator to retrieve all ONU counters.
 7. Cause the OLT emulator to clear all ONU counters.
 8. Cause the OLT emulator to retrieve only the ONU counters listed in requirement TR-280 [22] R-27.
 9. Cause the Traffic Generator to send 10 000 packets for each flow, upstream and downstream, as defined in Test Configuration step 4.
 10. Cause the OLT emulator to retrieve all ONU counters.
 11. Cause the OLT emulator clear all ONU counters.
 12. Cause the OLT emulator to retrieve only the ONU counters listed in requirement TR-280 [22] R-27.
 13. Cause the Ethernet Traffic Generator to send 10 000 packets downstream as defined below (GEM port mappings implemented by the OLT emulator are also provided).

		Downstream Direction																					
Traffic Stream	S/R Interface															U Interface							
	MAC DA	MAC SA	Outer VLAN Tag				Inner VLAN Tag				Ethertype	IP DA	IP SA	GEM	Outer VLAN Tag				Inner VLAN Tag			UNI	
	Value	Value	TPID	Pbits	DEI	VID	TPID	Pbits	CFI or DEI	VID	Value	Value	Value	Port #	TPID	Pbits	DEI	VID	TPID	Pbits	CFI or DEI	VID	Port #
I	MAC2	MAC1	n/a	n/a	n/a	n/a	0x88A8	SPbit3	x	SVID1	x	x	x	GEM1	n/a	n/a	n/a	n/a	n/a	n/a	n/a	n/a	n/a

14. Cause the OLT emulator to retrieve all U interface counters for downstream flow I
15. Cause the OLT emulator to retrieve all GEM interworking termination point counters for downstream flows.

16. Cause the Ethernet Traffic Generator to send 10 000 packets downstream as defined below (GEM port mappings implemented by the OLT emulator are also provided).

Downstream Direction																							
Traffic Stream	S/R Interface														U Interface								
	MAC DA	MAC SA	Outer VLAN Tag				Inner VLAN Tag				Ethertype	IP DA	IP SA	GEM	Outer VLAN Tag				Inner VLAN Tag				UNI
	Value	Value	TPID	Pbits	DEI	VID	TPID	Pbits	CFI or DEI	VID	Value	Value	Value	Port #	TPID	Pbits	DEI	VID	TPID	Pbits	CFI or DEI	VID	Port #
	J	MAC2	MAC1	n/a	n/a	n/a	n/a	0x88A8	SPbit1	x	SVID2	x	x	x	GEM1	n/a	n/a	n/a	n/a	n/a	n/a	n/a	n/a
K	MAC2	MAC1	n/a	n/a	n/a	n/a	0x88A8	SPbit2	x	SVID1	x	x	x	GEM2	n/a	n/a	n/a	n/a	n/a	n/a	n/a	n/a	n/a
L	MAC2	MAC1	n/a	n/a	n/a	n/a	0x88A8	SPbit1	x	SVID5	x	x	x	GEM3	n/a	n/a	n/a	n/a	n/a	n/a	n/a	n/a	n/a

- 17. Cause the OLT emulator to retrieve all U interface counters for downstream flows.
- 18. Cause the OLT emulator to retrieve all GEM interworking termination point counters for downstream flows.
- 19. Cause the OLT emulator to clear all ONU counters.
- 20. Cause the OLT emulator to retrieve only the ONU counters listed in requirement TR-280 [22] R-27.
- 21. Cause the Ethernet Traffic Generator to send 10 000 packets upstream as defined below:

Upstream Direction																								
Traffic Stream	U Interface														R/S Interface									
	UNI	MAC DA	MAC SA	Outer VLAN Tag				Inner VLAN Tag				Ethertype	IP DA	IP SA	Outer VLAN Tag				Inner VLAN Tag				GEM	T-CONT
	Port #	Value	Value	TPID	Pbits	DEI	VID	TPID	Pbits	CFI or DEI	VID	Value	Value	Value	TPID	Pbits	DEI	VID	TPID	Pbits	CFI or DEI	VID	Port #	Number
	M	1	MAC1	MAC2	n/a	n/a	n/a	n/a	0x88A8	SPbit4	n/a	SVID1	x	x	x	n/a	n/a	n/a	n/a	n/a	n/a	n/a	n/a	n/a
N	1	MAC1	MAC2	n/a	n/a	n/a	n/a	0x88A8	SPbit1	n/a	SVID3	x	x	x	n/a	n/a	n/a	n/a	n/a	n/a	n/a	n/a	n/a	n/a

- 22. Cause the OLT emulator to retrieve all GEM interworking termination point counters for upstream flows.
- 23. Cause the OLT emulator to retrieve all U interface counters for upstream flows.

OMCI Procedure Details

Refer to Annex B

Pass/Fail Criteria

The test passes if the following are true, otherwise the test fails:

1. All OMCI commands have Success responses.
2. The ONU is able to send all counters to the OLT emulator at step 6.
3. All retrieved counters are zeroed at step 8.
4. The ONU is able to forward in both direction all flows and packets at step 9.

5. All Frame counters are incremented correctly based on their matching criteria at step 10.
6. No Multicast Frame counter is incremented at step 10.
7. All retrieved counters are zeroed at step 12.
8. At step 14, if the ONU forwards flow I, the Frame Counter for all downstream traffic in the downstream direction for the U Interface is incremented. The other counters of the U interface are not checked.
9. At step 14, if the ONU does not forward flow I, all U interface frame counters are 0
10. Only Frame counters related to the following ME are incremented at step 15: GEM interworking termination point ME for downstream traffic for GEM 1
11. No packet is forwarded in the downstream direction at step 16.
12. All U interface counters are zero at step 17
13. Only Frame counters related to the following ME are incremented at step 18
 - GEM interworking termination point ME for downstream traffic (1 for each GEM port)
14. All retrieved counters are zeroed at step 20.
15. No packet is forwarded in upstream direction at step 21.
16. All GEM interworking termination point ME counters are zero at step 22.
17. Only Frame counters related to the following ME are incremented at step 23.
 - PPTP Ethernet UNI ME for upstream traffic

Remarks

The expressions of type « all ONU counters » and «all GEM interworking termination point counters » and « all U interface counters » refers to the Frames and Multicast Frame counters in the specified direction and for the specified entity.

6.13.2 Performance Monitoring on Multicast Ethernet Frames

Test Name

Performance Monitoring on Multicast Ethernet Frames

Test Definition Number

ONU.6.13.2

Reference Document

BBF TR-280 [23]

BBF TR-280 Amendment 1 [24]

ITU-T G.988 [6][7][8]

Test Type

Conformance

Test Requirement Type

Conditionally Mandatory. This test is mandatory if ONU has applied to Profile F – Enhanced Multicast Operations.

Unit Under Test

ONU

Requirement Description**BBF TR-280**

- **R-25** The OLT and ONU MUST use OMCI in the configuration and reporting of Alarms and counters
- **R-27** Ethernet counters (32 bit) MUST report
 - received frames
 - sent frames
 - dropped received upstream frames due to MAC layer CRC errors
 - received multicast frames
 - sent multicast frames
- **R-31** The OLT and the ONU MUST support Ethernet frame extended PM ME for the following:

- Physical path termination point Ethernet UNI ME
- GEM interworking termination point ME
-

and based on any arbitrary combination of:

- Upstream direction
 - Downstream direction
 - VID
 - P-bit
- **R-36** The OLT/ONU MUST be able to configure and report on the counters specified in [R-37] to [R-40]
 - **R-37** The ONU MUST have Ethernet counters per R/S interface for upstream traffic based on:
 - GEM port
 - VID
 - P-bit
 - VID+P-bit
 - **R-38** The ONU MUST have Ethernet counters per U interface for upstream traffic based on:
 - Total traffic
 - VID
 - P-bit
 - VID+P-bit
 - **R-39** The ONU MUST have Ethernet counters per R/S interface for downstream traffic based on:
 - GEM port
 - VID
 - P-bit
 - VID+P-bit
 - **R-40** The ONU MUST have Ethernet counters per U interface for downstream traffic based on:
 - Total traffic

- VID
- P-bit
- VID+P-bit

BBF TR-280 Amendment 1

- **R-84** The ONU MUST support that counters belonging to Ethernet Frame Extended PM ME instances with a matching criterion be incremented for one of the following scenarios: (all frames and VID) or (all frames and VID+P-bit) or (all frames and P-bit).

Note: An OLT may create two or more Extended PM ME instances on a monitoring point: one Extended PM ME instance to count all received frames without regard to VID or P-bit, other Extended PM ME instances to filter the collected PM data based on the matching VID, or P-bit, or VID + P-bit. If a received Ethernet frame matches the specific filtering criteria defined in one of the other Extended PM ME instances, the ONU needs to increment the corresponding counters in the Extended PM ME instance with the matching filtering criteria, and in the Extended PM ME instance that counts all received frames.

- **R-85** The OLT MUST support the instantiation of at least 16 Ethernet Frame Extended PM Managed Entity instances when the ONU is provisioned.

Note: The use case that explains the 16 Extended PM ME instances is the following. Consider an ONU that has 4 bidirectional traffic flows and 4 GEM ports, each traffic flow corresponds to a traffic class (as per [R-46] in TR-156 [20]), and one GEM port per traffic class (as per [R-7] in TR-156 [20]). Such ONU is required to support:

- 8 Extended PM ME instances on the U-interface (i.e., 1 ME instance per traffic class per upstream/downstream direction).
- 8 Extended PM ME instances on the R/S interface (i.e., 1 ME instance per GEM port per upstream/downstream direction).

- **R-86** The ONU MUST support the instantiation of at least 16 Ethernet Frame Extended PM Managed Entity instances.

Note: Refer to the note in [R-85] for the example use case.

Test Objective

Verify that the ONU is able to monitor multicast & generic traffic on Ethernet frames on the U interface and on the Multicast GEM port.

Test Configuration

1. OLT Emulator and ONU under test are powered and connected to the ODN.
2. The ONU under test has been activated by the OLT emulator, has been ranged, and a GEM port for OMCI has been created as a result of ONU-ID assignment.
3. The OLT emulator configures the ONU under test through OMCI:
 - A bidirectional GEM port between the ONU under test U-interface and the OLT emulator has been created by OMCI, for IGMP messages.
 - A multicast GEM port between the ONU under test and the OLT emulator has been created by OMCI, for multicast Ethernet frames.

- The Ethernet Traffic Generator and OLT emulator will be configured to transmit 2 flows of double-tagged Ethernet frames in both directions with the parameters provided in the next tables. GEM port mappings are also provided.

Upstream Direction																								
Traffic Stream	U Interface														R/S Interface									
	UNI	MAC DA	MAC SA	Outer VLAN Tag				Inner VLAN Tag				Ethertype	IP DA	IP SA	Outer VLAN Tag				Inner VLAN Tag			GEM	T-CONT	
	Port #	Value	Value	TPID	Pbits	DEI	VID	TPID	Pbits	CFI or DEI	VID	Value	Value	Value	TPID	Pbits	DEI	VID	TPID	Pbits	CFI or DEI	VID	Port #	Number
A	1	MAC1	MAC2	n/a	n/a	n/a	n/a	0x88A8	SPbit1	n/a	SVID1	x	x	x	n/a	n/a	n/a	n/a	0x88A8	SPbit1	x	SVID1	GEM1	TCONT1
B	1	MAC1	MAC2	n/a	n/a	n/a	n/a	0x88A8	SPbit2	n/a	SVID2	x	x	x	n/a	n/a	n/a	n/a	0x88A8	SPbit2	x	SVID2	GEM1	TCONT1

Downstream Direction																							
Traffic Stream	S/R Interface														U Interface								
	MAC DA	MAC SA	Outer VLAN Tag				Inner VLAN Tag				Ethertype	IP DA	IP SA	GEM	Outer VLAN Tag				Inner VLAN Tag			UNI	
	Value	Value	TPID	Pbits	DEI	VID	TPID	Pbits	CFI or DEI	VID	Value	Value	Value	Port #	TPID	Pbits	DEI	VID	TPID	Pbits	CFI or DEI	VID	Port #
C	MAC2	MAC1	n/a	n/a	n/a	n/a	0x88A8	SPbit1	x	SVID1	x	x	x	GEM1	n/a	n/a	n/a	n/a	0x8100	SPbit1	n/a	SVID1	1
D	MAC2	MAC1	n/a	n/a	n/a	n/a	0x88A8	SPbit2	x	SVID2	x	x	x	GEM1	n/a	n/a	n/a	n/a	0x8100	SPbit2	n/a	SVID2	1

- The Ethernet Traffic Generator will be configured to transmit the downstream multicast Ethernet frames as defined below:

Channel	Multicast source IP address	Multicast IP group address	Multicast MAC group address	VID	P-bit
Ch1	IP-S1	IP-G1	MAC-G1	SVID1	SPbit1
Ch2	IP-S2	IP-G2	MAC-G2	SVID2	SPbit2

- The Ethernet Traffic Generator will be configured to transmit the following upstream IGMP v2 messages

Source IP address	Source MAC address	Multicast IP group address	VID	P-bit
IP-U1	MAC2	IP-G1	SVID1	SPbit1
IP-U1	MAC2	IP-G2	SVID2	SPbit2

Test Procedure

- Select distinct random values for MAC address: MAC 1, MAC2.
- Select distinct random values for multicast IP group addresses: IP-G1, IP-G2.
- Use associated multicast MAC addresses: MAC-G1, MAC-G2.
- Select distinct random values for IP addresses: IP-S1, IP-S2.

5. Select distinct random values for SVID1 and SVID2 between 1 and 4094.
6. Select distinct random values for SPbit1 and SPbit2.
7. Cause the OLT emulator to send the configured OMCI message sequence to provision the ONU.
8. Cause the OLT emulator to create Ethernet Frame Extended PM MEs for:
 - PPTP ME for upstream traffic
 - PPTP ME for upstream traffic SVID1 and SPbit1
 - PPTP ME for upstream traffic SVID2 and SPbit2
 - PPTP ME for downstream traffic
 - PPTP ME for downstream traffic SVID1 and SPbit1
 - PPTP ME for downstream traffic SVID2 and SPbit2
 - GEM interworking termination point ME for upstream traffic
 - GEM interworking termination point ME for downstream traffic
 - Multicast GEM interworking termination point ME for downstream traffic
9. Configure the OLT emulator to forward all multicast traffic to the multicast GEM Port permanently.
10. Via the OLT emulator, configure the dynamic access list control table of the Multicast Operations Profile ME at the ONU as shown in the following table:

Table Index	VLAN ID	Multicast source IP address	Multicast IP group address
IND1	SVID1	0.0.0.0	IP-G1
IND2	SVID2	0.0.0.0	IP-G2

11. Cause the OLT emulator to retrieve all ONU counters.
12. Cause the Ethernet Traffic Generator to send an IGMP Join on Channel Ch1.
13. Cause the OLT emulator to clear all ONU counters.
14. Cause the Ethernet Traffic Generator to send 10 000 packets for the downstream multicast flows defined in Configuration step 5.
15. Cause the OLT emulator to retrieve all ONU counters.

16. Cause the Ethernet Traffic Generator to an IGMP Join on Channel Ch2.
17. Cause the OLT emulator clears all ONU counters.
18. Cause the Ethernet Traffic Generator to send 10 000 packets for the downstream multicast flows defined in Configuration step 5.
19. Cause the OLT emulator to retrieve all ONU counters.
20. Cause the OLT emulator to clear all ONU counters.
21. Cause the Ethernet Traffic Generator to send 100 upstream IGMP messages as defined in Test Configuration step 6.
22. Cause the OLT emulator to retrieve all ONU counters.
23. Cause the OLT emulator to clear all ONU counters.
24. Cause the Ethernet Traffic Generator to send 10 000 packets for each flow, upstream and downstream, as defined in Test Configuration step 4.
25. Cause the OLT emulator to retrieve all ONU counters.
26. Cause the OLT emulator to clear all ONU counters.
27. Cause the OLT emulator to retrieve all ONU counters.
28. Configure the OLT emulator to forward all unicast downstream traffic to the multicast GEM Port.
29. Cause the Ethernet Traffic Generator to send 10 000 packets in downstream direction, as defined in Test Configuration step 4.
30. Cause the OLT emulator to retrieve all ONU counters.

OMCI Procedure Details

Refer to clause 4.3.

Pass/Fail Criteria

The test passes if the following are true, otherwise the test fails:

1. All OMCI commands have Success responses.
2. The ONU is able to send all counters to the OLT emulator at step 11.
3. The ONU is able to clear all counters at step 13.
4. The ONU is able to forward in the downstream direction all the multicast packets from Channel 1 at step 14.
5. Only the Frames and Multicast frames counters associated to the following MEs are incremented at step 15 (all other ONU Frame and Multicast Frames counters are zero):
 - Multicast GEM interworking termination point ME for downstream traffic, by 20 000.
 - PPTP ME for downstream traffic, by 10 000.

- PPTP ME for downstream traffic SVID1 and SPbit1, by 10 000.
6. The ONU is able to clear all counters at step 17.
 7. The ONU is able to forward in downstream direction all multicast packets at step 18.
 8. Only the Frames and Multicast frames counters associated to the following MEs are incremented at step 19 (all other ONU Frame and Multicast counters are zero):
 - Multicast GEM interworking termination point ME for downstream traffic, by 20 000.
 - PPTP ME for downstream traffic, by 20 000.
 - PPTP ME for downstream traffic SVID1 and SPbit1, by 10 000.
 - PPTP ME for downstream traffic SVID2 and SPbit2, by 10 000.
 9. The ONU is able to clear all counters at step 20.
 10. The ONU is able to forward in the upstream direction all the multicast packets at step 21.
 11. Only Frames and Multicast frames counters associated to the following MEs are incremented at step 22 (all other ONU Frame and Multicast Frames counters are zero):
 - PPTP ME for upstream traffic
 - PPTP ME for upstream traffic SVID1 and SPbit1
 - PPTP ME for upstream traffic SVID2 and SPbit2
 - GEM interworking termination point ME for upstream traffic
 12. The ONU is able to clear all counters at step 23.
 13. The ONU is able to forward in upstream and downstream direction all unicast packets at step 24.
 14. Only the Frames counters associated to the following MEs are incremented at step 25 (all other ONU Frames and Multicast Frames counters are zero):
 - PPTP ME for upstream traffic
 - PPTP ME for upstream traffic SVID1 and SPbit1
 - PPTP ME for upstream traffic SVID2 and SPbit2
 - PPTP ME for downstream traffic
 - PPTP ME for downstream traffic SVID1 and SPbit1

- PPTP ME for downstream traffic SVID2 and SPbit2
- GEM interworking termination point ME for upstream traffic
- GEM interworking termination point ME for downstream traffic

15. The ONU is able to clear all counters at step 26.

16. Only Frame counters associated to the following MEs are incremented at step 30 (all other ONU Frames and Multicast Frames counters are zero):

- Multicast GEM interworking termination point ME for downstream traffic

Remarks

The expressions of type « all ONU counters » and «all GEM interworking termination point counters » and « all U interface counters » refers to the Frames and Multicast Frame counters in the specified direction and for the specified entity.

Annex A: Test Case Template

Test Name

Descriptive name of test.

Test Definition Number

Test Definition Number = *ABC.x.y* where:

ABC Code identifying test type, as defined in the Test Plan:

- **ONU** for ONU Conformance Tests

x Subsection number from ID-247 within which this test is defined.

y Number of the test case.

Reference Document

BBF TR-156

ITU-T G.988,

Etc.

Test Type

Conformance

Test Requirement Type

Indicate if the test case is Mandatory or Optional. In general, test cases that verify mandatory (MUST) requirements would be defined as mandatory and test cases that verify optional (SHOULD/MAY) requirements will be defined as optional. However, the ultimate decision resides with the developers of this test plan. Tests that address a subset of device types should be noted within this field. For example, tests that are mandatory only for multi-subscriber ONUs are classified as “Mandatory for multiple user port devices”.

Unit Under Test

ONU

Requirement Description

List of requirements from the appropriate specification(s) that are applicable for this test. Note: A test case should test as small a set of requirements as is practical.

Test Objective

Succinct description of the test purpose

Test Configuration

Preconditions description if needed

Succinct description of the test configuration like GEM port/TCONT usage, VIDs, P-bit, etc. A test configuration schematic may also be used to add clarity to the test configuration description.

Test Procedure

Description of the test procedure considering that OMCI verification is part of the test procedure but described in a dedicated section

OMCI Procedure Details

Pointer to a specific annex with OMCI Implementation description (List of impacted ME and messages exchanges) Not required for interoperability tests.

Pass/Fail Criteria

A detailed description of the criteria upon which to base a pass/fail determination.

Remarks

Description of any particular observations that might affect the test result

Annex B: OMCI Procedure Details (obsolete)

This Annex was made obsolete.

Reference to OD-283 and OD-284 and OMCI sequences can be found in the clause **4.3 OMCI Messages**

Annex C: OMCI Scrambler Principle of Operation

The OMCI scrambler operation used by the OLT Emulator for ONU conformance testing shall operate with respect to the following common principles and rules:

- Scrambler shall randomly scramble the order of the OMCI requests with respect to the ordering rules as defined in Appendix II section 3.
- Splitting of composite requests is however not considered in the OMCI scrambler
- Scrambler shall randomly scramble the order of the OMCI messages and requests as long as there is no interdependency between attributes within MEs, as compliant with the "Interdependent Attribute Handling" paragraph in ITU-T G.988 Clause 9.
- It's not allowed to CREATE an ME instance which is implicitly linked to an instance of another ME through an identical ME ID without creating the linked ME instance first.

Annex D: OMCI Scrambler Example Implementation

```
import java.io.*;
import java.util.Scanner;

class OMCIcommand {
    public String comment;
    public String source;
    public String type;
    public String cmd;
    public String MEID;
    public String[] attr;
    public String[] attrName;
    public String[] attrValue;
    public int order;
}

public class OMCI_Scrambler {

    public static void main(String[] args) throws IOException {
        Scanner s = null;
        FileWriter w = null;
        FileWriter log = null;
        String Line = null;
        String Temp = null;
        String[] TableAttr = null;
        int MaxCmdCnt = 1024;
        OMCIcommand[] Commands = new OMCIcommand[MaxCmdCnt];
        String LogStr = new String();
        String commandTemp = new String();
        int row = 0;
        int n = 0;
        int i = 0;
        int j = 0;
        int cand;
        int position = 1;
```

```
int loopcnt = 0;

String Attrboundary = ",";
String ErrLogName = "errLog.txt";

if(0 == args.length)
{
    System.out.println("pls input the sorce file name with .txt");
    return;
}

try {
    s = new Scanner(new BufferedReader(new FileReader(args[0].toString())));
    // s.useDelimiter("\\\\)(\\n|\\f|\\r|\\t)*;");
    s.useDelimiter(";");
    while (s.hasNext()) {
        row++;
        Line = s.next().trim();
        if (Line.contains("//"))
        {
            commandTemp = Line.split("//")[1].trim();
        }

        Line = Line.split("//")[0];
        if (!Line.isEmpty()) {

            /* Line has no '(' or ')'; skip and log err */
            if ((!Line.contains("(") || (!Line.contains(")")))) {
                try {
                    log = new FileWriter(ErrLogName, true);
                    // log error and return;
                    LogStr = row + "      Attrs Not Find '(' or ')'\n\r";
                    System.out.println(LogStr);
                    log.append(LogStr);

                } finally {
                    if (log != null) {
```

```
        log.close();
    }
}

continue;
}

/* TableAttr input format check */
if (Line.contains("[") {
    /*
     * if tableAttr different counters of '[' and ']',skip
     * and log err
     */
    boolean flag = false;
    if (Line.split("\\[").length != Line.split("\\]").length) {
        try {

            log = new FileWriter(ErrLogName, true);
            // log error and return;
            LogStr = row
                + "      TableAttr counter of '[' different form ']'\\n\\r";
            System.out.println(LogStr);
            log.append(LogStr);
        } finally {
            if (log != null) {
                log.close();
            }
        }

        continue;
    }

    Temp = Line.substring(Line.indexOf('[', Line
        .lastIndexOf(']') + 1);
    TableAttr = new String[Temp.split("\\]").length];
    TableAttr = Temp.split("\\]");
```



```
    for (i = 0; i < TableAttr.length; i++) {
        if (TableAttr[i].contains(",")) {
            try {
                log = new FileWriter(ErrLogName, true);
                // log error and return;
                LogStr = row
                    + "      TableAttr Find ','\n\r";
                System.out.println(LogStr);
                log.append(LogStr);
                flag = true;
                break;
            } finally {
                if (log != null) {
                    log.close();
                }
            }
        }
    }

    if (flag) {
        continue;
    }

}

if (n >= MaxCmdCnt) {
    System.out.println("too many cmds to process !!");
    return;
}

Commands[n] = new OMCIcommand();

if(!commandTemp.isEmpty())
{
    Commands[n].comment = "//" + commandTemp.trim();
    commandTemp = "";
}
```

```
    }
    else
    {
        Commands[n].comment = "";
    }

    Commands[n].order = 0;
    Commands[n].source = Line;

    Commands[n].type = Line.split("\\(")[0].trim();

    Line = Line.split("\\(")[1];
    Line = Line.split("\\)")[0].trim();

    Commands[n].cmd = Line.split(Attrboundary, 3)[0].trim();
    Commands[n].MEID = Line.split(Attrboundary, 3)[1].trim();
    if (Line.split(Attrboundary, 3).length == 2) {
        Commands[n].attr = new String[0];
    } else {
        Line = Line.split(Attrboundary, 3)[2];
        Commands[n].attr = Line.split(Attrboundary);
    }
    int L = Commands[n].attr.length;
    Commands[n].attrName = new String[L];
    Commands[n].attrValue = new String[L];
    for (j = 0; j < L; j++) {
        Commands[n].attrName[j] = Commands[n].attr[j]
            .split("=")[0].trim();
        Commands[n].attrValue[j] = Commands[n].attr[j]
            .split("=")[1].trim();
    }

    n++;

}
else
{
```

```
    }

    }
} finally {
    if (s != null) {
        s.close();
    }
}

/* check if exists create cmd */
boolean errExist = false;
for (i = 0; i < n; i++) {
    if (Commands[i].cmd.compareToIgnoreCase("Set") == 0
        && (!Commands[i].MEID.contains("!"))) {
        for (j = 0; j < n; j++) {
            if ((Commands[j].cmd.compareToIgnoreCase("Create") == 0)
                && (Commands[j].MEID.compareTo(Commands[i].MEID) == 0)) {
                break;
            }
        }
    }

    if (j >= n) {
        errExist = true;

        /* err log */
        try {
            log = new FileWriter(ErrLogName, true);
            // log error and return;
            LogStr = row + "    Entity " + Commands[i].type
                + " MeID " + Commands[i].MEID
                + " has no create msg\n\r";
            System.out.println(LogStr);
            log.append(LogStr);
        }
    }
}
```

```
        } finally {
            if (log != null) {
                log.close();
            }
        }

    }

}

if (errExist) {
    return;
}

try {
    String FormatFileName = "FormattedOriginal.txt";
    w = new FileWriter(FormatFileName);

    for (i = 0; i < n; i++) {
        String Reconst = new String();

        if (Commands[i].comment.contains("//"))
        {
            Reconst = Commands[i].comment + "\r\n";
            w.write(Reconst);
        }

        Reconst = Commands[i].type + "(" + Commands[i].cmd
            + Attrboundary + Commands[i].MEID;
        for (j = 0; j < Commands[i].attr.length; j++) {
            Reconst = Reconst + ", " + Commands[i].attrName[j] + "="
                + Commands[i].attrValue[j];
        }
        Reconst = Reconst + "); \r\n";

        w.write(Reconst);
    }
}
```

```
    }  
  } finally {  
    if (w != null) {  
      w.close();  
    }  
  }  
}  
  
position = 1;  
loopcnt = 0;  
do {  
  int count = (int) (Math.random() * (n - position + 1));  
  j = -1;  
  cand = -1;  
  do {  
    j++;  
    if (Commands[j].order == 0) {  
      cand++;  
    }  
  } while (count != cand);  
  cand = j;  
  loopcnt++;  
  if (loopcnt > 1000) {  
    System.out.println("err happen, excessive looping !!");  
    try {  
      log = new FileWriter(ErrLogName, true);  
      // log error and return;  
      LogStr = " err!! check the errlog \n\r";  
      log.append(LogStr);  
    } finally {  
      if (log != null) {  
        log.close();  
      }  
    }  
  }  
  return;  
}
```

```
if (Commands[cand].order == 0) {
    boolean valid = false;
    /* This loop is the test that a SET comes after the corresponding CREATE */
    if ((Commands[cand].cmd.compareToIgnoreCase("Set") == 0)
        && (!Commands[cand].MEID.contains("!"))) {
        for (i = 0; i < n; i++) {
            if ((Commands[i].order > 0)
                && (Commands[i].cmd
                    .compareToIgnoreCase("Create") == 0)
                && Commands[i].MEID
                    .compareTo(Commands[cand].MEID) == 0) {
                valid = true;
                break;
            }
        }
    } else {
        valid = true;
    }

    if (valid) { /*This loop is the test that pointer Attr happen after the corresp. CREATE */
        for (j = 0; j < Commands[cand].attr.length; j++) {
            if (!Commands[cand].attrValue[j].contains("!")) {
                for (i = 0; i < n; i++) {
                    if ((Commands[cand].attrValue[j]
                        .compareTo(Commands[i].MEID) == 0)
                        && (Commands[i].cmd
                            .compareToIgnoreCase("Create") == 0)
                        && (Commands[i].order == 0)) {
                        valid = false;
                        break;
                    }
                }
            }

            if (valid == false) {
                break;
            }
        }
    }
}
```

```
    }

    }

    if (valid) { /*This loop is the test that VLAN table set happens after the corresp. VLAN SET's*/
        if ( (Commands[cand].type.compareTo("Ext_VLAN_Tagging_Opr_Config_Data") == 0)
            && (Commands[cand].attrName[0].contains("RcvFrameVLANTagOperTbl")) ) {
            for (i = 0; i < n; i++) {
                if ( (Commands[i].order == 0) &&
                    (Commands[i].type.compareTo("Ext_VLAN_Tagging_Opr_Config_Data") == 0) ) {
                    for (j = 0; j < Commands[i].attr.length; j++) {
                        if ((Commands[i].attrName[j].contains("InputTPID")) ||
                            (Commands[i].attrName[j].contains("OutputTPID"))) {
                            valid = false;
                            break;
                        }
                    }
                }
                if (valid == false) {
                    break;
                }
            }
        }
    }

    if (valid) {
        Commands[cand].order = position;
        position++;
        loopcnt = 0;
    }
} while (position <= n);

try {
    String ScrambledFileName = "ScrambledOriginal.txt";
    w = new FileWriter(ScrambledFileName);
    for (position = 1; position <= n; position++) {
```

```
        for (i = 0; i < n; i++) {
            if (Commands[i].order == position) {

                String Reconst = new String();
                Reconst = Commands[i].type + "(" + Commands[i].cmd
                    + ", " + Commands[i].MEID;
                for (j = 0; j < Commands[i].attr.length; j++) {
                    Reconst = Reconst + ", " + Commands[i].attrName[j]
                        + "=" + Commands[i].attrValue[j];
                }
                Reconst = Reconst + "); \r\n";
                w.write(Reconst);
            }
        }
    } finally {
        if (w != null) {
            w.close();
        }
    }

    /* create --> create + set */
    /* set --> set + set */
    /*{
        int currentN = n;
        for (i = 0; i < currentN; i++) {
            if ((Commands[i].cmd.compareToIgnoreCase("Create") == 0)
                || ((Commands[i].cmd.compareToIgnoreCase("Set") == 0) && (Commands[i].attr.length > 1))) {
                for (j = 0; j < Commands[i].attr.length; j++) {

                    if (n >= MaxCmdCnt) {
                        System.out.println("too many cmds to process !!");
                        continue;
                    }

                    Commands[n] = new OMCIcommand();
                    Commands[n].comment = "";
                }
            }
        }
    }
```



```
        Commands[n].order = 0;
        Commands[n].source = null;

        Commands[n].type = Commands[i].type;
        Commands[n].cmd = "Set";
        Commands[n].MEID = Commands[i].MEID;
        Commands[n].attr = new String[1];

        Commands[n].attrName = new String[1];
        Commands[n].attrValue = new String[1];

        Commands[n].attrName[0] = Commands[i].attrName[j];
        Commands[n].attrValue[0] = Commands[i].attrValue[j];

        n++;
    }
}
}
}

try {
    String FormatFileName = "FormattedSplitted.txt";
    w = new FileWriter(FormatFileName);

    for (i = 0; i < n; i++) {

        if (Commands[i].comment.contains("//"))
        {
            w.write(Commands[i].comment + "\r\n");
        }

        String Reconst = new String();
        Reconst = Commands[i].type + "(" + Commands[i].cmd
            + Attrboundary + Commands[i].MEID;
```

```
        for (j = 0; j < Commands[i].attr.length; j++) {
            Reconst = Reconst + ", " + Commands[i].attrName[j] + "="
                + Commands[i].attrValue[j];
        }
        Reconst = Reconst + "); \r\n";
        w.write(Reconst);
    }
} finally {
    if (w != null) {
        w.close();
    }
}

for(i = 0; i < n; i++)
{
    Commands[i].order = 0;
}

position = 1;
loopcnt = 0;
do {
    int count = (int) (Math.random() * (n - position + 1));
    j = -1;
    cand = -1;
    do {
        j++;
        if (Commands[j].order == 0) {
            cand++;
        }
    } while (count != cand);
    cand = j;
    loopcnt++;
    if (loopcnt > 100) {
        System.out.println("err happen, can't halase !!");
        try {
```

```
        log = new FileWriter(ErrLogName, true);
        // log error and return;
        LogStr = " err!! check the errlog \n\r";
        log.append(LogStr);

    } finally {
        if (log != null) {
            log.close();
        }
    }

    return;
}
if (Commands[cand].order == 0) {
    boolean valid = false;
    if ((Commands[cand].cmd.compareToIgnoreCase("Set") == 0)
        && (!Commands[cand].MEID.contains("!"))) {
        for (i = 0; i < n; i++) {
            if ((Commands[i].order > 0)
                && (Commands[i].cmd
                    .compareToIgnoreCase("Create") == 0)
                && Commands[i].MEID
                    .compareTo(Commands[cand].MEID) == 0) {
                valid = true;
                break;
            }
        }
    } else {
        valid = true;
    }

    if (valid) {
        for (j = 0; j < Commands[cand].attr.length; j++) {
            if (!Commands[cand].attrValue[j].contains("!")) {
                for (i = 0; i < n; i++) {
                    if ((Commands[cand].attrValue[j]
                        .compareTo(Commands[i].MEID) == 0)
```

```
        && (Commands[i].cmd
            .compareToIgnoreCase("Create") == 0)
        && (Commands[i].order == 0)) {
            valid = false;
            break;
        }
    }

    if (valid == false) {
        break;
    }
}

if (valid) {
    Commands[cand].order = position;
    position++;
    loopcnt = 0;
}
} while (position <= n);

try {
    String ScrambledFileName = "ScrambledSplitted.txt";
    w = new FileWriter(ScrambledFileName);
    for (position = 1; position <= n; position++) {
        for (i = 0; i < n; i++) {

            if (Commands[i].order == position) {
                String Reconst = new String();
                Reconst = Commands[i].type + "(" + Commands[i].cmd
                    + ", " + Commands[i].MEID;
                for (j = 0; j < Commands[i].attr.length; j++) {
                    Reconst = Reconst + ", " + Commands[i].attrName[j]
                        + "=" + Commands[i].attrValue[j];
                }
            }
        }
    }
}
```

```
        }
        Reconst = Reconst + "); \r\n";
        w.write(Reconst);
    }
}
} finally {
    if (w != null) {
        w.close();
    }
}*/
}
```

End of Broadband Forum Test Plan TP-247