

# MR-459

## Disaggregated BNG

Issue: 1

ISSUE DATE: October 2019

## Issue History

Issue Number	Issue Date	Issue Editor	Changes
1	October 2019	Kenneth Wan, Nokia	Original

Comments or questions about this Broadband Forum Marketing Report should be directed to [info@broadband-forum.org](mailto:info@broadband-forum.org).

**Editor** Kenneth Wan, Nokia

**Work Area Director(s)** David Sinicrope, Ericsson

**Contributors** Kenneth Wan, Nokia

**Table of Contents**

Executive Summary ..... 4

1 Disaggregated BNG Introduction ..... 5

2 Business Motivations ..... 5

3 Disaggregated BNG Architecture and interfaces..... 6

4 Timeline ..... 7

5 End Results..... 7

6 Terminology ..... 8

    6.1 References ..... 8

    6.2 Definitions ..... 8

    6.3 Abbreviations ..... 9

**List of Figures**

Figure 1: High Level Disaggregated BNG Architecture ..... 6

## Executive Summary

Broadband Forum (BBF) is defining the next evolution of the Broadband Network Gateway (BNG). By separating the control plane (CP) and user plane (UP) of the BNG, the disaggregated BNG (DBNG) offers new possibilities for both service providers and vendors. Service providers can now scale the CP and UP individually to match the market demand. Capital expense (CapEx) is optimized by avoiding under or over-utilizing resources. Operating expense (OpEx) is reduced as well by significantly simplifying operations. Compared to traditional BNGs which requires individual management, the DBNG can simplify management of all software upgrades, provisioning and rollout of services, and allocation of resources such as IP addresses. Conversely vendors can now innovate on the CP and the UP independently where compromises and tradeoffs were necessary when the BNG was designed as a single system. This paper describes the business motivation for DBNG and BBF standardization work on the DBNG architecture, interfaces and protocols.

# 1 Disaggregated BNG Introduction

BNG is an essential device that grants subscribers access to the internet. It provides critical subscriber management functions, such as: authentication, IP address assignment, bandwidth allocation, and accounting. The BNG started as a basic fixed line access aggregator (i.e aggregation of DSLAMs and OLTs) but has now evolved into a multi-access edge device terminating services from access types including: wireline, wireless, public Wi-Fi, and hybrid access. Over the past 20 years, the BBF continues to publish Technical Reports (TRs) to extend BNG's capabilities further.

Similarly, broadband services have evolved as well, starting from basic high speed internet service to now include: VoIP, IPTV, OTT video streaming, video game streaming, business VPN services, and many other IP services. As a result, the BNG is taking on both exponential subscriber and bandwidth growth which brings forth the following challenges:

- Over-utilizing a BNG
- Under-utilizing a BNG
- Operation challenge in managing and maintaining a geographically distributed BNG deployment
- Service provisioning across all BNGs and time to market new services

These challenges are faced by wireless operators as well. With a rapid increase of smart devices and proliferation of video traffic, 3GPP initiated the control user plane separation (CUPS) project. CUPS allows individual scaling of the control plane (CP) and the user plane (UP) to keep up with subscriber growth and subscriber bandwidth demands. The CUPS architecture also simplifies operations by maintaining a single user interface on the CP to manage all UPs. CUPS' proven success in the mobile core instigated wireline operators to look at CUPS applicability for the BNG. At BBF, both service providers and vendors also postulate that BNG CP and UP separation could obtain the same key benefits:

- Centralized management for service provisioning, operations, and management
- Flexible scaling of CP and UP to match the market demand

The BBF Access and Transport Architecture (ATA) group has already begun a project to revolutionize the BNG once again. Disaggregated BNG (DBNG) decouples the BNG CP and UP subscriber management function. Service providers can manage and deploy BNG in radical new ways. BNG vendors can innovate and develop the CP and the UP as separate system without having to compromise for either. The ATA group defines a DBNG solution that can: adapt to market demands, be extensible to take on new applications, improve time to market services, and simplify operations.

## 2 Business Motivations

### CAPEX savings:

Traditional BNG requires that both CP and UP be upgraded when either requires increase in scale. The DBNG solution offers a an entirely new deployment paradigm: 1) a choice to scale only either the CP or the UP, 2) a choice in choosing the platform to host the CP or the UP, and 3) independent CP or UP hardware upgrades. Service providers are now offered a wide variety of options to deploy the DBNG which can match closely with end customers' demands.

### OPEX savings:

The crucial DBNG advantage is its ability to simplify operations significantly. A common BNG deployment model is the distributed model where BNG are geographically dispersed. Each BNG in this model is a standalone system, implying that commissioning, service provisioning, subscriber management, and software maintenance all must be done separately. The DBNG provides a centralized control plane function managing multiple UPs. The DBNG would aggregate these UPs which traditionally would be standalone BNG system and manage them through a single control plane function. Limited resources, such as IP address pools, no longer needs pre-planning to size the allocation. DBNG CP centralizes resources and assigns resources to UP dynamically, thereby reducing the time for pre-planning and even sometimes entirely removing the pre-planning phase. DBNG can increase efficiency in resource usage. Operations

such as software upgrade for the control plane can be conducted at a centralized location once instead of multiple times on individual BNGs.

**Multi-vendors inter-operability:**

Standardization of DBNG architecture, interfaces and protocols allows interoperability between vendors' control plane and user plane elements. Service Providers can compare different products and leverage a multi-vendor environment for financial or technical advantages. Vendors, on the other hand, can be assured of one-time development cost with the standardization of DBNG architecture, interfaces, and protocol.

**Time to market Services:**

The DBNG centralized control plane function provides a single point for service provisioning. New service offering can be expediently rolled out to all subscribers, improving the time to market and market reach.

**Technology assurance:**

For operators of converged networks especially, DBNG utilizes the Packet Forwarding Control Protocol (PFCP), the same protocol that is used for other wireline access technologies such as the BBF defined Aggregate Gateway Function (AGF) and 3GPP 5GC converged core. This commonality simplifies training and operations as the same protocol is reused for different wireline elements. Wireline-only operators can be reassured that the defined protocol for DBNG allows for convergence if the opportunity arises.

### 3 Disaggregated BNG Architecture and interfaces

The BBF DBNG project focuses on separating the subscriber management function between CP and UP. The DBNG maintains all BBF well-defined BNG functionalities.

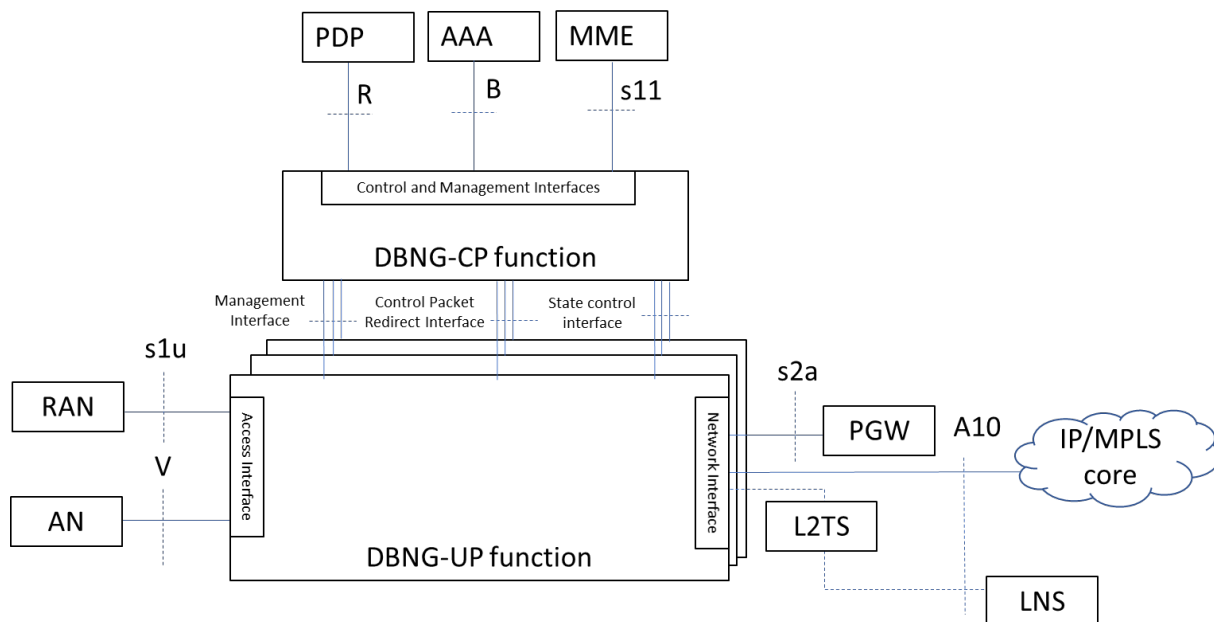

**Figure 1: High Level Disaggregated BNG Architecture**

A single chassis BNG traditionally used an internal proprietary method for CP and UP communication. By separating the CP and UP, the DBNG project defines three new standardized interfaces and their respective standardized protocols for CP and UP communication.

- Management Interface

- An interface which allows the DBNG-CP to manage the DBNG-UP utilizing YANG data models.
- State Control interface
  - An interface which utilizes PFCP to program the forwarding state of each Subscriber Session
- Control Packet Redirect Interface
  - An interface that redirect subscriber control packets, such as DHCP and PPPoE, between the DBNG-CP and DBNG-UP

## 4 Timeline

BBF plans to complete WT-459 in the coming year which will include DBNG standard architecture, call flows, information models, and PFCP information element (IE) extensions for the state control interface. WT-459 will continue to evolve with new revisions taking on both existing and future BNG functional use cases.

## 5 End Results

The BNG deployed in the market today is a multi-access device supporting a wide variety of IP services. It is connecting ever more subscribers through new access types and bandwidth demand is at a new high with new video services. To address the growth, service providers are often faced with only a new chassis installation option which requires individual commissioning, maintenance, and management. At the same time subscriber growth and bandwidth demand are not always symmetrical, therefore, CP or UP might be left under-utilized.

The DBNG looks to address all the traditional BNG limitations. Service providers would no longer be limited to a hardware “boxed” solution. The DBNG architecture eliminates inefficient use of resources and simplifies operations which would translate to direct CapEx and OpEx savings. Service providers can leverage the flexibility of independent DBNG CP and UP scaling, to react faster to the subscriber growth and keep up with the increasing customer bandwidth demand. At the same time, utilize single user plane to manage all UP instances and reduce the time to market new broadband services.

BBF is standardizing the architecture, interfaces and its respective protocols for the DBNG. Call flows are being defined for each broadband application and can be used as design reference for vendors. The work includes standardizing the DBNG state control interface PFCP information exchange and information element (IE) extensions. BBF continues to update and add new call flows and PFCP information exchanges and IEs, as BNG applications continues to evolve and as new broadband services emerges.

This document will continue to track and update with the progress of the BBF DBNG project.

## 6 Terminology

### 6.1 References

The following references are of relevance to this Marketing Report. At the time of publication, the editions indicated were valid. All references are subject to revision; users of this Marketing Report are therefore encouraged to investigate the possibility of applying the most recent edition of the references listed below.

A list of currently valid Broadband Forum Technical Reports is published at [www.broadband-forum.org](http://www.broadband-forum.org).

Document	Title	Source	Year
[1]	<i>WT-459, Control and User Plane Separation for a Disaggregated BNG</i>	Broadband Forum	2019
[2]	<i>TR-101 Issue 2 Migration to Ethernet-Based Broadband Aggregation</i>	Broadband Forum	2011
[3]	<i>TR-178 Issue 2 Multi-Service Broadband Network Architecture and Nodal Requirements</i>	Broadband Forum	2017
[4]	<i>TR-291 Nodal Requirements for interworking between Next Generation Fixed and 3GPP Wireless Access</i>	Broadband Forum	2014
[5]	<i>TR-321 Public WiFi</i>	Broadband Forum	2015
[6]	<i>TR-348 Hybrid Access</i>	Broadband Forum	2016
[7]	<i>TR-384 Cloud Central Office Reference Architecture Framework</i>	Broadband Forum	2018
[8]	<i>3GPP TS 29.244 v16.0.0 3rd Generation Partnership Project; Technical Specification Group Core Network and Terminals; Interface between the Control Plane and User Plane Nodes; Stage 3 (Release 16)</i>	3GPP	2019

### 6.2 Definitions

The following terminology is used throughout this document.

<b>AGF</b>	A function which is added to a wireline access network and allows connectivity to the 5G core.
<b>BNG</b>	An Ethernet centric IP Edge Router where bandwidth and QoS policies may be applied. It is the aggregation point for the user traffic. It provides aggregation capabilities (e.g. IP, PPP, Ethernet) between the access network and the NSP or ASP. Beyond aggregation, it can also support policy management and IP QoS in the access network. (TR-178)



**CUPS** CUPS stands for Control and User Plane Separation. This enables flexible network deployment and operation, by distributed or centralized deployment and the independent scaling between control plane and user plane functions - while not affecting the functionality of the existing nodes subject to this split. (This definition is based on 3gpp.org/cups)

## 6.3 Abbreviations

This document uses the following abbreviations:

3GPP	3 <sup>rd</sup> Generation Partnership Project
5GC	5G core
AGF	Aggregator Gateway Function
ATA	Access and Transport Architecture
BBF	Broadband Forum
BNG	Broadband Network Gateway
CapEx	Capital Expense
CP	Control Plane
CUPS	Control and User Plane Separation
DBNG	Disaggregated BNG
DHCP	Dynamic Host Configuration Protocol
DSLAM	Digital Subscriber Line Access Multiplexer
IE	PFCP information element
IP	Internet Protocol
MD	Marketing Draft
MR	Marketing Report
OLT	Optical Line Termination
OpEx	Operating Expense
OTT	Over the top (media service)
PFCP	Packet Forwarding Control Protocol
PPPoE	Point to Point Protocol over Ethernet
TR	Technical Report
UP	User Plane
VoIP	Voice over IP
VPN	Virtual Private Network
WA	Work Area
WT	Working Text
YANG	Yet Another Next Generation

## Notice

The Broadband Forum is a non-profit corporation organized to create guidelines for broadband network system development and deployment. This Marketing Report has been approved by members of the Forum. This Marketing Report is subject to change. This Marketing Report is copyrighted by the Broadband Forum, and all rights are reserved. Portions of this Marketing Report may be copyrighted by Broadband Forum members.

## Intellectual Property

Recipients of this Marketing Report are requested to submit, with their comments, notification of any relevant patent claims or other intellectual property rights of which they may be aware that might be infringed by any implementation of this Marketing Report, or use of any software code normatively referenced in this Marketing Report, and to provide supporting documentation.

## Terms of Use

### 1. License

Broadband Forum hereby grants you the right, without charge, on a perpetual, non-exclusive and worldwide basis, to utilize the Marketing Report for the purpose of developing, making, having made, using, marketing, importing, offering to sell or license, and selling or licensing, and to otherwise distribute, products complying with the Marketing Report, in all cases **subject to the conditions set forth in this notice and any relevant patent and other intellectual property rights of third parties (which may include members of Broadband Forum)**. This license grant does not include the right to sublicense, modify or create derivative works based upon the Marketing Report except to the extent this Marketing Report includes text implementable in computer code, in which case your right under this License to create and modify derivative works is limited to modifying and creating derivative works of such code. For the avoidance of doubt, except as qualified by the preceding sentence, products implementing this Marketing Report are not deemed to be derivative works of the Marketing Report.

### 2. NO WARRANTIES

THIS MARKETING REPORT IS BEING OFFERED WITHOUT ANY WARRANTY WHATSOEVER, AND IN PARTICULAR, ANY WARRANTY OF NONINFRINGEMENT IS EXPRESSLY DISCLAIMED. ANY USE OF THIS MARKETING REPORT SHALL BE MADE ENTIRELY AT THE IMPLEMENTER'S OWN RISK, AND NEITHER THE BROADBAND FORUM, NOR ANY OF ITS MEMBERS OR SUBMITTERS, SHALL HAVE ANY LIABILITY WHATSOEVER TO ANY IMPLEMENTER OR THIRD PARTY FOR ANY DAMAGES OF ANY NATURE WHATSOEVER, DIRECTLY OR INDIRECTLY, ARISING FROM THE USE OF THIS MARKETING REPORT.

### 3. THIRD PARTY RIGHTS

Without limiting the generality of Section 2 above, BROADBAND FORUM ASSUMES NO RESPONSIBILITY TO COMPILER, CONFIRM, UPDATE OR MAKE PUBLIC ANY THIRD PARTY ASSERTIONS OF PATENT OR OTHER INTELLECTUAL PROPERTY RIGHTS THAT MIGHT NOW OR IN THE FUTURE BE INFRINGED BY AN IMPLEMENTATION OF THE MARKETING REPORT IN ITS CURRENT, OR IN ANY FUTURE FORM. IF ANY SUCH RIGHTS ARE DESCRIBED ON THE MARKETING REPORT, BROADBAND FORUM TAKES NO POSITION AS TO THE VALIDITY OR INVALIDITY OF SUCH ASSERTIONS, OR THAT ALL SUCH ASSERTIONS THAT HAVE OR MAY BE MADE ARE SO LISTED.

The text of this notice must be included in all copies of this Marketing Report.

End of Broadband Forum Marketing Report MR-459