



APP NOTE

# CloudCO-APPN-463: EasyMesh Cloud Controller

June 2020

Editor: Ken Kerpez (ASSIA Inc.)  
Supporting Company: ASSIA Inc.

# Summary/Objective

[EasyMesh™](#) is specified by the Wi-Fi Alliance to provide management of multiple Wi-Fi Access Points (APs) within a premises (multi-AP). Multiple APs can extend good Wi-Fi coverage at all locations across an entire premises if the multi-AP network is properly configured by an EasyMesh controller. Current EasyMesh controllers run within devices located in the premises and directly connected to the premises LAN.

This application note describes how to disaggregate EasyMesh by instantiating and running a cloud-based Wi-Fi EasyMesh controller within a CloudCO domain instance. Note that a cloud-based EasyMesh controller is being considered by the [BBF OB-MAP project](#) and by the Wi-Fi Alliance.

Interactions for creating and running the EasyMesh management service are provided in this application note.

## Assumptions and Preconditions

1. The CloudCO Domain instance is already fully bootstrapped.
2. The Network Elements consist of in-premises PNFs which support EasyMesh agents.
3. The physical connectivity between in-premises PNFs and the BAA has been established.
4. VNFs for the EasyMesh controller are available and ready for onboarding.
5. External orchestration / OSS is able to provide instructions and policies for configuring EasyMesh, and to provide addressing and credentials for connecting to the equipment.

# Description of the System

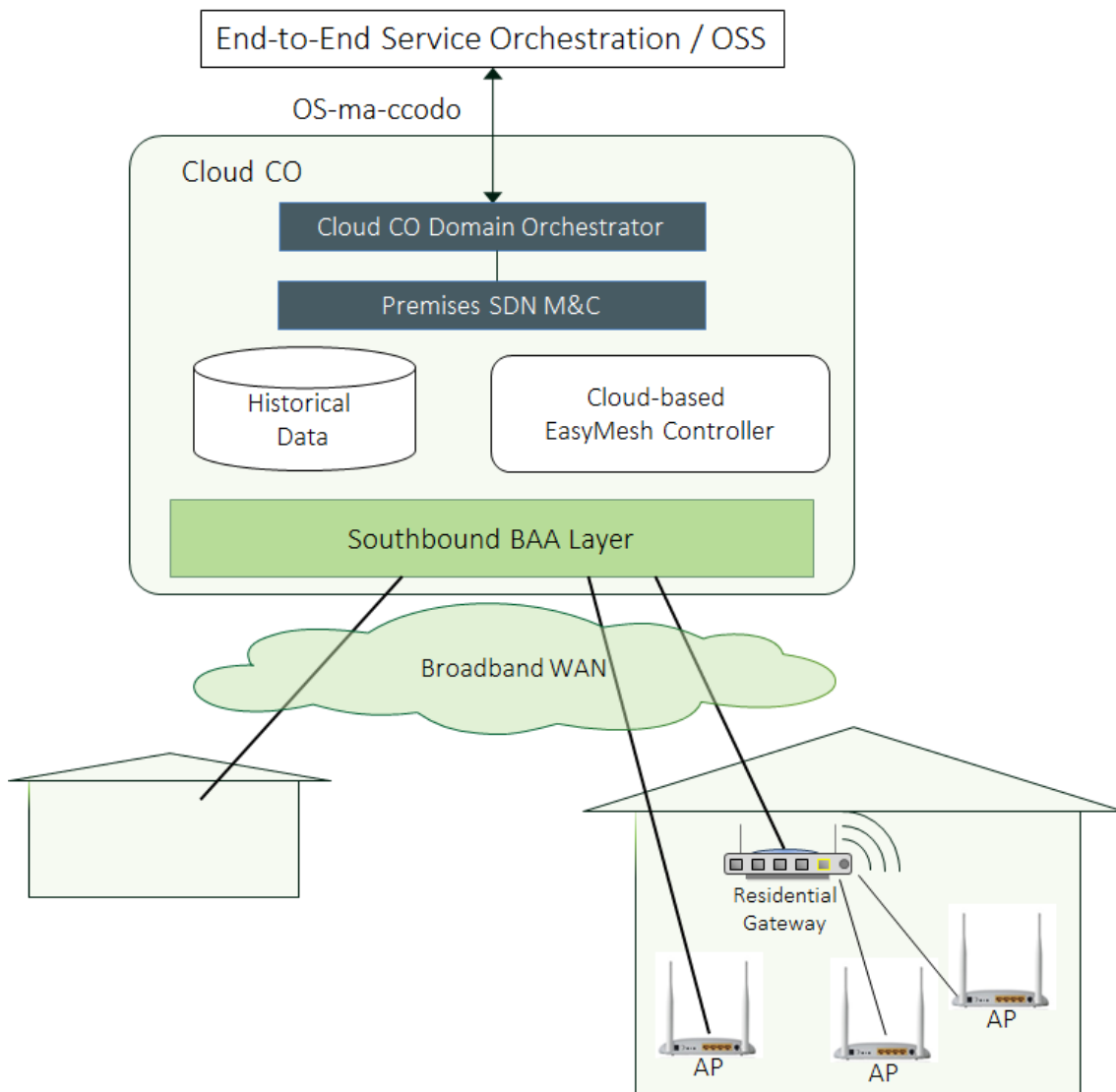

The above figure shows that multiple premises connect to a Cloud CO, and expands on one of these premises to show details of the Multi-AP EasyMesh system. An EasyMesh controller controls some number of multi-AP APs. Each AP has a multi-AP agent. The Residential Gateway in the figure provides a means to proxy local EasyMesh Ethernet messages (TLVs) on the premises LAN to and from a format suitable for broadband WAN transport. Messages may also be sent to and from the AP/agent directly to the cloud-based EasyMesh controller. The Residential Gateway may also host a local EasyMesh controller, for use in conjunction with the cloud-based EasyMesh controller or when the cloud-based EasyMesh controller is unreachable.

There are different WAN transport options for EasyMesh messages:

1. Transport local MAP Ethernet TLVs directly through a layer-2 tunnel (e.g., using VLANs, GRE, or VXLAN),
2. Convert MAP Ethernet TLV parameters into messages sent via a Message Transfer Protocol (MTP). The high-level API, data model, or similar represents the MAP data which is transported across the WAN with an MTP such as [USP](#).

Both options deliver the same message content and are simply called the G-interface here.

# Components

Component Framework Name	Component Description
CCO DO	Cloud CO Domain Orchestrator TR-384, WT-411
Premises SDN M&C	Premises SDN Management and Control: TR-384, WT-411, WT-413 - Provides SDN Management and Control of the RG and AP/agents via the BAA
VIM	Virtualized Infrastructure Manager: WT-411, ETSI NFV - Controls the NFVI, deploys VNFs and interconnects them.
BAA	Broadband Access Abstraction layer: TR-384, WT-411, WT-413: Aggregates and virtualizes access to DPUs and vOLT PNFs.
RG	Residential Gateway, Premises PNF
EasyMesh Controller	Controller of the EasyMesh multi-AP Wi-Fi network within a premises.

# Actors

Actor Name	Actor Description	Actions at CCO Perimeter (CCO DO NBI, User action)
Broadband service provider	The Broadband service provider provides broadband service. Assumed to also be the Wi-Fi operator here.	Installs and operates broadband service. Responsible for operation of the in-premises Wi-Fi
Service User	The broadband/Wi-Fi consumer	User accesses the Internet over Wi-Fi

# Interactions

## Interaction 1: Instantiate cloud-based EasyMesh service

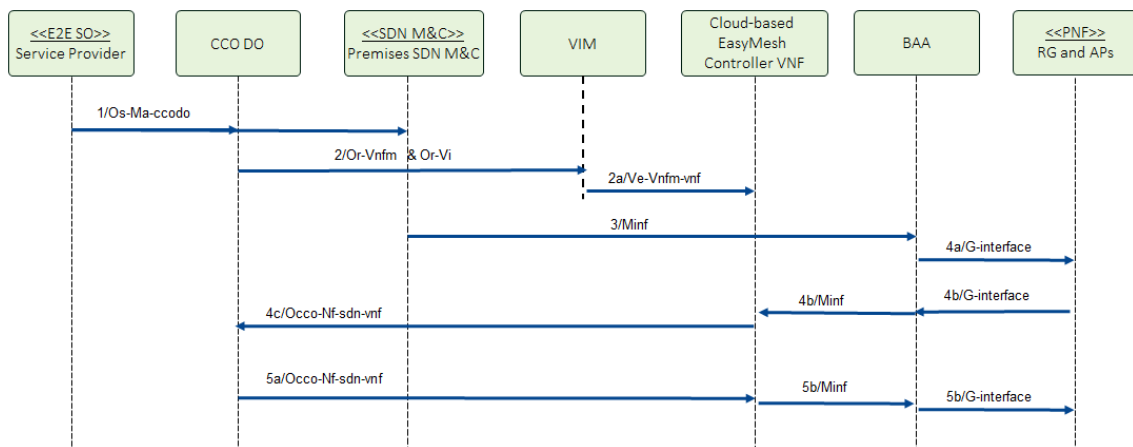

1. CCO DO receives a request for cloud-based Wi-Fi control from external orchestration / OSS.

- a. The request identifies and contains addresses to communicate to the premises RG and APs, and sometimes also to external NMS/OSS.
  - b. This request is passed from CCO DO to the Premises SDN M&C.
2. CCO DO/Premises SDN M&C requests the VIM to instantiate the cloud-based EasyMesh controller VNF.
  - a. VIM instantiates the cloud-based EasyMesh controller.
3. CCO DO/Premises SDN M&C provides equipment identification/addresses to the BAA so the BAA can connect to the RG and APs.
4. BAA creates Southbound Interface(s) (SBI) to the RG and APs across the G-interfaces or via layer-2 tunnels.
  - a. BAA is now enabled to receive a Northbound API call for a certain action from the cloud-based EasyMesh controller and translate this into the proper messages which are sent on its Southbound interface. For example, messages from the cloud-based EasyMesh controller issue instructions to the APs.
  - b. The RG and APs acknowledge messages from the cloud-based EasyMesh controller.
  - c. CCO DO and Premises SDN M&C are notified that messaging is established.
5. CCO DO and Premises SDN M&C instantiates the EasyMesh diagnostics and control service instance.
  - a. Algorithmic thresholds for channel change and client steering, frequencies for reporting and other EasyMesh policies, are sent to the cloud-based EasyMesh controller as determined by defaults and the instructions in the original request 1. from external orchestration/OSS.
  - b. Messages are sent from the cloud-based EasyMesh controller through the BAA to the APs to configure their EasyMesh policies of operation.

## Interaction 2: Control the in-premises multi-AP Wi-Fi network with the cloud-based EasyMesh controller

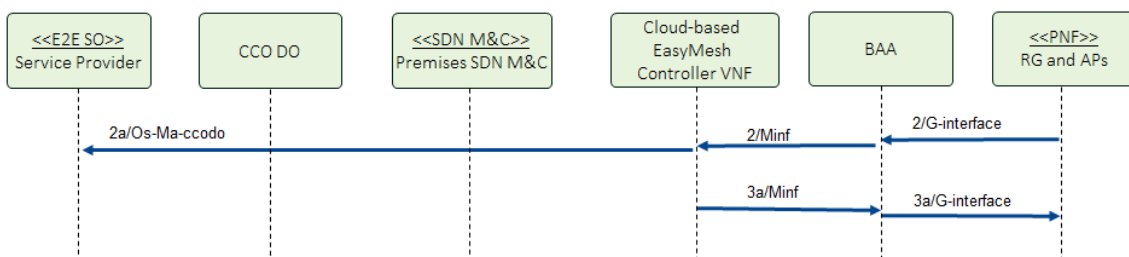

1. Interaction 1 has occurred and the cloud-based EasyMesh controller is communicating with the RG and APs.
2. The cloud-based EasyMesh controller collects Wi-Fi [data elements](#) metrics and other diagnostics data from the APs through the BAA.
  - a. These data are forwarded to external Wi-Fi management NMS/OSS via the CCO DO/Premises SDN M&C so that the Broadband service provider can diagnose in-premises Wi-Fi.
3. The cloud-based EasyMesh controller controls the multi-AP network
  - a. Messages are sent from the cloud-based EasyMesh controller through the BAA to the APs, for example to instruct the APs to optimize multi-AP Wi-Fi by performing channel change, client steering and other control actions.

# Success Criteria

Interaction 1:

1. Cloud-based controller is successfully instantiated and can communicate with the RG and all the multi-AP capable APs in the in-premises Wi-Fi network.

Interaction 2:

1. Wi-Fi [data elements](#) metrics and other diagnostics data are provided to external orchestration / OSS so that the Broadband service provider can diagnose in-premises Wi-Fi.
2. The in-premises Wi-Fi network is configured, on an on-going basis, to provide good Wi-Fi coverage and performance.
3. EasyMesh control proceeds without too much message delay, so that applications run seamlessly, such as providing continuous conversation during a voice call with a client steering event.