



APP NOTE

## **CloudCO-APPN-446: ONAP Integration for Residential Broadband HSIA Service**

June 2020

Editor: Tim Carey (Nokia)

Contributors: David Perez Caparros (Swisscom), Victor Gao (Huawei), Heaven Gaobo (Huawei)

Supporting Companies: Swisscom, Nokia, Huawei

# Executive Summary

This application note describes how to establish a residential Broadband High Speed Internet Access Service within a CloudCO Instance, using the [Open Network Automation Platform \(ONAP\)](#) as the CloudCO Domain Orchestrator. The application note is aligned with ONAP's [Broadband Services \(BBS\) Use Case](#) in the Dublin release.

## Summary/Objective

This application note establishes a HSIA service for a subscriber within a CloudCO using [ONAP](#) as the CloudCO Domain Orchestrator.

The following interactions are included in this application note:

1. Zero-touch creation and activation of the customer facing HSIA service for residential Broadband subscribers. The CPE used is an ONT that contains the residential gateway functionality.
2. Zero-touch relocation of the ONT that results in a change of the ONT's PON attachment point and results in the subscribers HSIA service being moved to the subscriber's new locations. This is called the Nomadic ONT scenario in the ONAP BBS use case.

## Assumptions and Preconditions

1. ONAP provides the E2E Service Orchestration, CloudCO Domain Orchestration and management and control of the NFVI functionality (VIM, DC SDN M&C).
2. As ONAP performs resource orchestration and management interfacing with the VIM, VNFs are deployed as ONAP VNFs.
3. While the ONAP BBS Use Case places the Edge functionality in the service provider's centralized Data Center, this application note places the Edge functionality within the CloudCO's NFVI infrastructure.
4. The ONAP BBS Use Case includes an Optical Distribution Network (ODN) between the ONT and the OLT PON UNI. This network is a passive network and is not included in this application note.
5. The following HSIA Infrastructure Services have been established:
  - o OLT is onboarded to the Access BAA layer and Access SDN M&C and communicating with the BAA layer
  - o Management plane connectivity between the BAA layer and the Access SDN M&C
  - o Management plane connectivity between the Edge VNFs (i.e., AAA, DHCP, vBNG) and the Edge SDN M&C
  - o Management plane connectivity between ONAP and the Access SDN M&C
  - o Management plane connectivity between ONAP and the Edge SDN M&C
  - o User plane connectivity between the OLT and vBNG
  - o User plane connectivity between the vBNG and AAA/DHCP VNFs.

## System Context

In this application note, ONAP provides the E2E Service Orchestration, CloudCO Domain Orchestration and management and control of the NFVI functionality (VIM, DC SDN M&C).

The interaction between ONAP and CloudCO is via the CloudCO's Access and Edge SDN M&C functions. The ONAP components to which the functions interface are the:

- SDN-C: This component is the SDN controller that is responsible for maintaining the configuration of the service's network resources. The interface is bi-directional as some notifications sent by the Access SDN M&C are used by the ONAP SDN-C component to maintain the configuration of the network resources used in ONAP (e.g., topology updates).
- DCAE: This component is the Data Collection Analytics and Events component that receives various events (e.g., faults, performance monitoring, state changes) that affect the services and network resources in ONAP.

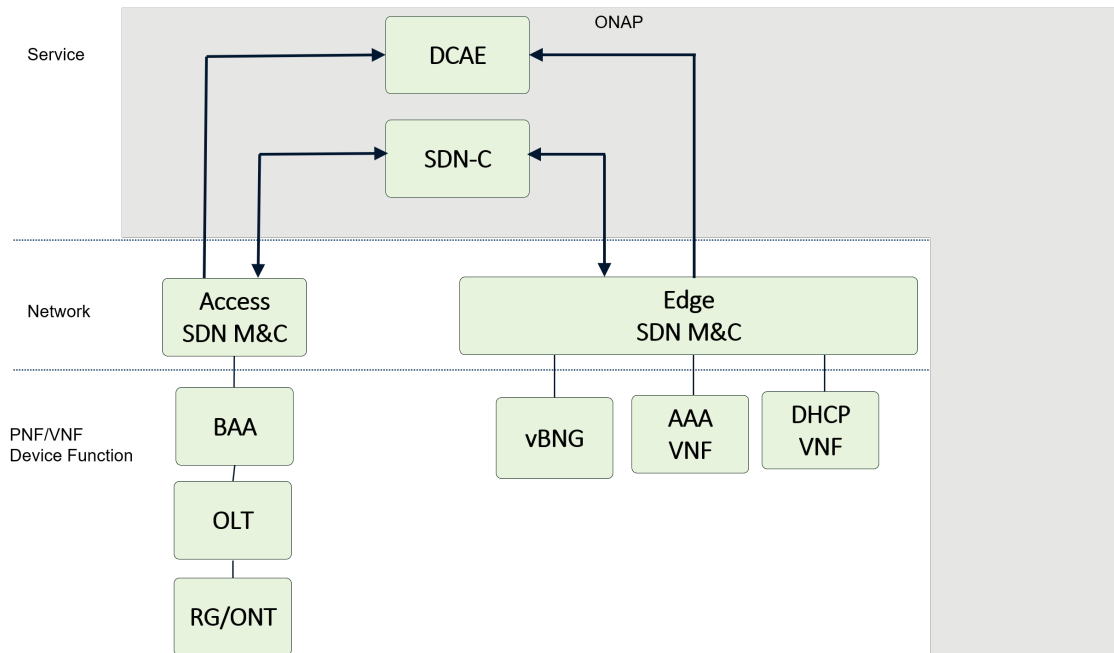

## Description of the System

The BBS Use Case HSIA Service is a customer faces service (CFS) that is comprised of HSIA Access and HSIA Internet resource facing services (RFS). The HSIA Access RFS is further comprised of the ONT and Access Connectivity RFS in this application note. The ODN RFS is not used in this application note as the ONT is directly attached to the PON UNI. The HSIA Internet RFS is composed of an Internet profile RFS.

The system description diagram below depicts the placement of the various services in the context of the Access and Edge domains. The HSIA CFS is instantiated per subscriber while the HSIA Infrastructure Services (depicted as the NFVI tunnel - user or control planes) are deployed to support many HSIA CFSs.

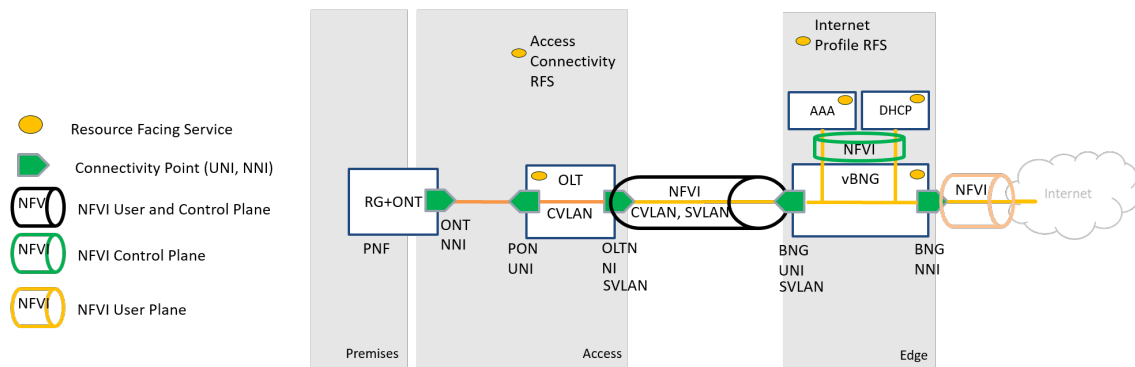
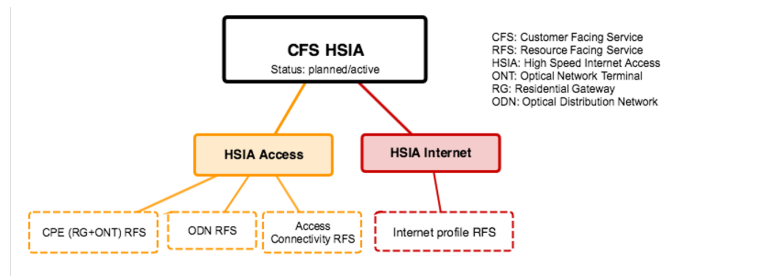

The BBS Use Case assumes that the HSIA Infrastructure exists prior to instantiation of the HSIA CFS. As such this application note also assumes that the NFVI is already provisioned to allow the OLT access to the AAA, BNG and DHCP VNFs. Likewise, the vBNG is connected to the Internet drain.

In the BBS Use Case for zero-touch creation and activation for a HSIA CFS, when the HSIA CFS service is created, the service information is maintained by ONAP until, the Access SDN M&C notifies ONAP that an ONT has requested registration using the ONAP PNF registration event.

Upon reception of the PNF registration event, ONAP configures the network resources for creation of the HSIA CFS by requesting the:

- Access SDN M&C to setup the user plane from the Access UNI (C-VLAN) to the Access NNI (S-VLAN)
- Edge SDN M&C to configure the AAA VNF with the enduser (tenant) credentials and the DHCP VNF with the enduser (tenant) addresses and policies that will be used within the RG function of the ONT.

When the RG function of the ONT is able to authenticates with the network using the information in DHCP option 82, the Edge SDN M&C notifies ONAP of the results of the authentication and if successful, ONAP activates the HSIA CFS within ONAP by setting the HSIA CFS state to either be active or inactive. The Edge SDN M&C uses the information from the DHCP option 60 to identify the ONT PNF in event messages (e.g., CPE Authentication).

In the BBS Use case for zero-touch ONT relocation for a HSIA CFS, the Access SDN M&C is able to detect that the attachment point (PON UNI) that a particular ONT previously was attached to had changed, causing the Access SDN M&C to send a PNF registration event for the new attachment point to ONAP.

Upon reception of the PNF registration event for the new attachment point, ONAP re-configures the network resources of the HSIA CFS to all the user plane to originate with the new attachment point. Like the original HSIA CFS activation, the HSIA CFS is considered active when the ONT has successfully authenticated with the Edge network.

# Components

Component Framework Name	Component Description
ONAP:SDN-C	ONAP SDN Controller responsible for the configuration and control of the network resources associated with the Access Connectivity and Internet profile RFS via the Access and Edge SDN M&C elements.
ONAP: DCAE	ONAP Data Collection, Analysis and Event component responsible for receiving event notifications (e.g., fault, state-change, PNF registration, CPE authentication) and performance monitoring data from the Access and Edge SDN M&C elements.
Edge SDN M&C	Edge SDN Management and Control: TR-384, WT-411, TR-413 - Provides SDN Management and Control of the routing user plane within the vBNG VNF and RG control plane functions, as well as control plane functions that have been virtualized such as DHCP and AAA VNFs.
Access SDN M&C	Access SDN Management and Control: TR-384, WT-411, TR-413 - Provides SDN Management and Control of the ONT functions and OLT via the BAA layer.
BAA	Broadband Access Abstraction layer: TR-384, WT-411, TR-413: Aggregates and virtualizes access to ONT and OLT PNFs.
ONT	Access PNF that contains the ONT NNI.
RG	Premises PNF function integrated in the ONT.
OLT	Access PNF that contains the PON UNI and OLT NNI.
vBNG	BNG VNF responsible for user plane forwarding from the BNG UNI to the Internet drain. Also responsible for control plane forward of the RG/ONT and OLT control plane to the respective control plane VNFs (e.g., AAA, DHCP).
AAA	AAA VNF responsible for authenticating the RG function of the ONT using the information obtained from the DHCP option 82.
DHCP	DHCP VNF responsible for IP address assignment for the ONT/RG as well as providing identification of the ONT PNF using the information contained within DHCP option 60 for DHCP requests from the ONT/RG.

# Actors

Actor Name	Actor Description	Actions at CCO Perimeter (SDN M&C NBI, User action)
Service Provider	The service provider designs and deploys the HSIA CFS and associated RFS services in ONAP.  The service provider creates the HSIA CFS service instance.	1. Once the HSIA CFS is created within ONAP, the actions to activate and relocate the service are zero-touch.
Service User	The service user attaches the ONT to the port within the premises, causing a zero-touch activation or relocation flow to occur.	1. User connects the ONT to the network either for the first time or during a relocation event.

# Interactions

The interactions described in this section is based on [flow diagrams from the ONAP BBS Use Case](#) that describes the interactions within ONAP, CloudCO SDN M&C elements and the CloudCO network resources. The only addition in the Application Note is the BAA layer which provides the virtualization of the OLT and ONT.

## **Interaction 1: Create and Activate HSIA Service for ONAP Integration for Residential Broadband HSIA Service**

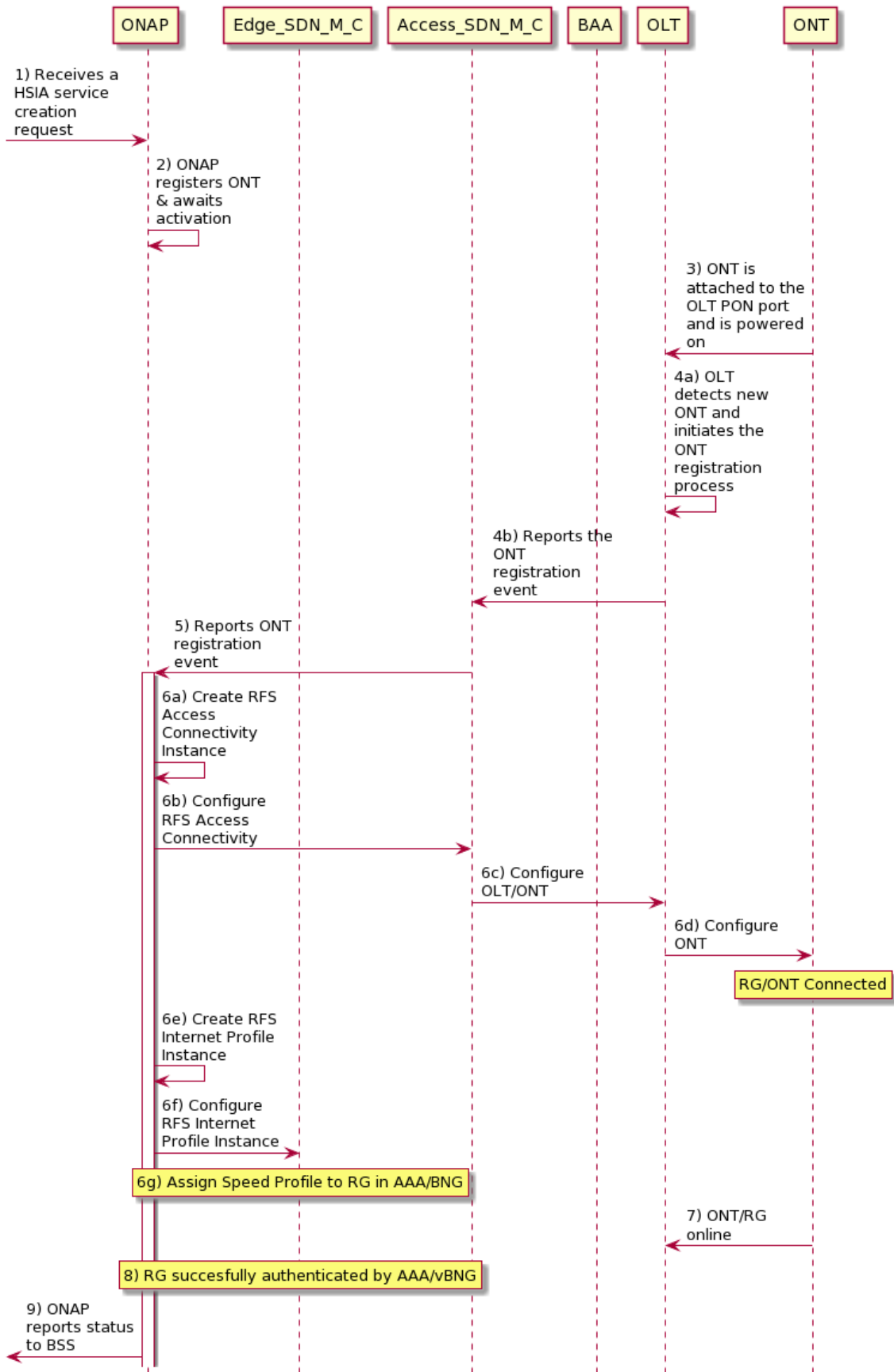

1. ONAP receives a CFS HSIA service instance creation request including the requesting entity's external ID for the new service instance, service type ID in ONAP catalog, HSIA and CPE attributes



2. ONAP registers the ONT and awaits activation.
3. ONT is attached to PON port on OLT and is powered on.
4. OLT detects a new ONT and initiates the ONT registration process.
5. Access SDN M&C reports the ONT registration event to ONAP using the PNF registration VES event message that includes additional fields, such as PON UNI (OLT attachment port) and Remote-ID.
6. ONAP continues with the provisioning of the CFS HSIA service by triggering the:
  - Creation of the RFS Access Connectivity, which will configure the ONT and the OLT via the Access SDN M&C
  - Creation/configuration of the RFS Internet Profile (e.g. customer's speed profile)
7. ONT becomes online and initiates the CFS HSIA activation procedure within the Edge SDN M&C using the information in the DHCP request.
8. The Edge SDN M&C authenticates the ONT and sends the Authentication event result to ONAP using the CPE Authentication VES event message.
9. ONAP reports the status of the CPE Authentication to the BSS portal.

## **Interaction 2: Zero-touch relocation of the ONT for ONAP Integration for Residential Broadband HSIA Service**

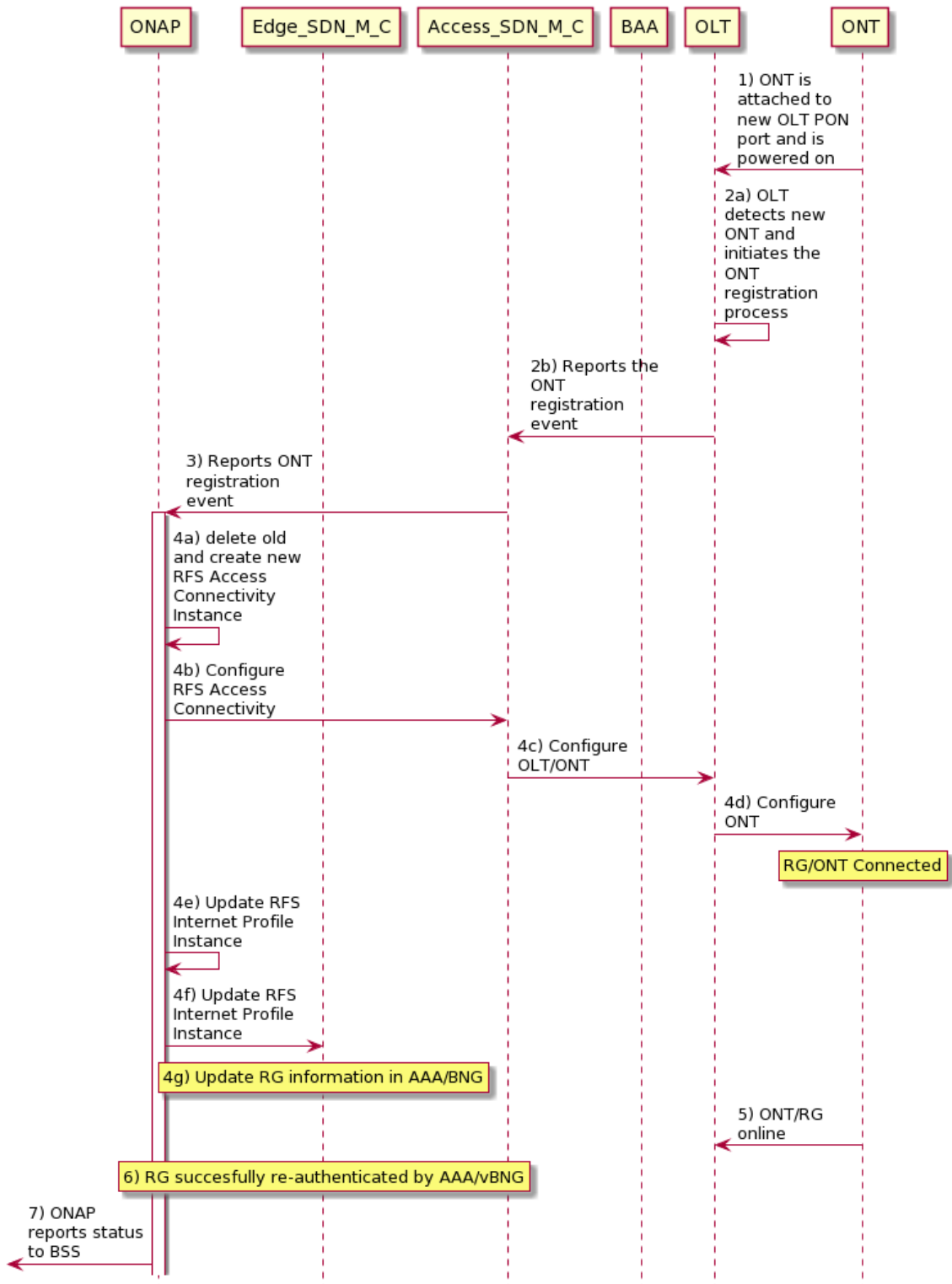

1. User moves the ONT to a PON port in OLT #1 to PON port on OLT #2.
2. OLT detects a new ONT and initiates the ONT registration process.
3. Access SDN M&C reports the ONT registration event to ONAP using the PNF registration VES event message that includes additional fields, such as PON UNI (OLT attachment port) and Remote-ID.
4. ONAP re-provisions the CFS HSIA service by triggering the:

- Deletion of old RFS Access Connectivity and Creation of new RFS Access Connectivity
  - Updating of the RFS Internet Profile (e.g different address)
5. ONT becomes online and initiates the CFS HSIA activation procedure within the Edge SDN M&C using the information in the DHCP request.
  6. The Edge SDN M&C authenticates the ONT and sends the Authentication event result to ONAP using the CPE Authentication VES event message.
  7. ONAP reports the status of the CPE Authentication to the BSS portal.

## Success Criteria

### Interaction 1: Create and Activate HSIA Service for ONAP Integration for Residential Broadband HSIA Service

1. The CFS HSIA order is successfully completed.
  - a. ONT receives a routable address that can reach the server that is acting as the "Internet".
  - b. ONT/RG is successfully authenticated.
2. The customer gets Internet access with the requested rate.

### Interaction 2: Zero-touch relocation of the ONT for ONAP Integration for Residential Broadband HSIA Service

1. The CFS HSIA is automatically reconfigured after user moves and plugs ONT in a new location. Reconfiguration includes:
  1. Deletion of the Access RFS connectivity in OLT #1.
  2. Creation of the Access RFS connectivity in OLT #2.
  3. Reassignment of the routeable address that can reach the server that is acting as the "Internet".
  4. Authentication of the ONT.
- The HSIA service is established for that user at the requested rate.