

APP NOTES

CloudCO-APPN-006 - Virtual Access Node (vAN)- based FANS service

Table of Contents

1	Summary/Objective	3
2	Assumptions and Preconditions	3
3	Description of the System	4
4	Components	8
5	Actors	8
6	Interactions	9
6.1	Interaction 1: Create a VNO Network	9
6.2	Interaction 2: Create a VNO L2 Service	9
6.3	Interaction 3: Pre-provisioning of a VNO's ONT	11
6.4	Interaction 4: Activate a VNO's ONT	12
6.5	Interaction 5: L2 Performance Monitoring on a VNO ONT	13
6.6	Interaction 6: Handling a Customer Migration	14
7	Success Criteria	15
8	Appendix	15

Editor(s): Bruno Cornaglia (Vodafone)

Contributor(s): Supporting Company/ies: Vodafone

1 Summary/Objective

This application note establishes a Fixed Access Network Sharing service provided by an Infrastructure Provider (InP) via a fixed access CloudCO Domain architecture.

Section 6.1.1.1 of TR-384 indicates that the support of multiple tenants occurs via the E2E Service Orchestrator (SO) interacting with the same CloudCO Domain Orchestrator (CCO DO). Though the E2E SO is outside the CCO scope, it is worthwhile for a multi-tenancy service like FANS to make hypothesis about how/what interactions take place between the E2E SO and the CCO DO via the (FANS) NB API.

The FANS service is provided to a set of Virtual Network Operators (VNOs) by allocating to each of them access network resources available in the CloudCO domain.

Main interactions among CloudCO entities for the creation and activation of the FANS service are provided herein.

2 Assumptions and Preconditions

The following bullets narrow down the AppNote scope and technical/deployment variables to allow an easier description of the foreseen solution.

They are not necessarily prescriptive and some of them may be extended to widen the applicability of the AppNote.

1. The InP CloudCO Domain instance is already fully bootstrapped
2. The InP CloudCO Domain consists of access network resources (for simplicity physical OLTs operating on a PON based FTTH architecture)
3. A single CloudCO Domain Orchestrator (CCO DO), handled by InP, overall controls the CloudCO facility
4. The CCO DO, exposes also its resources to the OSS layer of a Network Operation Tenant (i.e. one or more InP departments)
5. A single VNFM is deployed in the system and it is the solely responsible for instantiate the VNFs
6. The CCO DO exposes to the VNOs (Service Tenants) a NB API that fulfill the FANS framework as agreed between the InP and the Service Tenants. This is realized by giving to VNOs the ability to connect to the CloudCO Northbound APIs (Os-Ma-ccodo^T) per the following options:
 - a. segregated and secured VNO Management System (MS) instances provided by the InP and accessed via e.g. service-client applications
 - b. each VNO has its own flavor of MS in terms of FCAPS management and flow control
 - c. a mix of the above
7. Regardless of the source of the VNO MS, this element shall support the standard CloudCO Northbound APIs (Os-Ma-ccodo^T), and appropriate functionalities and attributes (resources and services) are exposed to VNOs through this standard interface
8. The CloudCO relies on the FANS interfaces described in WT-386 and here reported in the Appendix section

Note: There is a separation of interests, roles and responsibilities among CloudCO Infrastructure Provider (InP) and Tenant Service Providers (VNOs) that administratively and technically is reflected by the deployed M&C elements and the operational interfaces that connect them.

3 Description of the System

A VNO who accesses the E2E SO has its own configuration view because of its different service modes, compared to other tenants.

The VNO MS (residing inside the E2E SO) sends, via its standard FANS API (Os-Ma-ccodo^T), L2 service requests to the CCO DO that verifies:

- If the received L2 service request fulfills the profiles offered by the InP per the FANS framework
- The existing commercial agreements with that specific VNO and resource accessibility/availability

Then the CCO DO passes the request to the Access SDN Manager & Controller to create/configure the selected L2 resources on the target Access PNF and vANs (via the transcoding table within the InP Port Mapper).

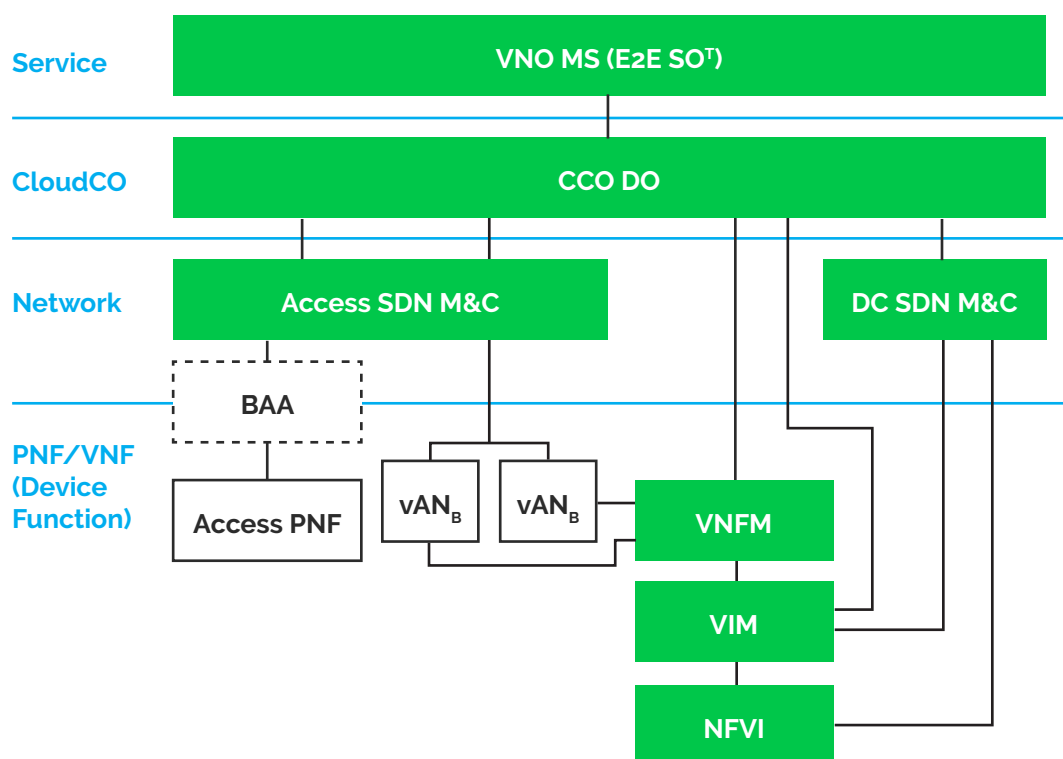

The Access SDN Manager & Controller verifies if the received request can be accomplished based on technological and traffic-engineering logics and if so it identifies the appropriate L1 profile to get to a full blown L1&L2 configuration. Then the Access SDN Manager & Controller sends the L1&L2 configuration to the Access PNF/VNF layer.

The L2-based service interface exposed to the VNOs, allows access to, at least, the attributes listed below.

Remark about the nature of the standard FANS API (Os-Ma-ccodoT per TR-384 nomenclature) exposed to VNOs

The parameters set below expresses a FANS service based on a pure L2 abstraction of the shared AN resources that enables VNOs to consume such parameters quite granularly.

Indeed the actual set of parameters exposed at the FANS API as well as their degree of abstraction of their representation on the VNO MS depends on the technical, commercial and/or regulatory agreements of each deployment environment.

For example, with regard to the set below, one may envision:

- a deeper and more granular access including also physical layer parameters (e.g. mapping or even configuring of T-CONT, handling of DBA parameters, relaying of ONT authentication information) which, along with a higher degree of management by the VNO, entails more complexity/responsibility in the configuration of the shared AN resource

OR, going towards the other direction

- an even more abstract exposure of L2 parameters belonging to a pre-defined set of service profiles that the InP, based on its knowledge and upon concertation with VNOs, configures and exposes via the FANS API; this offers to VNOs a lower degree of management but also less complexity in consuming their portion of AN resource.

Regardless of the degree of layer-depth and service-abstraction of the FANS API, the technical solution requires the support of separation of roles and of accessed resource-sets (**role-based** property), at least in Access SDN Manager & Controller. This is to allow a secure and segregated interaction to the VNOs and to grant instead a full management, control, orchestration and administration to the InP.

In detail, at the uplink port (V ref. point) of a target Access PNF, should at least expose:

- Configuration
 - # of VNO dedicated VLANs (likely in the form of S-VLANs in a Q-in-Q scheme)
 - S-VLAN Downlink/Uplink bandwidths (guaranteed/peak/...)
 - per S-VLAN priority
 - per S-VLAN Id (*may be assigned by the InP or arbitrarily chosen by the VNO*)
 - per S-VLAN L2 PM commands
 - per S-VLAN L2 alarm reporting commands
 - ...
- Parameters configurable per each S-VLAN:
 - # of C-VLANs
 - C-VLAN Downlink/Uplink bandwidths (guaranteed/peak/...)
 - per C-VLAN priority
 - per C-VLAN Id
 - per C-VLAN L2 PM commands
 - per C-VLAN L2 alarm reporting commands
 - ...

- Monitoring
 - Access PNF status
 - Monitoring of all the above parameters
 - per S-VLAN trunk status
 - per S-VLAN L2 PM counters
 - per S-VLAN L2 alarms
 - per C-VLAN L2 PM counters
 - per C-VLAN L2 alarms
 - ...

At the downlink port (U ref. point) of a target Access PNF, should at least expose:

- Configuration
 - # of VLANs
 - per-VLAN mapping to specific "VNO VLAN" on specific Access PNF uplink port
 - VLAN Downlink/Uplink bandwidths (guaranteed/peak/...)
 - per-VLAN priority
 - per-VLAN Id
 - per-VLAN L2 PM commands
 - per-VLAN L2 alarm reporting commands
 - ...
- Monitoring
 - ONT status
 - Monitoring of all the above parameters
 - per-VLAN trunk status
 - L2 PM counters
 - L2 alarms
 - ...

The Network Layer of the CloudCO Domain is composed by:

- Access SDN M&C – Provides SDN Management and Control (FCAPS and Flow Control management functionalities) of the Access PNF (through the BAA), vAN and other VNFs in the access segment within the CloudCO instance. It includes an InP Port Mapper to map logical ports to the host physical ports where the customer lines terminate

Please note that in this case the InP Port Mapper is not the virtual switch that provides network-level data routing and switching functionalities as defined in TR-370, but it establishes the relationship between physical ports of the Access PNF and the logical ports of a vAN

- DC, PNF and VNF SDN M&C Controllers, as well as the VIM to establish end to end user-plane connectivity

The CCO DO orchestrates the instantiation of the VNO's user plane through the Access PNF, vAN and the NFVI switch fabric.

Each vAN has visibility of those virtual ports assigned to it via the Access SDN Management & Control.

The following figure depicts the management and control of the Access PNF and the vANs.

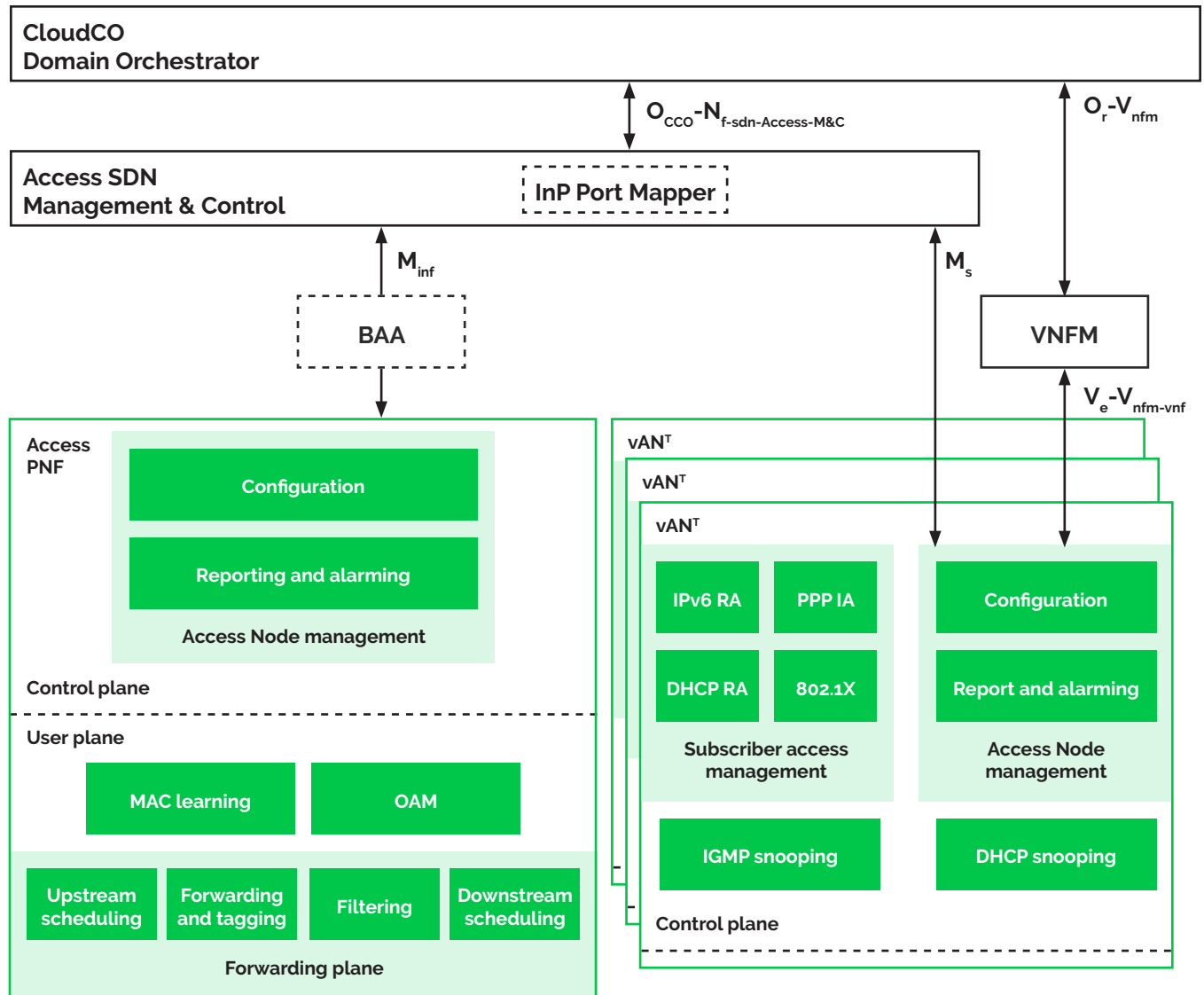

Please note that the role of the Broadband Access Abstraction (BAA) is only of mediation between access elements and management elements and thus it will not be represented in any interaction in this application note.

FANS is defined by two architectures in TR-370, however in a CloudCO implementation it is represented by a shared Access PNF (in terms of Forwarding Plane) and multiple vANs (having Control Plane functionalities) on the NFVI infrastructure.

4 Components

Component Framework Name	Component Description
CCO DO	TR-384, WT-411
ACCESS SDN M&C	Access SDN Management and Control: TR-384, WT-411, WT-413 – Provides SDN Management and Control (FCAPS and Flow Control management functionalities) of the Access PNF, vAN and other VNFs in the access segment within the CloudCO instance. It includes an InP Port Mapper to map logical ports over the Access PNF physical ports
DC SDN M&C	Data Center SDN Management and Control: WT-411 – Provides SDN Management and Control of the NFVI
VNFM	VNF Manager: WT-411, ETSI NFV – Controls the lifecycle management of VNF instances
VIM	Virtualized Infrastructure Manager: WT-411, ETSI NFV – Controls the NFVI, deploys VNFs and interconnects them
NFVI	NFV Infrastructure: WT-411, ETSI NFV – The physical network fabric
Access PNF	Physical Access Node (PNF)
vAN	Virtual Access Node (VNF)

5 Actors

Actor Name	Actor Description	Actions at CCO Perimeter (CCO DO NBI, User action)
CloudCO Infrastructure Provider (InP)	Creates and Handles VNOs Networks	<ol style="list-style-type: none"> 1. Creation of VNO Networks 2. Creation of VNO L2 Service 3. Handling of VNOs' Customers Migrations
Tenant Service Providers (VNOs)	Provides commercial services to its customers	<ol style="list-style-type: none"> 1. Creation of services for the customers within their virtual access networks, using their own service models

6 Interactions

6.1 Interaction 1: Create a VNO Network

1. The CCO DO receives a "**VNO Network Creation**" request from the VNO MS (in the E2E SO) via the Os-Ma-ccodo^T interface
2. CCO DO requests the VNFM to instantiate a new VNF (vAN) instance into the NFVI, as required for the tenant's services via the Or-Vnfm and Ve-vnfm-vnf interfaces
 - a. The VNFM sends a negative notification up to the VNO MS if the configuration cannot be fulfilled
3. The CCO DO exposes to the VNO MS a network map of Access PNFs, consistently with the VNO requested list and a L2-based service interface to configure and manage the vAN logical resources

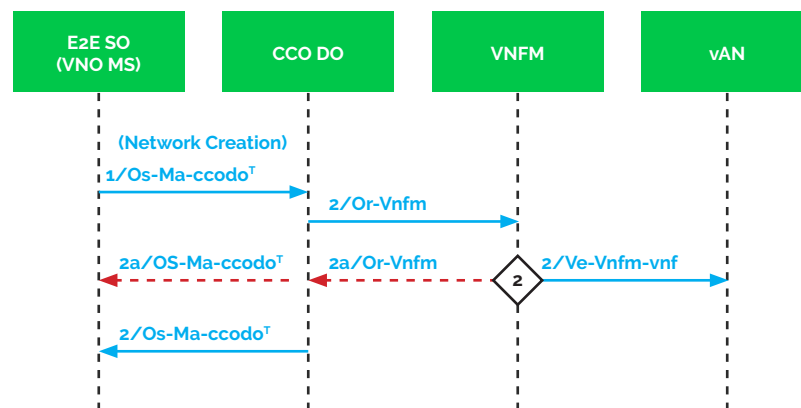

6.2 Interaction 2: Create a VNO L2 Service

1. The CCO DO receives a "**VNO L2 Service**" request from the VNO MS (in the E2E SO) via the Os-Ma-ccodo^T interface
2. The CCO DO verifies that the request fulfills the profiles offered by the InP per the FANS framework, the existing commercial agreements with that specific VNO and resource accessibility/availability
 - a. The CCO DO sends a negative notification to the VNO MS if the L2 Service request cannot be fulfilled
3. CCO DO request the Access SDN M&C to allocate an unused VLAN on the Access PNF uplink via the Occo-Nf-sdn-Access-M&C and Minf interfaces
 - a. The Access SDN M&C sends a negative notification up to the VNO MS if the allocation cannot be fulfilled
4. CCO DO requests the DC SDN M&C to configure the above-mentioned VLAN on the switch attached to the Access PNF on all of its ports via the Occo-Nf-sdn-dc and Mfc-sdn-dc-Nf interfaces
 - a. The DC SDN M&C sends a negative notification up to the VNO MS if the configuration cannot be fulfilled
5. CCO DO requests the VIM to set up a new virtual network inside the NFVI for the access-side connections via the Or-Vi and Nf-Vi interfaces
6. CCO DO requests the VIM to set up a L2 bridge between the above-mentioned uplink VLAN and the virtual network on the compute hosts attached to the switches that attaches to the Access PNF via the Or-Vi and Nf-Vi interfaces

7. CCO DO requests the Access SDN M&C to connect the LAN facing interface of the vAN instance to the aforementioned virtual network the Occo-Nf-sdn-Access-M&C and Ms interfaces
8. CCO DO requests the VIM to set up another new virtual network inside the NFVI for the WAN-side connections via the Or-Vi and Nf-Vi interfaces
9. CCO DO requests the VIM to connect this virtual network to the WAN facing interface of the VNF (vAN) instance via the Or-Vi and Nf-Vi interfaces
10. CCO DO reports to the VNO (E2E SOT) that the L2 Service Creation is completed successfully and handles abstract access for the VNO via the Os-Ma-ccodoT interface

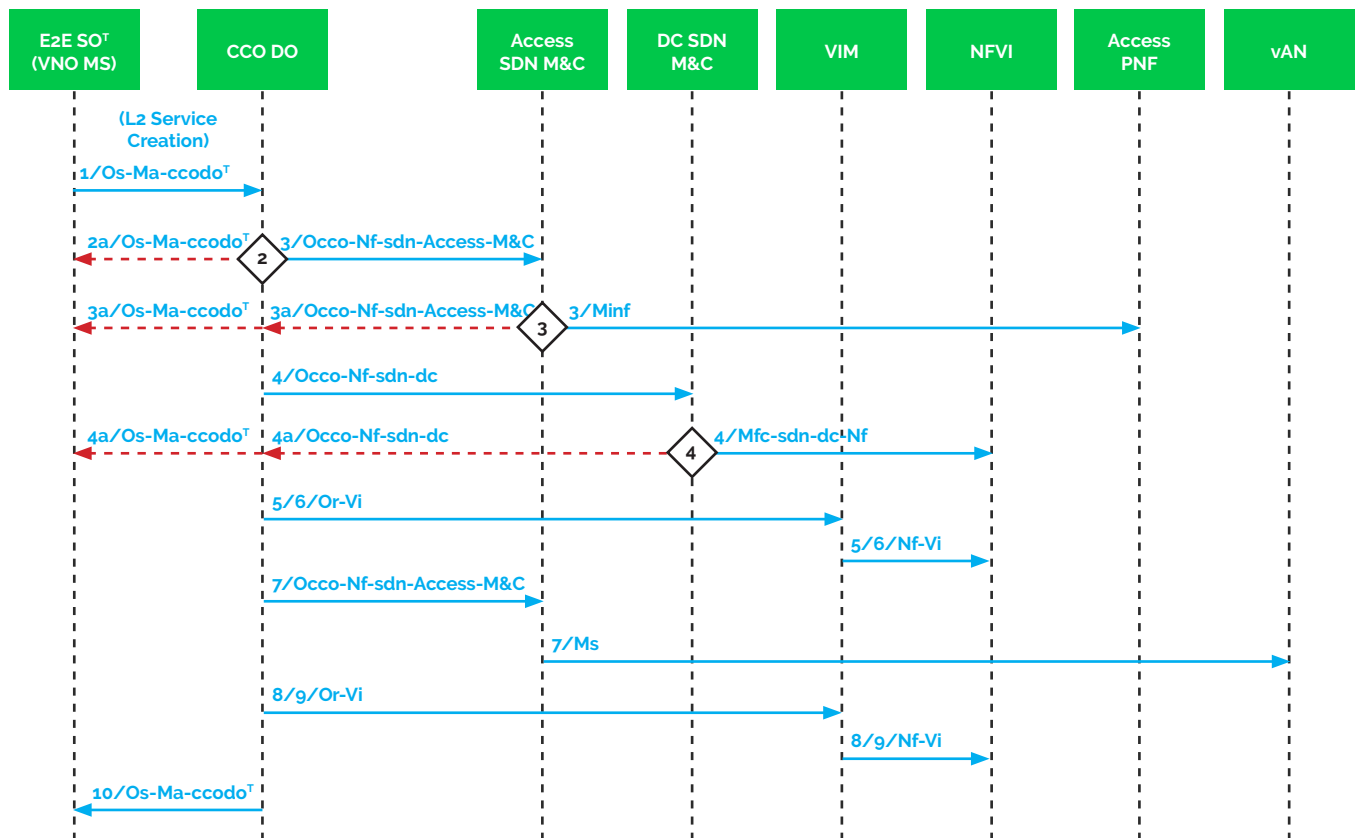

6.3 Interaction 3: Pre-provisioning of a VNO's ONT

1. The CCO DO receives an "**ONT Provisioning**" request from the VNO MS (in the E2E SO) via the Os-Ma-ccodo^T interface
2. The CCO DO verifies that the request fulfills the profiles offered by the InP per the FANS framework, the existing commercial agreements with that specific VNO and resource accessibility/availability
 - a. The CCO DO sends a negative notification to the VNO MS if the request cannot be fulfilled
3. CCO DO requests the Access SDN M&C to configure the selected profile (i.e., Logical ID, Vendor ID, S/N, etc.) for the target ONT in the Access PNF
 - a. The CCO DO sends a negative notification to the VNO MS if the request cannot be fulfilled
4. CCO DO reports to the VNO (E2E SOT) that the ONT Pre-provisioning is completed successfully and handles abstract access for the VNO via the Os-Ma-ccodo^T interface

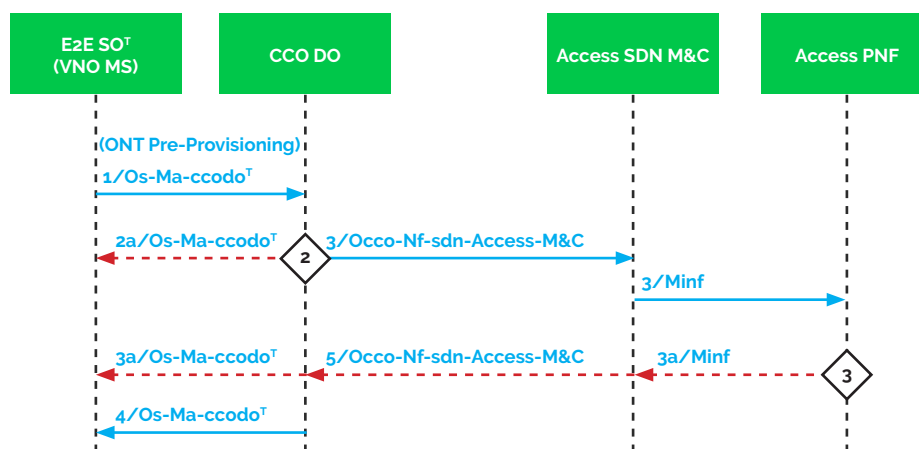

6.4 Interaction 4: Activate a VNO's ONT

As a prerequisite, the ONT (which is provided/installed by the InP) at the PON termination point in the VNO's customer premise, is switched on and a L1 communication link between to the OLT and the ONT is established via ONT authentication mechanism.

1. The CCO DO receives an **"ONT Activation"** request from the VNO MS (in the E2E SO) via the $Os-Ma-ccodo^T$ interface
2. The CCO DO verifies that the request fulfills the profiles offered by the InP per the FANS framework, the existing commercial agreements with that specific VNO and resource accessibility/availability
3. CCO DO request the Access SDN M&C, in collaboration with the Access PNF, to configure the target ONT with the L2 service requested by the VNO
 - a. The CCO DO sends a negative notification to the VNO MS if the request cannot be fulfilled
4. CCO DO reports to the VNO (E2E SOT) that the ONT Activation is completed successfully and handles abstract access for the VNO via the $Os-Ma-ccodo^T$ interface

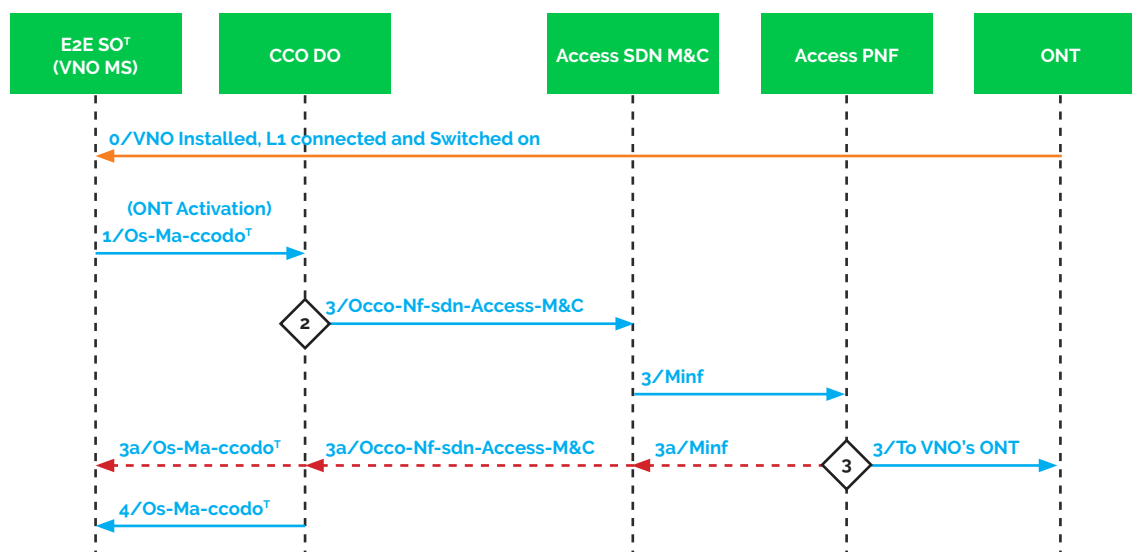

6.5 Interaction 5: L2 Performance Monitoring on a VNO ONT

As a prerequisite, all the above interaction are completed successfully.

1. The CCO DO receives a "**ONT L2 Performance Monitoring**" request from the VNO MS (in the E2E SO) via the Os-Ma-ccodo^T interface
2. CCO DO request the Access SDN M&C, in collaboration with the Access PNF, to collect Performance Monitoring (PM) measures from the target ONT
3. The ONT sends to the Access PNF the measured PM counters at the configured collection frequency
4. The Access PNF sends the PM counters to the Access SDN M&C which stores them
5. The Access SDN M&C sends the collected PM counters the CCO DO
6. The CCO DO handles abstract access to the PM counters for the VNO (E2E SO^T) via the Os-Ma-ccodo^T interface

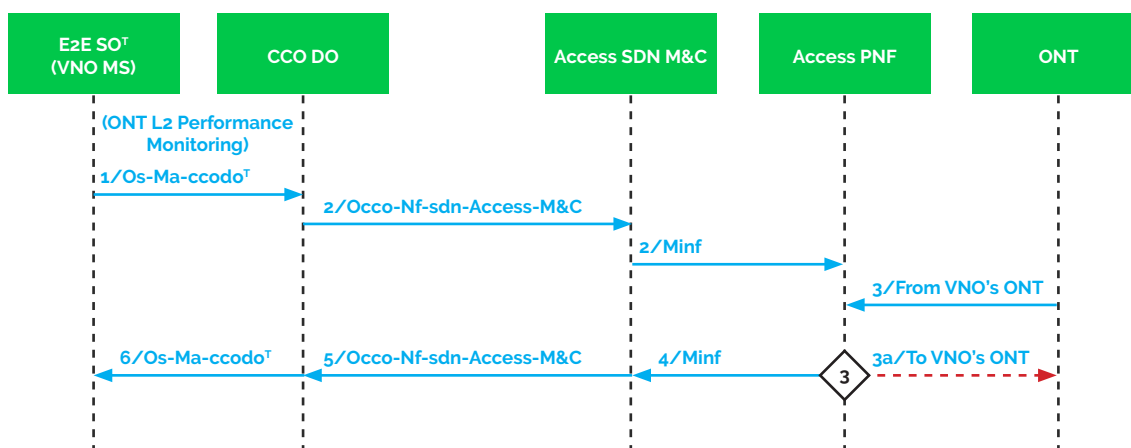

6.6 Interaction 6: Handling a Customer Migration

A VNOA's customer wants to migrate its services to VNO_B. Since both VNOs terminating on the same Access PNF, there is no need for manual intervention on the Access PNF because the physical port which the customer is connected to remains the same after the migration.

1. The CCO DO receives a "**Customer Migration**" request from both the VNO_A MS and the VNO_B MS (in the E2E SO) via the Os-Ma-ccodo^T interface. The "Customer Migration" request is in the form of a "Customer-J release" from VNO_A MS and "Customer-J activation and ONT L2 Service Creation" from VNO_B MS. Note: the above interaction_A is illustrative, not prescriptive, of the way the involved actors may interact to communicate the migration of a customer from one VNO to another. In this case it is assumed that administratively the "migration procedure" requires that the both involved VNOs issue a command about the same customer (release vs activation). Furthermore it is assumed that the customer activation [administrative command] is issued together with the ONT configuration [operational command] that allows to re-provision the customer over the new connectivity to avoid/minimize service downtime.
2. The CCO DO verifies that the request fulfills the profiles offered by the InP per the FANS framework, the existing commercial agreements with that specific VNO and resource accessibility/availability
 - a. The CCO DO sends a negative notification to VNO_A MS and the VNO_B MS if the Migration request cannot be fulfilled
3. CCO DO initialize the migration process by request the Access SDN M&C to change the mapping between the physical port and the old/new logical ports used in the migration in the internal InP Port Mapper. In details, this operation is executed by:
 - Removing the "Customer-J termination" from VNO_A's manageable resources and sending to VNOA MS a positive notification of the customer release command
 - Adding "Customer-J termination" to VNO_B's manageable resources and sending to VNO_B MS a positive notification of the customer activation command At this point the customer is released from VNO_A and it should be activated by the VNO_B. The operational part of VNO_B's command takes place with the same steps 3 to 9 of "Interaction 2: Create a VNO L2 Service", with the "Interaction 3: Pre-provisioning of a VNO's ONT" and then with the "Interaction 4: Activate a VNO's ONT" for configuring the new service profiles at the ONT level.
4. CCO DO reports to both the VNOs that the Customer Migration is completed successfully via the Os-Ma-ccodo^T interface

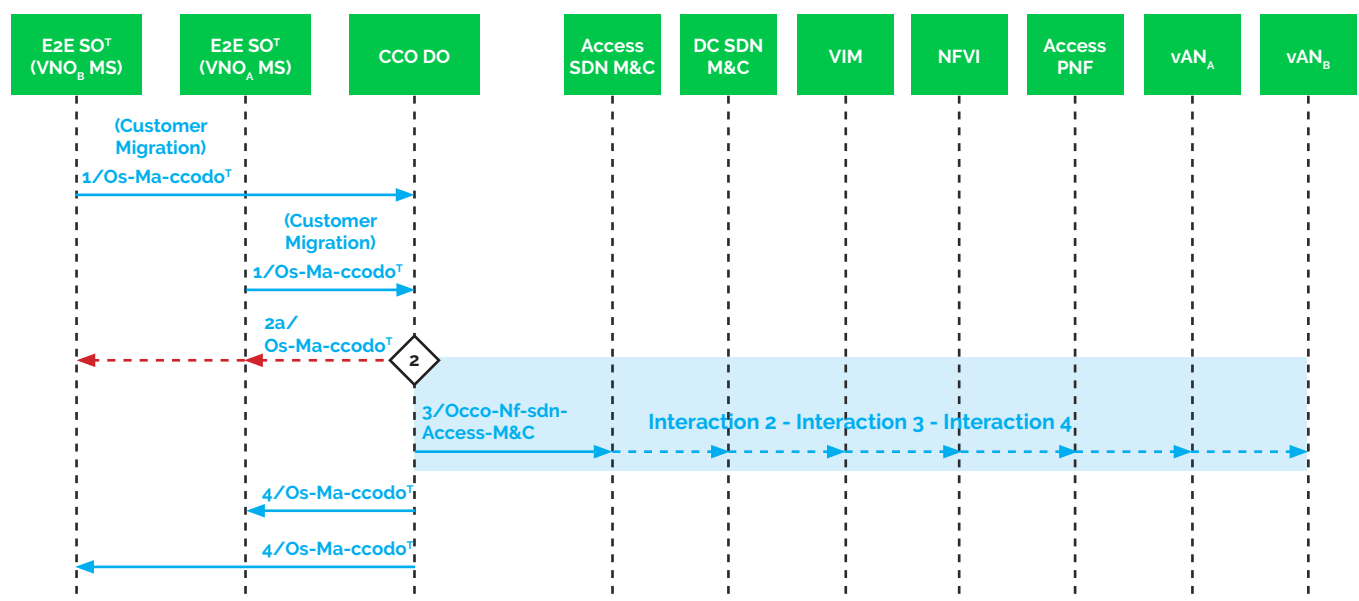

7 Success Criteria

Interaction 1:

1. VNOs can access to its network map per the list agreed with the InP

Interaction 2:

1. L2 resources of the target Access PNF are configured and allocated per VNO request
2. InP's full network view and VNO's scoped network view are updated per the above configuration

Interaction 3:

1. L2 resources of the target ONT are configured and allocated per VNO request
2. InP's full network view and VNO's scoped network view are updated per the above configuration

Interaction 4:

1. L1 and L2 connectivity is established between the ONT and the Access PNF's uplink interface
2. VNO is able to deliver the service to the end customer

Interaction 5:

1. L2 PM collection is carried out as configured
2. Collected L2 PM counters are reported and stored in the Access Manager & Controller
3. Collected L2 PM counters are made available to the VNO MS

Interaction 6:

1. The customer migration is completed successfully and the customer can access to connectivity and services through VNOB network

8 Appendix

The following table provides an indicative correspondence of the FANS interfaces described in WT-386 and ETSI NFV standard documents and those defined in the CloudCO generic framework (TR-384).

FANS WT-386 Name	CloudCO TR-384
M_{inf}	M_{inf} via $O_s-M_{a-ccodo}$
O_s-M_{a-nfvo}	$O_s-M_{a-ccodo}$
V_e-V_{nfm}	$V_e-V_{nfm-vnf} / V_e-V_{nfm-em}$
N_t-V_i	N_t-V_i

The description of the interfaces used in this application note will be documented in WT-411 and WT-413.

If you are interested in joining the Broadband Forum and shaping the future of broadband through this initiative and a wide variety of other activities, contact our Membership Development Manager at info@broadband-forum.org or visit us at our [membership page](#).