Atmel AVR310: Using the USI Module as a I²C Master

Atmel AVR 8-bit Microcontroller**Introduction**

The Two-wire serial Interface (TWI) is compatible with Philips' I²C protocol. The bus was developed to allow simple, robust and cost effective communication between integrated circuits in electronics. The strengths of the TWI bus includes the capability of addressing up to 128 devices on the same bus, arbitration, and the possibility to have multiple masters on the bus.

The Universal Serial Interface (USI) module on devices like Atmel ATmega169, ATtiny26, and ATtiny2313 has a dedicated Two-wire mode. The USI provides the basic hardware resources needed for synchronous serial communication. Combined with a minimum of control software, the USI allows higher transfer rates and uses less code space than solutions based on software only.

This application note describes a TWI master implementation, in form of a full-featured driver and an example of usage for this driver. The driver handles transmission according to both Standard mode (<100kbps) and Fast mode (<400kbps).

Features

- C-code driver for TWI master
- Compatible with Philips' I²C protocol
- Uses the USI module
- Uses no interrupts or timers
- Supports both Standard mode and Fast mode

Table of Contents

| | |
|--|---|
| 1. Theory | 3 |
| 1.1 Two-wire Serial Interface | 3 |
| 1.2 Universal Serial Interface – USI | 4 |
| 2. Implementation | 6 |
| 2.2 Code Size | 8 |
| 3. Revision History | 9 |

1. Theory

This chapter gives a short description of the TWI interface and the USI module. For more detailed information refer to the datasheets.

1.1 Two-wire Serial Interface

The Two-wire Serial Interface (TWI) is ideally suited for typical microcontroller applications. The TWI protocol allows the systems designer to interconnect up to 128 individually addressable devices using only two bi-directional bus lines, one for clock (SCL) and one for data (SDA). The only external hardware needed to implement the bus is a single pull-up resistor for each of the TWI bus lines. All devices connected to the bus have individual addresses, and mechanisms for resolving bus contention are inherent in the TWI protocol.

Figure 1-1. TWI Bus Interconnection

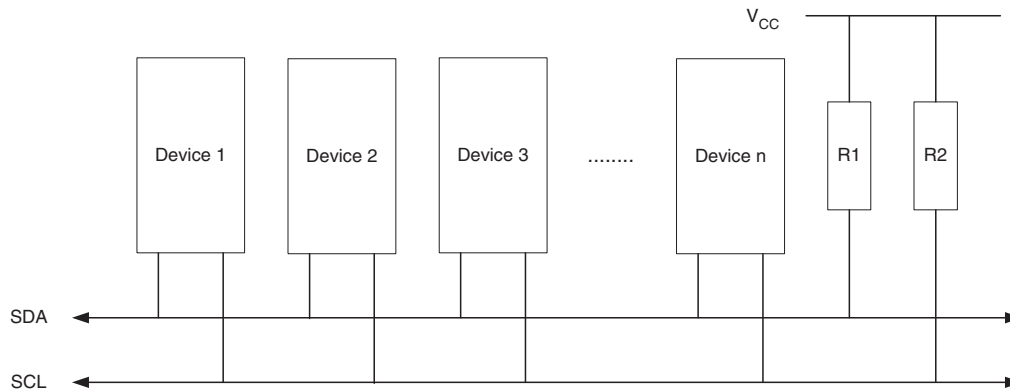

The TWI bus is a multi-master bus where one or more devices, capable of taking control of the bus, can be connected. Only Master devices can drive both the SCL and SDA lines while a Slave device is only allowed to issue data on the SDA line.

Data transfer is always initiated by a Bus Master device. A high to low transition on the SDA line while SCL is high is defined to be a START condition (or a repeated start condition).

Figure 1-2. TWI Address and Data Packet Format

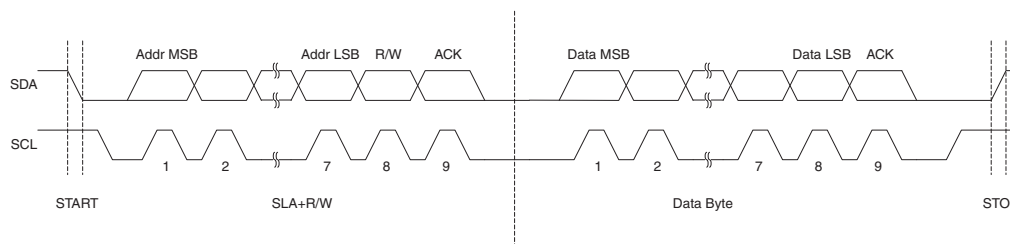

A START condition is always followed by the (unique) 7-bit slave address and then by a Data Direction bit. The Slave device addressed now acknowledges to the Master by holding SDA low for one clock cycle. If the Master does not receive any acknowledge the transfer is terminated. Depending of the Data Direction bit, the Master or Slave now transmits 8-bit of data on the SDA line. The receiving device then acknowledges the data. Multiple bytes can be transferred in one direction before a repeated START or a STOP condition is issued by the Master. The transfer is terminated when the Master issues a STOP condition. A STOP condition is defined by a low to high transition on the SDA line while the SCL is high.

If a Slave device cannot handle incoming data until it has performed some other function, it can hold SCL low to force the Master into a wait-state.

All data packets transmitted on the TWI bus are nine bits long, consisting of one data byte and an acknowledge bit. During a data transfer, the master generates the clock and the START and STOP conditions, while the receiver is responsible for acknowledging the reception. An Acknowledge (ACK) is signaled by the receiver pulling the SDA line low during the ninth SCL cycle. If the receiver leaves the SDA line high, a NACK is signaled.

1.2 Universal Serial Interface – USI

The Universal Serial Interface (USI) provides the basic hardware resources needed for synchronous serial communication. Combined with a minimum of control software, the USI allows higher transfer rates and uses less code space than solutions based on software only. Interrupts are included to minimize the processor load. The main features of the USI are:

- Two-wire Synchronous Data Transfer
- Three-wire Synchronous Data Transfer
- Data Received Interrupt
- Wakeup from Idle Mode
- In Two-wire Mode: Wake-up from All Sleep Modes, Including Power-down Mode
- Two-wire Start Condition Detector with Interrupt Capability

The USI Two-wire mode is compliant to the TWI bus protocol, but without slew rate limiting on outputs and input noise filtering.

Figure 1-3. Universal Serial Interface, Block Diagram

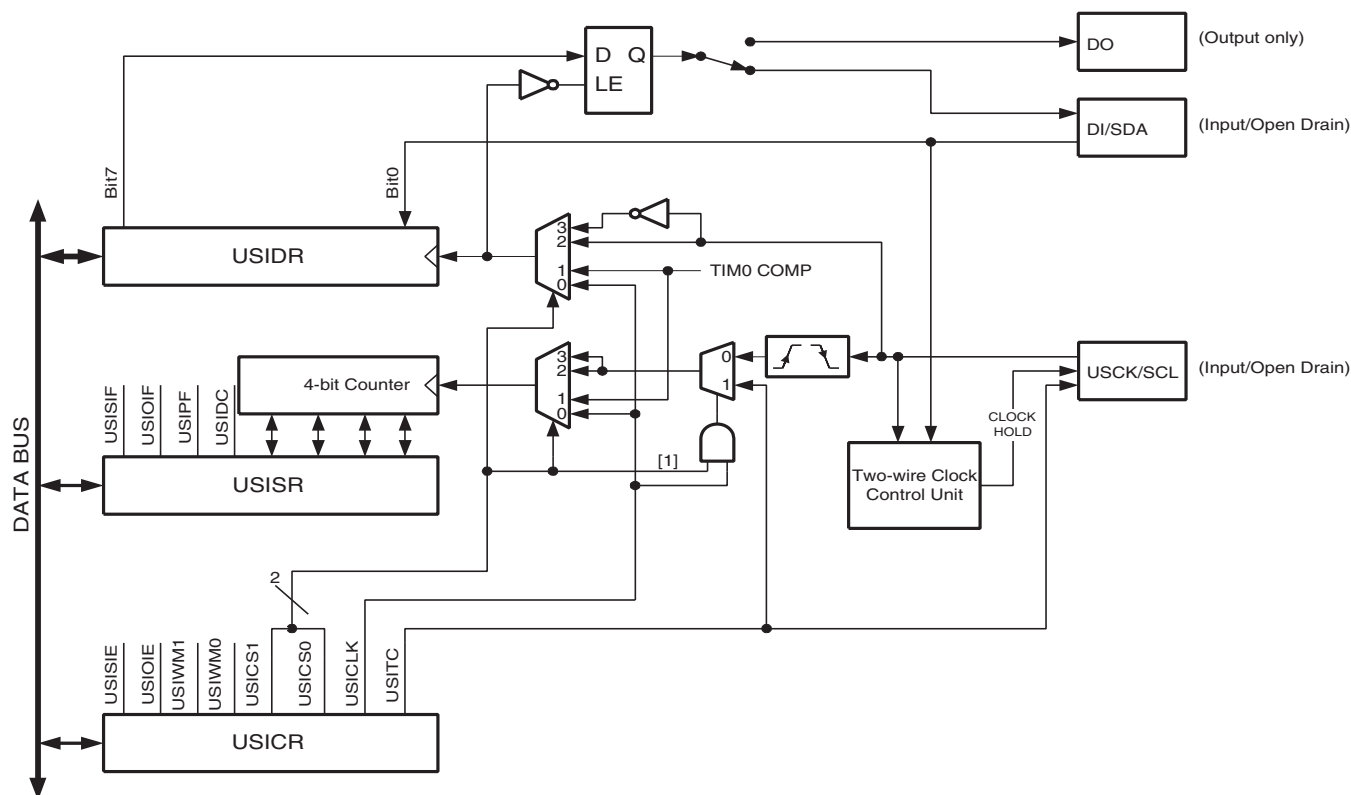
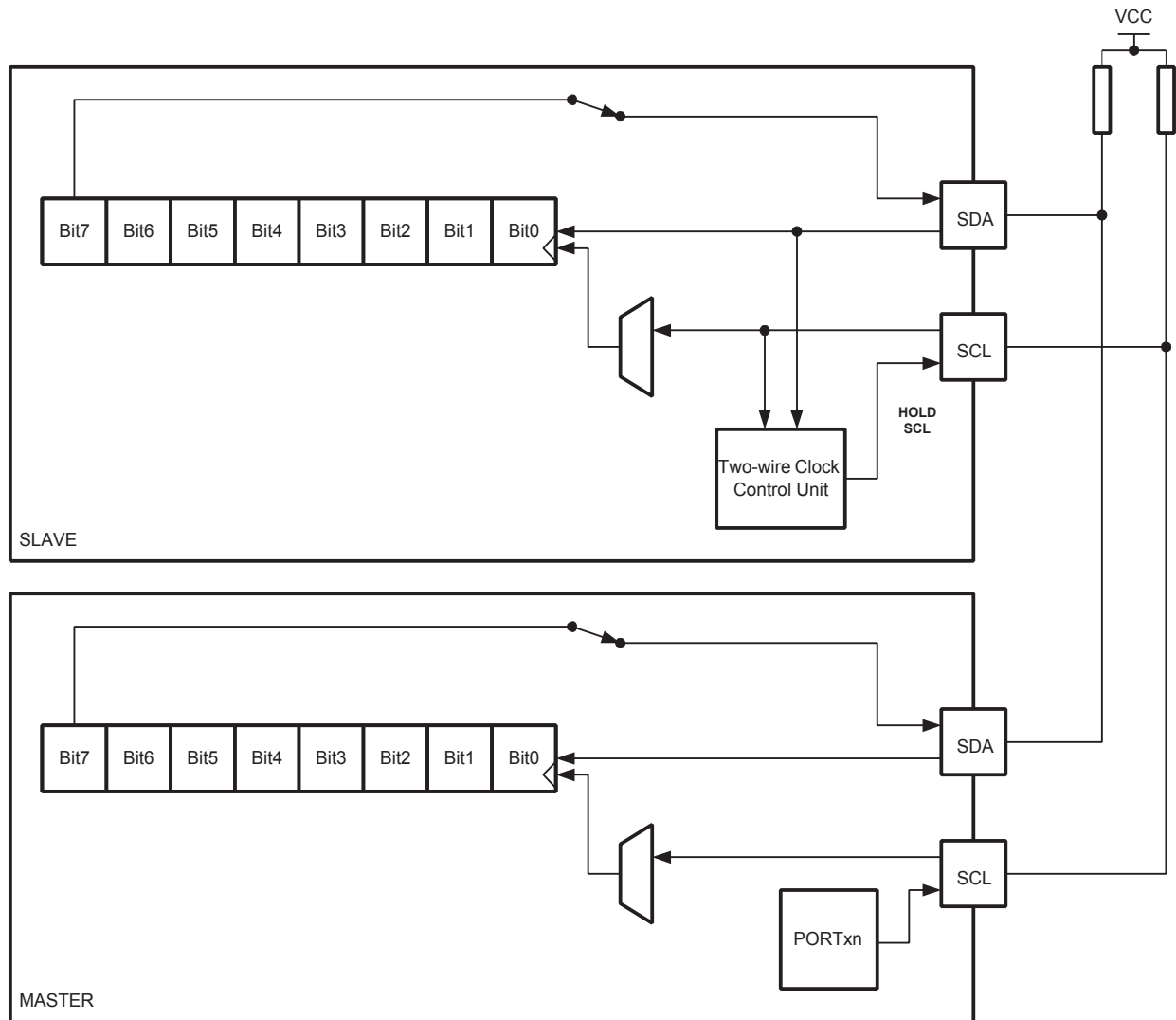

Figure 1-4. Two-wire Mode Operation, Simplified Diagram



The USI Data Register (USIDR) is an 8-bit Shift Register that contains the incoming and outgoing data. The register has no buffering so the data must be read as quickly as possible to ensure that no data is lost.

The USI Status Register (USISR) contains a 4-bit counter. Both the Serial Register and the counter are clocked simultaneously by the same clock source. This allows the counter to count the number of bits received or transmitted and sets a flag alternatively generates an interrupt when the transfer is complete. The clock can be selected to use three different sources: The SCL pin, Timer/Counter0 Compare Match or from software. The Two-wire clock control unit generates flags when a start condition, data collision, or stop condition is detected on the Two-wire bus.

2. Implementation

The application note describes the implementation of a TWI master. The driver is written as a standalone driver that easily can be included into the main application. Use the code as an example, or customize it for own use. Defines and status registers are all set in the application note header file.

The driver uses the USI module and standard IO pin control. No additional resources as timers or any other interrupt sources are needed. The driver ensures correct timing even if it gets any interrupt signals during execution. The execution is however sequential, i.e. all cpu resources are therefore used during transmission.

Figure 2-1. Flowchart of the transceiver function. A flowchart of the sub function USI_TWI_Master_Transfer is found in Figure 2-2

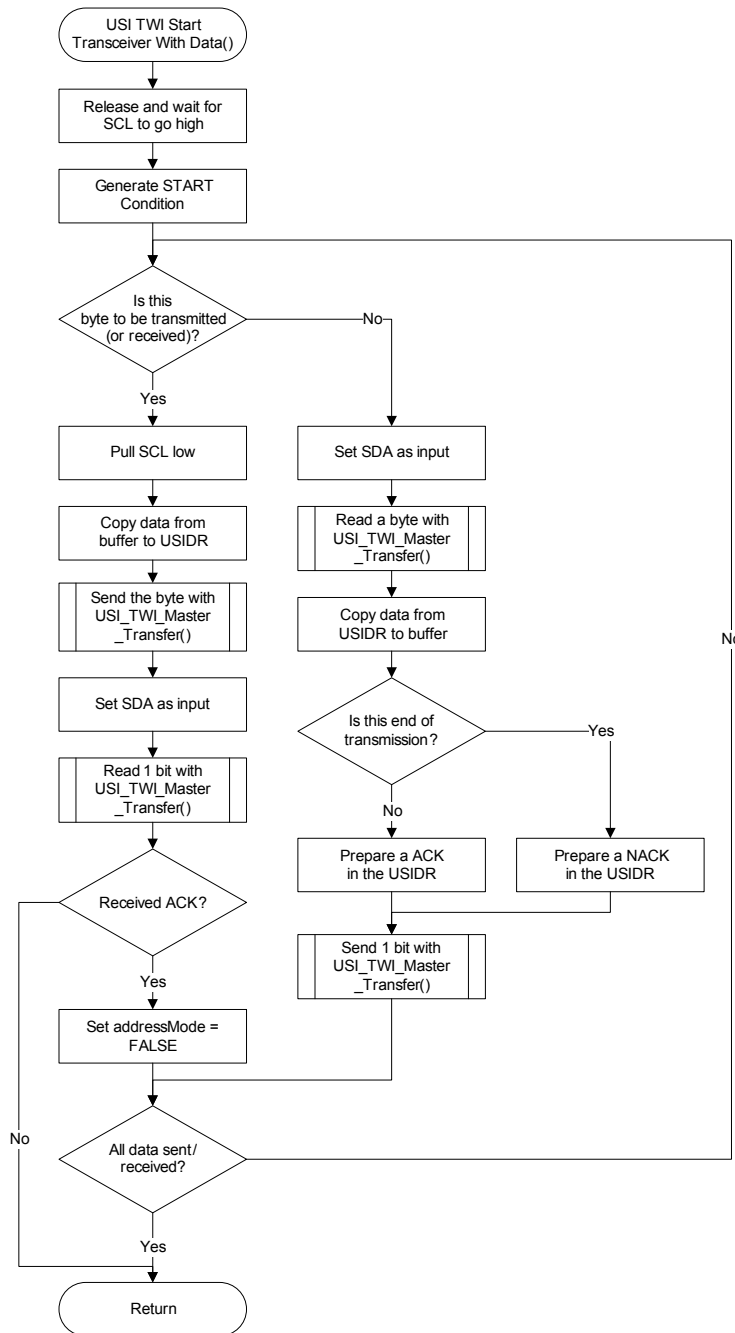

The driver consists of these functions:

- USI_TWI_Master_Initialise
- USI_TWI_Start_Transceiver_With_Data
- USI_TWI_Master_Transfer
- USI_TWI_Master_Stop
- USI_TWI_Get_State_Info

The *USI_TWI_Master_Initialise* function is used to set the USI module in TWI mode, and setting the TWI bus in idle/released mode.

The START and RESTART conditions are included into the transceiver function;

USI_TWI_Start_Transceiver_With_Data. A flowchart of the function can be found in [Figure 2-1](#). The same function is used for both transmit and receive operations. The transceiver takes a pointer to a transmission buffer as parameter, together with the number of bytes in the buffer. The first location in the buffer must always contain both the address of the slave and the read/write bit determining the transmission type. If the master is requesting data from the slave, the transmit buffer only contains the slave address (with the read bit set), and a data size parameter indicating the number of bytes requested. The transceiver function will put the received data into the transmission buffer.

USI_TWI_Master_Transfer ([Figure 2-2](#)) is called from within *USI_TWI_Start_Transceiver_With_Data*.

USI_TWI_Master_Stop is called from within *USI_TWI_Start_Transceiver_With_Data*.

Figure 2-2. Flowchart of the general transfer function. The function is used by the *USI_TWI_Start_Transceiver_With_Data* function in [Figure 2-1](#)

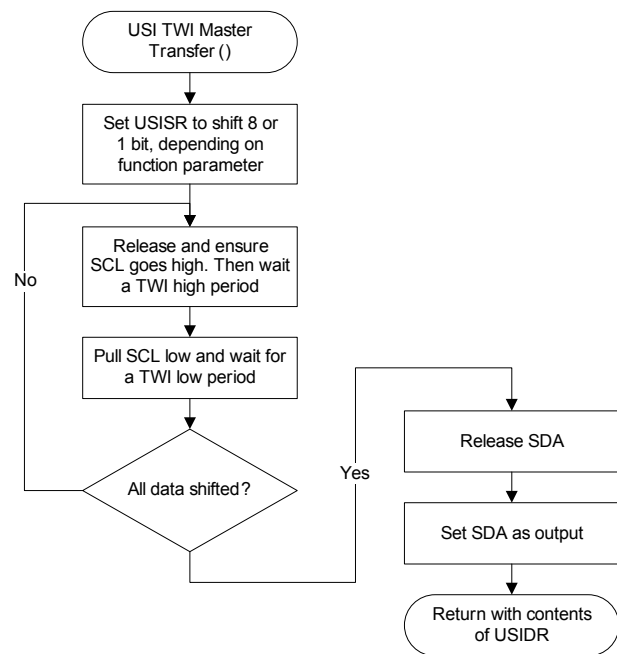

On completion the transceiver function holds the TWI bus by pulling the SCL line low. A new transmission can be initiated immediately by rerunning the transceiver function.

The transceiver function generates error codes if the transmission fails. The codes are listed in the header file and in [Table 2-1](#). Use the function *USI_TWI_Get_State_Info* to get hold of the error state if the transceiver returns a fail.

Table 2-1. Error codes returned from the transceiver function

| Define name of error code | # | Description |
|---------------------------|------|---|
| USI_TWI_NO_DATA | 0x00 | Transmission buffer is empty |
| USI_TWI_DATA_OUT_OF_BOUND | 0x01 | Transmission buffer is outside SRAM space |
| USI_TWI_UE_START_CON | 0x02 | Unexpected Start Condition |
| USI_TWI_UE_STOP_CON | 0x03 | Unexpected Stop Condition |
| USI_TWI_UE_DATA_COL | 0x04 | Unexpected Data Collision (arbitration) |
| USI_TWI_NO_ACK_ON_DATA | 0x05 | The slave did not acknowledge all data |
| USI_TWI_NO_ACK_ON_ADDRESS | 0x06 | The slave did not acknowledge the address |
| USI_TWI_MISSING_START_CON | 0x07 | Generated Start Condition not detected on bus |
| USI_TWI_MISSING_STOP_CON | 0x08 | Generated Stop Condition not detected on bus |

The driver takes care of the low level communication as transmission/reception of address, data, and ACK/NACK. High level operations like address setting, message interpreting, and data preparation, must be taken care of by the main application. A small sample code of how to use the driver is included.

This implementation does not support TWI bus arbitration. The device using this driver must therefore be the only master on the bus. As according to the TWI standard, all 127 slaves can be addressed individually on the bus. The lack of bus arbitration is not a limit of the USI module, and can be implemented into the driver, but is not in the scope for this application note.

The driver does not use interrupts and uses loops to control the TWI bus activity. To add additional execution control and security one can use a Watchdog Timer. This can prevent unintentional behavior on the TWI bus from blocking the application. All AVR® have an on-chip Watchdog Timer. For more information on the watchdog timer, check out the application note “[AVR132: Using the Enhanced Watchdog Timer](#)” and the datasheets.

The driver has code for both standard and fast mode TWI timing. Set selected mode in the header file of the driver. The default setting is fast mode.

2.2 Code Size

Table 2-2. Code Sizes with IAR EWAVR 3.10 with all Code Optimization On

| Function | Size [bytes] |
|--|--------------|
| USI_TWI_Master_Initialise() | 28 |
| USI_TWI_Start_Transceiver_With_Data() | 142 |
| USI_TWI_Master_Transfer() | 56 |
| USI_TWI_Master_Stop() | 24 |
| USI_TWI_Get_State_Info() | 6 |
| | 256 |

3. Revision History

| Doc. Rev. | Date | Comments |
|-----------|---------|--------------------------|
| 2561C | 12/2013 | New template |
| 2561B | 09/2004 | Updated |
| 2561A | Unknown | Initial document release |

**Atmel Corporation**

1600 Technology Drive
San Jose, CA 95110
USA

Tel: (+1)(408) 441-0311

Fax: (+1)(408) 487-2600

www.atmel.com

Atmel Asia Limited

Unit 01-5 & 16, 19F
BEA Tower, Millennium City 5
418 Kwun Tong Road
Kwun Tong, Kowloon
HONG KONG

Tel: (+852) 2245-6100

Fax: (+852) 2722-1369

Atmel Munich GmbH

Business Campus
Parking 4
D-85748 Garching b. Munich
GERMANY

Tel: (+49) 89-31970-0

Fax: (+49) 89-3194621

Atmel Japan G.K.

16F Shin-Osaki Kangyo Building
1-6-4 Osaki, Shinagawa-ku
Tokyo 141-0032
JAPAN

Tel: (+81)(3) 6417-0300

Fax: (+81)(3) 6417-0370

© 2013 Atmel Corporation. All rights reserved. / Rev.: 2561C-AVR-12/2013

Atmel®, Atmel logo and combinations thereof, Enabling Unlimited Possibilities®, AVR®, and others are registered trademarks or trademarks of Atmel Corporation or its subsidiaries. Other terms and product names may be trademarks of others.

Disclaimer: The information in this document is provided in connection with Atmel products. No license, express or implied, by estoppel or otherwise, to any intellectual property right is granted by this document or in connection with the sale of Atmel products. EXCEPT AS SET FORTH IN THE ATMEL TERMS AND CONDITIONS OF SALES LOCATED ON THE ATMEL WEBSITE, ATMEL ASSUMES NO LIABILITY WHATSOEVER AND DISCLAIMS ANY EXPRESS, IMPLIED OR STATUTORY WARRANTY RELATING TO ITS PRODUCTS INCLUDING, BUT NOT LIMITED TO, THE IMPLIED WARRANTY OF MERCHANTABILITY, FITNESS FOR A PARTICULAR PURPOSE, OR NON-INFRINGEMENT. IN NO EVENT SHALL ATMEL BE LIABLE FOR ANY DIRECT, INDIRECT, CONSEQUENTIAL, PUNITIVE, SPECIAL OR INCIDENTAL DAMAGES (INCLUDING, WITHOUT LIMITATION, DAMAGES FOR LOSS AND PROFITS, BUSINESS INTERRUPTION, OR LOSS OF INFORMATION) ARISING OUT OF THE USE OR INABILITY TO USE THIS DOCUMENT, EVEN IF ATMEL HAS BEEN ADVISED OF THE POSSIBILITY OF SUCH DAMAGES. Atmel makes no representations or warranties with respect to the accuracy or completeness of the contents of this document and reserves the right to make changes to specifications and products descriptions at any time without notice. Atmel does not make any commitment to update the information contained herein. Unless specifically provided otherwise, Atmel products are not suitable for, and shall not be used in, automotive applications. Atmel products are not intended, authorized, or warranted for use as components in applications intended to support or sustain life.