

Lighting *Mona Lisa* with LEDs: details concerning innovating techniques (TOSHIBA Lamp – 2013)

Marc Fontoynt, Jean Pierre Miras, Marco Angelini, Jean Chanussot, Christophe Marty, Grégory Duchêne, Leonid Novakovski, Kazuaki Makita, Tokayoshi Moriyama

Summary

A LED lamp has been exclusively designed with the purpose of providing the painting of *Mona Lisa* in the Louvre Museum in Paris, with the highest possible quality of lighting. The Japanese firm Toshiba financed this new design. The new lamp is installed in a shelf designed by the room's architect (Lorenzo Piqueras, 2005) and works upward. It is composed of 34 LEDs (single chip and multi chips) and replaces the former lamp from 2005, containing 7 LEDs. Three optical systems have been developed in order to obtain a high uniformity of illuminances on the painting: primary optics on the LEDs, a "Scheib" mixing the colours, and a third system consisting of a double lens with an integrated filter, focusing the light on the painting and regulating its quality. A framer was also incorporated. The other aim of this lamp is to control freely the colour temperatures, keeping a high CRI (>95) with a maximum Gamut Area (in relation to the scientific research of the International Lighting Commission).

This is realized without producing any infrared or ultraviolet radiation. A smart command system was developed which allows the Louvre Museum to adjust the spectrum of the light (deviation Duv), with an easy and precise process..

These changes are mainly useful for adjusting the coloration caused by the protection glass and to the surrounding luminous environment, and secondly to obtain the best rendering.

Finally, the lamp benefits from an extremely powerful cooling system which stabilises the mixes of colour and offers a life of 80 000 hours. Owing to the use of the last generation of LEDs, this lamp consumes only about 20 watt when operating

Introduction.

As part of the patronage from the firm Toshiba of the Louvre Museum, it has been decided to develop a new lamp with very high performances in order to add a complementary lighting of the painting *Mona Lisa*.

A special development team was gathered and the ARKANZ firm has dealt with the execution of the product. This document presents the solutions developed by this team. This lighting equipment was installed on 4 June 2013.

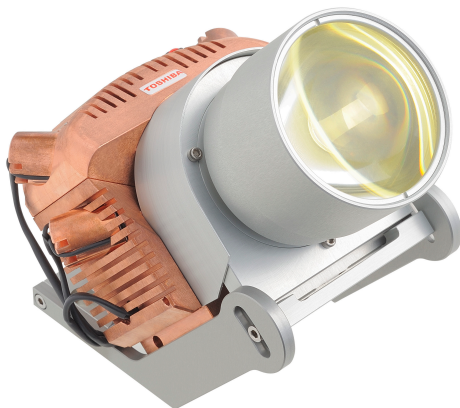

Figure 1: TOSHIBA lamp 2013 with 34 LED designed to light the painting of *Mona Lisa*.

Original lighting principles and functional requirements of the new lamp.

Marc Fontoynt, Consultant, Professeur, Aalborg University, Copenhagen, Denmark.

In 2005, Architect Lorenzo Piqueras was in charge of the renovation of the "La Joconde Room" at the Louvre Museum and Marc Fontoynt was responsible for the lighting. It had been decided that the painting of *Mona Lisa* should not be lighted in an ostentatious way, and that the way it is represented should closely resemble the one used for the neighbouring paintings. The painting's position on a specific wall and behind a thick plate of laminated glass required a lighting system providing colour adjustments to be added. The upward lighting from the shelf allows the lamp to be hidden and avoids risks of reflections.

In the renovation conducted in 2005, we realized that a lighting system based on multiple LED could efficiently provide the chromatic corrections needed (optimal rendering of colours, compensation of coloration due to the thickness of the glass plate, and need to take into account the surrounding lighting). Designing a LED lamp short enough to be inserted in the shelf was a major constraint. The lamp designed in 2005 was composed of 7 LEDs and had already been the subject to a detailed colorimetric study.



Figure 2: Lamp with 7 LED developed by ARKANZ-SKLAER GmbH in 2005 (Project Arch. L. Piqueras / Lighting M.Fontoyntont)

In 2013, lighting techniques have progressed, so did knowledge in colorimetry. Consequently, it has been possible to push the challenge even further:

- With LEDs of high luminous efficacy, and better spectral distribution
- With more precise optics to significantly improve uniformity of illuminance distribution over the painting
- With an integrated framing with sharp edges
- With an integrated colour adjustment system, to allow simple and precise spectral adjustment
- With an increase of “Gamut Area”, to extend quality of display (based on CIE work)
- With a selection of techniques which could be deployed to all museums

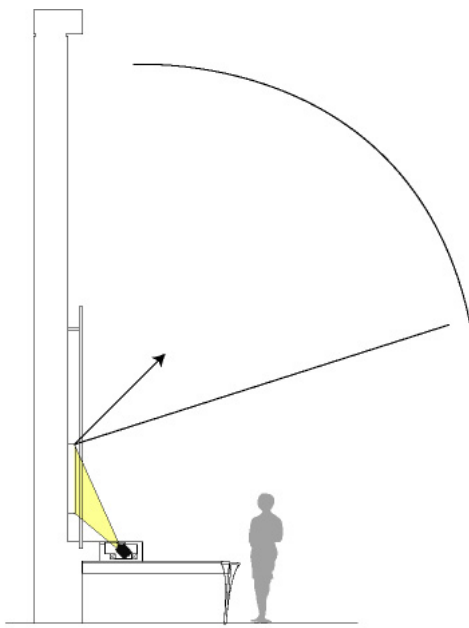

Figure 3: Upward lighting principle of Mona Lisa developed in 2005 (Architect Lorenzo Piqueras, Lighting Designer Marc Fontoyntont)

A state of the art lamp that draws on the best available technology and know-how .

Jean-Pierre Miras, CEO, Arkanz Lighting GmbH / Sklaer GmbH , Francfort, Germany

The first lamp developed for La Joconde by Sklaer GmbH (an Arkanz affiliate) in 2005 had 7 LEDs, a FOCON type colour mixer-converter (Fibre Optics Converter), and an active cooling system using a permanently functioning fan. Each channel was driven individually in constant current. It operated for over 70,000 hours without failure.

The development of the new lamp, managed by Arkanz Lighting in close cooperation with TOSHIBA Lighting, has called for innovative technological solutions: 34 LEDs are positioned in a star configuration in order to ensure chromatic homogeneity across the painting. The spectral distributions of the LEDs have been carefully chosen in order to achieve a very high Colour Rendering Index (CRI) of up to 98 on the required temperature colour range. The cooling of the lamp is ensured by a massive copper heat sink in combination with a fan to limit the chromatic variations as much as possible and to guarantee the spectrum over the required life time.

One of the major challenges was to mix colours over a very short 12cm distance. This was made possible by Partner Company Fraen srl integrating a Scheib optical fibre mixer in the mixing and projection optical system. (See following articles).

The current driving system has been designed by the company DEF srl (Lombardy, Italy). DEF was also responsible for the assembly and the quality management with UL International Italy. Two D-LED Push type constant current DALI drivers have been used for colour mixing and interference free dimming. The Push is a very compact multi channel current driver specially adapted for LEDs lamps; it has with a DALI or 0/10V interface and an overheating control loop.

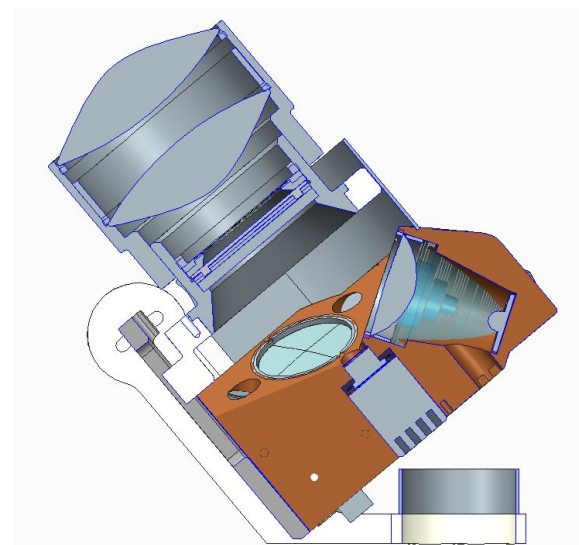

Figure 4 New TOSHIBA Mona Lisa projector, Design Vittorio Ferri, 2013

A CP64-LX-C standard controller from the Company AELSYS (PACA region, France) is used to control the drivers and store the scenarios. Aelsys develops and manufactures DALI and DMX controllers that can be interfaced with external sensors as light control and presence detectors. In Le Louvre, the controller is connected via an Ethernet link to the main bus of the Museum

The configuration software (WINCIP) has been modified to integrate a colorimetric module; this module can automatically set the levels in the 7 groups of LEDs modules once you have chosen the following three parameters: colour temperature, luminous intensity and deviation from the black body locus. AELSYS has developed an application on Windows 8 to link the CP64-LX-C with a Toshiba tactile PC/Tablet, via Wifi or an USB3 link.

With this „concept lamp " Arkanz Lighting and its partner companies have studied and implemented a number of technological solutions that are the subject of patents and open the way for new powerful and high-performance museum projectors.

Optical optimisation for an excellent uniformity across the painting.

Marco Angelini ,MD & CTO de Fraen Corporation Srl, Italy.

In the former 2005 LED lamp model, the projection lens was a single aspheric lens with a 0,8 numerical aperture. The shape of the beam was created using a fibre optics converter with a trapezoidal output whose rectangular projection coincided exactly with the painting of La Jocard.

For the new 2013 LED lamp, the main multi-sources structure has been retained although the spatial distribution has been improved, to increase the homogeneity of both colour and intensity.

The number of LEDs has been increased from 7 to 34, set up as 7 "single-chips" and 3 "multi-chips" each one consisting of 9 chips.

The colour mixing is achieved through three successive steps:

- 1) The first "pre-mix" step is based on specific FRAEN optical components for LED colour mixing (FRAEN - FCM-M1+FCX Patent Pending Appl. N. WO2010US23071 20100203),
- 2) The second step uses a "Scheib" optical system (see colours/Scheib mixture section)
- 3) The third step uses a special (SF)³ diffusing filter.

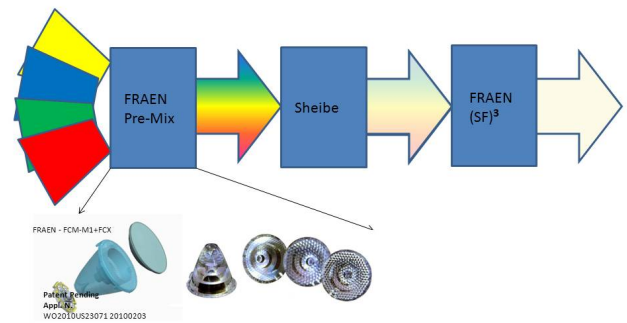

Figure 5. Details of the colour mixing optical train that guarantees lighting uniformity across the screen.

A "Pre-mix" optical system allows the beam from the 34 LED-source to focus on a disk that creates a high-homogeneity luminous spot. The dimensions of the luminous spot are optimised in relation to the size of the La Jocard painting.

Downstream of the "Scheib" mixer we have chosen to position a trapezoidal cut-off diaphragm in the focal plane of the projection system. This allows a rectangular-form spot to be projected on to the screen plane which is not orthogonal to the optical axis of the lamp.

The former lamp used an aspheric single projection lens. The new lamp is equipped with a special-design aspheric-symmetrical doublet. This doublet has a Numerical Aperture of 0.7. The design of this new two-lens system was necessary to eliminate the distortion on the upper side of the asymmetrical projection of the beam. This resulted in obtaining a very well defined rectangular spot on the painting. Furthermore, a careful fine tuning, of the system offers the possibility of monitoring the contrast between the illuminated part (the painting) and its frame.

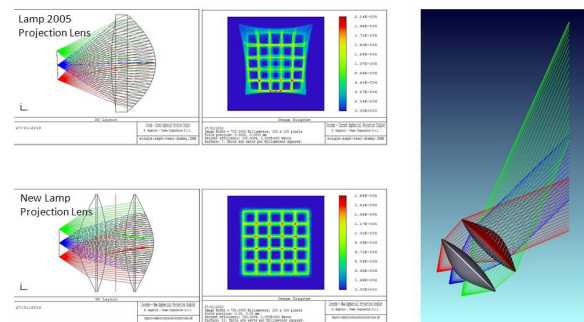

Figure 6. Asymmetric projection doublet guarantees uniform light distribution properly shaped on the screen.

To manage the luminous fade from the illuminated area to the dark area, the team decided not to light up the frame but to make a slightly fuzzy "cut-off edge" to create a "soft" profile.

The uniformity of the screen lighting is one of the most noticeable spot performances of the 2013 model.

Because the lamp optical axis forms an approximately 60 degrees angle with the normal of the painting plane, the risk was to have the lower part significantly brighter than the upper part. To avoid this problem, in addition to the pre-mix, the Scheib and the doublet systems, it was necessary to develop a further special filter, named (SF)³, to balance more precisely the distribution of light on the painting. This (SF)³ filter can be designed for wide variety of angles of incidence along both X,Y directions and for different optical specifications.

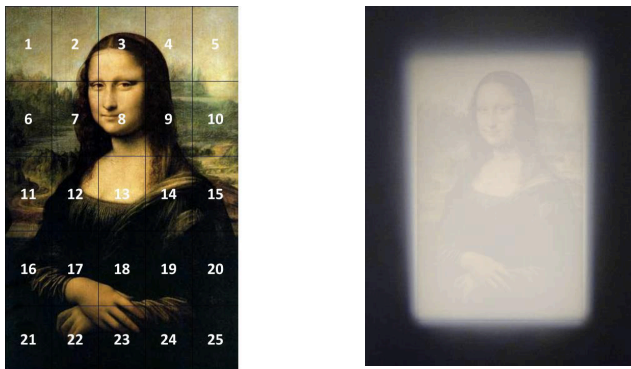

Figure 7. The light measurements on the painting show a uniformity of 0.85 with the lamp alone) and 0.92, taking the ambient light into account.

LED Colour Mixing: Technology Using Fibre-Optic Parallel-Sided Plate («Scheib»)

Leonid Novakovsky, Pharos-Alef, Moscow

Colour mixing of 34 LED sources in the new spotlight for *Mona Lisa* is carried out by means of the device that enables the spotlight size to be reduced. It represents a fibre-optic parallel-sided plate («Scheib») and uses the same principle of operation as in the FOCON of the previous spotlight, but with more sophisticated diaphragms. It consists of a bunch of optical fibres with high both fill factor and high angular aperture, and which is 4 mm thick. The big aperture (0.5) allows LED modules to be arranged in a wide cone of $\pm 32^\circ$. Testing this device shows that colour mixing of very high quality takes place there, and as a result of that the uniformity of illumination would run close to 95 %.

The fibre-optic plate («Scheib») is used for light beam transmission and image shaping when an application demands precise light distribution in small space. This elegant technology is successfully used for shaping a mobile light beam pattern in original headlight designs and is the subject of the patent application submitted by Pharos-Alef Ltd. and Sklaer GmbH (patent N 2283986).

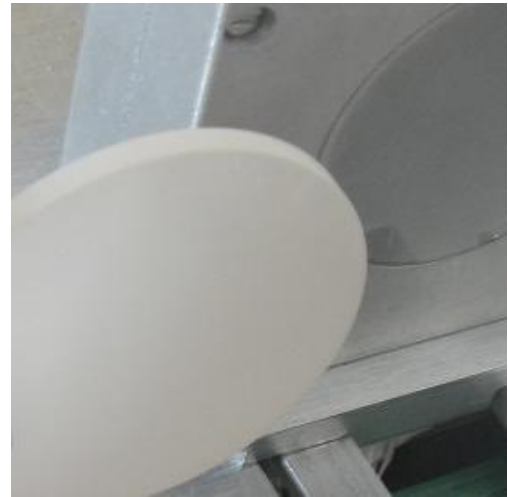

Figure 8: Fibre-optic plate «Scheib»
(Photo by Sklaer GmbH)

Total control of spectra and luminous power

Christophe Marty, Gregory Duchêne, INGELUX, Lyon France

Two different pilot modes were suggested: the first one dedicated to colorimetric adjustments before the final on-site delivery and the second one for current operation, and interfaced with the DALI protocol employed in the Louvre Museum.

The first aspect was particularly relevant concerning the innovation.

We have designed a colorimetric tool, in line with the ongoing research of the *International Council of Museums* (ICOM) and the *International Lighting Commission* (CIE). This tool allows us to navigate in the colorimetric space, to freely control the chromatic coordinates of emitted light while disposing at any time of a light with an optimal quality (high Colour Rendering Index and maximal Gamut Area). The development of this software has required spectral calibration of each colour channel, corrections due to optical systems, using integrating sphere.

However, the conservation Department of the Louvre Museum had to make final decisions concerning these adjustments; we have elaborated a protocol for on-site adjustment, in front of the painting of *Mona Lisa*. The final adjustment has been decided by the curator, Vincent Delieuvin, assisted by the architect of the «La Joconde Room» Lorenzo Piqueras, under mixed general lighting conditions (fluorescent light with a little bit of natural light).

It is essential to insist on the innovative process, allowing the curator to adjust the light and colours on a painting, to render with high fidelity, the exact colours of the work.

The process that we elaborated would deserve to be in many museums, at least where the art curators would like to adjust the lighting: a) because of the deterioration of the

painting, b) because the general lighting conditions are inappropriate and do need a localised chromatic correction.

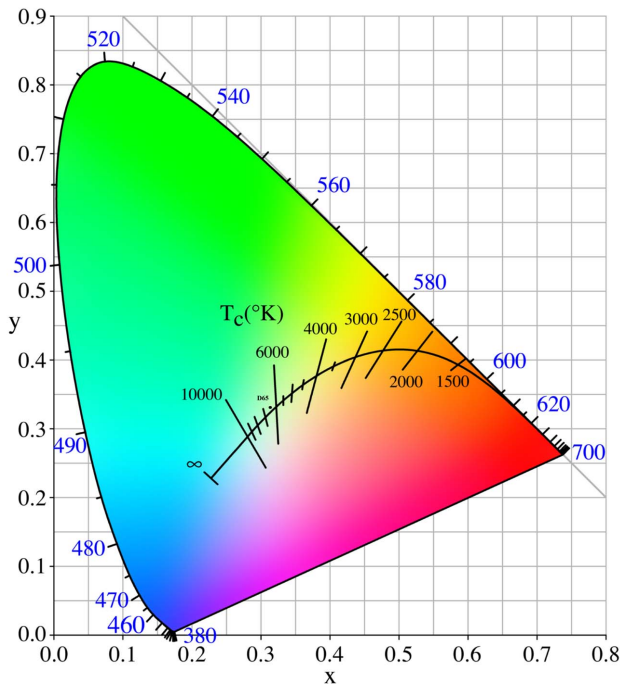

Figure 9: The controlling system offers the highest quality of lighting for all the operating points situated on a wide range of temperatures. A high Gamut Area is reached with a large number of LEDs (34). The navigation on the diagram is made by the Ingelux designed pilot, based on established knowledge.

The highest quality LED lamp in the world.
 Kazuaki Makita, TOSHIBA Corporation, Chief Specialist

The Toshiba group started new activities regarding lighting in April 2010 in order to create a new worldwide “lighting culture”. Within the framework of the first renovation project of lighting outside the museum, we signed a contract in partnership with the Louvre Museum (from 30 June 2010 to 31 December 2013). The lighting of the Pyramide, the Pyramidions and the Pavillon Colbert have been replaced by LED lightings on 6 December 2011, whereas the lightings retrofit (with LEDs) of the Cour Napoléon took place on 24 May 2012. Today, the work is progressing in order to deliver the lightings of the Cour Carrée by the end of 2014.

This renovation project of external lighting is not limited to a simple technological support job, but has maintained a worldwide cultural heritage in a “more sustainable and nicer way”, to achieve the “fusions of arts and technology” and to reduce electrical consumption to 73%.

The Louvre Museum acknowledges that we have succeeded in combining the “reduction of environmental charges and the revalorisation of arts”. This explains why we could sign a new partnership contract on the renovation

project dealing with the lighting of the interior of the Museum in May 2012.

This time, a series of lighting will be replaced by LED lamps, starting with the lights of the *Mona Lisa*, called the treasure of the Louvre Museum, the ones in the “Red Room” where we find famous large-scale paintings (for example the *Couronnement de l’Empereur et de l’Imperatrice*). We will also replace the light situated at the entrance of the Napoleon Hall, more precisely at the entrance of the Museum.

The specific lamp of *Mona Lisa* was expected to be replaced in June 2013, together with the luminaires of the Red Room, and that the lighting of the Napoleon Hall will be renovated before mid-2014.

At the beginning, Toshiba had planned to design a new lamp, to replace the specific lamp lighting *Mona Lisa*, and developed in 2005 by the German company ARKANZ-SKLAER..

Toshiba has decided to develop an innovation lamp, based on the latest technology of LEDs, and benefiting from progresses in optics. It launched a project to gather the best available technologies to develop a lamp of the best possible quality.

A close monitoring of the technical team.
 T. Moriyama, TOSHIBA Lighting & Technology Corporation Corporation Senior Specialist

Toshiba began to investigate, in 2012, the possibility to develop a new lamp to light *Mona Lisa*. To improve the performance of the former lamp, we conducted a feasibility study during two months after June 2012, together with the German company ARKANZ GmbH, and we began to launch technological developments on the following points:

- 1) assess possible technologies to control fluxes, CCT, Duv and CRI
- 2) investigate technical solutions to improve uniformity of illuminance on *Mona Lisa*, as well as the uniformity of spectral distribution over the painting.
- 3) Investigate solutions to provide a perfect framing at the edge of the rectangular painting
- 4) Identify ways to limit drastically any production of UV radiation and Infra-Red.

A first prototype has been built in January 2013. The operation of the lamp was tested in real conditions, in front of *Mona Lisa*, with the participation of the curator of the XVth century Italian painting, Vincent Dieulevin, and the Architect of “*Salle de la Joconde*”, Lorenzo Piqueras. In February, the final spectral distribution of the lamp, as well as the luminous flux, were determined through on-site tests.

Museum, for his careful monitoring of the project and his active participation in the exchanges

Statement by the Curator of the XVI century Italian Paintings, Louvre Museum.

Vincent Delieuvin,

In the Louvre Museum, particular attention is paid to the lighting so that every object of art receives the proper lighting. Each painting deserves to be looked at in the best conditions of lighting, which might be useful to understand the pictorial technique of the artist or to admire the subtlety of his palette.

However, the lighting has to adapt to multiple constraints. For example: time could have deformed the structure, altered the pigments or damaged the varnish.

Furthermore, the glass protection of certain pieces of art, necessary for their security, can disturb the visibility if the surrounding space reflects into the glazing.

More or less all these constraints are present in the case of *Mona Lisa* and in a very acute manner.

Over the past 500 years, the wooden panel has lost its shape and taken a convex form. As a result, a complex network of cracks has appeared, damaging the subtle work of Leonardo da Vinci. The different coats of varnish laid down on the painting had oxidized, darkened and yellowed the colour range. Finally, the protective glazing, particularly thick for this painting, adds a coloured filter, which lighting has to compensate.

The Louvre Museum would like this major artistic world heritage to benefit from the best available lighting techniques

We are delighted that the painting has benefited from the latest innovations in the lighting domain, thanks to the partnership with Toshiba. This approach is part of the spirit of experimentation and the spirit of Leonardo de Vinci.

Statement by the Director of the Architecture, Louvre Museum

Sophie Lemonnier

The building of the Louvre Museum is in permanent change. Even today, the special design of the new lamp for the *Mona Lisa* is the result of an iterative collaboration between renowned specialists.

If in 2005 a new modern spot for the *Mona Lisa* was designed for the reopening of the *Salle des États*, today it is thanks to Toshiba's involvement, famous specialists gather again. We are delighted to present today the painting showing the benefits of the latest of lighting technology.

The authors are thankful to *Jean-Louis Bellec*, Chief of Service at the Architecture Department of Louvre

Parameters	Specifications	TOSHIBA Lamp (English)
CCT with high CRI	2700 to 3800 K	Adjustable from 2700 K until 3800 K <i>3200K selected for Mona Lisa</i>
Colour shift from locus	N/A	Adjustable from -0,02 to 0,01
Luminous Flux (lm)	N/A	88 lm selected from <i>Mona Lisa</i> (can be boosted to 400 lm)
CRI	> 90	CRI between 95 and 98 when on locus
Colour Quality Scale (CQS)	> 85	> 95 for <i>Mona Lisa</i> > 85 maintained for various CCT between 2700 K and 3800 K
Ultra Violet radiation	< 5 µW/lm	< 3 µW/lm
Infra-Red Radiation	< 0.1 W	< 0.05W
Uniformity on painting $E_{min}/E_{average}$	> 0.6	0,85 (with 16 points) > 0,92 with ambient lighting
Vertical Uniformity on painting	> 0.9	0,93 $E_{half\ top\ over\ E_{average}}$
Average Illuminance	100-250 lx spot + ambient	180 lx on glass / 108 lx on painting (spot only)
Luminous Flux projected outside frame	<1%	< 0,5%
Lamp Life	>50 000 heures	~ 80,000 hours

Figure 10. Performances of the TOSHIBA La

Addresses and useful links:

Marc Fontoynt, Consultant and Professor, Aalborg University, Copenhagen, Denmark.
mrf.lights@gmail.com

Jean-Pierre Miras, CEO, Arkanz Lighting GmbH.,
www.arkanz.com, www.sklaer.com

DEF S.r.l., Paolo de Vecchi
www.defsrl.it

Aelsys Sarl. Jean Chanussot
www.aelsys.fr

Marco Angelini, CEO Fraen S.r.l. Italy,
www.fraen.com

Leonid Novakovskij, CEO Pharos-Alef, Russia
www.pharos-alef.ru

Christophe Marty, Gregory Duchêne
Ingélux Lighting Consultants, Vaulx en Velin Lyon,
c.marty@ingelux.com, www.ingelux.com

*Kazuaki Makita, Chief Specialist, New Lighting Systems
Division, Toshiba, Tokyo, Japan.
kazuaki.makita@toshiba.co.jp*