

NAT'L INST. OF STAND & TECH  
A11106 395869

NIST  
PUBLICATIONS



# NIST SPECIAL PUBLICATION 260-140

U.S. DEPARTMENT OF COMMERCE/Technology Administration  
National Institute of Standards and Technology

*Standard Reference Materials:*

**Technical Specifications for Certification of  
Spectrophotometric NTRMs**

**John C. Travis, Melody V. Smith,  
Stanley D. Rasberry, and Gary W. Kramer**

QC  
100  
U57  
.260-140  
000

**T**he National Institute of Standards and Technology was established in 1988 by Congress to “assist industry in the development of technology . . . needed to improve product quality, to modernize manufacturing processes, to ensure product reliability . . . and to facilitate rapid commercialization . . . of products based on new scientific discoveries.”

NIST, originally founded as the National Bureau of Standards in 1901, works to strengthen U.S. industry’s competitiveness; advance science and engineering; and improve public health, safety, and the environment. One of the agency’s basic functions is to develop, maintain, and retain custody of the national standards of measurement, and provide the means and methods for comparing standards used in science, engineering, manufacturing, commerce, industry, and education with the standards adopted or recognized by the Federal Government.

As an agency of the U.S. Commerce Department’s Technology Administration, NIST conducts basic and applied research in the physical sciences and engineering, and develops measurement techniques, test methods, standards, and related services. The Institute does generic and precompetitive work on new and advanced technologies. NIST’s research facilities are located at Gaithersburg, MD 20899, and at Boulder, CO 80303. Major technical operating units and their principal activities are listed below. For more information contact the Publications and Program Inquiries Desk, 301-975-3058.

---

### **Office of the Director**

- National Quality Program
- International and Academic Affairs

### **Technology Services**

- Standards Services
- Technology Partnerships
- Measurement Services
- Technology Innovation
- Information Services

### **Advanced Technology Program**

- Economic Assessment
- Information Technology and Applications
- Chemical and Biomedical Technology
- Materials and Manufacturing Technology
- Electronics and Photonics Technology

### **Manufacturing Extension Partnership Program**

- Regional Programs
- National Programs
- Program Development

### **Electronics and Electrical Engineering Laboratory**

- Microelectronics
- Law Enforcement Standards
- Electricity
- Semiconductor Electronics
- Electromagnetic Fields<sup>1</sup>
- Electromagnetic Technology<sup>1</sup>
- Optoelectronics<sup>1</sup>

### **Chemical Science and Technology Laboratory**

- Biotechnology
- Physical and Chemical Properties<sup>2</sup>
- Analytical Chemistry
- Process Measurements
- Surface and Microanalysis Science

### **Physics Laboratory**

- Electron and Optical Physics
- Atomic Physics
- Optical Technology
- Ionizing Radiation
- Time and Frequency<sup>1</sup>
- Quantum Physics<sup>1</sup>

### **Materials Science and Engineering Laboratory**

- Intelligent Processing of Materials
- Ceramics
- Materials Reliability<sup>1</sup>
- Polymers
- Metallurgy
- NIST Center for Neutron Research

### **Manufacturing Engineering Laboratory**

- Precision Engineering
- Automated Production Technology
- Intelligent Systems
- Fabrication Technology
- Manufacturing Systems Integration

### **Building and Fire Research Laboratory**

- Structures
- Building Materials
- Building Environment
- Fire Safety Engineering
- Fire Science

### **Information Technology Laboratory**

- Mathematical and Computational Sciences<sup>2</sup>
- Advanced Network Technologies
- Computer Security
- Information Access and User Interfaces
- High Performance Systems and Services
- Distributed Computing and Information Services
- Software Diagnostics and Conformance Testing
- Statistical Engineering

---

<sup>1</sup> At Boulder, CO 80303.

<sup>2</sup> Some elements at Boulder, CO.

# NIST Special Publication 260-140

*Standard Reference Materials:*

## Technical Specifications for Certification of Spectrophotometric NTRMs

John C. Travis and Melody V. Smith

Analytical Chemistry Division  
Chemical Science and Technology Laboratory

Stanley D. Rasberry (retired)

Office of Measurement Services  
Technology Services

and

Gary W. Kramer

Analytical Chemistry Division  
Chemical Science and Technology Laboratory

National Institute of Standards and Technology  
Gaithersburg, MD 20899-0001



---

U.S. DEPARTMENT OF COMMERCE, William M. Daley, Secretary  
TECHNOLOGY ADMINISTRATION, Dr. Cheryl L. Shavers, Under Secretary of Commerce for Technology  
NATIONAL INSTITUTE OF STANDARDS AND TECHNOLOGY, Raymond G. Kammer, Director

Issued February 2000

**National Institute of Standards and Technology Special Publication 260-140**  
**Natl. Inst. Stand. Technol. Spec. Publ. 260-140, 59 pages (Feb. 2000)**  
**CODEN: NSPUE2**

**U.S. GOVERNMENT PRINTING OFFICE**  
**WASHINGTON: 2000**

## **Abstract**

This document provides the technical requirements for operating laboratories that prepare, measure, and certify visible absorbance spectrophotometric NIST Traceable Reference Materials (NTRMs) with quality assessment administered by the National Voluntary Laboratory Accreditation Program (NVLAP) of the National Institute of Standards and Technology (NIST). Specifically, descriptions are given of the processes involved in qualifying a potential NTRM certifier, detailed specifications and construction of NTRM filters, the spectrophotometric certification and recertification process, and maintaining measurement traceability to the reference spectrophotometer in the NIST Analytical Chemistry Division. Measurement traceability is assured through direct and indirect proficiency testing, including annual comparison measurements, control charts using certified NIST Standard Reference Materials and in-house working standards, and blind testing.

## **NIST Commercial Disclaimer**

Certain commercial equipment, instruments, and materials are identified to describe adequately the work presented herein. Such identification does not imply recommendation or endorsement by NIST, nor does it imply that the equipment, instruments, or materials are necessarily the best available for the purpose.

## **Copyright**

This article is a U.S. Government work and, as such, is in the public domain in the United States of America.

## **Keywords:**

absorbance, neutral density, optical filter, reference material, spectrophotometry, traceability, transmittance.



# Foreword

The National Institute of Standards and Technology (NIST), formerly the National Bureau of Standards, was established by the U.S. Congress in 1901 and charged with the responsibility for establishing a measurement foundation to facilitate both U.S. and international commerce. This charge was purposely stated in broad terms to provide NIST with the ability to establish and implement its programs in response to changing national needs and priorities.

Increased requirements for quality systems documentation for trade and effective decision-making regarding the health and safety of the U.S. population have increased the need for demonstrating “traceability-to-NIST” and establishing a more formal means for documenting measurement comparability with standards laboratories of other nations and/or regions. Standard Reference Materials (SRMs) are certified reference materials (CRMs) issued under the NIST trademark that are well-characterized using state-of-the-art measurement methods and/or technologies for chemical composition and/or physical properties. Traditionally, SRMs have been the primary tools that NIST provides to the user community for achieving chemical measurement quality assurance and traceability to national standards. Currently, NIST catalogs nearly 1300 different types of SRMs covering 29 technical categories. Since it has the world's leading, most mature, and most comprehensive reference materials program, most of the world looks to NIST as the de facto source for high quality CRMs for chemical measurements.

NIST has met the reference materials needs of U.S. industry and commerce for nearly 100 years. While our reference materials program has focused primarily on U.S. requirements, it is clear that these materials address international measurement needs as well. As the demonstration of quality and “traceability” for chemical measurements have become increasingly global issues, the need for internationally recognized and accepted CRMs for chemical composition has increased correspondingly. Their use is now often mandated in measurement/quality protocols for analytical testing laboratories. The fast pace of technological change coupled with increased demands on quality, traceability, and SRM types have required NIST to devise new strategies for customers to obtain measurement linkage to NIST. With a shift in paradigm NIST will be able to more effectively address future needs for reference materials, both nationally and internationally.

The NIST Traceable Reference Materials (NTRM) program was created to address the problem of increasing needs for reference materials with a well-defined linkage to national standards. An NTRM is a commercially produced reference material with a well-defined traceability linkage to existing NIST chemical measurement standards. This traceability linkage is established via criteria and protocols defined by NIST and tailored to meet the needs of the metrological community to be served. The NTRM concept was implemented initially in the gas standards area to allow NIST to respond to increasing demands for high quality reference materials needed to implement the “Emissions Trading” provisions of the Clean Air Act of 1990. The program has been highly successful in providing over 400,000 NIST traceable gas standards to end users at a cost benefit ratio of 1:70.

This document provides the technical requirements for operating laboratories that prepare, measure, and certify visible absorbance spectrophotometric NIST Traceable Reference Materials

(NTRMs). The operational aspects of this NTRM program that pertain to NTRM producers' laboratory accreditation through the NIST National Voluntary Laboratory Accreditation Program (NVLAP) are detailed elsewhere in NIST Handbook 150-21.

Willie E. May, Chief  
Analytical Chemistry Division  
Chemical Science and Technology Laboratory

Thomas E. Gills, Director  
Office of Measurement Services  
Technology Services



# Technical Specifications for Certification of Spectrophotometric NTRMs

## Table of Contents

<b>1. INTRODUCTION</b>	<b>1</b>
1.1 NIST Traceable Reference Materials	4
1.2 NIST Spectrophotometric Standard Reference Materials	4
1.3 Neutral Density Glass NTRMs	5
<b>2. CERTIFIER QUALIFICATION</b>	<b>6</b>
2.1 Coordination with NVLAP	7
2.2 Facilities	7
2.2.1 Transfer Spectrophotometer	7
2.2.2 Means of Verifying Optical Specifications	9
2.3 Prototype Batch	10
2.4 Assignment of Uncertainties	10
2.5 Rights and Terms of Accreditation	11
<b>3. PRODUCTION OF SPECTROPHOTOMETRIC NTRMS</b>	<b>11</b>
3.1 Filter Glass	12
3.1.1 Optical Specifications	12
3.1.2 Rejection of Out-of-Specification Materials	14
3.2 Filter Holders	14
3.3 Set Containers	16
3.4 Identification Marking	16
3.5 Assembly of Sets	17
<b>4. CERTIFICATION AND RECERTIFICATION OF NTRMS</b>	<b>18</b>
4.1 Rejection and Replacement of Filter Materials	18
4.1.1 Uniformity Testing	18
4.2 Spectrophotometric Certification Measurements	19
4.2.1 Environmental Control	20
4.2.2 Certification Wavelengths and Bandwidths	20

4.2.3 Instrumental Parameters and Measurement Protocol	21
4.2.4 Measurement Data	27
4.2.5 Revision of Measurement Parameters or Protocols	27
4.3 Aging Protocol	27
4.3.1 Precertification Measurements	28
4.3.2 Stability Approval and Certification	28
4.4 Certification Measurement	29
4.5 Recertification	29
4.6 Documentation	31
<b>5. TRACEABILITY TO NIST</b>	<b>32</b>
5.1 The Traceability Chain	32
5.2 NIST SRMs	32
5.2.1 Storage and Measurement Frequency	33
5.2.2 Wavelength Calibration	34
5.3 NTRM Certifier Standards	34
5.4 Control Charts	34
5.5 Annual Comparison of Transmittance Scales	36
5.6 Lot Samples and Blind Testing by NIST	36
5.7 Reporting Measurement Data to NIST	36
5.7.1 Data to be Reported	37
5.7.2 Metadata to be Reported with Each Data Record	37
5.7.3 Structure of a Data Record	38
5.7.4 Frequency of Reporting Data to NIST	38
5.7.5 Mechanism for Reporting Data to NIST	39
5.8 Accreditation Review	39
<b>6. FEES AND REVIEW OF FEE STRUCTURE</b>	<b>39</b>
<b>REFERENCES</b>	<b>41</b>
<b>APPENDIX A. WORKSHOPS ON NIST TRACEABILITY IN CHEMICAL SPECTROPHOTOMETRY</b>	<b>A1</b>
<b>APPENDIX B. DESIGN OF HOLDERS FOR OPTICAL FILTERS SRMS.</b>	<b>B1</b>
<b>APPENDIX C. DESIGN OF SHIPPING AND STORAGE CANISTERS AND SPRINGS FOR OPTICAL FILTERS SRMS.</b>	<b>C1</b>

# Technical Specifications for Certification of Spectrophotometric NTRMs

## 1. INTRODUCTION

This document provides the technical requirements for operating laboratories that prepare, measure, and certify visible absorbance spectrophotometric NIST Traceable Reference Materials (NTRMs). NIST traceability for these materials is assured through the National Voluntary Laboratory Accreditation Program (NVLAP) of NIST, as described in NIST Handbook 150, *NVLAP Procedures and General Requirements*, and NIST Handbook 150-21, *Chemical Calibration: Certifiers of Spectrophotometric NTRMs*. These two documents present the specific requirements for accreditation of laboratories that produce spectrophotometric filters.

The spectrophotometric neutral density glass filter NTRMs discussed in this document and Handbook 150-21 may be referred to by the short title "filter NTRMs." The filter NTRMs referred to in this document are neutral density glass filters certified for visible absorbance. A glossary of terms as used in this document is given in Table 1, for the convenience of the reader. Certain terms have been defined to provide for consistency in operating this program, realizing that they may have additional usages within the field.

**Table 1**  
Glossary of Terms Used in SP 260-140

---

---

Absorbance	Negative logarithm of the transmittance; used interchangeably with "transmittance density" in this document, but always for an air blank. Normally associated with the "internal transmittance" in chemical usage.
ACD	The NIST Analytical Chemistry Division.
Blank	In the present context, the blank is taken to be an empty filter holder, so that the reference beam passes through air but is subject to an identical geometry to the sample beam at the periphery. In more typical chemical usage, the blank may be a cuvette containing a matrix fluid appropriate to the sample and yielding an "internal transmittance" and traditional absorbance corrected for external reflections.
Certifier	The term used to denote a company that has been approved by the ACD and accredited by NVLAP to prepare, certify, market, and recertify filter NTRMs.

Cuvette	A cell for containing liquid samples and blanks for measurements in chemical spectrophotometers. The dimensions are highly standardized, and the exterior dimensions are identical to the NTRMs.
Double-beam	A descriptor of a spectrophotometer in which the blank and the sample are measured virtually simultaneously, in two nominally equivalent beams.
Dual Aperture	The implicit standard methodology used to calibrate the detector linearity of national reference spectrophotometers.
Filter	As used herein, refers to a partially transmitting optically finished solid artifact or sealed liquid-containing cuvette that may be conveniently inserted in the sample beam of a chemical spectrophotometer.
Filter NTRM	Short form for neutral density glass filter NIST Traceable Reference Material.
Internal Transmittance	Special case of transmittance corrected for reflective losses at the entry and exit interfaces of a liquid-containing cuvette or a solid glass absorbing filter.
NTRM	NIST Traceable Reference Material.
Optical Filter	Used synonymously with "Filter" in the present document.
Optical Wedge	The angular measure of the departure from perfect parallelism of the entry and exit interfaces of filter NTRMs and SRMs.
PMT	Photomultiplier tube; the detector commonly used in spectrophotometers.
Reference Beam	The optical path in a chemical spectrophotometer in which the blank would normally be placed, especially in a double-beam instrument
Reference Spectrophotometer	The custom-built ACD spectrophotometer used to maintain the regular transmittance scale for chemical spectrophotometry in the US.
Referred to...	Taken to indicate the nature of the blank. For the present purposes, all absorbance measurements are "referred to" air, and thus are entirely equivalent to "transmittance density" measurements.
Regular Transmittance	A special case of transmittance (see below) in which the transmitted radiant flux is not deflected upon passage through the sample.
Regular Transmittance Scale	The primary standard for regular transmittance as maintained by a National Measurement Institute (NMI) by means of a reference spectrophotometer. NIST maintains a scale in the ACD for chemical spectrophotometry and a scale in the Optical Technology Division for physical measurements.
Resolution	Often used interchangeably with bandwidth, but current usage – and usage in this document – involves measurement of a particular peak-to-valley ratio of transmittance in a specified sample.

Sample Beam	The optical path in a spectrophotometer in which the sample would normally be placed, especially in a double-beam instrument.
SED	The NIST Statistical Engineering Division.
Single-beam	A descriptor of a spectrophotometer in which the blank and the sample are measured sequentially, and the two "single-channel" spectra are divided to obtain the transmittance.
Slew-scan	The method of operation of a scanning spectrophotometer to yield measured values of transmittance and/or absorbance at a few discreet wavelengths, as for the certification of filter NTRMs.
Spectrophotometer	An instrument designed to measure the transmittance -- and hence by calculation the absorbance -- of partially transmitting materials at designated wavelengths. The expression "chemical spectrophotometer" or "chemical spectrophotometry" is used throughout this document to signify the class of instruments used primarily for chemical measurements and for which traceability to the regular transmittance scale maintained in the ACD is desired.
Spectrum	The ordered display of transmittance or absorbance readings at consecutive wavelengths.
SSW	Spectral slit width, also known as the spectral bandpass, spectral bandwidth, and instrument function; a measure of the monochromaticity of the light of a given spectrophotometer. Typically determined by the grating ruling density, the focal length, and the mechanical slit widths of the wavelength dispersion component of the instrument.
SRM	Standard Reference Material <sup>®</sup> ; a certified reference material issued only by the NIST.
STP	Standard temperature and pressure; 273 K and 101.325 kPa.
Stray light	Detected light that is inappropriate to the correct transmittance measurement. May be light of any wavelength that did not pass through the sample, or may be light of the wrong wavelength (whether or not it passed through the sample).
Transfer Spectrophotometer	A qualified high-resolution spectrophotometer that is systematically validated with respect to the ACD reference spectrophotometer and is used to certify and recertify filter NTRMs.
Transmittance	The ratio of the radiant flux transmitted through a sample to the radiant flux incident upon the sample, at a specified wavelength of light.
Transmittance Density	The absorbance when "referred to" an air "blank." Synonymous with "optical density" as used in optical metrology. Used interchangeably with "absorbance" in this document, but always referred to an air blank.

Wavelength	The metric by which the energy of UV and visible light is characterized, given by the distance in air at STP between consecutive maxima or minima in the electromagnetic wave.
------------	--

---

## 1.1 NIST Traceable Reference Materials

The program described in this document is for neutral density glass filters that are certified as visible absorbance spectrophotometric NTRMs and extends the concept of the NTRM to a new type of material. The original definition of an NTRM anticipated the extension of the concept to cover a variety of reference materials and is still quite valid:

A NIST Traceable Reference Material (NTRM) is a reference material produced by a commercial supplier with a well-defined traceability...to the National Institute of Standards and Technology (NIST). This traceability is established via criteria and protocols defined by NIST that are tailored to meet the needs of the metrological community to be served. The NTRM concept was established to allow NIST to respond to the increasing needs for high quality reference materials with constant human and financial resources. Reference material certifiers adhering to these requirements are allowed to use the "NTRM" trademark to identify their product.<sup>1</sup>

## 1.2 NIST Spectrophotometric Standard Reference Materials

Several Standard Reference Materials<sup>®</sup> (SRMs<sup>®</sup>) offered through the NIST Standard Reference Materials Program may be used for verifying the accuracy of the absorbance and transmittance scales of chemical spectrophotometers.<sup>2</sup> These materials are certified for absorbance at a number of wavelengths in the UV and visible spectral regions, using the National Reference Spectrophotometer built and maintained by the Analytical Chemistry Division (ACD) of NIST.<sup>3</sup> These SRMs are compatible with the sample holder commonly found in UV/visible chemical spectrophotometers that is designed to hold 10-mm pathlength sample cuvettes with a 12.5 mm square footprint. A liquid wavelength standard permanently sealed into a cuvette is also available. The spectrophotometric UV/visible SRMs are summarized in Table 2.

In Table 2 and throughout the text of this document, SRMs are referred to by number and without regard to a "series" or "lot" designation, which is usually given by a letter following the number. For instance, SRM 930 was first issued in 1970, and the series designation was incremented annually from SRM 930a to SRM 930d over the next few years. The designation was frozen at SRM 930d for a number of years, inasmuch as the production was seen to be essentially continuous, with no distinctive changes in specification. The latest series was incremented to SRM 930e, because the specification on optical wedge was tightened relative to the prior series. The series designation will not

be changed again until such time as a change is made in the specifications for the material.

SRM 931 is batch certified, by contrast, and each batch has slightly different assigned values than prior batches. The series designation is incremented each time the standard is issued, and the current issue is SRM 931f.

**Table 2**  
UV/Visible Spectrophotometric Standard Reference Materials

SRM	Material	Certified Property <sup>a</sup>	Levels	Wavelength/nm <sup>b</sup>
930	Neutral density glass	TD, T	3	440 to 635 (5)
931	Ni/Co nitrate solution	A	3	302 to 678 (4)
935	Potassium Dichromate	A	10	235 to 350 (4)
1930	Neutral density glass	TD, T	3	440 to 635 (5)
2030	Neutral density glass	TD, T	1	465 (1)
2031	Metal on Fused Silica	TD, T	3	250 to 635 (10)
2032	Potassium Iodide	T	NA	240 to 275 (8)
2034	Holmium-oxide Solution	Peak Positions/nm	NA	241 to 265 (14)

<sup>a</sup>T = transmittance; TD = transmittance density; A = (internal) absorbance.

<sup>b</sup>Number of wavelengths for which certified values are given is in parentheses.

SRMs 930 and 1930 are the relevant NTRMs for the production of filter NTRMs, and there is little reason to prefer SRM 930e over prior series, for certifiers who already own sets of SRMs. Indeed, older filters may be more stable than newer ones due to the completion of surface reactions, and hence may be superior control materials.

### 1.3 Neutral Density Glass NTRMs

A series of workshops was held at NIST to formulate the concepts of the first spectrophotometric NTRM program, as detailed in this document. Appendix A describes the first of these workshops, whose attendees were technically knowledgeable representatives of spectrophotometer manufacturers, manufacturers of optical filters/cuvettes/liquid reference materials, relevant measurement services laboratories, and end users of spectrophotometric reference materials from such user communities as clinical laboratories, pharmaceutical manufacturers, chemical manufacturers, etc. From the beginning, the workshop attendees supported the NIST suggestion to develop NTRM neutral density glass absorbance filters first and then eventually to expand the NTRM spectrophotometric filters into other areas. The neutral density glass NTRMs (referred to as filter NTRMs throughout this document) are to be closely related to SRMs 930, 1930, and 2030 shown in Table 2 and are traceable to NIST through SRMs 930 and 1930 (since SRM 2030 is a special case filter of SRM 930). Initially, filter NTRMs will share the

nominal transmittance levels and certification wavelengths of SRM filters. This restriction may eventually be eased to permit the production of filter NTRMs at other nominal transmittances and wavelengths within the ranges spanned by SRM filters. Within the current framework, a given certifier may choose to offer fewer transmittance levels and/or certification wavelengths than NIST offers, but may not offer more of either.

For any prospective filter NTRM certifier, the program as described in this document involves two phases. The first phase is a startup phase, involving qualification and approval, and the second phase is one of production, certification, and recertification of filter NTRMs with periodic renewal of accreditation and NIST approval. Over-riding both phases is the necessity of assuring all parties involved – from the end user to the filter NTRM certifier to the NIST ACD – that NIST traceability of filter absorbance measurements to the primary absorbance measurements made at NIST is maintained.

Section 2 below describes the processes involved in qualifying a potential NTRM certifier. The second phase, continuous production, is described in Sections 3-4, dealing separately with the detailed specifications and construction of NTRM and SRM filters in Section 3, and the spectrophotometric certification and recertification process in Section 4. Finally, Section 5 is devoted to the subject of NIST traceability, detailing the conducting of comparison measurements between transfer spectrophotometers and the NIST ACD reference instrument, NIST access to certification data and control data, and blind testing.

## **2. CERTIFIER QUALIFICATION**

To be accredited under this program an NTRM certifier must fulfill the requirements found in NIST Handbooks 150<sup>4</sup> and 150-21.<sup>5</sup> In general, accredited certifiers must:

1. oversee the manufacture and certify the absorbance values of filter NTRMs;
2. be accredited by NVLAP as a certifier of filter NTRMs; and
3. have their technical proficiency as a certifier of filter NTRMs monitored and approved by NIST ACD.

Accreditation by NIST's National Voluntary Laboratory Accreditation Program (NVLAP<sup>®</sup>) is for the specific laboratory tasks of preparing and certifying NTRM neutral density glass filters. The NVLAP program will provide a structure for maintaining traceability to the regular transmittance scale maintained by the NIST ACD; while the ACD will provide the technical measurement services involved. Certifier qualification will be coordinated through the NVLAP program, with the technical participation of the ACD. The following sub-sections will treat the NVLAP/ACD coordination as well as



technical qualifications that will be required to achieve and maintain NVLAP accreditation for the preparation and certification of filter NTRMs.

## **2.1 Coordination with NVLAP**

The NIST *Handbook 150; Procedures and General Requirements*<sup>4</sup> (HB 150) contains the general description of the NVLAP program and the basic requirements for accreditation. Handbook 150-21<sup>5</sup> and NIST Special Publication 260-140 (this document), amplify HB 150 and contain specific technical requirements which must be met for accreditation.

NVLAP accreditation, and the required annual renewal of that accreditation, includes biennial onsite assessment of certifier facilities as well as proficiency testing. Technical issues peculiar to qualifying to produce neutral density glass spectrophotometric NTRM filters are discussed in the following paragraphs.

## **2.2 Facilities**

Filter NTRM certifiers will be responsible for maintaining all of the specifications described in Section 4 below, although some of the production and measurement needs may be sub-contracted to properly equipped and accredited vendors. At a minimum, the filter NTRM certifier will be expected to provide the actual value assignment of the certified transmittance and/or absorbance values. Spectrophotometric measurements must be carried out in a well ventilated, class 100,000 laboratory environment, to assure minimal surface contamination of reference filters and samples. The laboratory temperature must be controlled between 20 °C and 22 °C, and the relative humidity must not exceed 70 %. Provisions must be made to protect laboratory instruments and filter NTRMs from manipulation by unauthorized personnel.

### **2.2.1 Transfer Spectrophotometer**

A "Transfer Spectrophotometer" is a high quality, commercial or custom built spectrophotometer that has been "qualified" to maintain a "disseminated regular transmittance scale" relative to the national regular transmittance scale maintained by the reference spectrophotometer at NIST. Weekly measurements of NIST-certified Standard Reference Material (SRM) filters and annual comparison measurements with NIST assure the relationship of the disseminated scale to the national scale. A requirement for qualification to produce the full range of filter NTRMs is the ownership of at least one currently certified set of SRM 930 (nominal transmittances of 0.1, 0.2, and 0.3), one currently certified set of SRM 1930 (nominal transmittances of 0.01, 0.03 and 0.5), and one SRM 2034 holmium oxide wavelength standard.

A transfer spectrophotometer must, at a minimum, meet the specifications shown in Table 3, which also lists appropriate written standards or reference materials to test the

specifications. The values given are typical of modern, high resolution, scanning laboratory spectrophotometers. Testing the specifications of the candidate transfer spectrophotometer is a necessary part of the qualification process, and the NVLAP assessor will consider documentation of the instrument qualification process and results.

The instrument qualification process also includes the first of the annual comparisons with the NIST reference spectrophotometer. These comparisons constitute the "Direct Proficiency Testing" discussed in Handbook 150-21. The process is described in Section 5.5 below.

**Table 3**  
Minimal Specifications for Transfer Spectrophotometers

Specification	Value	Units	Reference Material	Written Standard
Wavelength Range	200 – 700	nm	NA	NA
Photometric Range	0 – 4.0	AU	NA	NA
Spectral Slit Width	0.5 – 2.0	nm	NA	ASTM E 958-93 (1993)[a]
Beam Convergence Cone Angle	< 6	degrees	NA	NA
Resolution	>1.5	None	Toluene in Hexane	USP[b], EP[c]
Wavelength Uncertainty	1	nm	SRM 2034	ASTM E 925-83 (1994)[d]
Wavelength Repeatability	0.1	nm	SRM 2034 or 656.1 nm D <sub>2</sub> line	ASTM E 275-93 (1993)[e]
Photometric Uncertainty	0.0022 0.005	AU AU	SRM 930-10 SRM 1930-1	ASTM E 925-83 (1994)
Photometric Repeatability	0.001 0.002	AU AU	SRM 930-10 SRM 1930-1	ASTM E 275-93 (1993)
Stray Light Ratio	<0.005 %	None	SRM 2032 @ 240 nm	ASTM E 925-83 (1994); ASTM E387-84 (1995)[f]
Stability	<0.0005	AU/h	NA	NA

NA = not applicable.

a. "Standard Practice for Measuring Practical Spectral Bandwidth of Ultraviolet-Visible Spectrophotometers," ASTM E 958-93 (1993), *Annual Book of ASTM Standards*, **03.06**, 786-790 (1997), West Conshohocken, PA.<sup>6</sup>

b. "Spectrophotometry and Light-Scattering," *United States Pharmacopoeia XXIII/National Formulary XVIII*, General Chapter **851**, 1830 (1996), The United States Pharmacopoeia Convention, Inc., Rockville, MD.<sup>7</sup>

c. "Absorption Spectrophotometry, Ultraviolet and Visible," *European Pharmacopoeia*, **2.2.25**, 28-29 (1997), Strasbourg, France.<sup>8</sup>

d. "Standard Practice for the Periodic Calibration of Narrow Band-Pass Spectrophotometers," ASTM E 925-83 (1994), *Annual Book of ASTM Standards*, **03.06**, 775-780 (1997), West Conshohocken, PA.<sup>9</sup>

e. "Standard Practice for Describing and Measuring Performance of Ultraviolet, Visible, and Near-Infrared Spectrophotometers," ASTM E 275-93 (1993), *Annual Book of ASTM Standards*, **03.06**, 708-718 (1997), West Conshohocken, PA.<sup>10</sup>

f. "Standard Test Method for Estimating Stray Radiant Power Ratio of Spectrophotometers by the Opaque Filter Method," ASTM E387-84 (1995), *Annual Book of ASTM Standards*, **03.06**, 740-749 (1997), West Conshohocken, PA.<sup>11</sup>

## 2.2.2 Means of Verifying Optical Specifications

SRM and NTRM optical filter CRMs are required to meet more rigorous optical specifications than routinely produced optical filters. Specifically, flatness, opposite face parallelism (optical wedge), and transmittance uniformity (optical homogeneity) are specifications that may require the individual testing of filters.

The *surface flatness* of SRM filters was originally specified as "two fringes of the Hg 546.1 nm line" and has more recently evolved to 1 wavelength of the 633 nm HeNe laser over the central 5 mm by 20 mm area of the filter. Since Fabry-Perot fringes occur at half-wavelength intervals, this is a minor adjustment representing the ascendancy of the laser over the traditional light source. Also, the restriction to the central area of the filter has been found to be both reasonable and practical, since the filters are smaller and thinner than most substrates ground to such flatness, and since the edges are most vulnerable to grinding error. NTRM certifiers may rely upon a supplier for ground and polished filters, with the instrumentation to verify the optical flatness of the filters residing with the supplier as well. Nevertheless, the certifier is responsible for the result, by assuring that the testing is done and the specifications are met.

The NIST ACD has tested for *opposite face parallelism (optical wedge)* for only the last two years, using a pair of autocollimators set up as a collimator/telescope pair.<sup>12</sup> A description for building such a device has also been described by the UV Spectrometry Group<sup>13</sup> of the United Kingdom. (A single autocollimator may be used for highly transmitting filters ( $T > 20\%$ ), but the reflection from the second surface is rapidly lost for more absorbing filters.) Although it would be advantageous for NTRM certifiers to have in-house capability for measuring optical wedge, it may be sufficient to control wedge mechanically in the production process. NTRM certifiers will not be required to have instrumentation for measuring opposite face parallelism, so long as they or their supplier(s) can assure parallelism through optical or mechanical means. ACD will test for

parallelism on the NTRM filters for the initial approval process (see Section 2.3 below), and will monitor samples from production lots of NTRMs against specifications.

The experience of the ACD is that parallelism is readily achieved with double-sided grinding apparatus, but not with the older single-sided methods. In the double-sided methodology, the parallelism may be checked and assured with periodic measurements over a lever arm of tens of centimeters, giving more than adequate control at the 0.1 mrad level. However, with one-sided grinding, the hot wax used to secure the pieces to a base plate may lift the piece unevenly by capillary action.

*Transmittance uniformity* testing involves spectrophotometric measurement at least at two positions on the filter, as described in Section 4.1.1. Therefore, the transfer instrument may be used, or a separate spectrophotometer not qualified as a transfer instrument may be used. The certifier must specify the equipment to be used.

### **2.3 Prototype Batch**

As a part of the NVLAP accreditation process, the certifier will prepare a prototype batch, following the methodology described in Sections 3 and 4 below on production and certification. The size of the batch is left to the certifier's discretion, with a minimum of five sets. Once the candidate transfer spectrophotometer has been qualified, initial transmittance density measurements are to be made on all filters of the batch. A sample of at least five sets is then to be sent to NIST, along with all transmittance density data, for testing and possible comparative measurements. These tests will form an integral part of the NVLAP assessment, but the results will not be made public.

The prototype batch may be used as the initial production batch, pending NVLAP accreditation, completion of aging, and successful testing for temporal drift (see Section 4.3 below on aging and drift testing).

### **2.4 Assignment of Uncertainties**

The NVLAP accreditation certificate will include an assignment of uncertainties approved by the NIST Statistical Engineering Division (SED), working with the certifier and the ACD. The major contributions to the total uncertainty will be "Type B" [determined by non-statistical means] components that are well known through the SRM optical filters program. The certifier will submit estimates of Type A [determined by statistical means] uncertainty components.

The estimation of Type A uncertainties requires replicate measurements under the conditions to be used for certification. The certifier is to acquire data with at least 30 degrees of freedom (acquired over several days) for each nominal transmittance (absorbance) level and each certification wavelength of the proposed NTRM. In addition to using the same time constants, gain settings, etc., as proposed for certification, the sample handling sequence must also follow the certification process.

For each nominal transmittance and wavelength, the number of degrees of freedom is given by

$$\nu = (n_{rep} - 1) \times n_f \times n_d$$

where  $\nu$  is the number of degrees of freedom,  $n_{rep}$  is the number of replicate measurements made on each day,  $n_f$  is the number of sets used (or filters at each of the nominal transmittances), and  $n_d$  is the number of days on which replicate measurements are made. Thus, 36 degrees of freedom are obtained for the five replicate measurements on three filters at each level for each of three days.

Data from different filters of the same nominal transmittance and data taken on different days may be pooled to yield a single uncertainty. At the same time, analysis of variance may be employed to determine whether a "day effect" exists (i.e., whether the measurement is statistically distinguishable from one day to another).

## 2.5 Rights and Terms of Accreditation

The certificate of accreditation indicates not only successful completion of laboratory assessment, but also that performance evaluation and NIST traceability have been demonstrated to the satisfaction of the ACD. The certificate permits the recipient to prepare, certify, and recertify filter NTRMs under the conditions set forth in this document. The certificate will specify the approved nominal absorbance levels, certification wavelengths, and uncertainties for filters to be produced as NTRMs.

NVLAP accreditation is subject to on-going proficiency testing, annual renewal, and a biennial onsite audit.

## 3. PRODUCTION OF SPECTROPHOTOMETRIC NTRMS

The functional component of a neutral density glass spectrophotometric NTRM is a small glass filter doped in the melt with chemical species such that the sum of their natural spectra yield a net spectrum which is nominally neutral, or wavelength independent (although containing many shallow local maxima and minima). Each NTRM filter glass is supported by a metal filter holder whose exterior dimensions are the same as those of the common 10-mm pathlength glass and fused-silica cuvettes used in UV/visible spectrophotometry. The cuvette-style holder is equipped with shutters, to protect the glass element when the filter is not in use. Several optical filters, having different transmittance levels, are grouped together to form a set. The filter set is stored in a container appropriate for shipping and between-use storage.

### 3.1 Filter Glass

The original study of neutral density glasses for use as visible absorption reference materials is described in NIST SP 260-116.<sup>14</sup> The family of glasses chosen by both NBS/NIST and by the National Physical Laboratory (NPL) in the UK<sup>15</sup> are members of the "NG" series of glasses manufactured by Schott Glass of Mainz, Germany.\* The glasses are designated as "NG-X", where "X" is a single- or double-digit number. The glasses in the series have congruent spectra.

#### 3.1.1 Optical Specifications

Table 4 shows the optical specifications common to all of the solid neutral density glass filters (SRMs 930, 1930, and 2030). While the dimensions may be modified to suit variations in the design of the filter holder, this document contains the specifications and mechanical drawings for the certifier to produce exact duplicates of the SRMs, if so desired. A chamfer has been included on all SRM filters, so that the filter may be removed for cleaning and replaced in the original orientation. The chamfer is unnecessary if the filter is otherwise marked for identification and/or orientation.

Specifications unique to the nominal transmittance level are given in Table 5. The tolerances listed for nominal transmittance are new to the SRM filters program and represent a contribution of the NTRM workshops to the quality of the SRM filters. Filters are now ground to a nominal transmittance rather than being ground to a target thickness. This change reflects the fact that a given glass type may vary enough from melt-to-melt that grinding to a target thickness results in an uncomfortably large variation in the nominal transmittance. NBS/NIST had not addressed the problem earlier because the actual transmittance was certified, making the nominal transmittance largely irrelevant. However, the NTRM/SRM program will be both technically and aesthetically strengthened by reasonable tolerances on the nominal transmittance levels.

Grinding to nominal transmittance involves making a test filter from a new melt or block of glass, determining the internal absorbance per unit length for the glass, and computing the appropriate thickness to attain the desired nominal transmittance. The tolerance range for nominal transmittance in Table 5 is based on a thickness tolerance of  $\pm 0.05$  mm. Thus, once the target thickness is measured for a given block of glass and nominal

---

\* To describe experimental procedures adequately, it is occasionally necessary to identify commercial products by manufacturer's name or label. In no instance does such identification imply endorsement by the National Institute of Standards and Technology, nor does it imply that the particular products or equipment are necessarily the best available for that purpose.

transmittance filter, grinding filters to the target thickness  $\pm 0.05$  mm will result in filters within the nominal transmittance tolerance.

**Table 4**  
Optical Specifications Common to All Neutral Density Glass SRM Filters

Item	Specification
Width <sup>a</sup>	10.4 mm $\pm$ 0.2 mm
Height <sup>a</sup>	30.3 mm $\pm$ 0.2 mm
Chamfer <sup>b</sup>	2 mm $\times$ 2 mm $\times$ 45°, one corner
Flatness	$< 1\lambda$ (633 nm) over central 5-mm $\times$ 20-mm clear aperture
Parallelism	$\leq 0.1$ mrad
Quality	Scratch/dig (MIL-O-13830A) 80/50, no visible inclusions or straiæ, Standard bubble/inclusion class 2

<sup>a</sup>Optional. The certifier may choose other dimensions consistent with the flatness specification below, and with the size constraints of the filter holder.

<sup>b</sup>Used to orient the filter, so that it may be cleaned and remounted in the same orientation. If the filter is otherwise marked, a chamfer may be unnecessary.

**Table 5**  
Neutral Density Glass SRM Optical Specifications Unique to  
Transmittance Level at 546 nm

TD <sub>nom</sub> <sup>1</sup>	T <sub>nom</sub> / % <sup>2</sup>	Range of T/ % <sup>3</sup>	Glass <sup>4</sup>	t <sub>nom</sub> /mm <sup>5</sup>
2.0 <sup>6</sup>	1	0.88 – 1.12	NG-3	2.0
1.5 <sup>6</sup>	3	2.64 – 3.36	NG-3	1.5
1.0 <sup>7</sup>	10	9.3 – 10.7	NG-4	1.9
0.7 <sup>7</sup>	20	18.6 – 21.4	NG-4	1.3
0.5 <sup>7,8</sup>	30	29.1 – 30.9	NG-5	1.9
0.3 <sup>6</sup>	50	49 – 51	NG-11	2.3

<sup>1</sup>Nominal transmittance density, or absorbance referred to air, at 546.1 nm.

<sup>2</sup>Nominal transmittance referred to air at 546.1 nm.

<sup>3</sup>Permissible range for the certified transmittance at 546.1 nm, based on an uncertainty of 0.05 mm in thickness. The range is computed as 12 % relative for NG-3 glass, 7% relative for NG-4 glass, 3 % relative for NG-5 glass, and 1.6 % relative for NG-11.

<sup>4</sup>Designation of glass made by Schott Glass.

<sup>5</sup>Nominal thickness in mm for the filter, as calculated from Schott catalog values for the internal absorbance per unit thickness. The actual thickness required to achieve the specified transmittance tolerance may vary from block to block of glass material.

<sup>6</sup>One of three filters included in the set for SRM 1930.

<sup>7</sup>One of three filters included in the set for SRM 930.

<sup>8</sup>The only filter included in SRM 2030.

### 3.1.2 Rejection of Out-of-Specification Materials

Verification measurements for the flatness and parallelism specifications were discussed earlier, in Section 2.2.2. Verification of these specifications is ultimately the responsibility of the NTRM certifier, but may be performed by adequately equipped and qualified supplier(s). The NTRM certifier must maintain records of the equipment and methods used by external suppliers of ground and polished filters. Filters not meeting the specification for flatness or parallelism must be rejected. The tolerance range for nominal transmittance is to be checked with the earliest spectrophotometric measurements made on a given filter; out-of-tolerance filters again must be rejected.

### 3.2 Filter Holders

Figure 1 shows an assembled SRM 930 filter with the two shutters partially open, along with front and back views of two filter holders, a shutter, a retaining clip and screw, and a glass filter. Machine drawings for all of the component parts of the filter holder are given in Appendix B. The default optical tolerances on the reduced machine drawings are given in a separate table in Appendix B. Full size drawings are available from NIST upon request. Each optical filter consists of a glass filter, a filter holder, a retaining clip and screw, and two black Delrin shutters. The shutters, retained by beveled grooves in the filter holder, are completely removed from the filter for use and are replaced for storage.

For many years, the NBS/NIST optical filter SRM holders were machined from 0.5-inch square profile bar stock, to an exterior dimension determined by the stock. The holders are now machined from plate stock by a numerically controlled (NC) mill, and the nominal exterior dimension has been reduced to 12.5 mm in agreement with the common exterior dimensions of modern spectrophotometric cuvettes. Some of the older filters fail to fit into modern instrument filter holders. The holder and retaining clip are black anodized aluminum.

The same filter holder design is used for all neutral density glass filters of SRM 930, SRM 1930, and SRM 2030, as well as for the metal-on-fused silica filters of SRM 2031. The retaining clip is compatible with filter thickness from 1.3 mm to 3 mm. Individual filters are distinguished by engraving, as discussed below.





National Institute of Standards & Technology

# Certificate

## Standard Reference Material<sup>®</sup> 930e

### Glass Filters for Spectrophotometry

This Standard Reference Material (SRM) is a primary transfer standard certified using a national reference spectrophotometer at NIST [1-3]. It is intended for use in the verification of the scale and absorbance scales of spectrophotometers in the visible spectral region. SRM 930e is a set of three individual glass neutral density filters in separate metal holders and three empty filter holders. The exposed surface of the glass is approximately 12.5 x 8 mm, measured from a point 0.5 mm above the top edge of the filter holder (see Figure 1). The filter glass is provided with a number that provides the glass filter identification for use. Each retaining holder bears a retention number for the set and the individual filter (10, 20, or 50). The values correspond to the nominal percent transmittance (100 x transmission) of each filter. SRM 930e differs from the prior series, SRM 930d, only in that it is subject to tightened optical polishing tolerances (see Instrumentation and Use Warning).

**Certified Values of Transmittance and Transmittance Density.** Certified transmittance values independently determined for each filter at 21 ± 1 °C and at five wavelengths in the visible region of the electromagnetic spectrum are given in Table 1. Certified transmittance density values are given in Table 2, as calculated from the certified transmittances  $T$  as  $-\log_{10} T$ . These values should be indicated on the absorbance (A) scale of the spectrophotometer if the filters are measured against air. The relative uncertainties for the certified transmittance values of Table 1 are indicated in Table 3a, in relative percent. The transmittance uncertainty for a particular value in Table 1 is obtained by multiplying the transmittance value by the relative percent uncertainty (from Table 3a), and dividing by 100. The relative uncertainties for the transmittance density values of Table 2 are given in the same relative percent in Table 3b. The uncertainties for the transmittance density values given anticipate possible errors due to surface contamination and fundamental materials effects. Spectral irradiance values are indicated in parentheses beneath the wavelengths of certification in Tables 1 and 2. The wavelength values for which the certified values are valid.

Figure 1. SRM 930 component parts, showing a side view of a filter holder with partially open shutters, front and back views of an empty filter holder, filter glass, retaining spring and screw, and shutter.

### 3.3 Set Containers

NIST optical filter SRMs are shipped in cylindrical canisters with screw-top lids, machined from solid aluminum and anodized. Four cylindrical holes machined into the solid canister serve as storage positions for the three filters and single empty filter holder (blank) that comes with each set of SRM 930 or SRM 1930. Four beryllium-copper springs are used to secure the holders into the four positions for shipping and should be retained for transporting the filters for recertification. Machine drawings for the canisters, lids, and shipping springs are given in Appendix C for four-position canisters. NIST canisters for the single filter and blank holder of SRM 2030 have only two holes drilled and two shipping springs per set. The aluminum is prepared free of machining oil to reduce the potential for filter contamination.

Although they are not airtight, the metal canisters provide a rugged container for shipping, and reasonable protection from contamination of the filter surfaces. The all-metal construction is intended to reduce the electrostatic attraction of dust particles to the surface of the filters. NTRM certifiers may adopt the NIST design for shipping and storage canisters, but are not constrained to use this design.

NTRM certifiers must avoid the use of packaging materials that will deteriorate with time, and could contaminate the filters by outgassing or producing particulate matter.

### 3.4 Identification Marking

Upon admission to the NTRM program, each *certifier* will be issued a unique code to designate its filters. This code will be two or three alphanumeric characters. Each *filter type* will further be identified by a five-position (maximum) alphanumeric character field. Each *filter set* will be identified by a unique five-position (maximum) alphanumeric serial code. Within each set, *individual filters* will be encoded with two digits representing the nominal percent transmittance.

<u>Cert.</u> <u>Code</u>	<u>Filter</u> <u>Type</u>	<u>Set</u> <u>S/N</u>	<u>Nom</u> <u>% T</u>	
<i>xxx</i>	<i>yyyyy</i>	<i>zzzzz</i>	<i>##</i>	
SRM	930e	124	30	NIST example
SD	VISF	AF334	30	Super-Duper Filter Co. example

The outside of the set container must be indelibly marked with at least the manufacturer's code and filter type. Other information such as the NTRM name, the set serial code, the manufacturer's name, and the NTRM logo may also be present. Neither the NIST logo nor the NVLAP logo may be displayed here. NIST SRMs have the NIST logo, the SRM number (filter type), and SRM name engraved on the canister lid—the set number (serial code) is not marked on the canister.

Each filter holder is to be engraved on one side near the top with the set serial code (set number) and the nominal transmittance (%) and on the other side with the manufacturer's code and filter type. No marks are to be made on the top side of the filter holder. (NIST is reserving this space for a future barcode to provide filter tracking during the certification process.) Engraving is to be done before the filter is mounted in its holder.

This encoding scheme will allow each filter and its associated data to be uniquely identified and tracked. NIST is also preparing to mark each piece of glass used in the filters near its top with a unique serial number. This will permit better data handling, preparation tracking, and inventory control. It will permit positive identification of the glass used to replace damaged glass in SRM sets. Furthermore, it can be used in lieu of the chamfer as an orientation mark. NTRM certifiers may also wish to serialize their filter glasses.

### **3.5 Assembly of Sets**

At NIST, numbered sets of SRM filters are assembled before any of the spectrophotometric measurements are made. This protocol provides identification and accurate data logging since the filter holders are uniquely identified, but the glass is not currently being serialized. Uniformity testing and drift testing, described in Section 4 below, may result in the need to replace individual filters in a set, or to an entire set being held back from circulation until a single filter meets the drift rate specification. Certifiers may find it advantageous to serialize the glass and use temporary holders for preliminary measurements. Sets could then be assembled from qualified filters just prior to the final certification measurements. The NIST procedure for assembling sets from freshly prepared filter glass and holder parts is described below.

All fully prepared filter glass and holder components must be thoroughly cleaned and air-dried before assembly. This is especially important for the glass filters, as particulate matter may be left behind from the polishing rouge used. Filters are to be rinsed with an appropriate solvent to remove grinding and polishing materials. Holder parts will have been cleaned of machine oil before anodizing, but must be carefully examined for loose contaminants after anodizing, and any buffing or polishing materials must be fully removed.

Filters must be assembled on a clean surface with good lighting. The filter glass is to be handled by the edges and with powder-free gloves. Vigorous wiping with lint-free lens tissue is to be used to clean the filter, after first blowing off loose dust with a manual air-bulb. Care must be taken to avoid transferring body oil to the filter via the lens tissue – parts of the tissue that have been in contact with skin must not contact the glass. (Tissue should be used and discarded liberally!) Before mounting, the filter is to be examined under bright, uniform light to check for residual surface dirt and smears or defects in the glass itself.

The filter is to be carefully placed into the proper side of the holder using plastic forceps or plastic-tipped tweezers to avoid scratching or smudging the filter. The retaining clip is then to be attached with the black plastic screw and the shutters slid into place. The filters constituting a given set are placed in the set container, along with an empty (and not engraved) filter holder to be used for blank measurements.

#### **4. CERTIFICATION AND RECERTIFICATION OF NTRMS**

The spectrophotometric measurements that lead to certification are virtually identical to those for recertification of filter sets which are returned at the end of their certification period, although some differences may be identified in the overall processes. The subsections below will concentrate on the certification process, following the filter cleaning and assembly discussed above. Subsection 4.5 is devoted to the differences between the recertification process and the certification process.

##### **4.1 Rejection and Replacement of Filter Materials**

Filters will be rejected on the basis of excessive optical wedge (lack of sufficient parallelism), inadequate flatness, low optical quality, and poor transmittance uniformity. The rejection criteria for the first three of these were given in Table 4 and Section 3.1.1, and instrumentation and tests for flatness and parallelism were described in Section 2.2.2. The "Optical Quality" specifications of Table 4 are somewhat subjective, but are familiar to sufficiently experienced optical technicians, and are judged simply by visual inspection.

Two additional acceptance criteria – based on spectrophotometric measurements – are given in Table 6 and described below. Transmittance uniformity and transmittance drift represent known properties of neutral density glass filters that are included in the uncertainty statement and in the acceptance criteria for filters. That is, a certain level of non-uniformity and a certain amount of drift are considered to be inevitable in filters and are accounted for in the uncertainty evaluation. However, filters are also individually examined for each of these properties to eliminate filters in the tails of the distribution. Testing of the uniformity property is described below. Testing of the drift property will be covered in Section 4.3 on the aging of filters.

###### **4.1.1 Uniformity Testing**

The transmittance uniformity of optical filters used as transfer standards is important because the certifying instrument and the instrument under test may project different sizes and shapes of incident light onto the filter at different positions on the filter.<sup>16</sup> The spectrophotometer used for uniformity testing must be capable of measuring the transmittance density of the filter at the center of the filter, which is nominally 15 mm above the base of the filter. The second measurement is then made by raising the filter 7 mm in the beam, so that the light is incident at a point nominally 8 mm above the base of

the filter. The absolute value of the difference of these two absorbance readings, at 546.1 nm, must be equal to or less than the tolerance given in Table 6 to accept a given filter. (An effective method of displaying the absorbance difference on the instrument is to define one of the two readings as a "blank" and the other as a "sample." The absorbance then displayed is in fact the absorbance difference between the two positions.)

**Table 6**  
Rejection Limits for Transmittance Uniformity and Drift

$T_{\text{nom}}/\%$	$A_{\text{nom}}$	$\delta_u^a$	$\delta_d^b$
1	2	0.0045	0.0025
3	1.5	0.0040	0.0025
10	1	0.0015	0.0015
20	0.7	0.0015	0.0015
30	0.5	0.0015	0.0015
50	0.3	0.0010	0.0015

<sup>a</sup> Permissible absorbance difference for two positions on a filter, separated by 7 mm.

<sup>b</sup> Permissible absorbance drift for a six-month aging period.

To avoid "false positive" rejections, for which the filter is sufficiently uniform but random uncertainty in the two readings results in a difference exceeding the rejection criterion, the random uncertainty must be accommodated. Filters that "fail" the uniformity test by a margin of less than 0.0005 AU may be tested four additional times and re-evaluated on the basis of the average of the five results. To minimize the random uncertainty, the measurement may be made at an arbitrarily large – but consistent – spectral slit width (SSW). It may be advisable to employ the largest SSW available for sufficient precision for low transmittance samples.

## 4.2 Spectrophotometric Certification Measurements

The transfer spectrophotometer used for certification measurements has been described in Table 3 and the qualification process for the spectrophotometer in Section 2.2.1. The qualification process is to determine the optimal instrumental settings and measurement protocol to be used for certification. The following sub-sections discuss the protocol for a single spectrophotometric measurement, including environmental and warm-up conditions, instrumental parameters fixed by the certification requirements, and instrumental parameters and sequencing that are to be optimized for particular instruments.

A logbook must be kept near each operational transfer spectrophotometer, in which to record temperatures, humidities, and times at which the instrument is turned on and off, as noted in the paragraphs below.

#### 4.2.1 Environmental Control

For many years, the neutral density glass SRM filters have been certified at a laboratory temperature of  $21\text{ }^{\circ}\text{C} \pm 1\text{ }^{\circ}\text{C}$ , and the accompanying certificate has approved their use over a temperature range of  $21\text{ }^{\circ}\text{C} \pm 2\text{ }^{\circ}\text{C}$ . It is obviously necessary that NTRM filters be certified within the temperature range of  $21\text{ }^{\circ}\text{C} \pm 1\text{ }^{\circ}\text{C}$  for ready comparison of measurements with NIST. Temperature control and monitoring of the sample may be especially important for commercial instruments with compact sample compartments. It is therefore necessary that certifiers monitor and/or control the temperature of their transfer spectrophotometer sample chamber to ensure that measurements are made at the proper temperature.

Humidity has not been tightly controlled in the ACD laboratory containing the reference spectrophotometer. The relative humidity of the laboratory has varied between approximately 30 % and 65 % over the last two years. The most constant humidity performance has been during air conditioning season, when the relative humidity rarely strays more than two or three percentage points from 45 %. NTRM certifiers are to have at least a simple humidity measurement device in the spectrophotometric measurement laboratory, and record the reading daily. Even better, a calibrated electronic hygrometer could be used to record the humidity automatically with each instrumental run.

Temperature and humidity readings (and the date and time of day) are to be entered into the instrument logbook at least twice per operational day – once when the instrument is turned on for warm-up and once when the instrument is turned off.

#### 4.2.2 Certification Wavelengths and Bandwidths

The five wavelengths chosen as certification positions for the neutral density glass SRMs and NTRMs were selected to give a reasonably comprehensive coverage of the visible spectrum with a manageable amount of data. The wavelengths were also chosen to correspond to local maxima and minima in the gently undulating spectra, as may be seen in Figure 2. (Coincidentally, the only extremum wavelength specified to the nearest tenth of a nm, 546.1 nm, is that of the widely used atomic mercury green line.) The use of a local extremum, or position of zero slope, reduces the effect of wavelength calibration errors on the accuracy of the measured transmittance density. Certificates for neutral density glass NTRMs will require that the wavelength scale of the user's instrument have an uncertainty of less than 1 nm.

A minor problem caused by the spectral undulations and certification at local extrema is that large instrumental bandwidths will affect the apparent absorbance. Thus, maximum permissible bandwidths have been established for these reference materials, as shown in

Figure 2 and listed in Table 7. These bandwidths are determined by a combination of the local curvature (second derivative) at each position and the uncertainty component included for bandwidth effects.

Thus, the maximum permissible bandwidth could be increased at the expense of expanding the uncertainties. Computing correction coefficients for larger bandwidths and including a table of such coefficients on the certificate could also increase it. Such changes may be taken into consideration later in the NTRM program, since many modern utility instruments operate at large fixed bandwidths.

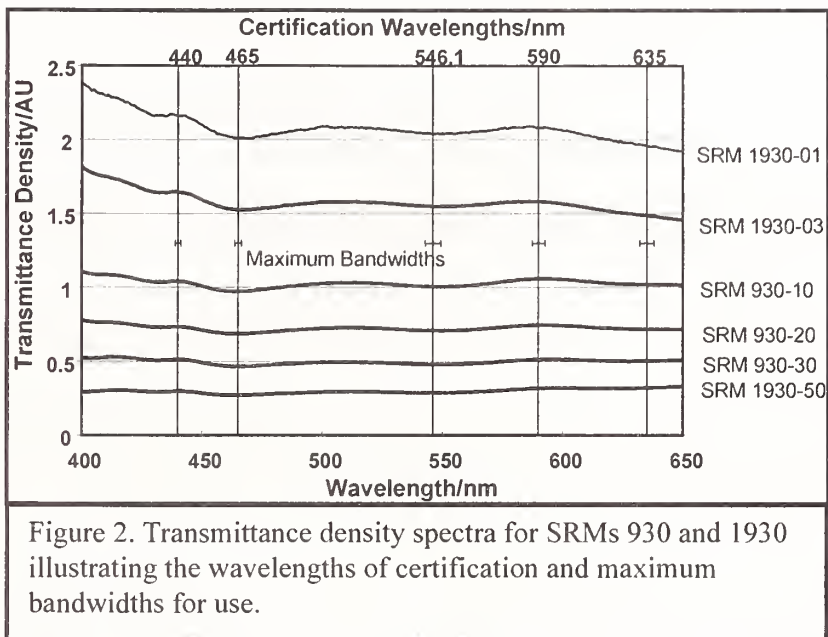

**Table 7**  
Certification Wavelengths and Permissible Spectral Slit Widths

Wavelength/nm	440	465	546.1	590	635
SSW/nm	2.2	2.7	6.5	5.4	6.0

#### 4.2.3 Instrumental Parameters and Measurement Protocol

The most critical element in certifying reference filters is the optimal and consistent operation of reference and transfer spectrophotometers. The qualification process described in 2.2.1 will be used to establish the optimal instrumental parameters and measurement protocol that will be used for a single "measurement." In particular, a certification measurement may well be more time consuming than the recommendations for a "typical" measurement by the manufacturer of the instrument. Table 8 lists some instrumental operation recommendations that are explored further in the following paragraphs. All uncertainties imply a "coverage factor" or "expansion factor" of two, which would correspond to a 95 % confidence interval for >30 degrees of freedom.

*Wavelength Accuracy.* The use of local extrema for certification wavelengths gives a certain leeway in the need for wavelength accuracy, but most of that leeway should be allotted to the end user's spectrophotometer, not the certifier's. The certifier must thus

reduce wavelength uncertainty to 0.1 nm or less. This target uncertainty may be more stringent than the instrument manufacturer will routinely support and thus requires diligent calibration and verification by the NTRM certifier.

**Table 8**  
Instrumental Operation Recommendations

Property	Recommendation
Wavelength Uncertainty	0.1 nm
Warm-up Time	1 hour typical
Data Acquisition Time	Resulting in $\leq 0.0003$ AU repeatability at 1 AU
Replication	$\geq 3$ x
Gain	Invariant for each T, $\lambda$ ; see text
Spectral Slit Width	1 nm
Single-beam Equivalence	Daily correction data; see text

Figure 3 illustrates the calibration of the wavelength scale of the original reference spectrophotometer in the ACD. The "bias" plotted on the ordinate is the difference in the wavelength reading on the instrument dial at the peak of a given atomic line and the accepted wavelength of the line. (Atomic line position uncertainties are sufficiently small as to be negligible for the present purposes.) Thus, the instrument may be seen to read high by slightly more than 0.1 nm at 440 nm. Since we set the instrument to the nearest 0.1 nm for all certification measurements, the instrument will be set to a wavelength reading of 440.1 nm for certification at 440 nm, until such time as the calibration is shown to change. Similarly, 590 nm certification is performed at an indicated setting of 590.2 nm, and so forth. Many instruments are capable of using one or both of the well-known visible lines from the system deuterium lamp (used as the UV continuum source) for re-calibration, using built-in software. Some systems may accommodate the use of atomic pen lamps for wavelength calibration.

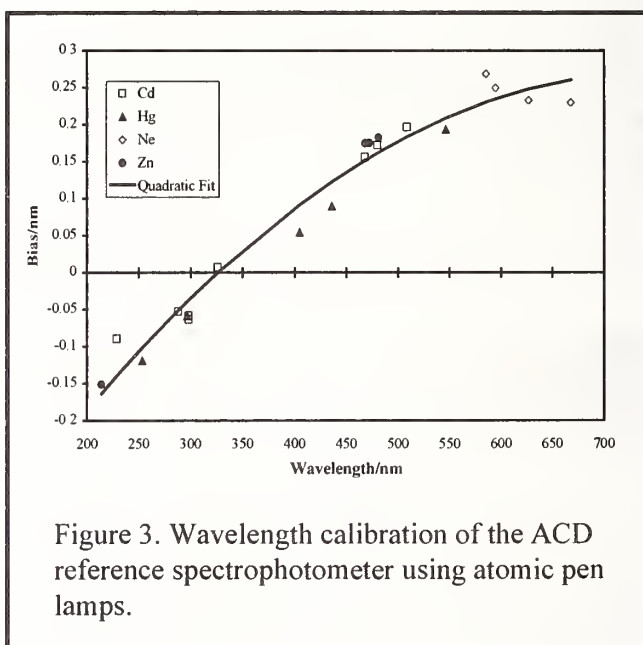

Figure 3. Wavelength calibration of the ACD reference spectrophotometer using atomic pen lamps.

Atomic lines are the most highly recommended means of wavelength calibration, but SRM 2034 is available for the calibration of instruments for which atomic sources cannot be readily used. Regardless of the calibration method, full spectral scans of SRM 2034



must be acquired and saved on a monthly basis as documentation of wavelength accuracy for NVLAP assessment. The certified wavelength uncertainty of SRM 2034 is 0.1 nm for each of 14 certified band positions. The certified band positions of SRM 2034 are shown in Table 9, and the spectrum is shown in Figure 4.

**Table 9.**

Certified Wavelengths (nm) of Minimum Transmittance of 14 Bands for SRM 2034 at Six Spectral Slit Widths

SRM 2034 Band No.	Spectral Slit Width/nm*					
	0.1	0.25	0.5	1	2	3
1	240.99	240.97	241.01	241.13	241.08	240.90
2	249.83	249.78	249.79	249.87	249.98	249.92
3	278.15	278.14	278.13	278.10	278.03	278.03
4	287.01	287.00	287.01	287.18	287.47	287.47
5	333.47	333.44	333.43	333.44	333.40	333.32
6	345.55	345.55	345.52	345.47	345.49	345.49
7	361.36	361.35	361.33	361.31	361.16	361.04
8	385.45	385.42	385.50	385.66	385.86	386.01
9	416.07	416.07	416.09	416.28	416.62	416.84
10	-----	-----	-----	451.30	451.30	451.24
11	467.82	467.82	467.80	467.83	467.94	468.07
12	485.28	485.28	485.27	485.29	485.33	485.21
13	536.54	536.53	536.54	536.64	536.97	537.19
14	640.51	640.49	640.49	640.52	640.84	641.05

\*Certificate expanded uncertainty for all positions is  $\pm 0.1$  nm.

*Warm-up Time.* During the process of instrument qualification, data will be taken to observe temporal effects in the returned measurement values and their repeatability during the first hour or so after the instrument is turned on. Traditionally, such effects are mostly attributed to stabilization of the system lamps and the detector, especially for photomultiplier detectors. A minimum stabilization time will be established for the system as a whole, as well as for the lamp(s) and/or detector, if they are separately controlled. For the ACD reference spectrophotometer, a stabilization time of one hour is required for the system electronics (including the high voltage to the PMT) and either of the two system lamps.

The date, time, and action must be recorded in the instrument logbook each time the instrument (or individually controlled component) is turned on and off.

*Data Acquisition Time.* A transfer spectrophotometer will acquire and store data digitally. Although a single digital reading requires only milliseconds, the result displayed as "a reading" may represent an average of many digital readings taken of an analog voltage appropriately time-filtered for the digital sampling rate. The operator is typically presented with a variety of possible data acquisition times from which to choose in the operation of the instrument. During instrument qualification, replicate data are to be acquired to characterize the absorbance repeatability (e.g., the standard deviation of ten replicate measurements) of the instrument as a function of the acquisition time parameter, for a 1-AU filter. This data may be acquired at all five certification wavelengths, or at the certification wavelength for which the repeatability is the poorest for a given data acquisition time. This data may then be used to establish the instrumental acquisition time parameter for certification measurements, in accord with Table 8. That is, an acquisition time may be identified for which the standard deviation of ten measurements is less than 0.0003 AU.

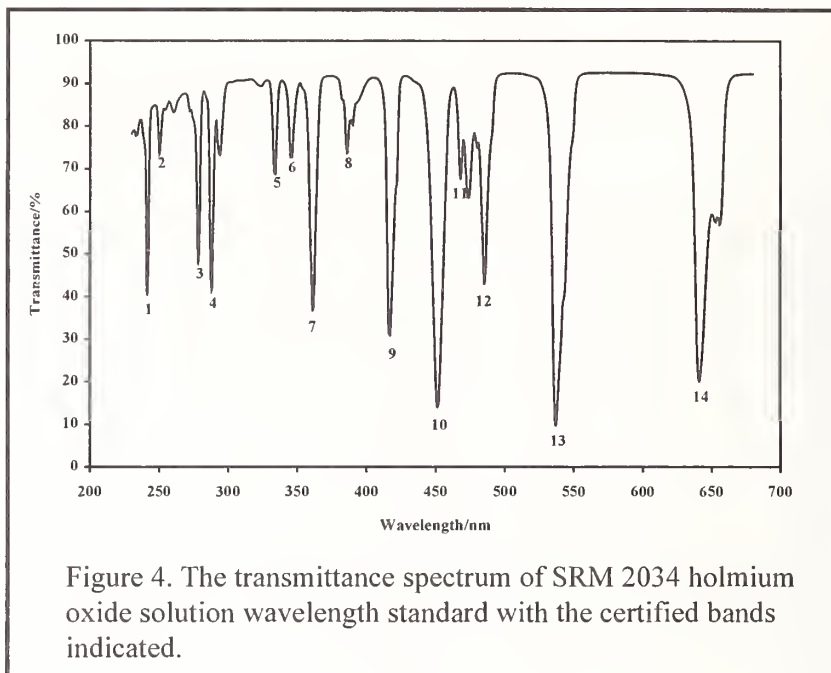

Figure 4. The transmittance spectrum of SRM 2034 holmium oxide solution wavelength standard with the certified bands indicated.

The single acquisition time parameter established on the basis of the above measurements at 1 AU may be used for all wavelengths and for all transmittance values from 0 AU to 2 AU. However, it is also acceptable for the certifier to employ longer acquisition times for transmittance densities above 1 AU. The experimental data and acquisition time choice(s) for certification measurements must be clearly documented in the qualification report.

The total effective signal averaging time for the certification measurement is given by the acquisition time per reading multiplied by the number of readings taken (for a given filter at a given wavelength) in a certification measurement, as discussed below.

*Measurement Sequence/Replication.* Each replicate reading involving cycling of the samples or the grating consumes extra time for the mechanical motion and introduces wear to the instrument mechanical systems. The number of such replicates is therefore kept low, and is not used for "Type A" uncertainty evaluation on a filter-to-filter basis. For a double-beam transfer instrument, it is acceptable for replication to be direct – without cycling of the samples or grating – if the instrument software permits. A minimum of three replicate readings is required in either event, though more could be used for direct replication without excessive use of time.

The measurement sequence within an instrumental "run" must be clearly stated in the measurement protocol, and used for all certification measurements. The sequence is the description of the order in which replicate measurements are made at multiple wavelengths for multiple filters (if an automated sample transport is used in the instrument).

The data file(s) generated by the instrument may require post-processing to produce the averages of the replicate measurements in the format for database entry. The certifier must maintain the intermediate data, complete with replicate measurements, for at least one year. Such data files are considered to be "run files", which can be examined for "outlier" values or instrument problems when questions arise about certification data. The final measurement for a given filter and wavelength is the mean of the replicate readings. The standard deviation of the mean of the replicate readings is to be computed and compared to the expected repeatability as a quality check on the measurement.

*Instrumental Gain.* Any instrumental gain settings are to be chosen to minimize the noise contribution of the electronics to the final measurements. As with all other instrumental parameters used for certification, gain settings must be consistent throughout each accreditation year, at minimum. Reference beam attenuation methods available for dynamic range extension are not recommended for the range of the NTRM filters, and should be used for the lower transmittance filters only after consultation with ACD.

*Spectral Slit Width.* Transfer spectrophotometers are to be operated at an instrumental SSW of 1 nm or less for optimal agreement with the NIST reference instrument (operated at a SSW of 0.8 nm). For bandwidths less than 1 nm, the bandwidth dependence of the measured absorbance is negligible. Smaller spectral slit widths might be desirable to limit the light on the photocathode of the detector and improve the linearity of the photomultiplier tube. Once an operating bandwidth is chosen for certification measurements, it must be used consistently, at least through a given accreditation year.

*Single-Beam Equivalence.* For a double-beam spectrophotometer, the baseline transmittance may be defined as

$$T_B = I_{o1} / I_{o2}$$

where  $I_{O1}$  is the radiant flux of beam 1 and  $I_{O2}$  is the radiant flux of beam 2 (with no attenuation in either beam). If an arbitrary sample of true transmittance (with respect to

air)  $T$  is placed in the sample position and transmits a radiant flux  $I_{S1}$ , then we may show that

$$T = \frac{I_{S1}}{I_{o1}} = \frac{(I_{S1}/I_{o2})}{(I_{o1}/I_{o2})} = \frac{T'}{T_B}$$

where  $T'$  may be seen to be the possibly inaccurate double-beam measurement of the transmittance of the sample. Thus, the true value of transmittance is given by dividing the measured value at each wavelength by the baseline transmittance at the same wavelength. The equivalent treatment in absorbance is to subtract the baseline absorbance from the double-beam absorbance, due to the logarithmic relationship of the two measures.

Transmittance and absorbance "baseline" spectra are shown in Figure 5 for a commercial double-beam spectrophotometer used for utility work in the ACD. The baseline spectrum

is simply a scan over the desired spectral region with no sample or blank in either beam. For perfectly balanced beams, the transmittance should be within the measurement repeatability of 100 % at every wavelength and the absorbance should be within the measurement repeatability of zero at every wavelength. The observed departure from perfect balance may be attributed to a number of factors including small differences in the reflecting surfaces in the

two beams, and in the aging of these surfaces. The discontinuity at 380 nm, corresponding to a change of lamps, clearly reflects alignment differences between the tungsten and deuterium lamps.

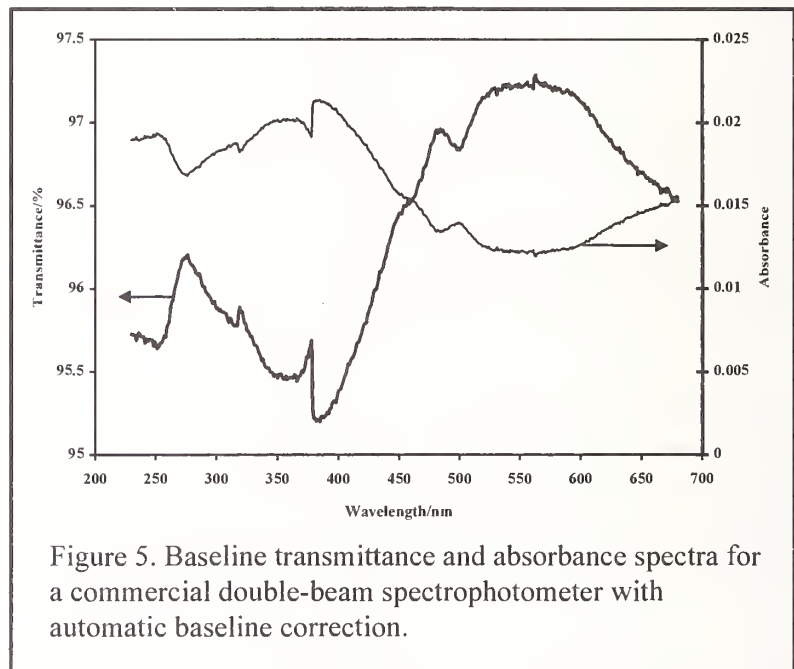

Figure 5. Baseline transmittance and absorbance spectra for a commercial double-beam spectrophotometer with automatic baseline correction.

Candidate transfer spectrophotometers will typically be double-beam instruments with the option of baseline correction to single-beam equivalence. This treatment combines the best features of single-beam and double-beam spectrophotometry, at the cost of some increase in noise. If automatic baseline correction is not available, the correction must still be included in the data reduction, using suitable baseline measurements. Baseline correction data must be acquired at the beginning of each day of data acquisition, and may be acquired more frequently. If the transfer spectrophotometer is a true single-beam

instrument, or operated in true single-beam fashion, reference readings must be made immediately before and after each sample reading.

#### 4.2.4 Measurement Data

The final measurement data – one measured transmittance and/or absorbance for each certification wavelength and each filter– must be saved in computer readable form and in hard copy. Data detailing intermediate measurements and calculations involved in the determination of each reported transmittance are to be saved either electronically or in hard copy. Such "run data" may be used to look for instrumental problems and possible measurement errors in a given set of data and are to be kept for a period of time equal to the certification period of the filter NTRM.

The final measurement data and run data must clearly contain the identity of the relevant filter(s), and the final measurement data must be imported into an appropriate database to log all valid measurements on all of the certifier's filter NTRMs. Data determined by the qualified operator to be invalid must not be imported into or retained in the database. The certifier's quality system is to specify remedial action to be taken.

#### 4.2.5 Revision of Measurement Parameters or Protocols

No instrument parameter or protocol for the certification or recertification of filter NTRMs is to be changed within a given accreditation period without the prior approval of the ACD and NVLAP. The certifier may propose any desired changes in writing to ACD/NVLAP at the time of accreditation renewal. Routine transfer spectrophotometer maintenance and repairs (such as lamp changes) must be noted in the instrument log book. Alterations and repairs deemed significant must be reported to ACD/NVLAP and may require a complete re-qualification of the transfer instrument.

### 4.3 Aging Protocol

Neutral density glass filters are subject to a slow but sometimes significant temporal drift in the transmittance and/or absorbance. The predominant theories developed over the years attribute drift to two possible sources. The more fundamental source is thought to result from a reaction (such as oxidation, hydration, and/or dehydration) at the freshly ground surface of a new filter which reduces the reflection of light at the entry and exit faces of the filter, thereby increasing the transmittance with time.<sup>17</sup> The less fundamental source is attributable to surface contamination from the storage environment of the filter, leading to decreased transmittance with time. The more fundamental source is especially troublesome for newly created filters, giving rise to the need for an aging protocol. The surface contamination source is responsible for the need to continue recertifying filters annually, even after the surface chemistry has stabilized.

The protocol that has been used at NIST over the years, and seems to work reasonably well, requires a minimum aging period of six months for all filters and requires the drift

at all certified wavelengths for all filters of a set to be less than the value quoted in Table 6 over a six-month period. The measurement protocol is discussed below.

#### 4.3.1 Precertification Measurements

During the mandatory six-month aging process, periodic spectrophotometric measurements are made on the filters using the transfer spectrophotometer. These precertification measurements are to be permanently recorded to document the aging and stability acceptance of the filters. An electronic record of each measurement is to be entered into the master database discussed in 4.2.4, properly identified as a precertification or stability measurement.

The frequency of precertification measurements is left to the discretion of the certifier. The tradeoffs between measurement frequency and aging time are discussed in the following subsection. The certifier is not required to maintain a rigid measurement schedule, as long as the stability acceptance protocol is observed.

#### 4.3.2 Stability Approval and Certification

If a filter has been aged for six months, with spectrophotometric measurements at the beginning and the end of the period, the stability is considered to be acceptable if the absolute value of the change in absorbance at each certification wavelength is less than  $\delta_d$ , the drift limit specified in Table 6. Alternatively, if the drift criterion is exceeded at only one of the five wavelengths, the stability is acceptable if the average of the absolute values of absorbance change at the five wavelengths is less than the specification in Table 6.

The measurement database used at NIST has a comparison feature, permitting the comparison of any two selected data sets for a particular filter set. This feature is convenient for stability testing as well as for evaluating the performance of filter sets returned for recertification.

The frequency of precertification measurements determines the granularity of a six-month sliding window. As an example, precertification measurements at NIST are normally made at intervals of approximately two months. If a given filter fails to meet the stability criterion, the next time at which a six-month period can be examined is six months after the **second** precertification measurement. Thus, with the NIST protocol, a filter may fail the stability test after six months of aging but pass after eight months of aging, based upon the drift between the measurement at the two-month point and at the eight-month point.

At NIST, sets are assembled at the beginning of the aging process, and the failure of a single filter to satisfy the drift criterion results in holding the entire set until the next measurement is made. This approach may not be the most efficient use of materials, but

has been necessary to maintain the entire measurement history of each filter in the absence of identification markings on the filter glass itself.

The NTRM certifier must have a documented protocol for the aging of filters, including the precertification measurement intervals and the methodology for identifying and tracking filters and comparing measurements at six-month intervals.

#### **4.4 Certification Measurement**

Once the stability criterion has been satisfied, as described in Section 4.3, the material is qualified for the final certification measurement. Indeed, the final aging measurement may be used as the certification measurement.

However, since filter NTRMs are certified for a period of one year from the date of certification, the certifier may choose to stability-qualify filter sets and postpone the official certification measurement until the set is sold to an end-user. The end user then enjoys the full benefit of the certification period.

A permanent hard copy and computer-readable copy of the data acquired in the certification measurement must be maintained as long as the filter is in use. The electronic data must be imported into the database used to maintain the measurement history of all NTRM filters. The data must be uniquely identified as the original certification data for the filter set. In the NIST database, a "type" key identifies a precertification measurement as "type 1" and the original certification measurement as "type 2." Two other "types" are associated with recertification, as discussed below.

#### **4.5 Recertification**

Filter NTRMs are certified for a period of one year, permitting a smaller uncertainty estimate for stability than for SRMs, and yielding overall uncertainties that can be reasonably competitive with those for SRMs. Certifiers of filter NTRMs will maintain an active recertification program for the materials that they produce and will accompany each filter NTRM sold with adequate documentation of recertification procedures and scheduling considerations.

End users are not required to have their filter NTRMs recertified by the original certifier, but for the artifacts to retain their NTRM status, any recertifications must be done by a currently accredited filter NTRM certifier. Filters to be recertified as NTRMs must be NTRMs or SRMs. A producer may recertify other filters, but may not issue NTRM certificates for these. If an SRM is recertified by an NTRM certifier instead of by NIST, it becomes an NTRM until such time as it is recertified by NIST.

The certifier should maintain a set turn-around time, so that customers may meet recertification deadlines and not be deprived of the use of their reference materials for a prolonged period. The customer should be instructed to contact the certifier to schedule

recertification before sending filters. In times of excessive backlog, customers may then retain their filters for use until notified by the certifier to ship them for recertification.

The NTRM certifier must maintain a recertification log, documenting customer contacts, the arrival of filters for recertification, the location and status of filters in-house for recertification, and the shipment of filters to their owners.

The recertification process involves two measurements on the filter set using the transfer spectrophotometer and the full certification protocol as described in Section 4.2. The first measurement is made on the filter set in "as received" condition, and the measurement data are imported into the filter history database and classified as a measurement "type" known as "as received" (designated as "type 3" at NIST).

The filters in the set are then disassembled and cleaned one at a time (to assure that filters are not interchanged among holders) using lint-free lens tissue and the same procedures as described for the original assembly in Section 3.5. After cleaning, each filter is carefully re-assembled, using the chamfer or identification mark on the filter to assure that the orientation of the filter in the holder is the same as it was originally.

After cleaning, a second spectrophotometric measurement is made, and the results are imported into the filter history database as a "type" of measurement denoting "recertification" (designated as "type 4" at NIST). The results are also incorporated into a new certificate to accompany the filter set and supersede the previously certified values.

The "as received" data are also to be sent to the end user, in an auxiliary report to the new certificate. NIST has found that many end users need documentation of the discontinuous change made in the filter transmittance by the cleaning and also need to re-evaluate the accuracy of data taken on instruments being tested using the filters shortly before recertification.

The certifier must compare the results of both types of measurements on the returned filters to the previous year's certified values and note any "out-of-tolerance" results in the end user report and in a record to be reviewed by the certifier and NVLAP during the annual reassessment of assigned uncertainties. For this purpose, an "out-of-tolerance" result is one for which the difference between the prior certification result and the measurement in question exceeds the expanded uncertainty associated with the certification.

Table 10 gives several of the more common outcomes of tolerance checking and the interpretation that may be conveyed to the customer. For other types of results, the certifier is to consult with the ACD technical advisor to the filter NTRM program. If the filter set has not been recertified within the recommended interval, the customer is to be advised to observe the schedule more rigorously in the future. If the drift and the cleaning result indicate an alarming rate of surface contamination, the customer is to be advised to store and use the filters in a cleaner environment. If the drift of a cleaned and relatively



"young" filter indicates more rapid surface chemistry effects than accommodated by the uncertainty estimate, the customer is to be advised to have the set recertified ahead of schedule until the filter stabilizes.

**Table 10**  
Out-of-tolerance Interpretations for Filter Recertifications

As-received <sup>1</sup>	Recert. <sup>1</sup>	Time <sup>2</sup>	Interpretation <sup>3</sup>
>	~	>	Mature filter; too much contamination; customer advised to observe schedule.
>	~	≤	Contaminated mature filter; customer advised to store in cleaner environment.
~ or >	<	>	Immature filter with or without contamination; customer advised to observe schedule.
~	<	≤	Immature filter with or without contamination; customer advised to recertify early.

<sup>1</sup>For "As-Received" and "Recertification" data: > means that one or more measured absorbance exceeds the previously certified value by more than the expanded uncertainty; < means that one or more absorbance is low and out of tolerance; and ~ means that the measurement is in tolerance.

<sup>2</sup>Time between prior certification and recertification: > implies more than one year; and ≤ implies one year or less.

<sup>3</sup>A "mature" filter is one for which the surface chemistry has stabilized, and is generally more than one or two years old; drift in absorbance is normally positive with time; cleaning reveals observable decrease in absorbance. An "immature" filter is still showing a negative absorbance drift with time after cleaning and is typically less than two years old.

#### 4.6 Documentation

Most of the relevant documentation issues associated with the certification process are covered in the companion documents Handbook 150 and Handbook 150-21. The most critical element of concern from the technical point of view is that the measurement history of a given filter be maintained as long as the filter is in service. Adequate redundancy would include hardcopy of all certification and recertification measurements, computer files of all such measurements, and frequent back-up of all computer files. Additional necessary documentation would include the logbook for each transfer spectrophotometer and the logbook(s) for tracking production filters and recertification filters.

One full set of certification and recertification data will be forwarded to and maintained at NIST. Certifiers will use electronic submission of data to NIST in a format specified by the ACD and given in Subsection 5.7.

## **5. TRACEABILITY TO NIST**

### **5.1 The Traceability Chain**

Transmittance is a ratiometric measurement and hence is not ultimately traceable to any of the seven fundamental SI units. Over the past three decades many of the National Measurement Institutes (NMIs) worldwide – including NIST – have constructed reference (or "high accuracy") spectrophotometers of closely related design. These instruments are said to maintain the scale of regular transmittance for the nation. In the US, two such instruments have been maintained; one in the Analytical Chemistry Division and one in the Optical Technology Division (OTD). The "division of labor" at NIST has been that Standard Reference Materials for use in chemical spectrophotometry are certified and recertified in the ACD, and all other applications of regular transmittance are handled in the OTD.

The multiplicity of scales becomes moot to the extent that frequent comparisons among the NMIs and between the NIST instruments shows the scales to be indistinguishable. Indeed, comparison is one of the few ways to validate the accuracy of such instruments. Although such comparisons have been infrequent to date, the current interest in international comparability and equivalence should cause an increase in frequency.

Stable absorbing reference materials are routinely used by NMIs to validate the accuracy of commercial spectrophotometers. Specifically, the concept of a "transfer spectrophotometer" as introduced in Section 2.2.1 has been employed within NMI laboratories to leverage the measurement capability of the reference instrument. The transmittance scale maintained by a transfer spectrophotometer is referred to as a "disseminated transmittance" scale.

The traceability of disseminated transmittance measurements to the national regular transmittance scale is assured by regular comparison of the transfer instrument and the reference instrument, using stable reference materials. This process is described in the following paragraphs.

### **5.2 NIST SRMs**

The certifier must own a minimum of one set of SRM neutral density glass filters, covering the nominal transmittances of the NTRM filters to be produced. The most general coverage of approved nominal transmittances would be one set each of SRM 930 and SRM 1930. A somewhat preferable model would be to own two sets of each needed SRM, with appropriately interleaved recertification schedule. In addition, the certifier

must own at least one NIST holmium oxide solution wavelength standard, SRM 2034, which is certified for ten years and is not recertifiable.

The purchase of SRMs from NIST is no different for NTRM certifiers than for any other NIST customer. SRMs may be purchased through the NIST Standard Reference Materials Program.<sup>2</sup>

SRMs are normally certified for two years, but the filter NTRM traceability protocol requires that the active-use SRMs have been recertified by NIST within **one** year. This protocol may be observed by having the filters recertified at one-year intervals, but the traceability chain will be broken for part of the time the filters are away from the certifier. Therefore, it is recommended that the certifier own **two** sets of SRMs, and have them recertified alternately. The most recently certified set becomes the active reference set.

To obtain recertification of SRMs by NIST, contact ACD at 301-975-4115. Typical recertification turnaround time is three to four weeks for most months of the year. August and September usually have longer turnaround times owing to vacations and the end of the Government fiscal year.

### 5.2.1 Storage and Measurement Frequency

At least one set of SRMs representing transmittance levels being certified by the certifier must be measured weekly (during periods of certification activity) on the transfer spectrophotometer using the certification protocol. This regular measurement represents the primary link between the transfer spectrophotometer and the ACD reference spectrophotometer. The weekly measurement period represents a compromise between keeping the filters closed up and protected in their container and having regular comparison with NIST. The SRMs used for this purpose will have been recertified by NIST within one year.

All measurements of these absorbance SRMs must be archived in both hard-copy and electronic form. It may be advantageous to keep the data in the same database as the production data, but identified as yet a fifth "type" of measurement ("control"). Otherwise, control data may be held in a separate database or archive file.

Recommendations for the storage and handling of NIST SRMs are given on the certificates. The fundamental idea is that the SRMs are to be stored in their containers in a clean environment between uses and must be handled so as to avoid contaminating the measurement surfaces, especially with fingerprints and dust.

In case of inadvertent contamination of the surface(s) of a neutral density glass filter with substances other than dust, the set must be returned to NIST for cleaning and recertification. This rather rigid policy regarding the cleaning of filters reflects the NIST experience that cleaning is an inexact science – at best – and must be accompanied by recertification for reliable results.

Clean air is to be used to blow dust from the surface of all filters, before they are loaded into the instrument. The only reliable dusters we have found have been rubber bulb blowers operated by hand. Pressurized, aerosol can dusters sold by optical companies are found to deposit a film that changes the measured transmittance of SRMs and must be avoided.

### 5.2.2 Wavelength Calibration

Wavelength calibration with atomic lines and/or with SRM 2034 was discussed in Section 4.2.3. For purposes of traceability, full spectral scans of SRM 2034 must be acquired and saved at least monthly.

## 5.3 NTRM Certifier Standards

At least one full set of NTRM filters examined and measured by NIST as a part of the original accreditation program is to be reserved by the certifier for use as local "Certifier Standards." These filters must be measured at the same time as the weekly SRM measurements (Section 5.2.1) and also are to be measured on every day of active NTRM certification or recertification measurements. These filters will represent the daily control samples used to chart instrument performance between SRM measurements.

Certifier standards are to be assigned a "certified value" for each level and wavelength, just as for other filters. They must be cleaned and recertified at least once a year by the certifier, with appropriate annotation of control charts and notebooks. These working standards may be cleaned and recertified more frequently if required to maintain the control chart.

The frequent control measurements of the certifier standards must be kept in electronic form, from which hard copy charts may be generated, as discussed in Section 5.4. The data may be kept in the same mode as selected for SRM filter data and discussed in 5.2.1. This would be as either a "control" type of measurement in the production database or in a separate control database or archive file.

## 5.4 Control Charts

Although it is impractical to intercompare the transfer and reference instruments frequently, it is relatively straightforward to document the consistent performance of the transfer instrument between comparisons. This is done by means of utilizing the NTRM certifier standards as daily control samples and the NIST SRMs as weekly control samples.

The spectrophotometric certification of NTRM filters is a nearly ideal application of the technique of control charting an instrument and may be implemented in a variety of ways ranging from totally manual to totally automated. The process at NIST is semi-

automated, with control measurements automatically appended to a cumulative control data file each time the instrument is run, and the data plotted in Excel with some manual intervention. Figure 6 shows an example for the ACD reference spectrophotometer, using a nominal 10 % transmitting SRM 930 filter at 546.1 nm.

The essence of operation is for the operator of the transfer spectrophotometer to know if the instrument is "in control" on each operational day. Otherwise, it is possible for several days worth of data to be invalidated by an instrument drifting out of control unnoticed. At the simplest level, the operator can verify that the instrument is in control by comparing the present measurements on the control filters with ranges defined as acceptable for these filters. The acceptable ranges are given by 95 % confidence intervals about the mean value for each filter for a large number of prior measurements. If a measurement lies outside of the 95 % confidence interval, but within a 99 % confidence interval, the instrument is not deemed to be out of control unless the behavior is repeated on successive measurements.

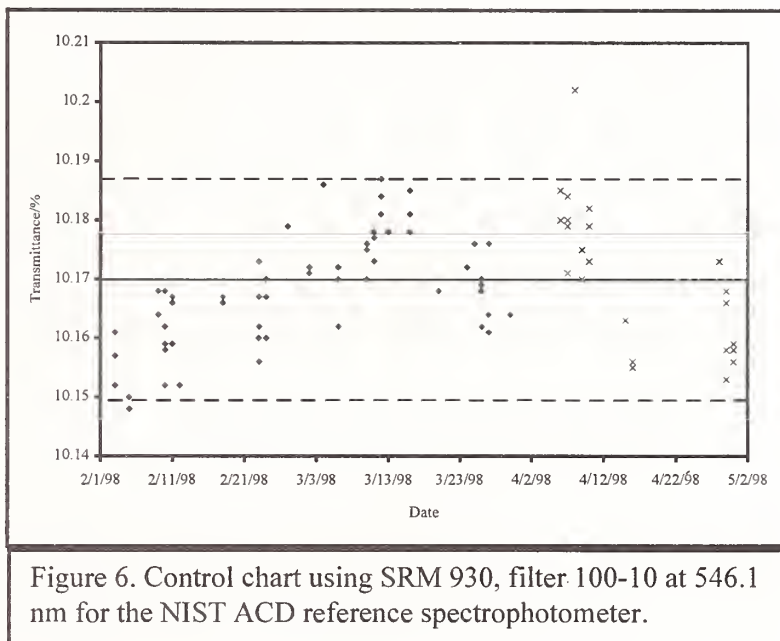

Figure 6. Control chart using SRM 930, filter 100-10 at 546.1 nm for the NIST ACD reference spectrophotometer.

If the instrument is judged to be out of control, certification and recertification measurements must be suspended until the source of the problem is found, corrected, and documented.

The exact methodology of control charting is left to the discretion of the certifier but must yield charts that facilitate NVLAP assessment. At the very least, control data must be archived in computer-readable form for control charting and/or review. An illustrative semi-automated model would be as follows.

A hard-copy control chart for a single certification wavelength – such as shown in Figure 6 – could be generated for each nominal transmittance level once a month. (This process could be synchronized with the monthly SRM 2034 run, for instance. See Section 5.2.2.) The abscissa would represent a sliding three-month period of time, including the prior two months and the coming month. The data for the prior two months would be shown, and used to compute 95 % confidence control intervals. The chart would show the computed mean for the two-month period and the 95 % control interval. The chart should also show the certified value for the given filter and wavelength.

The control charts for each transmittance level would be kept in a fixed location close to the reference instrument, and the control data for each new day could be plotted by hand on the control charts. At the end of the month, fresh charts would be prepared using the archived data, with room left for plotting the next month's data.

Control charts are to also be updated weekly for the SRM absorbance data, which is acquired weekly (Section 5.2.1). The control limits for each level and wavelength are to be given by the certified value and the expanded uncertainty. NIST statisticians may use such data to recommend bias corrections for transfer spectrophotometers.

### **5.5 Annual Comparison of Transmittance Scales**

The NIST ACD will conduct annual comparison measurements with each NTRM certifier, under the "Direct Proficiency Testing" provision of Handbook 150-21 (Sec. 285.22b2i). The ACD will send certified reference filters to the certifier, without revealing the measured values. The certifier will measure the filters and return the filters and measurement results to NIST. The filters are measured once more at NIST, to assure closure on the measurement, and a report is prepared for the certifier and the NVLAP assessment.

### **5.6 Lot Samples and Blind Testing by NIST**

The certifier is directed by the "Indirect Proficiency Testing" provision of Handbook 150-21 (Sec. 285.22b2ii) to submit a portion of each lot of filters produced to the NIST ACD for testing. Since optical filter production is neither entirely a batch process nor a continuous process, the exact number of sets required will be negotiated at the time of the testing. These sets are to be accompanied by hard copy and/or electronic measurement data. These samples will be subject to comparison measurements at the discretion of the NIST ACD.

The NIST ACD also reserves the right to conduct blind testing on NTRM filters through the use of third party intermediaries.

### **5.7 Reporting Measurement Data to NIST**

To permit NIST to carry out its oversight of the NTRM certification process, certifiers shall transmit certification, recertification, calibration, and other measurement results to NIST ACD in a prescribed electronic format. NIST will maintain the data from the filter NTRM program in a secure database. Initially, the data will be available only to NIST personnel charged with producer performance monitoring; however, it is our intention to grant access eventually to selected portions of the database to NTRM producers so that they can monitor their own filters. This access will be based upon the manufacturer's code identification of the filter. ACD will use the database to "control chart" the performance of producers, their filters, and their transfer spectrometers, to assist in

determining uncertainties of NTRM certification measurements, etc. NVLAP examiners will have access to this database and will review a producer's past performance in the course of renewing its accreditation. The existence of and access to the NIST NTRM database does not relieve producers of their own internal record keeping requirements as described elsewhere in this document.

It is NIST ACD's intention to make this data reporting requirement as painless as possible for NTRM producers to meet. The details of the data reporting scheme are still being worked out, and the data and metadata required to be reported, the structure of the report, and the mechanism for reporting are still under development at NIST. The following subsections are offered to suggest the scope and possible mechanisms for this data reporting and should be considered preliminary and subject to change. NIST ACD expects to work with the initial NTRM producers to develop the final data reporting procedures. We expect that the reporting format and mechanism, once established, will be the same for all producers.

#### 5.7.1 Data to be Reported

The data reported to NIST shall include only the final measurement data for each measurement made on a given filter set, as described in section 4.2.4. The producer is required to maintain the "run data" as prescribed in section 4.2.4, but this should not be transmitted to NIST under the general data reporting requirement. If irregularities are noted in the final measurement data, NIST may request that run data be submitted as a part of a trouble shooting and diagnostic process with the producer.

The following final measurement data must be reported to NIST ACD:

- Certification Measurement Data
- Precertification Measurement Data made during the filter aging process
- Recertification Measurement Data including the "As Received" and Recertified Measurement Data
- Calibration/Control Measurement Data including the weekly control data from NIST SRMs and the daily control data from the producer's "in house" standards
- Annual Comparison Measurement Data

#### 5.7.2 Metadata to be Reported with Each Data Record

Measurement data by itself is not useful unless it is accompanied by ancillary information relating to the measurement process. We refer to such ancillary data as metadata (data about data). Table 11 lists such metadata along with format and field requirements.

**Table 11**  
Metadata to be Reported with Each Data Record

Item	Datatype [Max Field Size]	Format	Example
Filter Identification mfg. code,filter type,set s/n,nom %T,glass s/n	character [3],character [5],character [5],integer [2],character[10]	xxx,yyyyy,zzzz,##,qq qqqqqqqq	SRM,2030a,123,30,NG 50123
Date & Time	integer [12]	YYYYMMDDHHMM	199809101123
Operator	character [15]		P. DeRose
Sample Temperature, °C	float [2.1]	xx.x	22.1
Relative Humidity, %	integer [2]	xx	45
Measurement Type Code	character [1]		R
Spectrometer Model No.	character [15]		NIST ACD HAS-II
Spectrometer S/N	character [15]		00001
Reference Sample	character [15]		air
Sample Position	integer [2]		04
Effective Integration time, s	integer [2]		3
Spectral Slitwidth, nm	float [2.3]	xx.xxx	1.13
Replicates	integer [2]		5
Measurement Mode	character [25]		single-beam; sphere
Spectrometer Qualification	integer [12]	YYYYMMDDHHMM	199802141555
Transmittance Proficiency	integer [12]	YYYYMMDDHHMM	199808111045
[Linearity Calibration]*	integer [12]	YYYYMMDDHHMM	199808111402
Wavelength Calibration	integer [12]	YYYYMMDDHHMM	199808121623
Wavelength Bias File	character [12]	xxxxxxxx.yyy	98wave.tbl
[Transmittance Linearity Bias File]**	character [12]	xxxxxxxx.yyy	98trans.tbl

\*Double-aperture test date, if double-aperture device is supported and used.

\*\*Transmittance bias correction curve, if measured by double-aperture device or assigned by NIST to correct measured bias.

### 5.7.3 Structure of a Data Record

The metadata is prefixed to the measurement data as shown in Figure 7. Datafields are delimited with carriage return (OD<sub>H</sub>) and linefeed (OA<sub>H</sub>) characters (CR/LF). Subfields within a datafield are delimited with comma (2C<sub>H</sub>) characters. A measurement datafield consists of a nominal wavelength value, followed by a comma (2C<sub>H</sub>) delimiter and then a transmittance value. The structure and format of the measurement datafields can be used for isolated wavelength/transmittance value pairs as shown in Figure 7, as well as for a complete spectrum where wavelengths occur at the incremental wavelength interval used to record the spectrum. Multiple data records may exist within a data file.

### 5.7.4 Frequency of Reporting Data to NIST

To ensure that NIST ACD can fulfill its oversight role, producers must transmit the required data to NIST in a timely manner. However, the frequency of reporting will depend on the number of filters being produced and recertified by the producer, among



other things. Accordingly, the reporting frequency will be negotiated individually with each NTRM producer during the accreditation procedure and will remain constant through the year, unless irregularities arise that necessitate a change.

#### 5.7.5 Mechanism for Reporting Data to NIST

To facilitate the data reporting to NIST, ACD will set up an Internet web site to permit electronic transmission of the data files. The site will be password-protected and accessible through the NIST firewall. The reception mechanism will check the data upon receipt and will return an appropriate acknowledgment message to the producer.

#### 5.8 Accreditation Review

The accreditation renewal process provides an opportunity for fine tuning the mechanisms for maintaining traceability. The review process by the certifier and NVLAP assessor, with assistance as needed from the NIST ACD and SED, may well result in modifications to the proficiency testing protocols, certification protocols, and certification uncertainties.

SRM,2030a,123,30,NG50123<sub>CR/LF</sub>  
199809101123<sub>CR/LF</sub>  
P. DeRose<sub>CR/LF</sub>  
22.1<sub>CR/LF</sub>  
45<sub>CR/LF</sub>  
R<sub>CR/LF</sub>  
NIST ACD HAS-II<sub>CR/LF</sub>  
00001<sub>CR/LF</sub>  
air<sub>CR/LF</sub>  
985<sub>CR/LF</sub>  
1E-09<sub>CR/LF</sub>  
04<sub>CR/LF</sub>  
3<sub>CR/LF</sub>  
1.13<sub>CR/LF</sub>  
5<sub>CR/LF</sub>  
single-beam, I-sphere<sub>CR/LF</sub>  
199802141555<sub>CR/LF</sub>  
199808111045<sub>CR/LF</sub>  
199808111402<sub>CR/LF</sub>  
199808121623<sub>CR/LF</sub>  
98wave.tbl<sub>CR/LF</sub>  
98trans.tbl<sub>CR/LF</sub>  
440,29.15 <sub>CR/LF</sub>  
465,32.27 <sub>CR/LF</sub>  
546.1,30.74 <sub>CR/LF</sub>  
590,27.69 <sub>CR/LF</sub>  
635,27.78 <sub>CR/LF</sub>

Figure 7. Example of a data record.

## 6. FEES AND REVIEW OF FEE STRUCTURE

The fees for NVLAP accreditation are covered elsewhere. These fees support the general ISO-25 quality assessment process, including the cost of the biennial assessments and annual renewal. In addition, the NIST/ACD will need to recover the costs associated with the various comparison measurements associated with the program. For the initial year of the program, ACD will evaluate a payment system based upon the rate schedule used for the recertification of SRM filters. SRM 930 filters are currently recertified for \$700 and SRM 1930 filters will be recertified for the same cost as SRM 930 on the new reference spectrophotometer. Each NTRM certifier will purchase the equivalent of four recertifications per year from the ACD, broken down as follows:

- Recertification of SRM set; payable at the time of recertification.
- Direct proficiency test; payable near the anniversary of accreditation.

- Indirect proficiency test – one per year on submitted samples unless problems are encountered; payable at the time of the test.
- Equivalent of one certification fee for the examination of all lot samples submitted to ACD for optical examination and testing; payable upon receipt of ACD report, near the anniversary of accreditation.

It should be noted that the cost can vary by a factor of two, depending on the extent of NTRM filters offered by the certifier, i.e., whether the range of the filters offered covers that of both SRMs or just SRM 930. In the above list, the direct and indirect proficiency tests involve the same number of measurements (two complete measurements) as a recertification. At the present time, we have no data to compare the costs of examining lot sample filters with that of performing recertifications, nor do we have sufficient information to assess the costs of the quality assurance monitoring of the NTRM data. It is the intent of ACD to automate this process to minimize the expense, but the operation of the filters NTRM program must become cost neutral to ACD after the initial year. Accordingly, it will be necessary to re-assess the ACD charges as the program matures.

## References

- <sup>1</sup> Franklin R. Guenther, William D. Dorko, Walter R. Miller, and George C. Rhoderick, The NIST Traceable Reference Material Program for Gas Standards, NIST Spec. Pub. 260-126, U.S. Government Printing Office, Washington, D.C., 1996.
- <sup>2</sup> National Institute of Standards and Technology, Standard Reference Materials Program, Room 204, Building 202, Gaithersburg, MD 20899-0001; Tel: (301) 975-6776; Fax: (301) 948-3730; e-mail: SRMINFO@enh.nist.gov.
- <sup>3</sup> R. Mavrodineanu, "An Accurate Spectrophotometer for Measuring the Transmittance of Solid and Liquid Materials", *J. Res. NBS* **76A**, pp. 405-425 (1972).
- <sup>4</sup> NVLAP Procedures and General Requirements, NIST Handbook 150, U.S. Government Printing Office, Washington, D.C. (1994).
- <sup>5</sup> G.W. Kramer, J.C. Travis, C.D. Faison, and S.D. Rasberry, Chemical Calibration, Certifiers of Spectrophotometric NTRMs, NIST Handbook 150-21, U.S. Government Printing Office, Washington, D.C. (1999).
- <sup>6</sup> "Standard Practice for Measuring Practical Spectral Bandwidth of Ultraviolet-Visible Spectrophotometers," ASTM E 958-93 (1993), *Annual Book of ASTM Standards*, **03.06**, 786-790 (1997), West Conshohocken, PA.
- <sup>7</sup> "Spectrophotometry and Light-Scattering," *United States Pharmacopoeia XXIII/National Formulary XVIII*, General Chapter 851, 1830 (1996), The United States Pharmacopoeia Convention, Inc., Rockville, MD.
- <sup>8</sup> "Absorption Spectrophotometry, Ultraviolet and Visible," *European Pharmacopoeia*, 2.2.25, 28-29 (1997), Strasbourg, France.
- <sup>9</sup> "Standard Practice for the Periodic Calibration of Narrow Band-Pass Spectrophotometers," ASTM E 925-83 (1994), *Annual Book of ASTM Standards*, **03.06**, 775-780 (1997), West Conshohocken, PA.
- <sup>10</sup> "Standard Practice for Describing and Measuring Performance of Ultraviolet, Visible, and Near-Infrared Spectrophotometers," ASTM E 275-93 (1993), *Annual Book of ASTM Standards*, **03.06**, 708-718 (1997), West Conshohocken, PA.
- <sup>11</sup> "Standard Test Method for Estimating Stray Radiant Power Ratio of Spectrophotometers by the Opaque Filter Method," ASTM E387-84 (1995), *Annual Book of ASTM Standards*, **03.06**, 740-749 (1997), West Conshohocken, PA.
- <sup>12</sup> J.C. Travis, M.V. Smith, and G. W. Kramer, "Optical Wedge Effects in Instruments and Standards for Molecular Absorption Spectrophotometry", *Appl. Spectrosc.* **52**, 1414 (1998).

<sup>13</sup> C. Burgess and A. Knowles, Standards in Absorption Spectrometry, (Chapman and Hall, London, 1981), pp. 128-9. The recent revision of this book, though not containing the particular information cited, is nevertheless worth consulting: C. Burgess and T. Frost, Standards and Best Practice in Absorption Spectrometry, (Blackwell Science Ltd., Oxford, 1999).

<sup>14</sup> R. Mavrodineanu, R. W. Burke, J.R. Baldwin, M.V. Smith, J.D. Messman, J.C. Travis, and J.C. Colbert, Standard Reference Materials: Glass Filters as a Standard Reference Material for Spectrophotometry – Selection, Preparation, Certification, and Use of SRM 930 and SRM 1930, NIST Special Publication 260-116, (U.S. Government Printing Office, Washington, 1994).

<sup>15</sup> J.F. Verrill, in Advances in Standards & Methodology in Spectrophotometry, eds. C. Burgess and K.D. Mielenz, Elsevier, Amsterdam, 1987, 111-124.

<sup>16</sup> J.C. Travis, N.K. Winchester, and M.V. Smith, "Determination of the Transmittance Uniformity of Optical Filter Standard Reference Materials," *J. Res. NIST* **100**, 241 (1995).

<sup>17</sup> Reference 6, p. 46.

## **APPENDIX A. WORKSHOPS ON NIST TRACEABILITY IN CHEMICAL SPECTROPHOTOMETRY**

Three workshops were held to assist in the design of the filters NTRM program. The "NIST Highlight" report of the original workshop is reprinted below.

### **Workshop Sets the Stage for NIST Traceable Reference Material (NTRM™) Optical Filters**

A "Workshop on NIST Traceability in Chemical Spectrophotometry" on September 11, 1997, attracted 32 participants from pharmaceutical and chemical companies, instrument and optical component manufacturers, government regulators, and NIST. The focus of the program was to establish a recognized traceability link to the CSTL national reference spectrophotometer through commercially produced reference materials for chemical spectrophotometry. The demand for such reference materials has been accelerated by the increase in both regulatory and voluntary quality control measures, exceeding NIST production capacity. The consensus of the workshop was that leveraging of the NIST measurement capability into the commercial sector was both feasible and desirable, as long as comparable quality and adequate traceability are assured and regulatory agencies accept the standards. The primary outcome of the gathering was to endorse the concept of NTRM standards for chemical spectrophotometry and to call for two additional meetings for final implementation.

**Contact: J. C. Travis (x-4117) or G.W. Kramer (x-4132)**



## APPENDIX B. DESIGN OF HOLDERS FOR OPTICAL FILTERS SRMS.

Figures B1-B4 are the machine drawings for the NIST filter holders. Figure B1 is the general assembly diagram, as an edge-on cross section showing the retaining clip holding the filter into place. Three views of the holder body are shown in Figure B2, with the top left view showing the holder body viewed from the side where the filter is to be mounted. We refer to this as the "back" of the filter, or the side that faces away from the light source when mounted in a spectrophotometer. The bottom left view of Figure B2 is of one of the plain sides of the filter. NIST engraves the filter set number and nominal transmittance (%) near the top of the filter on the side shown. The orientation of the NIST reference spectrophotometer and all of our commercial spectrophotometers is such that the filter is in the proper orientation if the thumb of a right-handed operator is covering the engraving as the filter is inserted into the sample chamber of the instrument. In other words, the beam of all of our instruments is incident from the left-hand side of an operator facing the instrument sample chamber.

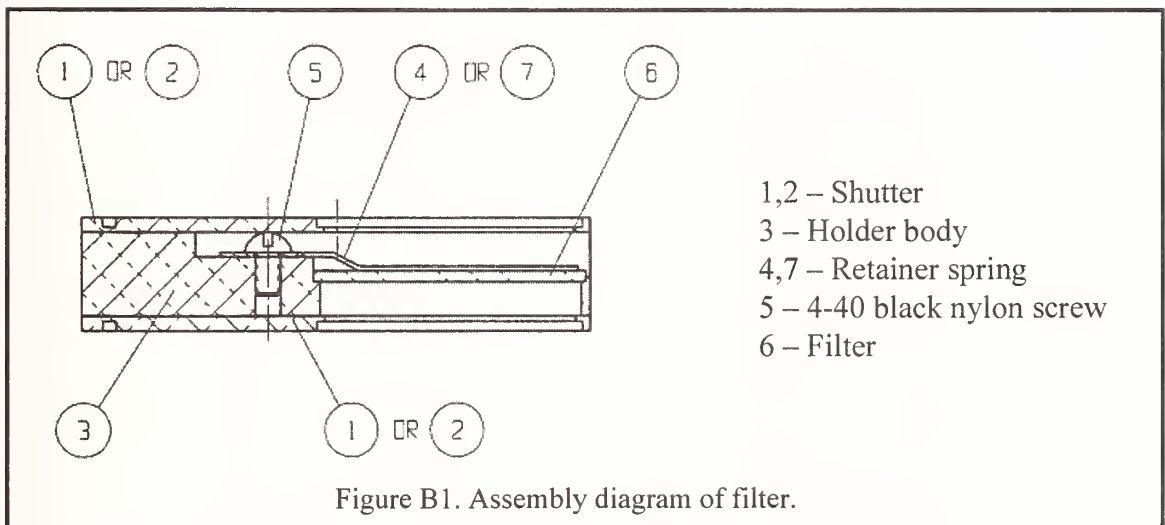

A noteworthy feature shown in Figure B2 (in the top views) is a tiny protrusion at the base of the holder, which keeps the filter from falling out of the holder. In the top right view of Figure B2, the dovetail grooves that hold the shutters in place may be seen. The shutters themselves are shown in Figure B3. They are made from black Delrin. Figure B4 shows the retaining clip, which is made from 0.5-mm thick aluminum.

The aluminum parts are black anodized, and black plastic screws are used to hold the retaining clip in place, so that all parts of the holder are black.

The default machining tolerances for the machine drawings are given in Table B1.

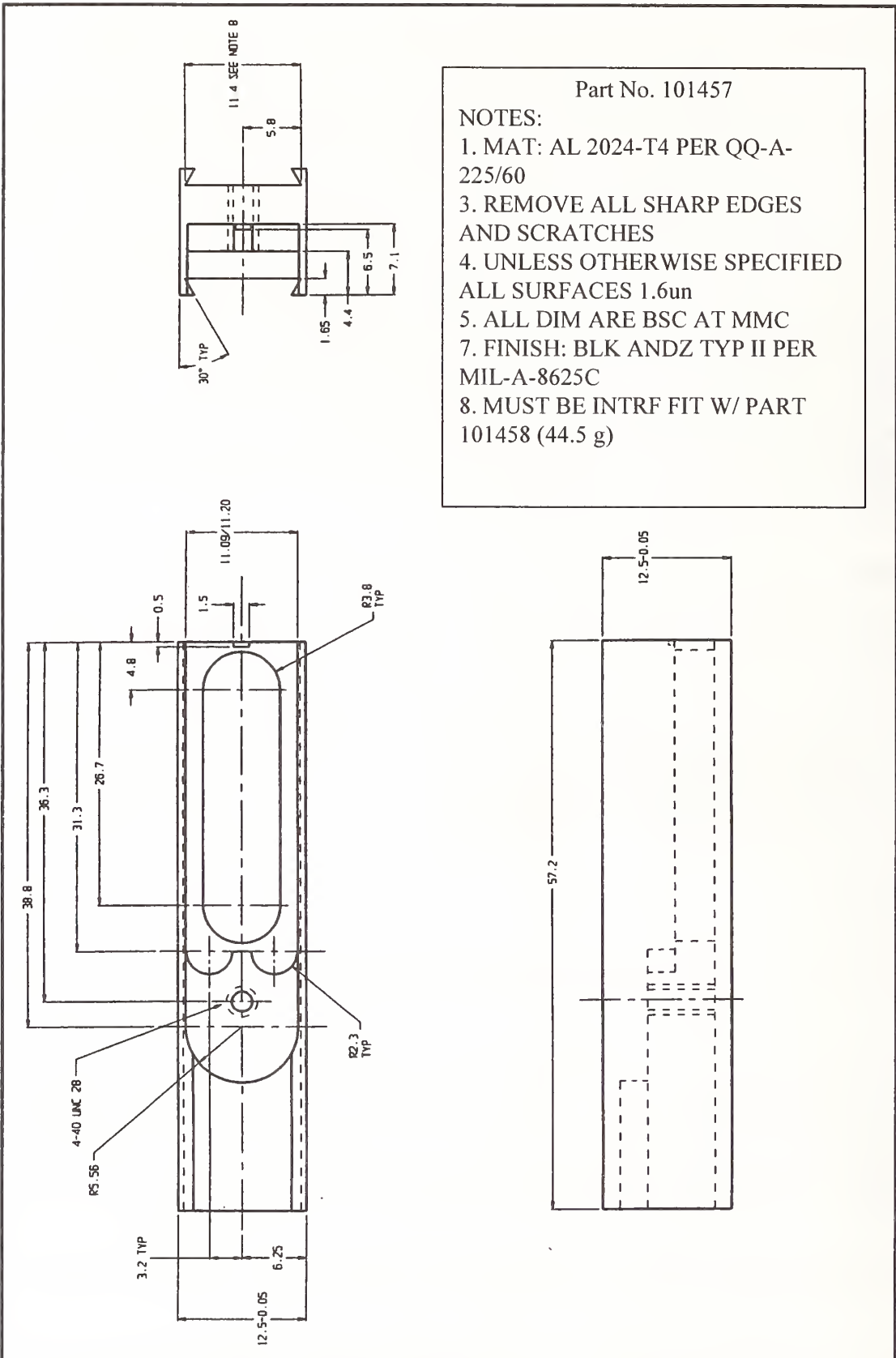

Part No. 101457

NOTES:

1. MAT: AL 2024-T4 PER QQ-A-225/60
3. REMOVE ALL SHARP EDGES AND SCRATCHES
4. UNLESS OTHERWISE SPECIFIED ALL SURFACES 1.6un
5. ALL DIM ARE BSC AT MMC
7. FINISH: BLK ANDZ TYP II PER MIL-A-8625C
8. MUST BE INTRF FIT W/ PART 101458 (44.5 g)

Figure B2. Machine drawing of filter holder body.



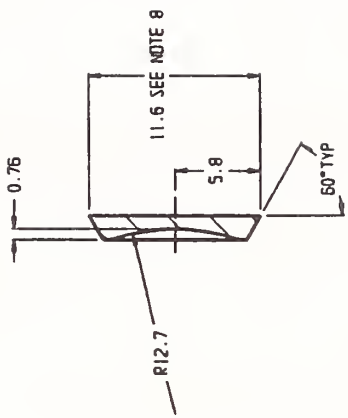
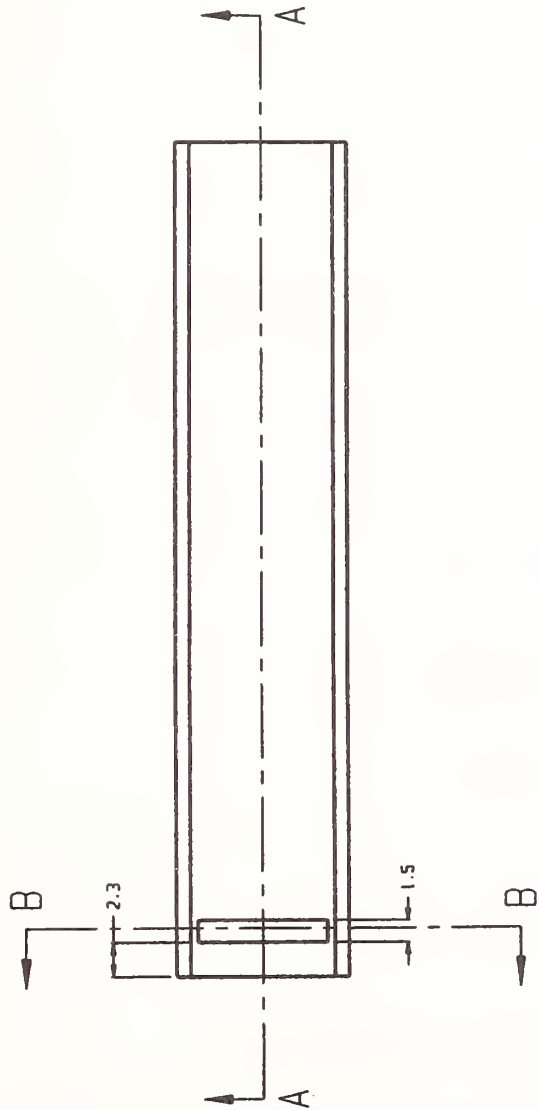

SEC B-B

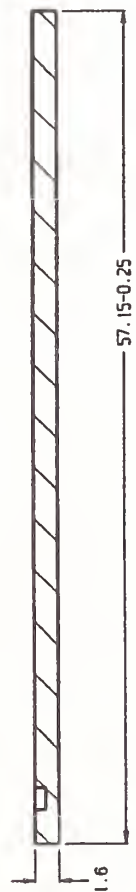

SEC A-A

Part No. 101458

NOTES:

1. MAT: DELRIN 157/507 PER L-P-392b TYP I CLASS 2 (BLK)
3. REMOVE ALL SHARP EDGES AND SCRATCHES
4. UNLESS OTHERWISE SPECIFIED ALL SURFACES 1.6un
5. ALL DIM ARE BSC AT MMC
7. FINISH: NON-REFLECTIVE FLAT BEAT BLAST (OR EQUIV) MAT PRIOR TO MFG
8. MUST BE INTRF FIT W/ PART 101457

Figure B3. Machine drawing of filter shutter.

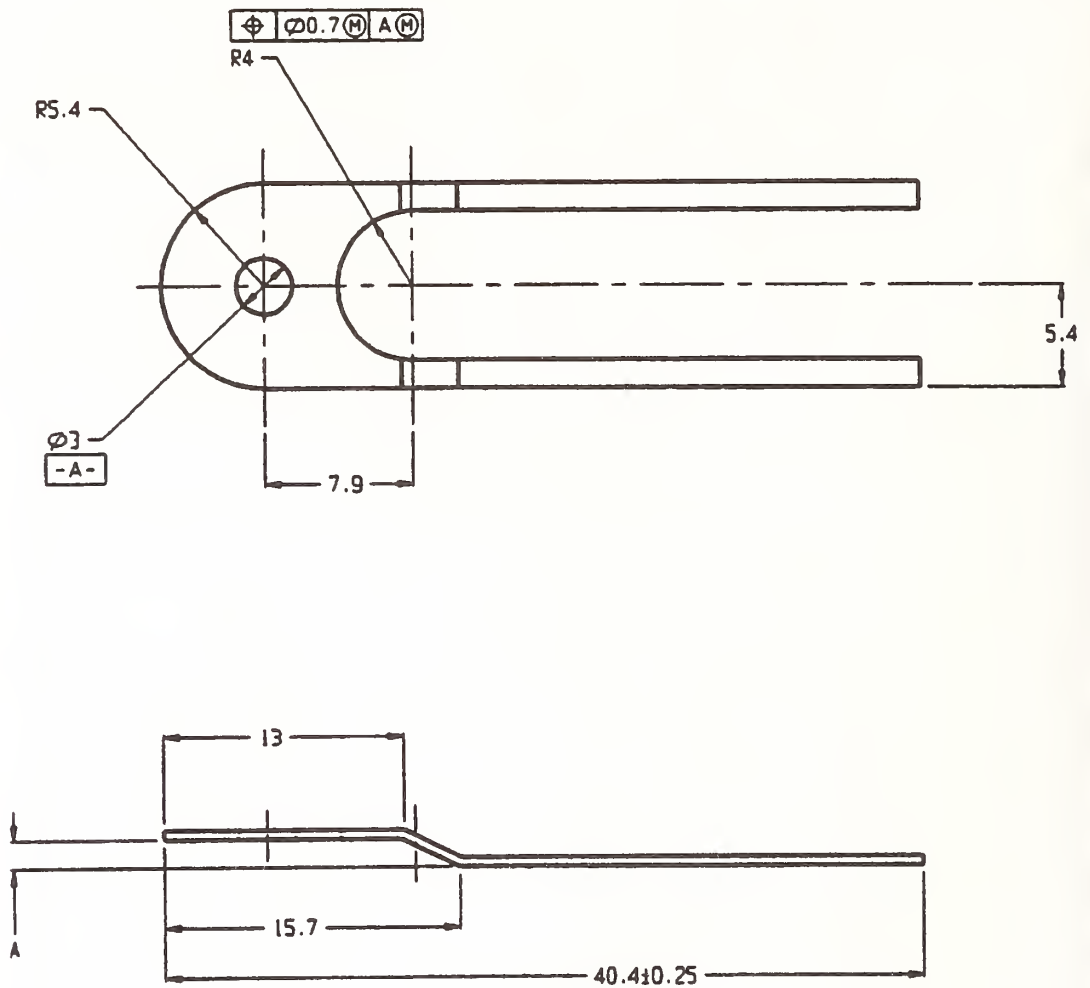

Part No. 101456

NOTES:

1. MAT: AL 6061 OR 5052 0.5 THK
3. REMOVE ALL SHARP EDGES AND SCRATCHES
4. UNLESS OTHERWISE SPECIFIED ALL SURFACES 1.6um
5. ALL DIM ARE BSC AT MMC
7. FINISH: BLK ANDZ TYP II PER MIL-A-8652C
8. DIM A = -1 1.5  
           -2 0.7  
           -3 STRAIGHT (NO OFFSET)

Figure B4. Machine drawing of filter retaining clip.

**TABLE B1**  
Metric Machining Tolerances

Range/mm	Linear Tolerance/mm	Range of Short Leg/mm	Angular Tolerance/mrad
>0.5 to 6	$\pm 0.1$	0 to 10	$\pm 17.4$
>6 to 30	$\pm 0.2$	>10 to 50	$\pm 8.7$
>30 to 120	$\pm 0.3$	>50 to 120	$\pm 5.8$



**APPENDIX C. DESIGN OF SHIPPING AND STORAGE CANISTERS AND SPRINGS FOR OPTICAL FILTERS SRMS.**

The machine drawings for the NIST SRM shipping and storage canisters are shown in Figures C1 through C4. The assembly diagram in Figure C1 shows a side-on cross section through two of the four filter storage positions. Two filter holders are shown in the storage positions, along with a retaining spring for each one. The top view – to the right of the side view – shows the orientation of all four-filter holders, the three filters and the blank.

The drawing for the canister body is shown in Figure C2, and the canister lid is drawn in Figure C3. The engraving is shown in Figure C3 for illustrative purposes, although the filter NTRM engraving would not include the registered NIST trademarks of "SRM" and the diamond "NIST" logo.

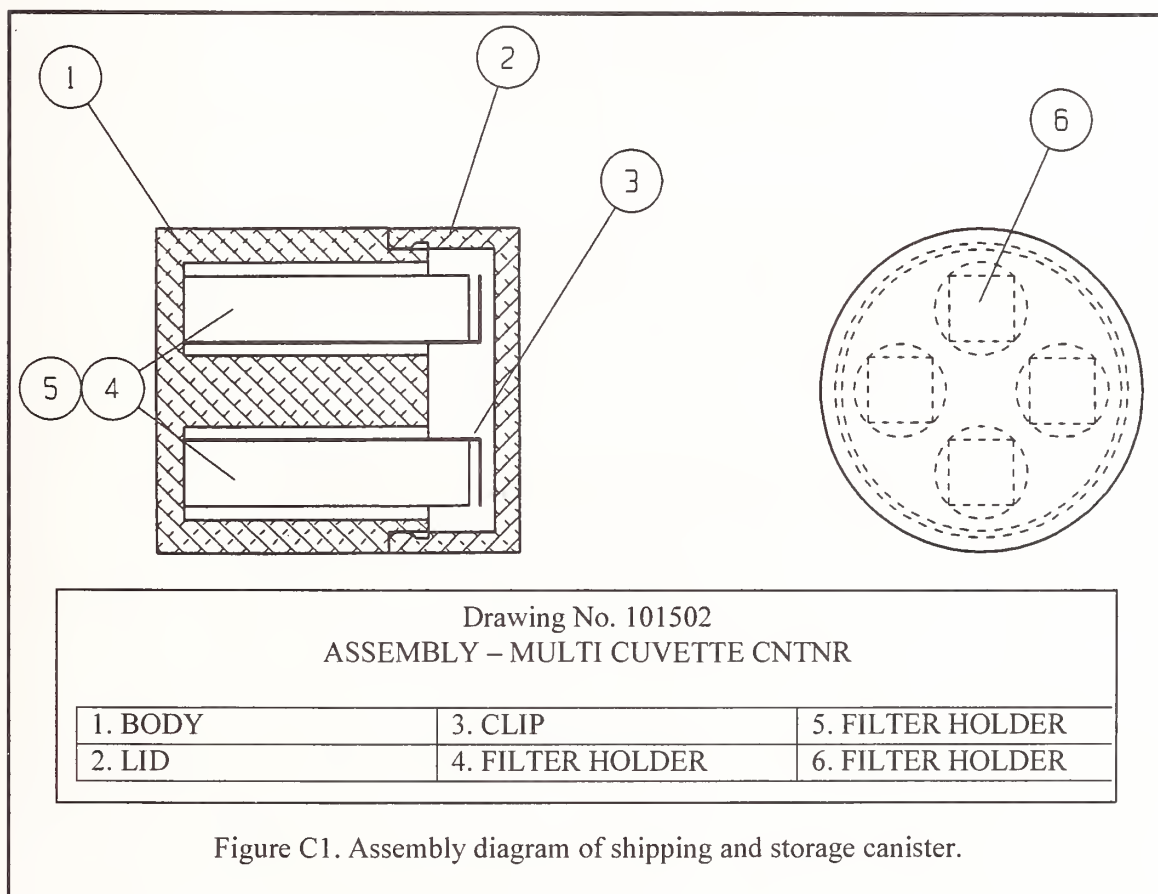

Figure C1. Assembly diagram of shipping and storage canister.

The anti-rattle retaining clip shown in Figure C4 is used for shipping the filters, and may be used for routine storage as well. They should be retained by the customer for return shipping the filters for recertification.

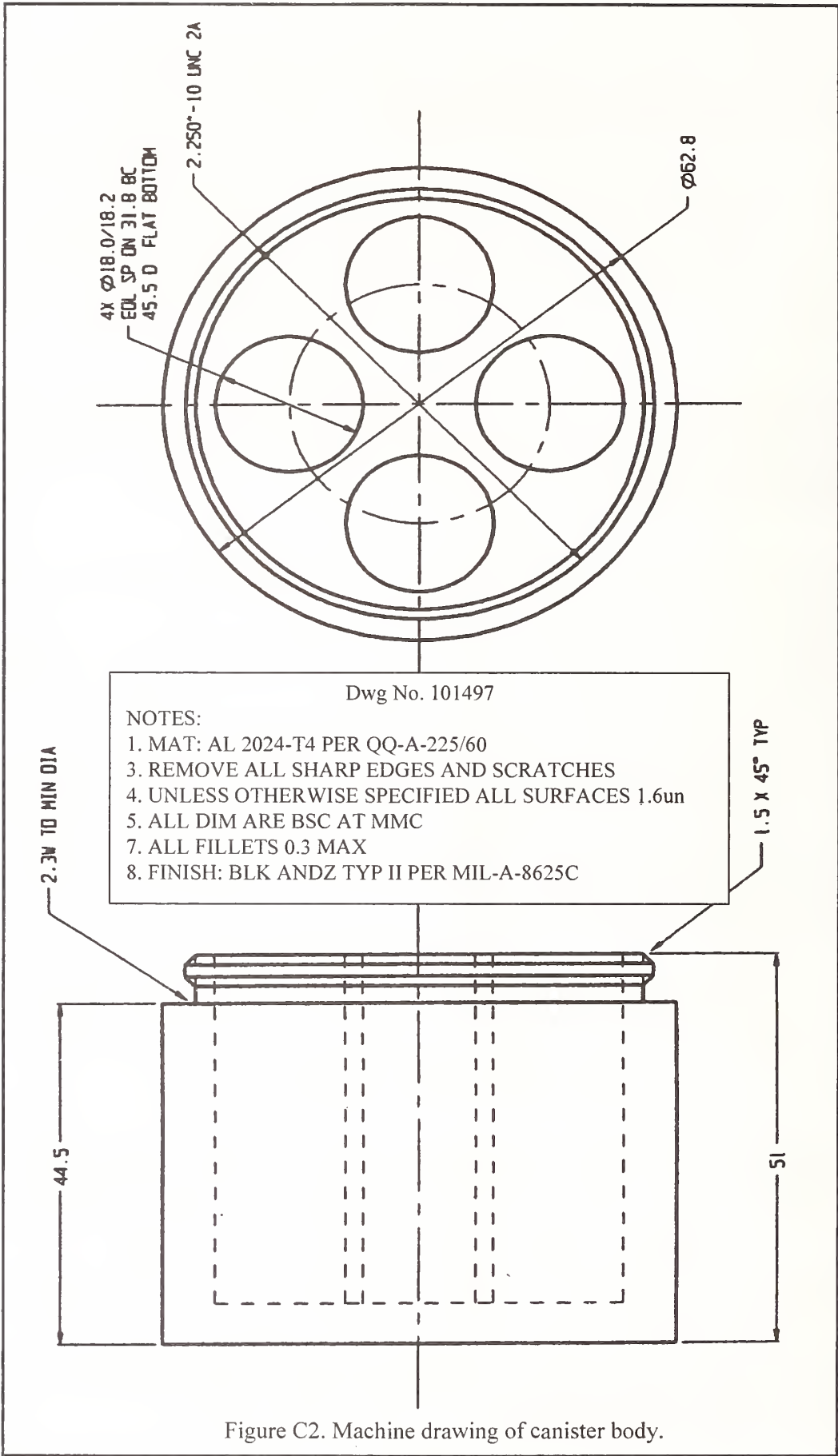
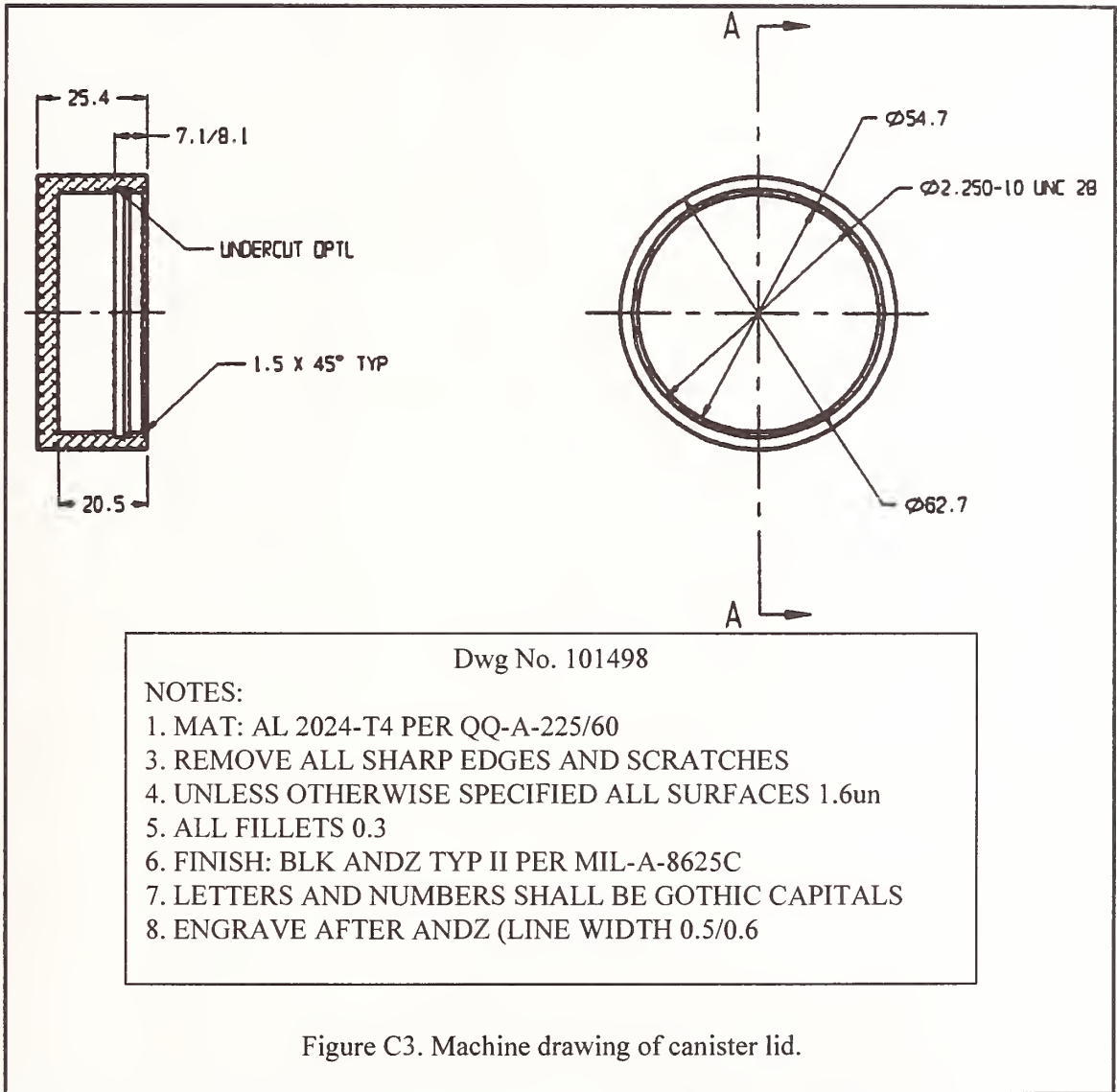
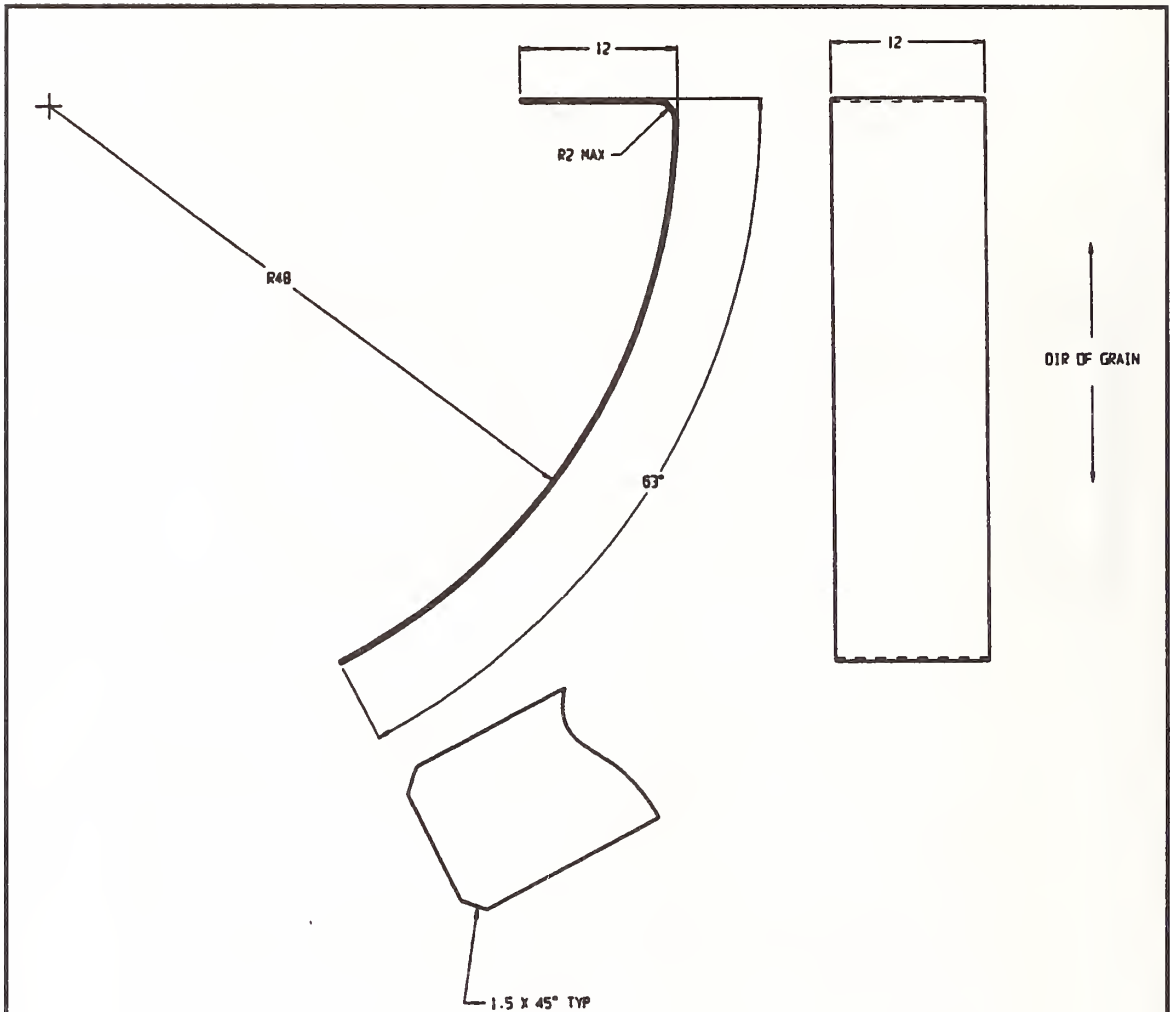

Figure C2. Machine drawing of canister body.

The default machining tolerances for the canister components are the same as for the filter holder components, and were given in Table B1.





Dwg No. 101500

NOTES:

1. MAT: PH BRZ PER QQ-B-750 0.25 THK
3. REMOVE ALL SHARP EDGES AND SCRATCHES
4. UNLESS OTHERWISE SPECIFIED ALL SURFACES 1.6um
5. BEND ACROSS GRAIN

Figure C4. Machine drawing of shipping spring.







# *NIST* Technical Publications

## *Periodical*

---

**Journal of Research of the National Institute of Standards and Technology**—Reports NIST research and development in those disciplines of the physical and engineering sciences in which the Institute is active. These include physics, chemistry, engineering, mathematics, and computer sciences. Papers cover a broad range of subjects, with major emphasis on measurement methodology and the basic technology underlying standardization. Also included from time to time are survey articles on topics closely related to the Institute's technical and scientific programs. Issued six times a year.

## *Nonperiodicals*

---

**Monographs**—Major contributions to the technical literature on various subjects related to the Institute's scientific and technical activities.

**Handbooks**—Recommended codes of engineering and industrial practice (including safety codes) developed in cooperation with interested industries, professional organizations, and regulatory bodies.

**Special Publications**—Include proceedings of conferences sponsored by NIST, NIST annual reports, and other special publications appropriate to this grouping such as wall charts, pocket cards, and bibliographies.

**National Standard Reference Data Series**—Provides quantitative data on the physical and chemical properties of materials, compiled from the world's literature and critically evaluated. Developed under a worldwide program coordinated by NIST under the authority of the National Standard Data Act (Public Law 90-396). NOTE: The Journal of Physical and Chemical Reference Data (JPCRD) is published bimonthly for NIST by the American Chemical Society (ACS) and the American Institute of Physics (AIP). Subscriptions, reprints, and supplements are available from ACS, 1155 Sixteenth St., NW, Washington, DC 20056.

**Building Science Series**—Disseminates technical information developed at the Institute on building materials, components, systems, and whole structures. The series presents research results, test methods, and performance criteria related to the structural and environmental functions and the durability and safety characteristics of building elements and systems.

**Technical Notes**—Studies or reports which are complete in themselves but restrictive in their treatment of a subject. Analogous to monographs but not so comprehensive in scope or definitive in treatment of the subject area. Often serve as a vehicle for final reports of work performed at NIST under the sponsorship of other government agencies.

**Voluntary Product Standards**—Developed under procedures published by the Department of Commerce in Part 10, Title 15, of the Code of Federal Regulations. The standards establish nationally recognized requirements for products, and provide all concerned interests with a basis for common understanding of the characteristics of the products. NIST administers this program in support of the efforts of private-sector standardizing organizations.

*Order the following NIST publications—FIPS and NISTIRs—from the National Technical Information Service, Springfield, VA 22161.*

**Federal Information Processing Standards Publications (FIPS PUB)**—Publications in this series collectively constitute the Federal Information Processing Standards Register. The Register serves as the official source of information in the Federal Government regarding standards issued by NIST pursuant to the Federal Property and Administrative Services Act of 1949 as amended, Public Law 89-306 (79 Stat. 1127), and as implemented by Executive Order 11717 (38 FR 12315, dated May 11, 1973) and Part 6 of Title 15 CFR (Code of Federal Regulations).

**NIST Interagency or Internal Reports (NISTIR)**—The series includes interim or final reports on work performed by NIST for outside sponsors (both government and nongovernment). In general, initial distribution is handled by the sponsor; public distribution is handled by sales through the National Technical Information Service, Springfield, VA 22161, in hard copy, electronic media, or microfiche form. NISTIR's may also report results of NIST projects of transitory or limited interest, including those that will be published subsequently in more comprehensive form.

**U.S. Department of Commerce**  
National Institute of Standards  
and Technology  
Gaithersburg, MD 20899-0001

Official Business  
Penalty for Private Use \$300