

UNITED STATES
DEPARTMENT OF
COMMERCE
PUBLICATION



NBS SPECIAL PUBLICATION 260-34

Standard Reference Materials:

**THERMOELECTRIC VOLTAGE OF
SILVER-28 ATOMIC PERCENT GOLD
THERMOCOUPLE WIRE, SRM 733,
VERSUS COMMON THERMOCOUPLE MATERIALS
(BETWEEN LIQUID HELIUM AND
ICE FIXED POINTS)**

U.S.
DEPARTMENT
OF
COMMERCE
National

QC
100
457
60-34
1972
c.2

NATIONAL BUREAU OF STANDARDS

The National Bureau of Standards¹ was established by an act of Congress March 3, 1901. The Bureau's overall goal is to strengthen and advance the Nation's science and technology and facilitate their effective application for public benefit. To this end, the Bureau conducts research and provides: (1) a basis for the Nation's physical measurement system, (2) scientific and technological services for industry and government, (3) a technical basis for equity in trade, and (4) technical services to promote public safety. The Bureau consists of the Institute for Basic Standards, the Institute for Materials Research, the Institute for Applied Technology, the Center for Computer Sciences and Technology, and the Office for Information Programs.

THE INSTITUTE FOR BASIC STANDARDS provides the central basis within the United States of a complete and consistent system of physical measurement; coordinates that system with measurement systems of other nations; and furnishes essential services leading to accurate and uniform physical measurements throughout the Nation's scientific community, industry, and commerce. The Institute consists of a Center for Radiation Research, an Office of Measurement Services and the following divisions:

Applied Mathematics—Electricity—Heat—Mechanics—Optical Physics—Linear Radiation²—Nuclear Radiation²—Applied Radiation²—Quantum Electronics³—Electromagnetics³—Time and Frequency³—Laboratory Astrophysics³—Cryogenics³.

THE INSTITUTE FOR MATERIALS RESEARCH conducts materials research leading to improved methods of measurement, standards, and data on the properties of well-characterized materials needed by industry, commerce, educational institutions, and Government; provides advisory and research services to other Government agencies; and develops, produces, and distributes standard reference materials. The Institute consists of the Office of Standard Reference Materials and the following divisions:

Analytical Chemistry—Polymers—Metallurgy—Inorganic Materials—Reactor Radiation—Physical Chemistry.

THE INSTITUTE FOR APPLIED TECHNOLOGY provides technical services to promote the use of available technology and to facilitate technological innovation in industry and Government; cooperates with public and private organizations leading to the development of technological standards (including mandatory safety standards), codes and methods of test; and provides technical advice and services to Government agencies upon request. The Institute also monitors NBS engineering standards activities and provides liaison between NBS and national and international engineering standards bodies. The Institute consists of the following divisions and offices:

Engineering Standards Services—Weights and Measures—Invention and Innovation—Product Evaluation Technology—Building Research—Electronic Technology—Technical Analysis—Measurement Engineering—Office of Fire Programs.

THE CENTER FOR COMPUTER SCIENCES AND TECHNOLOGY conducts research and provides technical services designed to aid Government agencies in improving cost effectiveness in the conduct of their programs through the selection, acquisition, and effective utilization of automatic data processing equipment; and serves as the principal focus within the executive branch for the development of Federal standards for automatic data processing equipment, techniques, and computer languages. The Center consists of the following offices and divisions:

Information Processing Standards—Computer Information—Computer Services—Systems Development—Information Processing Technology.

THE OFFICE FOR INFORMATION PROGRAMS promotes optimum dissemination and accessibility of scientific information generated within NBS and other agencies of the Federal Government; promotes the development of the National Standard Reference Data System and a system of information analysis centers dealing with the broader aspects of the National Measurement System; provides appropriate services to ensure that the NBS staff has optimum accessibility to the scientific information of the world, and directs the public information activities of the Bureau. The Office consists of the following organizational units:

Office of Standard Reference Data—Office of Technical Information and Publications—Library—Office of International Relations.

¹ Headquarters and Laboratories at Gaithersburg, Maryland, unless otherwise noted; mailing address Washington, D.C. 20234.

² Part of the Center for Radiation Research.

³ Located at Boulder, Colorado 80302.

UN 27 1972

Not OCC

00
7
760-34
2
5

Standard Reference Materials:

**Thermoelectric Voltage of
Silver-28 Atomic Percent Gold Thermocouple Wire, SRM 733,
Versus Common Thermocouple Materials
(Between Liquid Helium and Ice Fixed Points)**

L. L. Sparks and J. G. Hust

Institute for Basic Standards
National Bureau of Standards
Boulder, Colorado 80302

U.S.
Special Publication no. 260-34



U.S. DEPARTMENT OF COMMERCE, Peter G. Peterson, Secretary
NATIONAL BUREAU OF STANDARDS, Lewis M. Branscomb, Director,

Issued April 1972

Library of Congress Catalog Number: 72-600029

National Bureau of Standards Special Publication 260-34

Nat. Bur. Stand. (U.S.), Spec. Publ. 260-34, 34 pages (Apr. 1972)

CODEN: XNBSAV

Issued April 1972

PREFACE

Standard Reference Materials (SRM's) as defined by the National Bureau of Standards are "well-characterized materials, produced in quantity, that calibrate a measurement system to assure comparability of measurement in the nation." SRM's are widely used as primary standards in many diverse fields in science, industry, and technology, both within the United States and throughout the world. In many industries traceability of their quality control process to the national measurement system is carried out through the mechanism and use of SRM's. For many of the nation's scientists and technologists it is therefore of more than passing interest to know the details of the measurements made at NBS in arriving at the certified values of the SRM's produced. An NBS series of papers, of which this publication is a member, called the NBS Special Publication - 260 Series is reserved for this purpose.

This 260 Series is dedicated to the dissemination of information on all phases of the preparation, measurement, and certification of NBS-SRM's. In general, much more detail will be found in these papers than is generally allowed, or desirable, in scientific journal articles. This enables the user to assess the validity and accuracy of the measurement processes employed, to judge the statistical analysis, and to learn details of techniques and methods utilized for work entailing the greatest care and accuracy. It is also hoped that these papers will provide sufficient additional information not found on the certificate so that new applications in diverse fields not foreseen at the time the SRM was originally issued will be sought and found.

Inquiries concerning the technical content of this paper should be directed to the author(s). Other questions concerned with the availability, delivery, price, and so forth will receive prompt attention from:

Office of Standard Reference Materials
National Bureau of Standards
Washington, D.C. 20234

J. Paul Cali, Chief
Office of Standard Reference Materials

OTHER NBS PUBLICATIONS IN THIS SERIES

- NBS Spec. Publ. 260, Catalog of Standard Reference Materials, July 1970. 75 cents.* (Supersedes NBS Misc. Publ. 260, January 1968 and NBS Misc. Publ. 241, March 1962.)
- NBS Misc. Publ. 260-1, Standard Reference Materials: Preparation of NBS White Cast Iron Spectrochemical Standards, June 1964. 30 cents.*
- NBS Misc. Publ. 260-2, Standard Reference Materials: Preparation of NBS Copper-Base Spectrochemical Standards, October 1964. 35 cents.*
- NBS Misc. Publ. 260-3, Standard Reference Materials: Metallographic Characterization of an NBS Spectrometric Low-Alloy Steel Standard, October 1964. 20 cents.* (Out of print).
- NBS Misc. Publ. 260-4, Standard Reference Materials: Sources of Information on Standard Reference Materials, February 1965. 20 cents.* (Out of print).
- NBS Misc. Publ. 260-5, Standard Reference Materials: Accuracy of Solution X-Ray Spectrometric Analysis of Copper-Base Alloys, March 1965. 25 cents.* (Out of print).
- NBS Misc. Publ. 260-6, Standard Reference Materials: Methods for the Chemical Analysis of White Cast Iron Standards, July 1965. 45 cents.*
- NBS Misc. Publ. 260-7, Standard Reference Materials: Methods for the Chemical Analysis of NBS Copper-Base Spectrochemical Standards, October 1965. 60 cents.*
- NBS Misc. Publ. 260-8, Standard Reference Materials: Analysis of Uranium Concentrates at the National Bureau of Standards, December 1965. 60 cents.* (Out of print).
- NBS Misc. Publ. 260-9, Standard Reference Materials: Half Lives of Materials Used in the Preparation of Standard Reference Materials of Nineteen Radioactive Nuclides Issued by the National Bureau of Standards, November 1965. 15 cents.*
- NBS Misc. Publ. 260-10, Standard Reference Materials: Homogeneity Characterization on NBS Spectrometric Standards II: Cartridge Brass and Low-Alloy Steel, December 1965. 30 cents.*

- NBS Misc. Publ. 260-11, Standard Reference Materials:
Viscosity of a Standard Lead-Silica Glass, November
1966. 25 cents.*
- NBS Misc. Publ. 260-12, Standard Reference Materials:
Homogeneity Characterization of NBS Spectrometric
Standards III: White Cast Iron and Stainless Steel
Powder Compact, September 1966. 20 cents.*
- NBS Misc. Publ. 260-13, Standard Reference Materials:
Mössbauer Spectroscopy Standard for the Chemical Shift
of Iron Compounds, July 1967. 40 cents.*
- NBS Misc. Publ. 260-14, Standard Reference Materials:
Determination of Oxygen in Ferrous Materials --
SRM 1090, 1091, and 1092, September 1966. 30 cents.*
- NBS Misc. Publ. 260-15, Standard Reference Materials:
Recommended Method of Use of Standard Light-Sensitive
Paper for Calibrating Carbon Arcs Used in Testing
Textiles for Colorfastness to Light, June 1967.
20 cents.*
- NBS Spec. Publ. 260-16, Standard Reference Materials:
Homogeneity Characterization of NBS Spectrometric
Standards IV: Preparation and Microprobe Characterization
of W-20% Mo Alloy Fabricated by Powder Metallurgical
Methods, January 1969. 35 cents.*
- NBS Spec. Publ. 260-17, Standard Reference Materials:
Boric Acid; Isotopic and Assay Standard Reference
Materials, February 1970. 65 cents.*
- NBS Spec. Publ. 260-18, Standard Reference Materials:
Calibration of NBS Secondary Standard Magnetic Tape
(Computer Amplitude Reference) Using the Reference
Tape Amplitude Measurement "Process A", November 1969.
50 cents.*
- NBS Spec. Publ. 260-19, Standard Reference Materials:
Analysis of Interlaboratory Measurements on the
Vapor Pressure of Gold (Certification of Standard
Reference Material 745), January 1970. 30 cents.*
- NBS Spec. Publ. 260-20, Standard Reference Materials:
Preparation and Analysis of Trace Element Glass
Standards. (In preparation)
- NBS Spec. Publ. 260-21, Standard Reference Materials:
Analysis of Interlaboratory Measurements on the Vapor
Pressures of Cadmium and Silver, January 1971. 35 cents.*

- NBS Spec. Publ. 260-22, Standard Reference Materials:
Homogeneity Characterization of Fe-3Si Alloy,
February 1971. 35 cents.*
- NBS Spec. Publ. 260-23, Standard Reference Materials:
Viscosity of a Standard Borosilicate Glass, December 1970.
25 cents.*
- NBS Spec. Publ. 260-24, Standard Reference Materials:
Comparison of Redox Standards, January 1972. \$1.00.*
- NBS Spec. Publ. 260-25, Standard Reference Materials:
A Standard Reference Material Containing Nominally Four
Percent Austenite, February 1971. 30 cents.*
- NBS Spec. Publ. 260-26, Standard Reference Materials:
National Bureau of Standards-U.S. Steel Corporation
Joint Program for Determining Oxygen and Nitrogen in
Steel, February 1971. 50 cents.*
- NBS Spec. Publ. 260-27, Standard Reference Materials:
Uranium Isotopic Standard Reference Materials,
April 1971. \$1.25.*
- NBS Spec. Publ. 260-28, Standard Reference Materials:
Preparation and Evaluation of SRM's 481 and 482 Gold-Silver
and Gold-Copper Alloys for Microanalysis, August 1971.
\$1.00.*
- NBS Spec. Publ. 260-29, Standard Reference Materials:
Calibration of NBS Secondary Standard Magnetic Tape
(Computer Amplitude Reference) Using the Reference
Tape Amplitude Measurement "Process A-Model 2",
June 1971. 60 cents.*
- NBS Spec. Publ. 260-30, Standard Reference Materials:
Standard Samples Issued in the USSR (A Translation
from the Russian), June 1971. \$1.00.*
- NBS Spec. Publ. 260-31, Standard Reference Materials:
Thermal Conductivity of Electrolytic Iron SRM 734 from
4 to 300K, November 1971. 35 cents.*
- NBS Spec. Publ. 260-32, Standard Reference Materials:
The Cooperative Study of Temperature Scale Standards
for DTA by ICTA and NBS. (In preparation)
- NBS Spec. Publ. 260-33, Standard Reference Materials:
Comparison of Original and Supplemental SRM 705,
Narrow Molecular Weight Distribution Polystyrene,
H. L. Wagner. (In preparation).

NBS Spec. Publ. 260-34, Standard Reference Materials:
Thermoelectric Voltage. (This publication).

NBS Spec. Publ. 260-35, Standard Reference Materials:
Thermal Conductivity of Austenitic Stainless Steel,
SRM 735 from 5 to 280K*. (In preparation).

*Send order with remittance to: Superintendent of Documents,
U.S. Government Printing Office, Washington, D. C. 20402.
Remittance from foreign countries should include an
additional one-fourth of the purchase price for postage

Table of Contents

1. Introduction	2
2. Material Characterization and Specimen Preparation	4
3. Thermocouple Comparator	8
4. Data Analysis	9
5. Results and Discussion	11
6. Acknowledgements	12
7. References and Footnotes	13

List of Figures

Figure 1.	Thermoelectric voltage of <u>Ag</u> - 25 at % Au versus <u>Ag</u> - X at % Au between 4 and 76 K. Error bars represent $\pm 2\sigma$ values	16
Figure 2.	Electrical residual resistivity of <u>Ag</u> - X at % Au alloys	17
Figure 3.	Electrical residual resistivity ratio of the ends of the five spools of SRM 733. The standard deviation of these measurements is 0.0014	18
Figure 4.	Thermoelectric comparisons of <u>Ag</u> - 28 at % Au wires, annealed at various currents, to an SRM 733 wire (<u>Ag</u> - 28 at % Au annealed with 3.5 A). The comparisons were made between 4 and 273.15 K and the error bars represent $\pm 2\sigma$ values.	19
Figure 5.	Thermoelectric intercomparisons of SRM 733 wire from each of the five stock spools. Intercomparisons were made with respect to a SRM 733 comparator between 4 and 273.15 K and a Pt-67 versus SRM 733 values have been normalized to show only the spool-to-spool variations. The error bars represent $\pm 2\sigma$ values	20

Figure 6a.	Typical Thermocouple Arrangement	21
Figure 6b.	Comparator Circuit for Calibration of Standard Reference Thermocouple Wires	21
Figure 7a.	Details of comparator construction (pictorial view)	22
Figure 7b.	Details of comparator construction (junction terminal blocks)	23
Figure 7c.	Details of comparator construction (wiring diagram)	24
Figure 8.	Intercomparison of three SRM 733 thermocouple comparators via a common thermocouple wire. The error bars represent $\pm 2 \sigma$ values	25

List of Tables

Table 1.	Chemical Composition of SRM 733	14
Table 2.	Thermoelectric voltage for SRM 733 versus commonly used thermocouple wire between liquid helium and ice fixed points	15

THERMOELECTRIC VOLTAGE OF SILVER - 28
ATOMIC PERCENT GOLD THERMOCOUPLE WIRE, SRM 733,
VERSUS COMMON THERMOCOUPLE MATERIALS
(Between Liquid Helium and Ice Fixed Points)*

L. L. Sparks and J. G. Hust

Institute for Basic Standards
National Bureau of Standards
Boulder, Colorado 80302

Industry wide standardization of thermocouple wire depends, in part, on the ability to thermoelectrically compare commercial wires with a Standard Reference Material (SRM). The alloy Ag - 28 at % Au, SRM 733, meets the requirements of a thermoelectric reference material, particularly in the temperature range of liquid helium and liquid hydrogen where Pt-67 is not adequate. Thermoelectric voltage comparisons are reported for SRM 733 versus common thermocouple materials between liquid helium and ice fixed points. Detailed standard reference data based on these common materials are given in NBS Monograph 124. The comparisons were made in a thermocouple comparator which was designed to be a permanent holder of three SRM 733 wires; the comparator allows tests to be made without handling the standard wires. Details of the construction, testing, and analysis of the comparators are given.

Key words: Cryogenics; Seebeck voltage; silver - gold alloy; standard reference material; thermocouple.

* This work was carried out at the National Bureau of Standards, Boulder, Colorado, under the sponsorship of the National Bureau of Standards, Office of Standard Reference Materials (NBS-OSRM), Washington, D. C.

1. Introduction

The ability to standardize thermocouple wires depends, in part, on the availability of a reliable Standard Reference Material (SRM). In addition, thermocouple materials must be well characterized if excessive manufacturer-to-manufacturer, batch-to-batch, or spool-to-spool variations are to be avoided. Because of the difficulty of accurately characterizing thermocouple wires in terms of composition or other commonly used parameters, they must be controlled primarily by direct thermoelectric measurements. If these direct thermoelectric measurements are made with respect to an SRM which, in turn, is compared to standard reference data, then industry-wide uniformity is possible. The first step of this program, to establish such standard reference data for commonly used thermocouples at cryogenic temperatures, has been completed by Sparks, et al., [1] at the National Bureau of Standards, Boulder, Colorado. The next step, to establish an SRM, is the subject of this paper.

The general requirements for a thermoelectric SRM are that the material:

- (1) be insensitive in thermoelectric power to small changes in composition,
- (2) be readily fabricated into the desired form and quantity at reasonable cost, and

(3) be easy to use in practice, i. e., be flexible, ductile, and chemically compatible with the measurement system.

In some instances it is also important to have a material with low thermal conductivity and a thermoelectric power near the median of the thermoelectric power of commonly used thermocouple materials.

Tests made earlier in this laboratory by Powell, et al., [2] on a series of silver-gold alloys (20 to 40 atomic percent gold) indicated that silver with approximately 25 to 30 at % gold met the above requirements. Since that time, more extensive tests have been performed on six silver-gold alloys (25, 26, 27, 28, 29, and 30 at % gold). These tests were conducted with experimental arrangements described in a later section. The results of these measurements, figure 1, show that the systematic emf variation among these wires (from 4 to 76 K) is small (approximately $0.1 \mu\text{V}/\text{at } \%$ Au). Based on the previous measurements by Powell, et al., [2] and these later measurements, silver - 28 at % gold was selected as a suitable low temperature thermoelectric SRM. This report describes the research performed to establish and maintain this silver-gold alloy as an SRM.

Traditionally, platinum is used by thermocouple wire manufacturers for production control. At temperatures above approximately 50 K platinum is a suitable SRM; however, below 50 K the thermoelectric power of platinum becomes sensitive to physical imperfections and trace chemical impurities, notably iron. This low-temperature sensitivity to imperfections is typical for pure materials. In view of past use, applicability at higher temperatures, extensive characterization, and availability in the form of homogeneous wire, platinum will also be maintained as a low temperature thermoelectric SRM. A report on platinum as such a

standard will be a subsequent publication in this series. It is to be remembered that at lower temperatures (~ 4 K) spurious emfs generated by inhomogeneities in platinum may be as much as ten times greater than the spurious emfs found with the silver-28 at % gold alloy. Thus, platinum is recommended for measurements at temperatures as low as liquid nitrogen (76 K) and the silver-gold alloy is recommended for measurements below 76 K.

2. Material Characterization and Specimen Preparation

A specially prepared lot of Ag-28 at % Au alloy was fabricated as wire for further testing and to establish and maintain a thermoelectric standard. The metal was alloyed and cast in 2.5 cm diameter billets. The billets were swaged to 0.6 cm diameter, drawn to 0.06 cm with carbide dies, and finally drawn to 0.020 cm (0.008 inch) wire with diamond dies. Drawing was accomplished without lubricant and without annealing or etching between passes. The wire was supplied uninsulated to facilitate later annealing. Annealing is necessary to eliminate physical damage introduced by normal handling, e. g., winding and unwinding from the spools. The chemical composition of the wire is given in table 1.

The Ag-Au standard wire was supplied on five spools. Specimens were cut from both ends of each spool for characterization measurements. The residual resistivity ratios ($RRR = \rho_{273\text{ K}}/\rho_{4\text{ K}}$, where ρ = electrical resistivity) of these 10 specimens were determined after annealing at 400°C for one hour. Variation in the residual resistivity ratio of annealed specimens indicates variation in composition. The composition variation can be determined from RRR variation if one knows the specific resistivity, $\partial\rho_o/\partial C$ (ρ_o = residual resistivity and C = relative composition in atomic units). Blatt[3] has compiled values of specific

resistivity for many elements and lists $0.4 \mu\Omega\text{cm/at } \% \text{ Au}$ in Ag. We have performed RRR measurements on Ag-13.5 at $\% \text{ Au}$ as well as the Ag-28 at $\% \text{ Au}$ alloy. From an approximate ($\pm 3\%$) resistivity measurement and by the application of Matthiessen's rule, we obtain values of ρ_0 versus composition as shown in figure 2. Blatt's [3] specific resistivity, $\partial\rho_0/\partial C$, is in reasonable agreement with the slope of our curve in figure 2 at low Au concentration. If we assume the form of the residual resistivity - composition relation suggested by Nordheim [4], $\rho_0 = \alpha C(1 - C)$, and evaluate the best estimate of α , we obtain $0.35 \mu\Omega\text{cm/at } \% \text{ Au}$ as compared to $0.40 \mu\Omega\text{cm/at } \% \text{ Au}$ listed by Blatt [3].

Using Nordheim's rule, we have shown that the change in atomic percent composition, ΔC , is related to change in residual resistivity ratio, ΔRRR , as follows:

$$\Delta C = \frac{\Delta\text{RRR } C(1 - C)}{(\text{RRR} - 1)(1 - 2C)} . \quad (1)$$

The determination of RRR instead of ρ_0 eliminates the need to determine the form factor (cross-sectional area/length) of the specimen; therefore, the results are both more precise and accurate. The range of RRR variation, ΔRRR , measured for the ten specimens from the ends of the five spools is 0.0044, as shown in figure 3. This variation in RRR corresponds to about 0.7 atomic percent variation in gold concentration and apparently is random over the five spools. The thermoelectric variation caused by a 0.7 atomic percent composition variation is undetectable, as shown in figure 1. Thus, specimens from the five spools of material should be thermoelectrically indistinguishable.

Specimen preparation is important in obtaining uniform standard reference thermocouple specimens. The wire must be cleaned, annealed, and subsequently handled with care to avoid chemical contamination or physical damage, either of which can affect thermoelectric power. Several preanneal cleaning and etching procedures were considered in order to prevent diffusion of impurities into the wire during the anneal. It was determined that cleaning with a degreasing agent followed by rinsing in distilled water was adequate. Etching the surface did not make a detectable difference in thermoelectric properties. Several annealing procedures were also investigated. As a first attempt, the wire was degreased, washed in distilled water, and wrapped on a fused quartz spool. This wire was annealed in an air furnace for one hour at 400°C. This procedure proved unsatisfactory because there was a tendency for the wire to adhere to the spool after annealing; removing the wire from the spool undoubtedly introduced some strain. Resistance annealing, i. e., self heating caused by an electric current through the wire, resulted in wires which were thermoelectrically more reproducible. This procedure is convenient and can be done with less chance of chemical contamination or physical strain. The effect of different annealing currents is shown in figure 4. Based on this, an annealing current of 3.5 A through the 0.020 cm diameter wire was selected as optimum. This current produced a dull red glow (hardly visible in a darkened room) and resulted in a well-annealed wire. We found that the Ag-Au wire is weakened and will break with very low stress after a 4.3 A anneal. This may be caused by grain growth across the wire during the anneal and subsequent hydrogen diffusion into the grain boundary. These 0.020 cm diameter wires melt at currents slightly above 4.3 A. The recommended wire preparation procedure is:

1. Degrease and rinse in distilled water.
2. Suspend wire in air and connect to a current source.
3. Continuously increase current to obtain proper annealing temperature (3.5 A for the 0.020 cm diameter wire).
4. Maintain this temperature for about 30 seconds.
5. Gradually decrease current to zero over about 15 seconds.
6. Handle with care: avoid unnecessary mechanical stresses of the wire prior to use.

Specimen wires from each of the five spools of the Ag-Au alloy were thermoelectrically intercompared after being prepared as above. The results, shown in figure 5, show that statistically no difference in thermoelectric power exists among the wires from the five spools. These comparisons were made with respect to a SRM 733 comparator for temperatures from 4 to 273.15 K and a Pt-67 comparator for temperatures from 76 to 273.15 K. The results from the Pt-67 comparator have been normalized so as to show only the spool-to-spool variation. These thermoelectric intercomparisons are in accord with the previously mentioned resistivity results.

The preceding results, in some instances, were obtained with thermocouple comparators. The design and construction of the comparators are described in the next section.

3. Thermocouple Comparator

The basic measurement arrangement for a thermocouple calibration measurement is shown in figure 6a. This arrangement is used to determine the difference in thermoelectric emfs, $E_A - E_B$, of wires A and B between temperatures T_1 and T_2 . The average thermopower, S , of the thermocouple is defined by $(E_A - E_B)/(T_2 - T_1)$. Errors are introduced into this measurement by (1) the presence of spurious thermal emfs caused principally by wire inhomogeneity in regions of high temperature gradient, and (2) improper thermal anchoring to each of the baths. It is possible to reduce the systematic effect of spurious voltages by taking readings at different immersion depths and by measuring with respect to more than one reference wire.

The thermal anchoring problem is solved by reducing the thermal resistance between the wires and the constant temperature baths. This is accomplished by intimate contact between the wires and the liquid over a sufficient length leading up to the thermocouple junctions. This problem has been examined carefully both experimentally and theoretically [5]. No detectable error due to inadequate thermal anchoring is believed present in the thermoelectric emfs reported here. The thermocouple comparator is shown schematically in figure 6b. The selector switch allows one to measure the thermoelectric emf of the test wire with respect to each of the reference wires as well as to intercompare each of the reference wires. Intercomparison of the reference wires is done to detect possible deterioration of these wires or other comparator components. The construction details of the comparator are shown in figures 7a, 7b, and 7c.

4. Data Analysis

The experimental data, depicted in figure 6b, are designated as E_{T1} , E_{T2} , E_{T3} , E_{12} , E_{23} , and E_{13} . The subscript T indicates the test wire while 1, 2, and 3 refer to the three standard reference wires permanently installed in the comparator. A set of six voltages is obtained for each immersion depth in the forward (T_1 to T_2) direction as well as in the reverse (T_2 to T_1) direction. The values obtained in the forward direction, averaged over the various depths, will be designated by $E_{ij}(F)$, while the reverse readings are designated $E_{ij}(R)$. The sets of six voltages are illustrated in the following measurement graph.

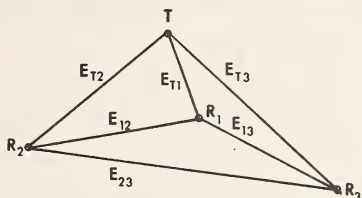

In this figure the vertices represent the wires illustrated and defined in figure 6b, while the lines represent the emfs of the associated thermocouple pairs. For convenience, the vertical position of the vertices designate the relative position of each wire in the electromotive series, e. g., the most thermoelectrically positive wire is denoted by the uppermost vertex. The most probable (weighted averages) values \bar{E}_{T1} , \bar{E}_{T2} , \bar{E}_{T3} , \bar{E}_{12} , \bar{E}_{13} , and \bar{E}_{23} are obtained from the redundant but independent equations based on the various paths which can be used to define each E_{ij} . There are four such independent paths which can be used to obtain four estimates of each measured voltage. As an example, the four independent paths used to estimate E_{T1} yield the following four equations:

$$\begin{aligned}
 (6) \quad E_{T1}^{(1)} &= E_{T1} \\
 (3) \quad E_{T1}^{(2)} &= E_{T2} - E_{12} \\
 (3) \quad E_{T1}^{(3)} &= E_{T3} - E_{13} \\
 (2) \quad E_{T1}^{(4)} &= E_{T3} - E_{12} - E_{23}.
 \end{aligned}$$

The relative weighting, assuming the same variance for each measured voltage, is shown in parenthesis before each equation. The average value, E_{T1} , is then

$$\bar{E}_{T1} = [6 E_{T1} + 3(E_{T2} - E_{12}) + 3(E_{T3} - E_{13}) + 2(E_{T3} - E_{12} - E_{23})]/14.$$

Values of \bar{E}_{ij} are obtained with such equations for the forward and reverse directions for each immersion depth. These values are then averaged to obtain the final value of E_{ij} . The values E_{T1} , E_{T2} , and E_{T3} are further averaged to obtain the best estimate of the emf of the test wire with respect to the SRM.

The values E_{12} , E_{13} , and E_{23} , similarly determined, are used to detect possible systematic changes among the reference wires. Control charts of E_{12} , E_{13} , and E_{23} will be maintained to detect such changes in the comparators. To further reduce the possibility of undetected changes in reference wires, three comparators have been built. The first or working standard will be used for routine testing; the second or primary standard will be used occasionally for comparison to the working comparator. The third comparator will be considered as a replacement for either of the others. Occasional intercomparisons will be made among all three comparators. Figure 8 illustrates the present intercomparisons of these three comparators.

The determination of the emf of a test wire with respect to the standard reference thermocouple wire is summarized below:

- (1) Record the six emfs illustrated in the previous measurement graph.
- (2) Repeat step 1 for three immersion depths to randomize spurious emfs.
- (3) Repeat (1) and (2) with comparator reversed in the baths.
- (4) Compute the most probable values of the six sets of six voltages using all of the redundancy in the data, both for the forward and reverse directions.
- (5) Compute the average emf for the test wire with respect to the reference standard

$$E_{TR} = \left[\left(E_{T1} + E_{T2} + E_{T3} \right)_{FWD} / 3 + \left(E_{T1} + E_{T2} + E_{T3} \right)_{REV} / 3 \right] / 2$$

and the variance of this emf. This variance is based upon the random scatter indicated by the redundancy of these measurements.

5. Results and Discussion

SRM 733 is intended for use as a standard reference thermocouple wire at low temperatures. In order for this wire to be useful, one must know the emf generated by this wire with respect to commonly used thermocouple materials. The temperature interval chosen for standardization of these wires with respect to SRM 733 is 4 to 273.15 K. The data are based on the extensive measurements of Sparks, et al., [1] and more recent measurements as explained in table 2. The emf of SRM 733 with respect to commonly used wires over the range 4 to 273.15 K are presented in table 2.

Standardization measurements have been made at several intra-spool locations to insure that the variability of SRM 733 does not exceed that reported here. As pointed out earlier, this possibility is remote because the emf of SRM 733 is insensitive to composition change.

Consideration has been given to extending the calibration range of SRM 733 to higher temperatures. The upper limit of usefulness would be dictated by the temperature produced by the optimum anneal described in this paper. This temperature is approximately 500°C. At the present time the demand for this extension does not justify the additional effort, especially since Pt-67 can be used in this range.

SRM 733, issued as 32 AWG wire, 3 meters long, may be ordered from the Office of Standard Reference Materials, Room 3314, Chemistry Building, National Bureau of Standards, Washington, D. C. 20234. (Longer continuous lengths in multiples of 3 meters can be obtained by special order to the OSRM).

6. Acknowledgements

We wish to thank the thermocouple manufacturers, especially Sigmund-Cohn Corp., Cominco American, Inc., and Engelhard Industries, Inc., for their cooperation in this program. This program was initiated and directed in its early stages by R. L. Powell; we also thank him for his many suggestions throughout the program.

7. References and Footnotes

- [1] Sparks, L. L., Powell, R. L., and Hall, W. J., Reference Tables for Low-Temperature Thermocouples, NBS (U.S.), Monogr. 124.
- [2] Powell, R. L., Caywood, L. P., Jr., and Bunch, M. D., Low Temperature Thermocouples, Temperature-Its Measurement and Control in Science and Industry 3, part 2, 65 (1962).
- [3] Blatt, F. J., Physics of Electronic Conduction in Solids, McGraw-Hill Book Co., N. Y., p. 199 (1968).
- [4] Ziman, J. M., Electrons and Phonons, Oxford at the Clarendon Press, p. 337 (1960).
- [5] Hust, J. G., Thermal Anchoring of Wires in Cryogenic Apparatus, Rev. Sci. Instr. 41, 622-624 (1970).
- [6] Trademark - Wilbur B. Driver Co.
- [7] Trademark - Driver-Harris Co.
- [8] Trademark - Kanthal Corp.
- [9] Trademark - Hoskins Manufacturing Co.
- [10] The use of tradenames of specific products is essential to the proper understanding of the work presented here. Their use in no way implies approval, endorsement, or recommendation by NBS.

Table 1. Chemical Composition of SRM 733

<u>Element</u>	ppm, by wt
Al	0.5
Ca	0.5
Cu	0.3
Fe	2.0
Pb	0.3
M	0.5
Ni	0.2
Si	2.0
Au	28 at %
Ag	balance

Table 2. Thermoelectric voltage for SRM 733 versus commonly used thermocouple wire between liquid helium and ice fixed points.

<u>Thermocouple</u>	<u>EMF, $\mu\text{V}^{* \dagger}$</u>
Pt vs SRM 733	541 \pm 3
KP or EP** vs SRM 733	4098.3 \pm 0.8
TP** vs SRM 733	521.8 \pm 0.8
SRM 733 vs EN or TN**	5735.2 \pm 0.8
SRM 733 vs KN**	2358.7 \pm 0.8

* These data are calculated from reference data by Sparks, et al., [1] and more recent comparisons of the emf of SRM 733 (resistance annealed at 3.5 A) to the Ag-28 at % Au wire used in [1] which was oven annealed at 400°C for 1 hour. The Pt-67 wire used here was resistance annealed at 1095°C for 1 minute.

† The uncertainties given are twice the estimated standard deviations. The larger uncertainty for Pt reflects the sensitivity of this pure material to trace impurities at liquid helium temperature. The effect of these impurities is strongly dependent on the temperature distribution along the wire. For dip tests, where the temperature gradient along the wire is extremely localized, a range of thermal voltages as large as 15 μV has been observed.

** EN or TN A copper-nickel alloy, constantan, Cupron [6], Advance [7], Thermo Kanthal JN [8].

 KP or EP A nickel-chromium alloy, Chromel [9], Tophel [6], T-1 [7], Thermo Kanthal KP [8].

 KN A nickel-aluminum alloy, Alumel [9], Nial [6], T-2 [7], Thermo Kanthal [8].

 TP Copper, usually electrolytic tough pitch.

The use of trade names does not constitute an endorsement of any manufacturer's products. Materials manufactured in compliance with established standards are equally suitable.

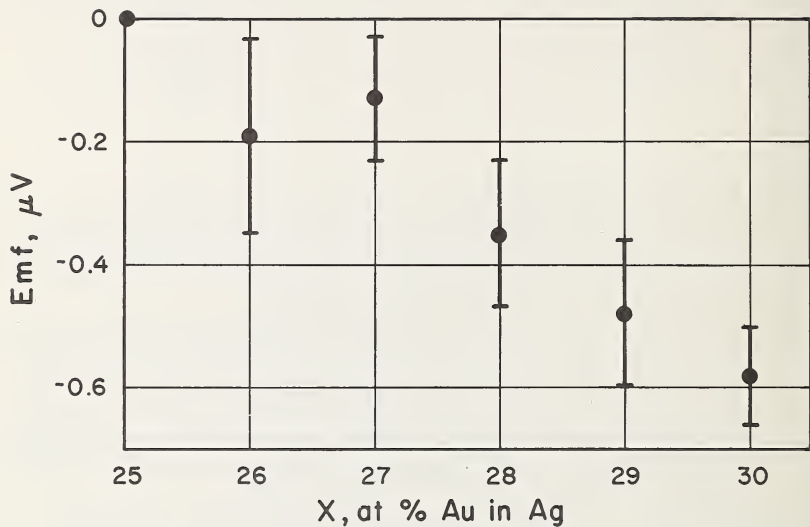

Figure 1. Thermoelectric voltage of Ag-25 at % Au versus Ag-X at % Au between 4 and 76 K. Error bars represent $\pm 2\sigma$ values.

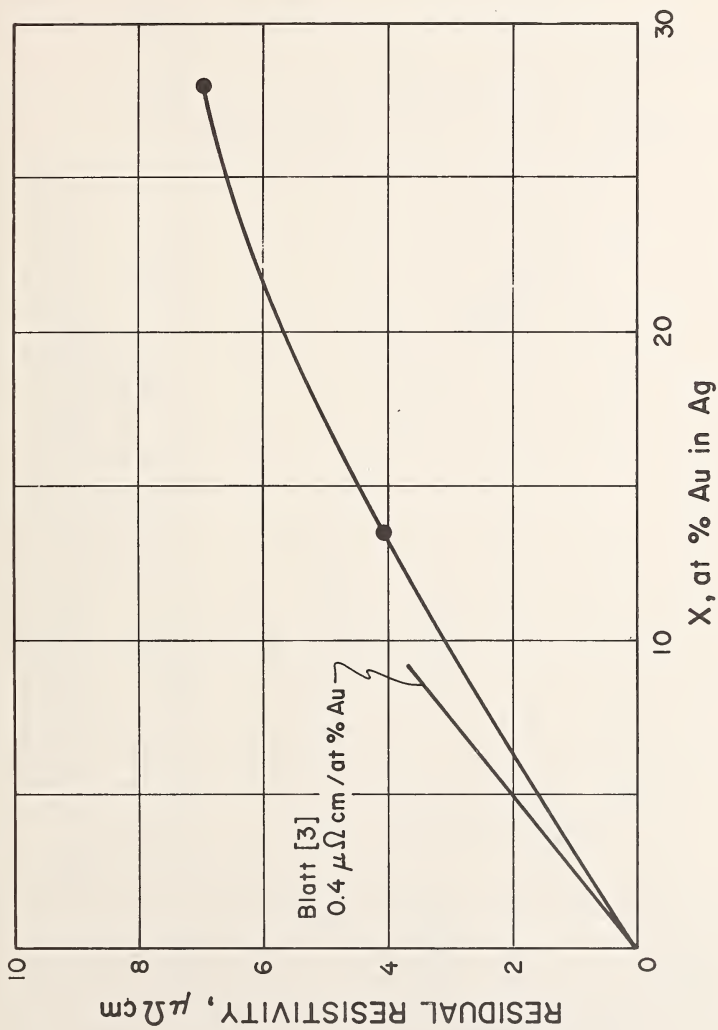

Figure 2. Electrical residual resistivity of Ag-X at % Au alloys.



Figure 3. Electrical residual resistivity ratio of the ends of the five spools of SRM 733. The standard deviation of these measurements is 0.0014.

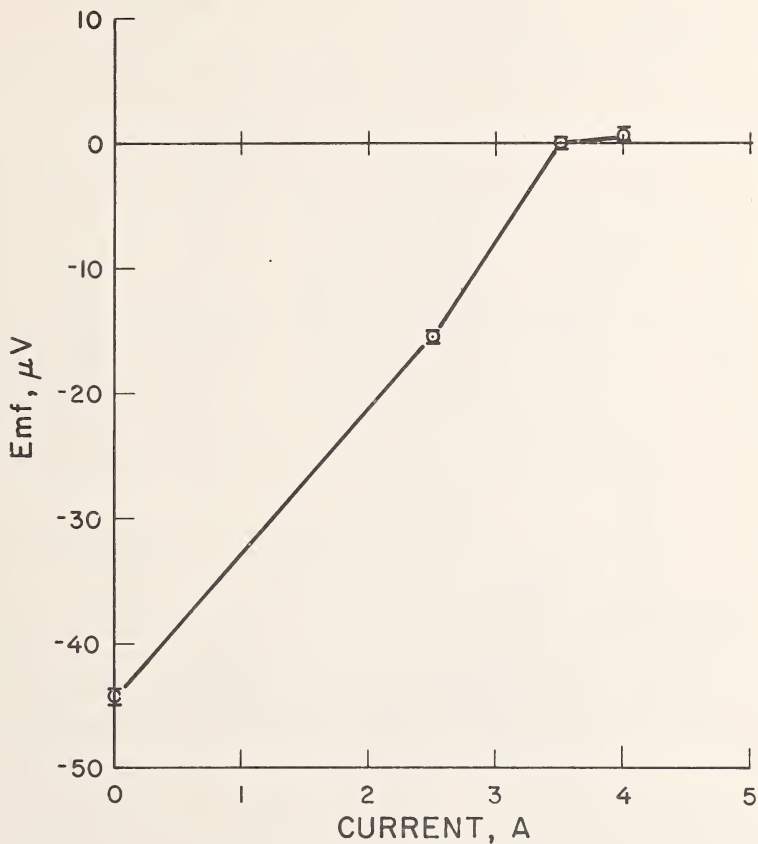

Figure 4. Thermoelectric comparisons of $\underline{\text{Ag}}\text{-28}$ at % Au wires, annealed at various currents, to an SRM 733 wire ($\underline{\text{Ag}}\text{-28}$ at % Au annealed with 3.5 A). The comparisons were made between 4 and 273.15 K and the error bars represent $\pm 2\sigma$ values.

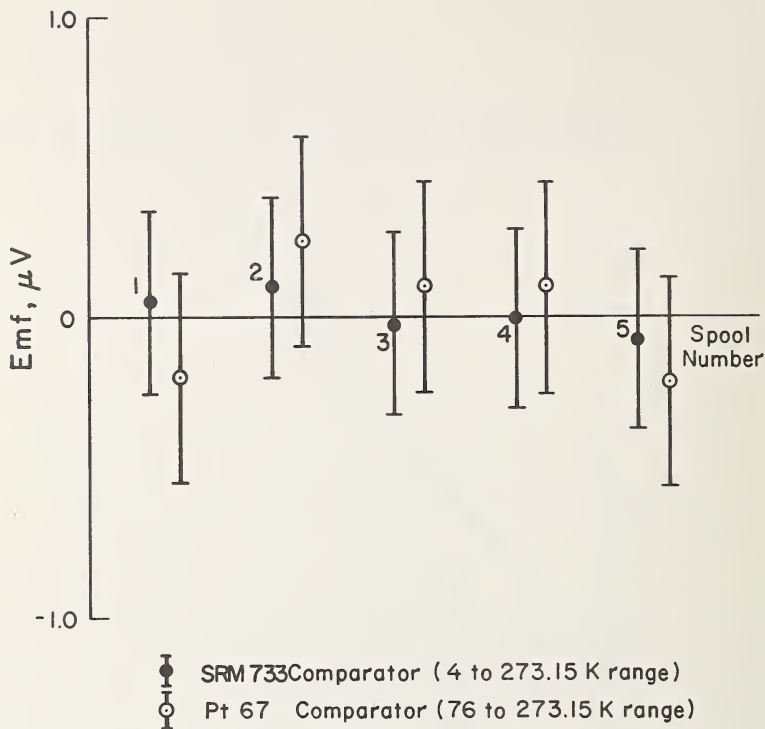



Figure 5. Thermoelectric intercomparisons of SRM 733 wire from each of the five stock spools. Intercomparisons were made with respect to a SRM 733 comparator between 4 and 273.15 K and a Pt-67 versus SRM 733 values have been normalized to show only the spool-to-spool variations. The error bars represent $\pm 2\sigma$ values.

 = Thermal Anchor

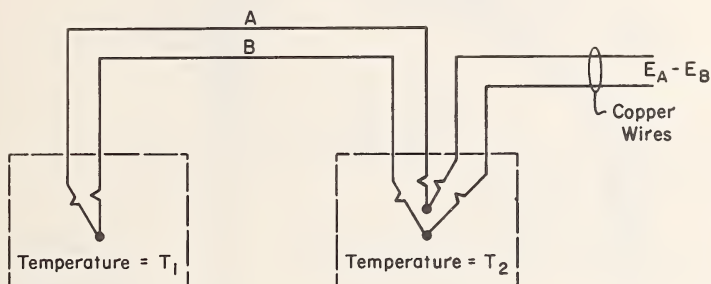

FIGURE 6a - TYPICAL THERMOCOUPLE ARRANGEMENT

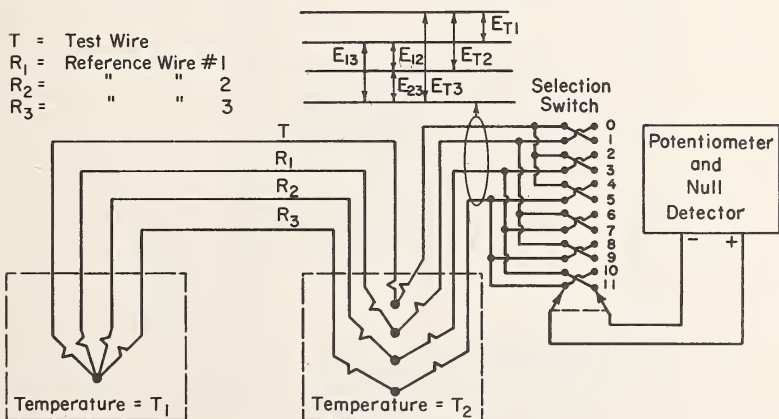

FIGURE 6b - COMPARATOR CIRCUIT for CALIBRATION of STANDARD REFERENCE THERMOCOUPLE WIRES

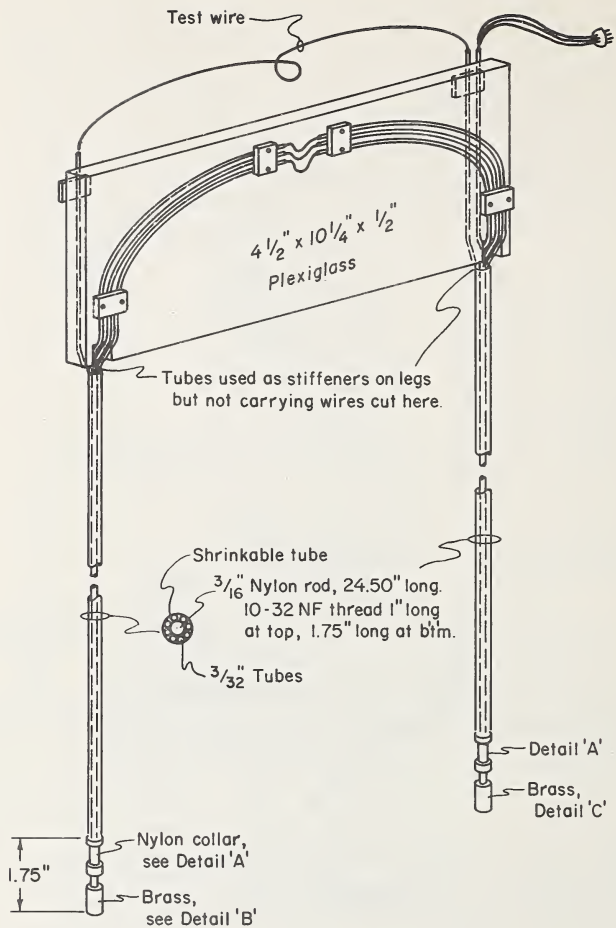
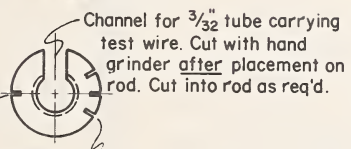
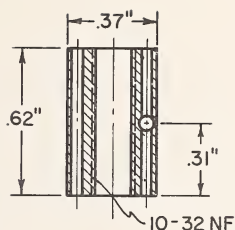
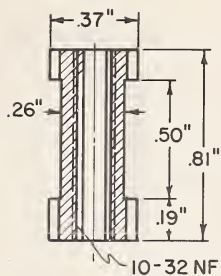
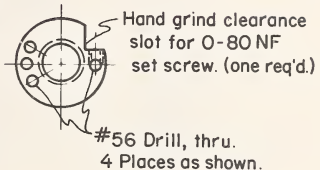

Figure 7a. Details of comparator construction (pictorial view).



Hand grind notches for wires after placement on rod.



DETAIL 'A'

DETAIL 'B'

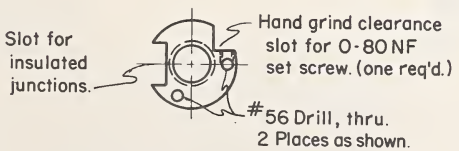
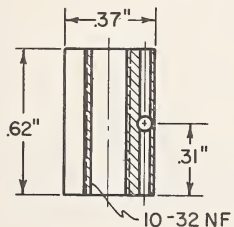

DETAIL 'C'

Figure 7b. Details of comparator construction (junction terminal blocks).

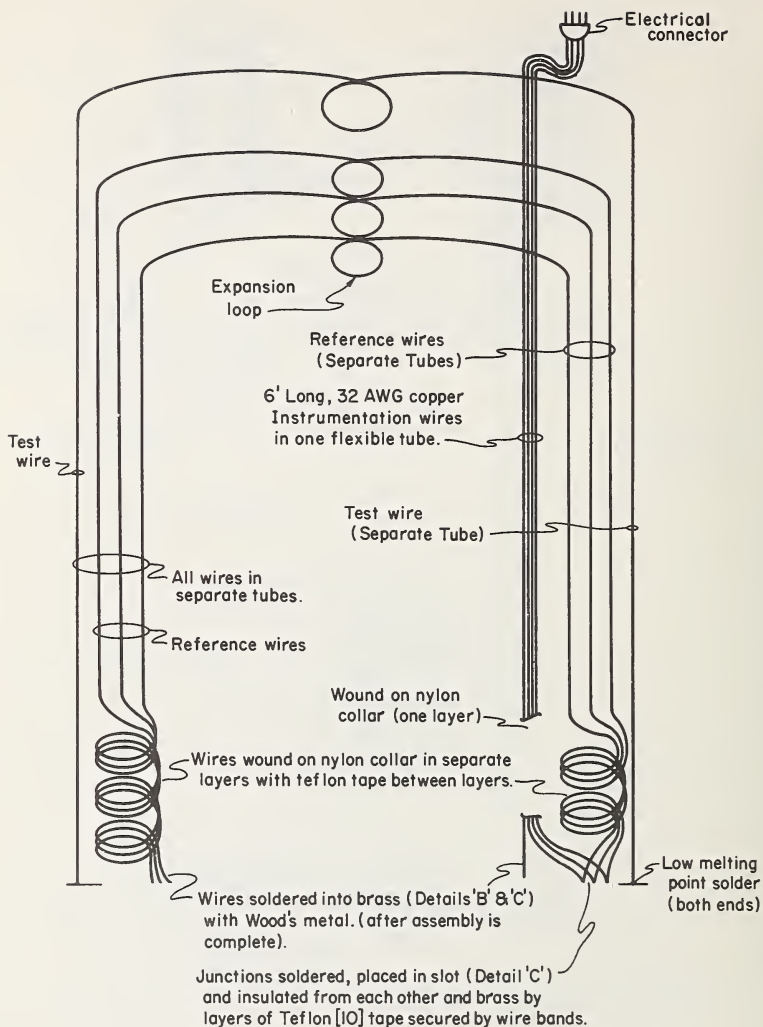

Figure 7c. Details of comparator construction (wiring diagram).

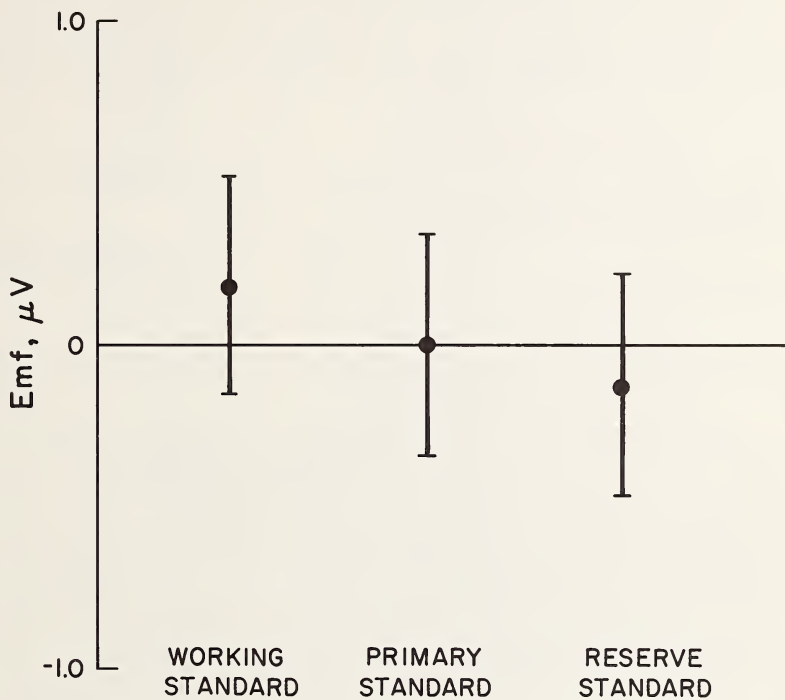

Figure 8. Intercomparison of three SRM 733 thermocouple comparators via a common thermocouple wire. The error bars represent $\pm 2\sigma$ values.

U.S. DEPT. OF COMM. BIBLIOGRAPHIC DATA SHEET	1. PUBLICATION OR REPORT NO. NBS SP 260-34	2. Gov't Accession No.	3. Recipient's Accession No.
4. TITLE AND SUBTITLE Thermoelectric Voltage of Silver - 28 Atomic Percent Gold Thermocouple Wire, SRM 733, Versus Common Thermocouple Materials (Between Liquid Helium and Ice Fixed Points)		5. Publication Date March 1972	6. Performing Organization Code
7. AUTHOR(S) L. L. Sparks and J. G. Hust		8. Performing Organization	
9. PERFORMING ORGANIZATION NAME AND ADDRESS NATIONAL BUREAU OF STANDARDS DEPARTMENT OF COMMERCE Boulder, Colorado 80302		10. Project/Task/Work Unit No. Project 2752759	11. Contract/Grant No. NBS-OSRM
12. Sponsoring Organization Name and Address National Bureau of Standards Office of Standard Reference Materials (NBS-OSRM) Washington, D. C.		13. Type of Report & Period Covered Final	14. Sponsoring Agency Code
15. SUPPLEMENTARY NOTES			
<p>16. ABSTRACT (A 200-word or less factual summary of most significant information. If document includes a significant bibliography or literature survey, mention it here.)</p> <p>Industry wide standardization of thermocouple wire depends, in part, on the ability to thermoelectrically compare commercial wires with a Standard Reference Material (SRM). The alloy <u>Ag</u> - 28 at % Au, SRM 733, meets the requirements of a thermoelectric reference material, particularly in the temperature range of liquid helium and liquid hydrogen where Pt-67 is not adequate. Thermoelectric voltage comparisons are reported for SRM 733 versus common thermocouple materials between liquid helium and ice fixed points. Detailed standard reference data based on these common materials are given in NBS Monograph 124. The comparisons were made in a thermocouple comparator which was designed to be a permanent holder of three SRM 733 wires; the comparator allows tests to be made without handling the standard wires. Details of the construction, testing, and analysis of the comparators are given.</p>			
17. KEY WORDS (Alphabetical order, separated by semicolons) Cryogenics; Seebeck voltage; silver-gold alloy; standard reference material; thermocouple.			
18. AVAILABILITY STATEMENT <input checked="" type="checkbox"/> UNLIMITED. <input type="checkbox"/> FOR OFFICIAL DISTRIBUTION. DO NOT RELEASE TO NTIS.		19. SECURITY CLASS (THIS REPORT) UNCLASSIFIED	21. NO. OF PAGES 34
		20. SECURITY CLASS (THIS PAGE) UNCLASSIFIED	22. Price 40¢

NBS TECHNICAL PUBLICATIONS

PERIODICALS

JOURNAL OF RESEARCH reports National Bureau of Standards research and development in physics, mathematics, chemistry, and engineering. Comprehensive scientific papers give complete details of the work, including laboratory data, experimental procedures, and theoretical and mathematical analyses. Illustrated with photographs, drawings, and charts.

Published in three sections, available separately:

• Physics and Chemistry

Papers of interest primarily to scientists working in these fields. This section covers a broad range of physical and chemical research, with major emphasis on standards of physical measurement, fundamental constants, and properties of matter. Issued six times a year. Annual subscription: Domestic, \$9.50; \$2.25 additional for foreign mailing.

• Mathematical Sciences

Studies and compilations designed mainly for the mathematician and theoretical physicist. Topics in mathematical statistics, theory of experiment design, numerical analysis, theoretical physics and chemistry, logical design and programming of computers and computer systems. Short numerical tables. Issued quarterly. Annual subscription: Domestic, \$5.00; \$1.25 additional for foreign mailing.

• Engineering and Instrumentation

Reporting results of interest chiefly to the engineer and the applied scientist. This section includes many of the new developments in instrumentation resulting from the Bureau's work in physical measurement, data processing, and development of test methods. It will also cover some of the work in acoustics, applied mechanics, building research, and cryogenic engineering. Issued quarterly. Annual subscription: Domestic, \$5.00; \$1.25 additional for foreign mailing.

TECHNICAL NEWS BULLETIN

The best single source of information concerning the Bureau's research, developmental, cooperative, and publication activities, this monthly publication is designed for the industry-oriented individual whose daily work involves intimate contact with science and technology—for engineers, chemists, physicists, research managers, product-development managers, and company executives. Annual subscription: Domestic, \$3.00; \$1.00 additional for foreign mailing.

NONPERIODICALS

Applied Mathematics Series. Mathematical tables, manuals, and studies.

Building Science Series. Research results, test methods, and performance criteria of building materials, components, systems, and structures.

Handbooks. Recommended codes of engineering and industrial practice (including safety codes) developed in cooperation with interested industries, professional organizations, and regulatory bodies.

Special Publications. Proceedings of NBS conferences, bibliographies, annual reports, wall charts, pamphlets, etc.

Monographs. Major contributions to the technical literature on various subjects related to the Bureau's scientific and technical activities.

National Standard Reference Data Series. NSRDS provides quantitative data on the physical and chemical properties of materials, compiled from the world's literature and critically evaluated.

Product Standards. Provide requirements for sizes, types, quality, and methods for testing various industrial products. These standards are developed cooperatively with interested Government and industry groups and provide the basis for common understanding of product characteristics for both buyers and sellers. Their use is voluntary.

Technical Notes. This series consists of communications and reports (covering both other agency and NBS-sponsored work) of limited or transitory interest.

Federal Information Processing Standards Publications. This series is the official publication within the Federal Government for information on standards adopted and promulgated under the Public Law 89-306, and Bureau of the Budget Circular A-86 entitled, Standardization of Data Elements and Codes in Data Systems.

Consumer Information Series. Practical information, based on NBS research and experience, covering areas of interest to the consumer. Easily understandable language and illustrations provide useful background knowledge for shopping in today's technological marketplace.

NBS Special Publication 305, Supplement 1, Publications of the NBS, 1968-1969. When ordering, include Catalog No. C13.10:305. Price \$4.50; \$1.25 additional for foreign mailing.

Order NBS publications from:

Superintendent of Documents
Government Printing Office
Washington, D.C. 20402

U.S. DEPARTMENT OF COMMERCE
National Bureau of Standards
Washington, O.C. 20234

OFFICIAL BUSINESS

Penalty for Private Use, \$300

POSTAGE AND FEES PAID
U.S. DEPARTMENT OF COMMERCE

