

# VERITAS Volume Manager™ 3.1.1

---

## Administrator's Guide

Solaris

February 2001  
30-000226-011

  
VERITAS

---

## Disclaimer

The information contained in this publication is subject to change without notice. VERITAS Software Corporation makes no warranty of any kind with regard to this manual, including, but not limited to, the implied warranties of merchantability and fitness for a particular purpose. VERITAS Software Corporation shall not be liable for errors contained herein or for incidental or consequential damages in connection with the furnishing, performance, or use of this manual.

## Copyright

Copyright © 2000-2001 VERITAS Software Corporation. All rights reserved. VERITAS is a registered trademark of VERITAS Software Corporation in the US and other countries. The VERITAS logo and VERITAS Volume Manager are trademarks of VERITAS Software Corporation. All other trademarks or registered trademarks are the property of their respective owners.

Printed in the USA, February 2001.

VERITAS Software Corporation  
1600 Plymouth St.  
Mountain View, CA 94043  
Phone 650-335-8000  
Fax 650-335-8050  
[www.veritas.com](http://www.veritas.com)



# Contents

---

<b>Preface</b> .....	<b>xiii</b>
Introduction .....	xiii
Audience .....	xiii
Scope .....	xiii
Organization .....	xiv
Using This Guide .....	xiv
Related Documents .....	xv
Conventions .....	xvi
Getting Help .....	xvii
Downloading and Running VRTSexplorer .....	xviii
<b>Chapter 1. Understanding VERITAS Volume Manager</b> .....	<b>1</b>
Introduction .....	1
VxVM and the Operating System .....	2
How Data is Stored .....	2
How VxVM Handles Storage Management .....	3
Physical Objects—Physical Disks .....	3
Disk Arrays .....	4
Multipathed Disk Arrays .....	5
Virtual Objects .....	6
Combining Virtual Objects in VxVM .....	10
Volume Layouts in VxVM .....	11
Implementation of Layered Volumes .....	12
Layout Methods .....	12



---

Concatenation and Spanning .....	13
Striping (RAID-0) in VxVM .....	15
Mirroring (RAID-1) in VxVM .....	18
Striping Plus Mirroring (Mirrored-Stripe or RAID-0+1) .....	19
Mirroring Plus Striping (Striped-Mirror, RAID-1+0 or RAID-10) .....	20
RAID-5 in VxVM .....	22
Layered Volumes .....	27
Online Relayout .....	28
How Online Relayout Works .....	29
Permitted Transformations .....	30
Transformation Characteristics .....	33
Transformations and Volume Length .....	34
Volume Resynchronization .....	34
Dirty Flags .....	35
Resynchronization Process .....	35
Dirty Region Logging (DRL) .....	35
Dirty Region Logs .....	36
<i>Log subdisks</i> .....	36
Dirty Bits .....	36
Sequential DRL .....	36
FastResync (FR) and Snapshots .....	37
FastResync Enhancements .....	37
The Enhanced Snapshot Model .....	38
How FastResync Works with Snapshots .....	39
Additional Snapshot Features .....	40
FastResync Limitations .....	41
VxSmartSync Recovery Accelerator .....	41
Data Volume Configuration .....	42
Redo Log Volume Configuration .....	42
Hot-Relocation .....	42



---

<b>Chapter 2. Administering Disks</b> .....	<b>43</b>
Introduction .....	43
Disk Devices .....	43
Placing Disks Under VxVM Control .....	44
Installing and Formatting the Disk Media .....	45
Adding a Disk to VxVM .....	46
Reinitializing a Disk .....	50
Using vxdiskadd to Place a Disk Under Control of VxVM .....	51
Rootability .....	51
Booting root Volumes .....	52
Boot-time Volume Restrictions .....	52
Encapsulating a Disk for Use in VxVM .....	53
Failure of Disk Encapsulation .....	56
Encapsulating and Mirroring the root Disk .....	56
Using vxdisk for Encapsulation .....	58
Using RAM Disks with VxVM .....	59
Removing Disks .....	60
Removing a Disk with Subdisks .....	61
Removing a Disk with No Subdisks .....	62
Removing and Replacing Disks .....	63
Replacing a Failed or Removed Disk .....	65
Enabling a Physical Disk .....	66
Taking a Disk Offline .....	67
Renaming a Disk .....	68
Reserving Disks .....	68
Displaying Disk Information .....	69
Displaying Multipaths to a VM Disk .....	69
Displaying Disk Information with vxdiskadm .....	71
Prevent Multipathing/Suppress Devices from VxVM's View .....	71
Allow Multipathing/Unsuppress Devices from VxVM's View .....	77



---

<b>Chapter 3. Creating and Administering Disk Groups</b> .....	<b>83</b>
Introduction .....	83
Specifying a Disk Group to Commands .....	84
Creating a Disk Group .....	84
Adding a Disk to a Disk Group .....	85
Removing a Disk from a Disk Group .....	86
Deporting a Disk Group .....	87
Importing a Disk Group .....	88
Renaming a Disk Group .....	90
Moving Disks between Disk Groups .....	91
Moving Disk Groups Between Systems .....	92
Reserving Minor Numbers for Disk Groups .....	94
Disabling a Disk Group .....	94
Destroying a Disk Group .....	95
Displaying Disk Group Information .....	95
Displaying Free Space in a Disk Group .....	96
Upgrading a Disk Group .....	97
Managing the Configuration Daemon in VxVM .....	99
<b>Chapter 4. Creating and Administering Subdisks</b> .....	<b>101</b>
Introduction .....	101
Creating Subdisks .....	101
Displaying Subdisk Information .....	102
Moving Subdisks .....	102
Splitting Subdisks .....	103
Joining Subdisks .....	103
Associating Subdisks with Plexes .....	104
Associating Log Subdisks .....	105
Dissociating Subdisks from Plexes .....	106
Removing Subdisks .....	106



Changing Subdisk Attributes .....	107
<b>Chapter 5. Creating and Administering Plexes .....</b>	<b>109</b>
Introduction .....	109
Creating Plexes .....	109
Creating a Striped Plex .....	110
Displaying Plex Information .....	110
Plex States .....	110
Plex Condition Flags .....	113
Plex Kernel States .....	114
Attaching and Associating Plexes .....	115
Taking Plexes Offline .....	115
Detaching Plexes .....	116
Reattaching Plexes .....	116
Moving Plexes .....	117
Copying Plexes .....	118
Dissociating and Removing Plexes .....	118
Changing Plex Attributes .....	119
<b>Chapter 6. Creating Volumes .....</b>	<b>121</b>
Introduction .....	121
Types of Volume Layouts .....	121
Creating a Volume .....	123
Advanced Approach .....	123
Assisted Approach .....	123
Using vxassist .....	124
Setting Default Values for vxassist .....	125
Discovering the Maximum Size of a Volume .....	127
Creating a Volume on Any Disk .....	127
Creating a Volume on Specific Disks .....	128
Creating a Mirrored Volume .....	129



Creating a Mirrored-Concatenated Volume .....	129
Creating a Concatenated-Mirror Volume .....	129
Creating a Mirrored Volume with Logging Enabled .....	130
Creating a Striped Volume .....	130
Creating a Mirrored-Stripe Volume .....	131
Creating a Striped-Mirror Volume .....	131
Mirroring across Targets or Controllers .....	132
Creating a RAID-5 Volume .....	132
Creating a Volume using vxmake .....	133
Creating a Volume Using a vxmake Description File .....	135
Initializing a Volume .....	136
Accessing a Volume .....	136
<b>Chapter 7. Administering Volumes .....</b>	<b>137</b>
Introduction .....	137
Displaying Volume Information .....	137
Volume States .....	138
Volume Kernel States .....	140
Monitoring and Controlling Tasks .....	140
Specifying Task Tags .....	140
Managing Tasks with vxtask .....	141
Stopping a Volume .....	143
Putting a Volume in Maintenance Mode .....	143
Starting a Volume .....	144
Adding a Mirror to a Volume .....	144
Mirroring All Volumes .....	145
Mirroring Volumes on a VM Disk .....	145
Removing a Mirror .....	146
Adding a DRL Log to a Mirrored Volume .....	147
Removing a DRL Log .....	147





Adding a RAID-5 Log .....	148
Adding a RAID-5 Log using vxplex .....	148
Removing a RAID-5 Log .....	148
Resizing a Volume .....	149
Resizing Volumes using vxresize .....	150
Resizing Volumes using vxassist .....	151
Resizing Volumes using vxvol .....	152
Changing the Read Policy for Mirrored Volumes .....	153
Removing a Volume .....	154
Moving Volumes from a VM Disk .....	155
Enabling FastResync on a Volume .....	156
Disabling FastResync .....	157
Backing up Volumes Online .....	157
Backing Up Volumes Online Using Mirrors .....	157
Backing Up Volumes Online Using Snapshots .....	159
Backing Up Multiple Volumes Using Snapshots .....	161
Merging a Snapshot Volume (snapback) .....	161
Dissociating a Snapshot Volume .....	162
Displaying Snapshot Information .....	162
Performing Online Relayout .....	163
Specifying a Non-Default Layout .....	163
Specifying a Plex for Relayout .....	164
Tagging a Relayout Operation .....	164
Viewing the Status of a Relayout .....	164
Controlling the Progress of a Relayout .....	165
Converting Between Layered and Non-Layered Volumes .....	166
<b>Chapter 8. Administering Hot-Relocation .....</b>	<b>167</b>
Introduction .....	167
How Hot-Relocation works .....	168



Partial Disk Failure Mail Messages .....	169
Complete Disk Failure Mail Messages .....	170
How Space is Chosen for Relocation .....	171
Configuring a System for Hot-Relocation .....	172
Displaying Spare Disk Information .....	173
Marking a Disk as a Hot-Relocation Spare .....	173
Removing a Disk from Use as a Hot-Relocation Spare .....	174
Excluding a Disk from Hot-Relocation Use .....	175
Making a Disk Available for Hot-Relocation Use .....	175
Moving and Unrelocating Subdisks .....	176
Moving and Unrelocating Subdisks using vxdiskadm .....	177
Moving and Unrelocating subdisks using vxassist .....	178
Moving and Unrelocating Subdisks using vxunreloc .....	179
Restarting vxunreloc After Errors .....	181
Modifying the Behavior of Hot-Relocation .....	181
<b>Chapter 9. Dynamic Multipathing (DMP) .....</b>	<b>183</b>
Introduction .....	183
Disk Arrays Supported .....	184
Co-existence with drivers .....	184
SENA Device Support .....	184
Dynamic Reconfiguration .....	185
Path Failover Mechanism .....	185
Load Balancing .....	185
Bootting From DMP Devices .....	186
Enabling and Disabling Input/Output (I/O) Controllers .....	186
Displaying DMP Database Information .....	186
Administrative Tasks .....	187
Disable Multipathing .....	191



---

<b>Chapter 10. Cluster Functionality</b> .....	<b>193</b>
Introduction .....	193
Cluster Functionality Overview .....	193
Shared VxVM Objects .....	194
Limitations of Shared Disk Groups in VxVM .....	195
How Cluster Volume Management Works .....	195
Disk Status Resolution in Clusters .....	201
Disk Group Activation .....	201
Dirty Region Logging (DRL) and Cluster Environments .....	202
Log Format and Size .....	203
Compatibility .....	203
How DRL Works in a Cluster Environment .....	204
Upgrading Cluster Functionality .....	205
FastResync and Cluster Environments .....	206
Administering VxVM in Cluster Environments .....	208
Determining if a Disk is Shareable .....	208
Creating a Shared Disk Group .....	208
Setting the Connectivity Policy on a Shared Disk Group .....	209
Changing the Activation Mode on a Shared Disk Group .....	209
Importing Disk Groups as Shared .....	209
Converting a Disk Group from Shared to Private .....	209
Forcibly Importing a Disk Group or Adding a Disk .....	210
Listing Shared Disk Groups .....	210
Creating Volumes with Exclusive Open Access by a Node .....	211
Setting Exclusive Open Access to a Volume by a Node .....	211
Other Cluster-related Utilities and Daemons .....	212
vxclust Utility .....	212
vxclustadm Utility .....	213
vxconfigd Daemon .....	213
vxdctl Utility .....	215



---

vxrecover Utility .....	216
vxstat Utility .....	217
<b>Chapter 11. Performance Monitoring and Tuning .....</b>	<b>219</b>
Introduction .....	219
Performance Guidelines .....	219
Data Assignment .....	219
Striping .....	220
Mirroring .....	220
Combining Mirroring and Striping .....	221
RAID-5 .....	221
Volume Read Policies .....	221
Performance Monitoring .....	223
Setting Performance Priorities .....	223
Obtaining Performance Data .....	223
Using Performance Data .....	225
Tuning VxVM .....	228
General Tuning Guidelines .....	228
Tuning for Large Systems .....	228
Changing Values of Tunables .....	229
Tunables .....	230
<b>Appendix A. Commands Summary .....</b>	<b>237</b>
<b>Glossary .....</b>	<b>247</b>
<b>Index .....</b>	<b>259</b>



# Preface

---

## Introduction

The *VERITAS Volume Manager™ Administrator's Guide* provides information on how to use VERITAS Volume Manager (VxVM) and all of its features.

## Audience

This guide is intended for system administrators responsible for installing, configuring, and maintaining systems under the control of VxVM.

This guide assumes that the user has a:

- ◆ working knowledge of the UNIX operating system
- ◆ basic understanding of UNIX system administration
- ◆ basic understanding of volume management

## Scope

The purpose of this guide is to provide the system administrator with a thorough knowledge of the procedures and concepts involved with volume management and system administration using VxVM. This guide includes guidelines on how to take advantage of various advanced VxVM features, and instructions on how to use VxVM commands to create and manipulate objects in VxVM.



## Organization

This guide is organized as follows:

- ◆ [Understanding VERITAS Volume Manager](#)
- ◆ [Administering Disks](#)
- ◆ [Creating and Administering Disk Groups](#)
- ◆ [Creating and Administering Subdisks](#)
- ◆ [Creating and Administering Plexes](#)
- ◆ [Creating Volumes](#)
- ◆ [Administering Volumes](#)
- ◆ [Administering Hot-Relocation](#)
- ◆ [Dynamic Multipathing \(DMP\)](#)
- ◆ [Cluster Functionality](#)
- ◆ [Performance Monitoring and Tuning](#)

## Using This Guide

This guide contains instructions for performing VxVM system administration tasks. VxVM administration functions can be performed through one or more of the following interfaces:

- ◆ a set of complex commands
- ◆ a single automated command (`vxassist`)
- ◆ a menu-driven interface (`vxdiskadm`)
- ◆ the Storage Administrator (graphical user interface)

This guide describes how to use the various VxVM command line interfaces for administering VxVM. Details on how to use the Storage Administrator graphical user interface can be found in the *VERITAS Volume Manager Storage Administrator Administrator's Guide*. Detailed descriptions of the VxVM commands and utilities, their options, and details on their use are located in the VxVM manual pages. Also see “[Commands Summary](#)” on page 237 for a listing of the commonly used commands in VxVM together with references to their descriptions.

---

**Note** Most VxVM commands require superuser or other appropriate privileges.

---

## Related Documents

The following documents provide information related to VxVM:

- ◆ *VERITAS Volume Manager Installation Guide*
- ◆ *VERITAS Volume Manager Release Notes*
- ◆ *VERITAS Volume Manager Hardware Notes*
- ◆ *VERITAS Volume Manager Troubleshooting Guide*
- ◆ *VERITAS Volume Manager Storage Administrator Administrator's Guide*
- ◆ VERITAS Volume Manager manual pages



## Conventions

The following table describes the typographic conventions used in this guide.

Typeface	Usage	Examples
monospace	Computer output, file contents, files, directories, software elements such as command options, function names, and parameters	Read tunables from the <code>/etc/vx/tunefstab</code> file. See the <code>ls(1)</code> manual page for more information.
<i>italic</i>	New terms, book titles, emphasis, variables to be replaced by a name or value	See the <i>User's Guide</i> for details. The variable <code>ncsize</code> determines the value of...
<b>monospace (bold)</b>	User input; the “#” symbol indicates a command prompt	<code># mount -F vxfs /h/filesys</code>
<b><i>monospace (bold and italic)</i></b>	Variables to be replaced by a name or value in user input	<code># mount -F <i>fstype mount_point</i></code>

Symbol	Usage	Examples
%	C shell prompt	
\$	Bourne/Korn/Bash shell prompt	
#	Superuser prompt (all shells)	
\	Continued input on the following line	<code># mount -F vxfs \ /h/filesys</code>
[]	In a command synopsis, brackets indicates an optional argument	<code>ls [-a]</code>
	In a command synopsis, a vertical bar separates mutually exclusive arguments	<code>mount [suid   nosuid]</code>



## Getting Help

For information about VERITAS® service packages, contact VERITAS Customer Support:

US Customers: 1-800-342-0652

International Customers: +1-650-335-8555

Fax: 1-650-335-8428

Email: [support@veritas.com](mailto:support@veritas.com)

For license information:

Phone: 1-650-318-4265

Email: [license@veritas.com](mailto:license@veritas.com)

Fax: 1-650-335-8428

For software updates:

Phone: 1-650-526-2549

Email: [swupdate@veritas.com](mailto:swupdate@veritas.com)

For additional information about VERITAS and VERITAS products, visit the WEB site at:

[www.veritas.com](http://www.veritas.com)

For additional information about the Knowledge Base and Technical Notes & Alerts, visit the Technical Support Web Site:

[www.support.veritas.com](http://www.support.veritas.com)



## Downloading and Running VRTSexplorer

If you have access to the Internet, you can use the `VRTSexplorer` program to assist Customer Support in diagnosing the cause of your problem as follows:

1. Use a web browser or the `ftp` program to download the `VRTSexplorer` program at the following URL:

```
ftp://ftp.veritas.com/pub/support/vxexplore.tar.Z
```

Save the file to a temporary directory such as `/tmp` as shown in these instructions. If you download the file to a different directory, substitute its pathname for `/tmp` throughout.

2. Log in as `root` on the affected system, and use the following commands to extract the contents of the downloaded file to the directory `/tmp/VRTSexplorer`:

```
# cd /tmp
# zcat vxexplore.tar.Z | tar xvf -
```

3. Run the `VRTSexplorer` program located in the `VRTSexplorer` directory by entering the following command:

```
# /tmp/VRTSexplorer/VRTSexplorer
```

4. When `VRTSexplorer` prompts you for a destination directory for the information that it collects, press `Return` to accept the default directory `/tmp`, or enter a pathname of your own choice. `VRTSexplorer` writes the results of its investigations to a compressed tar file named `VRTSexplorer.hostid.tar.Z` in the specified directory.
5. Use the file upload facility of your web browser or the `ftp` program to transfer the file output by `VRTSexplorer` to the VERITAS Customer Support anonymous FTP site:

```
ftp://ftp.veritas.com/incoming
```

6. Call VERITAS Customer Support on 1-800-342-0652, inform them that you have run `VRTSexplorer` and tell them the name of the file that you transferred to the FTP site.

Alternatively, if you have already been assigned a call ID number by Customer Support, e-mail [support@veritas.com](mailto:support@veritas.com) including your case ID number in the subject line.

For more information about the `VRTSexplorer` program, consult the `README` file located in the `VRTSexplorer` directory.

## Introduction

VERITAS Volume Manager (VxVM) is a storage management subsystem that allows you to manage physical disks as logical devices called *volumes*. A volume is a logical device that appears to data management systems as a physical disk partition device.

VxVM provides easy-to-use online disk storage management for computing environments and Storage Area Network (SAN) environments. Through support of Redundant Array of Independent Disks (RAID), VxVM protects against disk and hardware failure. Additionally, VxVM provides features that enable fault tolerance and fast recovery from disk failure.

VxVM overcomes physical restrictions imposed by hardware disk devices by providing a logical volume management layer. This allows volumes to span multiple disks.

VxVM provides the tools to improve performance and ensure data availability and integrity. VxVM also dynamically configures disk storage while the system is active.

This chapter explains VxVM in terms of these fundamental concepts:

- ◆ [How VxVM Handles Storage Management](#)
- ◆ [Physical Objects—Physical Disks](#)
- ◆ [Virtual Objects](#)
- ◆ [Volume Layouts in VxVM](#)

In addition to the basic concepts, the descriptions of the following advanced concepts will enable you to gain the maximum benefit from VxVM:

- ◆ [Online Relayout](#)
- ◆ [Volume Resynchronization](#)
- ◆ [Dirty Region Logging \(DRL\)](#)
- ◆ [FastResync \(FR\) and Snapshots](#)
- ◆ [VxSmartSync Recovery Accelerator](#)
- ◆ [Hot-Relocation](#)



## VxVM and the Operating System

VxVM operates as a subsystem between your operating system and your data management systems, such as file systems and database management systems. VxVM is tightly coupled with the operating system. Before a disk can be brought under VxVM control, the disk must be accessible through the operating system device interface. VxVM is layered on top of the operating system interface services, and is dependent upon how the operating system accesses physical disks.

VxVM is dependent upon the operating system for the following functionality:

- ◆ operating system (disk) devices
- ◆ device handles
- ◆ VM disks
- ◆ VxVM dynamic multipathing (DMP) metadvice

This guide introduces you to the VxVM commands which are used to carry out the tasks associated with VxVM objects. These commands are described on the relevant manual pages and in the chapters of this guide when VxVM tasks are described.

VxVM relies on the following constantly running daemons for its operation:

- ◆ `vxconfigd`—The VxVM configuration daemon maintains disk and group configurations and communicates configuration changes to the kernel, and modifies configuration information stored on disks.
- ◆ `vxiod`—The VxVM I/O daemon provides extended I/O operations without blocking calling processes. Several `vxiod` daemons are usually started at boot time, and continue to run at all times.
- ◆ `vxrelocd`—The hot-relocation daemon monitors VxVM for events that affect redundancy, and performs hot-relocation to restore redundancy.

## How Data is Stored

There are several methods used to store data on physical disks. These methods organize data on the disk so the data can be stored and retrieved efficiently. The basic method of disk organization is called *formatting*. Formatting prepares the hard disk so that files can be written to and retrieved from the disk by using a prearranged storage pattern.

Hard disks are formatted, and information stored, using two methods: physical-storage layout and logical-storage layout. VxVM uses the *logical-storage layout* method. The types of storage layout supported by VxVM are introduced in this chapter.



## How VxVM Handles Storage Management

VxVM uses two types of *objects* to handle storage management: *physical objects* and *virtual objects*.

- ◆ Physical objects—Physical disks or other hardware with block and raw device interfaces that are used to store data.
- ◆ Virtual objects—When one or more physical disks are brought under the control of VxVM, it creates virtual objects called *volumes* on those physical disks. Each volume records and retrieves data from one or more physical disks. Volumes are accessed by file systems, databases, or other applications in the same way that physical disks are accessed. Volumes are also composed of other virtual objects (volumes, subdisks, disk groups, VM disks) that are used in changing the volume configuration. Volumes and their virtual components are called virtual objects or VxVM objects.

### Physical Objects—Physical Disks

A *physical disk* is the basic storage device (media) where the data is ultimately stored. You can access the data on a physical disk by using a *device name* to locate the disk. The physical disk device name varies with the computer system you use. Not all parameters are used on all systems. Typical device names are of the form `c#t#d#s#`, where:

- ◆ `c#` specifies the controller
- ◆ `t#` specifies the target ID
- ◆ `d#` specifies the disk
- ◆ `s#` specifies the partition or slice

The figure, “[Physical Disk Example](#)”, shows how a physical disk and device name (*devname*) are illustrated in this document. For example, device name `c0t0d0s2` is the entire hard disk connected to controller number 0 in the system, with a target ID of 0, and physical disk number 0.

Physical Disk Example

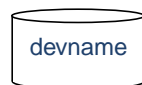

VxVM writes identification information on physical disks under VxVM control (VM disks). VxVM disks can be identified even after physical disk disconnection or system outages. VxVM can then re-form disk groups and logical objects to provide failure detection and to speed system recovery.



## Partitions

A physical disk can be divided into one or more *partitions*, also known as *slices*. The *partition number* is added at the end of the devname, and is denoted by  $s\#$ . Note that partition  $s2$  refers to an entire physical disk. See the partition shown in “[Partition Example](#).”

Partition Example

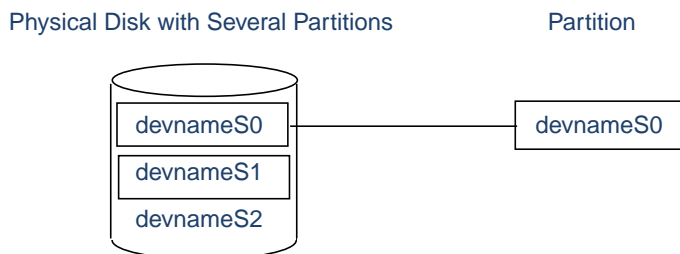

## Disk Arrays

Performing I/O to disks is a relatively slow process because disks are physical devices that require time to move the heads to the correct position on the disk before reading or writing. If all of the read or write operations are done to individual disks, one at a time, the read-write time can become unmanageable. Performing these operations on multiple disks can help to reduce this problem.

A *disk array* is a collection of physical disks that VxVM can represent to the operating system as one or more virtual disks or volumes. The volumes created by VxVM look and act to the operating system like physical disks. Applications that interact with volumes should work in the same way as with physical disks.

“[How VxVM presents a Disk Array as Volumes to the Operating System](#)” shows how VxVM represents a disk array as several volumes to the operating system

How VxVM presents a Disk Array as Volumes to the Operating System

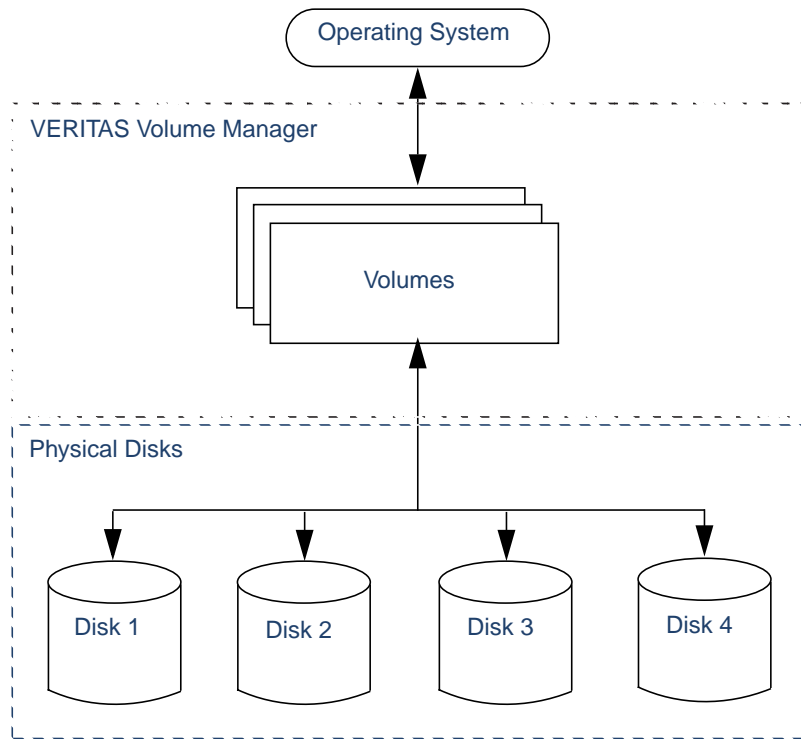

Data can be spread across several disks within an array to distribute or *balance* I/O operations across the disks. Using parallel I/O across multiple disks in this way improves I/O performance by increasing data transfer speed and overall throughput for the array.

## Multipathed Disk Arrays

Some disk arrays provide multiple ports to access their disk devices. These ports, coupled with the host bus adaptor (HBA) controller and any data bus or I/O processor local to the array, make up multiple hardware paths to access the disk devices. Such disk arrays are called *multipathed disk arrays*. This type of disk array can be connected to host systems in many different configurations, (such as multiple ports connected to different controllers on a single host, chaining of the ports through a single controller on a host, or ports connected to different hosts simultaneously). For more detailed information, see “[Dynamic Multipathing \(DMP\)](#)” on page 183.



## Virtual Objects

Virtual objects in VxVM include the following:

- ◆ VM disks
- ◆ disk groups
- ◆ subdisks
- ◆ plexes
- ◆ volumes

The connection between physical objects and VxVM objects is made when you place a physical disk under VxVM control.

After installing VxVM on a host system, you must bring the contents of physical disks under VxVM control by collecting the VM disks into disk groups and allocating the disk group space to create logical volumes.

Bringing the contents of physical disks under VxVM control is accomplished only if VxVM takes control of the physical disks and the disk is not under control of another storage manager.

VxVM creates virtual objects and makes logical connections between the objects. The virtual objects are then used by VxVM to do storage management tasks.

---

**Note** The `vxprint` command displays detailed information on existing VxVM objects. For additional information on the `vxprint` command, see “[Displaying Volume Information](#)” on page 137 and the `vxprint(1M)` manual page.

---

## VM Disks

When you place a physical disk under VxVM control, a VM disk is assigned to the physical disk. A VM disk is under VxVM control and is usually in a disk group. Each VM disk corresponds to at least one physical disk. VxVM allocates storage from a contiguous area of VxVM disk space.

A VM disk typically includes a *public region* (allocated storage) and a *private region* where VxVM internal configuration information is stored.

Each VM disk has a unique *disk media name* (a virtual disk name). You can either supply the disk name, or allow VxVM to assign a default name that typically takes the form `disk##`. “[VM Disk Example](#)” shows a VM disk with a media name of `disk01` that is assigned to the physical disk *devname*.



VM Disk Example

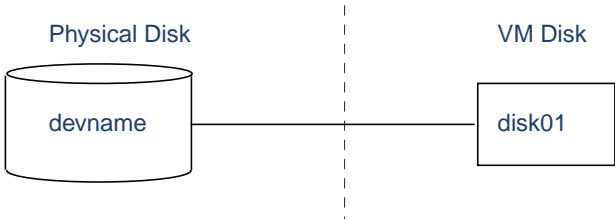

Disk Groups

A *disk group* is a collection of VM disks that share a common configuration. A disk group configuration is a set of records with detailed information about related VxVM objects, their attributes, and their connections. The default disk group is `rootdg` (the root disk group).

You can create additional disk groups as necessary. Disk groups allow you to group disks into logical collections. A disk group and its components can be moved as a unit from one host machine to another.

Volumes are created within a disk group. A given volume must be configured from disks in the same disk group.

Subdisks

A *subdisk* is a set of contiguous disk blocks. A block is a unit of space on the disk. VxVM allocates disk space using subdisks. A VM disk can be divided into one or more subdisks. Each subdisk represents a specific portion of a VM disk, which is mapped to a specific region of a physical disk.

The default name for a VM disk is `disk##` (such as `disk01`) and the default name for a subdisk is `disk##-##`. In the figure, "[Subdisk Example](#)", `disk01-01` is the name of the first subdisk on the VM disk named `disk01`.

Subdisk Example

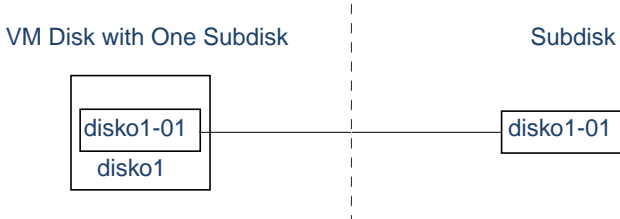

A VM disk can contain multiple subdisks, but subdisks cannot overlap or share the same portions of a VM disk. “[Example of Three Subdisks Assigned to One VM Disk](#)” shows a VM disk with three subdisks. The VM disk is assigned to one physical disk.

Example of Three Subdisks Assigned to One VM Disk

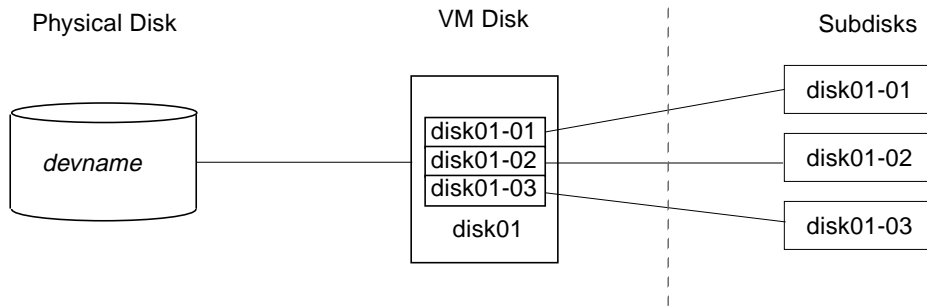

Any VM disk space that is not part of a subdisk is free space. You can use free space to create new subdisks.

VxVM release 3.0 or higher supports the concept of layered volumes in which subdisks can contain volumes. For more information, see “[Layered Volumes](#)” on page 27.

## Plexes

VxVM uses subdisks to build virtual objects called *plexes*. A plex consists of one or more subdisks located on one or more physical disks. For example, see the plex `vol01-01` shown in “[Example of a Plex with Two Subdisks](#)”

Example of a Plex with Two Subdisks

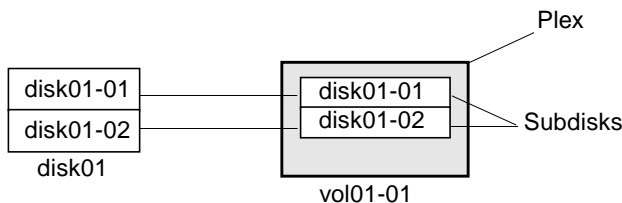

You can organize data on subdisks to form a plex by using the following methods:

- ◆ Concatenation
- ◆ Striping (RAID-0)
- ◆ Mirroring (RAID-1)
- ◆ Striping with parity (RAID-5)

Concatenation, striping (RAID-0), mirroring (RAID-1) and RAID-5 are described in “[Volume Layouts in VxVM](#)” on page 11.

### Volumes

A *volume* is a virtual disk device that appears to applications, databases, and file systems like a physical disk device, but does not have the physical limitations of a physical disk device. A volume consists of one or more plexes, each holding a copy of the selected data in the volume. Due to its virtual nature, a volume is not restricted to a particular disk or a specific area of a disk. The configuration of a volume can be changed by using VxVM user interfaces. Configuration changes can be accomplished without causing disruption to applications or file systems that are using the volume. For example, a volume can be mirrored on separate disks or moved to use different disk storage.

**Note** VxVM uses the default naming conventions of `vol##` for volumes and `vol##-##` for plexes in a volume. For ease of administration, you can choose to select more meaningful names for the volumes that you create.

A volume may be created under the following constraints:

- ◆ It can consist of up to 32 plexes, each of which contains one or more subdisks.
- ◆ It must have at least one associated plex that has a complete copy of the data in the volume with at least one associated subdisk.
- ◆ All subdisks within a volume must belong to the same disk group.

See “[Example of a Volume with One Plex](#)”.

Example of a Volume with One Plex

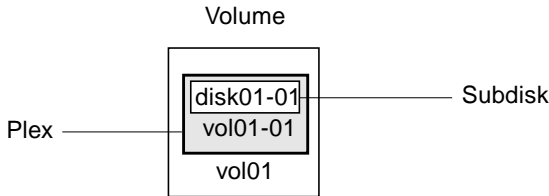

Volume `vol01` has the following characteristics:

- ◆ It contains one plex named `vol01-01`.
- ◆ The plex contains one subdisk named `disk01-01`.
- ◆ The subdisk `disk01-01` is allocated from VM disk `disk01`.



A volume with two or more data plexes is “mirrored” and contains mirror images of the data. See “[Example of a Volume with Two Plexes](#)”

Example of a Volume with Two Plexes

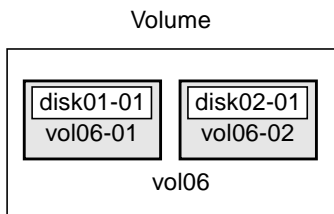

Each plex contains an identical copy of the volume data. For more information, see “[Mirroring \(RAID-1\) in VxVM](#)” on page 18.

Volume `vol06` in Figure has the following characteristics:

- ◆ It contains two plexes named `vol06-01` and `vol06-02`
- ◆ Each plex contains one subdisk
- ◆ Each subdisk is allocated from a different VM disk (`disk01` and `disk02`)

## Combining Virtual Objects in VxVM

VxVM virtual objects are combined to build volumes. The virtual objects contained in volumes are VM disks, disk groups, subdisks, and plexes. VERITAS Volume Manager objects are organized as follows:

- ◆ Disks are grouped into disk groups
- ◆ Subdisks (each representing a specific region of a disk) are combined to form plexes
- ◆ Volumes are composed of one or more plexes

The figure, “[Connection Between Objects in VxVM](#)”, shows the connections between VERITAS Volume Manager virtual objects and how they relate to physical disks. Figure shows a disk group with two VM disks (`disk01` and `disk02`). `disk01` has a volume with one plex and two subdisks. `disk02` has a volume with one plex and a single subdisk

## Connection Between Objects in VxVM

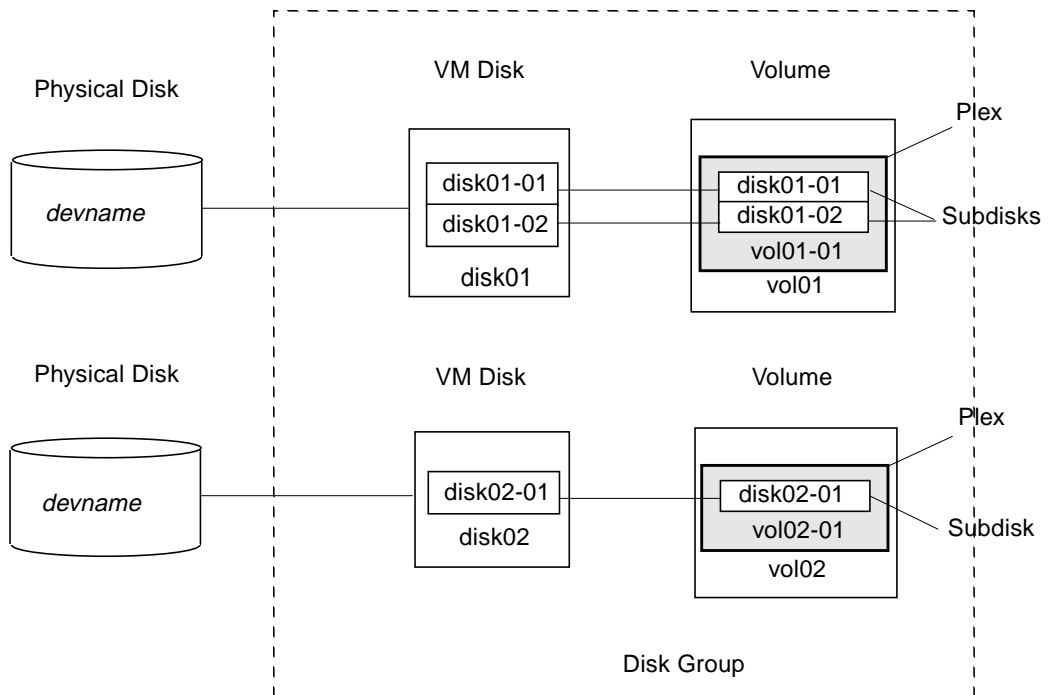

## Volume Layouts in VxVM

A VxVM virtual device is defined by a volume. A volume has a layout defined by the association of a volume to one or more plexes, each of which map to subdisks. The volume then presents a virtual device interface exposed to VERITAS Volume Manager clients for data access. These logical building blocks re-map the volume address space through which I/O is re-directed at run-time.

Different volume layouts each provide different levels of storage service. A volume layout can be configured and reconfigured to match particular levels of desired storage service.

In previous releases of VxVM, the subdisk was restricted to mapping directly to a VM disk. This allowed the subdisk to define a contiguous extent of storage space backed by the public region of a VM disk. When active, the VM disk is associated with an underlying physical disk. This is how VxVM logical objects map to physical objects, and store data on stable storage.

The combination of a volume layout and the physical disks therefore determine the storage service available from a given virtual device.



## Implementation of Layered Volumes

In VxVM 3.0 and later releases, a *layered volume* can be constructed by mapping its subdisks to underlying volumes. The subdisks in the underlying volumes must map to VM disks, and hence to attached physical storage.

Layered volumes allow for more combinations of logical compositions, some of which may be desirable for configuring a virtual device. Because permitting free use of layered volumes throughout the command level would have resulted in unwieldy administration, some ready-made layered volume configurations were designed into VxVM.

These ready-made configurations operate with built-in rules to automatically match desired levels of service within specified constraints. The automatic configuration is done on a “best-effort” basis for the current command invocation working against the current configuration.

To achieve the desired storage service from a set of virtual devices, it may be necessary to include an appropriate set of VM disks into a disk group, and to execute multiple configuration commands.

To the extent that it can, VxVM handles initial configuration and on-line re-configuration with its set of layouts and administration interface to make this job easier and more deterministic.

## Layout Methods

Data in virtual objects is organized to create volumes by using the following layout methods:

- ◆ Concatenation and spanning
- ◆ Striping (RAID-0)
- ◆ Mirroring (RAID-1)
- ◆ Striping plus mirroring (RAID-0+1)
- ◆ Mirroring plus striping (RAID-1+0 or RAID-10)
- ◆ RAID-5 (striping with parity)

The following sections describe each layout method.

## Concatenation and Spanning

*Concatenation* maps data in a linear manner onto one or more subdisks in a plex. To access all of the data in a concatenated plex sequentially, data is first accessed in the first subdisk from beginning to end. Data is then accessed in the remaining subdisks sequentially from beginning to end, until the end of the last subdisk.

The subdisks in a concatenated plex do not have to be physically contiguous and can belong to more than one VM disk. Concatenation using subdisks that reside on more than one VM disk is called *spanning*.

The figure, “[Example of Concatenation](#)”, shows concatenation with one subdisk.

Example of Concatenation

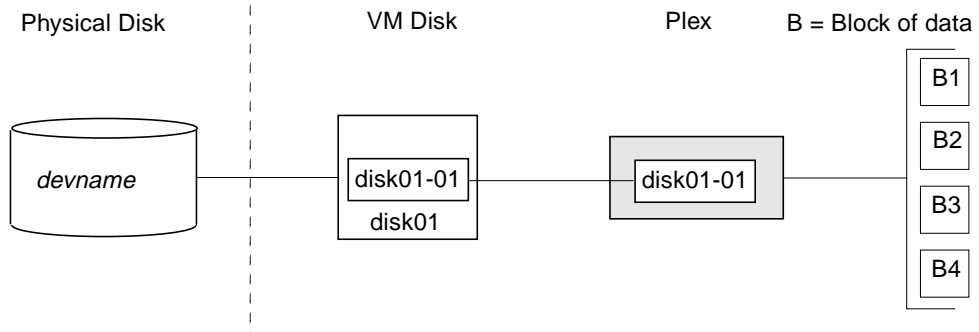

You can use concatenation with multiple subdisks when there is insufficient contiguous space for the plex on any one disk. This form of concatenation can be used for load balancing between disks, and for head movement optimization on a particular disk. See the figure, “[Example of a Volume in a Concatenated Configuration](#).”

Example of a Volume in a Concatenated Configuration

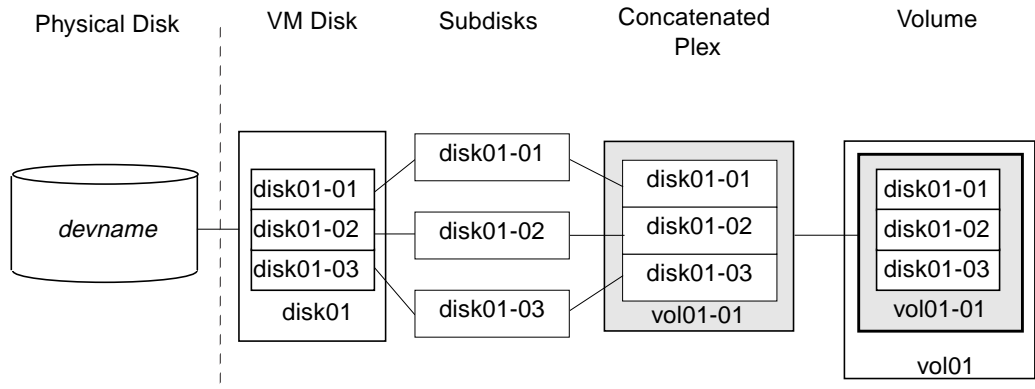

The figure, “[Example of Spanning](#)” on page 14 shows data spread over two subdisks in a spanned plex. In the figure, “[Example of Spanning](#),” the first six blocks of data (B1 through B6) use most of the space on the disk to which VM disk `disk01` is assigned. This requires space only on subdisk `disk01-01` on `disk01`. However, the last two blocks of data, B7 and B8, use only a portion of the space on the disk to which VM disk `disk02` is assigned.

The remaining free space on VM disk `disk02` can be put to other uses. In this example, subdisks `disk02-02` and `disk02-03` are available for other disk management tasks.

#### Example of Spanning

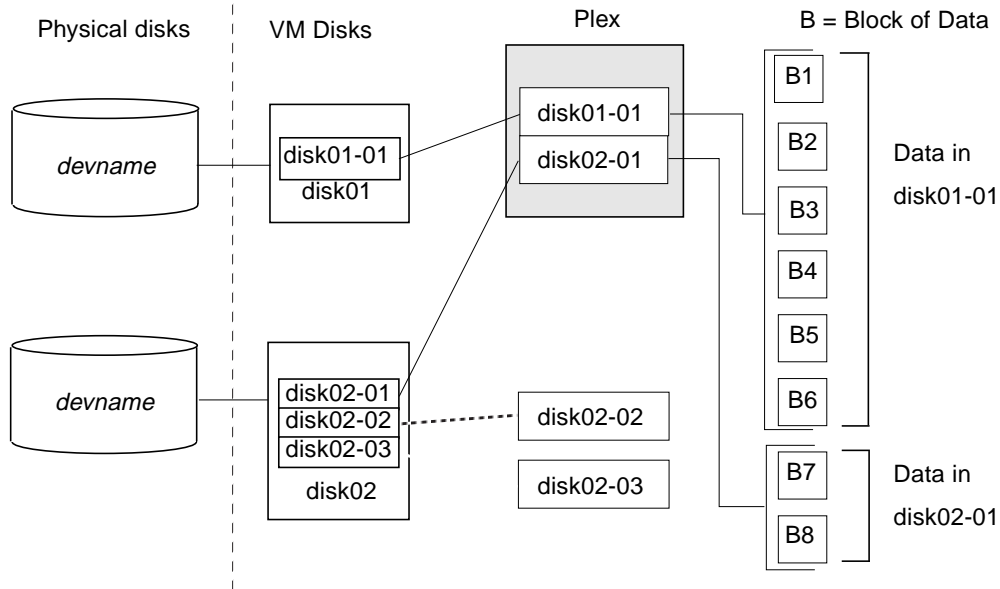

**Caution** Spanning a plex across multiple disks increases the chance that a disk failure results in failure of the assigned volume. Use mirroring or RAID-5 (both described later) to reduce the risk that a single disk failure results in a volume failure.

See “[Creating a Volume on Any Disk](#)” on page 127 for information on how to create a concatenated volume that may span several disks.



## Striping (RAID-0) in VxVM

Striping (RAID-0) is useful if you need large amounts of data written to or read from physical disks, and performance is important. Striping is also helpful in balancing the I/O load from multi-user applications across multiple disks. By using parallel data transfer to and from multiple disks, striping significantly improves data-access performance.

Striping maps data so that the data is interleaved among two or more physical disks. A striped plex contains two or more subdisks, spread out over two or more physical disks. Data is allocated alternately and evenly to the subdisks of a striped plex.

The subdisks are grouped into “columns,” with each physical disk limited to one column. Each column contains one or more subdisks and can be derived from one or more physical disks. The number and sizes of subdisks per column can vary. Additional subdisks can be added to columns, as necessary.

---

**Caution** Striping a volume, or splitting a volume across multiple disks, increases the chance that a disk failure will result in failure of that volume.

---

If five volumes are striped across the same five disks, then failure of any one of the five disks will require that all five volumes be restored from a backup. If each volume is on a separate disk, only one volume has to be restored. Use mirroring or RAID-5 to substantially reduce the chance that a single disk failure results in failure of a large number of volumes.

Data is allocated in equal-sized units (*stripe units*) that are interleaved between the columns. Each stripe unit is a set of contiguous blocks on a disk. The default stripe unit size (or *width*) is 64 kilobytes.

For example, if there are three columns in a striped plex and six stripe units, data is striped over three physical disks, as shown in the figure, “[Striping Across Three Disks \(Columns\)](#)”:

- ◆ The first and fourth stripe units are allocated in column 1
- ◆ The second and fifth stripe units are allocated in column 2
- ◆ The third and sixth stripe units are allocated in column 3



## Striping Across Three Disks (Columns)

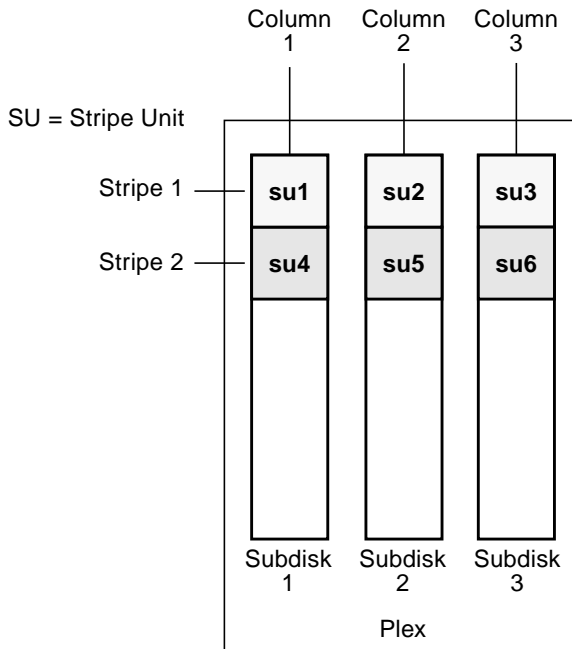

A *stripe* consists of the set of stripe units at the same positions across all columns. In the figure “[Striping Across Three Disks \(Columns\)](#),” stripe units 1, 2, and 3 constitute a single stripe.

Viewed in sequence, the first stripe consists of:

- ◆ stripe unit 1 in column 1
- ◆ stripe unit 2 in column 2
- ◆ stripe unit 3 in column 3

The second stripe consists of:

- ◆ stripe unit 4 in column 1
- ◆ stripe unit 5 in column 2
- ◆ stripe unit 6 in column 3

Striping continues for the length of the columns (if all columns are the same length) or until the end of the shortest column is reached. Any space remaining at the end of subdisks in longer columns becomes unused space.

The figure, “[Example of a Striped Plex with One Subdisk per Column](#)”, shows a striped plex with three equal sized, single-subdisk columns. There is one column per physical disk.

Example of a Striped Plex with One Subdisk per Column

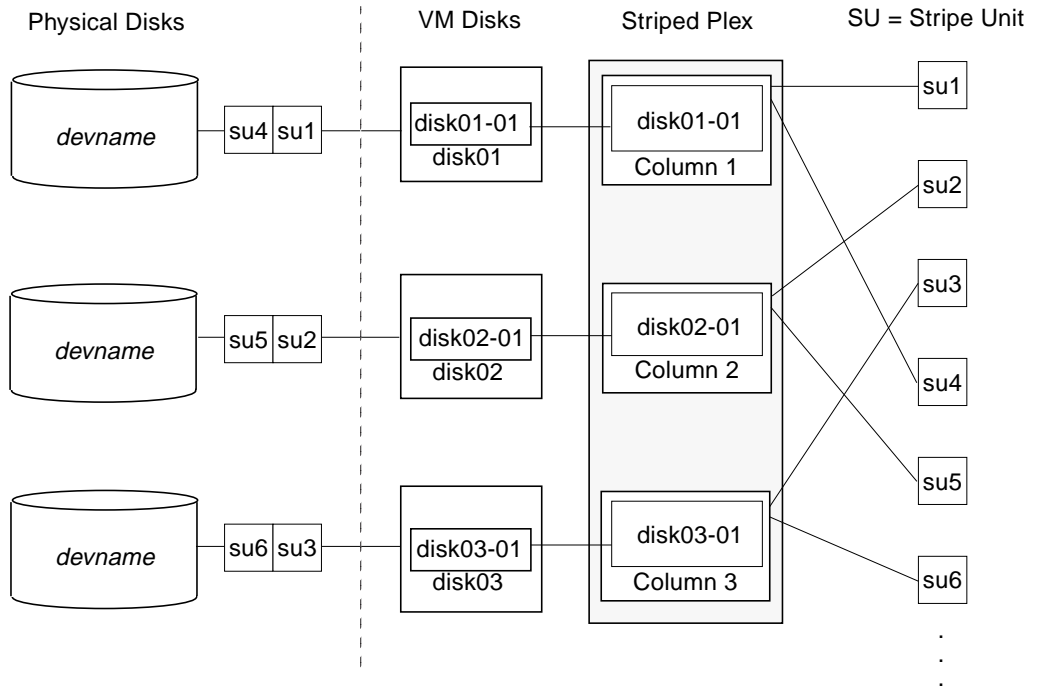

This example shows three subdisks that occupy all of the space on the VM disks. It is also possible for each subdisk in a striped plex to occupy only a portion of the VM disk, which leaves free space for other disk management tasks.

The figure, “[Example of a Striped Plex with Concatenated Subdisks per Column](#)”, illustrates a striped plex with three columns containing subdisks of different sizes. Each column contains a different number of subdisks. There is one column per physical disk. Striped plexes can be created by using a single subdisk from each of the VM disks being striped across. It is also possible to allocate space from different regions of the same disk or from another disk (for example, if the size of the plex is increased). Columns can also contain subdisks from different VM disks.



Example of a Striped Plex with Concatenated Subdisks per Column

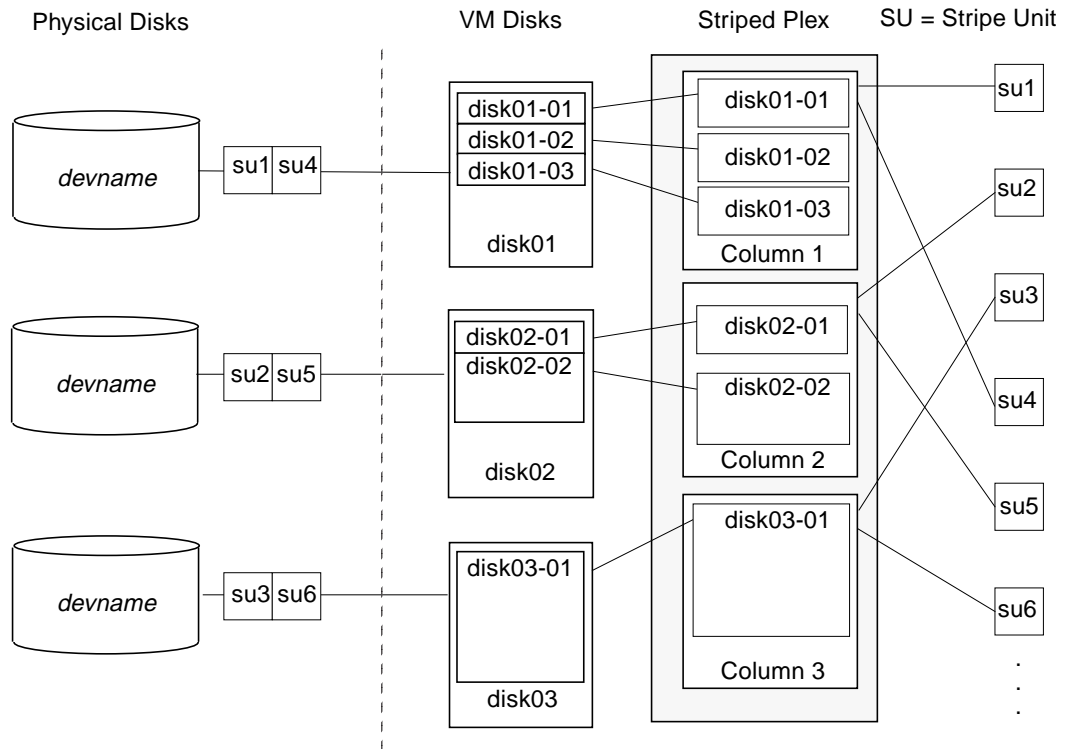

See “[Creating a Striped Volume](#)” on page 130 for information on how to create a striped volume.

## Mirroring (RAID-1) in VxVM

*Mirroring* uses multiple mirrors (plexes) to duplicate the information contained in a volume. In the event of a physical disk failure, the plex on the failed disk becomes unavailable, but the system continues to operate using the unaffected mirrors.

**Note** Although a volume can have a single plex, at least two plexes are required to provide redundancy of data. Each of these plexes must contain disk space from *different* disks to achieve redundancy.

When striping or spanning across a large number of disks, failure of any one of those disks can make the entire plex unusable. Because the likelihood of one out of several disks failing is reasonably high, you should consider mirroring to improve the reliability (and availability) of a striped or spanned volume.

See “[Creating a Mirrored Volume](#)” on page 129 for information on how to create a mirrored volume.

## Striping Plus Mirroring (Mirrored-Stripe or RAID-0+1)

VxVM supports the combination of mirroring above striping. The combined layout is called a *mirrored-stripe* layout. A mirrored-stripe layout offers the dual benefits of striping to spread data across multiple disks, while mirroring provides redundancy of data.

For mirroring above striping to be effective, the striped plex and its mirrors must be allocated from *separate* disks.

The figure below, “[Mirrored-Stripe Volume Laid out on Six Disks](#),” shows an example where two plexes, each striped across three disks, are attached as mirrors to the same volume to create a mirrored-stripe volume.

Mirrored-Stripe Volume Laid out on Six Disks

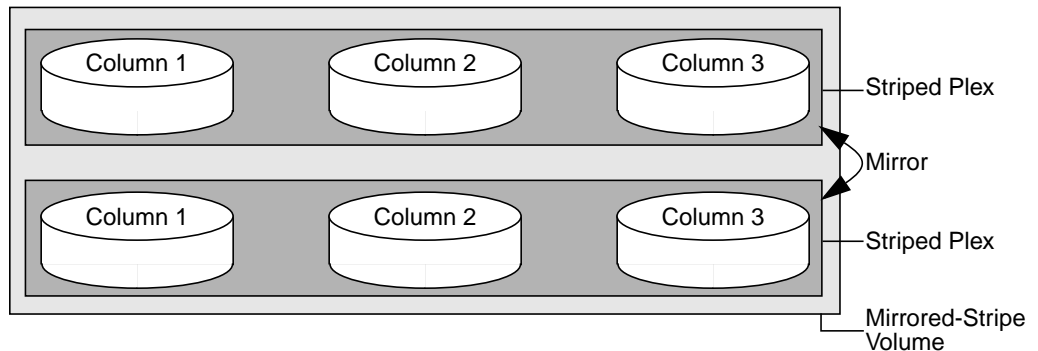

See “[Creating a Mirrored-Stripe Volume](#)” on page 131 for information on how to create a mirrored-stripe volume.

The layout type of the data plexes in a mirror can be concatenated or striped. Even if only one is striped, the volume is still termed a mirrored-stripe volume. If they are all concatenated, the volume is termed a *mirrored-concatenated* volume.



## Mirroring Plus Striping (Striped-Mirror, RAID-1+0 or RAID-10)

**Note** VxVM supports this feature for private disk groups, but not for shareable disk groups in a cluster environment.

VxVM supports the combination of striping above mirroring. This combined layout is called a *striped-mirror* layout. Putting mirroring below striping mirrors each column of the stripe. If there are multiple subdisks per column, each subdisk can be mirrored individually instead of each column.

**Note** A striped-mirror volume is an example of a layered volume. See “[Layered Volumes](#)” on page 27 for more information.

As for a mirrored-stripe volume, a striped-mirror volume offers the dual benefits of striping to spread data across multiple disks, while mirroring provides redundancy of data. In addition, it enhances redundancy, and reduces recovery time after disk failure.

The figure below, “[Striped-Mirror Volume Laid out on Six Disks](#),” shows an example where a striped-mirror volume is created by using each of three existing 2-disk mirrored volumes to form a separate column within a striped plex.

Striped-Mirror Volume Laid out on Six Disks

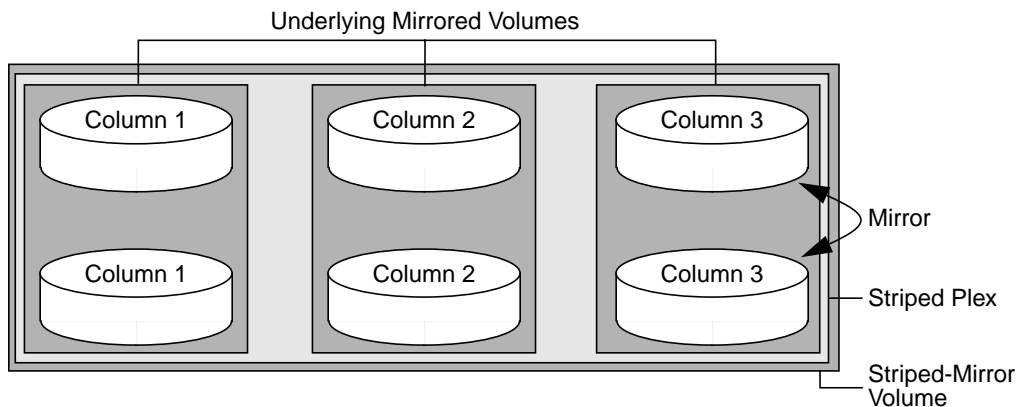

See “[Creating a Striped-Mirror Volume](#)” on page 131 for information on how to create a striped-mirrored volume.

As shown in the figure, “[How the Failure of a Single Disk Affects Mirrored-Stripe and Striped-Mirror Volumes](#),” the failure of a disk in a mirrored-stripe layout detaches an entire data plex, thereby losing redundancy on the entire volume. When the disk is replaced, the entire plex must be brought up to date. Recovering the entire plex can take a substantial amount of time. If a disk fails in a striped-mirror layout, only the failing subdisk must be detached, and only that portion of the volume loses redundancy. When

the disk is replaced, only a portion of the volume needs to be recovered. Additionally, a mirrored-stripe volume is more vulnerable to being put out of use altogether should a second disk fail before the first failed disk has been replaced, either manually or by hot-relocation.

How the Failure of a Single Disk Affects Mirrored-Stripe and Striped-Mirror Volumes

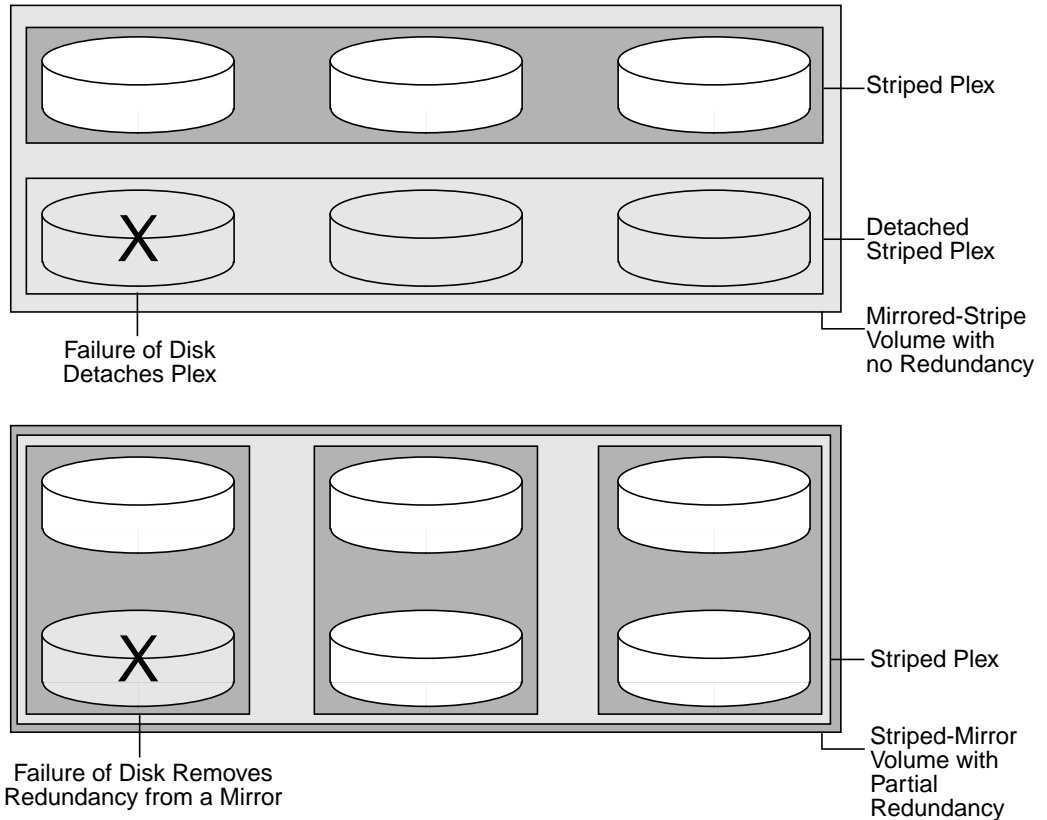

Compared to mirrored-stripe volumes, striped-mirror volumes are more tolerant of disk failure, and recovery time is shorter.

If the layered volume concatenates instead of striping the underlying mirrored volumes, the volume is termed a *concatenated-mirror* volume.

**Note** The VERITAS Volume Manager Storage Administrator (VMSA) terms a striped-mirror as *Striped-Pro*, and a concatenated-mirror as *Concatenated-Pro*.



## RAID-5 in VxVM

**Note** VxVM supports this feature for private disk groups, but not for shareable disk groups in a cluster environment.

Although both mirroring (RAID-1) and RAID-5 provide redundancy of data, they use different methods. Mirroring provides data redundancy by maintaining multiple complete copies of the data in a volume. Data being written to a mirrored volume is reflected in all copies. If a portion of a mirrored volume fails, the system continues to use the other copies of the data.

RAID-5 provides data redundancy by using *parity*. Parity is a calculated value used to reconstruct data after a failure. While data is being written to a RAID-5 volume, parity is calculated by doing an exclusive OR (XOR) procedure on the data. The resulting parity is then written to the volume. The data and calculated parity are contained in a plex that is “striped” across multiple disks. If a portion of a RAID-5 volume fails, the data that was on that portion of the failed volume can be recreated from the remaining data and parity information. It is also possible to mix concatenation and striping in the layout.

The figure, “[Parity Locations in a RAID-5 Model](#)”, shows parity locations in a RAID-5 array configuration. Every stripe has a column containing a parity stripe unit and columns containing data. The parity is spread over all of the disks in the array, reducing the write time for large independent writes because the writes do not have to wait until a single parity disk can accept the data.

Parity Locations in a RAID-5 Model

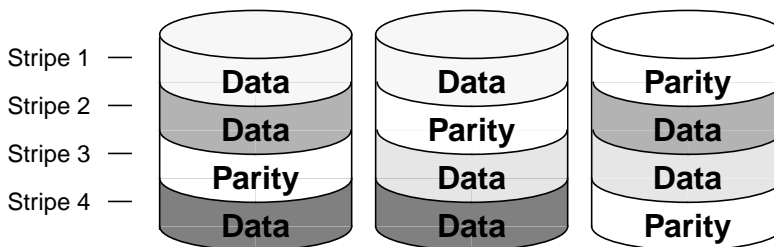

RAID-5 and how it is implemented by the VxVM is described in “[VERITAS Volume Manager RAID-5 Arrays](#)” on page 23.

RAID-5 volumes can additionally perform logging to minimize recovery time. RAID-5 volumes use RAID-5 logs to keep a copy of the data and parity currently being written. RAID-5 logging is optional and can be created along with RAID-5 volumes or added later.



## Traditional RAID-5 Arrays

A *traditional* RAID-5 array is several disks organized in rows and columns. A *column* is a number of disks located in the same ordinal position in the array. A *row* is the minimal number of disks necessary to support the full width of a parity stripe. The figure, “[Traditional RAID-5 Array](#)”, shows the row and column arrangement of a traditional RAID-5 array.

Traditional RAID-5 Array

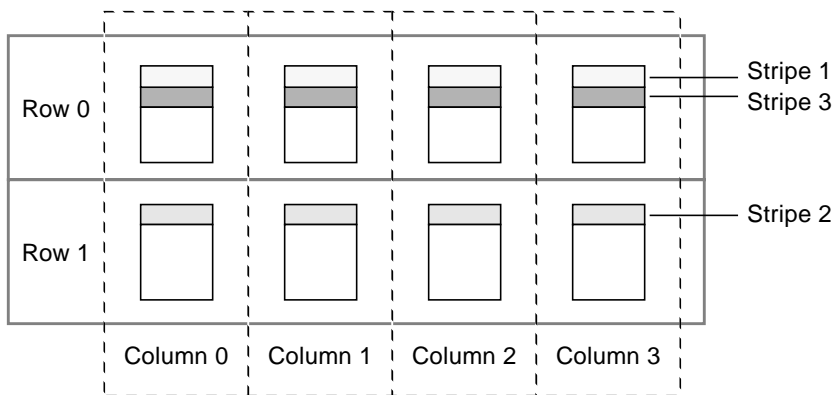

This traditional array structure supports growth by adding more rows per column. Striping is accomplished by applying the first stripe across the disks in Row 0, then the second stripe across the disks in Row 1, then the third stripe across the Row 0 disks, and so on. This type of array requires all disks columns, and rows to be of equal size.

## VERITAS Volume Manager RAID-5 Arrays

VERITAS Volume Manager RAID-5 array structure differs from the traditional structure. Due to the virtual nature of its disks and other objects, VxVM does not use rows. Instead, VxVM uses columns consisting of variable length subdisks (as shown in “[VERITAS Volume Manager RAID-5 Array](#)” on page 24). Each subdisk represents a specific area of a disk.



## VERITAS Volume Manager RAID-5 Array

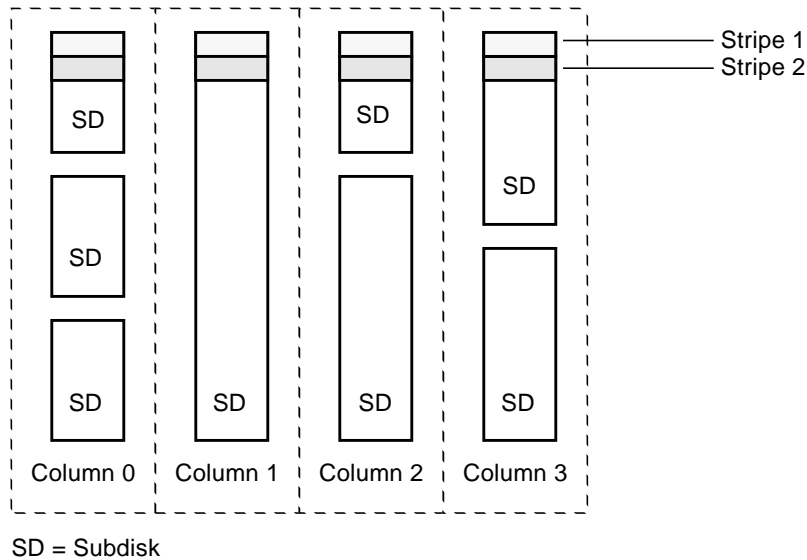

With the VxVM RAID-5 array structure, each column can consist of a different number of subdisks. The subdisks in a given column can be derived from different physical disks. Additional subdisks can be added to the columns as necessary. Striping is done by applying the first stripe across each subdisk at the top of each column, then another stripe below that, and so on for the length of the columns. For each stripe, an equal-sized stripe unit is placed in each column. With RAID-5, the default stripe unit size is 16 kilobytes. See “[Striping \(RAID-0\) in VxVM](#)” on page 15 for further information

---

**Note** Mirroring of RAID-5 volumes is not currently supported.

---

### Left-Symmetric Layout

There are several layouts for data and parity that can be used in the setup of a RAID-5 array. The implementation of RAID-5 in VxVM is the left-symmetric layout. The left-symmetric parity layout provides optimal performance for both random I/O operations and large sequential I/O operations. In terms of performance, the layout selection is not as critical as the number of columns and the stripe unit size.

The left-symmetric layout stripes both data and parity across columns, placing the parity in a different column for every stripe of data. The first parity stripe unit is located in the rightmost column of the first stripe. Each successive parity stripe unit is located in the next stripe, shifted left one column from the previous parity stripe unit location. If there are more stripes than columns, the parity stripe unit placement begins in the rightmost column again.

The figure, “[Left-Symmetric Layout](#)”, shows a left-symmetric parity layout with five disks (one per column).

Left-Symmetric Layout

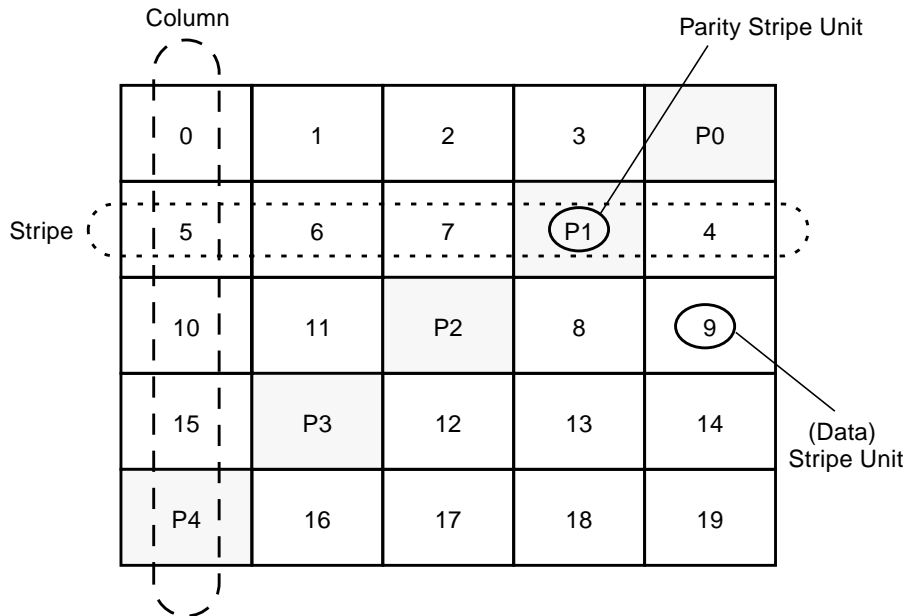

For each stripe, data is organized starting to the right of the parity stripe unit. In Figure , data organization for the first stripe begins at P0 and continues to stripe units 0-3. Data organization for the second stripe begins at P1, then continues to stripe unit 4, and on to stripe units 5-7. Data organization proceeds in this manner for the remaining stripes.

Each parity stripe unit contains the result of an exclusive OR (XOR) procedure done on the data in the data stripe units within the same stripe. If data on a disk corresponding to one column is inaccessible due to hardware or software failure, data can be restored. Data is restored by XORing the contents of the remaining columns data stripe units against their respective parity stripe units (for each stripe).

For example, if the disk corresponding to the far left column in Figure fails, the volume is placed in a degraded mode. While in degraded mode, the data from the failed column can be recreated by XORing stripe units 1-3 against parity stripe unit P0 to recreate stripe unit 0, then XORing stripe units 4, 6, and 7 against parity stripe unit P1 to recreate stripe unit 5, and so on.



**Note** Failure of multiple columns in a plex with a RAID-5 layout detaches the volume. The volume is no longer allowed to satisfy read or write requests. Once the failed columns have been recovered, it may be necessary to recover the user data from backups.

See “[Creating a RAID-5 Volume](#)” on page 132 for information on how to create a RAID-5 volume.

## RAID-5 Logging

*Logging* is used to prevent corruption of data during recovery by immediately recording changes to data and parity to a log area on a *persistent* device (such as a disk-resident volume or non-volatile RAM). The new data and parity are then written to the disks.

Without logging, it is possible for data not involved in any active writes to be lost or silently corrupted if both a disk in a RAID-5 volume and the system fail. If this double-failure occurs, there is no way of knowing if the data being written to the data portions of the disks or the parity being written to the parity portions have actually been written. Therefore, the recovery of the corrupted disk may be corrupted itself.

In the figure, “[Incomplete Write](#)”, the recovery of Disk B depends on the data on Disk A and the parity on Disk C both being complete. The diagram shows a completed data write and an incomplete parity write. This would cause the data on Disk B to be reconstructed incorrectly.

Incomplete Write

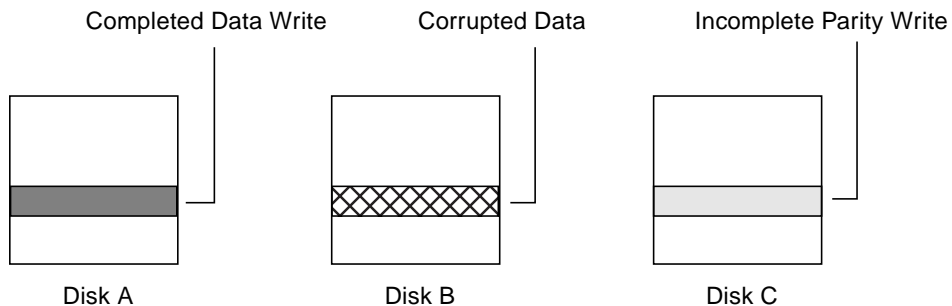

This failure can be avoided by logging all data and parity writes before committing them to the array. In this way, the log can be replayed, causing the data and parity updates to be completed before the reconstruction of the failed drive takes place.

Logs are associated with a RAID-5 volume by being attached as log plexes. More than one log plex can exist for each RAID-5 volume, in which case the log areas are mirrored.

See “[Adding a RAID-5 Log](#)” on page 148 for information on how to add a RAID-5 log to a RAID-5 volume.

## Layered Volumes

**Note** VxVM supports this feature for private disk groups, but not for shareable disk groups in a cluster environment.

A *layered volume* is a virtual VERITAS Volume Manager object that is built on top of other volumes. The layered volume structure tolerates failure better and has greater redundancy than the standard volume structure. For example, in a striped-mirror layered volume, each mirror (plex) covers a smaller area of storage space, so recovery is quicker than with a standard mirrored volume.

The figure, “[Example of a Striped-Mirror Layered Volume](#)”, shows an example of a layered volume. It illustrates how the volume and striped plex in the “Managed by User” area allow you to perform normal tasks in VxVM. User tasks can be performed only on the top-level volume of a layered volume. You cannot detach a layered volume or perform any other operation on the underlying volumes by manipulating the internal structure. You can perform all necessary operations from the user manipulation area that includes the volume and striped plex (for example, changing the column width, or adding a column).

“[Example of a Striped-Mirror Layered Volume](#)” shows subdisks with two columns, built on underlying volumes with each volume internally mirrored. Layered volumes are an infrastructure within VxVM that allow the addition of certain features to be added to VxVM. Underlying volumes are used exclusively by VxVM and are not designed for user manipulation. The underlying volume structure is described here to help you understand how layered volumes work and why they are used by VxVM.

Example of a Striped-Mirror Layered Volume

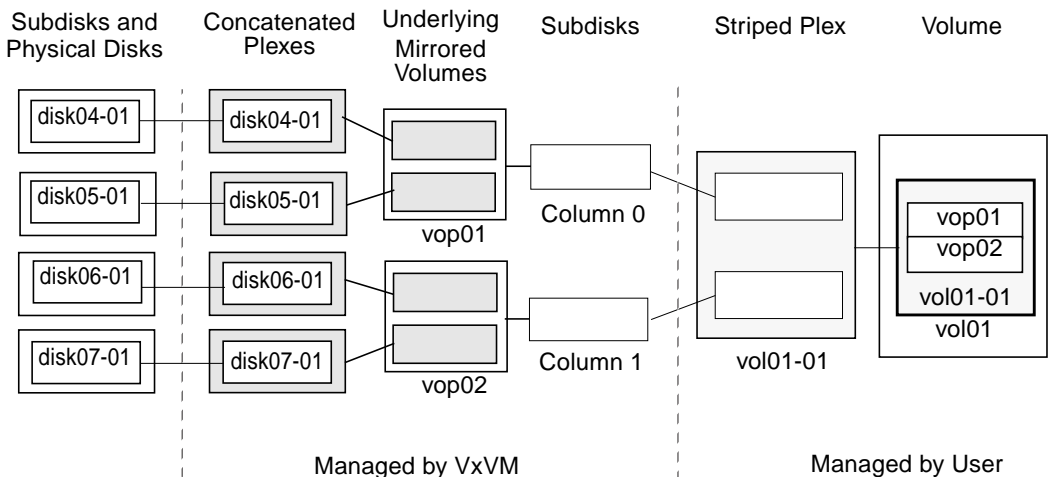

**Note** VxVM 3.0 and later releases support layered volumes, and also allow the creation of storage volumes from subdisks built on top of volumes. Earlier releases do not support this functionality.

---

System administrators can manipulate the layered volume structure for troubleshooting or other operations (for example, to place data on specific disks). Layered volumes are used by VxVM to perform the following tasks and operations:

- ◆ Striped-mirrors. (See the `vxassist(1M)` manual page.)
- ◆ Concatenated-mirrors. (See the `vxassist(1M)` manual page.)
- ◆ Online Relayout. (See “[Online Relayout](#)” on page 28 and the `vxrelayout(1M)` and `vxassist(1M)` manual pages.)
- ◆ RAID-5 subdisk moves. (See the `vxsd(1M)` manual page.)
- ◆ Snapshots. (See “[Backing Up Volumes Online Using Snapshots](#)” on page 159, and the `vxassist(1M)` manual page.)

**Note** The VMSA terms a striped-mirror as `Striped-Pro`, and a concatenated-mirror as `Concatenated-Pro`.

---

See “[Creating a Striped-Mirror Volume](#)” on page 131 for information on how to create a striped-mirrored volume.

See “[Creating a Concatenated-Mirror Volume](#)” on page 129 for information on how to create a concatenated-mirrored volume.

## Online Relayout

**Note** VxVM supports this feature for private disk groups, but not for shareable disk groups in a cluster environment.

---

*Online relayout* allows you to convert any supported storage layout in VxVM to any other, in place, with *uninterrupted data access*. You usually change the storage layout in VxVM to change the redundancy or performance characteristics of the storage. VxVM adds redundancy to storage either by duplicating the address space (mirroring) or by adding parity (RAID-5). Performance characteristics of storage in VxVM can be changed by changing the striping parameters, which are the number of columns and the stripe width.

See “[Performing Online Relayout](#)” on page 163 for details of how to perform online relayout of volumes in VxVM. Also see “[Converting Between Layered and Non-Layered Volumes](#)” on page 166 for information about additional volume conversion operations that are possible.

## How Online Relayout Works

Online relayout allows you to change storage layouts that you have already created in place, without disturbing data access. You can change the performance characteristics of a particular layout to suit changed requirements. You can transform one layout to another by invoking a single command.

---

**Note** Changing the number of mirrors during a transformation is not currently supported.

---

For example, if a striped layout with a 128K stripe unit size is not providing optimal performance, you can use relayout to change the stripe unit size.

File systems mounted on the volumes do not need to be unmounted to achieve this transformation provided that the file system (such as VxFS) supports online shrink and grow operations.

Online relayout reuses the existing storage space and has space allocation policies to address the needs of the new layout. The layout transformation process converts a given volume to the destination layout by using minimal temporary space that is available in the disk group.

The transformation is done by moving one portion of data at a time in the source layout to the destination layout. Data is copied from the source volume to the temporary area, and data is removed from the source volume storage area in portions. The source volume storage area is then transformed to the new layout and data saved in the temporary area is written back to the new layout. This operation is repeated until all the storage and data in the source volume has been transformed to the new layout.

The default size of the temporary area used during the relayout depends on the size of the source volume:

- ◆ If the source volume is smaller than 50 MB, the temporary space used is the same size as the volume.
- ◆ If the source volume is larger than 50 MB but smaller than 1 gigabyte, the temporary space used is 50 MB.
- ◆ If the source volume is larger than 1 GB, the temporary space used is 1 GB.

---

**Note** There must be sufficient free space in the disk group available for the temporary area.

---

You can override the default size used for the temporary area by using the `tmpsize` attribute to `vxassist`. See the `vxassist(1M)` manual page for more information.



## Permitted Transformations

You can perform one or more of the following operations:

- ◆ Change RAID-5 to a layered mirror
- ◆ Change a mirror to RAID-5
- ◆ Change the number of columns
- ◆ Change the stripe width
- ◆ Remove or add parity

For details of how to perform online relayout operations, see “[Performing Online Relayout](#)” on page 163

However, you should also note the following limitations:

- ◆ To be eligible for layout transformation, mirrored volume plexes must be identical in layout, with the same stripe width and number of columns.
- ◆ A relayout cannot create a non-layered mirrored volume in a single step. Use the `vxassist convert` command to turn the layered mirrored volume resulting from a relayout into a non-layered volume. See “[Converting Between Layered and Non-Layered Volumes](#)” on page 166 for more information.
- ◆ When performing relayout on a non-layered mirrored volume to a concatenated, concatenated-mirror, striped or striped-mirrored volume, the destination volume remains mirrored even if the layout attribute is specified as `striped` or `nomirror`. The unwanted mirror plexes must be removed after the relayout has finished. If the destination volume is RAID-5, the remaining plexes are removed at the end of the relayout operation.
- ◆ Online relayout can be used only with volumes created with the `vxassist` command or the VMSA.
- ◆ Sparse plexes are not transformed by online relayout, and no plex can be rendered sparse by online relayout. A sparse plex is a plex that is not as long as the volume or that has holes (regions of the plex that do not have a backing subdisk).

See the following tables for details of the relayout operations that are possible for each type of source storage layout.



## Supported Relayout Transformations for Concatenated Volumes

To	From Concatenated
<b>Concatenated</b>	No.
<b>Concatenated-Mirror</b>	No. This requires the addition of a mirror.
<b>RAID-5</b>	Yes. The stripe width and number of columns may be defined.
<b>Non-Layered Mirror</b>	No, although it is possible to convert to a mirrored stripe volume from a striped mirrored volume, or to a mirrored concatenated volume from a concatenated mirrored volume.
<b>Striped</b>	Yes. The stripe width and number of columns may be defined.
<b>Striped-Mirror</b>	Yes. The stripe width and number of columns may be defined.

## Supported Relayout Transformations for Concatenated Mirrored Volumes

To	From Concatenated Mirror
<b>Concatenated</b>	No. This requires the removal of a mirror.
<b>Concatenated-Mirror</b>	No.
<b>RAID-5</b>	Yes. The stripe width and number of columns may be defined. Choose a plex in the existing mirrored volume on which to perform the relayout. The other plexes are removed at the end of the relayout operation.
<b>Non-Layered Mirror</b>	No, although it is possible to convert to a mirrored stripe volume from a striped-mirrored volume, or to a mirrored-concatenated volume from a concatenated-mirrored volume.
<b>Striped</b>	Yes. This removes a mirror and adds striping. The stripe width and number of columns may be defined. Choose a plex in the existing mirrored volume on which to perform the relayout.
<b>Striped-Mirror</b>	Yes. The stripe width and number of columns may be defined. Choose a plex in the existing mirrored volume on which to perform the relayout.



Supported Relayout Transformations for RAID-5 Volumes

To	From RAID-5
<b>Concatenated</b>	Yes.
<b>Concatenated-Mirror</b>	Yes.
<b>RAID-5</b>	Yes. The stripe width and number of columns may be changed.
<b>Non-Layered Mirror</b>	No, although it is possible to convert to a mirrored-stripe volume from a striped-mirrored volume, or to a mirrored-concatenated volume from a concatenated-mirrored volume.
<b>Striped</b>	Yes. The stripe width and number of columns may also be changed.
<b>Striped-Mirror</b>	Yes. The stripe width and number of columns may also be changed.

Supported Relayout Transformations for Regular Mirrored Volumes

To	From Non-Layered Mirror
<b>Concatenated</b>	No.
<b>Concatenated-Mirror</b>	Yes if the number of columns or stripe size is changed for a striped plex in the existing mirrored volume. Otherwise, this is a convert rather than a relayout operation.
<b>RAID-5</b>	Yes. The stripe width and number of columns may be defined. Choose a plex in the existing mirrored volume on which to perform the relayout. The other plexes are removed at the end of the relayout operation.
<b>Non-Layered Mirror</b>	No.
<b>Striped</b>	Yes if you choose a striped plex in the existing mirrored stripe volume on which to perform the relayout, and also change the stripe width or number of columns.
<b>Striped-Mirror</b>	Yes if the number of columns or stripe size is changed for a striped plex in the existing mirrored-stripe volume. Otherwise, this requires a convert rather than a relayout operation.



## Supported Relayout Transformations for Striped Volumes

To	From Striped
<b>Concatenated</b>	Yes.
<b>Concatenated Mirror</b>	Yes.
<b>RAID-5</b>	Yes. The stripe width and number of columns may be changed.
<b>Non-Layered Mirror</b>	No, although it is possible to convert to a mirrored-stripe volume from a striped-mirrored volume, or to a mirrored-concatenated volume from a concatenated-mirrored volume.
<b>Striped</b>	Yes, but the stripe width or number of columns must be changed.
<b>Striped-Mirror</b>	Yes, but the stripe width or number of columns must be changed.

## Supported Layout Transformations for Striped Mirrored volumes

To	From Striped Mirror
<b>Concatenated</b>	Yes.
<b>Concatenated Mirror</b>	Yes. All stripe columns are removed.
<b>RAID-5</b>	Yes. The stripe width and number of columns may be changed.
<b>Non-Layered Mirror</b>	No, although it is possible to convert to a mirrored-stripe volume from a striped-mirrored volume, or to a mirrored-concatenated volume from a concatenated-mirrored volume.
<b>Striped</b>	Yes, but the stripe width or number of columns must be changed.
<b>Striped-Mirror</b>	Yes, but the stripe width or number of columns must be changed.

Transformations are also not supported for:

- ◆ Log plexes
- ◆ Snapshot of a volume when there is an online relayout operation running on the volume
- ◆ Changing the number of mirrors during a transformation

## Transformation Characteristics

Transformation of data from one layout to another involves rearrangement of data in the existing layout to the new layout. During the transformation, online relayout retains data redundancy by mirroring any temporary space used. Read/write access to data is not interrupted during the transformation.



Data is not corrupted if the system fails during a transformation. The transformation continues after the system is restored and read/write access is maintained.

You can reverse the layout transformation process at any time, but the data may not be returned to the exact previous storage location. Any existing transformation in the volume must be stopped before doing a reversal.

You can determine the transformation direction by using the `vxrelayout status` command.

These transformations eliminate I/O failures if there is sufficient redundancy and space to move the data.

## Transformations and Volume Length

Some layout transformations can cause the volume length to increase or decrease. If either of these conditions occurs, online relayout uses the `vxresize(1M)` command to shrink or grow a file system as described in “[Resizing a Volume](#)” on page 149.

## Volume Resynchronization

When storing data redundantly and using mirrored or RAID-5 volumes, VxVM ensures that all copies of the data match exactly. However, under certain conditions (usually due to complete system failures), some redundant data on a volume can become inconsistent or *unsynchronized*. The mirrored data is not exactly the same as the original data. Except for normal configuration changes (such as detaching and reattaching a plex), this can only occur when a system crashes while data is being written to a volume.

Data is written to the mirrors of a volume in parallel, as is the data and parity in a RAID-5 volume. If a system crash occurs before all the individual writes complete, it is possible for some writes to complete while others do not. This can result in the data becoming unsynchronized. For mirrored volumes, it can cause two reads from the same region of the volume to return different results, if different mirrors are used to satisfy the read request. In the case of RAID-5 volumes, it can lead to parity corruption and incorrect data reconstruction.

VxVM needs to ensure that all mirrors contain exactly the same data and that the data and parity in RAID-5 volumes agree. This process is called *volume resynchronization*. For volumes that are part of disk groups that are automatically imported at boot time (such as `rootdg`), the resynchronization process takes place when the system reboots.

Not all volumes require resynchronization after a system failure. Volumes that were never written or that were quiescent (that is, had no active I/O) when the system failure occurred could not have had outstanding writes and do not require resynchronization.

## Dirty Flags

VxVM records when a volume is first written to and marks it as *dirty*. When a volume is closed by all processes or stopped cleanly by the administrator, all writes have been completed and VxVM removes the dirty flag for the volume. Only volumes that are marked dirty when the system reboots require resynchronization.

## Resynchronization Process

The process of resynchronization depends on the type of volume. RAID-5 volumes that contain RAID-5 logs can “replay” those logs. If no logs are available, the volume is placed in reconstruct-recovery mode and all parity is regenerated. For mirrored volumes, resynchronization is done by placing the volume in recovery mode (also called *read-writeback recovery mode*). Resynchronization of data in the volume is done in the background. This allows the volume to be available for use while recovery is taking place.

The process of resynchronization can be expensive and can impact system performance. The recovery process reduces some of this impact by spreading the recoveries to avoid stressing a specific disk or controller.

For large volumes or for a large number of volumes, the resynchronization process can take time. These effects can be addressed by using dirty region logging (DRL) and FastResync (fast mirror resynchronization or FR) for mirrored volumes, or by ensuring that RAID-5 volumes have valid RAID-5 logs. See the following sections, “[Dirty Region Logging \(DRL\)](#)” and “[FastResync \(FR\) and Snapshots](#),” for more information.

For volumes used by database applications, the VxSmartSync™ Recovery Accelerator can be used (see “[VxSmartSync Recovery Accelerator](#)” on page 41).

## Dirty Region Logging (DRL)

Dirty region logging (DRL) is an optional property of a volume that is used to provide a speedy recovery of mirrored volumes after a system failure. DRL keeps track of the regions that have changed due to I/O writes to a mirrored volume. DRL uses this information to recover only the portions of the volume that need to be recovered.

If DRL is not used and a system failure occurs, all mirrors of the volumes must be restored to a consistent state. Restoration is done by copying the full contents of the volume between its mirrors. This process can be lengthy and I/O intensive. It may also be necessary to recover the areas of volumes that are already consistent.



## Dirty Region Logs

DRL logically divides a volume into a set of consecutive regions. It keeps track of volume regions that are being written to. A dirty region log is maintained that contains a status bit representing each region of the volume. For any write operation to the volume, the regions being written are marked dirty in the log before the data is written. If a write causes a log region to become dirty when it was previously clean, the log is synchronously written to disk before the write operation can occur. On system restart, VxVM recovers only those regions of the volume that are marked as dirty in the dirty region log.

## Log subdisks

*Log subdisks* are used to store the dirty region log of a volume that has DRL enabled. A volume with DRL has at least one log subdisk; multiple log subdisks can be used to mirror the dirty region log. Each log subdisk is associated with one plex of the volume. Only one log subdisk can exist per plex. If the plex contains only a log subdisk and no data subdisks, that plex can be referred to as a *log plex*.

The log subdisk can also be associated with a regular plex containing data subdisks. In that case, the log subdisk risks becoming unavailable if the plex must be detached due to the failure of one of its data subdisks.

If the `vxassist` command is used to create a dirty region log, it creates a log plex containing a single log subdisk by default. A dirty region log can also be set up manually by creating a log subdisk and associating it with a plex. The plex then contains both a log and data subdisks.

## Dirty Bits

Only a limited number of bits can be marked dirty in the log at any time. The dirty bit for a region is not cleared immediately after writing the data to the region. Instead, it remains marked as dirty until the corresponding volume region becomes the least recently used. If a bit for a given region is already marked dirty and another write to the same region occurs, it is not necessary to write the log to the disk before the write operation can occur.

## Sequential DRL

Some volumes, such as those used for database replay logs, are written sequentially and do not benefit from delayed cleaning of the DRL bits. For these volumes, *sequential DRL* can be used to limit the number of dirty regions. This allows for faster recovery should a crash occur. However, if applied to volumes that are written to randomly, sequential DRL can be a performance bottleneck as it limits the number of parallel writes that can be carried out.

The maximum number of dirty regions allowed for sequential DRL is controlled by the tunable `voldrl_max_seq_dirty` as described in the description of “[voldrl\\_max\\_seq\\_dirty](#)” on page 234.

---

**Note** DRL adds a small I/O overhead for most write access patterns.

---

For details of how to configure DRL and sequential DRL, see “[Adding a DRL Log to a Mirrored Volume](#)” on page 147.

## FastResync (FR) and Snapshots

The FastResync feature (also called fast mirror resynchronization or FR) performs quick and efficient resynchronization of stale mirrors (a mirror that is not synchronized). This increases the efficiency of the VxVM snapshot mechanism, and improves the performance of operations such as backup and decision support. Typically, these operations require that the volume is quiescent, and that they are not impeded by updates to the volume by other activities on the system. To achieve these goals, the snapshot mechanism in VxVM creates an exact copy of a primary volume at an instant in time. After a snapshot is taken, it can be accessed independently of the volume from which it was taken. In a shared/clustered VxVM environment, it is possible to eliminate the resource contention and performance overhead of using the snapshot simply by accessing it from a different machine.

For details of how to configure FastResync, see “[Adding a RAID-5 Log](#)” on page 148.

## FastResync Enhancements

FastResync provides two fundamental enhancements to VxVM. The first, *resynchronization*, optimizes the mirror resynchronization process, and the second, *reconnection*, extends the snapshot model to provide a method by which snapshots can be refreshed and re-used rather than discarded.

- ◆ *Resynchronization* keeps track of the data store updates missed by mirrors that were unavailable at the time the updates were applied. When a mirror returns to service, only the updates missed by that mirror need to be re-applied to resynchronize the mirror. This process generally requires much less effort than the traditional method of copying the entire data store to the returning mirror.

A mirror is unavailable if it has been *detached* from its volume, either automatically by VxVM as the result of an error, or directly by an administrator using a VxVM utility such as `vxplex` or `vxassist`. A *returning mirror* is a mirror that was previously detached and is in the process of being re-attached to its original volume as the result of the `vxrecover` or `vxplex att` operation.



FastResync does not alter the traditional mirror failure and repair administrative model. The only visible effect is that typical mirror repair operations conclude more quickly.

You can enable or disable FastResync on a per-volume basis, and also check on the progress of the fast resynchronization.

- ◆ *Reconnection* augments the existing snapshot usage model. Without FastResync, the snapshot mechanism would create an entire independent copy of a volume. Once created, the original volume and the snap volume are completely independent of each other, and their data can quickly diverge.

The snapback enhancement to Fast Mirror Reconnect makes it possible to re-associate a snapshot volume with its original peer. This reduces the work-load required to perform cyclic operations that rely heavily upon the snapshot functionality of VxVM.

## The Enhanced Snapshot Model

The FastResync snapshot enhancements introduced in VxVM 3.1 extend the snapshot model as shown in “[FastResync Enhancements to the Snapshot Model](#)” on page 39. This depicts the transitions introduced by the `snapback` and `snapclear` commands to `vxassist`.

The `vxassist snapstart` command creates a temporary mirror plex, MP, to be used for the snapshot, and attaches it to the volume, OV.

When the attachment is complete, the `vxassist snapshot` command is used to create a new snapshot volume, SV, by taking the temporary mirror, MP, to use as its data plex, SP. This command behaves as in previous releases with the addition of creating an association between the original volume, OV, and the snapshot volume, SV.

The command, `vxassist snapback`, can be used to return the snapshot plex, SP, to the original volume, OV, from which it was snapped. This is usual if a snapshot was taken to create an online backup.

Alternatively, the `vxassist snapclear` command can be used to break the association between the original volume, OV, and the snapshot volume, SV, and clears the FastResync map. The snapshot volume then has an existence independent of the original volume. This is useful if you know that a snapshot never needs to return to the original volume from which it was created. This is usual if a copy of the volume is needed for such applications as decision support or developmental testing.



## FastResync Enhancements to the Snapshot Model

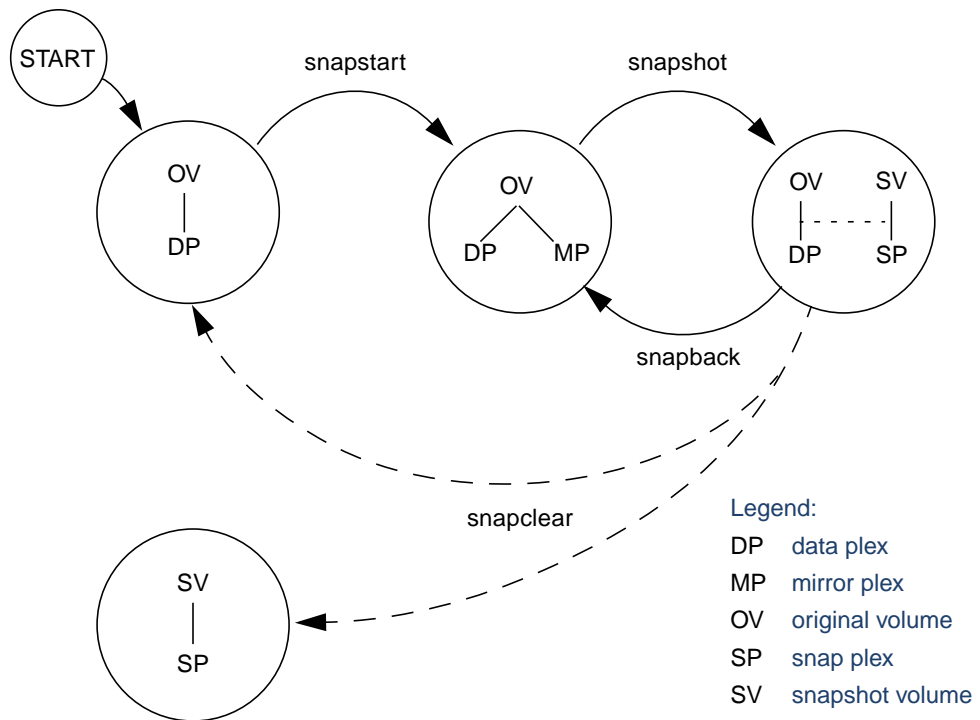

For more information about taking snapshots of a volume, see [“Backing Up Volumes Online Using Snapshots”](#) on page 159, and the `vxassist(1M)` manual page.

## How FastResync Works with Snapshots

The snapshot feature of VxVM takes advantage of FastResync change tracking to record updates to the original volume after a snapshot plex is created. After a snapshot is taken, the `snapback` option is used to reattach the snapshot plex. Provided that FastResync is enabled on a volume before the snapshot is taken, and is not disabled at any time before the snapshot is reattached, the changes that FastResync records are used to resynchronize the volume during the `snapback`. This considerably reduces the time needed to resynchronize the volume.

FastResync uses a map in memory to implement change tracking. Each bit in the map represents a contiguous number of blocks in a volume's address space. The kernel tunable `vol_fmr_logsz` can be used to limit the maximum size in blocks of the map as described on page 230.



**Note** From VxVM 3.1 onward, FastResync change maps are allocated in memory. They do not reside on disk or in persistent store, unlike a DRL. This has the advantage that updates to the FastResync map have little impact on I/O performance, as no disk updates need to be performed. However, if the system is rebooted, the information in the map is lost, and full resynchronization is necessary on snapback.

---

## Additional Snapshot Features

To make it easier to create snapshots of several volumes at the same time, the snapshot option accepts more than one volume name as its argument. By default, each replica volume is named `SNAPnumber-volume`, where `number` is a unique serial number, and `volume` is the name of the volume being snapshot. This default can be overridden by using the option `-o name=pattern`, as described on the `vxassist(1M)` manual page.

To snapshot all the volumes in a single disk group, specify the option `-o allvols` to `vxassist`. However, this fails if any of the volumes in the disk group do not have a complete snapshot plex.

It is also possible to take several snapshots of the same volume. A new FastResync change map is produced for each snapshot taken to minimize the resynchronization time for each snapshot.

The snapshot plex can be chosen as the preferred copy of the data when performing a snapback. Adding `-o resyncfromreplica` to the `snapback` option copies the data on the snapshot (replica) plex onto all the mirrors attached to the original volume. By default, the data on the original volume is copied to the snapshot plex.

It is possible to grow the replica volume, or the original volume, and still use FastResync. Growing the volume extends the map that FastResync uses to track changes to the original volume. This can change either the size of the map, or the size of the region represented by each bit in the map. In either case, the part of the map that corresponds to the grown area of the volume is marked as “dirty” so that this area is resynchronized. The snapshot operation fails if the snapshot attempts to create an incomplete snapshot plex. In such cases, it is necessary to grow the replica volume, or the original volume, before the `snapback` option is run. Growing the two volumes separately can lead to a snapshot that shares physical disks with another mirror in the volume. To prevent this, grow the volume after the `snapback` command is complete.

## FastResync Limitations

The following limitations apply to FastResync:

- ◆ FastResync is not supported for RAID-5 volumes.
- ◆ When a subdisk is relocated, the entire plex is marked “dirty” and a full resynchronization becomes necessary.
- ◆ Enabling FastResync on a layered volume enables only the parent volume (the top volume). FastResync must be enabled on each individual subvolume in a layered volume.
- ◆ Any operation that changes the layout of the replica volume can mark the FastResync change map for that snapshot “dirty” and require a full resynchronization during snapback. Operations that cause this include subdisk split, subdisk move, and online relayout of the replica. It is safe to perform these operations after the snapshot is completed. For more information, see the `vxvol (1M)`, `vxassist (1M)`, and `vxplex (1M)` manual pages.

## VxSmartSync Recovery Accelerator

The VxSmartSync™ Recovery Accelerator is available on some systems. VxSmartSync for Mirrored Oracle® Databases is a collection of features that speed up the resynchronization process (known as *resilvering*) for volumes used in with the Oracle Universal Database™. These features use an extended interface between VxVM volumes and the database software to avoid unnecessary work during mirror resynchronization. Oracle automatically takes advantage of VxSmartSync when it is available.

You must configure volumes correctly to use VxSmartSync. For VxVM, there are two types of volumes used by the database, as follows:

- ◆ *Redo log volumes* contain redo logs of the database.
- ◆ *Data volumes* are all other volumes used by the database (control files and tablespace files).

VxSmartSync works with these two types of volumes differently, and they must be configured correctly to take full advantage of the extended interfaces. The only difference between the two types of volumes is that redo log volumes have dirty region logs, while data volumes do not.



## Data Volume Configuration

The recovery takes place when the database software is started, not at system startup. This reduces the overall impact of recovery when the system reboots. Because the recovery is controlled by the database, the recovery time for the volume is the resilvering time for the database (that is, the time required to replay the redo logs).

Because the database keeps its own logs, it is not necessary for VxVM to do logging. Data volumes should be configured as mirrored volumes *without* dirty region logs. In addition to improving recovery time, this avoids any run-time I/O overhead due to DRL which improves normal database write access.

## Redo Log Volume Configuration

A *redo log* is a log of changes to the database data. Because the database does not maintain changes to the redo logs, it cannot provide information about which sections require resilvering. Redo logs are also written sequentially, and since traditional dirty region logs are most useful with randomly-written data, they are of minimal use for reducing recovery time for redo logs. However, VxVM can reduce the number of dirty regions by modifying the behavior of its Dirty Region Logging feature to take advantage of sequential access patterns. Sequential DRL decreases the amount of data needing recovery and reduces recovery time impact on the system.

The enhanced interfaces for redo logs allow the database software to inform VxVM when a volume is to be used as a redo log. This allows VxVM to modify the DRL behavior of the volume to take advantage of the access patterns. Since the improved recovery time depends on dirty region logs, redo log volumes should be configured as mirrored volumes *with* sequential DRL.

For details of how to configure sequential DRL, see “[Adding a DRL Log to a Mirrored Volume](#)” on page 147.

## Hot-Relocation

*Hot-relocation* allows a system to react automatically to I/O failures on redundant (mirrored or RAID-5) VM objects and restore redundancy and access to those objects. VxVM detects I/O failures on objects and relocates the affected subdisks. The subdisks are relocated to disks designated as *spare disks* and/or free space within the disk group. VxVM then reconstructs the objects that existed before the failure and makes them accessible again.

When a partial disk failure occurs (that is, a failure affecting only some subdisks on a disk), redundant data on the failed portion of the disk is relocated. Existing volumes are on the unaffected portions of the disk remain accessible. For further details, see “[Administering Hot-Relocation](#)” on page 167.

## Introduction

This chapter describes the operations for managing disks used by the VERITAS Volume Manager (VxVM). This includes placing disks under VxVM control, initializing disks, encapsulating disks, mirroring the root disk, and removing and replacing disks.

---

**Note** Most VxVM commands require superuser or equivalent privileges.

---

## Disk Devices

When a disk is placed under VxVM control, a VM disk is assigned to it. You can use a symbolic *disk name* (also known as a *disk media name*), for example, `disk0`, to refer to a VM disk for the purposes of administration. If you do not assign a disk name, it defaults to `disk##` if the disk is being added to `rootdg` (where `##` is a sequence number). Otherwise, the default disk name is `groupname##`, where *groupname* is the name of the disk group to which the disk is added. Your system may use a device name that differs from the examples.

When performing disk administration, it is important to understand the difference between a *disk name* and a *device name*. The *device name* (sometimes referred to as *devname* or *disk access name*) defines where the disk is located in a system. The syntax of a device name is `c#t#d#s#`, where `c#` represents a host bus adapter, `t#` is the controller target ID, `d#` identifies a disk on a controller, and `s#` represents a partition (or *slice*) on the disk.

---

**Note** The slice `s2` represents the entire disk. The entire disk is also implied if the slice is omitted from the device name.

---

The boot disk (which contains the root file system and is used when booting the system) is often identified to VxVM by the device name `c0t0d0`.

---

**Note** The full pathname of a device is `/dev/vx/[r]dmp/devicename`. In this document, only the device name is listed and `/dev/vx/[r]dmp` is assumed.

---



A VM disk has two regions:

- ◆ *private region*—a small area where configuration information is stored. A disk label and configuration records are stored here.
- ◆ *public region*—an area that covers the remainder of the disk and is used to store subdisks (and allocate storage space).

Three basic disk types are used by VxVM:

- ◆ *sliced*—the public and private regions are on different disk partitions.
- ◆ *simple*—the public and private regions are on the same disk area (with the public area following the private area).
- ◆ *nopriv*—there is no private region (only a public region for allocating subdisks).

VxVM initializes each new disk with the fewest number of partitions possible. For VM disks of type `sliced`, it configures partition `s3` as the private region, `s4` as the public region, and `s2` as the entire physical disk.

Two classes of disk devices can be used with VxVM: standard devices and special devices. Use of special devices applies only to systems that support dynamic multipathing (DMP). Special devices are physical disks connected to a system that may have more than one physical access path. Such devices are represented by *metadevices*. The access paths depend on whether the disk is a single disk, or part of a multiported disk array connected to the system. The `vxdisk` utility can be used to display the paths subsumed by a metadevice, and to display the status of each path (for example, whether it is enabled or disabled).

## Placing Disks Under VxVM Control

When you add a disk to a system that is running VxVM, you need to put the disk under VxVM control so that VxVM can control the space allocation on the disk. Unless another disk group is specified, VxVM places new disks in the default disk group, `rootdg`.

The method by which you place a disk under VxVM control depends on the circumstances:

- ◆ If the disk is new, it must be *initialized* and placed under VxVM control.

---

**Note** Initialization destroys existing data on disks.

---

- ◆ If the disk is not needed immediately, it can be initialized (but not added to a disk group) and reserved for future use. To do this, enter `none` when asked to name a disk group. Do not confuse this type of “spare disk” with a hot-relocation spare disk.
- ◆ If the disk was previously initialized for future use by VxVM, it can be reinitialized and placed under VxVM control.

- ◆ If the disk was previously in use, but not under VxVM control, you may wish to preserve existing data on the disk while still letting VxVM take control of the disk. This can be accomplished using *encapsulation*.

---

**Note** Encapsulation preserves existing data on disks.

---

- ◆ Multiple disks on one or more controllers can be placed under VxVM control simultaneously. Depending on the circumstances, all of the disks may not be processed the same way.
- ◆ When initializing or encapsulating multiple disks at once, it is possible to exclude certain disks or certain controllers.

To exclude disks, list the names of the disks to be excluded in the file `/etc/vx/disks.exclude` before the initialization or encapsulation. The following is an example of the contents of a `disks.exclude` file:

```
c0t1d0
```

You can exclude all disks on specific controllers from initialization or encapsulation by listing those controllers in the file `/etc/vx/cntrls.exclude`. The following is an example of the contents of a `cntrls.exclude` file:

```
c0
```

---

**Note** Only the `vxinstall` and `vxdiskadm` commands use the contents of the `/etc/vx/disks.exclude` and `/etc/vx/cntrls.exclude` files.

---

The following sections provide detailed examples of how to use the `vxdiskadm` utility to place disks under VxVM control in various ways and circumstances.

---

**Note** A disk must be formatted (using the `format` command, for example) or added to the system (using the `diskadd` command, for example) before it can be placed under VxVM control. If you attempt to place an unformatted disk under VxVM control through the `vxdiskadm` utility, the initialization begins as normal, but quits with a message that the disk does not appear to be valid and may not be formatted. If you receive this message, format the disk properly and then attempt to place the disk under VxVM control again.

---

## Installing and Formatting the Disk Media

Depending on the hardware capabilities of your disk media and of your system, you may either need to shut down and power off your system before installing the disk media, or you may be able to hot-insert the disk media into the live system. Many operating systems



can detect the presence of the new disks on being rebooted. If the disks are inserted while the system is live, you may need to enter an operating system-specific command (such as `diskadd`) to notify the system.

If the disks require low- or intermediate-level formatting before use, use the operating system-specific `format` command to do this.

---

**Note** SCSI disks are usually preformatted. Reformatting is needed only if the existing formatting has become damaged.

---

## Adding a Disk to VxVM

Formatted disks being placed under VxVM control may be new or previously used outside VxVM. The set of disks can consist of all disks on the system, all disks on a controller, selected disks, or a combination thereof.

Depending on the circumstances, all of the disks may not be processed in the same way. For example, some may be initialized, while others may be encapsulated.

---

**Note** Initialization does not preserve data on disks.

---

When initializing or encapsulating multiple disks at one time, it is possible to exclude certain disks or certain controllers. To exclude disks, list the names of the disks to be excluded in the file `/etc/vx/disks.exclude` before the initialization or encapsulation. You can exclude all disks on specific controllers from initialization or encapsulation by listing those controllers in the file `/etc/vx/cntrls.exclude`.

Initialize disks for VxVM use as follows:

1. Select menu item 1 (Add or initialize one or more disks) from the `vxdiskadm` main menu.
2. At the following prompt, enter the disk device name of the disk to be added to VxVM control (or enter `list` for a list of disks):

```
Add or initialize disks
Menu: VolumeManager/Disk/AddDisks
```

```
Use this operation to add one or more disks to a disk group.
You can add the selected disks to an existing disk group or to
a new disk group that will be created as a part of the
operation. The selected disks may also be added to a disk
group as spares. The selected disks may also be initialized
without adding them to a disk group leaving the disks
available for use as replacement disks.
```



More than one disk or pattern may be entered at the prompt. Here are some disk selection examples:

```
all:      all disks
c3 c4t2:all disks on both controller 3 and controller
        4,target 2
c3t4d0: a single disk
```

Select disk devices to add:  
[<pattern-list>,all,list,q,?]

<pattern-list> can be a single disk, or a series of disks and/or controllers (with optional targets). If <pattern-list> consists of multiple items, separate them using white space, for example:

```
c3t0d0 c3t1d0 c3t2d0 c3t3d0
```

specifies four disks at separate target IDs on controller 3.

If you enter **list** at the prompt, the `vxdiskadm` program displays a list of the disks available to the system:

DEVICE	DISK	GROUP	STATUS
c0t0d0	disk01	rootdg	online
c0t1d0	disk02	rootdg	online
c0t2d0	disk03	rootdg	online
c0t3d0	-	-	online
c1t0d0	disk10	rootdg	online
c1t0d1	-	-	error
.			
.			
.			
c3t0d0	-	-	error
c3t1d0	disk33	rootdg	online
c3t2d0	disk34	rootdg	online
c3t3d0	disk35	rootdg	online

Select disk devices to add:  
[<pattern-list>,all,list,q,?]

The phrase `error` in the `STATUS` line indicates that a disk has not yet been added to VxVM control. These disks may or may not have been initialized by VxVM previously. Disks that are listed as `online` with a disk name and disk group are already under VxVM control.

Enter the device name or pattern of the disks that you want to initialize at the prompt and press Return.

### 3. To continue with the operation, enter **y** (or press Return) at the following prompt:

Here are the disks selected. Output format: [Device]



*list of device names*

Continue operation? [y,n,q,?] (default: y) **y**

4. At the following prompt, specify the disk group to which the disk should be added, **none** to reserve the disks for future use, or press Return to accept rootdg:

You can choose to add these disks to an existing disk group, a new disk group, or you can leave these disks available for use by future add or replacement operations. To create a new disk group, select a disk group name that does not yet exist. To leave the disks available for future use, specify a disk group name of "none".

Which disk group [<group>,none,list,q,?] (default: rootdg)

5. If you specified the name of a disk group that does not already exist, vxdiskadm prompts for confirmation that you really want to create this new disk group:

There is no active disk group named anotherdg.

Create a new group named *disk group name*? [y,n,q,?] (default: y) **y**

6. At the following prompt, either press Return to accept the default disk name or enter **n** to allow you to define your own disk names:

Use default disk names for the disks? [y,n,q,?] (default: y)

7. When prompted whether the disks should become hot-relocation spares, enter **n** (or press Return):

Add disks as spare disks for *disk group name*? [y,n,q,?] (default: n) **n**

8. When prompted whether to exclude the disks from hot-relocation use, enter **n** (or press Return).

Exclude disk from hot-relocation use? [y,n,q,?] (default: n) **n**

9. To continue with the operation, enter **y** (or press Return) at the following prompt:

The selected disks will be added to the disk group *disk group name* with default disk names.

*list of device names*

Continue with operation? [y,n,q,?] (default: y) **y**

10. The following prompt lists any disks that have already been initialized for use by VxVM; enter **y** to indicate that all of these disks should now be used:

The following disk devices appear to have been initialized already. The disks are currently available as replacement disks.



Output format: [Device]

*list of device names*

Use these devices? [Y,N,S(elect),q,?] (default: Y) **Y**

Note that this prompt allows you to indicate “yes” or “no” for *all* of these disks (**Y** or **N**) or to select how to process each of these disks on an individual basis (**S**).

If you are sure that you want to reinitialize all of these disks, enter **Y** at the following prompt:

The following disks you selected for use appear to already have been initialized for the Volume Manager. If you are certain the disks already have been initialized for the Volume Manager, then you do not need to reinitialize these disk devices.

Output format: [Device]

*list of device names*

Reinitialize these devices? [Y,N,S(elect),q,?] (default: Y) **Y**

- 11.** `vxdiskadm` may now indicate that one or more disks is a candidate for encapsulation. Encapsulation allows you to add an active disk to VxVM control and preserve the data on that disk. If you want to preserve the data on the disk, enter **y**. If you are sure that there is no data on the disk that you want to preserve, enter **n** to avoid encapsulation.

The following disk device has a valid VTOC, but does not appear to have been initialized for the Volume Manager. If there is data on the disk that should NOT be destroyed you should encapsulate the existing disk partitions as volumes instead of adding the disk as a new disk.

Output format: [Device]

*device name*

Encapsulate this device? [y,n,q,?] (default: y)

If you choose not to encapsulate the disk, `vxdiskadm` asks if you want to initialize the disk instead, enter **y**:

Instead of encapsulating, initialize? [y,n,q,?] (default: n) **y**

`vxdiskadm` now confirms those disks that are being initialized and added to VxVM control with messages similar to the following. In addition, you may be prompted to perform surface analysis.

Initializing device *device name*.

.  
.  
.



Adding disk device `device name` to disk group `disk group name` with disk name `disk name`.

.  
. .  
.

- 12.** `vxdiskadm` next confirms the device names of any disks that you selected for encapsulation and prompts you for permission to proceed with this. Enter **y** (or press Return) to continue encapsulation:

The following disk device has been selected for encapsulation.

Output format: [Device]

*device name*

Continue with encapsulation? [y,n,q,?] (default: y) **y**

`vxdiskadm` now displays an encapsulation status and informs you that you must perform a shutdown and reboot as soon as possible:

The disk device `c3t0d0` will be encapsulated and added to the disk group `rootdg` with the disk name `disk38`.

The first stage of encapsulation has completed successfully. You should now reboot your system at the earliest possible opportunity.

The encapsulation will require two or three reboots which will happen automatically after the next reboot. To reboot execute the command:

```
shutdown -g0 -y -i6
```

This will update the `/etc/vfstab` file so that volume devices are used to mount the file systems on this disk device. You will need to update any other references such as backup scripts, databases, or manually created swap devices.

- 13.** At the following prompt, indicate whether you want to continue to initialize more disks (**y**) or return to the `vxdiskadm` main menu (**n**):

Add or initialize other disks? [y,n,q,?] (default: n)

## Reinitializing a Disk

You can reinitialize a disk that has previously been initialized for use by VxVM by putting it under VxVM control as you would a new disk. See “[Adding a Disk to VxVM](#)” on page 46 for details.



---

**Note** Reinitialization does not preserve data on the disk. If you want to reinitialize the disk, make sure that it does not contain data that should be preserved.

---

If the disk you want to add has been used before, but not with VxVM, encapsulate the disk and preserve its information.

## Using `vxdiskadd` to Place a Disk Under Control of VxVM

As an alternative to `vxdiskadm`, you can use the `vxdiskadd` command to put a disk under VxVM control. For example, to initialize the second disk on the first controller, use the following command:

```
# vxdiskadd c0t1d0
```

The `vxdiskadd` command examines your disk to determine whether it has been initialized and also checks for disks that can be encapsulated (see “[Using vxdisk for Encapsulation](#)” on page 58), disks that have been added to VxVM, and for other conditions.

---

**Note** If you are adding an uninitialized disk, warning and error messages are displayed on the console during the `vxdiskadd` command. Ignore these messages. These messages should not appear after the disk has been fully initialized; the `vxdiskadd` command displays a success message when the initialization completes.

---

The interactive dialog for adding a disk using `vxdiskadd` is similar to that for `vxdiskadm`, described in “[Adding a Disk to VxVM](#)” on page 46.

## Rootability

VxVM can place various files from different systems (for example, the root file system, `swap` device and `usr` file system) under VxVM control. This is called *rootability*. The *root disk* (that is, the disk containing the root file system) can be put under VxVM control through the process of *encapsulation*.

Encapsulation converts existing partitions on that disk to volumes. Once under VxVM control, the `root` and `swap` devices appear as volumes and provide the same characteristics as other VxVM volumes. A volume that is configured for use as a swap area is referred to as a *swap volume*, and a volume that contains the root file system is referred to as a *root volume*.



It is possible to mirror the `rootvol`, and `swapvol` volumes, as well as other parts of the root disk that are required for a successful boot of the system (for example, `/usr`). This provides complete redundancy and recovery capability in the event of disk failure. Without VxVM rootability, the loss of the `root`, `swap`, or `usr` partition prevents the system from being booted from surviving disks.

Mirroring disk drives critical to booting ensures that no single disk failure renders the system unusable. A suggested configuration is to mirror the critical disk onto another available disk (using the `vxdiskadm` command). If the disk containing `root` and `swap` partitions fails, the system can be rebooted from a disk containing mirrors of these partitions. For more information on system recovery procedures for the boot disk, see the chapter “Recovery from Boot Disk Failure” in the *VERITAS Volume Manager Troubleshooting Guide*.

## Booting root Volumes

When the operating system is booted, the `root` file system and `swap` area must be available for use before the `vxconfigd` daemon can load the VxVM configuration or start any volumes. During system startup, the operating system must see the `rootvol` and `swapvol` volumes as regular partitions so that it can access them as ordinary disk partitions.

Due to this restriction, each of the `rootvol` and `swapvol` plexes must be created from contiguous space on a disk that is mapped to a single partition. It is not possible to stripe, concatenate or span the plex of a `rootvol` or `swapvol` volume that is used for booting. Any mirrors of these plexes that are potentially bootable also cannot be striped, concatenated or spanned.

## Boot-time Volume Restrictions

The `rootvol`, `swapvol`, and `usr` volumes differ from other volumes in that they have very specific restrictions on the configuration of the volumes:

- ◆ The root volume (`rootvol`) must exist in the default disk group, `rootdg`. Although other volumes named `rootvol` can be created in disk groups other than `rootdg`, only the `rootvol` in `rootdg` can be used to boot the system.
- ◆ A `rootvol` volume has a specific minor device number: minor device 0. Also, `swapvol` has minor device number 1. The `usr` volume does not have a specific minor device number. For more information, see the chapter “Recovery from Boot Disk Failure” in the *VERITAS Volume Manager Troubleshooting Guide*.

- ◆ Restricted mirrors of `rootvol`, `var`, `usr` and `swapvol` devices have “overlay” partitions created for them. An overlay partition is one that exactly includes the disk space occupied by the restricted mirror. During boot, before the `rootvol`, `var`, `usr` and `swapvol` volumes are fully configured, the default volume configuration uses the overlay partition to access the data on the disk.
- ◆ Although it is possible to add a striped mirror to a `rootvol` device for performance reasons, you cannot stripe the primary plex or any mirrors of `rootvol` that may be needed for system recovery or booting purposes if the primary plex fails.
- ◆ `rootvol` and `swapvol` cannot be spanned or contain a primary plex with multiple noncontiguous subdisks. You cannot grow or shrink any volume associated with an encapsulated bootdisk (`rootvol`, `usr`, `var`, `opt`, `swapvol`, and so on) because these map to a physical underlying partition on the disk and must be contiguous. A workaround is to unencapsulate the bootdisk, repartition the bootdisk as desired (growing or shrinking partitions as needed), and then re-encapsulating.
- ◆ When mirroring parts of the boot disk, the disk being mirrored to must be large enough to hold the data on the original plex, or mirroring may not work.
- ◆ `rootvol`, `swapvol` and `usr` cannot be dirty region logging (DRL) volumes.

In addition to these requirements, it is a good idea to have at least one contiguous, (cylinder-aligned if appropriate) mirror for each of the volumes for `root`, `usr`, `var`, `opt` and `swap`. This makes it easier to convert these from volumes back to regular disk partitions (during an operating system upgrade, for example).

## Encapsulating a Disk for Use in VxVM

This section describes how to encapsulate a disk for use in VxVM. Encapsulation preserves any existing data on the disk when the disk is placed under VxVM control.

---

**Caution** Encapsulating a disk requires that the system be rebooted several times. Schedule performance of this procedure for a time when this does not inconvenience users.

---

To reduce the chance of encapsulation failure, make sure that the disk:

- ◆ has a small amount of free space (at the beginning or end of the disk) that does not belong to any partition
- ◆ has two free partitions
- ◆ has an `s2` slice that represents the whole disk

To encapsulate a disk for use in VxVM, use the following procedure:



1. Select menu item 2 (Encapsulate one or more disks) from the vxdiskadm main menu.

---

**Note** Your system may use device names that differ from the examples shown here.

---

At the following prompt, enter the disk device name for the disks to be encapsulated:

```
Encapsulate one or more disks
Menu: VolumeManager/Disk/Encapsulate
```

```
Use this operation to convert one or more disks to use the
Volume Manager. This adds the disks to a disk group and
replaces existing partitions with volumes. Disk encapsulation
requires a reboot for the changes to take effect.
```

```
More than one disk or pattern may be entered at the prompt.
Here are some disk selection examples:
```

```
all:      all disks
c3 c4t2:  all disks on both controller 3 and controller
          4, target 2
c3t4d0:   a single disk
```

```
Select disk devices to encapsulate:
[<pattern-list>,all,list,q,?] c2t5d0
```

Where *<pattern-list>* can be a single disk, or a series of disks and/or controllers (with optional targets). If *<pattern-list>* consists of multiple items, those items must be separated by white space.

If you do not know the address (device name) of the disk to be encapsulated, enter **l** or **list** at the prompt for a complete listing of available disks.

2. To continue the operation, enter **y** (or press Return) at the following prompt:

```
Here is the disk selected. Output format: [Device]
```

```
c2t5d0
```

```
Continue operation? [y,n,q,?] (default: y) y
```

3. To add the disk to the default disk group, rootdg, press Return at the following prompt:

```
You can choose to add this disk to an existing disk group or to
a new disk group. To create a new disk group, select a disk
group name that does not yet exist.
```

```
Which disk group [<group>,list,q,?] (default: rootdg)
```



4. At the following prompt, either press Return to accept the default disk name or enter a disk name:

```
Use a default disk name for the disk? [y,n,q,?] (default: y)
```

5. To continue with the operation, enter **y** (or press Return) at the following prompt:

```
The selected disks will be encapsulated and added to the rootdg  
disk group with default disk names.
```

```
c2t5d0
```

```
Continue with operation? [y,n,q,?] (default: y) y
```

6. To confirm that encapsulation should proceed, enter **y** (or press Return) at the following prompt:

```
The following disk has been selected for encapsulation.  Output  
format: [Device]
```

```
c2t5d0
```

```
Continue with encapsulation? [y,n,q,?] (default: y) y
```

A message similar to the following confirms that the disk is being encapsulated for use in VxVM and tells you that a reboot is needed:

```
The disk device c2t5d0 will be encapsulated and added to the  
disk group rootdg with the disk name disk01.
```

```
The c2t5d0 disk has been configured for encapsulation.
```

```
The first stage of encapsulation has completed successfully.  
You should now reboot your system at the earliest possible  
opportunity.
```

```
The encapsulation will require two or three reboots which  
will happen automatically after the next reboot.  To reboot  
execute the command:
```

```
shutdown -g0 -y -i6
```

```
This will update the /etc/vfstab file so that volume devices  
are used to mount the file systems on this disk device.  You  
will need to update any other references such as backup  
scripts, databases, or manually created swap devices.
```

---

**Note** The original /etc/vfstab file is saved as /etc/vfstab.prevm.

---



7. At the following prompt, indicate whether you want to encapsulate more disks (y) or return to the `vxdiskadm` main menu (n):

```
Encapsulate other disks? [y,n,q,?] (default: n) n
```

## Failure of Disk Encapsulation

Under some circumstances, encapsulation of a disk can fail. Usually this is because there is not enough free space available on the disk to accommodate VxVM. If this happens, the procedure outlined above ends abruptly with an error message similar to the following:

```
The encapsulation operation failed with the following error:
```

```
It is not possible to encapsulate device, for the following reason:  
<vxvm:vx slicer: ERROR: Unsupported disk layout.>
```

See the section, “[Using vxdisk for Encapsulation](#)” on page 58, for advice about what you can do if this occurs.

## Encapsulating and Mirroring the root Disk

VxVM allows you to mirror the root volume and other areas needed for booting onto another disk. This makes it possible to recover from failure of your `root` disk by replacing it with one of its mirrors.

---

**Note** Use the `format` or `fdisk` commands to obtain a printout of the `root` disk partition table before you encapsulate the root disk. For more information, see the appropriate manual pages. You will need this information should you subsequently need to recreate the original root disk. See, for example, the section “Repairing root or /usr File Systems on Mirrored Volumes” in the chapter “Recovery from Boot Disk Failure” in the *VERITAS Volume Manager Troubleshooting Guide*.

---

To mirror your `root` disk onto another disk:

1. Choose a disk that is at least as large as the existing root disk.
2. If the selected disk is not already under VxVM control, use either the `vxdiskadd` or `vxdiskadm` command to add it to VxVM in the `rootdg` disk group.
3. Execute the following command:

```
# /etc/vx/bin/vxrootmir alternate_disk
```

where *alternate\_disk* is the disk name of the disk that will mirror the root disk. (Alternatively, use the `vxdiskadm` command or the VERITAS Volume Manager Storage Administrator (VMSA) to create a mirror of the `root` disk. These automatically invoke `vxrootmir` if the mirroring operation is performed on the `root` disk.)

`vxrootmir` creates a mirror for `rootvol` (the volume for the `root` file system on an alternate disk). The alternate `root` disk is configured to enable booting from it if the primary `root` disk fails.

4. Set the EEPROM variable `use-nvramrc?` to `true` to use the VxVM boot disk aliases. These identify a mirror of the `root` disk from which the system can be booted if a replacement is needed. If this variable is set to `false`, you must determine which disks are bootable yourself. To set this variable to `true`, use the following command:

```
# eeprom use-nvramrc?=true
```

The variable `use-nvramrc?` may also be set at the `ok` boot prompt:

```
ok use-nvramrc?=true
```

## Mirroring Other File Systems on the root Disk

There may be other volumes on the boot disk, such as volumes for `/home` or `/tmp` file systems. These can be mirrored separately using the `vxassist` utility. For example, if you have a `/home` file system on a volume `homevol`, you can mirror it to *alternate\_disk* using the command:

```
# vxassist mirror homevol alternate_disk
```

If you do not have space for a copy of some of these file systems on your alternate boot disk, you can mirror them to other disks. You can also span or stripe these other volumes across other disks attached to your system.

To list all volumes on your primary boot disk, use the command:

```
# vxprint -t -v -e+='aslist.aslist.sd_disk="boot_disk"'
```

To mirror all of the concatenated volumes on this disk to your alternate boot disk, use the command:

```
# /etc/vx/bin/vxmirror boot_disk alternate_disk
```

## Defining Alternate Boot Disks

Use the `devalias` command at the boot prompt to discover the alternate disks from which the system may be booted:

```
ok devalias
```



If required, you can define an alias for the alternate boot disk by entering the following command:

```
ok nvramrc=devalias vx-altboot
```

where *altboot* is the disk name of the alternate disk from which the system can be booted.

Alternatively, if the system is already up and running, enter the following command to define an alternate boot disk:

```
# eeprom nvramrc=devalias vx-altboot
```

## Using vxdisk for Encapsulation

Encapsulation converts existing partitions on a specified disk to volumes. If any partitions contain file systems, their `/etc/vfstab` entries are modified so the file systems are mounted on volumes instead.

Disk encapsulation requires that free space be available on the disk for storing VxVM identification and configuration information. This free space cannot be included in any other partitions. (See the *VERITAS Volume Manager Installation Guide* and the `vxencap(1M)` manual page for more information.)

You can encapsulate a disk that does not have space available for the VxVM private region partition by using the `vxdisk` utility. This is done by using `nopriv` devices that do not have private regions.

To create a `nopriv` device:

1. If it does not exist already, set up a partition on the disk for the area that you want to access using VxVM.
2. Use the following command to map a VM disk to the partition:

```
# vxdisk define partition-device type=nopriv
```

where *partition-device* is the basename of the device in the `/dev/dsk` directory. For example, to map partition 3 of disk device `c0t4d0`, use the following command:

```
# vxdisk define c0t4d0s3 type=nopriv
```

To create volumes for other partitions on the disk:

1. add the partition to a disk group
2. determine where the partition resides within the encapsulated partition
3. use `vxassist` to create a volume with that offset and length

---

**Note** `vxassist`, by default, reinitializes the data area of a volume that it creates. If there is data to be preserved on the partition, do not use `vxassist`. Instead, create the volume with `vxmake` and start the volume with the command `vxvol init active`.

---

The drawback with using `nopriv` devices is that VxVM cannot track changes in the address or controller of the disk. Normally, VxVM uses identifying information stored in the private region on the physical disk to track changes in the location of a physical disk. Because `nopriv` devices do not have private regions and have no identifying information stored on the physical disk, tracking cannot occur.

One use of `nopriv` devices is to encapsulate a disk so that you can use VxVM to move data off the disk. When space is made available on the disk, remove the `nopriv` device can be removed, and encapsulate the disk as a standard disk device.

---

**Note** A disk group cannot be formed entirely from `nopriv` devices. This is because `nopriv` devices do not provide space for storing disk group configuration information. Configuration information must be stored on at least one disk in the disk group.

---

## Using RAM Disks with VxVM

---

**Note** This section only applies to systems which support RAM disks.

---

Some systems support creation of RAM disks. A RAM disk is a device made from system RAM that looks like a small disk device. Often, the contents of a RAM disk are erased when the system is rebooted. RAM disks that are erased on reboot prevent VxVM from identifying physical disks. This is because information stored on the physical disks (now erased on reboot) is used to identify the disk.

`nopriv` devices have a special feature to support RAM disks: a *volatile* option which indicates to VxVM that the device contents do not survive reboots. Volatile devices receive special treatment on system startup. If a volume is mirrored, plexes made from volatile devices are always recovered by copying data from nonvolatile plexes.

---

**Note** To use a RAM disk with VxVM, block and character device nodes must exist for the RAM disk, for example, `/dev/dsk/ramd0` and `/dev/rdisk/ramd0`.

---

To define the RAM disk device to VxVM, use the following command:

```
# vxdisk define ramd0 type=nopriv volatile
```



Normally, VxVM does not start volumes that are formed entirely from plexes with volatile subdisks. That is because there is no plex that is guaranteed to contain the most recent volume contents.

Some RAM disks are used in situations where all volume contents are recreated after reboot. In these situations, you can force volumes formed from RAM disks to be started at reboot by using the following command:

```
# vxvol set startopts=norecov volume
```

This option can be used only with volumes of type `gen`. See the `vxvol(1M)` manual page for more information on the `vxvol set` operation and the `norecov` option.

## Removing Disks

You can remove a disk from a system and move it to another system if the disk is failing or has failed. Before removing the disk from the current system, you must:

1. Stop all activity by applications to volumes that are configured on the disk that is to be removed. Unmount file systems and shut down databases that are configured on the volumes.
2. Use the following command to stop the volumes:

```
# vxvol stop volume1 volume2 ...
```
3. Move the volumes to other disks or back up the volumes. To move a volume, mirror the volume on one or more other disks, then remove the original copy of the volume. If the volumes are no longer needed, they can be removed instead of moved.

Before removing a disk, make sure it contains no data, all data no longer needed, or the data can be moved to other disks. Then remove the disk using the `vxdiskadm` utility, as follows:

1. Select menu item 3 (Remove a disk) from the `vxdiskadm` main menu.

---

**Note** You must disable the disk group before you can remove the last disk in that group.

---

2. At the following prompt, enter the disk name of the disk to be removed:

```
Remove a disk
Menu: VolumeManager/Disk/RemoveDisk
```

Use this operation to remove a disk from a disk group. This operation takes a disk name as input. This is the same name that you gave to the disk when you added the disk to the disk group.

```
Enter disk name [<disk>,list,q,?] disk01
```

3. If there are any volumes on the disk, VxVM asks you whether they should be evacuated from the disk. If you wish to keep the volumes, answer **y**. Otherwise, answer **n**.

4. At the following verification prompt, press Return to continue:

```
Requested operation is to remove disk disk01 from group rootdg.  
Continue with operation? [y,n,q,?] (default: y)
```

The `vxdiskadm` utility removes the disk from the disk group and displays the following success message:

```
Removal of disk disk01 is complete.
```

You can now remove the disk or leave it on your system as a replacement.

5. At the following prompt, indicate whether you want to remove other disks (**y**) or return to the `vxdiskadm` main menu (**n**):

```
Remove another disk? [y,n,q,?] (default: n)
```

## Removing a Disk with Subdisks

You can remove a disk on which some subdisks are defined. For example, you can consolidate all the volumes onto one disk. If you use the `vxdiskadm` program to remove a disk, you can choose to move volumes off that disk. To do this, run the `vxdiskadm` program and select item 3 (Remove a disk) from the main menu.

If the disk is used by some subdisks, the following message is displayed:

```
The following subdisks currently use part of disk disk02:
```

```
home usrvol
```

```
Subdisks must be moved from disk02 before it can be removed.
```

```
Move subdisks to other disks? [y,n,q,?] (default: n)
```

If you choose **y**, then all subdisks are moved off the disk, if possible. Some subdisks are not movable. A subdisk may not be movable for one of the following reasons:



- ◆ There is not enough space on the remaining disks in the subdisk's disk group.
- ◆ Plexes or striped subdisks cannot be allocated on different disks from existing plexes or striped subdisks in the volume.

If the `vxdiskadm` program cannot move some subdisks, remove some plexes from some disks to free more space before proceeding with the disk removal operation. See [“Removing a Volume” on page 154](#) and [“Taking Plexes Offline” on page 115](#) for information on how to remove volumes and plexes.

## Removing a Disk with No Subdisks

A disk that contains no subdisks can be removed from its disk group with the following command:

```
# vxdg [-g groupname] rmdisk diskname
```

where the disk group name is only specified for a disk group other than the default, `rootdg`.

For example, to remove `disk02` from `rootdg`, use the following command:

```
# vxdg rmdisk disk02
```

If the disk has subdisks on it when you try to remove it, the following error message is displayed:

```
vxdg:Disk diskname is used by one or more subdisks
```

Use the `-k` option to the `vxdg` command to remove device assignment. Using the `-k` option allows you to remove the disk even if subdisks are present. For more information, see the `vxdg(1M)` manual page.

---

**Note** Use of the `-k` option to the `vxdg` command can result in data loss.

---

Once the disk has been removed from its disk group, you can (optionally) remove it from VxVM control completely, as follows:

```
# vxdisk rm devicename
```

For example, to remove `c1t0d0` from VxVM control, enter:

```
# vxdisk rm c1t0d0
```



## Removing and Replacing Disks

If failures are starting to occur on a disk, but the disk has not yet failed completely, you can replace the disk. This involves detaching the failed or failing disk from its disk group, followed by replacing the failed or failing disk with a new one. Replacing the disk can be postponed until a later date if necessary.

To replace a disk, use the following procedure:

1. Select menu item 4 (Remove a disk for replacement) from the `vxdiskadm` main menu.
2. At the following prompt, enter the name of the disk to be replaced (or enter `list` for a list of disks):

```
Remove a disk for replacement
Menu: VolumeManager/Disk/RemoveForReplace
```

```
Use this menu operation to remove a physical disk from a disk
group, while retaining the disk name. This changes the state
for the disk name to a removed disk. If there are any
initialized disks that are not part of a disk group, you will be
given the option of using one of these disks as a replacement.
```

```
Enter disk name [<disk>,list,q,?] disk02
```

3. When you select a disk to remove for replacement, all volumes that are affected by the operation are displayed, for example:

```
The following volumes will lose mirrors as a result of this
operation:
```

```
home src
```

```
No data on these volumes will be lost.
```

```
The following volumes are in use, and will be disabled as a result
of this operation:
```

```
mkting
```

```
Any applications using these volumes will fail future accesses.
These volumes will require restoration from backup.
```

```
Are you sure you want do this? [y,n,q,?] (default: n)
```

To remove the disk, causing the named volumes to be disabled and data to be lost when the disk is replaced, enter `y` or press Return.

To abandon removal of the disk, and back up or move the data associated with the volumes that would otherwise be disabled, enter `n` or `q` and press Return.



For example, to move the volume `mkting` to a disk other than `disk02`, use this command:

```
# vxassist move mkting !disk02
```

After backing up or moving the data in the volumes, start again from step 1 above.

4. At the following prompt, either select the device name of the replacement disk (from the list provided), press Return to choose the default disk, or enter `none` to defer replacing the disk until a later date:

```
The following devices are available as replacements:  
clt1d0s2
```

```
You can choose one of these disks now, to replace disk02.  
Select "none" if you do not wish to select a replacement disk.
```

```
Choose a device, or select "none"  
[<device>,none,q,?] (default: clt1d0s2)
```

---

**Note** Do not choose the old disk drive as a replacement even though it appears in the selection list. If necessary, you can choose to initialize a new disk.

---

5. If you chose to replace the disk in step 4, press Return at the following prompt to confirm this:

```
The requested operation is to use the initialized device  
clt1d0s2 to replace the removed or failed disk disk02 in disk  
group rootdg.
```

```
Continue with operation? [y,n,q,?] (default: y)
```

`vxdiskadm` displays the following success messages:

```
Replacement of disk disk02 in group rootdg with disk device  
clt1d0s2 completed successfully.
```

6. At the following prompt, indicate whether you want to remove another disk (`y`) or return to the `vxdiskadm` main menu (`n`):

```
Remove another disk? [y,n,q,?] (default: n)
```

If you chose to defer replacing the failed disk at step 4, see the following section, [“Replacing a Failed or Removed Disk.”](#)

---

**Note** If removing a disk causes one or more volumes to be disabled, see the section, “Restarting a Disabled Volume” in the chapter “Recovery from Hardware Failure” in the *VERITAS Volume Manager Troubleshooting Guide*, for information on how to restart a disabled volume so that you can restore its data from a backup.

---

If you wish to move hot-relocate subdisks back to a replacement disk, see “[Moving and Unrelocating Subdisks](#)” on page 176.

## Replacing a Failed or Removed Disk

Use the following procedure to replace a failed or removed disk with a new disk:

1. Select menu item 5 (Replace a failed or removed disk) from the `vxdiskadm` main menu.
2. At the following prompt, enter the name of the disk to be replaced (or enter `list` for a list of disks):

```
Replace a failed or removed disk
Menu: VolumeManager/Disk/ReplaceDisk
```

Use this menu operation to specify a replacement disk for a disk that you removed with the “Remove a disk for replacement” menu operation, or that failed during use. You will be prompted for a disk name to replace and a disk device to use as a replacement. You can choose an uninitialized disk, in which case the disk will be initialized, or you can choose a disk that you have already initialized using the Add or initialize a disk menu operation.

```
Select a removed or failed disk [<disk>,list,q,?] disk02
```

3. The `vxdiskadm` program displays the device names of the disk devices available for use as replacement disks. Your system may use a device name that differs from the examples. Enter the device name of the disk or press Return to select the default device:

```
The following devices are available as replacements:
clt0d0s2 clt1d0s2
```

You can choose one of these disks to replace `disk02`. Choose “none” to initialize another disk to replace `disk02`.

```
Choose a device, or select "none"
[<device>,none,q,?] (default: clt0d0s2)
```

4. At the following prompt, press Return to replace the disk:

```
The requested operation is to use the initialized device
clt0d0s2 to replace the removed or failed disk disk02 in disk
group rootdg.
```

```
Continue with operation? [y,n,q,?] (default: y)
```

The `vxdiskadm` program displays the following success message:



Replacement of disk disk02 in group rootdg with disk device c1t0d0s2 completed successfully.

5. At the following prompt, indicate whether you want to replace another disk (**y**) or return to the `vxdiskadm` main menu (**n**):

Replace another disk? [y,n,q,?] (default: n)

## Enabling a Physical Disk

If you move a disk from one system to another during normal system operation, VxVM does not recognize the disk automatically. The enable disk task enables VxVM to identify the disk and to determine if this disk is part of a disk group. Also, this task re-enables access to a disk that was disabled by either the disk group `deport` task or the disk device `disable` (offline) task.

To enable a disk, use the following procedure:

1. Select menu item 10 (Enable (online) a disk device) from the `vxdiskadm` main menu.
2. At the following prompt, enter the device name of the disk to be enabled (or enter `list` for a list of devices):

```
Enable (online) a disk device
Menu: VolumeManager/Disk/OnlineDisk
```

Use this operation to enable access to a disk that was disabled with the "Disable (offline) a disk device" operation.

You can also use this operation to re-scan a disk that may have been changed outside of the Volume Manager. For example, if a disk is shared between two systems, the Volume Manager running on the other system may have changed the disk. If so, you can use this operation to re-scan the disk.

NOTE: Many `vxdiskadm` operations re-scan disks without user intervention. This will eliminate the need to online a disk directly, except when the disk is directly offlined.

```
Select a disk device to enable [<address>,list,q,?] c1t1d0
vxdiskadm enables the specified device.
```

3. At the following prompt, indicate whether you want to enable another device (**y**) or return to the `vxdiskadm` main menu (**n**):

Enable another device? [y,n,q,?] (default: n)

You can also issue the command `vxdctl enable` after a hot disk swap. This enables VxVM to recognize the new disk and any paths to it that are available through Dynamic Multipathing (DMP).

## Taking a Disk Offline

There are instances when you must take a disk offline. If a disk is corrupted, you must disable the disk before removing it. You must also disable a disk before moving the physical disk device to another location to be connected to another system.

---

**Note** Taking a disk offline is only useful on systems that support *hot-swap* removal and insertion of disks without needing to shut down and reboot the system.

---

To take a physical disk offline, first remove the disk from its disk group (see “[Renaming a Disk](#)” on page 68), and then place the disk in an “offline” state with the following command:

```
# vxdisk offline devicename
```

For example, to take the device `c1t1d0s2` off line, use the following command:

```
# vxdisk offline c1t1d0s2
```

---

**Note** The device name is used here because the disk is no longer in a disk group, so it does not have an administrative name.

---

Alternatively, you can use the `vxdiskadm` command to take a disk offline:

1. Select menu item 11 (Disable (offline) a disk device) from the `vxdiskadm` main menu.
2. At the following prompt, enter the address of the disk you want to disable:

```
Disable (offline) a disk device
Menu: VolumeManager/Disk/OfflineDisk
```

Use this menu operation to disable all access to a disk device by the Volume Manager. This operation can be applied only to disks that are not currently in a disk group. Use this operation if you intend to remove a disk from a system without rebooting.

NOTE: Many systems do not support disks that can be removed from a system during normal operation. On such systems, the offline operation is seldom useful.

```
Select a disk device to disable [<address>,list,q,?] c1t1d0
```

The `vxdiskadm` program disables the specified disk.



3. At the following prompt, indicate whether you want to disable another device (**y**) or return to the `vxdiskadm` main menu (**n**):

```
Disable another device? [y,n,q,?] (default: n)
```

## Renaming a Disk

If you do not specify a VM disk name, VxVM gives the disk a default name when you add the disk to VxVM control. The VM disk name is used by VxVM to identify the location of the disk or the disk type. To change the disk name to reflect a change of use or ownership, use the following command:

```
# vxedit rename old_diskname new_diskname
```

To rename `disk01` to `disk03`, use the following command:

```
# vxedit rename disk01 disk03
```

To confirm that the name change took place, use the following command:

```
# vxdisk list
```

VxVM returns the following display:

DEVICE	TYPE	DISK	GROUP	STATUS
c0t0d0s2	sliced	disk04	rootdg	online
c1t0d0s2	sliced	disk03	rootdg	online
c1t1d0s2	sliced	-	-	online

---

**Note** By default, VxVM names subdisk objects after the VM disk on which they are located. Renaming a VM disk does not automatically rename the subdisks on that disk.

---

## Reserving Disks

By default, the `vxassist` command allocates space from any disk that has free space. You can reserve a set of disks for special purposes, such as to avoid general use of a particularly slow or a particularly fast disk.

To reserve a disk for special purposes, use the following command:

```
# vxedit set reserve=on diskname
```

After you enter this command, the `vxassist` program does not allocate space from the selected disk unless that disk is specifically mentioned on the `vxassist` command line. For example, if `disk03` is reserved, use the following command:

```
# vxassist make vol03 20m disk03
```

The `vxassist` command overrides the reservation and creates a 20 megabyte volume on `disk03`. However, the command:

```
# vxassist make vol04 20m
```

does not use `disk03`, even if there is no free space on any other disk.

To turn off reservation of a disk, use the following command:

```
# vxedit set reserve=off diskname
```

See Special Attribute Values for Disk Media in `vxedit(1M)` for more information.

## Displaying Disk Information

Before you use a disk, you need to know if it has been initialized and placed under VxVM control. You also need to know if the disk is part of a disk group, because you cannot create volumes on a disk that is not part of a disk group. The `vxdisk list` command displays device names for all recognized disks, the disk names, the disk group names associated with each disk, and the status of each disk.

To display information on all disks that are defined to VxVM, use the following command:

```
# vxdisk list
```

VxVM returns a display similar to the following:

DEVICE	TYPE	DISK	GROUP	STATUS
c0t0d0s2	sliced	disk04	rootdg	online
c1t0d0s2	sliced	disk03	rootdg	online
c1t1d0s2	sliced	-	-	error

---

**Note** The phrase `error` in the `STATUS` line indicates that a disk has not yet been added to VxVM control. These disks may or may not have been initialized by VxVM previously. Disks that are listed as `online` are already under VxVM control.

---

To display details on a particular disk defined to VxVM, use the following command:

```
# vxdisk list diskname
```

## Displaying Multipaths to a VM Disk

The `vxdisk` command is used to display the multipathing information for a particular metadvice. The metadvice is a device representation of a particular physical disk having multiple physical paths from the I/O controller of the system. In VxVM, all the physical disks in the system are represented as metadevices with one or more physical paths.



To view multipathing information for a particular metadvice, use the following command:

```
# vxdisk list devicename
```

For example, to view multipathing information for `c2t0d0s2`, use the following command:

```
# vxdisk list c2t0d0s2
```

Typical output is as follows:

```
Device      c2t0d0
devicetag   c2t0d0
type        sliced
hostid      aparajita
disk        name=disk01 id=861086917.1052.aparajita
group       name=rootdg id=861086912.1025.aparajita
flags       online ready autoconfig autoimport imported
pubpaths    block=/dev/vx/dmp/c2t0d0s4 char=/dev/vx/rdmp/c2t0d0s4
privpaths   block=/dev/vx/dmp/c2t0d0s3 char=/dev/vx/rdmp/c2t0d0s3
version     2.1
iosize      min=512 (bytes) max=2048 (blocks)
public      slice=4 offset=0 len=1043840
private     slice=3 offset=1 len=1119
update      time=861801175 seqno=0.48
headers     0 248
configs     count=1 len=795
logs        count=1 len=120
Defined regions
config      priv 000017-000247[000231]:copy=01 offset=000000
enabled
config      priv 000249-000812[000564]:copy=01 offset=000231
enabled
log         priv 000813-000932[000120]:copy=01 offset=000000
enabled
Multipathing information:
numpaths:   2
c2t0d0s2    state=enabled      type=primary
c1t0d0s2    state=disabled     type=secondary
```

In the Multipathing information section of this output, the `numpaths` line shows that there are 2 paths to the device, and the following two lines show that the path to `c2t0d0s2` is active (`state=enabled`) and that the other path `c1t0d0s2` has failed (`state=disabled`).

The `type` field is shown for disks on active/passive type disk arrays such as DG Clarion, and Hitachi DF350. This field indicates the *primary* and *secondary* paths to the disk.



The `type` field is not displayed for disks on active/active type disk arrays such as StorEdge A5000 and Sparc Storage Array (SSA). Such arrays have no concept of primary and secondary paths.

## Displaying Disk Information with `vxdiskadm`

Displaying disk information shows you which disks are initialized, to which disk groups they belong, and the disk status. The `list` command displays device names for all recognized disks, the disk names, the disk group names associated with each disk, and the status of each disk.

To display disk information, use the following procedure:

1. Start the `vxdiskadm` program, and select `list` (List disk information) from the main menu.
2. At the following display, enter the address of the disk you want to see, or enter `all` for a list of all disks:

```
List disk information
Menu: VolumeManager/Disk/ListDisk
```

Use this menu operation to display a list of disks. You can also choose to list detailed information about the disk at a specific disk device address.

```
Enter disk device or "all" [<address>,all,q,?] (default: all)
```

- If you enter `all`, VxVM displays the device name, disk name, group, and status.
- If you enter the address of the device for which you want information, complete disk information (including the device name, the type of disk, and information about the public and private areas of the disk) is displayed.

Once you have examined this information, press Return to return to the main menu.

## Prevent Multipathing/Suppress Devices from VxVM's View

Use this menu task to suppress a device from VxVM's view or prevent a device from being multipathed by `vxdmp`. The following steps are involved in the process:

---

**Note** Some of the operations described in this section will require a reboot of the system to become effective. Need for reboot is indicated wherever required.

---



1. **Select menu item 17 (Prevent multipathing/Suppress devices from VxVM's view) from the vxdiskadm main menu.**

2. **At the following prompt enter the action to be taken:**

```
Exclude Devices
Menu: VolumeManager/Disk/ExcludeDevices
```

This operation might lead to some devices being suppressed from VxVM's view or prevent them from being multipathed by vxdkmp (This operation can be reversed using the vxdiskadm command).

```
Do you want to continue ? [y,n,q,?] (default: y)
```

3. **If you say y at the previous step, the following set of operations will be listed. Select the operation you want to perform.**

```
Exclude Devices
Menu: VolumeManager/Disk/ExcludeDevices
```

```
1 Suppress all paths through a controller from VxVM's view
2 Suppress a path from VxVM's view
3 Suppress disks from VxVM's view by specifying a VID:PID
  combination
4 Suppress all but one paths to a disk
5 Prevent multipathing of all disks on a controller by VxVM
6 Prevent multipathing of a disk by VxVM
7 Prevent multipathing of disks by specifying a VID:PID combination
8 List currently suppressed/non-multipathed devices
```

```
? Display help about menu
??Display help about the menuing system
q Exit from menus
```

Select an operation to perform:

4. **If you select option 1 from the above screen, enter the controller name at the following prompt:**

```
Exclude controllers from VxVM
Menu: VolumeManager/Disk/ExcludeDevices/CTLR-VXVM
```

Use this operation to exclude all paths through a controller from VxVM.

This operation can be reversed using the vxdiskadm command.

You can specify a controller name at the prompt. A controller name is of the form c#, example c3, c11 etc. Enter 'all' to exclude all paths on all the controllers on the host. To see the list of controllers on the system, type 'list'.

Enter a controller name:[ctrl\_name,all,list,list-exclude,q,?]

The controller specified will have all paths through it suppressed from VxVM's view. These paths will show up in the disabled state until the next reboot.

**5. If you choose option 2 from the first screen, the following prompt will be displayed:**

Exclude paths from VxVM  
Menu: VolumeManager/Disk/ExcludeDevices/PATH-VXVM

Use this operation to exclude one or more paths from VxVM.

As a result of this operation, the specified paths will be excluded from the view of VxVM. This operation can be reversed using the vxdiskadm command.

You can specify a pathname or a pattern at the prompt. Here are some path selection examples:

all: all paths  
c4t2:all paths on controller 4, target 2  
c3t4d2:a single path  
list:list all paths on the system

Enter a pathname or pattern:[<Pattern>,all,list,list-exclude,q?]

The path specified here will be excluded from VxVM control.

**6. If option 3 is selected from the first screen, you are required to enter the VID:PID combination of the device to be excluded from VxVM. This requires a system reboot for device exclusion to take effect.**

Exclude VID:PID from VxVM  
Menu: VolumeManager/Disk/ExcludeDevices/VIDPID-VXVM

Use this operation to exclude disks returning a specified VendorID:ProductID combination from VxVM.

As a result of this operation, all disks that return VendorID:ProductID matching the specified combination will be excluded from the view of VxVM. This operation can be reversed using the vxdiskadm command.



You can specify a VendorID:ProductID pattern at the prompt. The specification can be as follows :

VID:PID                where VID stands for Vendor ID

PID stands for Product ID

(The command `vxdmpinq` in `/etc/vx/diag.d` can be used to obtain the Vendor ID and Product ID)

Both VID and PID can have an optional '\*' (asterisk) following them.

If a '\*' follows VID, it will result in the exclusion of all disks returning Vendor ID starting with the specified VID. The same is true for Product ID as well. Both VID and PID should be non NULL. The maximum allowed lengths for VendorID and ProductID are 8 and 16 characters respectively.

Some examples of VID:PID specification are:

```
all- Exclude all disks
aaa:123- Exclude all disks having VID 'aaa' and PID '123'
aaa*:123- Exclude all disks having VID starting with 'aaa' and
          PID '123'
aaa:123*- Exclude all disks having VID 'aaa' and PID starting
          with '123'
aaa:*- Exclude all disks having VID 'aaa' and any PID
```

Enter a VID:PID combination:[<Pattern>,all,list-exclude,q,?]

The disks that match the VID:PID combination will be excluded from VxVM.

- 7. Option 4 defines a pathgroup in case of disks which are not multipathed by VxVM. Only one path is made visible from the group. Specify the paths to be included in the pathgroup.**

Exclude all but one paths to a disk  
Menu: VolumeManager/Disk/ExcludeDevices/PATHGROUP-VXVM

Use this operation to exclude all but one paths to a disk. In case of disks which are not multipathed by `vxdmp`, VxVM will see each path as a disk. In such cases, creating a pathgroup of all paths to the disk will ensure that only one of the paths from the group is made visible to VxVM. The pathgroup can be removed using the `vxdiskadm` command.

Example: If c1t30d0 and c2t30d0 are paths to the same disk and both are seen by VxVM as separate disks, c1t30d0 and c2t30d0 can be put in a pathgroup so that only one of these paths is visible to VxVM.

The pathgroup can be specified as a list of blank separated paths, for example, c1t30d0 c2t30d0.

Enter pathgroup: [<pattern>,list,list-exclude,q,?]

8. The next three options allow you to exclude devices from being multipathed by vxdmp. If option 5 is selected the following screen is displayed:

Exclude controllers from DMP

Menu: VolumeManager/Disk/ExcludeDevices/CTLR-DMP

Use this operation to exclude all disks on a controller from being multipathed by vxdmp.

As a result of this operation, all disks having a path through the specified controller will be claimed in the OTHER\_DISKS category and hence, not multipathed by vxdmp. This operation can be reversed using the vxdiskadm command.

You can specify a controller name at the prompt. A controller name is of the form c#, example c3, c11 etc. Enter 'all' to exclude all paths on all the controllers on the host. To see the list of controllers on the system, type 'list'.

Enter a controller name:[<ctlr-name>,all,list,list-exclude,q,?]

The controller mentioned here is excluded from vxdmp control.

9. Option 6 excludes the specified path from vxdmp. Enter the path name at the prompt after the screen:

Exclude paths from DMP

Menu: VolumeManager/Disk/ExcludeDevices/PATH-DMP

Use this operation to exclude one or more disks from DMP.

As a result of this operation, the disks corresponding to the specified paths will not be multipathed by DMP. This operation can be reversed using the vxdiskadm command.

You can specify a pathname or a pattern at the prompt. Here are some path selection examples:

all:all paths



```
c4t2:all paths on controller 4, target 2
c3t4d2:a single path
list:list all paths on the system
```

Enter a pathname or pattern : [<pattern>,all,list,list-exclude,q,?]

If a path is specified, the corresponding disk will be claimed in the OTHER\_DISKS category and hence not multipathed.

- 10. Selecting option 7 excludes the disk corresponding the specified VIP:PID combination. This operation requires a system reboot for the device exclusion to take effect.**

```
Exclude VID:PID from DMP
Menu: VolumeManager/Disk/ExcludeDevices/VIDPID-DMP
```

Use this operation to prevent vxdmp from multipathing disks returning a specific VID:PID combination.

As a result of this operation, all disks that return VendorID:ProductID matching the specified combination will be claimed in the OTHER DISKS category(i.e. they will not be multipathed by vxdmp). This operation can be reversed using the vxdiskadm command.

You can specify a VendorID:ProductID combination at the prompt. The specification can be as follows :

```
VID:PID          where VID stands for Vendor ID PID stands for
Product ID
(The command vxdumping in /etc/vx/diag.d can be used to obtain the
Vendor ID and Product ID)
Both VID and PID can have an optional '*' (asterisk) following
them.
If a '*' follows VID, it will result in the exclusion of all disks
returning Vendor ID starting with the specified VID. The same is
true for Product ID as well. Both VID and PID should be non NULL.
The maximum allowed lengths for Vendor ID and Product ID are 8 and
16 characters respectively.
```

Some examples of VID:PID specification are:

```
all- Exclude all disks
aaa:123- Exclude all disks having VID 'aaa' and PID '123'
aaa*:123- Exclude all disks having VID starting with 'aaa' and
        PID '123'
```

```
aaa:123*- Exclude all disks having VID 'aaa' and PID starting
           with '123'
aaa:*- Exclude all disks having VID 'aaa' and any PID
```

Enter a VID:PID combination: [<pattern>,all,list,list-exclude,q,?]

All disks returning the specified VID:PID combination will be claimed in OTHER\_DISKS category and hence not multipathed.

## Allow Multipathing/Unsuppress Devices from VxVM's View

The devices selected in this operation will be visible to VxVM and/or will be multipathed by vxdmp again.

---

**Note** Some of the operations described in this section will require a reboot of the system to become effective. Need for reboot is indicated wherever required.

---

1. Select menu task 18 from the vxdiskadm menu options. The following screen is displayed:

```
Include Devices
Menu: VolumeManager/Disk/IncludeDevices
```

```
The devices selected in this operation will become visible to
VxVM and/or will be multipathed by vxdmp again. Only those
devices which were previously excluded can be included again.
Do you want to continue ? [y,n,q,?] (default: y)
```

2. If you choose to continue, the following screen is displayed. Select the option you want to use:

```
Volume Manager Device Operations
Menu: VolumeManager/Disk/IncludeDevices
```

```
1 Unsuppress all paths through a controller from VxVM's view
2 Unsuppress a path from VxVM's view
3 Unsuppress disks from VxVM's view by specifying a VID:PID
  combination
4 Remove a pathgroup definition
5 Allow multipathing of all disks on a controller by VxVM
6 Allow multipathing of a disk by VxVM
7 Allow multipathing of disks by specifying a VID:PID combination
8 List currently suppressed/non-multipathed devices

? Display help about menu
??Display help about the menuing system
```



q Exit from menus

Select an operation to perform:

- 3. If you want to re-include a controller in VxVM select option 1. Enter the name of the controller you want to re-include.**

Re-include controllers in VxVM

Menu: VolumeManager/Disk/IncludeDevices/CTLR-VXVM

Use this operation to make all paths through a controller visible to VxVM again.

As a result of this operation, all paths through the specified controller will be made visible to VxVM again.

You can specify a controller name at the prompt. A controller name is of the form c#, example c3, c11 etc. Enter 'all' to include all paths on all controllers on the host.

Enter a controller name:[<ctlr-name>,all,list,list-exclude,q,?]

- 4. To make a specific path visible to VxVM choose option 2. Enter the name of the path at the prompt following the screen:**

Re-include paths in VxVM

Menu: VolumeManager/Disk/IncludeDevices/PATH-VXVM

Use this operation to make one or more paths visible to VxVM again.

As a result of this operation, the specified paths will become visible to VxVM again.

You can specify a pathname or a pattern at the prompt. Here are some path selection examples:

all:	all paths
c4t2:	all paths on controller 4, target 2
c3t4d2:	a single path

Enter a pathname or pattern : [<pattern>,all,list,list-exclude,q,?]

- 5. Select option 3 to re-include the disks that were excluded using a VID:PID combination. This option requires a system reboot for the device inclusion to take effect.**

Make VID:PID visible to VxVM

Menu: VolumeManager/Disk/IncludeDevices/VIDPID-VXVM





Use this operation to make all disks returning a specified VendorID:ProductID combination visible to VxVM again.

As a result of this operation, disks that return VendorID:ProductID matching the specified combination will be made visible to VxVM again.

You can specify a VID:PID combination at the prompt. The specification can be as follows :

VID:PID                where VID stands for Vendor ID PID stands for Product ID

(The command vxddmping in /etc/vx/diag.d can be used to obtain the Vendor ID and Product ID)

Both VID and PID can have an optional '\*' (asterisk) following them.

If a '\*' follows VID, it will result in the inclusion of all disks returning Vendor ID starting with VID. The same is true for Product ID as well. Both VID and PID should be non NULL. The maximum allowed lengths for Vendor ID and Product ID are 8 and 16 characters respectively.

Some examples of VID:PID specification are:

```
all- Include all disks
aaa:123- Include all disks having VID 'aaa' and PID '123'
aaa*:123- Include all disks having VID starting with 'aaa' and
          PID '123'
aaa:123*- Include all disks having VID 'aaa' and PID starting
          with '123'
aaa:*- Include all disks having VID 'aaa' and any PID
```

Enter a VID:PID combination:[<pattern>,all,list,list-exclude,q,?]

All disks returning the specified Vendor ID and Product ID combination will be made visible to VxVM.

6. Option 4 removes pathgroups that have been defined earlier. Once a pathgroup is removed, all paths in that group become visible.

Remove a pathgroup definition  
Menu: VolumeManager/Disk/IncludeDevices/PATHGROUP-VXVM

Use this operation to remove the definition of pathgroup. Specify the serial numbers of the pathgroups at the prompt. This can be obtained by typing list-exclude at the prompt.



Enter pathgroup number(s):[<number>,list-exclude,q,?]

- 7. Option 5 re-includes devices with the specified controller name in DMP. Enter the controller name at the prompt in the screen that follows. This option requires a system reboot for the device inclusion to take effect.**

Re-include controllers in DMP

Menu: VolumeManager/Disk/IncludeDevices/CTLR-DMP

Use this operation to make vxdkmp multipath all disks on a controller again.

As a result of this operation, all disks having a path through the specified controller will be multipathed by vxdkmp again.

You can specify a controller name at the prompt. A controller name is of the form c#, example c3, c11 etc. Enter 'all' to include all paths on all controllers on the host.

Enter a controller name:[<ctrlr-name>,all,list,list-exclude,q,?]

All disks having paths through the specified controller will be multipathed by vxdkmp again.

- 8. Option 6 re-includes paths under DMP. Enter the name of the path to be included at the prompt that follows in the screen. This option requires a system reboot for the device inclusion to take effect.**

Re-include paths in DMP

Menu: VolumeManager/Disk/IncludeDevices/PATH-DMP

Use this operation to make vxdkmp multipath one or more disks again.

As a result of this operation, all disks corresponding to the specified paths will be multipathed by vxdkmp again.

You can specify a pathname or a pattern at the prompt. Here are some path selection examples:

all:	all paths
c4t2:	all paths on controller 4, target 2
c3t4d2:	a single path

Enter a pathname or pattern :[<pattern>,all,list,list-exclude,q,?]

DMP multipaths the disks corresponding to the specified path.



- 9. Selecting option 7 re-includes the disks which return the VendorID:ProductID combination. This option requires a system reboot for the device inclusion to take effect.**

```
Make VID:PID visible to DMP
Menu: VolumeManager/Disk/IncludeDevices/VIDPID-DMP
```

Use this operation to make vxddmp multipath disks returning a specified VendorID:ProductID combination again.

As a result of this operation, all disks that return VID:PID matching the specified combination will be multipathed by vxddmp again.

You can specify a VID:PID combination at the prompt. The specification can be as follows :

```
VID:PID          where VID stands for Vendor ID PID stands for
Product ID
```

(The command vxddmpinq in /etc/vx/diag.d can be used to obtain the Vendor ID and Product ID)

Both VID and PID can have an optional '\*' (asterisk) following them.

If a '\*' follows VID, it will result in the inclusion of all disks returning Vendor ID starting with the specified VID. The same is true for Product ID as well. Both VID and PID should be non NULL. The maximum allowed lengths for Vendor ID and Product ID are 8 and 16 characters respectively.

Some examples of VID:PID specification are:

```
all- Include all disks
aaa:123- Include all disks having VID 'aaa' and PID '123'
aaa*:123- Include all disks having VID starting with 'aaa' and
        PID '123'
aaa:123*- Include all disks having VID 'aaa' and PID starting
        with '123'
aaa:*- Include all disks having VID 'aaa' and any PID
```

Enter a VID:PID combination:[<pattern>,all,list-exclude,q,?]

**All disks returning the specified Vendor ID and Product ID combination will be multipathed by vxddmp again.**





## Introduction

This chapter describes how to create and manage *disk groups*. Disk groups are named collections of disks that share a common configuration. Volumes are created within a disk group and are restricted to using disks within that disk group.

---

**Note** Most VERITAS Volume Manager (VxVM) commands require superuser or equivalent privileges.

---

A system with VxVM installed has a default disk group configured, `rootdg`. By default, operations are directed to the `rootdg` disk group. As system administrator, you can create additional disk groups to arrange your system's disks for different purposes. Many systems do not use more than one disk group, unless they have a large number of disks. Disks are not added to disk groups until the disks are needed to create VxVM objects. Disks can be initialized, reserved, and added to disk groups later. However, at least one disk must be added to `rootdg` when you initially configure VxVM after installation.

When a disk is added to a disk group, it is given a name (for example, `disk02`). This name identifies a disk for volume operations: volume creation or mirroring. This name relates directly to the physical disk. If a physical disk is moved to a different target address or to a different controller, the name `disk02` continues to refer to it. Disks can be replaced by first associating a different physical disk with the name of the disk to be replaced and then recovering any volume data that was stored on the original disk (from mirrors or backup copies).

Having large disk groups can cause the private region to fill. In the case of larger disk groups, disks should be set up with larger private areas to log in. A major portion of a private region is space for a disk group configuration database containing records for each VxVM object in that disk group. Because each configuration record takes up 256 bytes (or half a block), the number of records that can be created in a disk group is twice the configuration database copy size. The copy size can be obtained from the output of the command `vxdg list diskgroup` as the value of the `len` field on lines starting with `config`. See [“Displaying Disk Group Information”](#) on page 95 for an example.



**Caution** Before making any changes to disk groups, use the commands `vxprint -hrm` and `vxdisk list` to record the current configuration.

---

## Specifying a Disk Group to Commands

Most VxVM commands allow you to specify a disk group using the `-g` option. For example, to create a volume in disk group `mkt dg`, use the following command:

```
# vxassist -g mkt dg make mkt vol 50m
```

The block special device for this volume is:

```
/dev/vx/dsk/mkt dg/mkt vol
```

The disk group does not have to be specified if the object names are unique. Most VxVM commands use object names specified on the command line to determine the disk group for the operation. For example, to create a volume on disk `mkt dg01` without specifying the disk group name, use the following command:

```
# vxassist make mkt vol 50m mkt dg01
```

Many commands work this way as long as two disk groups do not have objects with the same name. For example, VxVM allows you to create volumes named `mkt vol` in both `root dg` and in `mkt dg`. If you do this, you must add `-g mkt dg` to any command where you want to manipulate the volume in the `mkt dg` disk group.

## Creating a Disk Group

Data related to a particular set of applications or a particular group of users may need to be made accessible on another system. Examples of this are:

- ◆ A system has failed and its data needs to be moved to other systems.
- ◆ The work load must be balanced across a number of systems.

It is important that the data related to particular applications or users be located on an identifiable set of disks, so that when these disks are moved, all data of the applications or group of users, and no other data, is moved.

Disks must be placed in disk groups before VxVM can use the disks for volumes. VxVM always requires the root disk group to be defined, but you can add more disk groups as required.

---

**Note** VxVM commands create all volumes in the default disk group, `rootdg`, if no alternative disk group is specified using the `-g` option (see “[Specifying a Disk Group to Commands](#)” on page 84). All commands default to the `rootdg` disk group unless the disk group can be deduced from other information such as a disk name.

---

A disk group must have at least one disk associated with it. A new disk group can be created when you use menu item 1 (Add or initialize one or more disks) of the `vxdiskadm` command to add disks to VxVM control, as described in “[Adding a Disk to VxVM](#)” on page 46. Disks to be added to a disk group must not already belong to an existing disk group.

You can also use the `vxdiskadd` command to create a new disk group, for example:

```
# vxdiskadd c1t1d0
```

where `c1t1d0` is the device name of a disk that is not currently assigned to a disk group.

Disk groups can also be created by using the command `vx dg init`:

```
# vx dg init diskgroup diskname=devicename
```

For example, to create a disk group named `mktdg` on device `c1t0d0s2`:

```
# vx dg init mktdg mktdg01=c1t0d0
```

The disk specified by the device name, `c1t0d0`, must have been previously initialized with `vxdiskadd` or `vxdiskadm`, and must not currently belong to a disk group.

## Adding a Disk to a Disk Group

To add a disk to an existing disk group, use menu item 1 (Add or initialize one or more disks) of the `vxdiskadm` command, as described in “[Adding a Disk to VxVM](#)” on page 46.

You can also use the `vxdiskadd` command to add a disk to a disk group, for example:

```
# vxdiskadd c1t2d0
```

where `c1t2d0` is the device name of a disk that is not currently assigned to a disk group.



## Removing a Disk from a Disk Group

A disk that contains no subdisks can be removed from its disk group with this command:

```
# vxdg [-g groupname] rmdisk diskname
```

where the disk group name is only specified for a disk group other than the default, rootdg.

For example, to remove disk02 from rootdg, use this command:

```
# vxdg rmdisk disk02
```

If the disk has subdisks on it when you try to remove it, the following error message is displayed:

```
vxdg:Disk diskname is used by one or more subdisks
```

Use the `-k` option to `vxdg` to remove device assignment. Using the `-k` option allows you to remove the disk even if subdisks are present. For more information, see the `vxdg(1M)` manual page.

---

**Note** Use of the `-k` option to `vxdg` can result in data loss.

---

Once the disk has been removed from its disk group, you can (optionally) remove it from VxVM control completely, as follows:

```
# vxdisk rm devicename
```

For example, to remove c1t0d0 from VxVM control, use these commands:

```
# vxdisk rm c1t0d0s2
```

You can remove a disk on which some subdisks are defined. For example, you can consolidate all the volumes onto one disk. If you use `vxdiskadm` to remove a disk, you can choose to move volumes off that disk. To do this, run `vxdiskadm` and select item 3 (Remove a disk) from the main menu.

If the disk is used by some subdisks, then this typical message is displayed:

```
The following subdisks currently use part of disk disk02:
```

```
home usrvol
```

```
Subdisks must be moved from disk02 before it can be removed.
```

```
Move subdisks to other disks? [y,n,q,?] (default: n)
```

If you choose `y`, then all subdisks are moved off the disk, if possible. Some subdisks may not be movable. The most common reasons why a subdisk may not be movable are as follows:



- ◆ There is not enough space on the remaining disks.
- ◆ Plexes or striped subdisks cannot be allocated on different disks from existing plexes or striped subdisks in the volume.

If `vxdiskadm` cannot move some subdisks, you may need to remove some plexes from some disks to free more space before proceeding with the disk removal operation.

## Deporting a Disk Group

Deporting a disk group disables access to a disk group that is currently enabled (imported) by the system. Deport a disk group if you intend to move the disks in a disk group to another system. Also, deport a disk group if you want to use all of the disks remaining in a disk group for a new purpose.

To deport a disk group, use the following procedure:

1. Stop all activity by applications to volumes that are configured in the disk group that is to be deported. Unmount file systems and shut down databases that are configured on the volumes.
2. Use the following command to stop the volumes in the disk group:
 

```
# vxvol -g diskgroup stopall
```
3. Select menu item 9 (Remove access to (deport) a disk group) from the `vxdiskadm` main menu.
4. At the following prompt, enter the name of the disk group to be deported (in this example, `newdg`):

```
Remove access to (deport) a disk group
Menu: VolumeManager/Disk/DeportDiskGroup
```

Use this menu operation to remove access to a disk group that is currently enabled (imported) by this system. Deport a disk group if you intend to move the disks in a disk group to another system. Also, deport a disk group if you want to use all of the disks remaining in a disk group for some new purpose.

```
You will be prompted for the name of a disk group. You will also
be asked if the disks should be disabled (offlined). For
removable disk devices on some systems, it is important to
disable all access to the disk before removing the disk.
Enter name of disk group [<group>,list,q,?] (default: list)
newdg
```



5. At the following prompt, enter `y` if you intend to remove the disks in this disk group:

```
The requested operation is to disable access to the removable
disk group named newdg. This disk group is stored on the
following disks:
```

```
newdg01 on device c1t1d0
```

```
You can choose to disable access to (also known as "offline")
these disks. This may be necessary to prevent errors if
you actually remove any of the disks from the system.
```

```
Disable (offline) the indicated disks? [y,n,q,?] (default: n) y
```

6. At the following prompt, press Return to continue with the operation:

```
Continue with operation? [y,n,q,?] (default: y)
```

Once the disk group is deported, the `vxdiskadm` utility displays the following message:

```
Removal of disk group newdg was successful.
```

7. At the following prompt, indicate whether you want to disable another disk group (`y`) or return to the `vxdiskadm` main menu (`n`):

```
Disable another disk group? [y,n,q,?] (default: n)
```

Alternatively, you can use the `vxchg` command to deport a disk group:

```
# vxchg deport diskgroup
```

## Importing a Disk Group

Importing a disk group enables access by the system to a disk group. To move a disk group from one system to another, first disable (deport) the disk group on the original system, and then move the disk between systems and enable (import) the disk group.

To import a disk group, use the following procedure:

1. Use the following command to ensure that the disks in the deported disk group are online:

```
# vxdisk -g diskgroup list
```

2. Select menu item 8 (Enable access to (import) a disk group) from the `vxdiskadm` main menu.

3. At the following prompt, enter the name of the disk group to import (in this example, newdg):

```
Enable access to (import) a disk group
Menu: VolumeManager/Disk/EnableDiskGroup
```

Use this operation to enable access to a disk group. This can be used as the final part of moving a disk group from one system to another. The first part of moving a disk group is to use the "Remove access to (deport) a disk group" operation on the original host.

A disk group can be imported from another host that failed without first deporting the disk group. Be sure that all disks in the disk group are moved between hosts.

If two hosts share a SCSI bus, be very careful to ensure that the other host really has failed or has deported the disk group. If two active hosts import a disk group at the same time, the disk group will be corrupted and will become unusable.

```
Select disk group to import [<group>,list,q,?] (default: list)
newdg
```

Once the import is complete, the `vxdiskadm` utility displays the following success message:

```
The import of newdg was successful.
```

4. At the following prompt, indicate whether you want to import another disk group (y) or return to the `vxdiskadm` main menu (n):

```
Select another disk group? [y,n,q,?] (default: n)
```

Alternatively, you can use the `vx dg` command to import a disk group:

```
# vx dg import diskgroup
```



## Renaming a Disk Group

Only one disk group of a given name can exist per system. It is not possible to import or deport a disk group when the target system already has a disk group of the same name. To avoid this problem, VxVM allows you to rename a disk group during import or deport.

For example, because every system running VxVM must have a single `rootdg` default disk group, importing or deporting `rootdg` across systems is a problem. There cannot be two `rootdg` disk groups on the same system. This problem can be avoided by renaming the `rootdg` disk group during the import or deport.

To rename a disk group during import, use the following command:

```
# vxdg [-t] -n newdg import diskgroup
```

If the `-t` option is included, the import is temporary and does not persist across reboots. In this case, the stored name of the disk group remains unchanged on its original host, but the disk group is known as `newdg` to the importing host. If the `-t` option is not used, the name change is permanent.

To rename a disk group during deport, use the following command:

```
# vxdg [-h hostname] -n newdg deport diskgroup
```

When renaming on deport, you can specify the `-h hostname` option to assign a lock to an alternate host. This ensures that the disk group is automatically imported when the alternate host reboots.

To temporarily move the `rootdg` disk group from one host to another (for repair work on the root volume, for example) and then move it back, use the following procedure:

1. On the original host, identify the disk group ID of the root disk group to be imported with the following command:

```
# vxdisk -s list
```

This command results in output such as the following:

```
dgname: rootdg
dgid: 774226267.1025.tweety
```

2. On the importing host, import and rename the `rootdg` disk group with this command:

```
# vxdg -tC -n newdg import diskgroup
```

where `-t` indicates a temporary import name; `C` clears import locks; `-n` specifies a temporary name for the `rootdg` to be imported (so it does not conflict with the existing `rootdg`); and `diskgroup` is the disk group ID of the disk group being imported (for example, `774226267.1025.tweety`).

If a reboot or crash occurs at this point, the temporarily imported disk group becomes unimported and requires a reimport.

3. After the necessary work has been done on the imported `rootdg`, deport it back to its original host with this command:

```
# vxdg -h hostname deport diskgroup
```

where `hostname` is the name of the system whose `rootdg` is being returned (the system name can be confirmed with the command `uname -n`).

This command removes the imported `rootdg` from the importing host and returns locks to its original host. The original host then automatically imports its `rootdg` on the next reboot.

## Moving Disks between Disk Groups

To move a disk between disk groups, remove the disk from one disk group and add it to the other. For example, to move the physical disk `c0t3d0` (attached with the disk name `disk04`) from disk group `rootdg` and add it to disk group `mkt dg`, use the following commands:

```
# vxdg rmdisk disk04
# vxdg -g mkt dg adddisk mkt dg02=c0t3d0
```

---

**Note** This procedure does not save the configurations or data on the disks.

---

You can also move a disk by using the `vxdiskadm` command. Select item 3 (Remove a disk) from the main menu, and then select item 1 (Add or initialize a disk).



## Moving Disk Groups Between Systems

An important feature of disk groups is that they can be moved between systems. If all disks in a disk group are moved from one system to another, then the disk group can be used by the second system. You do not have to re-specify the configuration.

To move a disk group between systems, use the following procedure:

1. On the first system, stop all volumes in the disk group, then deport (disable local access to) the disk group with the following command:

```
# vxdg deport diskgroup
```

2. Move all the disks to the second system and perform the steps necessary (system-dependent) for the second system and VxVM to recognize the new disks.

This can require a reboot, in which case the `vxconfigd` daemon is restarted and recognizes the new disks. If you do not reboot, use the command `vxctl enable` to restart the `vxconfigd` program so VxVM also recognizes the disks.

3. Import (enable local access to) the disk group on the second system with this command:

```
# vxdg import diskgroup
```

---

**Caution** All disks in the disk group must be moved to the other system. If they are not moved, the import will fail.

---

4. After the disk group is imported, start all volumes in the disk group with this command:

```
# vxrecover -g diskgroup -sb
```

You can also move disks from a system that has crashed. In this case, you cannot deport the disk group from the first system. When a disk group is created or imported on a system, that system writes a lock on all disks in the disk group.

---

**Caution** The purpose of the lock is to ensure that *dual-ported disks* (disks that can be accessed simultaneously by two systems) are not used by both systems at the same time. If two systems try to manage the same disks at the same time, configuration information stored on the disk is corrupted. The disk and its data become unusable.

---

When you move disks from a system that has crashed or failed to detect the group before the disk is moved, the locks stored on the disks remain and must be cleared. The system returns the following error message:

```
vx dg:disk group groupname: import failed: Disk is in use by
another
host
```

To clear locks on a specific set of devices, use the following command:

```
# vx disk clearimport devicename ...
```

To clear the locks during import, use the following command:

```
# vx dg -C import diskgroup
```

---

**Caution** Be careful when using the `vx disk clearimport` or `vx dg -C import` command on systems that have dual-ported disks. Clearing the locks allows those disks to be accessed at the same time from multiple hosts and can result in corrupted data.

---

You may want to import a disk group when some disks are not available. The `import` operation fails if some disks for the disk group cannot be found among the disk drives attached to the system. When the `import` operation fails, one of several error messages is displayed.

The following message indicates a fatal error that requires hardware repair or the creation of a new disk group, and recovery of the disk group configuration and data.

```
vx dg: Disk group groupname: import failed: Disk group has no valid
configuration copies
```

The following message indicates a recoverable error.

```
vx dg: Disk group groupname: import failed: Disk for disk group not
found
```

If some of the disks in the disk group have failed, force the disk group to be imported with the command:

```
# vx dg -f import diskgroup
```

---

**Caution** Be careful when using the `-f` option. It can cause the same disk group to be imported twice from different sets of disks, causing the disk group to become inconsistent.

---

These operations can also be performed using the `vx diskadm` utility. To deport a disk group using `vx diskadm`, select menu item 9 (Remove access to (deport) a disk group). To import a disk group, select item 8 (Enable access to (import) a disk group). The `vx diskadm import` operation checks for host import locks and prompts to see if you want to clear any that are found. It also starts volumes in the disk group.



## Reserving Minor Numbers for Disk Groups

A *device minor number* uniquely identifies some characteristic of a device to the device driver that controls that device. It is often used to identify some characteristic mode of an individual device, or to identify separate devices that are all under the control of a single controller. VxVM assigns unique device minor numbers to each object (volume, plex, subdisk, disk, or disk group) that it controls.

When you move a disk group between systems, it is possible for the minor numbers that it used on its previous system to coincide (or *collide*) with those of objects known to VxVM on the new system. To get around this potential problem, you can allocate separate ranges of minor numbers for each disk group. VxVM uses the specified range of minor numbers when it creates volume objects from the disks in the disk group. This guarantees that each volume has the same minor number across reboots or reconfigurations. Disk groups may then be moved between machines without causing device number collisions.

To set a base volume device minor number for a disk group, use the following command:

```
# vxdbg init diskgroup minor=base_minor devicename
```

VxVM chooses minor device numbers for objects created from this disk group starting at the number *base\_minor*. Minor numbers can range from 0 up to 131,071. Try to leave a reasonable number of unallocated minor numbers near the top of this range to allow for temporary device number remapping in the event that a device minor number collision may still occur.

If you do not specify the base of the minor number range for a disk group, VxVM chooses one at random. The number chosen is at least 1000, or is a multiple of 1000, and yields a usable range of 1000 device numbers. The chosen number also does not overlap within a range of 1000 of any currently imported disk groups, and it does not overlap any currently allocated volume device numbers.

---

**Note** The default policy ensures that a small number of disk groups can be merged successfully between a set of machines. However, where disk groups are merged automatically using fail-over mechanisms, you should select ranges that avoid overlap.

---

For further information on minor number reservation, see the vxdbg(1M) manual page.

## Disabling a Disk Group

To disable a disk group, unmount and stop any volumes in the disk group, and then use the following command to deport it:

```
# vxdbg deport diskgroup
```



Deporting a disk group does not actually remove the disk group. It disables use of the disk group by the system. Disks in a deported disk group can be reused, reinitialized, added to other disk groups, or imported for use on other systems. Use the `vxdg import` command to re-enable access to the disk group.

## Destroying a Disk Group

The `vxdg` command provides a `destroy` option that removes a disk group from the system and frees the disks in that disk group for reinitialization:

```
# vxdg destroy diskgroup
```

---

**Caution** This command destroys all data on the disks.

---

When a disk group is destroyed, the disks that are released can be re-used in other disk groups.

## Displaying Disk Group Information

To display information on existing disk groups, enter the following command:

```
# vxdg list
```

VxVM returns the following listing of current disk groups:

```
NAME      STATE      ID
rootdg    enabled    730344554.1025.tweety
newdg     enabled    731118794.1213.tweety
```

To display more detailed information on a specific disk group (such as `rootdg`), use the following command:

```
# vxdg list rootdg
```

The output from this command is similar to the following:

```
Group:      rootdg
dgid:       962910960.1025.bass
import-id:  0.1
flags:
version:    70
local-activation: read-write
detach-policy: local
copies:     nconfig=default nlog=default
config:     segno=0.1183 permlen=727 free=722 templen=2 loglen=110
config disk c0t10d0 copy 1 len=727 state=clean online
```



```
config disk c0t11d0 copy 1 len=727 state=clean online
log disk c0t10d0 copy 1 len=110
log disk c0t11d0 copy 1 len=110
```

To verify the disk group ID and name associated with a specific disk (for example, to import the disk group), use the following command:

```
# vxdisk -s list devicename
```

This command provides output that includes the following information for the specified disk. For example, output for disk c0t12d0 as follows:

```
Disk: c0t12d0
type:   simple
flags:  online ready private autoconfig autoimport imported
diskid: 963504891.1070.bass
dgname: newdg
dgid:   963504895.1075.bass
hostid: bass
info:   privoffset=128
```

## Displaying Free Space in a Disk Group

Before you add volumes and file systems to your system, make sure you have enough free disk space to meet your needs.

To display free space in the system, use the following command:

```
# vxdg free
```

The following is example output:

GROUP	DISK	DEVICE	TAG	OFFSET	LENGTH	FLAGS
rootdg	disk01	c0t10d0	c0t10d0	0	4444228	-
rootdg	disk02	c0t11d0	c0t11d0	0	4443310	-
newdg	newdg01	c0t12d0	c0t12d0	0	4443310	-
newdg	newdg02	c0t13d0	c0t13d0	0	4443310	-
oradg	oradg01	c0t14d0	c0t14d0	0	4443310	-

To display free space for a disk group, use the following command:

```
# vxdg -g diskgroup free
```

where *-g diskgroup* optionally specifies a disk group.

For example, to display the free space in the default disk group, `rootdg`, use the following command:

```
# vxdg -g rootdg free
```

The following is example output:

DISK	DEVICE	TAG	OFFSET	LENGTH	FLAGS
disk01	c0t10d0	c0t10d0	0	4444228	-
disk02	c0t11d0	c0t11d0	0	4443310	-

The free space is measured in sectors.

## Upgrading a Disk Group

---

**Note** This information is not applicable for platforms whose first release was VERITAS Volume Manager 3.0. However, it is applicable for subsequent releases.

---

Prior to the release of VERITAS Volume Manager 3.0, the disk group version was automatically upgraded (if needed) when the disk group was imported.

From release 3.0 of VERITAS Volume Manager, the two operations of importing a disk group and upgrading its version are separate. You can import a disk group from a previous version and use it without upgrading it.

When you want to use new features, the disk group can be upgraded. The upgrade is an explicit operation. Once the upgrade occurs, the disk group becomes incompatible with earlier releases of VxVM that do not support the new version.

Before the imported disk group is upgraded, no changes are made to the disk group to prevent its use on the release from which it was imported until you explicitly upgrade it to the current release.

Until completion of the upgrade, the disk group can be used “as is” provided there is no attempt to use the features of the current version. Attempts to use a feature of the current version that is not a feature of the version from which the disk group was imported results in an error message similar to this:

```
vxvm:vxedit: ERROR: Disk group version doesn't support feature
```

To use any of the new features, you must run the `vx dg upgrade` command to explicitly upgrade the disk group to a version that supports those features.

All disk groups have a version number associated with them. VERITAS Volume Manager releases support a specific set of disk group versions. VxVM can import and perform operations on a disk group of that version. The operations are limited by what features and operations the disk group version supports.



The table, “[Disk Group Version Assignments](#),” summarizes the VERITAS Volume Manager releases that introduce and support specific disk group versions:

Disk Group Version Assignments

VERITAS Volume Manager Release	Introduces Version	Supports Versions
1.2	10	10
1.3	15	15
2.0	20	20
2.2	30	30
2.3	40	40
2.5	50	50
3.0	60	20-40, 60
3.1	70	20-70
3.1.1	80	20-80

Importing the disk group of a previous version on a VERITAS Volume Manager 3.0 system prevents the use of features introduced since that version was released. The table, “[Features Supported by Disk Group Versions](#),” summarizes the features that are supported by disk group versions 20 through 80:

Features Supported by Disk Group Versions

Disk Group Version	New Features Supported	Previous Version Features Supported
80	VERITAS Volume Replicator (VVR) Enhancements	20, 30, 40, 50, 60, 70
70	FastResync, VERITAS Volume Replicator (VVR) Enhancements, Unrelocate	20, 30, 40, 50, 60
60	Online Relayout, Safe RAID-5 Subdisk Moves	20, 30, 40
50	SRVM (now known as VERITAS Volume Replicator or VVR)	20, 30, 40
40	Hot-Relocation	20, 30
30	VxSmartSync Recovery Accelerator	20
20	Dirty Region Logging, Disk Group Configuration Copy Limiting, Mirrored Volumes Logging, New-Style Stripes, RAID-5 Volumes, Recovery Checkpointing	



To list the version of a disk group, use this command:

```
# vxdg list dgname
```

You can also determine the disk group version by using the `vxprint` command with the `-l` format option.

To upgrade a disk group to the highest version supported by the release of VxVM that is currently running, use this command:

```
# vxdg upgrade dgname
```

By default, VxVM creates a disk group of the highest version supported by the release. For example, VERITAS Volume Manager 3.1 creates disk groups with version 70.

It may sometimes be necessary to create a disk group for an older version. The default disk group version for a disk group created on a system running VERITAS Volume Manager 3.0 would be 60. Such a disk group would not be importable on a system running VERITAS Volume Manager 2.3, which only supports up to version 40. Therefore, to create a disk group on a system running VERITAS Volume Manager 3.0 that can be imported by a system running VERITAS Volume Manager 2.3, the disk group must be created with a version of 40 or less.

To create a disk group with a previous version, specify the `-T version` option to the `vxdg init` command. For example, to create a disk group with version 40 that can be imported by a system running VxVM 2.3, use the following command:

```
# vxdg -T 40 init newdg newdg01=c0t3d0s2
```

This creates a disk group, `newdg`, which can be imported by VERITAS Volume Manager 2.3. Note that while this disk group can be imported on the VxVM 2.3 system, attempts to use features from VERITAS Volume Manager 3.0 and later releases fail.

## Managing the Configuration Daemon in VxVM

The VxVM configuration daemon (`vxconfigd`) provides the interface between VxVM commands and the kernel device drivers. `vxconfigd` handles configuration change requests from VxVM utilities, communicates the change requests to the VxVM kernel, and modifies configuration information stored on disk. `vxconfigd` also initializes VxVM when the system is booted.

The `vxdctl` command is the interface to the `vxconfigd` daemon.

You can use `vxdctl` to:

- ◆ control the operation of the `vxconfigd` daemon
- ◆ manage the initialization of the `rootdg` disk group configuration



- ◆ manipulate the contents of the `volboot` file which contains a list of disks that have `rootdg` disk group configuration databases

If your system is configured to use Dynamic Multipathing (DMP), you can also use `vxctl` to:

- ◆ reconfigure the DMP database to include disk devices newly attached to, or removed from the system
- ◆ create DMP device nodes in the directories `/dev/vx/dmp` and `/dev/vx/rdmp`
- ◆ update the DMP database with changes in path type for active/passive disk arrays. Use the utilities provided by the disk-array vendor to change the path type between primary and secondary

For more information about how to use `vxctl`, refer to the `vxctl(1M)` manual page.

# Creating and Administering Subdisks

# 4

## Introduction

This chapter describes how to create and maintain *subdisks*. Subdisks are the low-level building blocks in a VERITAS Volume Manager (VxVM) configuration that are required to create plexes and volumes.

---

**Note** Most VxVM commands require superuser or equivalent privileges.

---

## Creating Subdisks

---

**Note** Subdisks are created automatically if you use the `vxassist` command or the VERITAS Volume Manager Storage Administrator (VMSA) to create volumes. For more information, see “[Creating a Volume](#)” on page 123.

---

Use the `vxmake` command to create VxVM objects, such as subdisks:

```
# vxmake sd subdisk diskname,offset,length
```

where: *subdisk* is the name of the subdisk, *diskname* is the disk name, *offset* is the starting point (offset) of the subdisk within the disk, and *length* is the length of the subdisk

For example, to create a subdisk named `disk02-01` that starts at the beginning of disk `disk02` and has a length of 8000 sectors, use the following command:

```
# vxmake sd disk02-01 disk02,0,8000
```

---

**Note** As for all VxVM commands, the default size unit is `s`, representing a sector. Add a suffix, such as `k` for kilobyte, `m` for megabyte or `g` for gigabyte, to change the unit of size. For example, `500m` would represent 500 megabytes.

---

If you intend to use the new subdisk to build a volume, you must associate the subdisk with a plex (see “[Associating Subdisks with Plexes](#)” on page 104). Subdisks for all plex layouts (concatenated, striped, RAID-5) are created the same way.



## Displaying Subdisk Information

The `vxprint` command displays information about VxVM objects. To display general information for all subdisks, use this command:

```
# vxprint -st
```

The `-s` option specifies information about subdisks. The `-t` option prints a single-line output record that depends on the type of object being listed.

The following is example output:

SD NAME	PLEX	DISK	DISKOFFS	LENGTH	[COL/]OFF	DEVICE	MODE
SV NAME	PLEX	VOLNAME	NVOLLAYR	LENGTH	[COL/]OFF	AM/NM	MODE
sd disk01-01	vol1-01	disk01	0	102400	0	c0t10d0	ENA
sd disk02-01	vol2-01	disk02	0	102400	0	c0t10d0	ENA

You can display complete information about a particular subdisk by using this command:

```
# vxprint -l subdisk
```

For example, the following command displays all information for subdisk `disk02-01`:

```
# vxprint -l disk02-01
```

This command provides the following output:

```
Disk group: rootdg
Subdisk:  disk02-01
info:     disk=disk02 offset=0 len=205632
assoc:    vol=mvol plex=mvol-02 (offset=0)
flags:    enabled
device:   device=c2t0d1c0t10d0s2 path=/dev/vx/dmp/c2t0d1c0t10d0s4
diskdev=32/68
```

## Moving Subdisks

Moving a subdisk copies the disk space contents of a subdisk onto another subdisk. If the subdisk being moved is associated with a plex, then the data stored on the original subdisk is copied to the new subdisk. The old subdisk is dissociated from the plex, and the new subdisk is associated with the plex. The association is at the same offset within the plex as the source subdisk. To move a subdisk, use the following command:

```
# vxsd mv old_subdisk new_subdisk
```

For example, if `disk03` is to be evacuated and `disk22` has enough room on two of its subdisks, use the following command:

```
# vxsd mv disk03-01 disk22-01 disk22-02
```





For the subdisk move to work correctly, the following conditions must be met:

- ◆ The subdisks involved must be the same size.
- ◆ The subdisk being moved must be part of an active plex on an active (ENABLED) volume.
- ◆ The new subdisk must not be associated with any other plex.

See “[Moving and Unrelocating Subdisks](#)” on page 176 for information about manually relocating subdisks after hot-relocation.

## Splitting Subdisks

Splitting a subdisk divides an existing subdisk into two separate subdisks. To split a subdisk, use the following command:

```
# vxsd -s size split subdisk newsd1 newsd2
```

where *subdisk* is the name of the original subdisk, *newsd1* is the name of the first of the two subdisks to be created and *newsd2* is the name of the second subdisk to be created.

The `-s` option is required to specify the size of the *first* of the two subdisks to be created. The second subdisk occupies the remaining space used by the original subdisk.

If the original subdisk is associated with a plex before the task, upon completion of the split, both of the resulting subdisks are associated with the same plex.

To split the original subdisk into more than two subdisks, repeat the previous command as many times as necessary on the resulting subdisks.

For example, to split subdisk `disk03-02`, with size 2000 megabytes into subdisks `disk03-02`, `disk03-03`, `disk03-04` and `disk03-05`, each with size 500 megabytes, use the following commands:

```
# vxsd -s 1000m split disk03-02 disk03-02 disk03-04
# vxsd -s 500m split disk03-02 disk03-02 disk03-03
# vxsd -s 500m split disk03-04 disk03-04 disk03-05
```

## Joining Subdisks

Joining subdisks combines two or more existing subdisks into one subdisk. To join subdisks, the subdisks must be contiguous on the same disk. If the selected subdisks are associated, they must be associated with the same plex, and be contiguous in that plex. To join several subdisks, use the following command:

```
# vxsd join subdisk1 subdisk2 ... new_subdisk
```



For example, to join the contiguous subdisks `disk03-02`, `disk03-03`, `disk03-04` and `disk03-05` as subdisk `disk03-02`, use the following command:

```
# vxsd join disk03-02 disk03-03 disk03-04 disk03-05 disk03-02
```

## Associating Subdisks with Plexes

Associating a subdisk with a plex places the amount of disk space defined by the subdisk at a specific offset within the plex. The entire area that the subdisk fills must not be occupied by any portion of another subdisk. There are several ways that subdisks can be associated with plexes, depending on the overall state of the configuration.

If you have already created all the subdisks needed for a particular plex, to associate subdisks at plex creation, use the following command:

```
# vxmake plex plex sd=subdisk,...
```

For example, to create the plex `home-1` and associates subdisks `disk02-01`, `disk02-00`, and `disk02-02` with plex `home-1`, use the following command:

```
# vxmake plex home-1 sd=disk02-01,disk02-00,disk02-02
```

Subdisks are associated in order starting at offset 0. If you use this type of command, you do not have to specify the multiple commands needed to create the plex and then associate each of the subdisks with that plex. In this example, the subdisks are associated to the plex in the order they are listed (after `sd=`). The disk space defined as `disk02-01` is first, `disk02-00` is second, and `disk02-02` is third. This method of associating subdisks is convenient during initial configuration.

Subdisks can also be associated with a plex that already exists. To associate one or more subdisks with an existing plex, use the following command:

```
# vxsd assoc plex subdisk1 [subdisk2 subdisk3 ...]
```

For example, to associate subdisks named `disk02-01`, `disk02-00`, and `disk02-02` with a plex named `home-1`, use the following command:

```
# vxsd assoc home-1 disk02-01 disk02-00 disk02-01
```

If the plex is not empty, the new subdisks are added after any subdisks that are already associated with the plex, unless the `-l` option is specified with the command. The `-l` option associates subdisks at a specific offset within the plex.

The `-l` option is required if you previously created a sparse plex (that is, a plex with gaps between its subdisks) for a particular volume, and subsequently want to make the plex complete. To complete the plex, create a subdisk of a size that fits the hole in the sparse plex exactly. Then, associate the subdisk with the plex by specifying the offset of the beginning of the hole in the plex, using the following command:

```
# vxsd -l offset assoc sparse_plex exact_size_subdisk
```

---

**Note** The subdisk must be exactly the right size. VxVM does not allow the space defined for two subdisks to overlap within a plex.

---

For striped or RAID-5 plexes, use the following command to specify a column number and column offset for the subdisk to be added:

```
# vxsd -l column_#/offset assoc plex subdisk ...
```

If only one number is specified with the `-l` option for striped plexes, the number is interpreted as a column number and the subdisk is associated at the end of the column.

Alternatively, to add  $M$  subdisks at the end of each of the  $N$  columns in a striped or RAID-5 volume, you can use the following form of the `vxsd` command:

```
# vxsd assoc plex subdisk1:0 ... subdiskM:N-1
```

The following example shows how to append three subdisk to the ends of the three columns in a striped plex, `vol-01`

```
# vxsd assoc vol01-01 disk10-01:0 disk11-01:1 disk12-01:2
```

If a subdisk is filling a “hole” in the plex (that is, some portion of the volume logical address space is mapped by the subdisk), the subdisk is considered stale. If the volume is enabled, the association operation regenerates data that belongs on the subdisk. Otherwise, it is marked as stale and is recovered when the volume is started.

## Associating Log Subdisks

*Log subdisks* are defined and added to a plex that is to become part of a volume on which dirty region logging (DRL) is enabled. DRL is enabled for a volume when the volume is mirrored and has at least one log subdisk.

For a description of DRL, see “[Dirty Region Logging \(DRL\)](#)” on page 35, and “[Dirty Region Logging \(DRL\) and Cluster Environments](#)” on page 202. Log subdisks are ignored as far as the usual plex policies are concerned, and are only used to hold the dirty region log.

---

**Note** Only one log subdisk can be associated with a plex. Because this log subdisk is frequently written, care should be taken to position it on a disk that is not heavily used. Placing a log subdisk on a heavily-used disk can degrade system performance.

---

To add a log subdisk to an existing plex, use the following command:

```
# vxsd aslog plex subdisk
```



where *subdisk* is the name to be used for the log subdisk. The plex must be associated with a mirrored volume before dirty region logging takes effect.

For example, to associate a subdisk named `disk02-01` with a plex named `vol101-02`, which is already associated with volume `vol101`, use the following command:

```
# vxsd aslog vol101-02 disk02-01
```

You can also add a log subdisk to an existing volume with the following command:

```
# vxassist addlog volume disk
```

This command automatically creates a log subdisk within a log plex for the specified volume.

## Dissociating Subdisks from Plexes

To break an established connection between a subdisk and the plex to which it belongs, the subdisk is *dissociated* from the plex. A subdisk is dissociated when the subdisk is removed or used in another plex. To dissociate a subdisk, use the following command:

```
# vxsd dis subdisk
```

For example, to dissociate a subdisk named `disk02-01` from the plex with which it is currently associated, use the following command:

```
# vxsd dis disk02-01
```

You can additionally remove the dissociated subdisks from VxVM control using the following form of the command:

```
# vxsd -o rm dis subdisk
```

---

**Caution** If the subdisk maps a portion of a volume's address space, dissociating it places the volume in DEGRADED mode. In this case, the `dis` operation prints a warning and must be forced using the `-o force` option to succeed. Also, if removing the subdisk makes the volume unusable, because another subdisk in the same stripe is unusable or missing and the volume is not DISABLED and empty, the operation is not allowed.

---

## Removing Subdisks

To remove a subdisk, use the following command:

```
# vxedit rm subdisk
```

For example, to remove a subdisk named `disk02-01`, use the following command:

```
# vxedit rm disk02-01
```

## Changing Subdisk Attributes

---

**Caution** Change subdisk attributes with extreme care.

---

The `vxedit` command changes attributes of subdisks and other VxVM objects. To change subdisk attributes, use the following command:

```
# vxedit set attribute=value ... subdisk ...
```

Subdisk fields that can be changed using the `vxedit` command include:

- ◆ `name`
- ◆ `putiln`
- ◆ `tutiln`
- ◆ `len`
- ◆ `comment`

The `putiln` field attributes are maintained on reboot; `tutiln` fields are temporary and are not retained on reboot. VxVM sets the `putil0` and `tutil0` utility fields. Other VERITAS products such as the VERITAS Volume Manager Storage Administrator (VMSA) set the `putil1` and `tutil1` fields. The `putil2` and `tutil2` are available for use by you for site-specific purposes. The length field, `len`, can only be changed if the subdisk is dissociated.

For example, to change the comment field of a subdisk named `disk02-01`, use the following command:

```
# vxedit set comment="subdisk comment" disk02-01
```

To prevent a particular subdisk from being associated with a plex, set the `putil0` field to a non-null string, as shown in the following command:

```
# vxedit set putil0="DO-NOT-USE" disk02-01
```

See the `vxedit(1M)` manual page for more information about using the `vxedit` command to change the attribute fields of VxVM objects.





## Introduction

This chapter describes how to create and maintain *plexes*. Plexes are logical groupings of subdisks that create an area of disk space independent of physical disk size or other restrictions. Replication (mirroring) of disk data is set up by creating multiple data plexes for a single volume. Each data plex in a mirrored volume contains an identical copy of the volume data. Because each data plex must reside on different disks from the other plexes, the replication provided by mirroring prevents data loss in the event of a single-point disk-subsystem failure. Multiple data plexes also provide increased data integrity and reliability.

---

**Note** Most VxVM commands require superuser or equivalent privileges.

---

## Creating Plexes

---

**Note** Plexes are created automatically if you use the `vxassist` command or the VERITAS Volume Manager Storage Administrator (VMSA) to create volumes. For more information, see “[Creating a Volume](#)” on page 123.

---

Use the `vxmake` command to create VxVM objects, such as plexes. When creating a plex, identify the subdisks that are to be associated with it:

To create a plex from existing subdisks, use the following command:

```
# vxmake plex plex sd=subdisk1[, subdisk2, ...]
```

For example, to create a concatenated plex named `vol01-02` using two existing subdisks named `disk02-01` and `disk02-02`, use the following command:

```
# vxmake plex vol01-02 sd=disk02-01,disk02-02
```



## Creating a Striped Plex

To create a striped plex, you must specify additional attributes. For example, to create a striped plex named `p1-01` with a stripe width of 32 sectors and 2 columns, use the following command:

```
# vxmake plex p1-01 layout=stripe stwidth=32 ncolumn=2 \  
sd=disk01-01,disk02-01
```

To use a plex to build a volume, you must associate the plex with the volume. For more information, see the section, “[Attaching and Associating Plexes](#)” on page 115.

## Displaying Plex Information

Listing plexes helps identify free plexes for building volumes. Use the `plex (-p)` option to the `vxprint` command to list information about all plexes.

To display detailed information about all plexes in the system, use the following command:

```
# vxprint -lp
```

To display detailed information about a specific plex, use the following command:

```
# vxprint -l plex
```

The `-t` option prints a single line of information about the plex. To list free plexes, use the following command:

```
# vxprint -pt
```

The following section describes the meaning of the various plex states that may be displayed in the `STATE` field of `vxprint` output.

## Plex States

Plex states reflect whether or not plexes are complete and are consistent copies (mirrors) of the volume contents. VxVM utilities automatically maintain the plex state. However, if a volume should not be written to because there are changes to that volume and if a plex is associated with that volume, you can modify the state of the plex. For example, if a disk with a particular plex located on it begins to fail, you can temporarily disable that plex.

---

**Note** A plex does not have to be associated with a volume. A plex can be created with the `vxmake plex` command and be attached to a volume later.

---



VxVM utilities use plex states to:

- ◆ indicate whether volume contents have been initialized to a known state
- ◆ determine if a plex contains a valid copy (mirror) of the volume contents
- ◆ track whether a plex was in active use at the time of a system failure
- ◆ monitor operations on plexes

This section explains the individual plex states in detail. For more information about the possible transitions between plex states and how these are applied during volume recovery, see the chapter “Understanding the Plex State Cycle” in the section “Recovery from Hardware Failure” in the *VERITAS Volume Manager Troubleshooting Guide*.

Plexes that are associated with a volume have one of the following states:

### ACTIVE Plex State

A plex can be in the ACTIVE state in two ways:

- ◆ when the volume is started and the plex fully participates in normal volume I/O (the plex contents change as the contents of the volume change)
- ◆ when the volume is stopped as a result of a system crash and the plex is ACTIVE at the moment of the crash

In the latter case, a system failure can leave plex contents in an inconsistent state. When a volume is started, VxVM does the recovery action to guarantee that the contents of the plexes marked as ACTIVE are made identical.

---

**Note** On a system running well, ACTIVE should be the most common state you see for any volume plexes.

---

### CLEAN Plex State

A plex is in a CLEAN state when it is known to contain a consistent copy (mirror) of the volume contents and an operation has disabled the volume. As a result, when all plexes of a volume are clean, no action is required to guarantee that the plexes are identical when that volume is started.

### EMPTY Plex State

Volume creation sets all plexes associated with the volume to the EMPTY state to indicate that the plex is not yet initialized.



## IOFAIL Plex State

The IOFAIL plex state is associated with persistent state logging. When the `vxconfigd` daemon detects an uncorrectable I/O failure on an ACTIVE plex, it places the plex in the IOFAIL state to exclude it from the recovery selection process at volume start time.

This state indicates that the plex is out-of-date with respect to the volume, and that it requires complete recovery. It is likely that one or more of the disks associated with the plex should be replaced.

## LOG Plex State

The state of a dirty region logging (DRL) or RAID-5 log plex is always set to LOG.

## OFFLINE Plex State

The `vxmend off` task indefinitely detaches a plex from a volume by setting the plex state to OFFLINE. Although the detached plex maintains its association with the volume, changes to the volume do not update the OFFLINE plex. The plex is not updated until the plex is put online and reattached with the `vxplex att` task. When this occurs, the plex is placed in the STALE state, which causes its contents to be recovered at the next `vxvol start` operation.

## SNAPTMP

Used during a `vxassist snapstart` operation when a snapshot is being prepared on a volume.

## SNAPDONE

Indicates that a snapshot plex is ready for a snapshot to be taken using `vxassist snapshot`.

## STALE Plex State

If there is a possibility that a plex does not have the complete and current volume contents, that plex is placed in the STALE state. Also, if an I/O error occurs on a plex, the kernel stops using and updating the contents of that plex, and the plex state is set to STALE.

A `vxplex att` operation recovers the contents of a STALE plex from an ACTIVE plex. Atomic copy operations copy the contents of the volume to the STALE plexes. The system administrator can force a plex to the STALE state with a `vxplex det` operation.

## TEMP Plex State

Setting a plex to the TEMP state eases some plex operations that cannot occur in a truly atomic fashion. For example, attaching a plex to an enabled volume requires copying volume contents to the plex before it can be considered fully attached.

A utility sets the plex state to TEMP at the start of such an operation and to an appropriate state at the end of the operation. If the system fails for any reason, a TEMP plex state indicates that the operation is incomplete. A later `vxvol start` dissociates plexes in the TEMP state.

## TEMPRM Plex State

A TEMPRM plex state is similar to a TEMP state except that at the completion of the operation, the TEMPRM plex is removed. Some subdisk operations require a temporary plex. Associating a subdisk with a plex, for example, requires updating the subdisk with the volume contents before actually associating the subdisk. This update requires associating the subdisk with a temporary plex, marked TEMPRM, until the operation completes and removes the TEMPRM plex.

If the system fails for any reason, the TEMPRM state indicates that the operation did not complete successfully. A later operation dissociates and removes TEMPRM plexes.

## TEMPRMSD Plex State

The TEMPRMSD plex state is used by `vxassist` when attaching new data plexes to a volume. If the synchronization operation does not complete, the plex and its subdisks are removed.

## Plex Condition Flags

`vxprint` may also display one of the following condition flags in the STATE field:

### NODEVICE Plex Condition

A physical device could not be found corresponding to the disk ID in the disk media record for one of the subdisks associated with the plex. The plex cannot be used until this condition is fixed, or the affected subdisk is dissociated.



## RECOVER Plex Condition

A disk corresponding to one of the disk media records was replaced, or was reattached too late to prevent the plex from becoming out-of-date with respect to the volume. The plex required complete recovery from another plex in the volume to synchronize its contents.

## REMOVED Plex Condition

Set in the disk media record when one of the subdisks associated with the plex is removed. The plex cannot be used until this condition is fixed, or the affected subdisk is dissociated.

## Plex Kernel States

The *plex kernel state* indicates the accessibility of the plex to the volume driver which monitors it.

---

**Note** No user intervention is required to set these states; they are maintained internally. On a system that is operating properly, all plexes are enabled.

---

The following plex kernel states are defined:

### DETACHED Plex Kernel State

Maintenance is being performed on the plex. Any write request to the volume is not reflected in the plex. A read request from the volume is not satisfied from the plex. Plex operations and `ioctl` function calls are accepted.

### DISABLED Plex Kernel State

The plex is offline and cannot be accessed.

### ENABLED Plex Kernel State

The plex is online. A write request to the volume is reflected in the plex. A read request from the volume is satisfied from the plex.

## Attaching and Associating Plexes

A plex becomes a participating plex for a volume by attaching it to a volume. (Attaching a plex associates it with the volume and enables the plex for use.) To attach a plex to an existing volume, use the following command:

```
# vxplex att volume plex
```

For example, to attach a plex named `vol01-02` to a volume named `vol01`, use the following command:

```
# vxplex att vol01 vol01-02
```

If the volume does not already exist, a plex (or multiple plexes) can be associated with the volume when it is created using the following command:

```
# vxmake -U usetype vol volume plex=plex1[,plex2...]
```

For example, to create a mirrored, `fsgen`-type volume named `home`, and to associate two existing plexes named `home-1` and `home-2` with `home`, use the following command:

```
# vxmake -hfsgen vol home plex=home-1,home-2
```

---

**Note** You can also use the command `vxassist mirror volume` to add a data plex as a mirror to an existing volume.

---

## Taking Plexes Offline

Once a volume has been created and placed online (`ENABLED`), VxVM can temporarily disconnect plexes from the volume. This is useful, for example, when the hardware on which the plex resides needs repair or when a volume has been left unstartable and a source plex for the volume revive must be chosen manually.

Resolving a disk or system failure includes taking a volume offline and attaching and detaching its plexes. The two commands used to accomplish disk failure resolution are `vxmend` and `vxplex`.

To take a plex `OFFLINE` so that repair or maintenance can be performed on the physical disk containing subdisks of that plex, use the following command:

```
# vxmend off plex
```

If a disk has a head crash, put all plexes that have associated subdisks on the affected disk `OFFLINE`. For example, if plexes `vol01-02` and `vol02-02` had subdisks on a drive to be repaired, use the following command to take these plexes offline:

```
# vxmend off vol01-02 vol02-02
```



This command places `vol101-02` and `vol102-02` in the `OFFLINE` state, and they remain in that state until it is changed. The plexes are not automatically recovered on rebooting the system.

## Detaching Plexes

To temporarily detach one data plex in a mirrored volume, use the following command:

```
# vxplex det plex
```

For example, to temporarily detach a plex named `vol101-02` and place it in maintenance mode, use the following command:

```
# vxplex det vol101-02
```

This command temporarily detaches the plex, but maintains the association between the plex and its volume. However, the plex is not used for I/O. A plex detached with the preceding command is recovered at system reboot. The plex state is set to `STALE`, so that if a `vxvol start` command is run on the appropriate volume (for example, on system reboot), the contents of the plex is recovered and made `ACTIVE`.

When the plex is ready to return as an active part of its volume, follow the procedures in the following section, “[Reattaching Plexes](#).”

## Reattaching Plexes

When a disk has been repaired or replaced and is again ready for use, the plexes must be put back online (plex state set to `ACTIVE`). To set the plexes to `ACTIVE`, use one of the following procedures depending on the state of the volume.

- ◆ If the volume is currently `ENABLED`, use the following command to reattach the plex:

```
# vxplex att volume plex ...
```

For example, for a plex named `vol101-02` on a volume named `vol101`, use the following command:

```
# vxplex att vol101 vol101-02
```

As when returning an `OFFLINE` plex to `ACTIVE`, this command starts to recover the contents of the plex and, after the revive is complete, sets the plex utility state to `ACTIVE`.

- ◆ If the volume is not in use (not `ENABLED`), use the following command to re-enable the plex for use:

```
# vxmend on plex
```

For example, to re-enable a plex named `vol101-02`, enter:

```
# vxmend on vol01-02
```

In this case, the state of `vol01-02` is set to `STALE`. When the volume is next started, the data on the plex is revived from another plex, and incorporated into the volume with its state set to `ACTIVE`.

If the `vxinfo` command shows that the volume is unstartable (see “Listing Unstartable Volumes” in the section “Recovery from Hardware Failure” in the *VERITAS Volume Manager Troubleshooting Guide*), set one of the plexes to `CLEAN` using the following command:

```
# vxmend fix clean plex
```

Start the volume using the following command:

```
# vxvol start volume
```

## Moving Plexes

Moving a plex copies the data content from the original plex onto a new plex. To move a plex, use the following command:

```
# vxplex mv original_plex new_plex
```

For a move task to be successful, the following criteria must be met:

- ◆ The old plex must be an active part of an active (`ENABLED`) volume.
- ◆ The new plex must be at least the same size or larger than the old plex.
- ◆ The new plex must not be associated with another volume.

The size of the plex has several implications:

- ◆ If the new plex is smaller or more sparse than the original plex, an incomplete copy is made of the data on the original plex. If an incomplete copy is desired, use the `-o force` option to `vxplex`.
- ◆ If the new plex is longer or less sparse than the original plex, the data that exists on the original plex is copied onto the new plex. Any area that is not on the original plex, but is represented on the new plex, is filled from other complete plexes associated with the same volume.
- ◆ If the new plex is longer than the volume itself, then the remaining area of the new plex above the size of the volume is not initialized and remains unused.



## Copying Plexes

This task copies the contents of a volume onto a specified plex. The volume to be copied must not be enabled. The plex cannot be associated with any other volume. To copy a plex, use the following command:

```
# vxplex cp volume new_plex
```

After the copy task is complete, *new\_plex* is not associated with the specified volume *volume*. The plex contains a complete copy of the volume data. The plex that is being copied should be the same size or larger than the volume. If the plex being copied is larger than the volume, an incomplete copy of the data results. For the same reason, *new\_plex* should not be sparse.

## Dissociating and Removing Plexes

When a plex is no longer needed, you can dissociate it from its volume and remove it as an object from VxVM. You might want to remove a plex for the following reasons:

- ◆ to provide free disk space
- ◆ to reduce the number of mirrors in a volume so you can increase the length of another mirror and its associated volume. When the plexes and subdisks are removed, the resulting space can be added to other volumes
- ◆ to remove a temporary mirror that was created to back up a volume and is no longer needed
- ◆ to change the layout of a plex

---

**Caution** To save the data on a plex to be removed, the configuration of that plex must be known. Parameters from that configuration (stripe unit size and subdisk ordering) are critical to the creation of a new plex to contain the same data. Before a plex is removed, you must record its configuration. See [“Displaying Plex Information”](#) on page 110” for more information.

---

To dissociate a plex from the associated volume and remove it as an object from VxVM, use the following command:

```
# vxplex -o rm dis plex
```

For example, to dissociate and remove a plex named `v0101-02`, use the following command:

```
# vxplex -o rm dis v0101-02
```

This command removes the plex `v0101-02` and all associated subdisks.



Alternatively, you can first dissociate the plex and subdisks, and then remove them with the following commands:

```
# vxplex dis plex
# vxedit -r rm plex
```

When used together, these commands produce the same result as the `vxplex -o rm dis` command. The `-r` option to `vxedit rm` recursively removes all objects from the specified object downward. In this way, a plex and its associated subdisks can be removed by a single `vxedit` command.

## Changing Plex Attributes

---

**Caution** Change plex attributes with extreme care.

---

The `vxedit` command changes the attributes of plexes and other volume Manager objects. To change plex attributes, use the following command:

```
# vxedit set attribute=value ... plex
```

Plex fields that can be changed using the `vxedit` command include:

- ◆ name
- ◆ `putiln`
- ◆ `ptutiln`
- ◆ `pcomment`

The `putiln` field attributes are maintained on reboot; `tutiln` fields are temporary and are not retained on reboot. VxVM sets the `putil0` and `tutil0` utility fields. Other VERITAS products such as VMSA set the `putil1` and `tutil1` fields. The `putil2` and `tutil2` are available for use by you for site-specific purposes.

The following example command sets the comment field, and also sets `tutil2` to indicate that the subdisk is in use:

```
# vxedit set comment="plex comment" tutil2="u" vol01-02
```

To prevent a particular plex from being associated with a volume, set the `putil0` field to a non-null string, as shown in the following command:

```
# vxedit set putil0="DO-NOT-USE" vol01-02
```

See the `vxedit(1M)` manual page for more information about using the `vxedit` command to change the attribute fields of VxVM objects.





## Introduction

This chapter describes how to create *volumes* in VERITAS Volume Manager (VxVM). Volumes are logical devices appear as physical disk partition devices to data management systems. Volumes enhance recovery from hardware failure, data availability, performance, and storage configuration.

Volumes are created to take advantage of the VxVM concept of virtual disks. A file system can be placed on the volume to organize the disk space with files and directories. In addition, you can configure applications such as databases to organize data on volumes.

---

**Note** Disks and disk groups must be initialized and defined to VxVM before volumes can be created from them. See [“Administering Disks”](#) on page 43 and [“Creating and Administering Disk Groups”](#) on page 83 for more information.

---

## Types of Volume Layouts

VxVM allows you to create volumes with the following layout types:

- ◆ **Concatenated**—A volume whose subdisks are arranged both sequentially and contiguously within a plex. Concatenation allows a volume to be created from multiple regions of one or more disks if there is not enough space for an entire volume on a single region of a disk. For more information, see [“Concatenation and Spanning”](#) on page 13.
- ◆ **Striped**—A volume with data spread evenly across multiple disks. *Stripes* are equal-sized fragments that are allocated alternately and evenly to the subdisks of a single plex. There must be at least two subdisks in a striped plex, each of which must exist on a different disk. Throughput increases with the number of disks across which a plex is striped. Striping helps to balance I/O load in cases where high traffic areas exist on certain subdisks. For more information, see [“Striping \(RAID-0\) in VxVM”](#) on page 15.



- ◆ **Mirrored**—A volume with multiple data plexes that duplicate the information contained in a volume. Although a volume can have a single data plex, at least two are required for true mirroring to provide redundancy of data. For the redundancy to be useful, each of these data plexes should contain disk space from different disks. For more information, see [“Mirroring \(RAID-1\) in VxVM”](#) on page 18.
- ◆ **RAID-5**—A volume that uses striping to spread data and parity evenly across multiple disks in an array. Each stripe contains a parity stripe unit and data stripe units. Parity can be used to reconstruct data if one of the disks fails. In comparison to the performance of striped volumes, write throughput of RAID-5 volumes decreases since parity information needs to be updated each time data is accessed. However, in comparison to mirroring, the use of parity reduces the amount of space required. For more information, see [“RAID-5 in VxVM”](#) on page 22.
- ◆ **Mirrored-stripe**—A volume that is configured as a striped plex and another plex that mirrors the striped one. This requires at least two disks for striping and one or more other disks for mirroring (depending on whether the plex is simple or striped). The advantages of this layout are increased performance by spreading data across multiple disks and redundancy of data. [“Striping Plus Mirroring \(Mirrored-Stripe or RAID-0+1\)”](#) on page 19.
- ◆ **Layered Volume**—A volume constructed from other volumes. Non-layered volumes are constructed by mapping their subdisks to VM disks. Layered volumes are constructed by mapping their subdisks to underlying volumes (known as *storage volumes*), and allow the creation of more complex forms of logical layout. For more information, see [“Layered Volumes”](#) on page 27.

---

**Note** You may need an additional license to use the layered volume feature.

---

Examples of layered volumes are *striped-mirror* and *concatenated-mirror* volumes.

---

**Note** The VERITAS Volume Manager Storage Administrator (VMSA) terms a striped-mirror volume as *Striped-Pro*, and a concatenated-mirror volume as *Concatenated-Pro*.

---

A striped-mirror volume is created by configuring several mirrored volumes as the columns of a striped volume. This layout offers the same benefits as a non-layered mirrored-stripe volume. In addition it provides faster recovery as the failure of single disk does not force an entire striped plex offline. For more information, see [“Mirroring Plus Striping \(Striped-Mirror, RAID-1+0 or RAID-10\)”](#) on page 20.

A concatenated-mirror volume is created by concatenating several mirrored volumes. This provides faster recovery as the failure of single disk does not force the entire mirror offline.

---

## Creating a Volume

You can create volumes using either an *advanced* approach or an *assisted* approach. Each method uses different tools although you may switch from one set to another at will.

---

**Note** Most VxVM commands require superuser or equivalent privileges.

---

### Advanced Approach

The advanced approach consists of a number of commands that typically require you to specify detailed input. These commands use a “building block” approach that requires you to have a detailed knowledge of the underlying structure and components to manually perform the commands necessary to accomplish a certain task. Advanced operations are performed using several different VxVM commands.

The steps to create a volume using this approach are:

1. Create subdisks using `vxmake sd`; see “[Creating Subdisks](#)” on page 101.
2. Create plexes using `vxmake plex`, and associate subdisks with them; see “[Creating Plexes](#)” on page 109, “[Associating Subdisks with Plexes](#)” on page 104 and “[Creating a Volume using vxmake](#)” on page 133.
3. Associate plexes with the volume using `vxmake vol`; see “[Creating a Volume using vxmake](#)” on page 133.
4. Initialize the volume using `vxvol start` or `vxvol init zero`; see “[Initializing a Volume](#)” on page 136.

See “[Creating a Volume Using a vxmake Description File](#)” on page 135 for an example of how you can combine steps 1 through 3 using a volume description file with `vxmake`.

See “[Creating a Volume using vxmake](#)” on page 133 for an example of how to perform steps 2 and 3 to create a RAID-5 volume.

### Assisted Approach

The assisted approach takes information about what you want to accomplish and then performs the necessary underlying tasks. This approach requires only minimal input from you, but also permits more detailed specifications.



Assisted operations are performed primarily through the `vxassist` command or the VMSA. `vxassist` and the VMSA create the required plexes and subdisks using only the basic attributes of the desired volume as input. Additionally, they can modify existing volumes while automatically modifying any underlying or associated objects.

Both `vxassist` and VMSA use default values for many volume attributes, unless you provide specific values. They do not require you to have a thorough understanding of low-level VxVM concepts, `vxassist` and VMSA do not conflict with other VxVM commands or preclude their use. Objects created by `vxassist` and VMSA are compatible and inter-operable with objects created by other VxVM commands and interfaces.

For more information about the VMSA, see the *VERITAS Volume Manager Storage Administrator Administrator's Guide*.

## Using vxassist

You can use the `vxassist` command to create and modify volumes. Specify the basic requirements for volume creation or modification, and `vxassist` performs the necessary tasks.

The advantages of using `vxassist` rather than the advanced approach include:

- ◆ Most actions require that you enter only one command rather than several.
- ◆ You are required to specify only minimal information to `vxassist`. If necessary, you can specify additional parameters to modify or control its actions.
- ◆ Operations result in a set of configuration changes that either succeed or fail as a group, rather than individually. System crashes or other interruptions do not leave intermediate states that you have to clean up. If `vxassist` finds an error or an exceptional condition, it exits after leaving the system in the same state as it was prior to the attempted operation.

`vxassist` helps you perform the following tasks:

- ◆ create volumes
- ◆ create mirrors for existing volumes
- ◆ grow or shrink existing volumes
- ◆ backup volumes online
- ◆ reconfigure a volume's layout online

`vxassist` obtains most of the information it needs from sources other than your input. `vxassist` obtains information about the existing objects and their layouts from the objects themselves.

For tasks requiring new disk space, `vxassist` seeks out available disk space and allocates it in the configuration that conforms to the layout specifications and that offers the best use of free space.

The `vxassist` command takes this form:

```
# vxassist [options] keyword volume [attributes...]
```

where *keyword* selects the task to perform. The first argument after a `vxassist` keyword, *volume*, is a volume name, which is followed by a set of desired volume attributes. For example, the keyword `make` allows you to create a new volume:

```
# vxassist [options] make volume length [attributes]
```

The *length* of the volume can be specified in sectors, kilobytes, megabytes, or gigabytes using a suffix character of `s`, `k`, `m`, or `g`. If no suffix is specified, the size is assumed to be in sectors. See the `vxintro(1M)` manual page for more information on specifying units.

Additional attributes can be specified as appropriate, depending on the characteristics that you wish the volume to have. Examples are stripe unit width, number of columns in a RAID-5 or stripe volume, number of mirrors, number of logs, and log type.

By default, the `vxassist` command creates volumes in the `rootdg` disk group. To use a different disk group, specify the `-g diskgroup` option to `vxassist`.

For details of available `vxassist` keywords and attributes, refer to the `vxassist(1M)` manual page.

The section, “[Creating a Volume on Any Disk](#)” on page 127 describes the simplest way to create a volume with default attributes. Later sections describe how to create volumes with specific attributes. For example, “[Creating a Volume on Specific Disks](#)” on page 128 describes how to control how `vxassist` uses the available storage space.

## Setting Default Values for vxassist

The default values that the `vxassist` command uses are listed in the file `/etc/default/vxassist`. The defaults listed in this file take effect if you do not override them on the command line, or in an alternate defaults file that you nominate using the `-d` option. A default value specified on the command line always takes precedence. `vxassist` also has a set of built-in defaults that it uses if it cannot find a value defined elsewhere.

The format of entries in a defaults file is a list of attribute-value pairs separated by new lines. These attribute-value pairs are the same as those specified as options on the `vxassist` command line. Refer to the `vxassist(1M)` manual page for details.



The following is a sample vxassist defaults file:

```
# by default:
# create unmirrored, unstriped volumes
# allow allocations to span drives
# with RAID-5 create a log, with mirroring don't create a log
# align allocations on cylinder boundaries
layout=nomirror,nostripe,span,nocontig,raid5log,noregionlog,
diskalign

# use the fsgen usage type, except when creating RAID-5 volumes
usetype=fsgen

# allow only root access to a volume
mode=u=rw,g=,o=
user=root
group=root

# when mirroring, create two mirrors
nmirror=2

# for regular striping, by default create between 2 and 8 stripe
# columns
max_nstripe=8
min_nstripe=2

# for RAID-5, by default create between 3 and 8 stripe columns
max_nraid5stripe=8
min_nraid5stripe=3

# by default, create 1 log copy for both mirroring and RAID-5 volumes
nregionlog=1
nraid5log=1

# by default, limit mirroring log lengths to 32Kbytes
max_regionloglen=32k

# use 64K as the default stripe unit size for regular volumes
stripe_stwid=64k

# use 16K as the default stripe unit size for RAID-5 volumes
raid5_stwid=16k
```



## Discovering the Maximum Size of a Volume

To find out how large a volume you can create within a disk group, use the following form of the `vxassist` command:

```
# vxassist -g diskgroup maxsize layout=layout [attributes]
```

For example, to discover the maximum size of RAID-5 volume with 5 columns and 2 logs that you can create within the disk group `dgrp`, enter the following command:

```
# vxassist -g dgrp maxsize layout=raid5 nlog=2
```

You can use storage attributes if you want to restrict the disks that `vxassist` uses when creating volumes. See “[Creating a Volume on Specific Disks](#)” on page 128 for more information.

## Creating a Volume on Any Disk

By default, the `vxassist make` command creates a concatenated volume that uses one or more sections of disk space. On a fragmented disk, this allows you to put together a volume larger than any individual section of free disk space available.

---

**Note** To change the default layout, edit the definition of the `layout` attribute defined in the `/etc/default/vxassist` file.

---

If there is not enough space on a single disk, `vxassist` creates a spanned volume. A spanned volume is a concatenated volume with sections of disk space spread across more than one disk. A spanned volume can be larger than any disk on a system, since it takes space from more than one disk.

To create a concatenated, default volume, use the following form of the `vxassist` command:

```
# vxassist make volume length
```

For example, to create the concatenated volume `voldefault` with a length of 10 gigabytes in the `rootdg` disk group:

```
# vxassist make voldefault 10g
```



## Creating a Volume on Specific Disks

VxVM automatically selects the disks on which each volume resides, unless you specify otherwise. If you want a volume to be created on specific disks, you must designate those disks to VxVM. More than one disk can be specified.

To create a volume on a specific disk or disks, use the following command:

```
# vxassist make volume length [layout=layout] diskname ...
```

For example, to create the volume `volspec` with length 5 gigabytes on `disk03` and `disk04`, use the following command:

```
# vxassist make volspec 5g disk03 disk04
```

The `vxassist` command allows you to specify storage attributes. These allow you fine control over the devices, including disks, controllers and targets on controllers, which `vxassist` will use to configure a volume. For example, you can specifically exclude `disk05`:

```
# vxassist make volspec 5g !disk05
```

or exclude all disks that are on controller `c2`:

```
# vxassist make volspec 5g !ctlr:c2
```

or include only disks on controller `c1` except for target `t5`:

```
# vxassist make volspec 5g ctlr:c1 !target:c1t5
```

If you want a volume to be created using only disks from a specific disk group, use the `-g` option to `vxassist`, for example:

```
# vxassist -g bigone make volmega 20g disk10 disk11
```

or alternatively, use the `diskgroup` attribute:

```
# vxassist make volmega 20g diskgroup=bigone disk10 disk11
```

---

**Note** Any storage attributes that you specify for use must belong to the disk group. Otherwise, `vxassist` will not use them to create a volume.

---

You can also use storage attributes to control how `vxassist` uses available storage, for example, when calculating the maximum size of a volume, when growing a volume or when removing mirrors or logs from a volume. The following example excludes disks `disk07` and `disk08` when calculating the maximum size of RAID-5 volume that `vxassist` can create using the disks in the disk group `dg`:

```
# vxassist -g dgrp maxsize layout=raid5 nlog=2 !disk07 !disk08
```

See the `vxassist(1M)` manual page for more information about using storage attributes.

## Creating a Mirrored Volume

A mirrored volume provides data redundancy by containing more than one copy of its data. Each copy (or mirror) is stored on different disks from the original copy of the volume and from other mirrors. Mirroring a volume ensures that its data is not lost if a disk in one of its component mirrors fails.

---

**Note** A mirrored volume requires space to be available on at least as many disks in the disk group as the number of mirrors in the volume.

---

To create a new mirrored volume, use the following command:

```
# vxassist make volume length layout=mirror [nmirror=number]
```

For example, to create the mirrored volume, `volmir`, use the following command:

```
# vxassist make volmir 5g layout=mirror
```

To create a volume with 3 instead of the default of 2 mirrors, modify the command to read:

```
# vxassist make volmir 5g layout=mirror nmirror=3
```

## Creating a Mirrored-Concatenated Volume

A mirrored-concatenated volume mirrors several concatenated plexes. To create a concatenated-mirror volume, use the following command:

```
# vxassist make volume length layout=mirror-concat \  
  [nmirror=number]
```

Alternatively, first create a concatenated volume, and then mirror it as described in [“Adding a Mirror to a Volume”](#) on page 144.

## Creating a Concatenated-Mirror Volume

---

**Note** VxVM supports this feature for private disk groups, but not for shareable disk groups in a cluster environment.

---

A concatenated-mirror volume is an example of a layered volume which concatenates several underlying mirror volumes. To create a concatenated-mirror volume, use the following command:

```
# vxassist make volume length layout=concat-mirror \  
  [nmirror=number]
```



## Creating a Mirrored Volume with Logging Enabled

To create a mirrored volume with Dirty Region Logging (DRL) enabled, use this command:

```
# vxassist make volume length layout=mirror,log
```

---

**Note** By default, the `vxassist` command creates one log plex for a mirrored volume.

---

For a volume that will be written to sequentially, such as a database log volume, use the following command to specify that sequential DRL is to be used:

```
# vxassist make volume length layout=mirror,log logtype=drlseq
```

If you need to add more logs to a volume at a later date, follow the procedure described in [“Adding a DRL Log to a Mirrored Volume”](#) on page 147.

## Creating a Striped Volume

A striped volume contains at least one plex that consists of two or more subdisks located on two or more physical disks. For more information on striping, see [“Striping \(RAID-0\) in VxVM”](#) on page 15 and [“Striping Guidelines”](#) on page 72.

---

**Note** A striped volume requires space to be available on at least as many disks in the disk group as the number of columns in the volume.

---

To create a striped volume, use the following command:

```
# vxassist make volume length layout=stripe
```

For example, to create the 10-gigabyte striped volume `volzebra`, use the following command:

```
# vxassist make volzebra 10g layout=stripe
```

This creates a striped volume with the default stripe unit size (64 kilobytes) and the default number of stripes (2).

You can specify the disks on which the volumes are to be created by including the disk names on the command line. For example, to create a 30-gigabyte striped volume on three specific disks, `disk03`, `disk04`, and `disk05`, use the following command:

```
# vxassist make stripevol 30g layout=stripe disk03 disk04 disk05
```

To change the default number of columns from 2, or the stripe width from 64 kilobytes, use the `ncolumn` and `stripeunit` modifiers with `vxassist`. For example, the following command creates a striped volume with 5 columns and a 32-kilobyte stripe size:

```
# vxassist make stripevol 30g layout=stripe stripeunit=32k ncol=5
```

## Creating a Mirrored-Stripe Volume

A mirrored-stripe volume mirrors several striped data plexes.

---

**Note** A mirrored-stripe volume requires space to be available on at least as many disks in the disk group as the number of mirrors multiplied by the number of columns in the volume.

---

To create a striped-mirror volume, use the following command:

```
# vxassist make volume length layout=mirror-stripe \  
[nmirror=number_mirrors] [ncol=number_columns] \  
[stripewidth=size]
```

Alternatively, first create a striped volume, and then mirror it as described in “[Adding a Mirror to a Volume](#)” on page 144. In this case, the additional data plexes may be either striped or concatenated.

## Creating a Striped-Mirror Volume

---

**Note** VxVM supports this feature for private disk groups, but not for shareable disk groups in a cluster environment.

---

A striped-mirror volume is an example of a layered volume which stripes several underlying mirror volumes.

---

**Note** A striped-mirror volume requires space to be available on at least as many disks in the disk group as the number of columns multiplied by the number of stripes in the volume.

---

To create a striped-mirror volume, use the following command:

```
# vxassist make volume length layout=stripe-mirror \  
[nmirror=number_mirrors] [ncol=number_columns] \  
[stripewidth=size]
```

By default, VxVM attempts to create the underlying volumes by mirroring subdisks rather than columns if the size of each column is greater than the value for the attribute `stripe-mirror-col-split-trigger-pt` that is defined in the `vxassist defaults` file.

If there are multiple subdisks per column, you can choose to mirror each subdisk individually instead of each column. To mirror at the subdisk level, specify the layout as `stripe-mirror-sd` rather than `stripe-mirror`. To mirror at the column level, specify the layout as `stripe-mirror-col` rather than `stripe-mirror`.



## Mirroring across Targets or Controllers

To create a volume whose mirrored data plexes lie on different controllers, use either of the following commands:

```
# vxassist make volume length layout=layout mirror=target [attributes]
```

The attribute `mirror=target` specifies that volumes should be mirrored between identical target IDs on different controllers.

```
# vxassist make volume length layout=layout mirror=ctlr [attributes]
```

The attribute `mirror=ctlr` specifies that disks in one mirror plex should not be on the same controller as disks in other mirror plexes within the same volume.

The following command creates a mirrored volume with two data plexes:

```
# vxassist make volspec 10g layout=mirror nmirror=2 mirror=ctlr \  
    ctlr:c2 ctlr:c3
```

The disks in one data plex are all attached to controller `c2`, and the disks in the other data plex are all attached to controller `c3`. This arrangement ensures continued availability of the volume should either controller fail.

## Creating a RAID-5 Volume

---

**Note** VxVM supports this feature for private disk groups, but not for shareable disk groups in a cluster environment.

---

You can create RAID-5 volumes by using either the `vxassist` command (recommended) or the `vxmake` command. Both approaches are described below.

---

**Note** A RAID-5 volume requires space to be available on at least as many disks in the disk group as the number of columns in the volume.

---

A RAID-5 volume contains a RAID-5 data plex that consists of three or more subdisks located on three or more physical disks. Only one RAID-5 data plex can exist per volume. A RAID-5 volume can also contain one or more RAID-5 log plexes, which are used to log information about data and parity being written to the volume. For more information on RAID-5 volumes, see “[RAID-5 in VxVM](#)” on page 22.

---

**Caution** Do not create a RAID-5 volume with more than 8 columns because the volume will be unrecoverable in the event of the failure of more than one disk.

---

To create a RAID-5 volume, use the following command:

```
# vxassist make volume length layout=raid5 [ncol=number_columns] \  
[stripewidth=size] [nlog=number] [loglen=log_length]
```

For example, to create the RAID-5 volume `volraid` together with 2 RAID-5 logs, use the following command:

```
# vxassist make volraid 10g layout=raid5 nlog=2
```

This creates a RAID-5 volume with the default stripe unit size on the default number of disks. It also creates two RAID-5 logs rather than the default of one log.

It is suggested that you configure a minimum of two RAID-5 log plexes for each RAID-5 volume. These log plexes should be located on different disks. Having two RAID-5 log plexes for each RAID-5 volume protects against the loss of logging information due to the failure of a single disk.

RAID-5 logs can be concatenated or striped plexes, and each RAID-5 log associated with a RAID-5 volume has a complete copy of the logging information for the volume. To support concurrent access to the RAID-5 array, the log should be several times the stripe size of the RAID-5 plex.

If you need to add more logs to a RAID-5 volume at a later date, follow the procedure described in “[Adding a RAID-5 Log](#)” on page 148.

## Creating a Volume using vxmake

---

**Note** VxVM supports the creation of layered and RAID-5 volumes for private disk groups, but not for shareable disk groups in a cluster environment.

---

As an alternative to using `vxassist`, you can create a volume using the `vxmake` command to arrange existing subdisks into plexes, and then to form these plexes into a volume. Subdisks can be created using the method described in “[Creating Subdisks](#)” on page 101.

---

**Caution** Do not create a RAID-5 volume with more than 8 columns because the volume will be unrecoverable in the event of the failure of more than one disk.

---

Creating a RAID-5 plex for a RAID-5 volume is similar to creating striped plexes, except that the `layout` attribute is set to `raid5`. Subdisks can be implicitly associated in the same way as with striped plexes. For example, to create a four-column RAID-5 plex with a stripe unit size of 32 sectors, use the following command:

```
# vxmake plex raidplex layout=raid5 stwidth=32 \  
sd=disk00-01,disk01-00,disk02-00,disk03-00
```



Note that because four subdisks are specified but not the number of columns, the `vxmake` command assumes a four-column RAID-5 plex and places one subdisk in each column. Striped plexes are created using the same method except that the layout is specified as `stripe`. If the subdisks are to be created and added later, use the following command to create the plex:

```
# vxmake plex raidplex layout=raid5 ncolumn=4 stwidth=32
```

---

**Note** If no subdisks are specified, the `ncolumn` attribute must be specified. Subdisks can be added to the plex later using the `vxsd assoc` command (see [“Associating Subdisks with Plexes”](#) on page 104).

---

If each column in a RAID-5 plex is to be created from multiple subdisks which may span several physical disks, you can specify to which column each subdisk should be added. For example, to create a three-column RAID-5 plex using six subdisks, use the following form of the `vxmake` command:

```
# vxmake plex raidplex layout=raid5 stwidth=32 \  
sd=disk00-00:0,disk01-00:1,disk02-00:2,disk03-00:0, \  
disk04-00:1,disk05-00:2
```

This command stacks subdisks `disk00-00` and `disk03-00` consecutively in column 0, subdisks `disk01-00` and `disk04-00` consecutively in column 1, and subdisks `disk02-00` and `disk05-00` in column 2. Offsets can also be specified to create sparse RAID-5 plexes, as for striped plexes.

Log plexes may be created as default concatenated plexes by not specifying a layout, for example:

```
# vxmake plex raidlog1 disk06-00  
# vxmake plex raidlog2 disk07-00
```

To create a RAID-5 volume, specify the usage type to be RAID-5 using the following command:

```
# vxmake -Uraid5 vol raidvol
```

RAID-5 plexes and RAID-5 log plexes are associated with the volume `raidvol` using the following command:

```
# vxmake -Uraid5 vol raidvol plex=raidplex,raidlog1,raidlog2
```

---

**Note** Each RAID-5 volume has one RAID-5 plex where the data and parity are stored. Any other plexes associated with the volume are used as RAID-5 log plexes to log information about data and parity being written to the volume.

---

After creating a volume using `vxmake`, you must initialize it before it can be used. The procedure is described in [“Initializing a Volume”](#) on page 136.



## Creating a Volume Using a vxmake Description File

You can use the `vxmake` command to add a new volume, plex or subdisk to the set of objects managed by VxVM. `vxmake` adds a record for each new object to the VxVM configuration database. You can create records either by specifying parameters to `vxmake` on the command line, or by using a file which contains plain-text descriptions of the objects. The file can also contain commands for performing a list of tasks. Use the following form of the command to have `vxmake` read the file from the standard input:

```
# vxmake < description_file
```

Alternatively, you can specify the file to `vxmake` using the `-d` option:

```
# vxmake -d description_file
```

The following sample description file defines a volume, `db`, with two plexes:

```
#rectyp #name          #options
sd      disk3-01      disk=disk3 offset=0 len=10000
sd      disk3-02      disk=disk3 offset=25000 len=10480
sd      disk4-01      disk=disk4 offset=0 len=8000
sd      disk4-02      disk=disk4 offset=15000 len=8000
sd      disk4-03      disk=disk4 offset=30000 len=4480
plex    db-01         layout=STRIPE ncolumn=2 stwidth=16k
                        sd=disk3-01:0/0,disk3-02:0/10000,disk4-01:1/0,\
                        disk4-02:1/8000, disk4-03:1/16000
sd      ramd1-01      disk=ramd1 len=640
                        comment="Hot spot for dbvol
plex    db-02         sd=ramd1-01:40320
vol     db            usetype=gen plex=db-01,db-02
                        readpol=prefer prefname=db-02
                        comment="Uses mem1 for hot spot in last 5m
```

The first plex, `db-01`, is striped and has five subdisks on two physical disks, `disk3` and `disk4`. The second plex, `db-02`, is the preferred plex in the mirror, and has one subdisk, `ramd1-01`, on a volatile memory disk.

For detailed information about how to use `vxmake`, refer to the `vxmake(1M)` manual page.

After creating a volume using `vxmake`, you must initialize it before it can be used. The procedure is described in the following section, “[Initializing a Volume](#)”.



## Initializing a Volume

A volume must be initialized if it was created by the `vxmake` command and has not yet been initialized, or if the volume has been set to an uninitialized state.

---

**Note** If you create a volume using the `vxassist` command, `vxassist` initializes the volume automatically unless you specify the attribute `init=none`.

---

To initialize a volume, use the following command:

```
# vxvol start volume
```

If you also want to zero out the contents of the entire volume, use this command:

```
# vxvol init zero volume
```

This command writes zeroes to any log plexes and to the entire length of the volume. It then leaves the volume in the ACTIVE state. You can also zero out a volume when using `vxassist` to create it, by specifying the attribute `init=zero`. For example, the following command creates a RAID-5 volume and zeroes it out:

```
# vxassist make volume length layout=raid5 init=zero
```

Although it is slower than a `vxvol init zero` operation, the `vxvol start` command makes the volume available for use immediately.

## Accessing a Volume

As soon as a volume has been created and initialized, it is available for use as a virtual disk partition by the operating system for the creation of a file system, or by application programs such as relational databases and other data management software.

Creating a volume in the disk group `rootdg` sets up block and character (raw) device files that can be used to access the volume:

```
/dev/vx/dsk/volume—block device file for volume
```

```
/dev/vx/rdsk/volume—character device file for volume
```

For volumes in disk groups other than `rootdg`, the pathnames include a directory named for the disk group:

```
/dev/vx/dsk/diskgroup/volume—block device file for volume
```

```
/dev/vx/rdsk/diskgroup/volume—character device file for volume
```

Use the appropriate device node to create, mount and repair file systems, and to lay out databases that require raw partitions.

# Administering Volumes

## Introduction

This chapter describes how to perform common maintenance tasks on volumes in VERITAS Volume Manager (VxVM). This includes displaying volume information, monitoring tasks, adding and removing logs, resizing volumes, removing mirrors, removing volumes, backing up volumes using mirrors and snapshots, and changing the layout of volumes without taking them offline.

---

**Note** Most VxVM commands require superuser or equivalent privileges.

---

## Displaying Volume Information

You can use the `vxprint` command to display information about how a volume is configured.

To display the volume, plex, and subdisk record information for all volumes in the system, use the following command:

```
# vxprint -ht
```

The following is example output from the `vxprint` command:

```
Disk group: rootdg
```

DG NAME	NCONFIG	NLOG	MINORS	GROUP-ID				
DM NAME	DEVICE	TYPE	PRIVLEN	PUBLEN	STATE			
V NAME	USETYPE	KSTATE	STATE	LENGTH	READPOL	PREFPLEX		
PL NAME	VOLUME	KSTATE	STATE	LENGTH	LAYOUT	NCOL/WID	MODE	
SD NAME	PLEX	DISK	DISKOFFS	LENGTH	[COL/]	OFF	DEVICE	MODE
dm disk10	<i>c1t0d0s2</i>	sliced	559	1044400	-			
dm disk20	<i>c2t0d0s2</i>	sliced	559	1044400	-			
v pubs	fsgen	ENABLED	ACTIVE	2288	SELECT	-		
pl pubs-01	pubs	ENABLED	ACTIVE	2288	CONCAT	-	RW	
sd disk10-01	pubs-01	disk10	0	2288	0		c0t0d0	ENA



```
v voldef sgen ENABLED ACTIVE 20480 SELECT -
pl voldef-01 voldef ENABLED ACTIVE 20480 CONCAT - RW
sd disk10-02 voldef-0 disk10 2288 20480 0 c0t1d0 ENA
```

where `dg` is a disk group, `dm` is a disk, `v` is a volume, `pl` is a plex, and `sd` is a subdisk. The top few lines indicate the headers that match each type of output line that follows. Each volume is listed along with its associated plexes and subdisks.

To display volume-related information for a specific volume, use the following command:

```
# vxprint -t volume
```

For example, to display information about the `voldef` volume, use the following command:

```
# vxprint -t voldef
```

This is example output from this command:

```
Disk group: rootdg
V NAME      USETYPE  KSTATE   STATE    LENGTH  READPOL  PREFPLEX
v voldef    fsgen    ENABLED  ACTIVE   20480   SELECT   -
```

The following section describes the meaning of the various volume states that may be displayed.

## Volume States

The following volume states may be displayed by VxVM commands such as `vxprint`:

### ACTIVE Volume State

The volume has been started (kernel state is currently `ENABLED`) or was in use (kernel state was `ENABLED`) when the machine was rebooted. If the volume is currently `ENABLED`, the state of its plexes at any moment is not certain (since the volume is in use).

If the volume is currently `DISABLED`, this means that the plexes cannot be guaranteed to be consistent, but are made consistent when the volume is started.

For a RAID-5 volume, if the volume is currently `DISABLED`, parity cannot be guaranteed to be synchronized.

### CLEAN Volume State

The volume is not started (kernel state is `DISABLED`) and its plexes are synchronized. For a RAID-5 volume, its plex stripes are consistent and its parity is good.

## EMPTY Volume State

The volume contents are not initialized. The kernel state is always DISABLED when the volume is EMPTY.

## NEEDSYNC Volume State

The volume requires a resynchronization operation the next time it is started. For a RAID-5 volume, a parity resynchronization operation is required.

## REPLAY Volume State

The volume is in a transient state as part of a log replay. A log replay occurs when it becomes necessary to use logged parity and data. This state is only applied to RAID-5 volumes.

## SYNC Volume State

The volume is either in read-writeback recovery mode (kernel state is currently ENABLED) or was in read-writeback mode when the machine was rebooted (kernel state is DISABLED). With read-writeback recovery, plex consistency is recovered by reading data from blocks of one plex and writing the data to all other writable plexes. If the volume is ENABLED, this means that the plexes are being resynchronized through the read-writeback recovery. If the volume is DISABLED, it means that the plexes were being resynchronized through read-writeback when the machine rebooted and therefore still need to be synchronized.

For a RAID-5 volume, the volume is either undergoing a parity resynchronization (kernel state is currently ENABLED) or was having its parity resynchronized when the machine was rebooted (kernel state is DISABLED).

---

**Note** The interpretation of these flags during volume startup is modified by the persistent state log for the volume (for example, the DIRTY / CLEAN flag). If the clean flag is set, an ACTIVE volume was not written to by any processes or was not even open at the time of the reboot; therefore, it can be considered CLEAN. The clean flag is always set in any case where the volume is marked CLEAN.

---



## Volume Kernel States

The *volume kernel state* indicates the accessibility of the volume. The volume kernel state allows a volume to have an offline (DISABLED), maintenance (DETACHED), or online (ENABLED) mode of operation.

---

**Note** No user intervention is required to set these states; they are maintained internally. On a system that is operating properly, all volumes are enabled.

---

The following volume kernel states are defined:

### DETACHED Volume Kernel State

Maintenance is being performed on the volume. The volume cannot be read or written, but plex device operations and `ioctl` function calls are accepted.

### DISABLED Volume Kernel State

The volume is offline and cannot be accessed.

### ENABLED Volume Kernel State

The volume is online and can be read from or written to.

## Monitoring and Controlling Tasks

---

**Note** VxVM supports this feature for private disk groups, but not for shareable disk groups in a cluster environment.

---

The VxVM task monitor tracks the progress of system recovery by monitoring task creation, maintenance, and completion. The task monitor allows you to monitor task progress and to modify characteristics of tasks, such as pausing and recovery rate (for example, to reduce the impact on system performance).

## Specifying Task Tags

Every task is given a unique *task identifier*. This is a numeric identifier for the task that can be specified to the `vxtask` utility to specifically identify a single task. Several VxVM utilities also provide a `-t` option to specify an alphanumeric tag of up to 16 characters in length. This allows you to group several tasks by associating them with the same tag.

The following utilities allow you to specify a tag using the `-t` option:

`vxassist`, `vxevac`, `vxplex`, `vxreattach`, `vxrecover`, `vxresize`, `vxsd`, and `vxvol`

For example, to execute a `vxrecover` command and track all the resulting tasks as a group with the task tag `myrecovery`, use the following command:

```
# vxrecover -t myrecovery -b disk05
```

Any tasks started by the utilities invoked by `vxrecover` also inherit its task ID and task tag, so establishing a parent-child task relationship.

For more information about the utilities that support task tagging, see their respective manual pages.

## Managing Tasks with `vxtask`

You can use the `vxtask` command to administer operations on VxVM tasks that are running on the system. Operations include listing tasks, modifying the state of a task (pausing, resuming, aborting) and modifying the rate of progress of a task. For detailed information about how to use `vxtask`, refer to the `vxtask(1M)` manual page.

VxVM *tasks* represent long-term operations in progress on the system. Every task gives information on the time the operation started, the size and progress of the operation, and the state and rate of progress of the operation. The administrator can change the state of a task, giving coarse-grained control over the progress of the operation. For those operations that support it, the rate of progress of the task can be changed, giving more fine-grained control over the task.

### `vxtask` Operations

The `vxtask` command supports the following operations:

`list`

Lists tasks running on the system in one-line summaries. The `-l` option prints tasks in long format. The `-h` option prints tasks hierarchically, with child tasks following the parent tasks. By default, all tasks running on the system are printed. If a `taskid` argument is supplied, the output is limited to those tasks whose `taskid` or task tag match `taskid`. The remaining arguments are used to filter tasks and limit the tasks actually listed.



`monitor`

Prints information continuously about a task or group of tasks as task information changes. This allows you to track the progression of tasks. Specifying `-l` causes a long listing to be printed. By default, short one-line listings are printed. In addition to printing task information when a task state changes, output is also generated when the task completes. When this occurs, the state of the task is printed as `EXITED`.

`pause`, `resume`, `abort`

Changes the state of a task. The `pause` operation puts a running task in the paused state, causing it to suspend operation. The `resume` operation causes a paused task to continue operation. The `abort` operation causes the specified task to cease operation. In most cases, the operations “back out” as if an I/O error occurred, reversing what has been done so far to the largest extent possible.

`set`

Changes modifiable parameters of a task. Currently, there is only one modifiable parameter, `slow[=iodelay]`, which can be used to reduce the impact that copy operations have on system performance. If `slow` is specified, this introduces a delay between such operations with a default value for `iodelay` of 250 milliseconds. The larger the value of `iodelay` that is specified, the slower is the progress of the task and the fewer system resources that it consumes in a given time. (The `slow` attribute is also accepted by the `vplex`, `vxvol` and `vxrecover` commands.)

### **vxtask Usage**

To list all tasks currently running on the system, use the following command:

```
# vxtask list
```

To print tasks hierarchically, with child tasks following the parent tasks, use the `-h` option, as follows:

```
# vxtask -h list
```

To trace all tasks in the disk group `foodg` that are currently paused, as well as any tasks with the tag `sysstart`, use the following command:

```
# vxtask -G foodg -p -i sysstart list
```

Use the `vxtask -p list` command lists all paused tasks, and use `vxtask resume` to continue execution (the task may be specified by its ID or by its tag):

```
# vxtask -p list
# vxtask resume 167
```

To monitor all tasks with the tag `myoperation`, use the following command:

```
# vxtask monitor myoperation
```



To cause all tasks tagged with `recoval1` to exit, use the following command:

```
# vxtask abort recoval1
```

This command causes VxVM to attempt to reverse the progress of the operation so far. For an example of how to use `vxtask` to monitor and modify the progress of the Online Relayout feature, see [“Controlling the Progress of a Relayout”](#) on page 165.

## Stopping a Volume

Stopping a volume renders it unavailable to the user, and changes the volume state from `ENABLED` or `DETACHED` to `DISABLED`. If the volume cannot be disabled, it remains in its current state. To stop a volume, use the following command:

```
# vxvol stop volume ...
```

For example, to stop a volume named `vol01`, use the following command:

```
# vxvol stop vol01
```

To stop all `ENABLED` volumes, use the following command:

```
# vxvol stopall
```

To stop all `ENABLED` volumes in a specified disk group, use the following command:

```
# vxvol -g diskgroup stopall
```

## Putting a Volume in Maintenance Mode

If all mirrors of a volume become `STALE`, you can place the volume in maintenance mode. Then you can view the plexes while the volume is `DETACHED` and determine which plex to use for reviving the others. To place a volume in maintenance mode, use the following command:

```
# vxvol maint volume
```

To assist in choosing the revival source plex, use `vxprint` to list the stopped volume and its plexes.

To take a plex (in this example, `vol01-02`) offline, use the following command:

```
# vxmend off vol01-02
```

The `vxmend on` command can change the state of an `OFFLINE` plex of a `DISABLED` volume to `STALE`. For example, to put a plex named `vol01-02` in the `STALE` state, use the following command:



```
# vxmend on vol101-02
```

Running the `vxvol start` command on the volume then revives the plex as described in the next section.

## Starting a Volume

Starting a volume makes it available for use, and changes the volume state from DISABLED or DETACHED to ENABLED. To start a DISABLED or DETACHED volume, use the following command:

```
# vxvol start volume ...
```

If a volume cannot be enabled, it remains in its current state.

To start all DISABLED or DETACHED volumes, enter:

```
# vxvol startall
```

Alternatively, to start a DISABLED volume, use the following command:

```
# vxrecover -s volume ...
```

To start all DISABLED volumes, enter:

```
# vxrecover -s
```

To prevent any recovery operations being performed on the volumes, additionally specify the `-n` option to `vxrecover`.

## Adding a Mirror to a Volume

A mirror can be added to an existing volume with the `vxassist` command, as follows:

```
# vxassist mirror volume
```

For example, to create a mirror of the volume `voltest`, use the following command:

```
# vxassist mirror voltest
```

Another way to mirror an existing volume is by first creating a plex, and then attaching it to a volume, using the following commands:

```
# vxmake plex plex sd=subdisk ...  
# vxplex att volume plex
```

## Mirroring All Volumes

To mirror all existing volumes on the system to available disk space, use the following command:

```
# /etc/vx/bin/vxmirror -g diskgroup -a
```

To configure VxVM to create mirrored volumes by default, use the following command:

```
# /etc/vx/bin/vxmirror -d yes
```

If you make this change, you can still make unmirrored volumes by specifying `nmirror=1` as an attribute to the `vxassist` command. For example, to create an unmirrored 20-gigabyte volume named `nomirror`, use the following command:

```
# vxassist make nomirror 20g nmirror=1
```

## Mirroring Volumes on a VM Disk

Mirroring volumes on a VM disk gives you one or more copies of your volumes in another disk location. By creating mirror copies of your volumes, you protect your system against loss of data in case of a disk failure. You can use this task on your root disk to make a second copy of the boot information available on an alternate disk. This allows you to boot your system even if your root disk is corrupted.

---

**Note** This task only mirrors concatenated volumes. Volumes that are already mirrored or that contain subdisks that reside on multiple disks are ignored.

---

To mirror volumes on a disk, make sure that the target disk has an equal or greater amount of space as the originating disk and then do the following:

1. Select menu item 6 (Mirror volumes on a disk) from the `vxdiskadm` main menu.
2. At the following prompt, enter the disk name of the disk that you wish to mirror:

```
Mirror volumes on a disk
Menu: VolumeManager/Disk/Mirror
```

```
This operation can be used to mirror volumes on a disk. These
volumes can be mirrored onto another disk or onto any
available disk space. Volumes will not be mirrored if they are
already mirrored. Also, volumes that are comprised of more than
one subdisk will not be mirrored.
```

```
Enter disk name [<disk>,list,q,?] disk02
```



3. At the following prompt, enter the target disk name (this disk must be the same size or larger than the originating disk):

```
You can choose to mirror volumes from disk disk02 onto any
available disk space, or you can choose to mirror onto a
specific disk. To mirror to a specific disk, select the name of
that disk. To mirror to any available disk space, select "any".
Enter destination disk [<disk>,list,q,?] (default: any) disk01
```

4. At the following prompt, press Return to make the mirror:

```
The requested operation is to mirror all volumes on disk disk02
in disk group rootdg onto available disk space on disk disk01.
```

```
NOTE: This operation can take a long time to complete.
```

```
Continue with operation? [y,n,q,?] (default: y)
```

```
The vxdiskadm program displays the status of the mirroring
operation, as follows:
```

```
Mirror volume voltest-bk00 ...
```

```
Mirroring of disk disk01 is complete.
```

5. At the following prompt, indicate whether you want to mirror volumes on another disk (**y**) or return to the vxdiskadm main menu (**n**):

```
Mirror volumes on another disk? [y,n,q,?] (default: n)
```

## Removing a Mirror

When a mirror is no longer needed, you can remove it to free up disk space.

---

**Note** The last valid plex associated with a volume cannot be removed.

---

To remove a mirror data plex from a volume, use the following command:

```
# vxplex remove mirror volume
```

Additionally, you can use storage attributes to specify the storage to be removed. For example, to remove a mirror on disk disk01, from volume vol01, enter:

```
# vxassist remove mirror vol01 !disk01
```

For more information about storage attributes, see [“Creating a Volume on Specific Disks”](#) on page 128.

Alternatively, use the following command to dissociate and remove a mirror plex from a volume:

```
# vxplex -o rm dis plex
```

For example, to dissociate and remove a mirror named `vol01-02`, use the following command:

```
# vxplex -o rm dis vol01-02
```

This command removes the mirror `vol01-02` and all associated subdisks. This is equivalent to entering the following separate commands:

```
# vxplex dis vol01-02
# vxedit -r rm vol01-02
```

## Adding a DRL Log to a Mirrored Volume

To put dirty region logging (DRL) into effect for a mirrored volume, a log subdisk must be added to that volume. Only one log subdisk can exist per plex.

To add a DRL log to an existing volume, use the following command:

```
# vxassist addlog volume
```

For example, to create a log for the volume `vol03`, use the following command:

```
# vxassist addlog vol03
```

When the `vxassist` command is used to add a log subdisk to a volume, by default a log plex is also created to contain the log subdisk unless you include the keyword `nolog` in the layout specification.

For a volume that will be written to sequentially, such as a database log volume, include the `logtype=dr1seq` attribute to specify that sequential DRL is to be used:

```
# vxassist addlog volume logtype=dr1seq
```

Once created, the plex containing a log subdisk can be treated as a regular plex. Data subdisks can be added to the log plex. The log plex and log subdisk can be removed using the same procedures as are used to remove ordinary plexes and subdisks.

## Removing a DRL Log

To remove a DRL log, use the `vxassist` command as follows:

```
# vxassist remove log volume [nolog=n]
```

Use the optional attribute `nolog=n` to specify the number, *n*, of logs to be removed. By default, the `vxassist` command removes one log.



## Adding a RAID-5 Log

Only one RAID-5 plex can exist per RAID-5 volume. Any additional plexes become RAID-5 log plexes, which are used to log information about data and parity being written to the volume. When a RAID-5 volume is created using the `vxassist` command, a log plex is created for that volume by default.

To add a RAID-5 log to an existing volume, use the following command:

```
# vxassist addlog volume [loglen=length]
```

---

**Note** You can specify the log length used when adding the first log to a volume. Any logs that you add subsequently are configured with the same length as the existing log.

---

For example, to create a log for the RAID-5 volume `volraid`, use the following command:

```
# vxassist addlog volraid
```

## Adding a RAID-5 Log using vxplex

As an alternative to using `vxassist`, you can add a RAID-5 log using the `vxplex` command. For example, to attach a RAID-5 log plex, `r5log`, to a RAID-5 volume, `r5vol`, use the following command:

```
# vxplex att r5vol r5log
```

The attach operation can only proceed if the size of the new log is large enough to hold all of the data on the stripe. If the RAID-5 volume already contains logs, the new log length is the minimum of each individual log length. This is because the new log is a mirror of the old logs.

If the RAID-5 volume is not enabled, the new log is marked as `BADLOG` and is enabled when the volume is started. However, the contents of the log are ignored.

If the RAID-5 volume is enabled and has other enabled RAID-5 logs, the new log's contents are synchronized with the other logs.

If the RAID-5 volume currently has no enabled logs, the new log is zeroed before it is enabled.

## Removing a RAID-5 Log

To identify the plex of the RAID-5 log, use the following command:

```
# vxprint -ht volume
```

where *volume* is the name of the RAID-5 volume. For a RAID-5 log, the output lists a plex with a STATE field entry of LOG.

To dissociate and remove a RAID-5 log and any associated subdisks from an existing volume, use the following command:

```
# vxplex -o rm dis plex
```

For example, to disassociate and remove the log plex volraid-02 from volraid, use the following command:

```
# vxplex -o rm dis volraid-02
```

You can also remove a RAID-5 log with the vxassist command, as follows:

```
# vxassist remove log volume [nlog=n]
```

Use the optional attribute nlog=*n* to specify the number, *n*, of logs to be removed. By default, the vxassist command removes one log.

---

**Note** When removing the log leaves the volume with less than two valid logs, a warning is printed and the operation is not allowed to continue. The operation may be forced by additionally specifying the `-f` option to vxplex or vxassist.

---

## Resizing a Volume

Resizing a volume changes the volume size. For example, you might need to increase the length of a volume if it is no longer large enough for the amount of data to be stored on it. To resize a volume, use one of the commands: vxresize (preferred), vxassist, or vxvol.

---

**Note** You cannot use the procedures in this chapter to resize a volume or any underlying file system on an encapsulated root disk. This is because the underlying disk partitions also need to be reconfigured. If you really need to resize the volumes on the root disk, see the section “Recovering a root Disk” in the chapter “Recovery from Boot Disk Failure” in the *VERITAS Volume Manager Troubleshooting Guide*.

---

If a volume is increased in size, the vxassist command automatically locates available disk space. The vxresize command requires that you specify the names of the disks to be used to increase the size of a volume. The vxvol command requires that you have previously ensured that there is sufficient space available in the plexes of the volume to increase its size. The vxassist and vxresize commands automatically free unused space for use by the disk group. For the vxvol command, you must do this yourself. To find out by how much you can grow a volume, use the following command:

```
# vxassist maxgrow volume
```



When you resize a volume, you can specify the length of a new volume in sectors, kilobytes, megabytes, or gigabytes. The unit of measure is added as a suffix to the length (s, m, k, or g). If no unit is specified, sectors are assumed. The `vxassist` command also allows you to specify an increment by which to change the volume's size.

---

**Caution** If you use `vxassist` or `vxvol` to resize a volume, do not shrink it below the size of the file system which is located on it. If you do not shrink the file system first, you risk unrecoverable data loss. If you have a VxFS file system, shrink the file system first, and then shrink the volume. Other file systems may require you to back up your data so that you can later recreate the file system and restore its data.

---

## Resizing Volumes using `vxresize`

Use the `vxresize` command to resize a volume containing a file system. Although other commands can be used to resize volumes containing file systems, the `vxresize` command offers the advantage of automatically resizing certain types of file system as well as the volume.

See the following table for details of what operations are permitted and whether you must first unmount the file system to resize the file system:

Permitted Resizing Operations on File Systems

	VxFS	UFS
<b>Mounted File System</b>	Grow and shrink	Grow only
<b>Unmounted File System</b>	Not allowed	Grow only

For example, the following command resizes the 1-gigabyte volume, `homevol`, that contains a VxFS file system to 10 gigabytes using the spare disks `disk10` and `disk11`:

```
# vxresize -b -F vxfs -t homevolresize homevol 10g disk10 disk11
```

The `-b` option specifies that this operation runs in the background where its progress can be monitored by specifying the task tag `homevolresize` to the `vxtask` command.

For more information about the `vxresize` command, see the `vxresize(1M)` manual page.



## Resizing Volumes using `vxassist`

The following modifiers are used with the `vxassist` command to resize a volume:

- ◆ `growto`—increase volume to a specified length
- ◆ `growby`—increase volume by a specified amount
- ◆ `shrinkto`—reduce volume to a specified length
- ◆ `shrinkby`—reduce volume by a specified amount

---

**Caution** You cannot grow or shrink any volume associated with an encapsulated bootdisk (`rootvol`, `usr`, `var`, `opt`, `swapvol`, and so on) because these map to a physical underlying partition on the disk and must be contiguous. If you attempt to grow `rootvol`, `usrvol`, `varvol`, or `swapvol`, the system could become unbootable if you need to revert back to slices to boot. It can also prevent a successful Solaris upgrade and you might have to do a fresh install. Additionally, the `upgrade_start` script might fail.

---

### Extending to a Given Length

To extend a volume *to* a specific length, use the following command:

```
# vxassist growto volume length
```

For example, to extend `volcat` to 2000 sectors, use the following command:

```
# vxassist growto volcat 2000
```

### Extending by a Given Length

To extend a volume *by* a specific length, use the following command:

```
# vxassist growby volume length
```

For example, to extend `volcat` by 100 sectors, use the following command:

```
# vxassist growby volcat 100
```

### Shrinking to a Given Length

To shrink a volume *to* a specific length, use the following command:

```
# vxassist shrinkto volume length
```

For example, to shrink `volcat` to 1300 sectors, use the following command:

```
# vxassist shrinkto volcat 1300
```



**Caution** Do not shrink the volume below the current size of the file system or database using the volume. The `vxassist shrinkto` command can be safely used on empty volumes.

---

### Shrinking by a Given Length

To shrink a volume *by* a specific length, use the following command:

```
# vxassist shrinkby volume length
```

For example, to shrink `volcat` by 300 sectors, use the following command:

```
# vxassist shrinkby volcat 300
```

**Caution** Do not shrink the volume below the current size of the file system or database using the volume. The `vxassist shrinkby` command can be safely used on empty volumes.

---

## Resizing Volumes using vxvol

To change the length of a volume using the `vxvol set` command, use the following command:

```
# vxvol set len=length volume
```

For example, to change the length to 100000 sectors, use the following command:

```
# vxvol set len=100000 vol01
```

**Note** The `vxvol set len` command cannot increase the size of a volume unless the needed space is available in the plexes of the volume. When the size of a volume is reduced using the `vxvol set len` command, the freed space is not released into the disk group's free space pool.

---

If a volume is active and its length is being reduced, the operation must be forced using the `-o force` option to `vxvol`. This prevents accidental removal of space from applications using the volume.

The length of logs can also be changed using the following command:

```
# vxvol set loglen=length log_volume
```

**Note** Sparse log plexes are not valid. They must map the entire length of the log. If increasing the log length would make any of the logs invalid, the operation is not allowed. Also, if the volume is not active and is dirty (for example, if it has not been shut down cleanly), the log length cannot be changed. This avoids the loss of any of the log contents (if the log length is decreased), or the introduction of random data into the logs (if the log length is being increased).

---

## Changing the Read Policy for Mirrored Volumes

VxVM offers the choice of the following read policies on the data plexes in a mirrored volume:

- ◆ `round`—reads each plex in turn in “round-robin” fashion for each nonsequential I/O detected. Sequential access causes only one plex to be accessed. This takes advantage of the drive or controller read-ahead caching policies.
- ◆ `prefer`—reads first from a plex that has been named as the preferred plex.
- ◆ `select`—chooses a default policy based on plex associations to the volume. If the volume has an enabled striped plex, the `select` option defaults to preferring that plex; otherwise, it defaults to round-robin.

The read policy can be changed from `round` to `prefer` (or the reverse), or to a different preferred plex. The `vxvol rdpol` command sets the read policy for a volume.

---

**Note** You cannot set the read policy on a RAID-5 volume. RAID-5 plexes have their own read policy (RAID).

---

To set the read policy to `round`, use the following command:

```
# vxvol rdpol round volume
```

For example, to set the read policy for volume `vol01` to a round-robin read, use the following command:

```
# vxvol rdpol round vol01
```

To set the read policy to `prefer`, use the following command:

```
# vxvol rdpol prefer volume preferred_plex
```

For example, to set the policy for `vol01` to read preferentially from the plex `vol01-02`, use the following command:

```
# vxvol rdpol prefer vol01 vol01-02
```



To set the read policy to `select`, use the following command:

```
# vxvol rdpol select volume
```

For more information about how read policies affect performance, see “[Volume Read Policies](#)” on page 221.

## Removing a Volume

Once a volume is no longer necessary (it is inactive and its contents have been archived, for example), it is possible to remove the volume and free up the disk space for other uses.

Before removing a volume, use the following procedure to stop all activity on the volume:

1. Remove all references to the volume by application programs, including shells, that are running on the system.
2. If the volume is mounted as a file system, unmount it with this command:  

```
# umount /dev/vx/dsk/volume
```
3. If the volume is listed in the `/etc/vfstab` file, remove its entry by editing this file. Refer to your operating system documentation for more information about the format of this file and how you can modify it.
4. Stop all activity by VxVM on the volume with the command:  

```
# vxvol stop volume
```

After following these steps, remove the volume with the `vxassist` command:

```
# vxassist remove volume volume
```

Alternatively, you can use the `vxedit` command to remove a volume:

```
# vxedit [-r] [-f] rm volume
```

The `-r` option to `vxedit` indicates recursive removal. This removes all plexes associated with the volume and all subdisks associated with those plexes. The `-f` option to `vxedit` forces removal. This is necessary if the volume is still enabled.

## Moving Volumes from a VM Disk

Before you disable or remove a disk, you can move the data from that disk to other disks on the system. To do this, ensure that the target disks have sufficient space, and then use the following procedure:

1. Select menu item 7 (Move volumes from a disk) from the `vxdiskadm` main menu.
2. At the following prompt, enter the disk name of the disk whose volumes you wish to move, as follows:

```
Move volumes from a disk
Menu: VolumeManager/Disk/Evacuate
Use this menu operation to move any volumes that are using a
disk onto other disks. Use this menu immediately prior to
removing a disk, either permanently or for replacement. You can
specify a list of disks to move volumes onto, or you can move
the volumes to any available disk space in the same disk group.
```

NOTE: Simply moving volumes off of a disk, without also removing the disk, does not prevent volumes from being moved onto the disk by future operations. For example, using two consecutive move operations may move volumes from the second disk to the first.

```
Enter disk name [<disk>,list,q,?] disk01
```

After the following display, you can optionally specify a list of disks to which the volume(s) should be moved.

```
You can now specify a list of disks to move onto. Specify a
list of disk media names (e.g., disk01) all on one line
separated by blanks. If you do not enter any disk media names,
then the volumes will be moved to any available space in the
disk group.
```

At the following prompt, press Return to move the volumes:

```
Requested operation is to move all volumes from disk disk01 in
group rootdg.
```

NOTE: This operation can take a long time to complete.

```
Continue with operation? [y,n,q,?] (default: y)
```

As the volumes are moved from the disk, the `vxdiskadm` program displays the status of the operation:



```
Move volume voltest ...
Move volume voltest-bk00 ...
```

When the volumes have all been moved, the `vxdiskadm` program displays the following success message:

```
Evacuation of disk disk01 is complete.
```

3. At the following prompt, indicate whether you want to move volumes from another disk (**y**) or return to the `vxdiskadm` main menu (**n**):

```
Move volumes from another disk? [y,n,q,?] (default: n)
```

## Enabling FastResync on a Volume

FastResync (FR) performs quick and efficient resynchronization of stale mirrors. It also increases the efficiency of the VxVM snapshot mechanism when used with operations such as backup and decision support. See [“Backing Up Volumes Online Using Snapshots”](#) on page 159 and [“FastResync \(FR\) and Snapshots”](#) on page 37 for more information.

---

**Note** FastResync is not supported for RAID-5 volumes.

---

When creating a new volume with `vxassist`, you can turn FastResync on or off for the volume by specifying either of the keywords `fmr` or `fastresync`.

To create a volume with FastResync enabled, specify the `fastresync=on` attribute to the `vxassist make` command, for example:

```
# vxassist make volume length layout=layout fastresync=on
```

By default, FastResync is turned `off`, but you can change this by editing the `vxassist` default file (see [“Setting Default Values for vxassist”](#) on page 125).

You can also use the `vxvol` command to turn on FastResync functionality for an existing volume:

```
# vxvol set fastresync=on volume
```

To use FastResync with a snapshot, it must be enabled before the snapshot is taken, and it must remain enabled until after the snapback is completed, or until the snapshot volume is removed.

## Disabling FastResync

To turn off FastResync when creating a volume, use the following command:

```
# vxassist make volume length fastresync=off
```

You can also use the `vxvol` command to turn off FastResync for an existing volume:

```
# vxvol set fastresync=off volume
```

Turning FastResync off releases all tracking maps for the specified volume. All subsequent reattaches will not use the FastResync facility, but perform a full resynchronization of the volume. This occurs even if FastResync is later turned on.

## Backing up Volumes Online

It is important to make backup copies of your volumes. These provide replicas of the data as it existed at the time of the backup. Backup copies are used to restore volumes lost due to disk failure, or data destroyed due to human error. VxVM allows you to back up volumes online with minimal interruption to users.

Two methods of backing up volumes online are described in the following sections: “[Backing Up Volumes Online Using Mirrors](#)” and “[Backing Up Volumes Online Using Snapshots](#)” on page 159.

## Backing Up Volumes Online Using Mirrors

---

**Note** The procedure described in this section cannot be applied to RAID-5 volumes.

---

If a volume is mirrored, backup can be done on that volume by taking one of the data plaxes offline for a period of time. This removes the need for extra disk space for the purpose of backup only. However, if the volume only has two data plaxes, it also removes redundancy of the volume for the duration of the time needed for the backup to take place.

You can perform backup of a mirrored volume on an active system with these steps:

1. Dissociate one of the volume’s data plaxes (`vol01-01`, for example) using the following command:

```
# vxplex dis plex
```

Optionally, stop user activity during this time to improve the consistency of the backup.



2. Create a temporary volume, *tempvol*, that uses the dissociated plex, using the following command:

```
# vxmake -U gen vol tempvol plex=plex
```

3. Start the temporary volume, using the following command:

```
# vxvol start tempvol
```

4. Use `fsck` (or some utility appropriate for the application running on the volume) to clean the temporary volume's contents. For example, you can use this command:

```
# fsck -y /dev/vx/rdisk/tempvol
```

5. Perform appropriate backup procedures, using the temporary volume.

6. Stop the temporary volume, using the following command:

```
# vxvol stop tempvol
```

7. Dissociate the backup plex from its temporary volume, using the following command:

```
# vxplex dis plex
```

8. Reassociate the backup plex with its original volume to regain redundancy of the volume, using the following command:

```
# vxplex att original_volume plex
```

9. Remove the temporary volume, using the following command:

```
# vxedit rm tempvol
```

---

**Note** If the file system is active during the period that the temporary volume is created, its contents may be inconsistent. For information on an alternative online backup method using the VxVM snapshot facility, see the next section “[Backing Up Volumes Online Using Snapshots.](#)”

---



## Backing Up Volumes Online Using Snapshots

**Note** You can use the procedure described in this section to create a snapshot of a RAID-5 volume and to back it up.

VxVM provides snapshot images of volume devices using `vxassist` and other commands. If the `fsgen` volume usage type is set on a volume that contains a VERITAS File System (VxFS), the snapshot mechanism ensures the internal consistency of the file system that is backed up. For `ufs` and `s5` file system types, there may be inconsistencies between in-memory data and the data in the snapshot image.

There are various procedures for doing backups, depending upon the requirements for integrity of the volume contents. These procedures have the same starting requirement: a plex that is large enough to store the complete contents of the volume. The plex can be larger than necessary, but if a plex that is too small is used, an incomplete copy results.

The recommended approach to performing volume backup from the command line, or from a script, is to use the `vxassist` command. The `vxassist snapstart`, `snapwait`, and `snapshot` tasks allow you to back up volumes online with minimal disruption to users.

The `vxassist snapshot` procedure consists of two steps:

1. Running `vxassist snapstart` to create a snapshot mirror
2. Running `vxassist snapshot` to create a snapshot volume

The `vxassist snapstart` step creates a write-only backup plex which gets attached to and synchronized with the volume. When synchronized with the volume, the backup plex is ready to be used as a snapshot mirror. The end of the update procedure is indicated by the new snapshot mirror changing its state to `SNAPDONE`. This change can be tracked by the `vxassist snapwait` task, which waits until at least one of the mirrors changes its state to `SNAPDONE`. If the attach process fails, the snapshot mirror is removed and its space is released.

Once the snapshot mirror is synchronized, it continues being updated until it is detached. You can then select a convenient time at which to create a snapshot volume as an image of the existing volume. You can also ask users to refrain from using the system during the brief time required to perform the `snapshot` (typically less than a minute). The amount of time involved in creating the snapshot mirror is long in contrast to the brief amount of time that it takes to create the snapshot volume.

The online backup procedure is completed by running the `vxassist snapshot` command on a volume with a `SNAPDONE` mirror. This task detaches the finished snapshot (which becomes a normal mirror), creates a new normal volume and attaches the snapshot mirror to the snapshot volume. The snapshot then becomes a normal, functioning mirror and the state of the snapshot is set to `ACTIVE`.



If the snapshot procedure is interrupted, the snapshot mirror is automatically removed when the volume is started.

To back up a volume with the `vxassist` command, use the following procedure:

1. Create a snapshot mirror for a volume using the following command:

```
# vxassist [-b] snapstart volume
```

For example, to create a snapshot mirror of a volume called `voldef`, use the following command:

```
# vxassist snapstart voldef
```

The `vxassist snapstart` task creates a write-only backup mirror, which is attached to and synchronized with the volume to be backed up.

If you start `vxassist snapstart` in the background using the `-b` option, you can use the `vxassist snapwait` command to wait for the creation of the mirror to complete as shown here:

```
# vxassist snapwait volume
```

If `vxassist snapstart` is not run in the background, it does not exit until the backup mirror is ready. When synchronized with the volume, the backup mirror is ready to be used as a snapshot mirror. However, it continues being updated until you take the snapshot.

2. Choose a suitable time to create a snapshot. If possible, plan to take the snapshot at a time when users are accessing the volume as little as possible.
3. Create a snapshot volume using the following command:

```
# vxassist snapshot volume snapshot
```

For example, to create a snapshot of `voldef`, use the following command:

```
# vxassist snapshot voldef snapvol
```

The `vxassist snapshot` task detaches the finished snapshot mirror, creates a new volume, and attaches the snapshot mirror to it as a read-only volume. This step should only take a few minutes. The snapshot volume, which reflects the original volume at the time of the snapshot is now available for backing up, while the original volume continues to be available for applications and users.

4. Use `fsck` (or some utility appropriate for the application running on the volume) to clean the temporary volume's contents. For example, you can use this command:

```
# fsck -y /dev/vx/rdisk/snapshot
```

5. Use a backup utility or operating system command to copy the temporary volume to tape, or to some other appropriate backup media.

The snapshot volume occupies as much space as the original volume. To avoid wasting space, remove the snapshot volume when your backup is complete. Remove the new volume with this command:

```
# vxedit -rf rm snapshot
```

Alternatively, you can merge the snapshot copy with the original volume (provided it was not a RAID-5 volume) as described in the section, “[Merging a Snapshot Volume \(snapback\)](#)” on page 161, or dissociate it entirely from the original volume as described in “[Dissociating a Snapshot Volume](#)” on page 162.

## Backing Up Multiple Volumes Using Snapshots

To make it easier to create snapshots of several volumes at the same time, the snapshot option accepts more than one volume name as its argument, for example:

```
# vxassist snapshot volume1 volume2 ...
```

By default, each replica volume is named `SNAPnumber-volume`, where `number` is a unique serial number, and `volume` is the name of the volume being snapshot. This default pattern can be overridden by using the option `-o name=pattern`, as described on the `vxassist(1M)` manual page. For example, the pattern `SNAP%v-%d` reverses the order of the `number` and `volume` components in the name.

To snapshot all the volumes in a single disk group, specify the option `-o allvols` to `vxassist`:

```
# vxassist -g diskgroup -o allvols snapshot
```

However, this operation fails if any of the volumes in the disk group do not have a complete snapshot plex.

## Merging a Snapshot Volume (snapback)

---

**Note** The information in this section does not apply to RAID-5 volumes.

---

*Snapback* merges a snapshot copy of a volume with the original volume. The snapshot plex is detached from the snapshot volume and attached to the original volume. The snapshot volume is then removed. This task resynchronizes the data in the volume so that the plexes are consistent.



**Note** To enhance the efficiency of the snapback operation for mirrored volumes, enable FastResync on the volume before taking the snapshot, as described in “[Enabling FastResync on a Volume](#)” on page 156.

---

To merge a snapshot with its original volume, use the following command:

```
# vxassist snapback snapshot
```

where *replica-volume* is the snapshot copy of the volume.

By default, the data in the original plex is used to update the merged volume. To copy the data from the replica volume instead, use the following command:

```
# vxassist -o resyncfromreplica snapback snapshot
```

**Caution** Unmount the file system corresponding to the primary volume before using the `resyncfromreplica` option.

---

## Dissociating a Snapshot Volume

The link between a snapshot and its original volume can be permanently broken so that the snapshot volume becomes an independent volume.

To dissociate a snapshot from its original volume, use the following command:

```
# vxassist snapclear snapshot
```

where *snapshot* is the snapshot copy of the volume.

## Displaying Snapshot Information

The `vxassist snapprint` command displays the associations between the original volumes and their respective replicas (snapshot copies):

```
# vxassist snapprint [volume]
```

The output from this command is similar to the following:

```
V NAME   USETYPE  LENGTH
RP NAME   VOLUME   LENGTH   RRPLEXID
v vol    fsgen    2048
rp vol-05 SNAP1-vol 3040     rp vol-04
```

If a volume is specified, the `snapprint` command displays an error message if no FastResync maps are enabled for that volume.

## Performing Online Relayout

---

**Note** VxVM supports this feature for private disk groups, but not for shareable disk groups in a cluster environment.

---

You can use the `vxassist relayout` command to reconfigure the layout of a volume without taking it offline. The general form of this command is:

```
# vxassist [-g diskgroup] relayout volume [layout=layout] \  
  [relayout_options]
```

The following are valid destination layout configurations as determined by the tables in “[Permitted Transformations](#)” on page 30:

```
concat-mirror—concatenated-mirror  
raid5—RAID-5  
span,nostripe,nomirror—concatenated  
stripe—striped  
stripe-mirror—striped-mirror
```

For example, the following command changes a concatenated volume to a striped volume with the default number of columns, 2, and stripe unit size, 64k:

```
# vxassist relayout vol02 layout=stripe
```

On occasions, it may be necessary to perform a relayout on a plex rather than on a volume. See “[Specifying a Plex for Relayout](#)” on page 164 for more information.

## Specifying a Non-Default Layout

You can specify one or more relayout options to change the default layout configuration. Examples of these options are:

```
ncol=number—specifies the number of columns  
ncol=+number—specifies the number of columns to add  
ncol=-number—specifies the number of columns to remove  
stripeunit=size—specifies the stripe width
```

See the `vxassist(1M)` manual page for more information about relayout options.

The following are some examples of using `vxassist` to change the stripe width and number of columns for a striped volume in the disk group `dbaseg`:



```
# vxassist -g dbaseg relayout vol03 stripeunit=64k ncol=6
# vxassist -g dbaseg relayout vol03 ncol=+2
# vxassist -g dbaseg relayout vol03 stripeunit=128k
```

The next example changes a concatenated volume to a RAID-5 volume with four columns:

```
# vxassist -g fsgrp relayout vol04 layout=raid5 ncol=4
```

## Specifying a Plex for Relayout

Any layout can be changed to RAID-5 if there are sufficient disks and space in the disk group. If you convert a mirrored volume to RAID-5, you must specify which plex is to be converted. All other plexes are removed when the conversion has finished, releasing their space for other purposes. If you convert a mirrored volume to a layout other than RAID-5, the unconverted plexes are not removed. You can specify the plex to be converted by naming it in place of a volume:

```
# vxassist relayout plex [layout=layout] [relayout_options]
```

## Tagging a Relayout Operation

If you want to control the progress of a relayout operation, for example to pause or reverse it, use the `-t` option to `vxassist` to specify a task tag that will be associated with the operation. For example, this relayout is associated with the tag `myconv`:

```
# vxassist -g fsgrp -t myconv relayout vol04 layout=raid5 ncol=4
```

See the following sections, “[Viewing the Status of a Relayout](#)” and “[Controlling the Progress of a Relayout](#),” for more information about tracking and controlling the progress of relayout.

## Viewing the Status of a Relayout

Online relayout operations take some time to perform. You can use the `vxrelayout` command to obtain information about the status of a relayout operation. For example, the command:

```
# vxrelayout status vol04
```

might display output similar to this:

```
STRIPED, columns=5, stwidth=128--> STRIPED, columns=6, stwidth=128
Relayout running, 68.58% completed.
```

In this example, the reconfiguration of a striped volume from 5 to 6 columns is in progress, and is just over two-thirds complete.

See the `vxrelayout(1M)` manual page for more information about this command.

If you specified a task tag to `vxassist` when you started the relayout, you can use this tag with the `vxtask` command to monitor the progress of the relayout. For example, to monitor the task tagged as `myconv`, enter:

```
# vxtask monitor myconv
```

## Controlling the Progress of a Relayout

You can use the `vxtask` command to stop (pause) the relayout temporarily, or to cancel it altogether (abort). If you specified a task tag to `vxassist` when you started the relayout, you can use this tag to specify the task to `vxtask`. For example, to pause the relayout operation tagged as `myconv`, enter:

```
# vxtask pause myconv
```

To resume the operation, use the `vxtask` command:

```
# vxtask resume myconv
```

or specify the `start` keyword to `vxrelayout`, as shown here:

```
# vxrelayout -o bg start vol04
```

The `-o bg` option restarts the relayout in the background. You can also specify the `slow` and `iosize` option modifiers to control the speed of the relayout and the size of each region that is copied. For example, the following command inserts a delay of 1000 milliseconds (1 second) between copying each 64-kilobyte region:

```
# vxrelayout -o bg,slow=1000,iosize=64 start vol04
```

The default delay and region size values are 250 milliseconds and 32 kilobytes respectively.

To reverse the direction of relayout operation that is currently paused, specify the `reverse` keyword to `vxrelayout` as shown in this example:

```
# vxrelayout -o bg reverse vol04
```

This undoes changes made to the volume so far, and returns it to its original layout.

If you cancel the relayout using `vxtask abort`, the direction of the conversion is also reversed, and the volume is returned to its original configuration.

See the `vxrelayout(1M)` and `vxtask(1M)` manual pages for more information about these commands. See [“Managing Tasks with vxtask”](#) on page 141 for more information about controlling tasks in VxVM.



## Converting Between Layered and Non-Layered Volumes

---

**Note** VxVM supports this feature for private disk groups, but not for shareable disk groups in a cluster environment.

---

The `vxassist convert` command transforms volume layouts between layered and non-layered forms:

```
# vxassist convert volume [layout=layout] [convert_options]
```

The following conversion layouts are supported:

stripe-mirror—mirrored-stripe to striped-mirror

mirror-stripe—striped-mirror to mirrored-stripe

concat-mirror—mirrored-concatenated to concatenated-mirror

mirror-concat—concatenated-mirror to mirrored-concatenated

Volume conversion can be used before or after performing online relayout to achieve a larger number of transformations than would otherwise be possible. During relayout process, a volume may also be converted into a layout that is intermediate to the one that is desired. For example, to convert a volume from a 4-column mirrored-stripe to a 5-column mirrored-stripe, first use `vxassist relayout` to convert the volume to a 5-column striped-mirror:

```
# vxassist relayout vol1 ncol=5
```

When the relayout has completed, use the `vxassist convert` command to change the resulting layered striped-mirror volume to a non-layered mirrored-stripe:

```
# vxassist convert vol1 layout=mirror-stripe
```

---

**Note** If the system crashes during relayout or conversion, the process continues when the system is rebooted. However, if the crash occurred during the first stage of a two-stage relayout and convert operation, only the first stage will be completed. You must run `vxassist convert` manually to complete the operation.

---



## Introduction

If a volume has a disk I/O failure (for example, because the disk has an uncorrectable error), VERITAS Volume Manager (VxVM) can detach the plex involved in the failure. I/O stops on that plex but continues on the remaining plexes of the volume.

If a disk fails completely, VxVM can detach the disk from its disk group. All plexes on the disk are disabled. If there are any unmirrored volumes on a disk when it is detached, those volumes are also disabled.

---

**Note** Apparent disk failure may not be due to a fault in the physical disk media or the disk controller, but may instead be caused by a fault in an intermediate or ancillary component such as a cable, host bus adapter, or power supply.

---

The hot-relocation feature in VxVM automatically detects disk failures, and notifies the system administrator and other nominated users of the failures by electronic mail. Hot-relocation also attempts to use spare disks and free disk space to restore redundancy and to preserve access to mirrored and RAID-5 volumes. For more information, see the following section, “[How Hot-Relocation works.](#)”

If hot-relocation is disabled or you miss the electronic mail, you can use the `vxprint` command or the graphical user interface to examine the status of the disks. You may also see driver error messages on the console or in the system messages file.

Failed disks must be removed and replaced manually as described in “[Removing and Replacing Disks](#)” on page 63.

For more information about recovering volumes and their data after hardware failure, see the *VERITAS Volume Manager Troubleshooting Guide*.



## How Hot-Relocation works

Hot-relocation allows a system to react automatically to I/O failures on redundant (mirrored or RAID-5) VxVM objects, and to restore redundancy and access to those objects. VxVM detects I/O failures on objects and relocates the affected subdisks to disks designated as spare disks or to free space within the disk group. VxVM then reconstructs the objects that existed before the failure and makes them redundant and accessible again.

When a partial disk failure occurs (that is, a failure affecting only some subdisks on a disk), redundant data on the failed portion of the disk is relocated. Existing volumes on the unaffected portions of the disk remain accessible.

---

**Note** Hot-relocation is only performed for redundant (mirrored or RAID-5) subdisks on a failed disk. Non-redundant subdisks on a failed disk are not relocated, but the system administrator is notified of their failure.

---

Hot-relocation is enabled by default and takes effect without the intervention of the system administrator when a failure occurs. The hot-relocation daemon, `vxrelocd`, detects and reacts to VxVM events that signify the following types of failures:

- ◆ disk failure—this is normally detected as a result of an I/O failure from a VxVM object. VxVM attempts to correct the error. If the error cannot be corrected, VxVM tries to access configuration information in the private region of the disk. If it cannot access the private region, it considers the disk failed.
- ◆ plex failure—this is normally detected as a result of an uncorrectable I/O error in the plex (which affects subdisks within the plex). For mirrored volumes, the plex is detached.
- ◆ RAID-5 subdisk failure—this is normally detected as a result of an uncorrectable I/O error. The subdisk is detached.

When `vxrelocd` detects such a failure, it performs the following steps:

1. `vxrelocd` informs the system administrator (and other nominated users, see [“Modifying the Behavior of Hot-Relocation”](#) on page 181) by electronic mail of the failure and which VxVM objects are affected. See [“Partial Disk Failure Mail Messages”](#) on page 169 and [“Complete Disk Failure Mail Messages”](#) on page 170 for more information.
2. `vxrelocd` next determines if any subdisks can be relocated. `vxrelocd` looks for suitable space on disks that have been reserved as hot-relocation spares (marked `spare`) in the disk group where the failure occurred. It then relocates the subdisks to use this space.

3. If no spare disks are available or additional space is needed, `vxrelocd` uses free space on disks in the same disk group, except those disks that have been excluded for hot-relocation use (marked `nohotuse`). When `vxrelocd` has relocated the subdisks, it reattaches each relocated subdisk to its plex.
4. Finally, `vxrelocd` initiates appropriate recovery procedures. For example, recovery includes mirror resynchronization for mirrored volumes or data recovery for RAID-5 volumes. It also notifies the system administrator of the hot-relocation and recovery actions that have been taken.

If relocation is not possible, `vxrelocd` notifies the system administrator and takes no further action.

---

**Note** Hot-relocation does not guarantee the same layout of data or the same performance after relocation. The system administrator can make configuration changes after hot-relocation occurs.

---

Relocation of failing subdisks is not possible in the following cases:

- ◆ The failing subdisks are on non-redundant volumes (that is, volumes of types other than mirrored or RAID-5).
- ◆ There are insufficient spare disks or free disk space in the disk group.
- ◆ The only available space is on a disk that already contains a mirror of the failing plex.
- ◆ The only available space is on a disk that already contains the RAID-5 log plex or one of its healthy subdisks, failing subdisks in the RAID-5 plex cannot be relocated.
- ◆ If a mirrored volume has a dirty region logging (DRL) log subdisk as part of its data plex, failing subdisks belonging to that plex cannot be relocated.
- ◆ If a RAID-5 volume log plex or a mirrored volume DRL log plex fails, a new log plex is created elsewhere. There is no need to relocate the failed subdisks of log plex.

See the `vxrelocd(1M)` manual page for more information about the hot-relocation daemon.

## Partial Disk Failure Mail Messages

If hot-relocation is enabled when a plex or disk is detached by a failure, mail indicating the failed objects is sent to `root`. If a partial disk failure occurs, the mail identifies the failed plexes. For example, if a disk containing mirrored volumes fails, you can receive mail information as shown in the following example:



```
To: root
Subject: Volume Manager failures on host teal

Failures have been detected by the VERITAS Volume Manager:

failed plexes:
  home-02
  src-02
```

See [“Modifying the Behavior of Hot-Relocation”](#) on page 181 for information on how to send the mail to users other than `root`.

You can determine which disk is causing the failures in the above example message by using the following command:

```
# vxstat -s -ff home-02 src-02
```

The `-s` option asks for information about individual subdisks, and the `-ff` option displays the number of failed read and write operations. The following output display is typical:

TYP NAME	FAILED	
	READS	WRITES
sd disk01-04	0	0
sd disk01-06	0	0
sd disk02-03	1	0
sd disk02-04	1	0

This example shows failures on reading from subdisks `disk02-03` and `disk02-04` of `disk02`.

Hot-relocation automatically relocates the affected subdisks and initiates any necessary recovery procedures. However, if relocation is not possible or the hot-relocation feature is disabled, you must investigate the problem and attempt to recover the plexes. Errors can be caused by cabling failures, so check the cables connecting your disks to your system. If there are obvious problems, correct them and recover the plexes using the following command:

```
# vxrecover -b home src
```

This starts recovery of the failed plexes in the background (the command prompt reappears before the operation completes). If an error message appears later, or if the plexes become detached again and there are no obvious cabling failures, replace the disk (see [“Removing and Replacing Disks”](#) on page 63).

## Complete Disk Failure Mail Messages

If a disk fails completely and hot-relocation is enabled, the mail message lists the disk that failed and all plexes that use the disk. For example, you can receive mail as shown in this example display:

```
To: root
Subject: Volume Manager failures on host teal

Failures have been detected by the VERITAS Volume Manager:

failed disks:
  disk02

failed plexes:
  home-02
  src-02
  mkting-01

failing disks:
  disk02
```

This message shows that `disk02` was detached by a failure. When a disk is detached, I/O cannot get to that disk. The plexes `home-02`, `src-02`, and `mkting-01` were also detached (probably because of the failure of the disk).

As described in [“Partial Disk Failure Mail Messages”](#) on page 169, the problem can be a cabling error. If the problem is not a cabling error, replace the disk (see [“Removing and Replacing Disks”](#) on page 63).

## How Space is Chosen for Relocation

A spare disk must be initialized and placed in a disk group as a spare before it can be used for replacement purposes. If no disks have been designated as spares when a failure occurs, VxVM automatically uses any available free space in the disk group in which the failure occurs. If there is not enough spare disk space, a combination of spare space and free space is used.

The free space used in hot-relocation must not have been excluded from hot-relocation use. Disks can be excluded from hot-relocation use by using `vxdiskadm`, `vxedit` or the Storage Administrator.

You can designate one or more disks as hot-relocation spares within each disk group. Disks can be designated as spares by using `vxdiskadm`, `vxedit`, or the Storage Administrator. Disks designated as spares do not participate in the free space model and should not have storage space allocated on them.

When selecting space for relocation, hot-relocation preserves the redundancy characteristics of the VxVM object to which the relocated subdisk belongs. For example, hot-relocation ensures that subdisks from a failed plex are not relocated to a disk containing a mirror of the failed plex. If redundancy cannot be preserved using any available spare disks and/or free space, hot-relocation does not take place. If relocation is not possible, the system administrator is notified and no further action is taken.



From the eligible disks, hot-relocation attempts to use the disk that is “closest” to the failed disk. The value of “closeness” depends on the controller, target, and disk number of the failed disk. A disk on the same controller as the failed disk is closer than a disk on a different controller. A disk under the same target as the failed disk is closer than one on a different target.

Hot-relocation tries to move all subdisks from a failing drive to the same destination disk, if possible.

If the failing disk is a root disk, hot-relocation only works if it can relocate all of the file systems to the same disk. If none are found, the system administrator is notified through email.

When hot-relocation takes place, the failed subdisk is removed from the configuration database, and VxVM ensures that the disk space used by the failed subdisk is not recycled as free space.

## Configuring a System for Hot-Relocation

By designating spare disks and making free space on disks available for use by hot relocation, you can control how disk space is used for relocating subdisks in the event of a disk failure. If the combined free space and space on spare disks is not sufficient or does not meet the redundancy constraints, the subdisks are not relocated.

- ◆ To find out which disks are spares or are excluded from hot-relocation, see [“Displaying Spare Disk Information”](#) on page 173.

You can prepare for hot-relocation by designating one or more disks per disk group as hot-relocation spares.

- ◆ To designate a disk as being a hot-relocation spare for a disk group, see [“Marking a Disk as a Hot-Relocation Spare”](#) on page 173.
- ◆ To remove a disk from use as a hot-relocation spare, see [“Removing a Disk from Use as a Hot-Relocation Spare”](#) on page 174.

If no spares are available at the time of a failure or if there is not enough space on the spares, free space on disks in the same disk group as where the failure occurred is automatically used, unless it has been excluded from hot-relocation use.

- ◆ To exclude a disk from hot-relocation use, see [“Excluding a Disk from Hot-Relocation Use”](#) on page 175.
- ◆ To make a disk available for hot-relocation use, see [“Making a Disk Available for Hot-Relocation Use”](#) on page 175.

Depending on the locations of the relocated subdisks, you can choose to move them elsewhere after hot-relocation occurs (see [“Moving and Unrelocating Subdisks”](#) on page 176).

After a successful relocation, remove and replace the failed disk as described in “[Removing and Replacing Disks](#)” on page 63).

## Displaying Spare Disk Information

Use the following command to display information about spare disks that are available for relocation:

```
# vxdg spare
```

The following is example output:

GROUP	DISK	DEVICE	TAG	OFFSET	LENGTH	FLAGS
rootdg	disk02	c0t2d0s2	c0t2d0	0	658007	s

Here `disk02` is the only disk designated as a spare. The `LENGTH` field indicates how much spare space is currently available on `disk02` for relocation.

The following commands can also be used to display information about disks that are currently designated as spares:

- ◆ `vxdisk list` lists disk information and displays spare disks with a `spare` flag.
- ◆ `vxprint` lists disk and other information and displays spare disks with a `SPARE` flag.
- ◆ The `list` menu item on the `vxdiskadm` main menu lists spare disks.

## Marking a Disk as a Hot-Relocation Spare

---

**Note** You may need an additional license to use this feature.

---

Hot-relocation allows the system to react automatically to I/O failure by relocating redundant subdisks to other disks. Hot-relocation then restores the affected VxVM objects and data. If a disk has already been designated as a spare in the disk group, the subdisks from the failed disk are relocated to the spare disk. Otherwise, any suitable free space in the disk group is used except for the free space on the disks that were previously excluded from hot-relocation use.

To designate a disk as a hot-relocation spare, enter the following command:

```
# vxedit set spare=on diskname
```

For example, to designate `disk01` as a spare, enter the following command:

```
# vxedit set spare=on disk01
```

You can use the `vxdisk list` command to confirm that this disk is now a spare; `disk01` should be listed with a `spare` flag.



Any VM disk in this disk group can now use this disk as a spare in the event of a failure. If a disk fails, hot-relocation automatically occurs (if possible). You are notified of the failure and relocation through electronic mail. After successful relocation, you may want to replace the failed disk.

Alternatively, you can use `vxdiskadm` to designate a disk as a hot-relocation spare:

1. Select menu item 12 (Mark a disk as a spare for a disk group) from the `vxdiskadm` main menu.

2. At the following prompt, enter a disk name (such as `disk01`):

```
Menu: VolumeManager/Disk/MarkSpareDisk
```

```
Use this operation to mark a disk as a spare for a disk group.
```

```
This operation takes, as input, a disk name. This is the same name that you gave to the disk when you added the disk to the disk group.
```

```
Enter disk name [<disk>,list,q,?] disk01
```

3. At the following prompt, indicate whether you want to add more disks as spares (y) or return to the `vxdiskadm` main menu (n):

```
Mark another disk as a spare? [y,n,q,?] (default: n)
```

Any VM disk in this disk group can now use this disk as a spare in the event of a failure. If a disk fails, hot-relocation should automatically occur (if possible). You should be notified of the failure and relocation through electronic mail. After successful relocation, you may want to replace the failed disk.

## Removing a Disk from Use as a Hot-Relocation Spare

---

**Note** You may need an additional license to use this feature.

---

While a disk is designated as a spare, the space on that disk is not used for the creation of VxVM objects within its disk group. If necessary, you can free a spare disk for general use by removing it from the pool of hot-relocation disks.

To remove a spare from the hot-relocation pool, use the following command:

```
# vxedit set spare=off diskname
```

For example, to make `disk01` available for normal use, use the following command:

```
# vxedit set spare=off disk01
```



## Excluding a Disk from Hot-Relocation Use

---

**Note** You may need an additional license to use this feature.

---

To exclude a disk from hot-relocation use, use the following command:

```
# vxedit -g disk_group set nohotuse=on diskname
```

Alternatively, using `vxdiskadm`:

1. Select menu item 15 (Exclude a disk from hot-relocation use) from the `vxdiskadm` main menu.
2. At the following prompt, enter the disk name (such as `disk01`):

```
Exclude a disk from hot-relocation use
Menu: VolumeManager/Disk/UnmarkSpareDisk
```

```
Use this operation to exclude a disk from hot-relocation use.
This operation takes, as input, a disk name. This is the same
name that you gave to the disk when you added the disk to the
disk group.
```

```
Enter disk name [<disk>,list,q,?] disk01
```

The `vxdiskadm` program displays the following confirmation:

```
Excluding disk01 in rootdg from hot-relocation use is complete.
```

3. At the following prompt, indicate whether you want to add more disks to be excluded from hot-relocation (**y**) or return to the `vxdiskadm` main menu (**n**):

```
Exclude another disk from hot-relocation use? [y,n,q,?]
(default: n)
```

## Making a Disk Available for Hot-Relocation Use

---

**Note** You may need an additional license to use this feature.

---

Free space is used automatically by hot-relocation in case spare space is not sufficient to relocate failed subdisks. You can limit this free space usage by hot-relocation by specifying which free disks should not be touched by hot-relocation. If a disk was previously excluded from hot-relocation use, you can undo the exclusion and add the disk back to the hot-relocation pool.



To make a disk available for hot-relocation use, use the following command:

```
# vxedit -g disk_group set nohotuse=off diskname
```

Alternatively, using `vxdiskadm`:

1. Select menu item 16 (Make a disk available for hot-relocation use) from the `vxdiskadm` main menu.
2. At the following prompt, enter the disk name (such as `disk01`):

```
Menu: VolumeManager/Disk/UnmarkSpareDisk
```

```
Use this operation to make a disk available for hot-relocation use. This only applies to disks that were previously excluded from hot-relocation use. This operation takes, as input, a disk name. This is the same name that you gave to the disk when you added the disk to the disk group.
```

```
Enter disk name [<disk>,list,q,?] disk01
```

The `vxdiskadm` program displays the following confirmation:

```
Making disk01 in rootdg available for hot-relocation use is complete.
```

3. At the following prompt, indicate whether you want to add more disks to be excluded from hot-relocation (**y**) or return to the `vxdiskadm` main menu (**n**):

```
Make another disk available for hot-relocation use? [y,n,q,?]  
(default: n)
```

## Moving and Unrelocating Subdisks

When hot-relocation occurs, subdisks are relocated to spare disks and/or available free space within the disk group. The new subdisk locations may not provide the same performance or data layout that existed before hot-relocation took place. You can move the relocated subdisks (after hot-relocation is complete) to improve performance.

You can also move the relocated subdisks off the spare disk(s) to keep the spare disk space free for future hot-relocation needs. Another reason for moving subdisks is to recreate the configuration that existed before hot-relocation occurred.

During hot-relocation, one of the electronic mail messages sent to `root` is shown in the following example:



```
To: root
Subject: Volume Manager failures on host teal

Attempting to relocate subdisk disk02-03 from plex home-02.
Dev_offset 0 length 1164 dm_name disk02 da_name c0t5d0s2.
The available plex home-01 will be used to recover the data.
```

This message has information about the subdisk before relocation and can be used to decide where to move the subdisk after relocation.

Here is an example message that shows the new location for the relocated subdisk:

```
To: root
Subject: Attempting VxVM relocation on host teal

Volume home Subdisk disk02-03 relocated to disk05-01,
but not yet recovered.
```

Before you move any relocated subdisks, fix or replace the disk that failed (as described in [“Removing and Replacing Disks”](#) on page 63). Once this is done, you can move a relocated subdisk back to the original disk as described in the following sections.

---

**Caution** During subdisk move operations, RAID-5 volumes are not redundant.

---

## Moving and Unrelocating Subdisks using vxdiskadm

---

**Note** You may need an additional license to use this feature.

---

To move the hot-relocated subdisks back to the disk where they originally resided after the disk has been replaced following a failure, use the following procedure:

1. Select menu item 14 (Unrelocate subdisks back to a disk) from the vxdiskadm main menu.
2. This option prompts for the original disk media name first.

Enter the disk media name where the hot-relocated subdisks originally resided at the following prompt:

```
Enter the original disk name [<disk>,list,q,?]
```

If there are no hot-relocated subdisks in the system, vxdiskadm will display `Currently there are no hot-relocated disks, and ask you to press Return to continue.`



3. You are next asked if you want to move the subdisks to a destination disk other than the original disk.

While unrelocating the subdisks, you can choose to move the subdisks to a different disk from the original disk.  
Unrelocate to a new disk [y,n,q,?] (default: n)

4. If moving subdisks to their original offsets is not possible, you can choose to unrelocate the subdisks forcibly to the specified disk, but not necessarily to the same offsets.

Use -f option to unrelocate the subdisks if moving to the exact offset fails? [y,n,q,?] (default: n)

5. If you entered **y** at step 4 to unrelocate the subdisks forcibly, enter **y** or press Return at the following prompt to confirm the operation:

Requested operation is to move all the subdisks which were hot-relocated from disk10 back to disk10 of disk group rootdg.  
Continue with operation? [y,n,q,?] (default: y)

A status message is displayed at the end of the operation.

Unrelocate to disk disk10 is complete.

As an alternative to this procedure, use either the `vxassist` command or the `vxunreloc` command directly, as described in [“Moving and Unrelocating subdisks using vxassist”](#) and [“Moving and Unrelocating Subdisks using vxunreloc”](#) on page 179.

## Moving and Unrelocating subdisks using vxassist

You can use the `vxassist` command to move and unrelocate subdisks. For example, to move the relocated subdisks on `disk05` belonging to the volume `home` back to `disk02`, enter the following command:

```
# vxassist -g rootdg move home !disk05 disk02
```

Here, `!disk05` specifies the current location of the subdisks, and `disk02` specifies where the subdisks should be relocated.

If the volume is enabled, subdisks within detached or disabled plexes, and detached log or RAID-5 subdisks, are moved without recovery of data.

If the volume is not enabled, subdisks within STALE or OFFLINE plexes, and stale log or RAID-5 subdisks, are moved without recovery. If there are other subdisks within a non-enabled volume that require moving, the relocation fails.

For enabled subdisks in enabled plexes within an enabled volume, data is moved to the new location, without loss of either availability or redundancy of the volume.

## Moving and Unrelocating Subdisks using vxunreloc

VxVM hot-relocation allows the system to automatically react to I/O failures on a redundant VxVM object at the subdisk level and then take necessary action to make the object available again. This mechanism detects I/O failures in a subdisk, relocates the subdisk, and recovers the plex associated with the subdisk. After the disk has been replaced, `vxunreloc` allows you to restore the system back to the configuration that existed before the disk failure. `vxunreloc` allows you to move the hot-relocated subdisks back onto a disk that was replaced due to a failure.

When `vxunreloc` is invoked, you must specify the disk media name where the hot-relocated subdisks originally resided. When `vxunreloc` moves the subdisks, it moves them to the original offsets. If you try to unrellocate to a disk that is smaller than the original disk that failed, `vxunreloc` does nothing except return an error.

`vxunreloc` provides an option to move the subdisks to a different disk from where they were originally relocated. It also provides an option to unrellocate subdisks to a different offset as long as the destination disk is large enough to accommodate all the subdisks.

If `vxunreloc` cannot replace the subdisks back to the same original offsets, a `force` option is available that allows you to move the subdisks to a specified disk without using the original offsets. Refer to the `vxunreloc(1M)` manual page for more information.

The following examples demonstrate the use of `vxunreloc`.

### Moving hot-relocated subdisks back to their original disk

Assume that `disk01` failed and all the subdisks were relocated. After `disk01` is replaced, `vxunreloc` can be used to move all the hot-relocated subdisks back to `disk01`.

```
# vxunreloc -g newdg disk01
```

### Moving hot-relocated subdisks to a different disk

The `vxunreloc` utility provides the `-n` option to move the subdisks to a different disk from where they were originally relocated.

Assume that `disk01` failed, and that all of the subdisks that resided on it were hot-relocated to other disks. `vxunreloc` provides an option to move the subdisks to a different disk from where they were originally relocated. After the disk is repaired, it is added back to the disk group using a different name, e.g, `disk05`. If you want to move all the hot-relocated subdisks back to the new disk, the following command can be used:

```
# vxunreloc -g newdg -n disk05 disk01
```

The destination disk should have at least as much storage capacity as was in use on the original disk. If there is not enough space, the unrellocate operation will fail and none of the subdisks will be moved.



## Forcing hot-relocated subdisks to accept different offsets

By default, `vxunreloc` attempts to move hot-relocated subdisks to their original offsets. However, if there some subdisks existed which occupied part or all of the area on the destination disk, `vxunreloc` will fail. In such a case, you have two choices:

- ◆ Move the existing subdisks somewhere else, and then re-run `vxunreloc`.
- ◆ Use the `-f` option provided by `vxunreloc` to move the subdisks to the destination disk, but leave it to `vxunreloc` to find the space on the disk. As long as the destination disk is large enough so that the region of the disk for storing subdisks can accommodate all subdisks, all the hot-relocated subdisks will be “unrelocated” without using the original offsets.

Assume that `disk01` failed and the subdisks were relocated and that you want to move the hot-relocated subdisks to `disk05` where some subdisks already reside. You can use the force option to move the hot-relocated subdisks to `disk05`, but not to the exact offsets:

```
# vxunreloc -g newdg -f -n disk05 disk01
```

## Examining which subdisks were hot-relocated from a disk

If a subdisk was hot relocated more than once due to multiple disk failures, it can still be unrelocated back to its original location. For instance, if `disk01` failed and a subdisk named `disk01-01` was moved to `disk02`, and then `disk02` experienced disk failure, all of the subdisks residing on it, including the one which was hot-relocated to it, will be moved again. When `disk02` was replaced, a `vxunreloc` operation for `disk02` will do nothing to the hot-relocated subdisk `disk01-01`. However, a replacement of `disk01` followed by a `vxunreloc` operation, moves `disk01-01` back to `disk01` if `vxunreloc` is run immediately after the replacement.

After the disk that experienced the failure is fixed or replaced, `vxunreloc` can be used to move all the hot-relocated subdisks back to the disk. When a subdisk is hot-relocated, its original disk-media name and the offset into the disk, are saved in the configuration database. When a subdisk is moved back to the original disk or to a new disk using `vxunreloc`, the information is erased. The original disk-media name and the original offset are saved in the subdisk records. To print all of the subdisks that were hot-relocated from `disk01` in the `rootdg` disk group, use the following command:

```
# vxprint -g rootdg -se 'sd_orig_dmname="disk01"'
```

## Restarting vxunreloc After Errors

`vxunreloc` moves subdisks in three phases:

1. `vxunreloc` creates as many subdisks on the specified destination disk as there are subdisks to be unrelocated. The string `UNRELOC` is placed in the `comment` field of each subdisk record.  
  
Creating the subdisk is an *all-or-nothing* operation. If `vxunreloc` cannot create all the subdisks successfully, none are created, and `vxunreloc` exits.
2. `vxunreloc` moves the data from each subdisk to the corresponding newly created subdisk on the destination disk.
3. When all subdisk data moves have been completed successfully, `vxunreloc` sets the `comment` field to the null string for each subdisk on the destination disk whose `comment` field is currently set to `UNRELOC`.

The `comment` fields of all the subdisks on the destination disk remain marked as `UNRELOC` until phase 3 completes. If its execution is interrupted, `vxunreloc` can subsequently re-use subdisks that it created on the destination disk during a previous execution, but it does not use any data that was moved to the destination disk.

If a subdisk data move fails, `vxunreloc` displays an error message and exits. Determine the problem that caused the move to fail, and fix it before re-executing `vxunreloc`.

If the system goes down after the new subdisks are created on the destination disk, but before all the data has been moved, re-execute `vxunreloc` when the system has been rebooted.

---

**Caution** Do not modify the string `UNRELOC` in the `comment` field of a subdisk record.

---

## Modifying the Behavior of Hot-Relocation

Hot-relocation is turned on as long as `vxrelocd` is running. You leave hot-relocation turned on so that you can take advantage of this feature if a failure occurs. However, if you choose to disable this feature (you do not want the free space on some of your disks used for relocation), prevent `vxrelocd` from starting at system startup time.

Refer to the *VERITAS Volume Manager Installation Guide* for information on how to disable hot-relocation at system startup. You can stop hot-relocation at any time by killing the `vxrelocd` process (this should not be done while a hot-relocation attempt is in progress).

You can make some minor changes to the way `vxrelocd` behaves by either editing the `vxrelocd` line in the startup file that invokes `vxrelocd` (`/etc/rc2.d/S95vxvm-recover`) or killing the existing `vxrelocd` process and



restarting it with different options. After making changes to the way `vxrelocd` is invoked in the startup file, you need to reboot the system so that the changes go into effect. If you choose to kill and restart the daemon instead, make sure that hot-relocation is not in progress when you kill the `vxrelocd` process. You should also restart the daemon immediately so that hot-relocation can take effect if a failure occurs.

You can alter `vxrelocd` behavior as follows:

By default, `vxrelocd` sends electronic mail to `root` when failures are detected and relocation actions are performed. You can instruct `vxrelocd` to notify additional users by adding the appropriate user names as shown here:

```
# nohup vxrelocd root user1 user2 &
```

To reduce the impact of recovery on system performance, you can instruct `vxrelocd` to increase the delay between the recovery of each region of the volume, as shown in the following example:

```
# nohup vxrelocd -o slow[=IOdelay] root &
```

where the optional *IOdelay* value indicates the desired delay (in milliseconds). The default value for the delay is 250 milliseconds.

When executing `vxrelocd` manually, either include `/etc/vx/bin` in your `PATH` or specify `vxrelocd`'s absolute pathname, for example:

```
# PATH=/etc/vx/bin:$PATH  
# export PATH  
# nohup vxrelocd root &
```

or

```
# nohup /etc/vx/bin/vxrelocd root user1 user2 &
```

See the `vxrelocd(1M)` manual page for more information.



## Introduction

The Dynamic Multipathing (DMP) feature of VERITAS Volume Manager (VxVM) provides greater reliability and performance through path failover and load balancing. This feature is available for multiported disk arrays from various vendors (See the *VERITAS Volume Manager Hardware Notes* for information about supported disk arrays.)

Multiported disk arrays can be connected to host systems through multiple paths. In the event of a loss of one connection to the array, DMP automatically routes the I/Os over the other available connections to the array. In case of certain types of disk arrays, DMP also provides greater I/O throughput by balancing the I/O load uniformly across multiple I/O paths to the disk devices.

Unlike prior releases, from VxVM 3.1.1 onwards, the vxdump driver must always be present on the system.

VxVM uses only DMP metanodes to access disk devices connected to the system. DMP exports one metanode for every disk that resides in a supported disk array. This metanode is mapped to a set of operating system device handle(s) and configured with an appropriate multipathing policy. For disks that are not in a supported disk array, each path connected to the disk is exported as a separate DMP metanode.

DMP uses array specific mechanism to detect multiple paths to a disk. DMP can also differentiate between multiple enclosures of a supported array type connected to the same host system.

Multipathing policy used by DMP depends on the characteristics of the disk array. Some disk arrays permit more than one path to be concurrently used for I/O and are categorized as Active/Active. Certain others permit only one path to be used for I/O at a time and are categorized as Active/Passive. For Active/Passive disk arrays the alternate path(s) is used in the event of a path failure.



## Disk Arrays Supported

Disk arrays supported for Dynamic Multipathing (DMP).

- ◆ EMC Symmetrix™
- ◆ HP SureStore™ E Disk Array XP256
- ◆ IBM Enterprise Storage Servers™ (ESS)
- ◆ Hitachi Data Systems™ 5700E Disk Array Subsystem™
- ◆ Hitachi Data Systems 5800E/7700E Disk Array Subsystem™
- ◆ Sun StorEdge A5x00 Array™
- ◆ Sun StorEdge T3 Array™
- ◆ JBOD (Just a Bunch of Disks)
- ◆ SEAGATE disks that return unique serial numbers in standard SCSI inquiry data
- ◆ Storage Computer™ OmniRaid™ disk array. To multipath Storage Computer disk arrays connected to the system while using VxVM 3.1, you must assign a unique *system name* for each disk array connected to a machine. The *RAID-5 Users Manual* at the ftp site *www.storage.com* describes how to set a system name for Storage Computer disk arrays.
- ◆ ECCS™ Synchronix™ Array

## Co-existence with drivers

The DMP feature of VxVM also supports co-existence with the following arrays:

- ◆ Sun's Alternate Pathing driver version 2.3.1 along with Solaris patch 110722-01 for A5x00 and T3 disk arrays.
- ◆ DG CLARiiON with the ATF driver installed on the system
- ◆ SYMBIOS Sun StorEdge A3000 and A3500 Array, only when the RDAC and RM6.22 driver is installed on the system.

For more information on co-existence with various drivers, see the *VERITAS Volume Manager Hardware Notes*.

## SENA Device Support

The A5x00 disk arrays will be claimed by VxVM (DMP) under the SENA category only if the requisite libraries are present on the system at the time of installation/upgrade of VxVM.

These libraries are present by default on Solaris 2.8. For Solaris 2.6 and Solaris 2.7 the following patches must be installed before the VxVM package is installed/upgraded.

- ◆ 107473-03 or higher for Solaris 2.7
- ◆ 105375-20 or higher for Solaris 2.6

## Dynamic Reconfiguration

Dynamic reconfiguration (DR) is a feature available on some high end SUN Enterprise systems. The *board* to be reconfigured is a system board that contains disks controlled by VxVM (in addition to cpus, memory, and other controllers or I/O boards) that can be offlined while the system is still running. You can dynamically reconfigure your system using one of the relevant procedures described in the *VERITAS Volume Manager Hardware Notes*.

## Path Failover Mechanism

DMP enhances system reliability when used with multiported disk arrays. In the event of the loss of one connection to the disk array, DMP automatically selects the next I/O paths for the I/O requests dynamically without action from the administrator.

DMP allows the administrator to indicate to the DMP subsystem in VxVM whether the connection is repaired or restored. This is called DMP reconfiguration. The reconfiguration procedure also allows the detection of newly added devices, as well as devices that are removed after the system is fully booted (if the operating system detects them properly).

## Load Balancing

To provide load balancing across paths, DMP follows the *balanced path mechanism* for active/active disk arrays. Load balancing ensures that I/O throughput can be increased by utilizing the full bandwidth of all paths to the maximum. Sequential I/Os starting within a certain range are sent down the same path in order to optimize I/O throughput using disk track caches. However, large sequential I/Os that do not fall within this range are distributed across paths to take the advantage of I/O load balancing.

For active/passive disk arrays, I/Os are sent down the primary path until it fails. Once the primary path fails, I/Os are then switched over to the other available primary paths or secondary paths. To avoid the continuous transfer of ownership of LUNs from one controller to another, which results in severe I/O slowdown, load balancing across paths is not done for active/passive disk arrays.



## Booting From DMP Devices

When the root disk is placed under VxVM control, it is automatically accessed as a DMP device with one path if it is a single disk, or with multiple paths if the disk is part of a multiported disk array. By encapsulating the root disk, system reliability is enhanced against loss of one or more of the existing physical paths to a disk.

## Enabling and Disabling Input/Output (I/O) Controllers

DMP allows the administrator to turn off I/Os to a host I/O controller to perform administrative operations. It can be used for maintenance of controllers attached to the host or a disk array supported by VxVM. I/O operations to the host I/O controller can be turned on after the maintenance task is completed. This operation can be accomplished using the `vxddmpadm` command provided with VxVM.

For example, if the system has a StorEdge A5000<sup>™</sup> array and the user needs to change an A5000 Interface Board connected to this disk array, the `vxddmpadm` command is used to display a list of host I/O controllers connected on this A5000 interface board. After the host I/O controllers are disabled, further I/O to the disks that are accessed through these controllers is stopped.

The Interface Board can then be replaced without causing any disruption to ongoing I/Os to disks present on this disk array. This is required because normally, for active/active type disk arrays (as in this example), VxVM uses the balanced path mechanism to schedule I/Os to a disk with multiple paths to it. As a result, I/Os may go through any path at any given point in time.

For active/passive type disk arrays, I/Os are scheduled by VxVM to the primary path until a failure is encountered. Therefore, to change an interface card on the disk array or a card on the host (when possible) that is connected to the disk array, the I/O operations to the host I/O controllers are disabled. This allows all I/Os to be shifted over to an active secondary path or an active primary path on another I/O controller before the hardware is changed.

After the operation is over, the paths through these controllers can be put back into action by using the `enabled` option of the `vxddmpadm` command.

VxVM does not allow you to disable the last active path to the root disk.

## Displaying DMP Database Information

The `vxddmpadm` command can be used to list DMP database information and perform other administrative tasks. This command allows you to list all the controllers on the systems (connected to disks) and other related information stored in the DMP database. This information can be used to locate system hardware and make a decision regarding which controllers to enable/disable.

The `vxddmpadm` command also provides you with other useful information such as disk array serial numbers and the list of DMP devices (disks) that are connected to the disk array, the list of paths that go through a particular controller, and so on.

## Administrative Tasks

The `vxddmpadm` utility is an administrative interface to the Dynamic Multipathing (DMP) subsystem in VxVM.

You can use the `vxddmpadm` utility to perform the following tasks.

- ◆ list all controllers connected to disks attached to the host
- ◆ list all the paths connected to a particular controller
- ◆ list all paths under a DMP device
- ◆ retrieve the name of the DMP device corresponding to a particular path
- ◆ enables or disables a host controller on the system
- ◆ rename an enclosure

The following sections cover these tasks in detail along with sample output.

### Retrieving Information About a DMP Node

The following command displays the DMP node that controls a particular physical path:

```
# vxddmpadm getdmpnode nodename=c3t2d1s2
```

The physical path can be specified as the `nodename` attribute, which must be a valid path listed in the `/dev/rdisk` directory.

The above command displays output such as the following:

NAME	STATE	ENCLR-TYPE	PATHS	ENBL	DSBL	ENCLR-NAME
c3t2d1s2	ENABLED	T300	2	2	0	purple0

Use the `enclosure` attribute with `getdmpnode` to obtain a list of all DMP nodes for the specified enclosure.

```
# vxddmpadm getdmpnode enclosure=purple0
```

NAME	STATE	ENCLR-TYPE	PATHS	ENBL	DSBL	ENCLR-NAME
c2t1d0s2	ENABLED	T300	2	2	0	purple0
c2t1d1s2	ENABLED	T300	2	2	0	purple0
c2t1d2s2	ENABLED	T300	2	2	0	purple0
c2t1d3s2	ENABLED	T300	2	2	0	purple0



## Displaying All Paths Controlled by a DMP Node

The following command displays the paths controlled by the specified DMP node:

```
# vxdmpadm getsubpaths dmpnodename=c2t1d0s2
```

The specified DMP node must be a valid node in the `/dev/vx/rdmp` directory. `getsubpaths` can also obtain all paths through a particular host disk controller. For example,

```
NAME          STATE      PATH-TYPE  CTLR-NAME  ENCLR-TYPE  ENCLR-NAME
=====
c2t1d0s2     ENABLED   PRIMARY   c2         T300        purple0
c3t2d0s2     ENABLED   SECONDARY c3         T300        purple0
# vxdmpadm getsubpaths ctlr=c2
NAME          STATE      PATH-TYPE  DMPNODENAME  ENCLR-TYPE  ENCLR-NAME
=====
c2t1d0s2     ENABLED   PRIMARY   c2t1d0s2    T300        purple0
c2t1d1s2     ENABLED   PRIMARY   c2t1d1s2    T300        purple0
c2t1d2s2     ENABLED   SECONDARY c2t1d2s2    T300        purple0
c2t1d3s2     ENABLED   SECONDARY c2t1d3s2    T300        purple0
```

## Listing Information About Host I/O Controllers

The following command lists attributes of all host I/O controllers on the system:

```
# vxdmpadm listctlr all
```

This command displays output such as the following:

```
CTLR-NAME      ENCLR-TYPE      STATE      ENCLR-NAME
=====
c0              OTHER           ENABLED    others0
c1              SEAGATE         ENABLED    seagate0
c2              T300           ENABLED    purple0
c3              T300           ENABLED    purple0
```

This form of the command lists controllers belonging to a specified enclosure and enclosure type:

```
# vxdmpadm listctlr enclosure=purple0 type=T300
```

This command displays output such as the following:

```
CTLR-NAME      ENCLR-TYPE      STATE      ENCLR-NAME
=====
c2              T300           ENABLED    purple0
c3              T300           ENABLED    purple0
```



## Disable Controller

Disables I/O to a host disk controller. This prevents DMP from issuing I/Os through the specified controller. The command is blocked until all pending I/Os issued through the specified disk controller are completed.

To disable a controller, use the following command:

```
# vxdmpadm disable ctrl=ctrl
```

Before detaching a system board, stop all I/Os to the disk controllers connected to the board. Execute the `vxdmpadm disable` command, then run the Dynamic Reconfiguration (DR) facility provided by Sun. Do this for every controller connected to the system board being detached. The disable operation fails if it is issued to a controller connected to the root disk through a single path. If there is a single path connected to a disk, the disable command fails with an error message. Use the `-f` option to forcibly disable the controller.

## Enable Controller

Enable allows a previously disabled host disk controller to accept I/Os. This operation succeeds only if the controller is accessible to the host and I/O can be performed on it. When connecting Active/Passive disk arrays in a non-clustered environment, enable will result in a failback of I/Os to the primary path. enable can be executed to allow I/Os to the controllers on the system board that was detached earlier.

To enable a controller, use the following command:

```
# vxdmpadm enable ctrl=ctrl
```

## Listing Information About Enclosures

To display the attributes of a specified enclosure, use the following command:

```
# vxdmpadm listenclosure purple0
```

The following example displays all attributes associated with the enclosure named purple0:

```
ENCLR_NAME ENCLR_TYPE ENCLR_SNO MODE STATUS
=====
purple0 T300 60020f20000001a9000 PRIVATE CONNECTED
```

The following command lists attributes for all enclosures in a system:

```
# vxdmpadm listenclosure all
```



The following is example output from this command:

ENCLR_NAME	ENCLR_TYPE	ENCLR_SNO	MODE	STATUS
others0	OTHER	OTHER_DISKS	PRIVATE	CONNECTED
seagate0	SEAGATE	SEAGATE_DISKS	PRIVATE	CONNECTED
purple0	T300	60020f20000001a90000	PRIVATE	CONNECTED

## Renaming an Enclosure

The `vxdmpadm setattr` command can be used to assign a meaningful name to an existing enclosure, for example:

```
# vxdmpadm setattr enclosure purple0 name=VMGRP_1
```

This example changes the name of enclosure from `purple0` to `VMGRP_1`. The following output from the command `vxdmpadm listenclosure all` shows the changed name.

ENCLR_NAME	ENCLR_TYPE	ENCLR_SNO	MODE	STATUS
others0	OTHER	OTHER_DISKS	PRIVATE	CONNECTED
seagate0	SEAGATE	SEAGATE_DISKS	PRIVATE	CONNECTED
VMGRP_1	T300	60020f20000001a90000	PRIVATE	CONNECTED

## Starting the DMP Restore Daemon

The DMP restore daemon re-examines the condition of paths at a specified interval. The type of analysis it performs on the paths depends on the specified policy.

Use the `start restore` command to start the restore daemon and specify the policy:

```
# vxdmpadm start restore policy=check_disabled
```

The `check_disabled` policy (the default) checks the condition of paths that were previously disabled due to hardware failures, and revives them if they are back online. If the policy is set to `check_all`, the restore daemon analyzes all paths in the system and revives the paths that are back online, as well as disabling the paths that are inaccessible.

To disable a controller, use the following command:

```
# vxdmpadm disable ctrl=ctrl
```

The DMP restore daemon does not change the disabled state of the path through this controller.

The command `vxdmpadm start restore` is used to set the interval of polling. For example, the polling interval is set to 400 seconds using the following command:

```
# vxdmpadm start restore interval=400
```





The default interval is 300 seconds. Decreasing this interval can adversely affect system performance. To change the interval or policy, you must stop the restore daemon and restart it with new attributes.

## Stopping the DMP Restore Daemon

Use the following command to stop the DMP restore daemon:

```
# vxdmpadm stop restore
```

---

**Note** Automatic path failback stops if the restore daemon is stopped.

---

## Displaying the Status of the DMP Restore Daemon

Use the following command to display the status of the automatic path restoration daemon, its polling interval, and the policy that it uses to check the condition of paths:

```
# vxdmpadm stat restored
```

This produces output such as the following:

```
The number of daemons running : 1
The interval of daemon: 300
The policy of daemon: check_disabled
```

## Displaying Information About the DMP Error Daemons

To list the number of error daemons that are running, use the following command:

```
# vxdmpadm stat error
```

This command displays information similar to the following:

```
The number of daemons running : 1
```

## Disable Multipathing

Use the `vxdiskadm` menu options to prevent or allow multipathing. This menu option also suppresses devices from VxVM's view. For more information on this topic refer to the chapter "[Administering Disks](#)."





## Introduction

This chapter discusses the cluster functionality provided with VERITAS Volume Manager (VxVM). VxVM includes an optional cluster feature that enables it to be used in a cluster environment.

---

**Note** You need an additional license to use this feature.

---

## Cluster Functionality Overview

The cluster functionality in VxVM allows multiple hosts to simultaneously access and manage a given set of disks under VxVM control (VM disks). A cluster is a set of hosts sharing a set of disks; each host is referred to as a node in the cluster. The nodes are connected across a network. If one node fails, the other nodes can still access the disks. The cluster feature presents the same logical view of the disk configurations (including changes) on all nodes. When the cluster feature is enabled, VxVM objects are capable of being shared by all of the nodes in a cluster.

---

**Note** With cluster support enabled, VxVM supports up to four nodes per cluster.

---

The sections that follow provide more information on the cluster functionality provided by VxVM.



## Shared VxVM Objects

When the cluster feature is enabled, VxVM objects can be shared by all nodes in a given cluster.

The cluster feature allows for two types of disk groups:

- ◆ *Private disk groups*—belong to only one node. A private disk group is only imported by one system. Disks in a private disk group may be physically accessible from one or more systems, but actual access is restricted to one system only.
- ◆ *Cluster-shareable disk groups*—shared by all nodes. A cluster-shareable (or *shared*) disk group is imported by all cluster nodes. Disks in a cluster-shareable disk group must be physically accessible from all systems that may join the cluster.

In a cluster, most disk groups are shared. However, the root disk group (`rootdg`) is always a private disk group.

Disks in a shared disk group are accessible from all nodes in a cluster, allowing applications on multiple cluster nodes to simultaneously access the same disk. A volume in a shared disk group can be simultaneously accessed by more than one node in the cluster, subject to licensing and disk group activation mode descriptions.

A shared disk group must be activated on a node in order for the volumes in the disk group to become accessible for application I/O from that node. The ability of applications to read or write to volumes is dictated by the activation mode of the disk group. Valid activation modes for a shared disk group are *exclusive-write*, *shared-write*, *read-only*, *shared-read* and *off* (or inactive) These activation modes as described in detail in the table “[Activation Modes for Shared Disk Groups.](#)”

Activation Modes for Shared Disk Groups

<b>Exclusive write</b>	The node has exclusive write access to the disk group. No other node can activate the disk group for write access.
<b>Read only</b>	The node has read access to the disk group and denies write access for all other nodes in the cluster. The node has no write access to the disk group. Attempts to activate a disk group for either of the write modes on other nodes will fail.
<b>Shared read</b>	The node has read access to the disk group. The node has no write access to the disk group, however other nodes can obtain write access.
<b>Shared write</b>	The node has write access to the disk group.
<b>Off</b>	The node has neither read nor write access to the disk group. Query operations on the disk group are permitted.

---

**Note** Disk group activation was a new feature in VERITAS Volume Manager 3.0. To maintain compatibility with previous releases, activation modes are, by default, transparent to VxVM utilities. Shared disk groups are automatically activated in shared-write mode.

---

Special uses of clusters, such as high availability (HA) applications and off-host backup, can use disk group activation to explicitly control volume I/O capability from different nodes in the cluster. Use of activation modes is described in “[Disk Group Activation](#)” on page 201.

## Limitations of Shared Disk Groups in VxVM

The new features introduced in VERITAS Volume Manager 3.0 are available in private disk groups but are not yet supported for shared disk groups. These features include layered volumes (striped-mirror and concatenated-mirror), task monitor, and online relayout.

Only raw device access is performed via the cluster feature. Shared volumes with file systems are not supported.

The cluster feature does not currently support RAID-5 volumes in cluster-shareable disk groups. RAID-5 volumes can, however, be used in private disk groups attached to specific nodes of a cluster.

If a disk group that contains unsupported objects is imported as shared, deport the disk group, reorganize its volumes into supported layouts, and then reimport it as shared.

## How Cluster Volume Management Works

The cluster feature works together with an externally-provided *cluster manager*, which is a daemon that informs VxVM of changes in cluster membership. Each node starts up independently and has its own copies of the operating system, VxVM with cluster support, and the cluster manager. When a node *joins* a cluster, it gains access to shared disks. When a node *leaves* a cluster, it no longer has access to those shared disks. The system administrator joins a node to a cluster by starting the cluster manager on that node.

The figure “[Example of a 4-Node Cluster](#)” on page 196, illustrates a simple cluster arrangement. All of the nodes are connected by a network. The nodes are then connected to a cluster-shareable disk group. To the cluster manager, all nodes are the same. However, the cluster feature requires that one node act as the *master node*; the other nodes are *slave nodes*. The master node is responsible for coordinating certain VxVM activities. VxVM software determines which node performs the master function (any node is capable of



being a master node); this role only changes if the master node leaves the cluster. If the master leaves the cluster, one of the slave nodes becomes the new master. In the figure, node 1 is the master node and nodes 2, 3 4 are slave nodes.

Example of a 4-Node Cluster

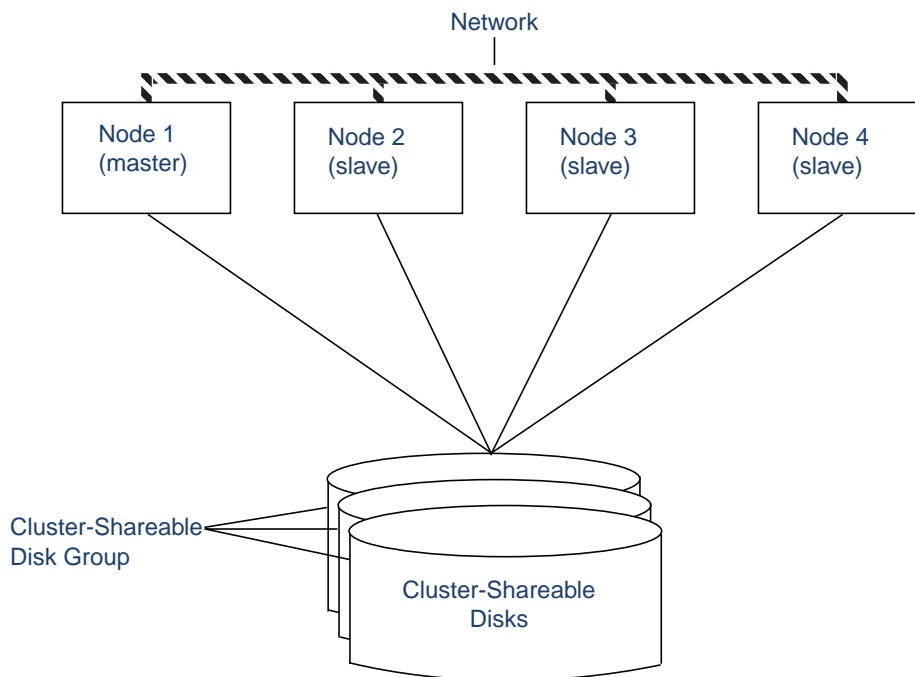

The system administrator designates a disk group as cluster-shareable using the `vxdg` utility (see “[Importing Disk Groups as Shared](#)” on page 209 for more information). Once a disk group is imported as cluster-shareable for one node, the disk headers are marked with the cluster ID. When other nodes join the cluster, they will recognize the disk group as being cluster-shareable and import it. The system administrator can import or deport a shared disk group at any time; the operation takes place in a distributed fashion on all nodes.

Each physical disk is marked with a unique disk ID. When the cluster starts up on the master, it imports all the shared disk groups (except for any that have the `noautoimport` attribute set). When a slave tries to join, the master sends it a list of the disk IDs it has imported and the slave checks to see if it can access all of them. If the slave cannot access one of the imported disks on the list, it abandons its attempt to join the cluster. If it can access all of the disks on the list, it imports the same set of shared disk groups as the master and joins the cluster. When a node leaves the cluster, it deports all its imported shared disk groups, but they remain imported on the surviving nodes.

Any reconfiguration to a shared disk group is performed with the cooperation of all nodes. Configuration changes to the disk group happen simultaneously on all nodes and the changes are identical. These changes are atomic in nature, so they either occur simultaneously on all nodes or do not occur at all.

All members of the cluster can have simultaneous read and write access to any cluster-shareable disk group depending on the activation mode. Access by the active nodes of the cluster is not affected by a failure in any other node. The data contained in a cluster-shareable disk group is available as long as at least one node is active in the cluster. Regardless of which node accesses the cluster-shareable disk group, the configuration of the disk group looks the same. Applications running on each node can access the data on the VM disks simultaneously.

---

**Note** VxVM does not protect against simultaneous writes to shared volumes by more than one node. It is assumed that any consistency control is done at the application level (using a distributed lock manager, for example).

---

## Configuration and Initialization

Before any nodes can join a new cluster for the first time, the system administrator must supply certain configuration information. This information is supplied during cluster manager setup and is normally stored in some type of cluster manager configuration database. The precise content and format of this information is dependent on the characteristics of the cluster manager. Information required by VxVM is as follows:

- ◆ cluster ID
- ◆ node IDs
- ◆ network addresses of nodes
- ◆ port addresses

When a node joins the cluster, this information is automatically loaded into VxVM on that node at node startup time.

Node initialization is effected through the cluster manager startup procedure, which brings up the various cluster components (such as VxVM with cluster support, the cluster manager, and a distributed lock manager) on the node. Once it is complete, applications may be started. The system administrator invokes the cluster manager startup procedure on each node to be joined to the cluster.

For VxVM in a cluster environment, initialization consists of loading the cluster configuration information and joining the nodes in the cluster. The first node to join becomes the master node, and later nodes (slaves) join to the master. If two nodes join simultaneously, VxVM software chooses the master. Once the join for a given node is complete, that node has access to the shared disks.



## Cluster Reconfiguration

Any time there is a change in the state of the cluster (in the form of a node leaving or joining), a *cluster reconfiguration* occurs. The cluster manager for each node monitors other nodes in the cluster and informs VxVM when there is a change in cluster membership. VxVM then takes appropriate action.

During a cluster reconfiguration, I/O to shared disks is suspended. It is resumed when the reconfiguration completes. Applications may therefore appear to be frozen for a short time.

If other operations (such as VxVM operations or recoveries) are in progress, the cluster reconfiguration can be delayed until those operations have completed. Volume reconfigurations (described later) do not take place at the same time as cluster reconfigurations. Depending on the circumstances, an operation may be held up and restarted later. In most cases, cluster reconfiguration takes precedence. However, if the volume reconfiguration is in the commit stage, it completes first.

For more information on cluster reconfiguration, see “[vxclust Utility](#)” on page 212 and “[vxclustadm Utility](#)” on page 213.

## Volume Reconfiguration

*Volume reconfiguration* is the process of creating, changing, and removing the VxVM objects in the configuration (such as disk groups, volumes, mirrors, and so on). In a cluster, this process is performed with the cooperation of all nodes. Volume reconfiguration is distributed to all nodes; identical configuration changes occur on all nodes simultaneously.

---

**Note** Volume reconfiguration is initiated and coordinated by the master node, so the system administrator must run the utilities that request changes to VxVM objects on the master node.

---

The `vxconfigd` daemons play an active role in volume reconfiguration. For the reconfiguration to succeed, a `vxconfigd` daemon must be running on each of the nodes.

The utility on the master node contacts its local `vxconfigd` daemon, which performs local checking to make sure that a requested change is reasonable. For instance, it fails an attempt to create a new disk group when one with the same name already exists. The `vxconfigd` daemon on the master node then sends messages with the details of the changes to the `vxconfigd` daemons on all other nodes in the cluster. The `vxconfigd` daemons on the slave nodes then perform their own checking. For example, a slave node checks that it does not have a private disk group with the same name as the one being created; if the operation involves a new disk, each node checks that it can access that disk. When all of the `vxconfigd` daemons on all nodes agree that the proposed change is reasonable, each `vxconfigd` notifies its kernel. The kernels then cooperate to either



commit or abort the transaction. Before the transaction can commit, all of the kernels ensure that no I/O is underway. The master is responsible for initiating a reconfiguration and coordinating the transaction commit.

If a `vxconfigd` daemon on any node goes away during a reconfiguration process, all nodes are notified and the operation fails. If any node leaves the cluster, the operation fails unless the master has already committed it. If the master leaves the cluster, the new master (which was a slave previously) either completes or fails the operation. This depends on whether or not it received notification of successful completion from the previous master. This notification is done in such a way that if the new master does not receive it, neither does any other slave.

If a node attempts to join the cluster while a volume reconfiguration is being performed, the results depend on how far the reconfiguration has progressed. If the kernel is not yet involved, the volume reconfiguration is suspended and restarted when the join is complete. If the kernel is involved, the join waits until the reconfiguration is complete.

When an error occurs (such as when a check on a slave fails or a node leaves the cluster), the error is returned to the utility and a message is issued to the console on the master node to identify the node on which the error occurred.

## Node Shutdown

The system administrator can shut down the cluster on a given node by invoking the cluster manager's shutdown procedure on that node. This terminates cluster components after cluster applications have been stopped. VxVM supports *clean node shutdown*, which is the ability of a node to leave the cluster gracefully when all access to shared volumes has ceased. The host is still operational, but cluster applications cannot be run on it.

The cluster feature maintains global state information for each volume. This enables VxVM to determine accurately which volumes need recovery when a node crashes. When a node leaves the cluster due to a crash or by some other means that is not clean, VxVM determines which volumes may have writes that have not completed and the master resynchronizes those volumes. If dirty region logging (DRL) is active for any of those volumes, it is used.

Clean node shutdown must be used after, or in conjunction with, a procedure to halt all cluster applications. Depending on the characteristics of the clustered application and its shutdown procedure, a successful shutdown can require a lot of time (minutes to hours). For instance, many applications have the concept of "draining," where they accept no new work, but complete any work in progress before exiting. This process can take a long time if, for example, a long-running transaction is active.

When the VxVM shutdown procedure is invoked, the procedure checks all volumes in all shared disk groups on the node that is being shut down. The procedure then either continues with the shutdown, or fails for the following reasons:



- ◆ If all volumes in shared disk groups are closed, VxVM makes them unavailable to applications. Because all nodes are informed that these volumes are closed on the leaving node, no resynchronization is performed.
- ◆ If any volume in a shared disk group is open, the shutdown procedure fails. The shutdown procedure can be retried repeatedly until it succeeds. There is no timeout checking in this operation—it is intended as a service that verifies that the clustered applications are no longer active.

---

**Note** Once shutdown succeeds, the node has left the cluster. It is not possible to access the shared volumes until the node joins the cluster again.

---

Since shutdown can be a lengthy process, other reconfigurations can take place while shutdown is in progress. Normally, the shutdown attempt is suspended until the other reconfiguration completes. However, if it is already too far advanced, the shutdown may complete first.

### Node Abort

If a node does not leave cleanly, this is because the host crashed or because some cluster component decided to make the node leave on an emergency basis. The ensuing cluster reconfiguration calls the VxVM abort function. This function makes an attempt to halt all access to shared volumes at once, though the operation does wait until I/O that is at the disk completes.

I/O operations that have not yet been started are failed, and the shared volumes are removed. Applications that were accessing the shared volumes therefore fail with errors.

After a node abort or crash, the shared volumes must be recovered (either by a surviving node or by a subsequent cluster restart) because it is very likely that there are unsynchronized mirrors.

### Cluster Shutdown

When all the nodes in the cluster leave, the determination of whether or not the shared volumes should be recovered has to be made at the next cluster startup. If all nodes left cleanly, there is no need for recovery. If the last node left cleanly and resynchronization resulting from the non-clean leave of earlier nodes was complete, there is also no need for recovery. However, recovery must be performed if the last node did not leave cleanly or if resynchronization from previous leaves was not complete.

## Disk Status Resolution in Clusters

The nodes in a cluster must always agree on the status of a disk. In particular, if one node cannot write to a given disk, all nodes must stop accessing that disk before the results of the write operation are returned to the caller. Therefore, if a node cannot contact a disk, it should contact another node to check on the disk's status. If the disk fails, no node can access it and the nodes can agree to detach the disk. If the disk does not fail, but rather the access paths from some of the nodes fail, the nodes cannot agree on the status of the disk. Either of the following policies for resolving this type of discrepancy may be applied:

- ◆ Under the *global* connectivity policy, the detach occurs cluster-wide (globally), if any node in the cluster reports a disk failure. This is the default policy.
- ◆ Under the *local* connectivity policy, in the event of disks failing, the failures are confined to the particular nodes that saw the failure. Note that an attempt is made to communicate with all nodes in the cluster to ascertain the disks' usability. If all nodes report a problem with the disks, a cluster-wide detach occurs.

See “[Setting the Connectivity Policy on a Shared Disk Group](#)” on page 209 for information on how to use the `vxedit` command to set the connectivity policy on a shared disk group.

## Disk Group Activation

Disk group activation controls volume I/O capability from different nodes in the cluster. It is not possible to activate a disk group on a given node if it is activated in a conflicting mode on another node in the cluster.

The table “[Allowed and Conflicting Activation Modes](#)” summarizes the allowed and conflicting activation modes for shared disk groups:

Allowed and Conflicting Activation Modes

Disk group activated in cluster as...	Attempt to activate disk group on another node as...			
	Exclusive write	Read only	Shared read	Shared write
Exclusive write	Fails	Fails	Succeeds	Fails
Read only	Fails	Succeeds	Succeeds	Fails
Shared read	Succeeds	Succeeds	Succeeds	Succeeds
Shared write	Fails	Fails	Succeeds	Succeeds

To place activation modes under user control, create a defaults file `/etc/default/vxdg` containing the following line:

```
default_activation_mode=activation-mode
```



The *activation-mode* is one of `exclusive-write`, `read-only`, `shared-read`, `shared-write`, or `off`.

---

**Note** When enabling activation using the defaults file, it is recommended that the defaults file be identical on all nodes in the cluster. Otherwise, the results of activation are unpredictable.

---

When a shared disk group is created or imported, it is activated in the specified mode. When a node joins the cluster, all shared disk groups accessible from the node are activated in the specified mode.

If the defaults file is edited when the `vxconfigd` daemon is running, the `vxconfigd` process must be restarted for the changes in the defaults file to take effect.

---

**Note** If the default activation mode is anything other than `off`, an activation following a cluster join, or a disk group creation or import can fail if another node in the cluster has activated the disk group in a conflicting mode.

---

You can also use the `vxchg` command to change the activation mode on a shared disk group as described in “[Changing the Activation Mode on a Shared Disk Group](#)” on page 209.

For a description of how to configure a volume so that it can only be opened by a single node in a cluster, see “[Creating Volumes with Exclusive Open Access by a Node](#)” on page 211 and “[Setting Exclusive Open Access to a Volume by a Node](#)” on page 211.

## Dirty Region Logging (DRL) and Cluster Environments

*Dirty region logging* (DRL) is an optional property of a volume that provides speedy recovery of mirrored volumes after a system failure. DRL is supported in cluster-shareable disk groups. This section provides a brief overview of DRL and describes how DRL behaves in a cluster environment. For more information on DRL, see “[Dirty Region Logging \(DRL\)](#)” on page 35.

DRL keeps track of the regions that have changed due to I/O writes to a mirrored volume and uses this information to recover only the portions of the volume that need to be recovered. DRL logically divides a volume into a set of consecutive regions and maintains a dirty region log that contains a status bit representing each region of the volume. *Log subdisks* are used to store the dirty region log of a volume that has DRL enabled. A volume with DRL has at least one log subdisk, which is associated with one of the volume plexes.

Before writing any data to the volume, the regions being written are marked dirty in the log. If a write causes a log region to become dirty when it was previously clean, the log is synchronously written to disk before the write operation can occur. A log region becomes clean again after the write to the mirror is complete. On system restart, VxVM recovers only those regions of the volume which are marked as dirty in the dirty region log.

In a cluster environment, the VxVM implementation of DRL differs slightly from the normal implementation. The following sections outline some of the differences and discuss some aspects of the cluster environment implementation.

## Log Format and Size

As in the non-clustered case, the dirty region log in clusters exists on a log subdisk in a mirrored volume.

A dirty region log has a recovery map and a single active map. A dirty region log in clusters, however, has one recovery map and multiple active maps (one for each node in the cluster). Unlike VxVM, the cluster feature places the recovery map at the beginning of the log.

The dirty region log size in clusters is typically larger than in non-clustered systems, as it must accommodate active maps for all nodes in the cluster plus a recovery map. The size of each map within the dirty region log is one or more whole blocks. The `vxassist` command automatically allocates a sufficiently large dirty region log.

The log size depends on the volume size and the number of nodes. The log must be large enough to accommodate all maps (one map per node plus a recovery map). Each map must be one block long for each two gigabytes of volume size. For a two-gigabyte volume in a two-node cluster, a log size of three blocks (one block per map) is sufficient; this is the minimum log size. A four-gigabyte volume in a four-node cluster requires a log size of ten blocks, and so on.

When nodes are added to an existing cluster, the existing DRL logs must be detached and removed (using the `vxplex -o rm dis` command) and then recreated (using the `vxassist addlog` command). The use of these two commands increases the log sizes to accommodate maps for the additional nodes.

## Compatibility

Except for the addition of a cluster-specific magic number, DRL headers in a cluster environment are the same as their non-clustered counterparts.

It is possible to import a VxVM disk group (and its volumes) as a shared disk group in a cluster environment and vice versa. However, the dirty region logs of the imported disk group may be considered invalid and a full recovery may result.



If a shared disk group is imported by a VxVM system without cluster support, VxVM considers the logs of the shared volumes to be invalid and conducts a full volume recovery. After this recovery completes, VxVM uses DRL.

The cluster feature can perform a DRL recovery on a non-shared VxVM volume. However, if a VxVM volume is moved to a VxVM system with cluster support and imported as shared, the dirty region log is probably too small to accommodate all the nodes in the cluster. The cluster feature then marks the log invalid and performs a full recovery anyway. Similarly, moving a DRL volume from a two-node cluster to a four-node cluster can result in too small a log size, which the cluster feature handles with a full volume recovery. In both cases, the system administrator is responsible for allocating a new log of sufficient size.

## How DRL Works in a Cluster Environment

When one or more nodes in a cluster crash, DRL must handle the recovery of all volumes in use by those nodes when the crash(es) occurred. On initial cluster startup, all active maps are incorporated into the recovery map during the `volume start` operation.

Nodes that crash (that is, leave the cluster as “dirty”) are not allowed to rejoin the cluster until their DRL active maps have been incorporated into the recovery maps on all affected volumes. The recovery utilities compare a crashed node’s active maps with the recovery map and make any necessary updates before the node can rejoin the cluster and resume I/O to the volume (which overwrites the active map). During this time, other nodes can continue to perform I/O.

The VxVM kernel tracks which nodes have crashed. If multiple node recoveries are underway in a cluster at a given time, their respective recoveries and recovery map updates can compete with each other. The VxVM kernel tracks changes in the DRL recovery state and prevents I/O operation collisions.

The master performs volatile tracking of DRL recovery map updates for each volume and prevents multiple utilities from changing the recovery map simultaneously.

## Upgrading Cluster Functionality

The rolling upgrade feature allows an administrator to upgrade the version of VxVM running in a cluster without shutting down the entire cluster. To install the new version of VxVM running on a cluster, the system administrator can pull out one node from the cluster, upgrade it and then join the node back into the cluster. This is done for each node in the cluster.

Every VERITAS Volume Manager release, starting with Release 3.1, has a *cluster protocol version number* associated with it, which is different from the release number. The cluster protocol version is stored in the `/etc/vx/volboot` file. In a new installation of VxVM, the `volboot` file does not exist in the `/etc/vx` directory. The `vxdctl init` command creates this file and sets the cluster protocol version to the highest supported version.

A new VERITAS Volume Manager release supports two versions of cluster protocol. The lower version number corresponds to the existing VERITAS Volume Manager release. This has a fixed set of features and communication protocols. The higher version number corresponds to a new release of VxVM which has a new set of these features. If the new release of VxVM does not have any functional or protocol changes, the cluster protocol version remains unchanged, for example, in case of bug fixes or minor changes. In this case, the `vxdctl upgrade` command need not be executed.

During the rolling upgrade operation each node must be shut down and the VERITAS Volume Manager release with the latest cluster protocol version must be installed. All nodes that have the new release of VxVM continue to use the lower level version. A slave node that has the new cluster protocol version installed tries to join the cluster. If the new cluster protocol version is not in use on the master node, it rejects the join and provides the current cluster protocol version to the slave node. The slave retries the join with the cluster protocol version provided by the master node. If the join fails at this point, the cluster protocol version on the master node is out of range of the protocol versions supported by the joining slave. In such a situation the system administrator must upgrade the cluster through each intermediate release of VxVM to reach the latest supported cluster protocol version.

All nodes are upgraded to the latest cluster protocol version and the new features are available.

Once all nodes have the new release installed, the `vxdctl upgrade` command must be run on the Master node to switch to the higher cluster protocol version. See “[vxdctl Utility](#)” on page 215 for more information.



## FastResync and Cluster Environments

The FastResync feature is supported for shared volumes. The maps that FastResync uses to track changes are distributed across the nodes of the cluster. The non-persistence of FastResync maps is generally not a problem in a cluster environment because the crash of a single node does not cause the loss of the maps. Only one node in the cluster needs to be active for the FastResync maps to be available.

Since the region size must be the same on all nodes in a cluster for a shared volume, the value of the `vol_fmr_logsz` tunable on the master overrides the tunable values on the slaves, if the slave values are different. Because the value of a shared volume can change, the `vol_fmr_logsz` tunable value is retained for the life of the volume or until FastResync is turned on for the volume. (See the description of the `vol_fmr_logsz` tunable on page 230 for more information.)

The map updates are applied under the direction of the master node. When the master node distributes updates to all nodes, all updates are applied either to all or to none of the nodes. The master node orchestrates a two-phase commitment for applying any updates as shown in “[Bitmap Clusterization](#)” on page 207.



## Bitmap Clusterization

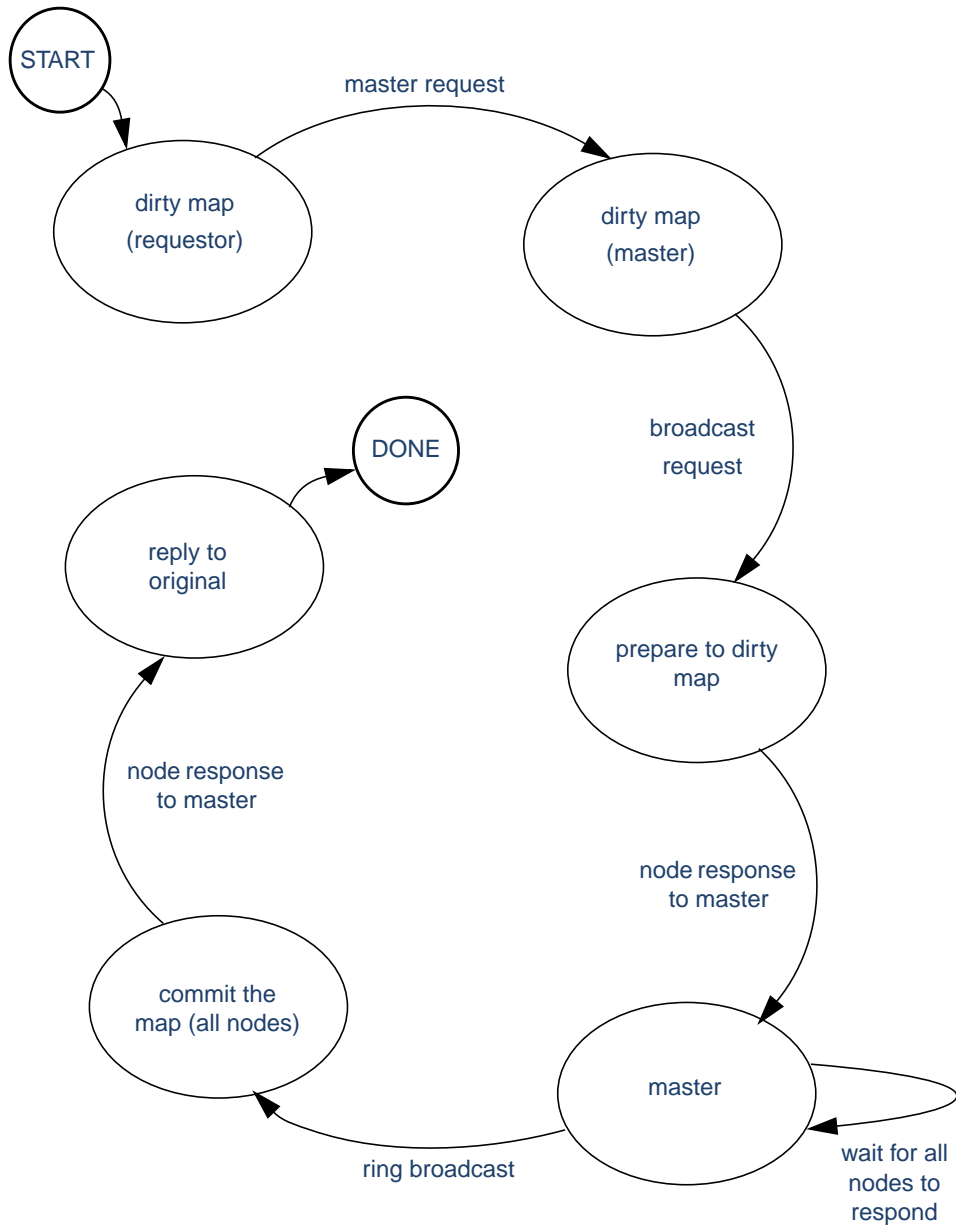

## Administering VxVM in Cluster Environments

The following sections describe additional procedures for administering disks, disk groups and volumes when VxVM is used in cluster environments.

---

**Note** Most VxVM commands require superuser or equivalent privileges.

---

### Determining if a Disk is Shareable

The `vxdisk` utility manages VxVM disks. To use the `vxdisk` utility to determine whether a disk is part of a cluster-shareable disk group, use the following command:

```
# vxdisk list accessname
```

where *accessname* is the disk access name (or device name).

A portion of the output from this command (for the device `c4t1d0`) is as follows:

```
Device:      c4t1d0
devicetag:   c4t1d0
type:        sliced
clusterid:   cvm2
disk:        name=disk01 id=963616090.1034.cvm2
timeout:     30
group:       name=rootdg id=963616065.1032.cvm2
flags:       online ready autoconfig shared imported
...
```

Note that the `clusterid` field is set to `cvm2` (the name of the cluster), and the `flags` field includes an entry for `shared`. When a node is not joined, the `flags` field contains the `autoimport` flag instead of `imported`.

### Creating a Shared Disk Group

If the cluster software has been run to set up the cluster, a shared disk group can be created using the following command:

```
# vxdg -s init diskgroup [diskname=]devicename
```

where *diskgroup* is the disk group name, *diskname* is the administrative name chosen for a VM disk, and *devicename* is the device name (or disk access name).

---

**Caution** The operating system cannot tell if a disk is shared. To protect data integrity when dealing with disks that can be accessed by multiple systems, use the correct designation when adding a disk to a disk group. VxVM allows you to add a disk that is not physically shared to a shared disk group if the node where

---

the disk is accessible is the only node in the cluster. However, this means that other nodes cannot join the cluster. Furthermore, if you attempt to add the same disk to different disk groups on two nodes at the same time, the results are undefined. Handle all configuration on one node only.

---

## Setting the Connectivity Policy on a Shared Disk Group

The `vxedit` command may be used to set either the `global` or `local` connectivity policy for a shared disk group:

```
# vxedit -g diskgroup set diskdetpolicy=global|local
```

## Changing the Activation Mode on a Shared Disk Group

The activation mode of a shared disk group can be changed using the following command:

```
# vxdg -g diskgroup set activation=mode
```

where the activation *mode* is one of `exclusivewrite` or `ew`, `readonly` or `ro`, `sharedread` or `sr`, `sharedwrite` or `sw`, or `off`.

## Importing Disk Groups as Shared

Disk groups can be imported as shared using the `vxdg -s import` command. If the disk groups are set up before the cluster software is run, the disk groups can be imported into the cluster arrangement using the following command:

```
# vxdg -s import diskgroup
```

where *diskgroup* is the disk group name or ID. On subsequent cluster restarts, the disk group is automatically imported as shared. Note that it can be necessary to deport the disk group (using the `vxdg deport diskgroup` command) before invoking the `vxdg` utility.

## Converting a Disk Group from Shared to Private

A shared disk group can be converted to private by deporting it and then reimporting it using these commands:

```
# vxdg deport diskgroup  
# vxdg import diskgroup
```



## Forcibly Importing a Disk Group or Adding a Disk

The `vxdbg` command has a force option (`-f`) that can be used to import a disk group forcibly, or to add a disk forcibly to a disk group.

---

**Note** The force option (`-f`) must be used with caution and only if the system administrator is fully aware of the possible consequences.

---

When a cluster is restarted, VxVM can refuse to auto-import a disk group for one of the following reasons:

- ◆ A disk in that disk group is no longer accessible because of hardware errors on the disk. In this case, the system administrator can reimport the disk group with the force option using the following command:
 

```
# vxdbg -s -f import diskgroup
```
- ◆ Some of the nodes to which disks in the disk group are attached are not currently in the cluster, so the disk group cannot access all of its disks. In this case, a forced import is unsafe and must not be attempted because it can result in inconsistent mirrors.

If VxVM does not add a disk to an existing disk group because that disk is not attached to the same nodes as the other disks in the disk group, the system administrator can forcibly add the disk using the following command:

```
# vxdbg -f adddisk -g diskgroup [diskname=]devicename
```

## Listing Shared Disk Groups

`vxdbg` can be used to list information about shared disk groups. To display information for all disk groups, use the following command:

```
# vxdbg list
```

Example output from this command is displayed here:

NAME	STATE	ID
rootdg	enabled	774215886.1025.teal
group2	enabled,shared	774575420.1170.teal
group1	enabled,shared	774222028.1090.teal

Shared disk groups are designated with the flag `shared`.

To display information for shared disk groups only, use the following command:

```
# vxdbg -s list
```

Example output from this command is as follows:

NAME	STATE	ID
group2	enabled,shared	774575420.1170.teal
group1	enabled,shared	774222028.1090.teal

To display information about one specific disk group, use the following command:

```
# vxdg list diskgroup
```

where *diskgroup* is the disk group name.

For example, the output for the command `vxdg list group1` on the master is as follows:

```
Group:      group1
dgid:      774222028.1090.teal
import-id: 32768.1749
flags:     shared
version:   70
activation: exclusive-write
detach-policy: local
copies:    nconfig=default nlog=default
config:    seqno=0.1976 permlen=1456 free=1448 templen=6 loglen=220
config disk c1t0d0s2 copy 1 len=1456 state=clean online
config disk c1t1d0s2 copy 1 len=1456 state=clean online
log disk c1t0d0s2 copy 1 len=220
log disk c1t1d0s2 copy 1 len=220
```

Note that the `flags` field is set to `shared`. The output for the same command when run on a slave is slightly different.

## Creating Volumes with Exclusive Open Access by a Node

When using the `vxassist` command to create a volume, you can use the `exclusive=on` attribute to specify that the volume may only be opened by one node in the cluster at a time. For example, to create the mirrored volume `volmir` and configure it for exclusive open, use the following command:

```
# vxassist make volmir 5g layout=mirror exclusive=on
```

Multiple opens by the same node are also supported. Any attempts by other nodes to open the volume fail until the final close of the volume by the node that opened it.

Specifying `exclusive=off` instead means that more than one node in a cluster can open a volume simultaneously.

## Setting Exclusive Open Access to a Volume by a Node

You can set the `exclusive=on` attribute with the `vxvol` command to specify that an existing volume may only be opened by one node in the cluster at a time.



**Note** Only configure `exclusive open` on an existing volume if none of the nodes in a cluster currently have it open.

---

For example, to set `exclusive open` on the volume `volmir`, use the following command:

```
# vxvol set exclusive=on volmir
```

Multiple opens by the same node are also supported. Any attempts by other nodes to open the volume fail until the final close of the volume by the node that opened it.

Specifying `exclusive=off` instead means that more than one node in a cluster can open a volume simultaneously.

## Other Cluster-related Utilities and Daemons

The following utilities and daemons have been created or modified for use with VxVM in a cluster environment:

- ◆ [vxclust Utility](#)
- ◆ [vxclustadm Utility](#)
- ◆ [vxconfigd Daemon](#)
- ◆ [vxdctl Utility](#)
- ◆ [vxrecover Utility](#)
- ◆ [vxstat Utility](#)

The following sections contain information about how each of these utilities is used in a cluster environment. For further details on any of these utilities, see their manual pages.

### vxclust Utility

---

**Note** `vxclust` works with SunCluster™ as cluster manager.

---

Every time there is a cluster reconfiguration, every node currently in the cluster runs the `vxclust` utility at each of several well-orchestrated steps. Cluster manager facilities ensure that the same step is executed on all nodes at the same time. A given step only starts when the previous one has completed on all nodes. At each step in the reconfiguration, the `vxclust` utility determines what the cluster feature should do next. After informing VxVM of its next action, the `vxclust` utility waits for the outcome (success, failure, or retry) and communicates that to the cluster manager.

If a node does not respond to a the `vxclust` utility request within a specific timeout period, that node aborts. The `vxclust` utility then decides whether to restart the reconfiguration or give up, depending on the circumstances. If the cause of the reconfiguration is a local, uncorrectable error, `vxclust` gives up. If a node cannot complete an operation because another node has left, the surviving node times out. In this case, the `vxclust` utility requests a reconfiguration with the expectation that another node will leave. If no other node leaves, the `vxclust` utility causes the local node to leave.

If a reconfiguration step fails, the `vxclust` utility returns an error to the cluster manager. The cluster manager may decide to abort the node, causing its immediate departure from the cluster. Any I/O in progress to the shared disk fails and access to the shared disks is stopped.

`vxclust` decides what actions to take when it is informed of changes in the cluster. If a new master node is required (due to failure of the previous master), `vxclust` determines which node becomes the new master.

## vxclustadm Utility

---

**Note** `vxclustadm` works only with the VERITAS Cluster Server (VCS).

---

The `vxclustadm` command activates and deactivates cluster functionality of VxVM on a node in the cluster. It is called from online and offline scripts during VCS cluster startup and shutdown.

The `startnode` option passes the cluster configuration information to the VxVM kernel. In response to this command, the kernel and the configuration daemon, `vxconfigd`, perform initialization.

The `stopnode` option stops cluster functionality on a node. It waits for all outstanding I/O to complete and all applications to close shared volumes. The `abortnode` option aborts the clustering activity on a node.

This is an emergency shutdown that aborts all the uncompleted I/O on shared volumes. The `nodestate` option determines the state of a node in the cluster.

Refer to `vxclustadm(1M)` for more information.

## vxconfigd Daemon

The `vxconfigd` daemon is the VxVM configuration daemon. The `vxconfigd` daemon maintains configurations of VxVM objects. The `vxconfigd` daemon receives cluster-related instructions from the `vxclust` utility under SunCluster or the kernel when running VCS. A separate copy of the `vxconfigd` daemon resides on each node;



these copies communicate with each other through networking facilities. For each node in a cluster, VxVM utilities communicate with the `vxconfigd` daemon running on that particular node; utilities do not attempt to connect with `vxconfigd` daemons on other nodes. During startup of the cluster, the `vxclust` utility (SunCluster) or the kernel (VCS) prompts the `vxconfigd` daemon to begin cluster operation and indicates whether it is a master or slave node.

When a node is initialized for cluster operation, the `vxconfigd` daemon is notified that the node is about to join the cluster and is provided with the following information (from the cluster manager configuration database):

- ◆ cluster ID
- ◆ node IDs
- ◆ master node ID
- ◆ role of the node
- ◆ network address of the `vxconfigd` daemon on each node

On the master node, the `vxconfigd` daemon sets up the shared configuration (that is, it imports the shared disk groups) and informs the `vxclust` utility (SunCluster) or the kernel (VCS) when it is ready for slaves to join.

On slave nodes, the `vxconfigd` daemon is notified when the slave node can join the cluster. When the slave node joins the cluster, the `vxconfigd` daemon and the VxVM kernel communicate with their counterparts on the master in order to set up the shared configuration.

When a node leaves the cluster, the `vxconfigd` daemon notifies the kernel on all the other nodes. The master node then performs any necessary cleanup. If the master node leaves the cluster, the kernels choose a new master node and the `vxconfigd` daemons on all nodes are notified of the choice.

The `vxconfigd` daemon also participates in volume reconfiguration. See “[Volume Reconfiguration](#)” on page 198 for information on the role of the `vxconfigd` daemon in volume reconfiguration.

## vxconfigd Daemon Recovery

The `vxconfigd` daemon can be stopped and/or restarted at any time. While the `vxconfigd` daemon is stopped, volume reconfigurations cannot take place and other nodes cannot join the cluster until the `vxconfigd` daemon is restarted. In the cluster, the `vxconfigd` daemons on the slaves are always connected to the `vxconfigd` daemon on the master. It is therefore not advisable to stop the `vxconfigd` daemon on any clustered node.

If the `vxconfigd` daemon is stopped, different actions are taken depending on which node has a stopped daemon:



- ◆ If the `vxconfigd` daemon is stopped on the slaves, the master takes no action. When the `vxconfigd` daemon is restarted on the slave, the slave `vxconfigd` daemon attempts to reconnect to the master daemon and re-acquire the information about the shared configuration. (The kernel view of the shared configuration is unaffected, as is access to the shared disks.) Until the slave `vxconfigd` daemon has successfully rejoined the master, it has very little information about the shared configuration and any attempts to display or modify the shared configuration can fail. In particular, if the shared disk groups are listed (using the `vx dg list` command), they are marked as disabled; when the rejoin completes successfully, they are marked as enabled.
- ◆ If the `vxconfigd` daemon is stopped on the master, the `vxconfigd` daemons on the slaves attempt to rejoin to the master periodically. Rejoin attempts are not successful until the `vxconfigd` daemon is restarted on the master. In this case, information on the slaves' `vxconfigd` daemon about the shared configuration has not been lost, so configuration displays are accurate.
- ◆ If the `vxconfigd` daemon is stopped on both master and slaves, the slaves do not display accurate configuration information until the `vxconfigd` daemon is restarted on both master and slaves, and they have reconnected.

When the `vxclust` utility (SunCluster) or the kernel (VCS) determines that the `vxconfigd` daemon is stopped on a node, `vxclustd` restarts `vxconfigd`.

---

**Note** With VxVM, the `-r` reset option to the `vxconfigd` daemon restarts the `vxconfigd` daemon and creates all states from scratch. This option is not available while a node is in the cluster because it causes the loss of cluster information; if this option is used under these circumstances, the `vxconfigd` daemon does not start.

---

## vxctl Utility

The `vxctl` utility manages some aspects of the `vxconfigd` volume configuration daemon. The `-c` option can be used to request cluster information. To use the `vxctl` utility to determine whether the `vxconfigd` daemon is enabled and/or running, use the following command:

```
# vxctl -c mode
```

Depending on the circumstances, this produces output similar to the following:

```
mode: enabled: cluster active - MASTER
mode: enabled: cluster active - SLAVE
mode: enabled: cluster inactive
mode: enabled: cluster active - role not set
```

---

**Note** If the `vxconfigd` daemon is disabled, no cluster information is displayed.

---



See the `vxdtl(1M)` man page for a complete description of `vxdtl`.

The `vxdtl` utility lists the cluster protocol version and cluster protocol range. After all the nodes in the cluster are updated with the new cluster protocol, update the entire cluster using the following command:

```
# vxdtl upgrade
```

Check the existing cluster protocol version using the following command:

```
# vxdtl protocolversion
Cluster running at protocol 10
```

Display the maximum and minimum cluster protocol version supported by the current VERITAS Volume Manager release using the following command:

```
# vxdtl protocolrange
minprotoversion: 10, maxprotoversion: 20
```

The `vxdtl list` command displays the cluster protocol version running on a node. The `vxdtl list` command produces the following output:

```
Volboot file
version: 3/1
seqno: 0.19
cluster protocol version: 20
hostid: giga
entries:
```

The `vxdtl support` command displays the maximum and minimum protocol version supported by the node and the current protocol version. The following is the output of the `vxdtl support` command:

```
Support information:
vold_vrsn: 11
dg_minimum: 60
dg_maximum: 70
kernel: 10
protocol_minimum: 10
protocol_maximum: 20
protocol_current: 20
```

## vxrecover Utility

The `vxrecover` utility recovers plexes and volumes after disk replacement.

When a node leaves the cluster, it can leave some mirrors in an inconsistent state. The `vxrecover` utility performs recovery on all volumes in this state. The `-c` option causes the `vxrecover` utility to perform recovery for all volumes in cluster-shareable disk groups. The `vxclustd` daemon automatically calls the `vxrecover -c` utility, when necessary.

---

**Note** While the `vxrecover` utility is active, there can be some degradation in system performance.

---

## vxstat Utility

The `vxstat` utility returns statistics for specified objects. In a cluster environment, the `vxstat` utility gathers statistics from all of the nodes in the cluster. The statistics give the total usage, by all nodes, for the requested objects. If a local object is specified, its local usage is returned.

The caller can optionally specify a subset of nodes using the following command:

```
# vxstat -g diskgroup -n node [, node . . . ]
```

where *node* is an integer. If a comma-separated list of nodes is supplied, the `vxstat` utility displays the sum of the statistics for the nodes in the list.

For example, to obtain statistics for node 2, volume `vol1`, use the following command:

```
# vxstat -g group1 -n 2 vol1
```

This command produces output similar to the following:

```

      OPERATIONS  BLOCKS      AVG TIME(ms)
TYP  NAME  READ  WRITE  READ  WRITE  READ  WRITE
vol1 vol1  124210  6000000  99.00.0
```

To obtain and display statistics for the entire cluster, use the following command:

```
# vxstat -b
```

The statistics for all nodes are added together. For example, if node 1 did 100 I/Os and node 2 did 200 I/Os, the `vxstat -b` command returns 300 I/Os.





## Introduction

VERITAS Volume Manager (VxVM) can improve overall system performance by optimizing the layout of data storage on the available hardware. This chapter contains guidelines establishing performance priorities, for monitoring performance, and for configuring your system appropriately.

## Performance Guidelines

VxVM allows you to optimize data storage performance using the following two strategies:

- ◆ Balance the I/O load among the available disk drives.
- ◆ Use striping and mirroring to increase I/O bandwidth to the most frequently accessed data.

VxVM also provides data redundancy (through mirroring and RAID-5) that allows continuous access to data in the event of disk failure.

## Data Assignment

When deciding where to locate file systems, you, as a system administrator, typically attempts to balance I/O load among available disk drives. The effectiveness of this approach is limited by the difficulty of anticipating future usage patterns, as well as the inability to split file systems across drives. For example, if a single file system receives most disk accesses, moving the file system to another drive also moves the bottleneck to that drive.

VxVM can split volumes across multiple drives. This permits you a finer level of granularity when locating data. After measuring actual access patterns, you can adjust your previous decisions on the placement of file systems. You can reconfigure volumes online without adversely impacting their availability.



## Striping

Striping improves access performance by cutting data into slices and storing it on multiple devices that can be accessed in parallel. Striped plexes improve access performance for both read and write operations.

Having identified the most heavily accessed volumes (containing file systems or databases), you can increase access bandwidth to this data by striping it across portions of multiple disks.

The figure “[Use of Striping for Optimal Data Access](#)” shows an example of a single volume (HotVol) that has been identified as a data-access bottleneck. This volume is striped across four disks, leaving the remaining space on these disks free for use by less-heavily used volumes.

Use of Striping for Optimal Data Access

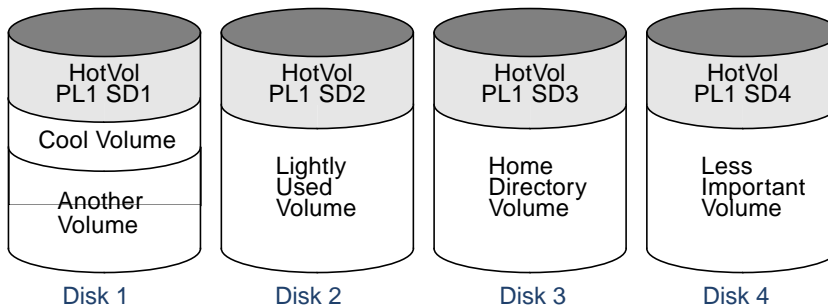

## Mirroring

Mirroring stores multiple copies of data on a system. When properly applied, mirroring provides continuous availability of data and protection against data loss due to physical media failure. Mirroring improves the chance of data recovery in the event of a system crash or the failure of a disk or other hardware.

In some cases, you can also use mirroring to improve I/O performance. Unlike striping, the performance gain depends on the ratio of reads to writes in the disk accesses. If the system workload is primarily write-intensive (for example, greater than 30 percent writes), mirroring can result in reduced performance.

## Combining Mirroring and Striping

Mirroring and striping can be used together to achieve a significant improvement in performance when there are multiple I/O streams.

Striping provides better throughput because parallel I/O streams can operate concurrently on separate devices. Serial access is optimized when I/O exactly fits across all stripe units in one stripe.

Because mirroring is generally used to protect against loss of data due to disk failures, it is often applied to write-intensive workloads which degrades throughput. In such cases, combining mirroring with striping delivers both high availability and increased throughput.

A mirrored-stripe volume may be created by striping half of the available disks to form one striped data plex, and striping the remaining disks to form the other striped data plex in the mirror. This is often the best way to configure a set of disks for optimal performance with reasonable reliability. However, the failure of a single disk in one of the plexes makes the entire plex unavailable.

Alternatively, you can arrange equal numbers of disks into separate mirror volumes, and then create a striped plex across these mirror volumes to form a striped-mirror volume (see “[Mirroring Plus Striping \(Striped-Mirror, RAID-1+0 or RAID-10\)](#)” on page 20). The failure of a single disk in a mirror does not take the disks in the other mirrors out of use. A striped-mirror layout is preferred over a mirrored-stripe layout for large volumes or large numbers of disks.

## RAID-5

RAID-5 offers many of the advantages of combined mirroring and striping, but requires less disk space. RAID-5 read performance is similar to that of striping and RAID-5 parity offers redundancy similar to mirroring. Disadvantages of RAID-5 include relatively slow write performance.

RAID-5 is not usually seen as a way of improving throughput performance except in cases where the access patterns of applications show a high ratio of reads to writes.

## Volume Read Policies

To help optimize performance for different types of volumes, VxVM supports the following read policies on data plexes:



- ◆ `round`—a *round-robin* read policy, where all plexes in the volume take turns satisfying read requests to the volume.
- ◆ `prefer`—a *preferred-plex* read policy, where the plex with the highest performance usually satisfies read requests. If that plex fails, another plex is accessed.
- ◆ `select`—default read policy, where the appropriate read policy for the configuration is selected automatically. For example, `prefer` is selected when there is only one striped plex associated with the volume, and `round` is selected in most other cases.

---

**Note** You cannot set the read policy on a RAID-5 data plex. RAID-5 plexes have their own read policy (RAID).

---

For instructions on how to configure the read policy for a volume's data plexes, see [“Changing the Read Policy for Mirrored Volumes”](#) on page 153.

In the configuration example shown in the figure [“Use of Mirroring and Striping for Improved Performance,”](#) the read policy of the mirrored-stripe volume labeled `HotVol` is set to `prefer` for the striped plex `PL1`. This policy causes distributes the load when reading across the otherwise lightly-used disks in `PL1`, as opposed to the single disk in plex `PL2`. (`HotVol` is an example of a mirrored-stripe volume in which one data plex is striped and the other data plex is concatenated.)

Use of Mirroring and Striping for Improved Performance

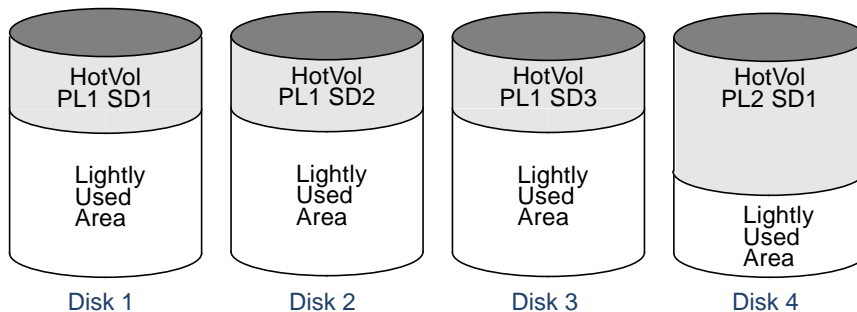

---

**Note** To improve performance for read-intensive workloads, you can attach up to 32 data plexes to the same volume. However, this would usually be an ineffective use of disk space for the gain in read performance.

---



## Performance Monitoring

As a system administrator, you have two sets of priorities for setting priorities for performance. One set is *physical*, concerned with hardware such as disks and controllers. The other set is *logical*, concerned with managing software and its operation.

### Setting Performance Priorities

The important physical performance characteristics of disk hardware are the relative amounts of I/O on each drive, and the concentration of the I/O within a drive to minimize seek time. Based on monitored results, you can then move the location of subdisks to balance I/O activity across the disks.

The logical priorities involve software operations and how they are managed. Based on monitoring, you may choose to change the layout of certain volumes to improve their performance. You might even choose to reduce overall throughput to improve the performance of certain critical volumes. Only you can decide what is important on your system and what tradeoffs you need to make.

Best performance is usually achieved by striping and mirroring all volumes across a reasonable number of disks and mirroring between controllers, when possible. This procedure tends to even out the load between all disks, but it can make VxVM more difficult to administer. For large numbers of disks (hundreds or thousands), set up disk groups containing 10 disks, where each group is used to create a striped-mirror volume. This technique provides good performance while easing the task of administration.

### Obtaining Performance Data

VxVM provides two types of performance information: I/O statistics and I/O traces. Each of these can help in performance monitoring. You can obtain I/O statistics using the `vxstat` command, and I/O traces using the `vxtrace` command. A brief discussion of each of these utilities may be found in the following sections.

#### Tracing Volume Operations

Use the `vxtrace` command to trace operations on specified volumes, kernel I/O object types or devices. The `vxtrace` command either prints kernel I/O errors or I/O trace records to the standard output or writes the records to a file in binary format. Binary trace records written to a file can also be read back and formatted by `vxtrace`.



If you do not specify any operands, `vxtrace` reports either all error trace data or all I/O trace data on all virtual disk devices. With error trace data, you can select all accumulated error trace data, wait for new error trace data, or both of these (this is the default action). Selection can be limited to a specific disk group, to specific VxVM kernel I/O object types, or to particular named objects or devices.

For detailed information about how to use `vxtrace`, refer to the `vxtrace(1M)` manual page.

## Printing Volume Statistics

Use the `vxstat` command to access information about activity on volumes, plexes, subdisks, and disks under VxVM control, and to print summary statistics to the standard output. These statistics represent VxVM activity from the time the system initially booted or from the last time the counters were reset to zero. If no VxVM object name is specified, statistics from all volumes in the configuration database are reported.

VxVM records the following I/O statistics:

- ◆ count of operations
- ◆ number of blocks transferred (one operation can involve more than one block)
- ◆ average operation time (which reflects the total time through the VxVM interface and is not suitable for comparison against other statistics programs)

VxVM records the preceding I/O statistics for logical I/Os. The statistics include reads, writes, atomic copies, verified reads, verified writes, plex reads, and plex writes for each volume. As a result, one write to a two-plex volume results in at least five operations: one for each plex, one for each subdisk, and one for the volume. Also, one read that spans two subdisks shows at least four reads—one read for each subdisk, one for the plex, and one for the volume.

VxVM also maintains other statistical data. For each plex, read failures and write failures are maintained. For volumes, corrected read failures and write failures accompany the read failures and write failures.

To reset the statistics information to zero, use the `-r` option. This can be done for all objects or for only those objects that are specified. Resetting just prior to an operation makes it possible to measure the impact of that particular operation.

The following is an example of output produced using the `vxstat` command:

OPERATIONS		BLOCKS		AVG TIME(ms)			
TYP	NAME	READ	WRITE	READ	WRITE	READ	WRITE
vol	blop	0	0	0	0	0.0	0.0
vol	foobarvol	0	0	0	0	0.0	0.0
vol	rootvol	73017	181735	718528	1114227	26.8	27.9
vol	swapvol	13197	20252	105569	162009	25.8	397.0
vol	testvol	0	0	0	0	0.0	0.0

Additional volume statistics are available for RAID-5 configurations.

For detailed information about how to use `vxstat`, refer to the `vxstat(1M)` manual page.

## Using Performance Data

When you have gathered performance data, you can use it to determine how to configure your system to use resources most effectively. The following sections provide an overview of how you can use this data.

### Using I/O Statistics

Examination of the I/O statistics can suggest how to reconfigure your system. You should examine two primary statistics: volume I/O activity and disk I/O activity.

Before obtaining statistics, reset the counters for all existing statistics using the `vxstat -r` command. This eliminates any differences between volumes or disks due to volumes being created, and also removes statistics from boot time (which are not usually of interest).

After resetting the counters, allow the system to run during typical system activity. Run the application or workload of interest on the system to measure its effect. When monitoring a system that is used for multiple purposes, try not to exercise any one application more than usual. When monitoring a time-sharing system with many users, let statistics accumulate for several hours during the normal working day.

To display volume statistics, enter the `vxstat` command with no arguments. The following is a typical display of volume statistics:

OPERATIONS		BLOCKS		AVG TIME(ms)			
TYP	NAME	READ	WRITE	READ	WRITE	READ	WRITE
vol	archive	865	807	5722	3809	32.5	24.0
vol	home	2980	5287	6504	10550	37.7	221.1
vol	local	49477	49230	507892	204975	28.5	33.5
vol	rootvol	102906	342664	1085520	1962946	28.1	25.6
vol	src	79174	23603	425472	139302	22.4	30.9
vol	swapvol	22751	32364	182001	258905	25.3	323.2



Such output helps to identify volumes with an unusually large number of operations or excessive read or write times.

To display disk statistics, use the `vxstat -d` command. The following is a typical display of disk statistics:

TYP	NAME	OPERATIONS		BLOCKS		AVG TIME (ms)	
		READ	WRITE	READ	WRITE	READ	WRITE
dm	disk01	40473	174045	455898	951379	29.5	35.4
dm	disk02	32668	16873	470337	351351	35.2	102.9
dm	disk03	55249	60043	780779	731979	35.3	61.2
dm	disk04	11909	13745	114508	128605	25.0	30.7

If the you need to move the volume named `archive` onto another disk, use the following command to identify on which disks it lies:

```
# vxprint -tvh archive
```

The following is a typical display:

V	NAME	SETYPE	STATE	STATE	LENGTH	READPOL	REFPLEX
PL	NAME	VOLUMEK	STATE	STATE	LENGTH	LAYOUT	NCOL/WDTH MODE
SD	NAME	PLEX	PLOFFS	DISKOFFSLENGTH	[COL/]	OFF	FLAGS
v	archive	fsgen	ENABLED	ACTIVE	20480	0	SELECT -
pl	archive-01	archive	ENABLED	ACTIVE	20480	0	CONCAT RW
sd	disk03-03	archive-010		409600	20480	0/0	c1t2d0

**Note** Your system may use a *device name* that differs from the examples. For more information on device names, see “[Administering Disks](#)” on page 43.

The subdisks line (beginning `sd`) indicates that the `archive` volume is on disk `disk03`. To move the volume off `disk03`, use the following command:

```
# vxassist move archive !disk03 dest_disk
```

where *dest\_disk* is the disk to which you want to move the volume. It is not necessary to specify a *dest\_disk*. If you do not specify a *dest\_disk*, the volume is moved to an available disk with enough space to contain the volume.

For example, to move the volume from `disk03` to `disk04`, use the following command:

```
# vxassist move archive !disk03 disk04
```

This command indicates that the volume is to be reorganized so that no part remains on `disk03`.

**Note** The graphical user interface (GUI) provides an easy way to move pieces of volumes between disks and may be preferable to using the command line.

If two volumes (other than the root volume) on the same disk are busy, move them so that each is on a different disk.

If one volume is particularly busy (especially if it has unusually large average read or write times), stripe the volume (or split the volume into multiple pieces, with each piece on a different disk). If done online, converting a volume to use striping requires sufficient free space to store an extra copy of the volume. If sufficient free space is not available, a backup copy can be made instead. To convert a volume, create a striped plex as a mirror of the volume and then remove the old plex. For example, the following commands stripe the volume `archive` across disks `disk02`, `disk03`, and `disk04`, and then remove the original plex `archive-01`:

```
# vxassist mirror archive layout=stripe disk02 disk03 disk04
# vxplex -o rm dis archive-01
```

After reorganizing any particularly busy volumes, check the disk statistics. If some volumes have been reorganized, clear statistics first and then accumulate statistics for a reasonable period of time.

If some disks appear to be excessively busy (or have particularly long read or write times), you may want to reconfigure some volumes. If there are two relatively busy volumes on a disk, move them closer together to reduce seek times on the disk. If there are too many relatively busy volumes on one disk, move them to a disk that is less busy.

Use I/O tracing (or subdisk statistics) to determine whether volumes have excessive activity in particular regions of the volume. If the active regions can be identified, split the subdisks in the volume and move those regions to a less busy disk.

---

**Caution** Striping a volume, or splitting a volume across multiple disks, increases the chance that a disk failure results in failure of that volume. For example, if five volumes are striped across the same five disks, then failure of any one of the five disks requires that all five volumes be restored from a backup. If each volume were on a separate disk, only one volume would need to be restored. Use mirroring or RAID-5 to reduce the chance that a single disk failure results in failure of a large number of volumes.

---

Note that file systems and databases typically shift their use of allocated space over time, so this position-specific information on a volume is often not useful. Databases are reasonable candidates for moving to non-busy disks if the space used by a particularly busy index or table can be identified.

Examining the ratio of reads to writes helps to identify volumes that can be mirrored to improve their performance. If the read-to-write ratio is high, mirroring can increase performance as well as reliability. The ratio of reads to writes where mirroring can improve performance depends greatly on the disks, the disk controller, whether multiple controllers can be used, and the speed of the system bus. If a particularly busy volume has a high ratio of reads to writes, it is likely that mirroring can significantly improve performance of that volume.



### Using I/O Tracing

I/O statistics provide the data for basic performance analysis; I/O traces serve for more detailed analysis. With an I/O trace, focus is narrowed to obtain an event trace for a specific workload. This helps to explicitly identify the location and size of a hot spot, as well as which application is causing it.

Using data from I/O traces, real work loads on disks can be simulated and the results traced. By using these statistics, you can anticipate system limitations and plan for additional resources.

## Tuning VxVM

This section describes the mechanisms for controlling the resources used by VxVM. Adjustments can be required for some of the tunable values to obtain best performance (depending on the type of system resources available).

### General Tuning Guidelines

VxVM is tuned for most configurations ranging from small systems to larger servers. In cases where tuning can be used to increase performance on larger systems at the expense of a valuable resource (such as memory), VxVM is generally tuned to run on the smallest supported configuration. Any tuning changes must be performed with care, as they may adversely affect overall system performance or may even leave VxVM unusable.

Various mechanisms exist for tuning VxVM. On some systems, many parameters can be tuned using the global tunable file `/etc/system`. Other values can only be tuned using the command line interface to VxVM.

### Tuning for Large Systems

On smaller systems (with less than a hundred disk drives), tuning is unnecessary and VxVM is capable of adopting reasonable defaults for all configuration parameters. On larger systems, configurations can require additional control over the tuning of these parameters, both for capacity and performance reasons.

Generally, only a few significant decisions must be made when setting up VxVM on a large system. One is to decide on the size of the disk groups and the number of configuration copies to maintain for each disk group. Another is to choose the size of the private region for all the disks in a disk group.

Larger disk groups have the advantage of providing a larger free-space pool for the `vxassist(1M)` command to select from, and also allow for the creation of larger arrays. Smaller disk groups do not require as large a configuration database and so can exist with

smaller private regions. Very large disk groups can eventually exhaust the private region size in the disk group with the result that no more configuration objects can be added to that disk group. At that point, the configuration either has to be split into multiple disk groups, or the private regions have to be enlarged. This involves re-initializing each disk in the disk group (and can involve reconfiguring everything and restoring from backup).

A general recommendation for users of disk array subsystems is to create a single disk group for each array so the disk group can be physically moved as a unit between systems.

## Number of Configuration Copies for a Disk Group

Selection of the number of configuration copies for a disk group is based on the trade-off between redundancy and performance. As a general rule, the fewer configuration copies that exist in a disk group, the quicker the group can be initially accessed, the faster the initial start of the `vxconfigd` daemon can proceed, and the quicker transactions can be performed on the disk group.

---

**Caution** The risk of lower redundancy of the database copies is the loss of the configuration database. Loss of the database results in the loss of all objects in the database and all data contained in the disk group.

---

The default policy for configuration copies in the disk group is to allocate a configuration copy for each controller identified in the disk group, or for each target containing multiple addressable disks on the same target. This is sufficient from the redundancy perspective, but can lead to large numbers of configuration copies under some circumstances.

If this is the case, it is recommended to limit the number of configuration copies to a minimum of 4. The location of the copies is selected as before, according to maximal controller or target spread.

The mechanism for setting the number of copies for a disk group is to use the `vx dg init` command for a new group setup (see the `vx dg(1M)` manual page for details). Also, you can change copies of an existing group by using the `vxedit set` command (see the `vxedit(1M)` manual page for details). For example, to set the disk group called `foodg` to contain 5 copies, use the following command:

```
# vxedit set nconfig=5 foodg
```

## Changing Values of Tunables

Tunables can be modified by adding the appropriate lines to the `/etc/system` file and then rebooting the system.



For example, to change the value of `vol_tunable` to 5000, add the following line into the VxVM section (delimited by `vxvm_START` and `vxvm_END` comments) in the `/etc/system` file:

```
* vxvm_START (do not remove)
...
set vxio:vol_tunable=5000
...
* vxvm_END (do not remove)
```

## Tunables

The following sections describe specific tunables.

### **vol\_checkpt\_default**

The interval at which utilities performing recoveries or resynchronization operations load the current offset into the kernel as a checkpoint. A system failure during such operations does not require a full recovery, but can continue from the last reached checkpoint.

The default value of the checkpoint is 20480 sectors (10MB).

Increasing this size reduces the overhead of checkpointing on recovery operations at the expense of additional recovery following a system failure during a recovery.

### **vol\_default\_iodelay**

The count in clock ticks for which utilities pause if they have been directed to reduce the frequency of issuing I/O requests, but have not been given a specific delay time. This tunable is used by utilities performing operations such as resynchronizing mirrors or rebuilding RAID-5 columns.

The default for this tunable is 50 ticks.

Increasing this value results in slower recovery operations and consequently lower system impact while recoveries are being performed.

### **vol\_fmr\_logsz**

The maximum size in kilobytes of the bitmap that FastResync uses to track changed blocks in a volume. The number of blocks in a volume that are mapped to each bit in the bitmap depends on the size of the volume, and this value changes if the size of the



volume is changed. For example, if the volume size is 1 gigabyte and the system block size is 512 bytes, a `vol_fm_r_logsz` value of 4 yields a map contains 32,768 bits, each bit representing one region of 64 blocks.

The larger is the bitmap size, the fewer the number of blocks that are mapped to each bit. This can reduce the amount of reading and writing required on resynchronization, at the expense of requiring more non-pagable kernel memory for the bitmap. Additionally, on clustered systems, a larger bitmap size increases the latency in I/O performance, and it also increases the load on the private network between the cluster members. This is because every other member of the cluster must be informed each time a bit in the map is marked.

The total memory overhead is one accumulator bitmap plus one bitmap for each mirror or snapshot that is tracked by FastResync. In configurations which have thousands of mirrors with attached snapshot plexes, this can represent a significantly higher overhead in memory consumption than is usual for VxVM.

The default value of this tunable is 4 KB. The maximum and minimum permitted values are 1 and 8 KB.

### **vol\_max\_vol**

The maximum number of volumes that can be created on the system. This value can be set to between 1 and the maximum number of minor numbers representable in the system.

The default value for this tunable is 131071.

### **vol\_maxio**

The maximum size of logical I/O operations that can be performed without breaking up the request. I/O requests to VxVM that are larger than this value are broken up and performed synchronously. Physical I/O requests are broken up based on the capabilities of the disk device and are unaffected by changes to this maximum logical request limit.

The default value for this tunable is 512 sectors (256K).



## vol\_maxioctl

The maximum size of data that can be passed into VxVM via an `ioctl` call. Increasing this limit allows larger operations to be performed. Decreasing the limit is not generally recommended, because some utilities depend upon performing operations of a certain size and can fail unexpectedly if they issue oversized `ioctl` requests.

The default value for this tunable is 32768 bytes (32KB).

## vol\_maxkiocount

The maximum number of I/O operations that can be performed by VxVM in parallel. Additional I/O requests that attempt to use a volume device are queued until the current activity count drops below this value.

The default value for this tunable is 2048.

Because most process threads can only issue a single I/O request at a time, reaching the limit of active I/O requests in the kernel requires 2048 I/O operations to be performed in parallel. Raising this limit seems unlikely to provide much benefit except on the largest of systems.

## vol\_maxparallelio

The number of I/O operations that the `vxconfigd(1M)` daemon is permitted to request from the kernel in a single `VOL_VOLDIO_READ` per `VOL_VOLDIO_WRITE` `ioctl` call.

The default value for this tunable is 256. It is not desirable to change this value.

## vol\_maxspecialio

The maximum size of an I/O request that can be issued by an `ioctl` call. Although the `ioctl` request itself can be small, it can request a large I/O request be performed. This tunable limits the size of these I/O requests. If necessary, a request that exceeds this value can be failed, or the request can be broken up and performed synchronously.

The default value for this tunable is 512 sectors (256KB).

Raising this limit can cause difficulties if the size of an I/O request causes the process to take more memory or kernel virtual mapping space than exists and thus deadlock. The maximum limit for `vol_maxio` is 20% of the smaller of physical memory or kernel virtual memory. It is inadvisable to go over this limit, because deadlock is likely to occur.

If stripes are larger than `vol_maxio`, full stripe I/O requests are broken up, which prevents full-stripe read/writes. This throttles the volume I/O throughput for sequential I/O or larger I/O requests.

This tunable limits the size of an I/O request at a higher level in VxVM than the level of an individual disk. For example, for an 8 by 64KB stripe, the 256KB value only allows I/O requests that use half the disks in the stripe; thus, it cuts potential throughput in half. If you have more columns or you have used a larger interleave factor, then your relative performance is worse.

This tunable must be set, as a minimum, to the size of your largest stripe (RAID-0 or RAID-5).

### **vol\_mvr\_maxround**

The granularity of the round-robin policy for reading from mirrors. A read is serviced by the same mirror as the last read if its offset is within the number of sectors described by this tunable of the last read.

The default for this value is 512 sectors (256KB).

Increasing this value causes fewer switches to alternate mirrors for reading. This is desirable if the I/O being performed is largely sequential with a few small seeks between I/O operations. Large numbers of randomly distributed volume reads are generally best served by reading from alternate mirrors.

### **vol\_subdisk\_num**

The maximum number of subdisks that can be attached to a single plex. There is no theoretical limit to this number, but it has been limited to a default value of 4096. This default can be changed, if required.

### **voldrl\_max\_drtregs**

The maximum number of dirty regions that can exist on the system at any time. This is a global value applied to the entire system, regardless of how many active volumes the system has.

The default value for this tunable is 2048.

The tunable `voldrl_max_drtregs` can be used to regulate the worse-case recovery time for the system following a failure. A larger value may result in improved system performance at the expense of recovery time.



## **voldrl\_max\_seq\_dirty**

The maximum number of dirty regions allowed for sequential DRL. This is useful for volumes that are usually written to sequentially, such as database logs. Limiting the number of dirty regions allows for faster recovery if a crash occurs.

The default value for this tunable is 3.

## **voldrl\_min\_regionsz**

The minimum number of sectors for a dirty region logging (DRL) volume region. With DRL, VxVM logically divides a volume into a set of consecutive regions. Larger region sizes tend to cause the cache hit-ratio for regions to improve. This improves the write performance, but it also prolongs the recovery time.

The VxVM kernel currently sets the default value for this tunable to 1024 sectors.

## **voliomem\_chunk\_size**

The granularity of memory chunks used by VxVM when allocating or releasing system memory. A larger granularity reduces CPU overhead due to memory allocation by allowing VxVM to retain hold of a larger amount of memory.

The default size for this tunable is 64KB.

## **voliomem\_maxpool\_sz**

The maximum memory requested from the system by VxVM for internal purposes. This tunable has a direct impact on the performance of VxVM as it prevents one I/O operation from using all the memory in the system.

VxVM allocates two pools of `voliomem_maxpool_sz`, one for RAID-5 and one for mirrored volumes.

A write request to a RAID-5 volume that is greater than `volio_maxpool_sz/10` is broken up and performed in chunks of size `volio_maxpool_sz/10`.

A write request to a mirrored volume that is greater than `volio_maxpool_sz/2` is broken up and performed in chunks of size `volio_maxpool_sz/2`.

The default value for this tunable is 4M.

## **voliot\_errbuf\_default**

The default size of the buffer maintained for error tracing events. This buffer is allocated at driver load time and is not adjustable for size while VxVM is running.

The default size for this buffer is 16384 bytes (16KB).

Increasing this buffer can provide storage for more error events at the expense of system memory. Decreasing the size of the buffer can result in an error not being detected via the tracing device. Applications that depend on error tracing to perform some responsive action are dependent on this buffer.

### **voliot\_iobuf\_dflt**

The default size for the creation of a tracing buffer in the absence of any other specification of desired kernel buffer size as part of the trace `ioctl`.

The default size of this tunable is 8192 bytes (8KB).

If trace data is often being lost due to this buffer size being too small, then this value can be tuned to a more generous amount.

### **voliot\_iobuf\_limit**

The upper limit to the size of memory that can be used for storing tracing buffers in the kernel. Tracing buffers are used by the VxVM kernel to store the tracing event records. As trace buffers are requested to be stored in the kernel, the memory for them is drawn from this pool.

Increasing this size can allow additional tracing to be performed at the expense of system memory usage. Setting this value to a size greater than can readily be accommodated on the system is inadvisable.

The default value for this tunable is 131072 bytes (128KB).

### **voliot\_iobuf\_max**

The maximum buffer size that can be used for a single trace buffer. Requests of a buffer larger than this size are silently truncated to this size. A request for a maximal buffer size from the tracing interface results (subject to limits of usage) in a buffer of this size.

The default size for this buffer is 65536 bytes (64KB).

Increasing this buffer can provide for larger traces to be taken without loss for very heavily used volumes. Care should be taken not to increase this value above the value for the `voliot_iobuf_limit` tunable value.



### **voliot\_max\_open**

The maximum number of tracing channels that can be open simultaneously. Tracing channels are clone entry points into the tracing device driver. Each running `vxtrace` command on the system consumes a single trace channel.

The default number of channels is 32. The allocation of each channel takes up approximately 20 bytes even when not in use.

### **volraid\_rsrtransmax**

The maximum number of transient reconstruct operations that can be performed in parallel for RAID-5. A transient reconstruct operation is one that occurs on a non-degraded RAID-5 volume that has not been predicted. Limiting the number of these operations that can occur simultaneously removes the possibility of flooding the system with many reconstruct operations, and so reduces the risk of causing memory starvation.

The default number of transient reconstruct operations that can be performed in parallel is 1.

Increasing this size improves the initial performance on the system when a failure first occurs and before a detach of a failing object is performed, but can lead to memory starvation.

# Commands Summary

# A

This appendix summarizes the usage and purpose of important commands in VERITAS Volume Manager (VxVM). References are included to longer descriptions in the remainder of this book. For detailed information about an individual command, refer to the appropriate manual page in the 1M section.

## Obtaining Information About Objects in VxVM

Command	Description
<code>vxdisk list [diskname]</code>	List disks under control of VxVM. See <a href="#">“Displaying Disk Information”</a> on page 69.
<code>vx dg list [diskgroup]</code>	List information about disk groups. See <a href="#">“Displaying Disk Group Information”</a> on page 95.
<code>vx dg -s list</code>	List information about shared disk groups in a cluster. See <a href="#">“Listing Shared Disk Groups”</a> on page 210.
<code>vxinfo [-g diskgroup] [volume ...]</code>	Display information about the accessibility and usability of volumes. See <a href="#">“Stopping a Volume”</a> on page 143.
<code>vxprint -hrt [object]</code>	Print single-line information about objects in VxVM. See <a href="#">“Displaying Volume Information”</a> on page 137.
<code>vxprint -st [subdisk]</code>	Display information about subdisks. See <a href="#">“Displaying Subdisk Information”</a> on page 102.
<code>vxprint -pt [plex]</code>	Display information about plexes. See <a href="#">“Displaying Plex Information”</a> on page 110.



---

## Administering Disks

---

Command	Description
<code>vxdiskadm</code>	Administer disks in VxVM using a menu-based interface.
<code>vxdiskadd [devicename]</code>	Add a disk specified by device name. See <a href="#">“Using vxdiskadd to Place a Disk Under Control of VxVM”</a> on page 51.
<code>vxedit rename <i>olddisk newdisk</i></code>	Rename a disk under control of VxVM. See <a href="#">“Renaming a Disk”</a> on page 68.
<code>vxedit set reserve=on off <i>diskname</i></code>	Set aside/do not set aside a disk from use in a disk group. See <a href="#">“Reserving Disks”</a> on page 68.
<code>vxedit set nohotuse=on off <i>diskname</i></code>	Do not/do allow free space on a disk to be used for hot-relocation. See <a href="#">“Excluding a Disk from Hot-Relocation Use”</a> on page 175 and <a href="#">“Making a Disk Available for Hot-Relocation Use”</a> on page 175.
<code>vxedit set spare=on off <i>diskname</i></code>	Add/remove a disk from the pool of hot-relocation spares. See <a href="#">“Marking a Disk as a Hot-Relocation Spare”</a> on page 173 and <a href="#">“Removing a Disk from Use as a Hot-Relocation Spare”</a> on page 174.
<code>vxdisk offline <i>devicename</i></code>	Take a disk offline. See <a href="#">“Taking a Disk Offline”</a> on page 67.
<code>vx dg -g <i>diskgroup</i> rmdisk <i>diskname</i></code>	Remove a disk from its disk group. See <a href="#">“Removing a Disk with No Subdisks”</a> on page 62.
<code>vxdisk rm <i>diskname</i></code>	Remove a disk from control of VxVM. See <a href="#">“Removing a Disk with No Subdisks”</a> on page 62.

---





---

## Creating and Administering Disk Groups

---

Command	Description
<code>vxdg init <i>diskgroup</i></code> <code>[ <i>diskname=</i> ] <i>devicename</i></code>	Create a disk group using a pre-initialized disk. See <a href="#">“Creating a Disk Group”</a> on page 84.
<code>vxdg -s init <i>diskgroup</i> \</code> <code>[ <i>diskname=</i> ] <i>devicename</i></code>	Create a shared disk group in a cluster using a pre-initialized disk. See <a href="#">“Creating a Shared Disk Group”</a> on page 208.
<code>vxdg [-n <i>newname</i>] deport <i>diskgroup</i></code>	Deport a disk group and optionally rename it. See <a href="#">“Deporting a Disk Group”</a> on page 87.
<code>vxdg [-n <i>newname</i>] import <i>diskgroup</i></code>	Import a disk group and optionally rename it. See <a href="#">“Importing a Disk Group”</a> on page 88.
<code>vxdg [-n <i>newname</i>] -s import <i>diskgroup</i></code>	Import a disk group as shared by a cluster, and optionally rename it. See <a href="#">“Importing Disk Groups as Shared”</a> on page 209.
<code>vxdg -g <i>diskgroup</i> set \</code> <code>activation=<i>ew ro sw off</i></code>	Set the activation mode of a shared disk group in a cluster. See <a href="#">“Changing the Activation Mode on a Shared Disk Group”</a> on page 209.
<code>vxrecover -g <i>diskgroup</i> -sb</code>	Start all volumes in an imported disk group. See <a href="#">“Moving Disk Groups Between Systems”</a> on page 92.
<code>vxdg destroy <i>diskgroup</i></code>	Destroy a disk group and release its disks. See <a href="#">“Destroying a Disk Group”</a> on page 95.

---



---

## Creating and Administering Subdisks

---

Command	Description
<code>vxmake sd <i>subdisk diskname,offset,length</i></code>	Create a subdisk. See “ <a href="#">Creating Subdisks</a> ” on page 101.
<code>vxsd assoc <i>plex subdisk ...</i></code>	Associate subdisks with an existing plex. See “ <a href="#">Associating Subdisks with Plexes</a> ” on page 104.
<code>vxsd assoc <i>plex subdisk1:0 ... subdiskM:N-1</i></code>	Add subdisks to the ends of the columns in a striped or RAID-5 volume. See “ <a href="#">Associating Subdisks with Plexes</a> ” on page 104.
<code>vxsd aslog <i>plex subdisk</i></code>	Associate a log subdisk with an exiting plex. See “ <a href="#">Associating Subdisks with Plexes</a> ” on page 104.
<code>vxsd mv <i>oldsubdisk newsubdisk</i></code>	Replace a subdisk. See “ <a href="#">Moving Subdisks</a> ” on page 102.
<code>vxsd -s <i>size split subdisk sd1 sd2</i></code>	Split a subdisk in two. See “ <a href="#">Splitting Subdisks</a> ” on page 103.
<code>vxsd split <i>sd1 sd2 subdisk</i></code>	Join two subdisks. See “ <a href="#">Joining Subdisks</a> ” on page 103.
<code>vxassist [-g <i>diskgroup</i>] move \</code> <code><i>volume !olddisk newdisk</i></code>	Relocate subdisks in a volume between disks. See “ <a href="#">Moving and Unrelocating subdisks using vxassist</a> ” on page 178.
<code>vxunreloc [-g <i>diskgroup</i>] <i>original_disk</i></code>	Relocate subdisks to their original disks. See “ <a href="#">Moving and Unrelocating Subdisks using vxunreloc</a> ” on page 179
<code>vxsd dis <i>subdisk</i></code>	Dissociate a subdisk from a plex. See “ <a href="#">Dissociating Subdisks from Plexes</a> ” on page 106.
<code>vxedit rm <i>subdisk</i></code>	Remove a subdisk. See “ <a href="#">Removing Subdisks</a> ” on page 106.
<code>vxsd -o rm dis <i>subdisk</i></code>	Dissociate and remove a subdisk from a plex. See “ <a href="#">Dissociating Subdisks from Plexes</a> ” on page 106.

---

---

## Creating and Administering Plexes

---

Command	Description
<code>vxmake plex <i>plex</i> \ sd=<i>subdisk1</i>[ , <i>subdisk2</i>, ...]</code>	Create a concatenated plex. See “ <a href="#">Creating Plexes</a> ” on page 109.
<code>vxmake plex <i>plex</i> \ layout=<i>stripe</i> <i>raid5</i> stwidth=<i>W</i> ncolumn=<i>N</i> \ sd=<i>subdisk1</i>[ , <i>subdisk2</i>, ...]</code>	Create a striped or RAID-5 plex. See “ <a href="#">Creating a Striped Plex</a> ” on page 110.
<code>vxplex att <i>volume plex</i></code>	Attach a plex to an existing volume. See “ <a href="#">Attaching and Associating Plexes</a> ” on page 115 and “ <a href="#">Reattaching Plexes</a> ” on page 116.
<code>vxplex det <i>plex</i></code>	Detach a plex. See “ <a href="#">Detaching Plexes</a> ” on page 116.
<code>vxplex off <i>plex</i></code>	Take a plex offline for maintenance. See “ <a href="#">Taking Plexes Offline</a> ” on page 115.
<code>vxmend on <i>plex</i></code>	Re-enable a plex for use. See “ <a href="#">Reattaching Plexes</a> ” on page 116.
<code>vxplex mv <i>oldplex newplex</i></code>	Replace a plex. See “ <a href="#">Moving Plexes</a> ” on page 117.
<code>vxplex cp <i>volume newplex</i></code>	Copy a volume onto a plex. See “ <a href="#">Copying Plexes</a> ” on page 118.
<code>vxplex fix clean <i>plex</i></code>	Set the state of a plex in an unstartable volume to CLEAN. See “ <a href="#">Reattaching Plexes</a> ” on page 116.
<code>vxplex -o rm dis <i>plex</i></code>	Dissociate and remove a plex from a volume. See “ <a href="#">Dissociating and Removing Plexes</a> ” on page 118.

---



---

## Creating Volumes

---

Command	Description
<code>vxassist [-g <i>diskgroup</i>] maxsize \ layout=<i>layout</i> [<i>attributes</i>]</code>	Display the maximum size of volume that can be created. See <a href="#">“Discovering the Maximum Size of a Volume”</a> on page 127.
<code>vxassist make <i>volume length</i> \ [layout=<i>layout</i>] [<i>attributes</i>]</code>	Create a volume. See <a href="#">“Creating a Volume on Any Disk”</a> on page 127 and <a href="#">“Creating a Volume on Specific Disks”</a> on page 128
<code>vxassist make <i>volume length</i> \ layout=mirror [nmirror=<i>N</i>] [<i>attributes</i>]</code>	Create a mirrored volume. See <a href="#">“Creating a Mirrored Volume”</a> on page 129.
<code>vxassist make <i>volume length</i> \ layout=<i>layout</i> exclusive=on [<i>attributes</i>]</code>	Create a volume that may be opened exclusively by a single node in a cluster. See <a href="#">“Creating Volumes with Exclusive Open Access by a Node”</a> on page 211.
<code>vxassist make <i>volume length</i> \ layout=stripe raid5 \ [stripeunit=<i>W</i>] [ncol=<i>N</i>] [<i>attributes</i>]</code>	Create a striped or RAID-5 volume. See <a href="#">“Creating a Striped Volume”</a> on page 130 and <a href="#">“Creating a RAID-5 Volume”</a> on page 132.
<code>vxassist make <i>volume length</i> \ layout=<i>layout</i> mirror=ctlr [<i>attributes</i>]</code>	Create a volume with mirrored data plexes on separate controllers. See <a href="#">“Mirroring across Targets or Controllers”</a> on page 132.
<code>vxmake -U<i>usage_type</i> vol <i>volume</i> \ [len=<i>length</i>] plex=<i>plex</i>,...</code>	Create a volume from existing plexes. See <a href="#">“Creating a Volume using vxmake”</a> on page 133.
<code>vxvol start <i>volume</i></code>	Initialize and start a volume for use. See <a href="#">“Initializing a Volume”</a> on page 136 and <a href="#">“Starting a Volume”</a> on page 144.
<code>vxvol init zero <i>volume</i></code>	Initialize and zero out a volume for use. See <a href="#">“Initializing a Volume”</a> on page 136.

---

---

## Administering Volumes

---

Command	Description
<code>vxassist mirror <i>volume</i> [<i>attributes</i>]</code>	Add a mirror to a volume. See <a href="#">“Adding a Mirror to a Volume”</a> on page 144.
<code>vxassist remove mirror <i>volume</i> [<i>attributes</i>]</code>	Remove a mirror from a volume. See <a href="#">“Removing a Mirror”</a> on page 146.
<code>xassist addlog <i>volume</i> [<i>attributes</i>]</code>	Add a log to a volume. See <a href="#">“Adding a DRL Log to a Mirrored Volume”</a> on page 147 and <a href="#">“Adding a RAID-5 Log”</a> on page 148.
<code>xassist remove log <i>volume</i> [<i>attributes</i>]</code>	Remove a log from a volume. See <a href="#">“Removing a DRL Log”</a> on page 147 and <a href="#">“Removing a RAID-5 Log”</a> on page 148.
<code>vxvol set fastresync=on off <i>volume</i></code>	Turn FastResync on or off for a volume. See <a href="#">“Adding a RAID-5 Log”</a> on page 148.
<code>vxassist growto <i>volume length</i></code>	Grow a volume to a specified size. See <a href="#">“Resizing Volumes using vxassist”</a> on page 151.
<code>vxassist growby <i>volume length</i></code>	Grow a volume by a specified size. See <a href="#">“Resizing Volumes using vxassist”</a> on page 151.
<code>vxassist shrinkto <i>volume length</i></code>	Shrink a volume to a specified size. See <a href="#">“Resizing Volumes using vxassist”</a> on page 151.
<code>vxassist shrinkby <i>volume length</i></code>	Shrink a volume by a specified size. See <a href="#">“Resizing Volumes using vxassist”</a> on page 151.
<code>vxresize -b -F xvfs <i>volume length</i> \ <i>diskname</i> ...</code>	Resize a volume and the underlying VERITAS File System. See <a href="#">“Resizing Volumes using vxresize”</a> on page 150.
<code>vxvol set exclusive=on <i>volume</i></code>	Configure exclusive access to a volume by a node. See <a href="#">“Setting Exclusive Open Access to a Volume by a Node”</a> on page 211.



---

## Administering Volumes

---

Command	Description
<code>vxassist snapstart <i>volume</i></code>	Prepare a snapshot mirror of a volume. See <a href="#">“Backing Up Volumes Online Using Snapshots”</a> on page 159.
<code>vxassist snapshot <i>volume snapshot</i></code>	Take a snapshot of a volume. See <a href="#">“Backing Up Volumes Online Using Snapshots”</a> on page 159.
<code>vxassist snapback <i>volume snapshot</i></code>	Merge a snapshot with its original volume. See <a href="#">“Merging a Snapshot Volume (snapback)”</a> on page 161.
<code>vxassist snapclear <i>snapshot</i></code>	Make the snapshot volume independent. See <a href="#">“Dissociating a Snapshot Volume”</a> on page 162.
<code>vxassist [-g <i>diskgroup</i>] relayout <i>volume</i> \ [<i>layout=layout</i>] [<i>relayout_options</i>]</code>	Perform online relayout of a volume. See <a href="#">“Performing Online Relayout”</a> on page 163.
<code>vxassist relayout <i>volume</i> layout=raid5 \ stripeunit=<i>W</i> ncol=<i>N</i></code>	Relayout a volume as a RAID-5 volume with stripe width <i>W</i> and <i>N</i> columns. See <a href="#">“Performing Online Relayout”</a> on page 163.
<code>vxrelayout -o bg reverse <i>volume</i></code>	Reverse the direction of a paused volume relayout. See <a href="#">“Controlling the Progress of a Relayout”</a> on page 165.
<code>vxassist convert <i>volume</i> [<i>layout=layout</i>] [<i>convert_options</i>]</code>	Convert between a layered volume and a non-layered volume layout. See <a href="#">“Converting Between Layered and Non-Layered Volumes”</a> on page 166.
<code>vxassist convert <i>volume</i> \ layout=mirror-stripe</code>	Convert a striped-mirror volume to a mirrored-stripe volume. See <a href="#">“Converting Between Layered and Non-Layered Volumes”</a> on page 166.
<code>vxvol stop <i>volume</i></code>	Stop a volume. See <a href="#">“Stopping a Volume”</a> on page 143.
<code>vxassist remove volume <i>volume</i></code>	Remove a volume. See <a href="#">“Removing a Volume”</a> on page 154.

---



---

## Monitoring and Controlling Tasks

---

Command	Description
<code>vxcommand -t <i>tasktag</i> [<i>options</i>] [<i>arguments</i>]</code>	Specify a task tag to a command. See “ <a href="#">Specifying Task Tags</a> ” on page 140.
<code>vxtask [-h] list</code>	List tasks running on a system. See “ <a href="#">vxtask Usage</a> ” on page 142.
<code>vxtask monitor <i>task</i></code>	Monitor the progress of a task. See “ <a href="#">vxtask Usage</a> ” on page 142.
<code>vxtask pause <i>task</i></code>	Suspend operation of a task. See “ <a href="#">vxtask Usage</a> ” on page 142.
<code>vxtask -p list</code>	List all paused tasks. See “ <a href="#">Moving Disk Groups Between Systems</a> ” on page 92.
<code>vxtask resume <i>task</i></code>	Resume a paused task. See “ <a href="#">vxtask Usage</a> ” on page 142.
<code>vxtask abort <i>task</i></code>	Cancel a task and attempt to reverse its effects. See “ <a href="#">vxtask Usage</a> ” on page 142.

---







# Glossary

---

## **active/active disk arrays**

This type of multipathed disk array allows you to access a disk in the disk array through all the paths to the disk simultaneously, without any performance degradation.

## **active/passive disk arrays**

This type of multipathed disk array allows one path to a disk to be designated as primary and used to access the disk at any time. Using a path other than the designated active path results in severe performance degradation in some disk arrays. See “path,” “primary path,” and “secondary path.”

## **associate**

The process of establishing a relationship between VxVM objects; for example, a subdisk that has been created and defined as having a starting point within a plex is referred to as being associated with that plex.

## **associated plex**

A plex associated with a volume.

## **associated subdisk**

A subdisk associated with a plex.

## **atomic operation**

An operation that either succeeds completely or fails and leaves everything as it was before the operation was started. If the operation succeeds, all aspects of the operation take effect at once and the intermediate states of change are invisible. If any aspect of the operation fails, then the operation aborts without leaving partial changes.

## **attached**

A state in which a VxVM object is both associated with another object and enabled for use.



---

**block**

The minimum unit of data transfer to a disk or array.

**boot disk**

A disk used for booting purposes.

**clean node shutdown**

The ability of a node to leave a cluster gracefully when all access to shared volumes has ceased.

**cluster**

A set of hosts that share a set of disks.

**cluster manager**

An externally-provided daemon that runs on each node in a cluster. The cluster managers on each node communicate with each other and inform VxVM of changes in cluster membership.

**cluster-shareable disk group**

A disk group in which the disks are shared by multiple hosts (also referred to as a *shared disk group*).

**column**

A set of one or more subdisks within a striped plex. Striping is achieved by allocating data alternately and evenly across the columns within a plex.

**concatenation**

A layout style characterized by subdisks that are arranged sequentially and contiguously.

**configuration database**

A set of records containing detailed information on existing VxVM objects (such as disk and volume attributes). A single copy of a configuration database is called a configuration copy.

**data stripe**

This represents the usable data portion of a stripe and is equal to the stripe minus the parity region.



---

## detached

A state in which a VxVM object is associated with another object, but not enabled for use.

## device name

The device name or address used to access a physical disk, such as `c0t0d0`. The `c#t#d#` syntax identifies the controller, target address, and disk.

## dirty region logging

The procedure by which the VxVM monitors and logs modifications to a plex. A bitmap of changed regions is kept in an associated subdisk called a *log subdisk*.

## disabled path

A path to a disk that is not available for I/O. A path can be *disabled* due to real hardware failures or if the user has used the `vxdmpadm disable` command on that controller.

## disk

A collection of read/write data blocks that are indexed and can be accessed fairly quickly. Each disk has a universally unique identifier.

## disk access name

The name used to access a physical disk, such as `s2`. The `s#` syntax identifies the controller, target address, disk, and partition. The term *device name* can also be used to refer to the disk access name.

## disk access records

Configuration records used to specify the access path to particular disks. Each disk access record contains a name, a type, and possibly some type-specific information, which is used by VxVM in deciding how to access and manipulate the disk that is defined by the disk access record.

## disk array

A collection of disks logically arranged into an object. Arrays tend to provide benefits such as redundancy or improved performance.

## disk array serial number

This is the serial number of the disk array. It is usually printed on the disk array cabinet or can be obtained by issuing a vendor-specific SCSI command to the disks on the disk array. This number is used by the DMP subsystem to uniquely identify a disk array.



---

## disk controller

In the multipathing subsystem of VxVM, the controller (host bus adapter or HBA) or disk array connected to the host, which the Operating System represents as the parent node of a disk. For example, if a disk is represented by the device name `/dev/sbus@1f,0/QLGC,isp@2,10000/sd@8,0:c` then the path component `QLGC,isp@2,10000` represents the disk controller that is connected to the host for disk `sd@8,0:c`.

## disk group

A collection of disks that share a common configuration. A disk group configuration is a set of records containing detailed information on existing VxVM objects (such as disk and volume attributes) and their relationships. Each disk group has an administrator-assigned name and an internally defined unique ID. The root disk group (`rootdgroup`) is a special private disk group that always exists.

## disk group ID

A unique identifier used to identify a disk group.

## disk ID

A universally unique identifier that is given to each disk and can be used to identify the disk, even if it is moved.

## disk media name

A logical or administrative name chosen for the disk, such as `disk03`. The term *disk name* is also used to refer to the disk media name.

## disk media record

A configuration record that identifies a particular disk, by disk ID, and gives that disk a logical (or administrative) name.

## dissociate

The process by which any link that exists between two VxVM objects is removed. For example, dissociating a subdisk from a plex removes the subdisk from the plex and adds the subdisk to the free space pool.

## dissociated plex

A plex dissociated from a volume.

## dissociated subdisk

A subdisk dissociated from a plex.



---

### distributed lock manager

A lock manager that runs on different systems in a cluster, and ensures consistent access to distributed resources.

### enabled path

A path to a disk that is available for I/O.

### encapsulation

A process that converts existing partitions on a specified disk to volumes. If any partitions contain file systems, `/etc/vfstab` entries are modified so that the file systems are mounted on volumes instead. Encapsulation is not applicable on some operating systems.

### file system

A collection of files organized together into a structure. The UNIX file system is a hierarchical structure consisting of directories and files.

### free space

An area of a disk under VxVM control that is not allocated to any subdisk or reserved for use by any other VxVM object.

### free subdisk

A subdisk that is not associated with any plex and has an empty `putil[0]` field.

### hostid

A string that identifies a host to VxVM. The *hostid* for a host is stored in its `volboot` file, and is used in defining ownership of disks and disk groups.

### hot-relocation

A technique of automatically restoring redundancy and access to mirrored and RAID-5 volumes when a disk fails. This is done by relocating the affected subdisks to disks designated as spares and/or free space in the same disk group.

### initiating node

The node on which the system administrator is running a utility that requests a change to VxVM objects. This node initiates a volume reconfiguration.

### log plex

A plex used to store a RAID-5 log. The term *log plex* may also be used to refer to a Dirty Region Logging plex.



---

## log subdisk

A subdisk that is used to store a dirty region log.

## master node

A node that is designated by the software to coordinate certain VxVM operations in a cluster. Any node is capable of being the master node.

## mastering node

The node to which a disk is attached. This is also known as a *disk owner*.

## mirror

A duplicate copy of a volume and the data therein (in the form of an ordered collection of subdisks). Each mirror consists of one *plex* of the volume with which the mirror is associated.

## mirroring

A layout technique that mirrors the contents of a volume onto multiple plexes. Each plex duplicates the data stored on the volume, but the plexes themselves may have different layouts.

## multipathing

Where there are multiple physical access paths to a disk connected to a system, the disk is called multipathed. Any software residing on the host, (for example, the DMP driver) that hides this fact from the user is said to provide multipathing functionality.

## node

One of the hosts in a cluster.

## node abort

A situation where a node leaves a cluster (on an emergency basis) without attempting to stop ongoing operations.

## node join

The process through which a node joins a cluster and gains access to shared disks.

## object

An entity that is defined to and recognized internally by VxVM. The VxVM objects are: volume, plex, subdisk, disk, and disk group. There are actually two types of disk objects—one for the physical aspect of the disk and the other for the logical aspect.



---

## parity

A calculated value that can be used to reconstruct data after a failure. While data is being written to a RAID-5 volume, parity is also calculated by performing an *exclusive OR* (XOR) procedure on data. The resulting parity is then written to the volume. If a portion of a RAID-5 volume fails, the data that was on that portion of the failed volume can be recreated from the remaining data and the parity.

## parity stripe unit

A RAID-5 volume storage region that contains parity information. The data contained in the parity stripe unit can be used to help reconstruct regions of a RAID-5 volume that are missing because of I/O or disk failures.

## partition

The standard division of a physical disk device, as supported directly by the operating system and disk drives.

## path

When a disk is connected to a host, the path to the disk consists of the HBA (Host Bus Adapter) on the host, the SCSI or fibre cable connector and the controller on the disk or disk array. These components constitute a path to a disk. A failure on any of these results in DMP trying to shift all I/O for that disk onto the remaining (alternate) paths.

## pathgroup

In case of disks which are not multipathed by `vxdmp`, VxVM will see each path as a disk. In such cases, all paths to the disk can be grouped. This way only one of the paths from the group is made visible to VxVM.

## persistent state logging

A logging type that ensures that only active mirrors are used for recovery purposes and prevents failed mirrors from being selected for recovery. This is also known as *kernel logging*.

## physical disk

The underlying storage device, which may or may not be under VxVM control.

## plex

A plex is a logical grouping of subdisks that creates an area of disk space independent of physical disk size or other restrictions. Mirroring is set up by creating multiple data plexes for a single volume. Each data plex in a mirrored volume contains an identical copy of the volume data. Plexes may also be created to represent concatenated, striped and RAID-5 volume layouts, and to store volume logs.



---

## primary path

In Active/Passive type disk arrays, a disk can be bound to one particular controller on the disk array or owned by a controller. The disk can then be accessed using the path through this particular controller. See “path” and “secondary path.”

## private disk group

A disk group in which the disks are accessed by only one specific host in a cluster.

## private region

A region of a physical disk used to store private, structured VxVM information. The *private region* contains a disk header, a table of contents, and a configuration database. The table of contents maps the contents of the disk. The disk header contains a disk ID. All data in the private region is duplicated for extra reliability.

## public region

A region of a physical disk managed by VxVM that contains available space and is used for allocating subdisks.

## RAID

A Redundant Array of Independent Disks (RAID) is a disk array set up with part of the combined storage capacity used for storing duplicate information about the data stored in that array. This makes it possible to regenerate the data if a disk failure occurs.

## read-writeback mode

A recovery mode in which each read operation recovers plex consistency for the region covered by the read. Plex consistency is recovered by reading data from blocks of one plex and writing the data to all other writable plexes.

## root configuration

The configuration database for the root disk group. This is special in that it always contains records for other disk groups, which are used for backup purposes only. It also contains disk records that define all disk devices on the system.

## root disk

The disk containing the root file system. This disk may be under VxVM control.

## root disk group

A special private disk group that always exists on the system. The root disk group is named `rootdg`.





---

### root file system

The initial file system mounted as part of the UNIX kernel startup sequence.

### root partition

The disk region on which the root file system resides.

### root volume

The VxVM volume that contains the root file system, if such a volume is designated by the system configuration.

### rootability

The ability to place the `root` file system and the `swap` device under VxVM control. The resulting volumes can then be mirrored to provide redundancy and allow recovery in the event of disk failure.

### secondary path

In Active/Passive type disk arrays, the paths to a disk other than the primary path are called secondary paths. A disk is supposed to be accessed only through the primary path until it fails, after which ownership of the disk is transferred to one of the secondary paths. See “path” and “primary path.”

### sector

A unit of size, which can vary between systems. A sector is commonly 512 bytes.

### shared disk group

A disk group in which the disks are shared by multiple hosts (also referred to as a *cluster-shareable disk group*).

### shared volume

A volume that belongs to a shared disk group and is open on more than one node of a cluster at the same time.

### shared VM disk

A VM disk that belongs to a shared disk group in a cluster.

### slave node

A node that is not designated as the master node of a cluster.



---

## slice

The standard division of a logical disk device. The terms *partition* and *slice* are sometimes used synonymously.

## spanning

A layout technique that permits a volume (and its file system or database) that is too large to fit on a single disk to be configured across multiple physical disks.

## sparse plex

A plex that is not as long as the volume or that has holes (regions of the plex that do not have a backing subdisk).

## stripe

A set of stripe units that occupy the same positions across a series of columns.

## stripe size

The sum of the stripe unit sizes comprising a single stripe across all columns being striped.

## stripe unit

Equally-sized areas that are allocated alternately on the subdisks (within columns) of each striped plex. In an array, this is a set of logically contiguous blocks that exist on each disk before allocations are made from the next disk in the array. A *stripe unit* may also be referred to as a *stripe element*.

## stripe unit size

The size of each stripe unit. The default stripe unit size is 32 sectors (16K). A *stripe unit size* has also historically been referred to as a *stripe width*.

## striping

A layout technique that spreads data across several physical disks using stripes. The data is allocated alternately to the stripes within the subdisks of each plex.

## subdisk

A consecutive set of contiguous disk blocks that form a logical disk segment. Subdisks can be associated with plexes to form volumes.

## swap area

A disk region used to hold copies of memory pages swapped out by the system pager process.



---

## swap volume

A VxVM volume that is configured for use as a swap area.

## transaction

A set of configuration changes that succeed or fail as a group, rather than individually. Transactions are used internally to maintain consistent configurations.

## volboot file

A small file that is used to locate copies of the root configuration. The file may list disks that contain configuration copies in standard locations, and can also contain direct pointers to configuration copy locations. The `volboot` file is stored in a system-dependent location.

## VM disk

A disk that is both under VxVM control and assigned to a disk group. VM disks are sometimes referred to as VxVM disks or simply disks.

## volume

A virtual disk, representing an addressable range of disk blocks used by applications such as file systems or databases. A volume is a collection of from one to 32 plexes.

## volume configuration device

The volume configuration device (`/dev/vx/config`) is the interface through which all configuration changes to the volume device driver are performed.

## volume device driver

The driver that forms the virtual disk drive between the application and the physical device driver level. The volume device driver is accessed through a virtual disk device node whose character device nodes appear in `/dev/vx/rdisk`, and whose block device nodes appear in `/dev/vx/dsk`.

## volume event log

The device interface (`/dev/vx/event`) through which volume driver events are reported to utilities.

## vxconfigd

The VxVM configuration daemon, which is responsible for making changes to the VxVM configuration. This daemon must be running before VxVM operations can be performed.





# Index

---

## Symbols

- /dev/vx/dsk block device files 136
- /dev/vx/rdisk character device files 136
- /etc/default/vxassist defaults file 125
- /etc/default/vxdg defaults file 201
- /etc/rc2.d/S95vxvm-recover file 181
- /etc/system file 228
- /etc/vfstab file 154
- /etc/vx/cntrl.exclude file 45
- /etc/vx/disks.exclude file 45
- /stand/system file 228

## A

- activation modes
  - exclusive-write 194
  - for shared disk groups in clusters 194
  - off 194
  - read-only 194
  - shared-read 194
  - shared-write 194
- ACTIVE
  - plex state 111
  - volume state 138
- adding disks 51
- Allow Multipathing/Unsuppress Devices from VxVM's View 77
- attributes
  - changing for plexes 119
  - changing for subdisks 107
  - plex comment 119
  - plex name 119
  - plex putil 119
  - plex tutil 119
  - subdisk comment 107
  - subdisk len 107
  - subdisk name 107
  - subdisk putil 107
  - subdisk tutil 107

## B

- backups
  - created using snapshots 159
  - creating for volumes 157
  - creating from a mirror 157
  - creating using snapshots 159
  - for multiple volumes 161
  - of RAID-5 volumes 159
- blocks
  - on disks 7
- boot
  - restrictions 52
- boot disk
  - defining aliases for 58
  - defining alternate 57
  - encapsulating 56
  - listing volumes on 57
  - mirroring 56
  - using aliases 57
- booting
  - root volume 52

## C

- c# 3, 43
- c0d0t0 43
- checkpoints
  - interval 230
- CLEAN
  - plex state 111
  - volume state 138
- cluster manager
  - operation of 195
- cluster protocol version
  - checking 216
  - upgrading 216
- cluster protocol version number 205
- clusters
  - activating disk groups 201
  - activating shared disk groups 209



- activation modes for shared disk groups 194
- checking cluster protocol version 216
- cluster manager 195
- cluster protocol version number 205
- cluster-shareable disk groups 194
- configuration 197
- configuring exclusive open of volume by node 211
- converting shared disk groups to private 209
- creating shared disk groups 208
- designating shareable disk groups 196
- determining if disks are shared 208
- dirty region log 203
- forcibly adding disks to disk groups 210
- forcibly importing disk groups 210
- global connectivity policy 201
- importing disk groups as shared 209
- initialization 197
- limitations of shared disk groups 195
- listing shared disk groups 210
- local connectivity policy 201
- maximum number of nodes 193
- node abort 200
- node shutdown 199
- nodes 195
- operation of DRL in 202, 204
- operation of FastResync in 206
- operation of vxconfigd in 213
- operation of VxVM in 193, 195
- private disk groups 194
- protection against simultaneous writes 197
- reconfiguration of 198
- resolving disk status in 201
- setting disk connectivity policies in 209
- shared disk groups 194
- shared objects 194
- shutdown 200
- upgrading cluster protocol version 216
- upgrading online 205
- vol\_fmr\_logsz tunable 206
- volume reconfiguration 198
- vxclust 212
- vxclustadm 213
- vxctl 215
- vxrecover 216
- vxstat 217
- cluster-shareable disk groups
  - in clusters 194
- columns
  - changing number of 163
  - in striping 15
  - mirroring in striped-mirror volumes 131
- comment
  - plex attribute 119
  - subdisk attribute 107
- concatenated volumes 13, 121
- concatenated-mirror volumes 21, 122
  - converting to mirrored-concatenated 166
  - creating 129
- Concatenated-Pro volumes 122
- concatenation 13
- condition flags
  - for plexes 113
- configuration copies
  - setting number for disk group 229
- configuration database
  - obtaining copy size of 83
- connectivity policies
  - global 201
  - local 201
  - setting for disk groups 209
- controllers
  - disabling for DMP 189, 190
  - disabling in DMP 186
  - enabling in DMP 186
  - mirroring across 132
  - number 3
  - specifying to vxassist 128

**D**

- d# 3, 43
- data
  - redundancy 18, 19, 20, 22
- data volume
  - configuration 42
- database replay logs
  - and sequential DRL 36
- databases
  - redo logs 41
  - resilvering 41
  - resynchronization 41
- description file
  - used with vxmake 135
- DETACHED



- plex kernel state 114
- volume kernel state 140
- devalias
  - used to list alternate boot disks 57
- device files
  - to access volumes 136
- device names 3, 43
- devices
  - metadevices 44
  - nopriv 58
  - pathname 43
  - special 44
  - standard 44
  - suppress devices 71
  - unsuppress devices 77
  - volatile 59
- dirty bits
  - in DRL 36
- dirty flags
  - set on volumes 35
- dirty region logging. See DRL
- dirty regions
  - maximum number for sequential DRL 234
  - maximum number of 233
- DISABLED
  - plex kernel state 114
  - volume kernel state 140
- disabled paths
  - displaying 70
- disk arrays
  - use of 4
- disk groups
  - activating shared 209
  - activation in clusters 201
  - adding disks to 85
  - avoiding conflicting minor numbers on import 94
  - clearing locks on disks 92
  - cluster-shareable 194
  - converting to private 209
  - creating 84
  - creating shared 208
  - creating with old version number 99
  - default 83
  - defaults file for shared 201
  - defined 7
  - deporting 87
  - designating as shareable 196
  - destroying 95
  - disabling 94
  - displaying free space in 96
  - displaying information about 95
  - displaying version of 99
  - effect of size on private region 83
  - features supported by version 98
  - forcing import of 93
  - free space in 171
  - global connectivity policy for shared 201
  - impact of number of configuration copies on performance 229
  - importing 88
  - importing as shared 209
  - importing forcibly 210
  - listing shared 210
  - local connectivity policy for shared 201
  - moving between systems 92
  - moving disks between 91
  - private in clusters 194
  - removing disks from 86
  - renaming 90
  - reserving minor numbers 94
  - root 7
  - rootdg 7, 83
  - setting connectivity policies in clusters 209
  - setting number of configuration copies 229
  - shared in clusters 194
  - specifying to commands 84
  - upgrading version of 97, 99
  - version 97
    - assignments 98
    - features supported by 98
- disk media names 6, 43
- disk names 43
- disk## 7, 43
- disk###-## 7
- disks 168
  - adding 51
  - adding to disk groups 85
  - adding to disk groups forcibly 210
  - c0t0d0 43
  - clearing locks on 92
  - complete failure messages 170
  - determining failed 170
  - determining if shared 208
  - disabled path 70



---

- disk arrays 4
- displaying information 69, 71
- displaying information about 96
- displaying spare 173
- enabled path 70
- enabling 66
- enabling after hot swap 67
- encapsulating 45
- encapsulation 51, 53
- excluding free space from hot-relocation use 175
- formatting 46
- hot-relocation 167
- in cluster environments 193
- initializing 44, 46
- installing 46
- making available for hot-relocation 173
- making free space available for hot-relocation use 175
- marking as spare 173
- media name 43
- metadevices 44
- mirroring boot disk 56
- mirroring root disk 56
- mirroring volumes on 145
- moving between disk groups 91
- moving disk groups between systems 92
- moving volumes from 155
- names 43
- nopriv 44
- nopriv devices 58
- number 3
- obtaining performance statistics 226
- partial failure messages 169
- postponing replacement 63
- primary path 70
- putting under control of VxVM 44
- reinitializing 50
- releasing from disk groups 95
- removing 60, 63
- removing from disk groups 86
- removing from pool of hot-relocation spares 174
- removing with subdisks 61, 62
- renaming 68
- replacing 63
- replacing removed 65
- reserving for special purposes 68
- resolving status in clusters 201

- root disk 51
- secondary path 70
- setting connectivity policies in clusters 209
- simple 44
- sliced 44
- spare 171
- special devices 44
- specifying to vxassist 128
- standard devices 44
- taking offline 67
- unreserving 69
- VM disks 6

DMP

- allow multipathing 77
- booting from DMP devices 186
- check\_all restore policy 190
- check\_disabled restore policy 190
- disabling controllers 189, 190
- displaying DMP database information 186
- displaying DMP node for a path 187
- displaying DMP node for an enclosure 187
- displaying information about paths 69
- displaying paths controlled by DMP node 188
- displaying status of DMP error daemons 191
- displaying status of DMP restore daemon 191
- dynamic multipathing 183
- listing controllers 188
- listing enclosures 189
- load balancing 185
- path failover mechanism 185
- prevent multipathing 71
- renaming an enclosure 190
- restore policy 190
- setting the DMP restore polling interval 190
- starting the DMP restore daemon 190
- stopping the DMP restore daemon 191
- vxdmpadm 187

DRL

- adding log subdisks 105
- adding logs to mirrored volumes 147
- creating mirrored volumes with logging enabled 130



- creating mirrored volumes with sequential DRL enabled 130
  - dirty region logging 35
  - handling recovery in clusters 204
  - hot-relocation limitations 169
  - log subdisks 36
  - maximum number of dirty regions 233
  - minimum number of sectors 234
  - operation in clusters 202
  - removing logs from mirrored volumes 147
  - sequential 36
- DRL logs
  - handling additional nodes in clusters 203
  - in clusters 203
- E**
- eeprom
  - used to allow boot disk aliases 57
  - used to define alternate boot disks 58
- EEPROM variables
  - nvramrc 58
  - use-nvramrc 57
- EMPTY
  - plex state 111
  - volume state 139
- ENABLED
  - plex kernel state 114
  - volume kernel state 140
- enabled paths
  - displaying 70
- encapsulating disks 51, 53
- encapsulation
  - failure of 56
  - of disks 45
- error messages
  - Disk for disk group not found 93
  - Disk group has no valid configuration copies 93
  - Disk group version doesn't support feature 97
  - Disk is in use by another host 92
  - Disk is used by one or more subdisks 62, 86
  - import failed 92
  - It is not possible to encapsulate 56
  - The encapsulation operation failed 56
  - unsupported layout 56
- Exclude controllers 72
- Exclude devices 72
- Exclude devices from being multipathed 75
- Exclude disks 73
- Exclude disks from being multipathed 76
- Exclude paths 73
- Exclude paths from being multipathed 75
- exclusive open
  - configuring on volumes in clusters 211
- exclusive write
  - activation mode for shared disk groups 194
- F**
- failure handled by hot-relocation 168
- failure in RAID-5 handled by hot-relocation 168
- fast mirror resynchronization. See FastResync
- FastResync
  - disabling on mirrored volumes 157
  - enabling on mirrored volumes 156
  - FR 37
  - operation in clusters 206
  - persistence in memory 40
  - size of bitmap 230
  - snapshot enhancements 38
  - use by snapshots 39
- file systems
  - growing using vxresize 150
  - mirroring on root disk 57
  - permitted resizing operations 150
  - shrinking using vxresize 150
  - unmounting 154
- formatting
  - disks 46
- FR. See FastResync
- free space
  - in disk groups 171
  - used for hot-relocation 171
- G**
- groupname## 43
- H**
- hot-relocation 42
  - complete failure messages 170
  - configuration summary 172
  - daemon 168
  - detecting disk failure 168



- detecting plex failure 168
- detecting RAID-5 subdisk failure 168
- excluding free space on disks from use by 175
- limitations 169
- making free space on disks available for use by 175
- marking disks as spare 173
- modifying behavior of 181
- notifying users other than root 182
- operation of 167
- partial failure messages 169
- reducing performance impact of recovery 182
- removing disks from spare pool 174
- subdisk relocation 172
- subdisk relocation messages 176
- unrelocating subdisks 176
- unrelocating subdisks using vxassist 178
- unrelocating subdisks using vxdiskadm 177
- unrelocating subdisks using vxunreloc 179
- use of free space in disk groups 171
- use of spare disks 171
- use of spare disks and free space 171
- vxrelocd 168

## I

- I/O
  - use of statistics in performance tuning 225
  - using traces for performance tuning 228
- I/O operations
  - maximum number in parallel 232
  - maximum size of 231
- identifiers
  - for tasks 140
- initialization
  - of disks 44, 46
- ioctl calls
  - maximum size of data passed by 232
  - maximum size of I/O request by 232
- IOFAIL
  - plex state 112

## K

- kernel states
  - for plexes 114
  - volumes 140

## L

- layered volumes 20, 27, 122
  - converting to non-layered 166
- layouts
  - changing default used by vxassist 127
  - left-symmetric 24
  - specifying default 127
  - types of volume 121
- left-symmetric layout 24
- len
  - subdisk attribute 107
- locks
  - clearing on disks 92
- LOG
  - plex state 112
- log subdisks
  - associating with plexes 105
  - DRL 36
- logging
  - RAID-5 26, 35
- logs
  - adding DRL log 147
  - adding for RAID-5 148
  - adding sequential DRL logs 147
  - RAID-5 26, 35
  - removing DRL log 147
  - removing for RAID-5 148
  - removing sequential DRL logs 147
  - resizing using vxvol 152
  - specifying number for RAID-5 133

## M

- memory
  - granularity of allocation by VxVM 234
  - maximum size of pool for VxVM 234
  - persistence of FastResync in 40
- messages
  - complete disk failure 170
  - hot-relocation of subdisks 176
  - partial disk failure 169
- metadevices 44
- minor numbers
  - avoiding conflicts for imported disk groups 94
  - reserving for disk groups 94
- mirrored volumes 18, 122
  - adding DRL logs 147
  - adding sequential DRL logs 147
  - changing read-policies for 153



- configuring VxVM to create by default 145
- creating 129
- creating across controllers 132
- creating across targets 132
- creating with logging enabled 130
- creating with sequential DRL enabled 130
- dirty region logging 35
- disabling FastResync 157
- DRL 35
- enabling FastResync 156
- FastResync 35
- FR 35
- logging 35
- performance 220
- removing DRL logs 147
- removing sequential DRL logs 147
- snapshots 37
- mirrored-concatenated volumes 19
  - converting to concatenated-mirror 166
  - creating 129
- mirrored-stripe volumes 19, 122
  - converting to striped-mirror 166
  - creating 131
  - performance 221
- mirroring 18
  - boot disk 56
  - root disk 56
- mirroring plus striping 20
- mirrors 10
  - adding to volumes 144
  - creating snapshot 160
  - removing from volumes 146
  - specifying number of 129
- multipathing
  - allow multipathing 77
  - displaying information about 69
  - prevent multipathing 71

## N

- name
  - plex attribute 119
  - subdisk attribute 107
- names
  - changing for disk groups 90
  - defining for snapshot volumes 161
  - device 3, 43
  - disk 43

- disk media 6, 43
  - plex 9
  - renaming disks 68
  - subdisk 7
  - VM disk 7
  - volume 9
- NEEDSYNC
  - volume state 139
- nodes
  - in clusters 195
  - node abort in clusters 200
  - shutdown in clusters 199
  - use of vxclust 212
  - use of vxclustadm to control cluster functionality 213
- NODEVICE
  - plex condition 113
- non-layered volumes
  - converting to layered 166
- nopriv devices 58
  - limitations 59
- nopriv disk type 44
- nvramrc variable
  - EEPROM variable 58

## O

- objects
  - physical 3
  - virtual 6
- off
  - activation mode for shared disk groups 194
- OFFLINE
  - plex state 112
- online relayout 28
  - changing number of columns 163
  - changing region size 165
  - changing speed of 165
  - changing stripe unit size 163
  - combining with conversion 166
  - controlling progress of 165
  - destination layouts 163
  - failure recovery 34
  - how it works 29
  - limitations 30
  - monitoring tasks for 165
  - pausing 165
  - performing 163
  - resuming 165



---

- reversing direction of 165
- specifying non-default 163
- specifying plexes 164
- specifying task tags for 164
- temporary area 29
- transformation characteristics 33
- transformations and volume length 34
- types of transformation 30
- viewing status of 164

## P

- parity
  - in RAID-5 22
- partitions
  - number 4
  - s2 43
  - s3 44
  - s4 44
  - slices 4
- path failover
  - DMP 185
- pathgroup
  - create 74
  - remove 79
- performance
  - analyzing data 225
  - benefits of using VxVM 219
  - changing values of tunables 229
  - combining mirroring and striping 221
  - effect of read policies 221
  - examining ratio of reads to writes 227
  - hot spots identified by I/O traces 228
  - impact of number of disk group configuration copies 229
  - load balancing in DMP 185
  - mirrored volumes 220
  - monitoring 223
  - moving volumes to improve 226
  - obtaining statistics for disks 226
  - obtaining statistics for volumes 224
  - RAID-5 volumes 221
  - setting priorities 223
  - striped volumes 220
  - striping to improve 227
  - tracing volume operations 223
  - tuning large systems 228
  - tuning VxVM 228
  - using I/O statistics 225
- physical disks
  - adding to disk groups 85
  - clearing locks on 92
  - complete failure messages 170
  - determining failed 170
  - displaying information 69
  - displaying information about 96
  - displaying spare 173
  - enabling 66
  - enabling after hot swap 67
  - excluding free space from hot-relocation use 175
  - failure handled by hot-relocation 168
  - initializing 44
  - installing 46
  - making available for hot-relocation 173
  - making free space available for hot-relocation use 175
  - marking as spare 173
  - moving between disk groups 91
  - moving disk groups between systems 92
  - moving volumes from 155
  - partial failure messages 169
  - postponing replacement 63
  - releasing from disk groups 95
  - removing 60, 63
  - removing from disk groups 86
  - removing from pool of hot-relocation spares 174
  - removing with subdisks 61, 62
  - replacing 63
  - replacing removed 65
  - reserving for special purposes 68
  - spare 171
  - taking offline 67
  - unreserving 69
- physical objects 3
- plex conditions
  - NODEVICE 113
  - RECOVER 114
  - REMOVED 114
- plex kernel states
  - DETACHED 114
  - DISABLED 114
  - ENABLED 114
- plex states
  - ACTIVE 111
  - CLEAN 111
  - EMPTY 111
  - IOFAIL 112



- LOG 112
- OFFLINE 112
- SNAPDONE 112
- SNAPTMP 112
- STALE 112
- TEMP 113
- TEMPRM 113
- TEMPRMSD 113
- plexes 168
  - associating log subdisks with 105
  - associating subdisks with 104
  - associating with volumes 115
  - attaching to volumes 115
  - changing attributes 119
  - changing read-policies for 153
  - comment attribute 119
  - complete failure messages 170
  - condition flags 113
  - copying 118
  - creating 109
  - creating striped 110
  - defined 8
  - detaching from volumes temporarily 116
  - disconnecting from volumes 115
  - displaying information about 110
  - dissociating from volumes 118
  - dissociating subdisks from 106
  - kernel states 114
  - limit on number per volume 222
  - maximum number of subdisks 233
  - maximum number per volume 9
  - mirrors 10
  - moving 117
  - name attribute 119
  - names 9
  - partial failure messages 169
  - putil attribute 119
  - putting online 116, 143
  - reattaching 116
  - recovering after correctable hardware failure 170
  - removing 118
  - sparse 104
  - specifying for online relay layout 164
  - states 110
  - striped 15
  - taking offline 115, 143
  - tutil attribute 119
  - types 8

- polling interval
  - setting for DMP restore 190
- preferred plex
  - performance of read policy 222
  - read policy 153
- Prevent Multipathing/Suppress Devices from VxVM's view 71
- primary path
  - displaying 70
- private disk groups
  - converting from shared 209
  - in clusters 194
- private region 44
  - effect of large disk groups on 83
- public region 44
- putil 119
  - plex attribute 119
  - subdisk attribute 107

**R**

- RAID-0 15
- RAID-0+1 19
- RAID-1 18
- RAID-1+0 20
- RAID-5
  - adding logs 148
  - adding subdisks to plexes 105
  - hot-relocation limitations 169
  - logs 26, 35
  - parity 22
  - removing logs 148
  - specifying number of logs 133
  - subdisk failure handled by hot-relocation 168
  - volumes 22
- RAID-5 volumes 122
  - adding logs 148
  - changing number of columns 163
  - changing stripe unit size 163
  - creating 132
  - making backups of 159
  - performance 221
  - removing logs 148
  - taking snapshots of 159
- read policies
  - changing 153
  - performance of 221
  - prefer 153
  - select 153



- read-only
    - activation mode for shared disk groups 194
  - read-policies
    - round 153
  - RECOVER
    - plex condition 114
  - recovery
    - checkpoint interval 230
    - I/O delay 230
    - preventing on restarting volumes 144
  - recovery accelerator 41
  - redo log
    - configuration 42
  - redundancy
    - of data on mirrors 122
  - region
    - private 44
    - public 44
  - Re-include controllers for multipathing 80
  - Re-include controllers in VxVM 78
  - Re-include devices in VxVM 77
  - Re-include disks for multipathing 81
  - Re-include disks in VxVM 78
  - Re-include paths for multipathing 80
  - Re-include paths in VxVM 78
  - reinitialization
    - of disks 50
  - relayout
    - changing number of columns 163
    - changing region size 165
    - changing speed of 165
    - changing stripe unit size 163
    - combining with conversion 166
    - controlling progress of 165
    - limitations 30
    - monitoring tasks for 165
    - online 28
    - pausing 165
    - performing online 163
    - resuming 165
    - reversing direction of 165
    - specifying non-default 163
    - specifying plexes 164
    - specifying task tags for 164
    - storage 28
    - transformation characteristics 33
    - types of transformation 30
    - viewing status of 164
  - relocation
    - automatic 167
    - complete failure messages 170
    - limitations 169
    - partial failure messages 169
  - REMOVED
    - plex condition 114
  - removing disks 63
  - removing physical disks 60
  - replacing disks 63
  - REPLAY
    - volume state 139
  - replay logs
    - and sequential DRL 36
  - resilvering
    - of databases 41
  - restore policy
    - check\_all 190
    - check\_disabled 190
  - resyncfromoriginal
    - snapback 40
  - resyncfromreplica
    - snapback 40
  - resynchronization
    - checkpoint interval 230
    - I/O delay 230
    - of volumes 34
  - root disk 51
    - encapsulating 56
    - listing volumes on 57
    - mirroring 56
    - mirroring other file systems on 57
  - root disk group 7, 83
  - root volume
    - booting 52
    - restrictions 52
  - rootability 51
  - rootdg 7
  - round-robin
    - performance of read policy 222
    - read policy 153
  - round-robin read policy
    - granularity of 233
- S**
- s# 4
  - s2 partition 43
  - s3 partition 44
  - s4 partition 44



---

- secondary path
  - displaying 70
- sequential DRL 36
  - creating mirrored volumes with logging enabled 130
  - maximum number of dirty regions 234
- shared disk group
  - activating 209
- shared disk groups
  - activation modes 194
  - converting to private 209
  - creating 208
  - importing 209
  - in clusters 194
  - limitations of 195
  - listing 210
- shared-read
  - activation mode for shared disk groups 194
- shared-write
  - activation mode for shared disk groups 194
- simple disk type 44
- size units 101
- sliced disk type 44
- slices
  - partitions 4
  - s2 43
  - s3 44
  - s4 44
- snap volumes
  - naming 40
- snapback 38
  - resyncfromoriginal 40
  - resyncfromreplica 40, 162
  - used to merge snapshot volumes 161
- snapclear 38
  - used to create independent volumes 162
- SNAPDONE
  - plex state 112
- snapshot 38
- snapshots 37
  - backing up multiple volumes 161
  - creating backups 159
  - creating independent volumes 162
  - defining names for 161
  - displaying information about 162
  - merging with original volumes 161
  - of RAID-5 volumes 159
  - on multiple volumes 40
  - removing 161
  - resynchronization on snapback 40
  - resynchronizing volumes from 162
  - used to back up volumes online 159
- snapstart 38
- SNAPTMP
  - plex state 112
- spanned volumes 13
- spanning 13
- spare disks
  - displaying 173
  - marking disks as 173
  - used for hot-relocation 171
- sparse plexes
  - filling in 104
- special disk devices 44
- STALE
  - plex state 112
- standard disk devices 44
- states
  - for plexes 110
  - volume 138
- storage attributes
  - defining volume layout using 128
- storage relayout 28
- stripe columns 15
- stripe unit size
  - changing 163
- stripe units 15
- striped plexes 15
  - adding subdisks 105
- striped volumes 15, 121
  - changing number of columns 163
  - changing stripe unit size 163
  - creating 130
  - performance 220
  - specifying non-default number of columns 130
  - specifying non-default stripe unit size 130
- striped-mirror volumes 20, 122
  - converting to mirrored-stripe 166
  - creating 131
  - mirroring columns 131
  - mirroring subdisks 131
  - performance 221
  - trigger point for mirroring 131
- Striped-Pro volumes 122



- stripe-mirror-col-split-trigger-pt 131
- striping 15
  - unit size 15
  - width 15
- striping plus mirroring 19
- subdisk names 7
- subdisks 168
  - associating log subdisks 105
  - associating with plexes 104
  - associating with RAID-5 plexes 105
  - associating with striped plexes 105
  - blocks 7
  - changing attributes 107
  - comment attribute 107
  - complete failure messages 170
  - copying contents of 102
  - creating 101
  - defined 7
  - determining failed 170
  - displaying information about 102
  - dissociating from plexes 106
  - dividing 103
  - DRL log 36
  - hot-relocated 172
  - hot-relocation 42, 167
  - hot-relocation messages 176
  - joining 103
  - len attribute 107
  - listing original disks after hot-relocation 180
  - maximum number per plex 233
  - mirroring in striped-mirror volumes 131
  - moving after hot-relocation 176
  - moving contents of 102
  - name attribute 107
  - partial failure messages 169
  - putil attribute 107
  - removing from VxVM 106
  - restrictions on moving 103
  - specifying different offsets for unrelocation 180
  - splitting 103
  - tutil attribute 107
  - unrelocating after hot-relocation 176
  - unrelocating to different disks 179
  - unrelocating using vxassist 178
  - unrelocating using vxdiskadm 177
  - unrelocating using vxunreloc 179
- swap volume

- restrictions 52
- SYNC
  - volume state 139

## T

- t# 3, 43
- tags
  - for tasks 140
  - specifying for online relay layout tasks 164
  - specifying for tasks 140
- target IDs
  - number 3
  - specifying to vxassist 128
- targets
  - mirroring across 132
- task monitor
  - in VxVM 140
- tasks
  - aborting 142
  - changing state of 142
  - identifiers 140
  - listing 141
  - managing 141
  - modifying parameters of 142
  - monitoring 142
  - monitoring online relay layout 165
  - pausing 142
  - resuming 142
  - specifying tags 140
  - specifying tags on online relay layout operation 164
  - tags 140
- TEMP
  - plex state 113
- temporary area
  - used by online relay layout 29
- TEMPRM
  - plex state 113
- TEMPRMSD
  - plex state 113
- trigger point
  - for mirroring in striped-mirror volumes 131
- tunables
  - changing values of 229
  - vol\_checkpt\_default 230
  - vol\_default\_iodelay 230
  - vol\_fmr\_logsz 39, 206, 230
  - vol\_max\_vol 231





- vol\_maxio 231
  - vol\_maxioctl 232
  - vol\_maxkiocount 232
  - vol\_maxparallelio 232
  - vol\_maxspecialio 232
  - vol\_mvr\_maxround 233
  - vol\_subdisk\_num 233
  - voldrl\_max\_drtregs 233
  - voldrl\_max\_seq\_dirty 37, 234
  - voldrl\_min\_regionsz 234
  - voliomem\_chunk\_size 234
  - voliomem\_maxpool\_sz 234
  - voliot\_errbuf\_default 234
  - voliot\_iobuf\_dflt 235
  - voliot\_iobuf\_limit 235
  - voliot\_iobuf\_max 235
  - voliot\_max\_open 236
  - volraid\_rsrtransmax 236
  - tutil 119
    - plex attribute 119
    - subdisk attribute 107
- U**
- UFS file systems
    - resizing 150
  - units
    - of size 101
  - use of FastResync
    - snapshots 37
  - use-nvramrc
    - EEPROM variable 57
  - usr volume
    - restrictions 52
- V**
- vaxassist
    - used to mirror across targets 132
  - versions
    - disk group 97
    - displaying for disk group 99
    - features supported by 98
    - upgrading 97
  - virtual objects 6
  - VM disks
    - defined 6
    - determining if shared 208
    - displaying spare 173
    - excluding free space from hot-relocation use 175
    - in cluster environments 193
    - initializing 44
    - making free space available for hot-relocation use 175
    - marking as spare 173
    - mirroring volumes on 145
    - moving volumes from 155
    - names 7
    - postponing replacement 63
    - removing from pool of hot-relocation spares 174
    - renaming 68
  - vol## 9
  - vol##-## 9
  - vol\_checkpoint\_default tunable 230
  - vol\_default\_iodelay tunable 230
  - vol\_fmr\_logsz tunable 39, 206, 230
  - vol\_max\_vol tunable 231
  - vol\_maxio tunable 231
  - vol\_maxioctl tunable 232
  - vol\_maxkiocount tunable 232
  - vol\_maxparallelio tunable 232
  - vol\_maxspecialio tunable 232
  - vol\_mvr\_maxround tunable 233
  - vol\_subdisk\_num tunable 233
  - volatile devices 59
  - voldrl\_max\_drtregs tunable 233
  - voldrl\_max\_seq\_dirty tunable 37, 234
  - voldrl\_min\_regionsz tunable 234
  - voliomem\_chunk\_size tunable 234
  - voliomem\_maxpool\_sz tunable 234
  - voliot\_errbuf\_default tunable 234
  - voliot\_iobuf\_dflt tunable 235
  - voliot\_iobuf\_limit tunable 235
  - voliot\_iobuf\_max tunable 235
  - voliot\_max\_open tunable 236
  - volraid\_rsrtransmax tunable 236
  - volume kernel states
    - DETACHED 140
    - DISABLED 140
    - ENABLED 140
  - volume resynchronization 34
  - volume states
    - ACTIVE 138
    - CLEAN 138
    - EMPTY 139
    - NEEDSYNC 139
    - REPLAY 139
    - SYNC 139
  - volumes



---

- accessing device files 136
- adding DRL logs 147
- adding mirrors 144
- adding RAID-5 logs 148
- adding sequential DRL logs 147
- adding subdisks to plexes of 105
- advanced approach to creating 123
- assisted approach to creating 123
- associating plexes with 115
- attaching plexes to 115
- backing up 157
- backing up online using snapshots 159
- block device files 136
- booting root 52
- boot-time restrictions 52
- changing layout online 163
- changing number of columns 163
- changing read policies for mirrored 153
- changing stripe unit size 163
- character device files 136
- combining mirroring and striping for performance 221
- combining online relayout and conversion 166
- concatenated 13, 121
- concatenated-mirror 21, 122
- Concatenated-Pro 122
- configuring exclusive open by cluster node 211
- converting between layered and non-layered 166
- converting concatenated-mirror to mirrored-concatenated 166
- converting mirrored-concatenated to concatenated-mirror 166
- converting mirrored-stripe to striped-mirror 166
- converting striped-mirror to mirrored-stripe 166
- creating 123
- creating concatenated-mirror 129
- creating from snapshots 162
- creating mirrored 129
- creating mirrored-concatenated 129
- creating mirrored-stripe 131
- creating RAID-5 132
- creating snapshots 160
- creating striped 130
- creating striped-mirror 131
- creating using vxmake 133
- creating using vxmake description file 135
- creating with DRL logging enabled 130
- creating with sequential DRL enabled 130
- defined 9
- detaching plexes from temporarily 116
- disabling FastResync on mirrors 157
- disconnecting plexes 115
- displaying information 137
- displaying information about snapshots 162
- dissociating plexes from 118
- enabling FastResync on mirrors 156
- excluding storage from use by vxassist 128
- finding maximum size of 127
- finding out by how much can grow 149
- flagged as dirty 35
- initializing 136
- initializing contents to zero 136
- kernel states 140
- layered 20, 27, 122
- limit on number of plexes 9
- limitations 9
- listing on boot (root) disk 57
- maximum number of 231
- maximum number of data plexes 222
- merging snapshots 161
- mirrored 18, 122
- mirrored-concatenated 19
- mirrored-stripe 19, 122
- mirroring across controllers 132
- mirroring across targets 132
- mirroring all 145
- mirroring on disks 145
- moving from VM disks 155
- moving to improve performance 226
- names 9
- naming snap 40
- obtaining performance statistics 224
- performance of mirrored 220
- performance of RAID-5 221
- performance of striped 220
- performing online relayout 163
- placing in maintenance mode 143
- preventing recovery on restarting 144
- RAID-0 15



---

- RAID-0+1 19
- RAID-1 18
- RAID-1+0 20
- RAID-10 20
- RAID-5 22, 122
- raw device files 136
- reattaching plexes 116
- reconfiguration in clusters 198
- recovering after correctable hardware failure 170
- removing 154
- removing DRL logs 147
- removing from /etc/vfstab 154
- removing mirrors from 146
- removing RAID-5 logs 148
- removing sequential DRL logs 147
- resizing 149
- resizing using vxassist 151
- resizing using vxresize 150
- resizing using vxvol 152
- resynchronizing from snapshots 162
- spanned 13
- specifying default layout 127
- specifying non-default number of columns 130
- specifying non-default relayout 163
- specifying non-default stripe unit size 130
- specifying use of storage to vxassist 128
- starting 136, 144
- states 138
- stopping 143
- stopping activity on 154
- striped 15, 121
- striped-mirror 20, 122
- Striped-Pro 122
- striping to improve performance 227
- swap restrictions 52
- taking multiple snapshots 40
- tracing operations 223
- trigger point for mirroring in striped-mirror 131
- types of layout 121
- usr restrictions 52
- VRTExplorer xviii
- vxassist
  - advantages of using 124
  - command usage 125
  - defaults file 125
  - setting default values 125
  - snapback 38
  - snapclear 38
  - snapshot 38
  - snapstart 38
  - used to add a log subdisk 106
  - used to add a RAID-5 log 148
  - used to add DRL logs 147
  - used to add mirrors to volumes 115, 144
  - used to add sequential DRL logs 147
  - used to change number of columns 163
  - used to change stripe unit size 163
  - used to configure exclusive access to a volume 211
  - used to convert between layered and non-layered volumes 166
  - used to create concatenated-mirror volumes 129
  - used to create mirrored volumes 129
  - used to create mirrored-concatenated volumes 129
  - used to create mirrored-stripe volumes 131
  - used to create RAID-5 volumes 132
  - used to create snapshots 159
  - used to create striped volumes 130
  - used to create striped-mirror volumes 131
  - used to create volumes 124
  - used to define layout on specified storage 128
  - used to disable FastResync 157
  - used to discover maximum volume size 127
  - used to display information about snapshots 162
  - used to dissociate snapshots from volumes 162
  - used to enable FastResync 156
  - used to exclude storage from use 128
  - used to find out by how much volumes can grow 149
  - used to merge snapshots with volumes 162
  - used to mirror across controllers 132
  - used to mirror file systems on root disk 57
  - used to move subdisks after hot-relocation 178



- used to move volumes 226
- used to layout volumes online 163
- used to remove DRL logs 147
- used to remove mirroring 146
- used to remove RAID-5 logs 149
- used to remove volumes 154
- used to reserve disks 68
- used to resize volumes 151
- used to resynchronize volumes from snapshots 162
- used to snapshot multiple volumes 161
- used to specify number of mirrors 129
- used to specify number of RAID-5 logs 133
- used to specify plexes for online relayout 164
- used to specify sequential DRL logging 130
- used to specify storage attributes 128
- used to specify tags for online relayout tasks 164
- used to unrelocate subdisks after hot-relocation 178
- vxclust
  - cluster reconfiguration utility used by nodes 212
- vxclustadm
  - controlling cluster functionality on nodes 213
- vxconfigd
  - managed using vxctl 99
  - operation in clusters 213
- vxctl
  - used in clusters 215
  - used to check cluster protocol version 216
  - used to enable disks after hot swap 67
  - used to manage vxconfigd 99
  - used to upgrade cluster protocol version 216
- vxdbg
  - used to add disks to disk groups forcibly 210
  - used to assign minor number ranges 94
  - used to change activation mode on shared disk groups 209
  - used to clear locks on disks 93
  - used to convert shared disk groups to private 209
  - used to create disk groups 85
  - used to create disk groups with old version number 99
  - used to create shared disk groups 208
  - used to deport disk groups 88
  - used to designate disk group as cluster-shareable 196
  - used to destroy disk groups 95
  - used to disable a disk group 94
  - used to display disk group version 99
  - used to display free space in disk groups 96
  - used to display information about disk groups 95
  - used to force import of disk groups 93
  - used to import disk groups 89
  - used to import disk groups forcibly 210
  - used to import shared disk groups 209
  - used to list shared disk groups 210
  - used to list spare disks 173
  - used to move disk groups between systems 92
  - used to move disks between disk groups 91
  - used to obtain copy size of configuration database 83
  - used to remove disks from disk groups 86
  - used to rename disk groups 90
  - used to upgrade disk group version 99
- vxdisk
  - used to clear locks on disks 93
  - used to determine if disks are shared 208
  - used to display information about disks 96
  - used to display multipathing information 70
  - used to list disks 69
  - used to list spare disks 173
  - used to take disks offline 67
- vxdiskadd 51
  - used to add disks to disk groups 85
  - used to create disk groups 85
- vxdiskadm 52
  - Add or initialize one or more disks 46, 85
  - Disable (offline) a disk device 67
  - Enable (online) a disk device 66
  - Enable access to (import) a disk group 88
  - Encapsulate one or more disks 54



- Exclude a disk from hot-relocation use 175
- List disk information 71
- Make a disk available for hot-relocation use 176
- Mark a disk as a spare for a disk group 174
- Mirror volumes on a disk 145
- Move volumes from a disk 155
- Remove a disk 60, 86
- Remove a disk for replacement 63
- Remove access to (deport) a disk group 87
- Replace a failed or removed disk 65
- Unrelocate subdisks back to a disk 177
  - used to add disks 46
  - used to add disks to disk groups 85
  - used to create disk groups 85
  - used to deport disk groups 87
  - used to exclude free space on disks from hot-relocation use 175
  - used to import disk groups 88
  - used to initialize disks 46
  - used to list spare disks 173
  - used to make free space on disks available for hot-relocation use 176
  - used to mark disks as spare 174
  - used to mirror volumes 145
  - used to move disk groups between systems 93
  - used to move disks between disk groups 91
  - used to move subdisks after hot-relocation 177
  - used to move subdisks from disks 86
  - used to move volumes from VM disks 155
  - used to unrelocate subdisks after hot-relocation 177
- vxdmpadm
  - used to disable controllers 189, 190
  - used to disable controllers in DMP 186
  - used to display a DMP node for a path 187
  - used to display a DMP node for an enclosure 187
  - used to display DMP database information 186
  - used to display paths controlled by DMP node 188
  - used to display status of DMP error daemons 191
  - used to display status of DMP restore daemon 191
  - used to enable controllers in DMP 186
  - used to list controllers 188
  - used to list enclosures 189
  - used to rename enclosures 190
  - used to set restore polling interval 190
  - used to specify DMP restore policy 190
  - used to start DMP restore daemon 190
  - used to stop DMP restore daemon 191
- vxedit 119
  - used to change plex attributes 119
  - used to change subdisk attributes 107
  - used to configure number of configuration copies for a disk group 229
  - used to exclude free space on disks from hot-relocation use 175
  - used to make free space on disks available for hot-relocation use 176
  - used to mark disks as spare 173
  - used to remove disks from pool of hot-relocation spares 174
  - used to remove plexes 119
  - used to remove subdisks from VxVM 106
  - used to remove volumes 154
  - used to rename disks 68
  - used to reserve disks 68
  - used to set disk connectivity policy in a cluster 209
- VxFS file systems
  - resizing 150
- vxmake
  - used to associate plexes with volumes 115
  - used to associate subdisks with new plexes 104
  - used to create plexes 109, 144
  - used to create striped plexes 110
  - used to create subdisks 101
  - used to create volumes 133
  - using description file with 135
- vxmend
  - used to put plexes online 143
  - used to re-enable plexes 116
  - used to take plexes offline 115, 143



- 
- vxmirror
    - used to configure VxVM default behavior 145
    - used to mirror root disk 56
    - used to mirror volumes 145
    - used to mirror volumes on boot (root) disk 57
  - vxplex
    - used to add a RAID-5 log 148
    - used to attach plexes to volumes 115, 144
    - used to copy plexes 118
    - used to detach plexes temporarily 116
    - used to dissociate and remove plexes 118
    - used to dissociate plexes from volumes 119
    - used to move plexes 117
    - used to reattach plexes 116
    - used to remove mirror plexes 146
    - used to remove RAID-5 logs 149
  - vxprint
    - used to display plex information 110
    - used to display subdisk information 102
    - used to display volume information 137
    - used to identify RAID-5 log plexes 148
    - used to list spare disks 173
    - used to list volumes on boot disk 57
  - vxrecover
    - used to prevent recovery 144
    - used to recover plexes 170
    - used to restart a volume 144
  - vxrelayout
    - used to resume online relayout 165
    - used to reverse direction of online relayout 165
    - used to view status of online relayout 164
  - vxrelocd
    - hot-relocation daemon 168
    - modifying behavior of 181
    - notifying users other than root 182
    - operation of 168
    - reducing performance impact of recovery 182
  - vxresize
    - used to grow volumes and file systems 150
    - used to shrink volumes and file systems 150
  - vxsd
    - used to add log subdisk 105
    - used to add subdisks to RAID-5 plexes 105
    - used to add subdisks to striped plexes 105
    - used to associate subdisks with existing plexes 104
    - used to dissociate subdisks 106
    - used to fill in sparse plexes 104
    - used to join subdisks 103
    - used to move subdisk contents 102
    - used to remove subdisks from VxVM 106
    - used to split subdisks 103
  - VxSmartSync 41
  - vxstat
    - used to determine failed disk 170
    - used to obtain disk performance statistics 226
    - used to obtain volume performance statistics 224
    - used with clusters 217
    - zeroing counters 225
  - vxtask
    - used to abort tasks 143
    - used to lists tasks 142
    - used to monitor online relayout 165
    - used to monitor tasks 142
    - used to pause online relayout 165
    - used to resume online relayout 165
    - used to resume tasks 142
  - vxtrace
    - used to trace volume operations 223
  - vxunreloc
    - restarting after errors 181
    - used to list original disks of hot-relocated subdisks 180
    - used to move subdisks after hot-relocation 179
    - used to specify different offsets for unrelocated subdisks 180
    - used to unrelocate subdisks after hot-relocation 179
    - used to unrelocate subdisks to different disks 179
  - VxVM
    - benefits to performance 219
    - cluster functionality 193
    - configuration daemon 99



---

configuring to create mirrored volumes 145  
dependency on operating system 2  
granularity of memory allocation by 234  
limitations of shared disk groups 195  
maximum number of data plexes per volume 222  
maximum number of nodes in cluster 193  
maximum number of subdisks per plex 233  
maximum number of volumes 231  
maximum size of memory pool 234  
objects in 6  
obtaining system information xviii  
operation in clusters 195  
performance tuning 228  
rootability 51  
shared objects in cluster 194  
size units 101  
task monitor 140  
types of volume layout 121  
upgrading 97  
upgrading disk group version 99

**vxvol**  
used to configure exclusive access to a volume 211  
used to disable FastResync 157  
used to enable FastResync 156  
used to initialize volumes 136  
used to put volumes in maintenance mode 143  
used to resize logs 152  
used to resize volumes 152  
used to set read policy 153  
used to start volumes 136, 144  
used to stop volumes 143, 154  
used to zero out volumes 136

