

# **z/VM and Linux Operations for z/OS System Programmers**

**An introduction to z/VM and Linux for  
z/OS programmers**

**Migrate z/OS to a z/VM guest  
system**

**Install and manage Linux  
on System z**

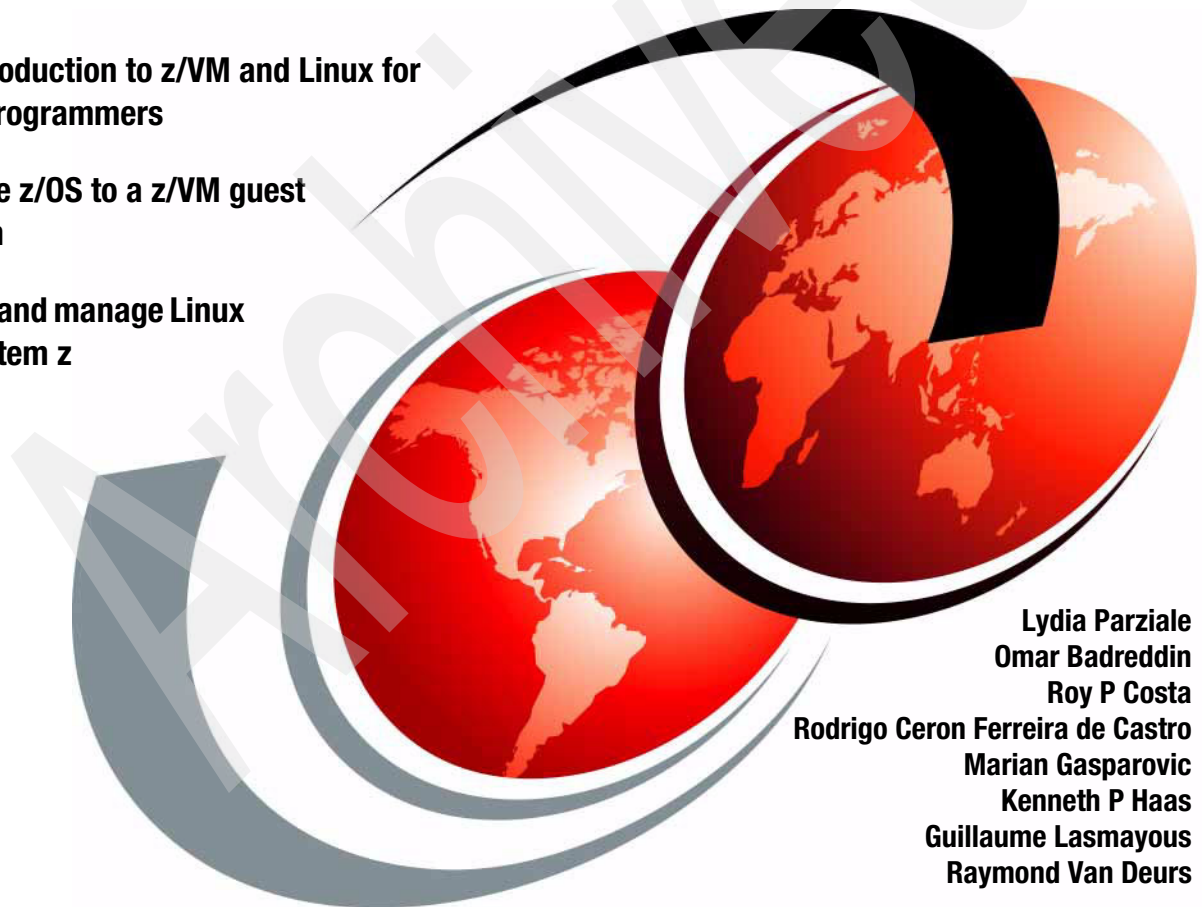

**Lydia Parziale  
Omar Badreddin  
Roy P Costa  
Rodrigo Ceron Ferreira de Castro  
Marian Gasparovic  
Kenneth P Haas  
Guillaume Lasmayous  
Raymond Van Deurs**





International Technical Support Organization

**z/VM and Linux Operations for z/OS System  
Programmers**

October 2008

Archived

**Note:** Before using this information and the product it supports, read the information in “Notices” on page ix.

**First Edition (October 2008)**

This edition applies to z/VM Version 5, Release 3, modification 0 (product number 5741-A05).

**© Copyright International Business Machines Corporation 2008. All rights reserved.**

Note to U.S. Government Users Restricted Rights -- Use, duplication or disclosure restricted by GSA ADP Schedule Contract with IBM Corp.

# Contents

<b>Notices</b> .....	ix
Trademarks .....	x
<b>Preface</b> .....	xi
The team that wrote this book .....	xi
Become a published author .....	xiii
Comments welcome .....	xiii
<b>Chapter 1. Why z/VM and Linux for System z?</b> .....	1
1.1 Why z/VM? .....	2
1.1.1 The Virtual Machine Capability of z/VM .....	2
1.1.2 z/VM offers proven system integrity, security, reliability .....	4
1.2 Why Linux? .....	4
1.3 Why Linux and z/OS together with z/VM? .....	5
1.3.1 Server simplification .....	5
1.3.2 Ten great reasons to run Linux as a guest of z/VM .....	7
<b>Chapter 2. Introducing z/VM to z/OS system programmers</b> .....	9
2.1 Overview of virtualization .....	10
2.1.1 Benefits of virtualization .....	10
2.1.2 How virtualization works .....	12
2.1.3 Virtualization on the mainframe .....	13
2.2 Overview of z/VM .....	13
2.2.1 History of z/VM .....	14
2.2.2 About z/VM .....	16
2.2.3 First-level versus second-level guest system .....	17
2.2.4 User directory .....	18
2.3 Components of z/VM .....	20
2.3.1 Control Program .....	21
2.3.2 Conversational Monitor System .....	21
2.3.3 TCP/IP .....	23
2.3.4 APPC/VM VTAM Support (AVS) .....	23
2.3.5 Dump Viewing Facility .....	24
2.3.6 Group Control System (GCS) .....	24
2.3.7 HCD and HCM for z/VM .....	24
2.3.8 Language Environment .....	25
2.3.9 OSA/SF .....	26
2.3.10 REXX/VM .....	26
2.3.11 TSAF .....	26

2.3.12	VMSES/E	27
2.3.13	DFSMS/VM	27
2.3.14	Directory Maintenance Facility for z/VM	28
2.3.15	Performance Toolkit for VM	29
2.3.16	RACF Security Server for z/VM	30
2.3.17	RSCS Networking for z/VM	31
2.4	Control Program (CP)	33
2.4.1	CP functions and concepts	33
2.4.2	CP modes of execution	35
2.5	Conversational Monitor System (CMS)	35
2.5.1	Overview of the HELP command in CMS	36
2.5.2	Layers (levels) of help	39
2.5.3	Other help options	42
2.5.4	Other ways to get help	42
2.5.5	Getting help for error messages	43
2.5.6	Tips for using the Help system	43
2.5.7	Exiting the Help system	44
2.6	Networking options in z/VM	44
2.6.1	OSA adapters	44
2.6.2	HiperSockets	44
2.6.3	HiperSockets for fast LPAR communication	46
2.6.4	VSWITCH	49
2.6.5	Further information about networking	50
2.7	Consoles	50
2.7.1	The Hardware Management Console	51
2.7.2	The primary system operator console	53
2.7.3	The z/VM virtual consoles	53
2.7.4	The virtual machine guest systems console	54
2.7.5	Getting to know your virtual console	54
2.7.6	Session management	59
2.7.7	Terminal management	62
2.8	Getting started with basic commands for z/VM	65
2.8.1	CP	66
2.8.2	CMS	72
2.8.3	XEDIT	77
<b>Chapter 3. Introducing Linux on System z to z/OS system programmers</b>		<b>95</b>
3.1	Overview of Linux	96
3.1.1	History of Linux	96
3.1.2	Components of Linux	97
3.1.3	Linux on System z distributions	97
3.2	Getting started with Linux	100
3.2.1	The file system and root user	100

3.2.2	Basic starting steps . . . . .	102
3.2.3	File permissions . . . . .	110
3.2.4	Job control . . . . .	114
3.2.5	Linux vi editor . . . . .	115
3.3	Exploring further . . . . .	120
<b>Chapter 4. Installing z/VM and creating Linux or z/OS guests . . . . .</b>		<b>121</b>
4.1	Initial installation of z/VM, compared to z/OS . . . . .	122
4.1.1	Installation methods and deliveries . . . . .	122
4.1.2	z/VM delivery . . . . .	122
4.1.3	z/OS deliveries . . . . .	122
4.1.4	Comparing a z/VM installation to z/OS installation types . . . . .	123
4.2	z/VM installation concepts and considerations . . . . .	124
4.2.1	Interacting with z/VM . . . . .	124
4.2.2	System files . . . . .	126
4.2.3	Important z/VM installation user IDs . . . . .	128
4.2.4	Dealing with disks . . . . .	129
4.3	Installing z/VM in an LPAR . . . . .	138
4.3.1	Planning . . . . .	138
4.3.2	Installing z/VM from DVD . . . . .	145
4.3.3	Relabeling the system volumes . . . . .	165
4.4	Installing Linux . . . . .	171
4.4.1	Configuring your z/VM system for installing Linux . . . . .	171
4.4.2	Booting the Linux kernel for installation . . . . .	199
4.4.3	Logging into the Linux system . . . . .	214
4.5	Running a z/OS image as a z/VM guest . . . . .	219
4.5.1	z/OS candidate description . . . . .	219
4.5.2	Necessary definitions for z/VM . . . . .	220
4.5.3	Defining z/OS guest in USER DIRECT . . . . .	220
4.5.4	ZOS1 guest console considerations . . . . .	222
4.5.5	SC59 guest PROFILE EXEC creation . . . . .	222
4.5.6	IPLing the system as a z/VM guest . . . . .	224
4.5.7	z/OS concerns . . . . .	224
4.5.8	Adding a 3390 disk to the z/OS guest . . . . .	225
<b>Chapter 5. z/VM system operations . . . . .</b>		<b>227</b>
5.1	Using a console to communicate to users . . . . .	228
5.1.1	Sending a general information message to all users . . . . .	228
5.1.2	Sending a general information message to a specific user . . . . .	229
5.1.3	Sending a warning message to all users . . . . .	229
5.1.4	Sending a warning message to a specific user . . . . .	230
5.2	Running the system . . . . .	230
5.2.1	z/VM IPL workflow . . . . .	230

5.2.2	Warm start, force start, cold start, and clean start	234
5.2.3	Checking system resources	237
5.2.4	z/VM shutdown workflow	246
5.2.5	z/VM services	247
5.3	Managing a guest operating system virtual machine	248
5.3.1	Guest support	249
5.3.2	Starting a guest operating system	249
5.3.3	Issuing CP commands while running a guest operating system	250
5.3.4	Pausing a guest operating system	251
5.3.5	Resuming a guest operating system	253
5.3.6	Halting a guest operating system	253
5.3.7	Managing CPUs	254
5.3.8	Managing storage (main memory)	256
5.3.9	Managing DASD	258
5.3.10	Spool devices	266
5.3.11	The CMS Shared File System	272
5.4	Job scheduling and running batch jobs	274
5.4.1	Job scheduling	275
5.4.2	Running batch jobs	276
5.5	Cloning	279
5.6	Monitoring the system	280
5.7	Backing up data	280
5.8	Maintaining the system	280
5.9	Debugging the system	281
	<b>Chapter 6. System administration</b>	<b>283</b>
6.1	Managing z/VM security	284
6.1.1	User authentication	284
6.1.2	User authorization	285
6.1.3	Intrusion detection	286
6.1.4	Virtual processors security	286
6.1.5	z/VM privilege classes	287
6.1.6	System user IDs involved in security	289
6.1.7	Security relevant statements	289
6.1.8	Resource Access Control Facility (RACF)	291
6.2	Defining users	292
6.2.1	z/OS assumptions	292
6.2.2	Defining users in z/VM	294
6.2.3	USER DIRECT from a z/OS perspective	295
6.2.4	USER DIRECT definitions	295
6.2.5	DISKMAP command	296
6.2.6	Creating and maintaining the USER DIRECT source file	297
6.3	Networking access	301



6.4 Linux on System z resource management . . . . .	301
6.4.1 Hardware detection and configuration . . . . .	301
6.4.2 Disk management . . . . .	303
6.4.3 Network management . . . . .	309
6.4.4 CPU management . . . . .	315
<b>Chapter 7. Performance monitoring and system analysis . . . . .</b>	<b>319</b>
7.1 Monitoring z/VM . . . . .	320
7.1.1 z/VM scheduling . . . . .	320
7.1.2 CP monitoring commands . . . . .	323
7.2 Tuning basics . . . . .	336
7.2.1 System tuning approach . . . . .	336
7.2.2 Where tuning can help . . . . .	336
7.2.3 Where tuning does not help . . . . .	337
7.3 Performance and Monitoring tools for z/VM . . . . .	338
7.3.1 IBM Performance Toolkit for VM . . . . .	338
7.3.2 Tivoli OMEGAMON for z/VM and Linux . . . . .	339
7.3.3 IBM Tivoli Performance Modeler . . . . .	340
7.3.4 IBM z/VM Planner for Linux guests on IBM System z Processors . . . . .	341
7.3.5 Tivoli Workload Scheduling Suite . . . . .	342
7.3.6 Tuning memory for z/VM Linux guests . . . . .	343
7.3.7 Execute-in-place technology . . . . .	344
7.4 Monitoring your Linux guests . . . . .	345
7.4.1 The vmstat command . . . . .	346
7.4.2 The pstree command . . . . .	346
7.4.3 The top Command . . . . .	347
7.4.4 System status (sysstat) tool . . . . .	348
7.4.5 The OProfile tool . . . . .	348
<b>Chapter 8. System events and logs, backup and recovery . . . . .</b>	<b>351</b>
8.1 z/VM and Linux error handling . . . . .	352
8.1.1 z/VM default error handling . . . . .	352
8.1.2 z/VM error codes . . . . .	353
8.1.3 Linux error handling . . . . .	355
8.1.4 Linux error codes . . . . .	355
8.2 z/VM tools for error gathering and analysis . . . . .	356
8.2.1 Collecting information about system events . . . . .	356
8.2.2 Collecting information about errors . . . . .	361
8.2.3 Dumps and traces . . . . .	365
8.3 Linux activity logging and error analysis . . . . .	368
8.3.1 Linux activity logging . . . . .	368
8.3.2 Error analysis tools . . . . .	372
8.4 Backup and restore . . . . .	374

8.4.1 z/VM offline backups . . . . .	375
8.4.2 z/VM online backups . . . . .	379
8.4.3 Linux backup tools . . . . .	381
8.4.4 Other available tools . . . . .	386
<b>Chapter 9. Applying system maintenance . . . . .</b>	<b>387</b>
9.1 Servicing differences between z/VM and z/OS . . . . .	388
9.2 z/VM maintenance methods . . . . .	388
9.3 VMSES/E terminology . . . . .	389
9.3.1 Deliveries . . . . .	389
9.3.2 Element terms . . . . .	389
9.3.3 BUILD process . . . . .	390
9.4 Comparing VMSES/E and SMP/E . . . . .	390
9.4.1 Installing COR service . . . . .	391
9.4.2 Product Service Upgrade (PSU) . . . . .	392
9.5 Convenient maintenance practices for z/VM . . . . .	394
9.6 Case study . . . . .	395
9.6.1 Invoking PUT2PROD . . . . .	397
9.6.2 Installing additional PTFs . . . . .	397
9.7 Putting your serviced z/VM into production . . . . .	398
<b>Appendix A. Cross reference: z/OS, z/VM, and Linux commands . . . . .</b>	<b>399</b>
<b>Appendix B. Planning worksheet . . . . .</b>	<b>403</b>
<b>Related publications . . . . .</b>	<b>405</b>
IBM Redbooks . . . . .	405
Other publications . . . . .	405
Online resources . . . . .	406
How to get Redbooks . . . . .	408
Help from IBM . . . . .	408
<b>Index . . . . .</b>	<b>409</b>

# Notices

This information was developed for products and services offered in the U.S.A.

IBM may not offer the products, services, or features discussed in this document in other countries. Consult your local IBM representative for information on the products and services currently available in your area. Any reference to an IBM product, program, or service is not intended to state or imply that only that IBM product, program, or service may be used. Any functionally equivalent product, program, or service that does not infringe any IBM intellectual property right may be used instead. However, it is the user's responsibility to evaluate and verify the operation of any non-IBM product, program, or service.

IBM may have patents or pending patent applications covering subject matter described in this document. The furnishing of this document does not give you any license to these patents. You can send license inquiries, in writing, to:  
*IBM Director of Licensing, IBM Corporation, North Castle Drive, Armonk, NY 10504-1785 U.S.A.*

**The following paragraph does not apply to the United Kingdom or any other country where such provisions are inconsistent with local law:** INTERNATIONAL BUSINESS MACHINES CORPORATION PROVIDES THIS PUBLICATION "AS IS" WITHOUT WARRANTY OF ANY KIND, EITHER EXPRESS OR IMPLIED, INCLUDING, BUT NOT LIMITED TO, THE IMPLIED WARRANTIES OF NON-INFRINGEMENT, MERCHANTABILITY OR FITNESS FOR A PARTICULAR PURPOSE. Some states do not allow disclaimer of express or implied warranties in certain transactions, therefore, this statement may not apply to you.

This information could include technical inaccuracies or typographical errors. Changes are periodically made to the information herein; these changes will be incorporated in new editions of the publication. IBM may make improvements and/or changes in the product(s) and/or the program(s) described in this publication at any time without notice.

Any references in this information to non-IBM Web sites are provided for convenience only and do not in any manner serve as an endorsement of those Web sites. The materials at those Web sites are not part of the materials for this IBM product and use of those Web sites is at your own risk.

IBM may use or distribute any of the information you supply in any way it believes appropriate without incurring any obligation to you.

Information concerning non-IBM products was obtained from the suppliers of those products, their published announcements or other publicly available sources. IBM has not tested those products and cannot confirm the accuracy of performance, compatibility or any other claims related to non-IBM products. Questions on the capabilities of non-IBM products should be addressed to the suppliers of those products.

This information contains examples of data and reports used in daily business operations. To illustrate them as completely as possible, the examples include the names of individuals, companies, brands, and products. All of these names are fictitious and any similarity to the names and addresses used by an actual business enterprise is entirely coincidental.

## COPYRIGHT LICENSE:

This information contains sample application programs in source language, which illustrate programming techniques on various operating platforms. You may copy, modify, and distribute these sample programs in any form without payment to IBM, for the purposes of developing, using, marketing or distributing application programs conforming to the application programming interface for the operating platform for which the sample programs are written. These examples have not been thoroughly tested under all conditions. IBM, therefore, cannot guarantee or imply reliability, serviceability, or function of these programs.

# Trademarks

IBM, the IBM logo, and [ibm.com](http://www.ibm.com) are trademarks or registered trademarks of International Business Machines Corporation in the United States, other countries, or both. These and other IBM trademarked terms are marked on their first occurrence in this information with the appropriate symbol (® or ™), indicating US registered or common law trademarks owned by IBM at the time this information was published. Such trademarks may also be registered or common law trademarks in other countries. A current list of IBM trademarks is available on the Web at <http://www.ibm.com/legal/copytrade.shtml>

The following terms are trademarks of the International Business Machines Corporation in the United States, other countries, or both:

AIX®	NetView®	System z®
AS/400®	OMEGAMON®	SystemPac®
BookManager®	OS/390®	SystemView®
DB2®	Parallel Sysplex®	Tivoli®
developerWorks®	POWER™	VSE/ESA™
DFSMS™	PR/SM™	VTAM®
DFSMS/VM™	RACF®	WebSphere®
DFSMSdss™	Redbooks®	Workplace™
DirMaint™	Redbooks (logo)  ®	z/Architecture®
DS8000™	REXX™	z/OS®
ECKD™	RMF™	z/VM®
eServer™	S/390®	z/VSE™
HiperSockets™	SAA®	z10™
IBM®	System Storage™	z9®
Language Environment®	System z10™	zSeries®
MVS™	System z9®	

The following terms are trademarks of other companies:

Carta, and Portable Document Format (PDF) are either registered trademarks or trademarks of Adobe Systems Incorporated in the United States, other countries, or both.

NOW, and the NetApp logo are trademarks or registered trademarks of NetApp, Inc. in the U.S. and other countries.

Novell, SUSE, the Novell logo, and the N logo are registered trademarks of Novell, Inc. in the United States and other countries.

Oracle, JD Edwards, PeopleSoft, Siebel, and TopLink are registered trademarks of Oracle Corporation and/or its affiliates.

Java, and all Java-based trademarks are trademarks of Sun Microsystems, Inc. in the United States, other countries, or both.

Microsoft, Windows, and the Windows logo are trademarks of Microsoft Corporation in the United States, other countries, or both.

UNIX is a registered trademark of The Open Group in the United States and other countries.

Linux is a trademark of Linus Torvalds in the United States, other countries, or both.

Other company, product, or service names may be trademarks or service marks of others.

# Preface

This IBM® Redbooks® publication discusses z/VM® and Linux® operations from the perspective of the z/OS® programmer or system programmer. Although other books have been written about many of these topics, this book gives enough information about each topic to describe z/VM and Linux on IBM System z® operations to somebody who is new to both environments.

This book is intended for z/OS programmers and system programmers who are transitioning to the z/VM and Linux on System z environments and who want a translation guide for assistance.

We base this book on our experiences using System z10™ Enterprise Edition, z/VM version 5.3 RSU 0701, and Novell® SUSE® Linux Enterprise Server (SLES) 10 on System z.

## The team that wrote this book

This book was produced by a team of specialists from around the world working at the International Technical Support Organization, Poughkeepsie Center.

**Lydia Parziale** is a Project Leader for the ITSO team in Poughkeepsie, New York, with domestic and international experience in technology management including software development, project leadership, and strategic planning. Her areas of expertise include e-business development and database management technologies. Lydia is a PMP and an IBM Certified IT Specialist with an MBA in Technology Management, and has been employed by IBM for over 20 years in various technology areas.

**Omar Badreddin** is a Researcher at the IBM Center for Advanced Studies and Research in Ottawa and a member of Complexity Reduction in Software Engineering research group (CRuiSE). Omar has five years of work experience with IBM as a Software Engineer and has delivered a number of ITSO workshops. His area of expertise includes virtualization, modeling, BPM, SOA, and software globalization.

**Roy P Costa** is an Advisory Systems Programmer at the IBM International Technical Support Organization, Poughkeepsie Center. He has over 25 years of experience in z/VM systems operation and programming. Roy has worked with Linux on System z for more than five years and has authored several Redbooks

and Redpaper publications. For the past 13 years, he has been provided technical advice and support to numerous IBM Redbooks publications.

**Rodrigo Ceron Ferreira de Castro** has worked at the IBM Linux Technology Center in Brazil since 2004 and leads the development of the IBM Installation Toolkit for Linux on POWER™ project. He has given many presentations about Linux and Operations Research in conferences worldwide. He holds four patents in the United States Patent and Trademark Office in related fields. Rodrigo is one of the first IEEE Certified Software Development Associates (CSDA) in the world.

**Marian Gasparovic** is an IT Specialist working for IBM Server and Technology group in IBM Slovakia. He worked as an Administrator for z/OS at Business Partner for six years. He joined IBM in 2004 as a storage specialist. Currently, he holds dual roles: Field Technical Sales Support for System z in the CEMAAS region as a member of a new workload team; and for ITSO in Poughkeepsie, NY.

**Kenneth P Haas** is a Field Technical Sales Specialist (FTSS) in Atlanta, Georgia with the East Region Technical WebSphere® Software Sales group. He recently graduated from Furman University in Greenville, South Carolina with dual degrees in Computer Science and Business Management. Joining IBM a year ago, he has been a part of the IBM vitality hire program spending a full year training in his specialties, which include z/VM and Linux, and a range of WebSphere Products on System z.

**Guillaume Lasmayous** is an IT Specialist at the New Technology Center in Montpellier, France. He has several years of experience in the mainframe area. He is working as a pre-sales technical specialist, supporting customers who run new workloads on System z. His area of expertise includes z/VM, Linux, and a range of middleware supported in this environment.

**Raymond Van Deurs** is a z/OS System Programmer at EDB Business Partner ASA in Norway. He has 26 years of experience in the IBM mainframe area.

Thanks to the following people for their contributions to this project:

Sylvain Carta® and Mathieu Dalbin  
IT Specialists in Montpellier, France

Rich Conway and Robert Haimowitz  
International Technical Support Organization, Poughkeepsie Center

Lionel B. Dyck, Mainframe Consultant and Specialist  
KP-IT Enterprise Engineering

Ivan Dobos, IBM System z Specialist  
IBM Sales & Distribution, STG Sales

Special thanks to the authors of the IBM Redbooks publication, *Introduction to the New Mainframe: z/VM Basics*, SG24-7316, published in November, 2007:

Edi Lopes Alves, Eli M Dow, Klaus Egeler, Jason Herne, Clive Jordan, Eravimangalath P Naveen, Manoj S Pattabhiraman, and Kyle Smith

## Become a published author

Join us for a two- to six-week residency program! Help write a book dealing with specific products or solutions, while getting hands-on experience with leading-edge technologies. You will have the opportunity to team with IBM technical professionals, Business Partners, and Clients.

Your efforts will help increase product acceptance and customer satisfaction. As a bonus, you will develop a network of contacts in IBM development labs, and increase your productivity and marketability.

Find out more about the residency program, browse the residency index, and apply online at:

[ibm.com/redbooks/residencies.html](http://ibm.com/redbooks/residencies.html)

## Comments welcome

Your comments are important to us!

We want our books to be as helpful as possible. Send us your comments about this book or other IBM Redbooks in one of the following ways:

- ▶ Use the online **Contact us** review Redbooks form found at:

[ibm.com/redbooks](http://ibm.com/redbooks)

- ▶ Send your comments in an e-mail to:

[redbooks@us.ibm.com](mailto:redbooks@us.ibm.com)

- ▶ Mail your comments to:

IBM Corporation, International Technical Support Organization  
Dept. HYTD Mail Station P099  
2455 South Road  
Poughkeepsie, NY 12601-5400

Archived





# Why z/VM and Linux for System z?

In this chapter, we explore the benefits of using z/VM and Linux on System z and how you can exploit these benefits.

## Objectives

After completing this chapter, you should be able to:

- ▶ List the benefits z/VM can provide to your IT shop
- ▶ Understand why companies are investing in z/VM and Linux on System z

## 1.1 Why z/VM?

z/VM provides businesses with the ability to take full advantage of their IT resources by optimizing their utilization through virtualization. With over 40 years of experience, z/VM has become a leader in the field of virtualization. This section discusses the benefits of using that z/VM experience to support your IT infrastructure.

### 1.1.1 The Virtual Machine Capability of z/VM

z/VM presents a unique approach to computer operating systems. It provides each user with an individual working environment known as a virtual machine (VM). The virtual machine uses virtualization to simulate the existence of a real machine by sharing resources of a real machine, which include processors, storage, memory, and input/output (I/O) resources.

Operating systems and application programs can run in virtual machines as guests. For example, you can run multiple Linux and z/OS images on the same z/VM system that is also supporting various applications and users. As a result, development, testing, and production environments can share a single physical computer.

The virtual machine capability of z/VM allows you to perform the following tasks:

- ▶ Test the programs that can cause abnormal termination of real machine operations without affecting the processing of production work that is running simultaneously.

The isolation that is provided for a virtual machine enables system-oriented programs and teleprocessing applications, for example, to be tested on the virtual machine while production work is in progress; this testing cannot cause abnormal termination of the real machine.

- ▶ Test a new release of an operating system.

A new release of an operating system can be generated and tested at the same time that the existing release is performing production work. This enables the new release to be installed and put into production more quickly. The ability to operate multiple operating systems concurrently under z/VM can enable an installation to continue running programs that operate only under a back-level release (programs that are release-sensitive and uneconomical to convert, for example) concurrently with the most current release.

- ▶ Test a new operating system.  
The existing operating system can be used to process production work concurrently with the generation and testing of a new operating system. Experience with the new system can be obtained before it is used on a production basis, without dedicating the real machine to this function.
- ▶ Perform operating system maintenance concurrently with production work.  
The installation and testing of program temporary fixes (PTFs) for an operating system can be done at the same time that normal production operations are in progress.
- ▶ Provide backup facilities for the primary operating system.  
A generated z/VM system is not model-dependent and can operate on various server models if the minimum hardware requirements are present. This enables a smaller server model that has less real storage, fewer channels, fewer direct access devices, and fewer unit record devices than a larger server model to provide backup for the larger model (normally at a reduced level of performance).
- ▶ Perform operator training concurrently with production work processing.  
The real machine does not have to be dedicated to training additional or new operators or to providing initial training when a new operating system is installed. Operator errors cannot cause termination of real machine operations.
- ▶ Simulate new system configurations before the installation of additional channels and I/O devices.  
The relative load on channels and I/O devices can be determined by using the simulated I/O configuration rather than the real I/O configuration. Experience with generating and operating an I/O configuration for multiple guests can be obtained using one real machine.
- ▶ Test customer-written system exits.  
Customer-written system exits can be tested without disrupting production work.
- ▶ Provide the same hardware configuration for guest operating systems  
The consistence of the same hardware means the use of the same drivers everywhere, so testing many different drivers is unnecessary. This reduces the amount of testing and configuration for different guest systems.

## 1.1.2 z/VM offers proven system integrity, security, reliability

z/VM is built on a foundation of system integrity and security, and incorporates many design features for reliability and availability:

- ▶ Integrity and security:
  - z/VM supports guest use of the cryptographic facilities provided by supported IBM servers.
  - IBM will correct any integrity exposures introduced by unauthorized programs into the system.
  - Kerberos authentication and Secure Sockets Layer (SSL) support are provided through TCP/IP for z/VM.
  - Integrated access control and authentication services can be augmented with the addition of the RACF® for z/VM feature or other external security managers.
- ▶ Availability and reliability:
  - In application recovery, z/VM provides services that permit recovery of incomplete interactions with resource managers.
  - In automated operations, z/VM offers several levels of automated system management support. One example is the Programmable Operator. For a higher degree of automation, IBM SystemView® Host Management Facilities/VM can be added. Both the Programmable Operator and Host Management Facilities/VM can interact with IBM NetView® on z/VM, which in turn can interact with NetView on z/OS.
  - z/VM provides duplexed data with transparent ongoing synchronization between the primary and backup copy, and automatic transparent switching to the backup copy in case of an error in the primary copy.
  - Online configuration changes eliminate many previously required outages.
  - z/VM systems can be connected for improved server and user availability.
  - Fast restart from an outage reduces the effect on users.

## 1.2 Why Linux?

Linux on System z is all about helping to remove complexity from your IT infrastructure: reducing server sprawl; keeping a lid on software licensing fees; and minimizing the need for human intervention in managing and maintaining your servers.

## Open Source

IBM is committed to open source as both a license and a development model for several reasons:

- ▶ IBM clients and partners have requested open source software (including Linux) support for all IBM platforms, products, and solutions.
- ▶ Open source software, with its wide distribution and use, typically becomes an industry standard.
- ▶ Innovation within the open source community typically occurs at a higher rate and volume than in closed-source communities.

## Linux Technology Center (LTC)

IBM is a major contributor to the open source community, with over 250 developers worldwide working full time on many initiatives. One initiative is the Linux Technology Center (LTC), which enable the enterprise capabilities of Linux through development and contribution of technology, utilities, tools, and code.

To learn more about the LTC go to:

<http://oss.software.ibm.com/linux>

## 1.3 Why Linux and z/OS together with z/VM?

This section looks at using z/VM in combination with Linux on System z and z/OS. Because z/VM provides a highly flexible test and production environment, it is an easy way to deploy a fully functional operating system, such as Linux, on System z or z/OS. This allows for server simplification through server consolidation.

### 1.3.1 Server simplification

As companies have grown, their IT infrastructures have also grown. This has caused most companies to increase their number of stand-alone servers, storage devices, and applications. The increase can lead to enormous inefficiency issues and system management headaches.

The growth and its results have lead companies to employ server simplification using virtualization. In simple terms, *virtualization* offers a way to help consolidate a large number of individual small machines on one larger server, easing manageability and more efficiently using system resources. The resources can then be prioritized and allocated to the workloads needing them

most at any given time. As a result, you can reduce the need to over-provision for individual workload spikes. For more information see:

<http://www-03.ibm.com/systems/z/advantages/virtualization/index.html>

### **Server simplification outside System z**

With the ability to run Linux on System z, information technology departments are able to simplify their processes by consolidating their multiple server farms down to a single System z running z/VM and Linux on System z. This leads to both hardware savings and power savings, and it simplifies the management of your infrastructure, freeing up various IT resources so you can focus on mission-critical tasks.

Using virtualization, the ability to bring up Linux systems takes a matter of minutes rather than days waiting for new hardware and the installation process to complete. Because each Linux image is running in its own virtual system, the Linux images do not affect the other systems around them.

### **Server simplification inside System z**

Server simplification does not always have to happen outside your System z. Sometimes the best place is directly inside the mainframe, meaning taking other operating systems, such as z/OS, that are on other logical partitions (LPARs) and moving them to a single LPAR running z/VM. Several benefits are the ability to:

- ▶ Free up LPARs for more mission critical environments
- ▶ Rapidly bring up and down test and development environments
- ▶ Help reduce the cost of upgrades because you can free up LPARs and not have to buy another System z

z/VM enables you to have a spare system on which to try out an idea or to isolate a task. Because z/VM is capable of making available almost limitless spare systems in virtual machines, it allows your IT department to effectively use the whole power of their System z. An advantage of making one system look like many is that you can create an exact replica of your production system on which to test your new programs, services, and procedures. This is a relatively inexpensive way to have your own test system (or as many test systems as you would like). It is also a safe way to test a new function, because your real production system and its applications and data, are protected from any damage that the new function might cause if you tested it on the host system.

## 1.3.2 Ten great reasons to run Linux as a guest of z/VM

Running the Linux operating system as a guest of z/VM is a smart choice. Consider the following benefits<sup>1</sup> z/VM offers a Linux guest environment:

- ▶ Sharing resources  
Resources can be shared among multiple Linux images running on the same z/VM system. These resources include processor cycles, memory, storage devices, and network adapters.
- ▶ Server hardware consolidation  
Running tens or hundreds of Linux instances on a single System z server offers customers savings in space and personnel required to manage real hardware.
- ▶ Virtualization  
The virtual machine environment is highly flexible and adaptable. New Linux guests can be added to a z/VM system quickly and easily without requiring dedicated resources. This is useful for replicating servers in addition to giving users a highly flexible test environment. See 2.1.1, “Benefits of virtualization” on page 10 for more benefits.
- ▶ System z advantages  
Running Linux on z/VM means the Linux guest or guests can transparently take advantage of z/VM support for System z hardware architecture and RAS features.  
z/VM supports Integrated Facility for Linux (IFL) processors, which can be an attractively-priced hardware feature for Linux workloads running on System z.
- ▶ z/VM connectivity  
Using guest LANs and virtual switches (VSWITCH), z/VM provides high-performance communication among virtual machines running Linux and other operating systems on the same processor. The underlying technologies enabling high-speed TCP/IP connections are virtual channel-to-channel (CTC) adapter support and VM IUCV (Inter-User Communication Vehicle). Simplification of the network by using HiperSockets™ can provide savings and reduce cabling, hubs, switches, and routers. It can also help to reduce the maintenance effort.
- ▶ Minidisk driver  
Linux on System z includes a minidisk device driver that can access all DASD types supported by z/VM.

---

<sup>1</sup> <http://www.vm.ibm.com/linux/benefits.html>

- ▶ Data-in-memory  
Data-in-memory performance boosts are offered by VM exploitation of the z/Architecture®.
- ▶ Debugging  
VM offers a rich debug environment that is particularly valuable for diagnosing problems in the Linux kernel and device drivers.
- ▶ Control and automation  
z/VM's long-standing support for scheduling, automation, performance monitoring and reporting, and virtual machine management is available for Linux virtual machines.
- ▶ Horizontal growth  
An effective way to grow your Linux workload capacity is to add more Linux guests to a z/VM system.





## Introducing z/VM to z/OS system programmers

This chapter starts with a short discussion of the basics of virtualization. It continues with an overview of z/VM concepts and features. The chapter also provides lists of references for more details on the each subject.

As you become a z/VM system programmer or system administrator, you will have to understand the concept of virtualization and how z/VM implements virtualization.

### Objectives

After completing this chapter, you should be able to:

- ▶ Understand basic concepts of virtualization and how z/VM takes advantage of it
- ▶ Describe the two z/VM components: Control Program (CP) and the Conversational Monitor System (CMS)
- ▶ Use basic navigation skills and commands with z/VM

## 2.1 Overview of virtualization

Virtualization is the ability for a computer system to share physical resources, such as memory, storage, network adapters, and processors so that it can behave as though it were many different systems.

Today, the most common areas of virtualization are with servers, networks, and storage. Virtualization can also be applied to non-physical resources such as applications, middleware, and even virtual resources themselves, such as virtualizing a cluster of virtual servers.

### 2.1.1 Benefits of virtualization

The cost of administering IT systems is growing faster than the cost of new hardware for those systems because the complexity of those systems requires growing numbers of people to manage them. A primary concern of management is to contain cost while increasing revenue levels.

Implementing virtualization can be a critical first step in managing computing infrastructures by:

- ▶ Lowering the cost of existing infrastructure
- ▶ Reducing the complexity of adding resources to that infrastructure
- ▶ Building a heterogeneous infrastructure across multiple data centers, making those centers more responsive to business requirements

The benefits of virtualization vary, depending on the objectives and the specific virtualization technologies selected and on the existing IT infrastructure. Users realize many of the following benefits to some degree, even when using virtualization for simple server consolidation.

#### **Higher resource utilization**

Virtualization enables the dynamic sharing of physical resources and resource pools, resulting in higher resource use, especially for variable workloads where the average requirements are lower than for an entire dedicated resource.

#### **Lower management costs**

Virtualization can improve staff productivity by: reducing the number of physical resources that must be managed; hiding some of the resource complexity; simplifying common management tasks through automation, better information and centralization; and enabling workload management automation.

Virtualization also enables common tools to be used across multiple platforms.

## **Usage flexibility**

Virtualization enables resources to be deployed and reconfigured dynamically to meet changing business needs.

## **Improved security and guest isolation**

Virtualization enables separation and compartmentalization that is not available with simpler sharing mechanisms, but that provides controlled, secure access to data and devices. Each virtual machine can be completely isolated from the host machine and other virtual machines. If one virtual machine crashes, others are not affected.

Virtualization prevents data from leaking across virtual machines, and ensures that applications communicate only over configured network connections.

## **Higher availability**

Virtualization enables physical resources to be removed, upgraded, or changed without affecting users.

## **Increased scalability**

Resource partitioning and aggregation enable a virtual resource, depending on the product, to be much smaller or much larger than an individual physical resource. This means you can make scale adjustments without changes to the physical resource configuration.

## **Interoperability and investment protection**

Virtual resources can provide compatibility with interfaces and protocols that are unavailable in the underlying physical resources. This is increasingly important for supporting existing systems and ensuring backward compatibility as done by z/VM.

## **Improved provisioning**

Virtualization can enable resource allocation to a finer degree of granularity than individual physical units. Virtualized resources, because of their abstraction from hardware and operating system issues, are often capable of recovering much more rapidly after a crash than a physical resource.

## **Consolidation**

Virtualization enables multiple applications and operating systems to be supported in one physical system. It consolidates servers into virtual machines on either a scale-up or scale-out architecture, and also enables systems to treat computing resources as a uniform pool that can be allocated to virtual machines in a controlled manner.

## 2.1.2 How virtualization works

Virtualization deals with enabling basic systems management of multiple, often heterogeneous systems directly *out of the box*.

As Figure 2-1 shows, partitioning and virtualization involve a shift in thinking from physical to logical by treating IT resources as logical pools rather than as separate physical entities. This involves consolidating and pooling IT resources, and providing a *single system illusion* for both homogeneous and heterogeneous servers, storage, distributed systems, and networks.

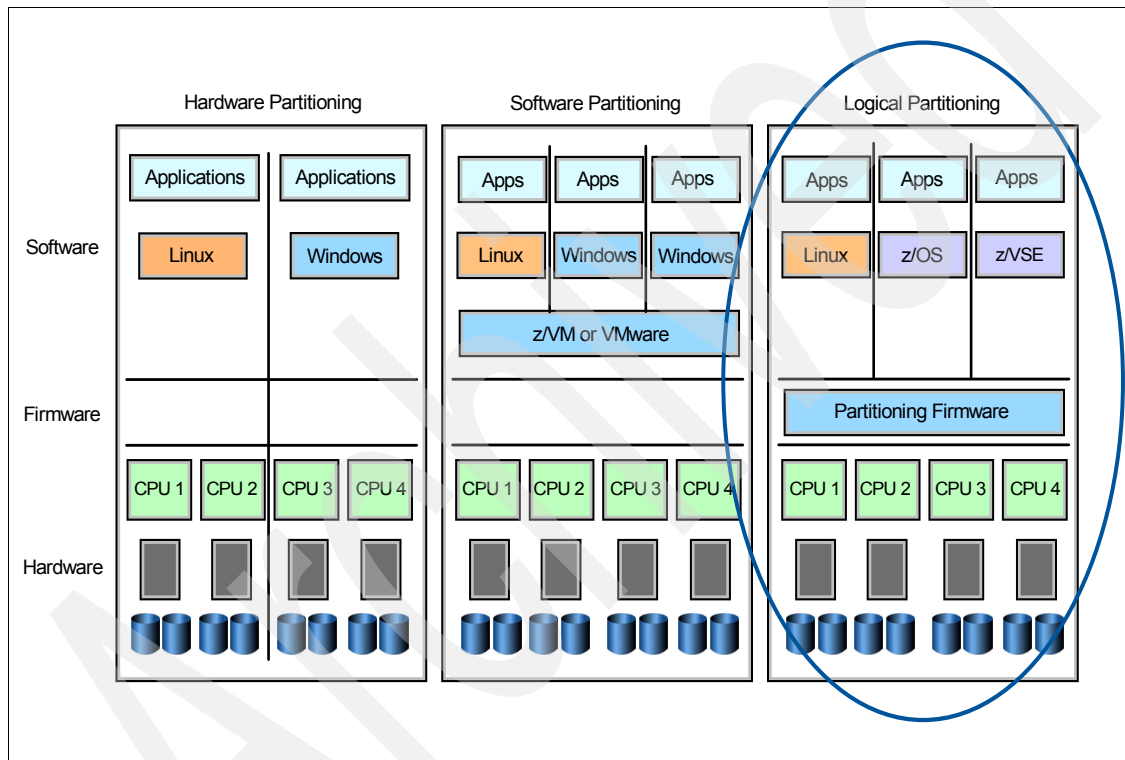

Figure 2-1 Logical partitioning<sup>1</sup>

Partitioning of hardware involves separate processors for separate operating systems, each of which runs its specific applications. Software partitioning employs a software-based hypervisor to enable individual operating systems to run on any or all of the processors.

<sup>1</sup> z/VM does not run Windows® as a *guest* operating system because Windows is not a mainframe operating system. Figure 2-1 shows the operating systems that run on z/VM or VMWare; it does not show the operating systems that run on both.

Hypervisors are virtualization platforms that allow multiple operating systems to run on a host computer at the same time. Hypervisor technology originated with the System 360, model 67, which evolved into the IBM VM/370, the predecessor of the z/VM. Creating a logical partition (LPAR) involves partitioning firmware (a hardware-based hypervisor) to isolate the operating system from the processors.

### 2.1.3 Virtualization on the mainframe

Typically, IBM mainframes can be partitioned in the following three ways:

- ▶ Basic mode: In this mode, also called *native mode*, the entire physical system is used as a single system. This mode, which can be selected during system activation, is the least used mode of operation. In basic mode, logical partitions (LPARs) are not supported.

**Note:** On z9® and z10 mainframes, basic mode is no longer supported so you must define at least one LPAR.

- ▶ LPAR mode: In this logically partitioned mode (LPAR mode) of operation, a single mainframe system is logically divided into multiple partitions. The LPAR mode, which can be selected during system activation, is the most common mode used on mainframes. Depending on the machine, the LPAR mode can provide additional facilities not available in basic mode, and these facilities can be exploited with operating system support.
- ▶ z/VM guest: IBM z/VM guest implementations are software level partitioning. The z/VM operating system runs either on an LPAR or, on older hardware, on the complete mainframe (basic mode). Then, virtual machines (VM) are created on top of the z/VM system to host other *guest* systems.

## 2.2 Overview of z/VM

Getting used to a new operating system (OS) usually involves getting to know the different ways of performing the same actions that you are familiar within another OS. However, sometimes an OS is so different from any other OS, that it is worth taking a look at a few basic concepts of the new OS before you actually start exploring its functions and capabilities.

At first glance, z/VM can look very different from other operating systems. However, after you learn about the basic concepts, navigating and exploiting the powers of this OS becomes easy. Powers of the z/VM lie in its ability to provide highly flexible test and production environments for enterprises to deploy their on-demand business solutions. z/VM exploits the IBM z/Architecture and helps

enterprises meet their growing demands for multi-user server solutions with a broad range of support for operating platforms such as Linux on System z, z/OS, z/OS.e, VSE/ESA™, z/VSE™, and more.

For more information, refer to the following Web site:

<http://www.vm.ibm.com/index.html>

In this section, we explain what z/VM is and the features and components available in Version 5 Release 3. These introductory topics will be useful to you throughout this book as you begin your experience in z/VM. For a more detailed introduction see the IBM Redbooks publication, *Introduction to the New Mainframe: z/VM Basics*, SG24-7316.

## 2.2.1 History of z/VM

In the early 1960s, a small group of university scientists were working on the idea of a time-sharing computer system. The system that was created ran on the IBM processor of that time and provided time sharing, but was used in a more batch-like processing environment.

The idea of the virtual machine started in the mid 1960s with the work on a Control Program (CP) that could partition real disks into minidisks and handle unit record input/output (I/O) devices for each virtual machine. During that time, a Conversational Monitor System (CMS) was being developed as a monitor system for file and program manipulation. Rather than integrating the two systems, each were split into their own components. CP would provide a separate computing environment at the machine level for each user. CMS would provide single user services that did not have to worry about allocating or sharing resources.

Because the virtual machine Control Program was required to simulate the computer systems of that day, each virtual machine would need all the components of a computer. Unique computer identity, a secure location, input and output devices, along with memory and storage would have to be available to each virtual machine. Queuing work (to the I/O devices) was done by spooling the input or output to the device. Input was prepared on card punch machines; holes were punched into cards. The cards were fed to a card reader that would sense the location of the punched holes and electronically store the information in the computer's memory. After the computations were completed, output would be sent to an output device, such as impact printers or basic consoles.

We continue to see the legacy of those devices today in our z/VM systems.

Because each virtual machine has its own equipment and each must have addressability, the same default device addresses and device types are assigned to each machine, as follows:

Address 0009 is a 3215 console

Address 000C is a 2540 reader

Address 000D is a 2540 punch

Address 000E is a 1403 printer

Along with the I/O devices, each machine must have central processors and memory to run programs and storage to save data. Processors (virtual CPUs), memory (virtual storage), and disks (minidisks) complete the components required for each virtual machine.

As we log on to a z/VM user ID (our unique machine identifier) and enter our password (our secure location), we are actually initiating the process of starting a computer system. We first make contact with the CP where we are given the required hardware to run our system. Next, as we bring up our system, such as CMS, Linux, z/OS, or another z/VM system, we do an initial program load (IPL) of a system that already resides on disk. We might spool input to our punch, reader, or spool output to our printer or console.

Over the years, IBM assumed this development effort. Work on VM continued as IBM announced newer processors such as system/360 and system/370, but was not seen as a system that customers would widely use. As the base system/370 operating system, MVS™ continued its development efforts. Because few processor prototypes were available, the realization was that VM provided a necessary processor simulation platform for the MVS developers. VM became a popular system among many customers who found the ease of programming and versatility of the system beneficial to their businesses.

By the 1980s, VM installations grew and more business processes and applications were being developed to run on VM. Customer popularity brought about enhanced programming products for VM such as REXX™ and Pipelines, which has since been ported to other operating systems. As new IBM processors and architectures were developed, VM kept pace with new functions to exploit the features.

With the advent of other technologies and systems, z/VM was becoming less of a front-end direct-user interface and more of an IBM virtualization technology platform. Now, with the popularity of Linux and the recognition of z/VM virtualization capabilities, it has again demonstrated its place in the System z operating system portfolio.

As with early computers, z/VM has evolved from its early roots and now provides many more functions and services, although the underlying principles of the virtual machine has not significantly changed.

Figure 2-2 shows a timeline of how z/VM has evolved to today's version.

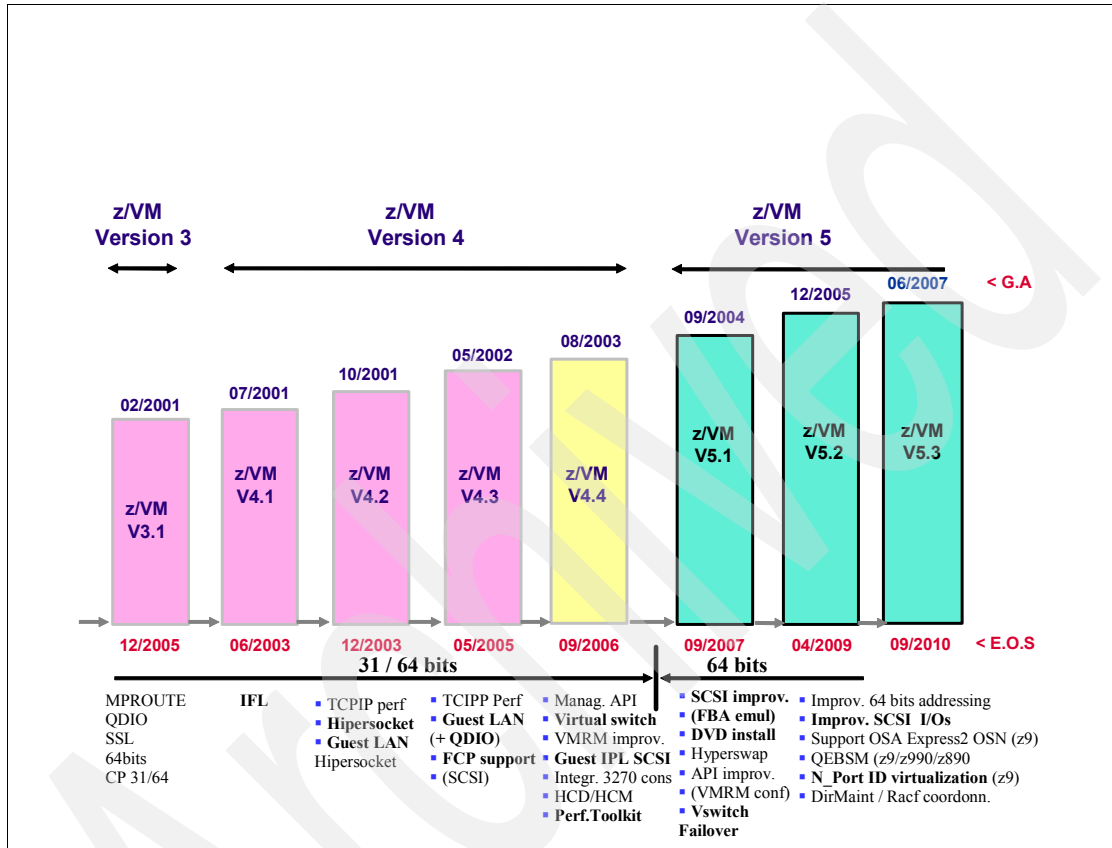

Figure 2-2 History of z/VM

## 2.2.2 About z/VM

z/VM provides each user with an individual working environment known as a *virtual machine*. The virtual machine simulates the existence of a dedicated real machine, including processor functions, memory, networking, and input/output (I/O) resources. Operating systems and application programs can run in virtual machines on the second level as guest. For example, you can run multiple Linux and z/OS images on the same z/VM system each on their own virtual machine.



As a result, development, testing, and production environments can run side by side sharing the same resources.

A virtual machine can use its own real hardware resources (for example, a tape drive); however, for the most part it shares from a pool of virtual hardware managed by z/VM. The virtual address of these devices might or might not be the same as the real address of the actual device. Therefore, a virtual machine only knows *virtual hardware* that exists or does not exist in the real world.

### 2.2.3 First-level versus second-level guest system

A first-level z/VM means that it is the base operating system that is installed directly on top of the real hardware. A second-level system is a user brought up in z/VM where an OS can be executed upon the first-level z/VM.

In other words, a first-level z/VM operating system sits directly on the hardware, but the guests of this first-level z/VM system are virtualized; see Figure 2-3 on page 18. By virtualizing the hardware from the first-level, we are able to create and use as many guests as needed with a small amount of actual real hardware.

Operating systems running in these virtual machines are often called *guests*. Other phrases you might encounter include:

- ▶ *Running first level*, which means running directly on the hardware (this is what a base z/VM does).
- ▶ *Running second level, running under z/VM, or running on (top of) z/VM*, which mean running as a guest on the second-level.

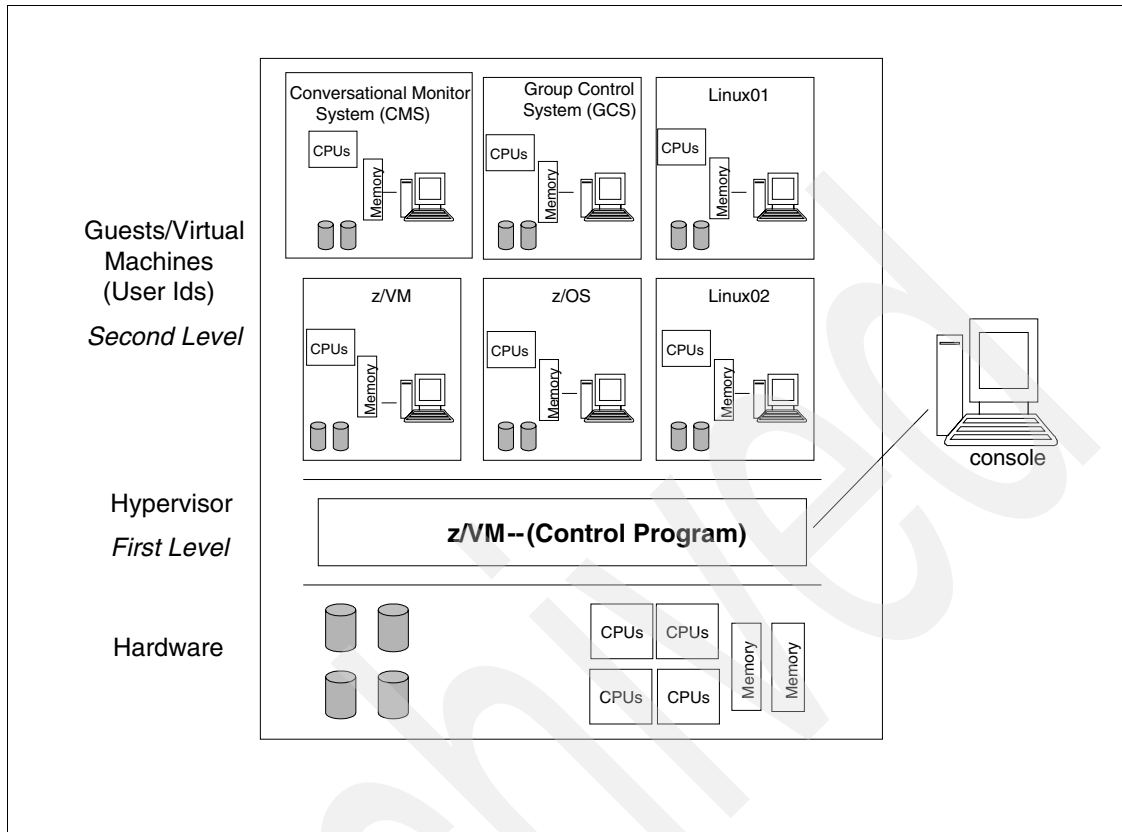

Figure 2-3 Example of configuration of an LPAR

## 2.2.4 User directory

The user directory (USER DIRECT) is a file containing all the information about all of the system's guests. It is usually owned by the MAINT user on disk 2CC.

**z/OS analogy:** The user directory can be seen as the equivalent of all user definitions in the security system, or contents of the SYS1.UADS data set.

When a user definition is created, we must specify the CP privilege classes, minimum and maximum virtual memory that a user can access, and the mode in which the VM will run (for example, ESA/XA) and the I/O devices it will need.

Example 2-1 on page 19 shows an entry for the user named IBMUSER1 in the user directory.

*Example 2-1 USER DIRECT entry for user IBMUSER1*

---

```
USER IBMUSER1 USER1PW 32M 128M G      1  
  INCLUDE IBMDFLT                      2  
  MACH XA                               3  
  IPL CMS                               4  
  MDISK 191 3390 1823 010 LX6RES MR    5
```

---

The entries in Example 2-1, in the z/VM guest definition in USER DIRECT, have the following meanings:

1. The USER line sets the user ID of this virtual machine, which is IBMUSER1. The password is USER1PW. This machine is defined as having a default memory storage of 32 MB when it logs in. This user could increase the memory allocation to a maximum of 128 MB by using the DEFINE STORAGE command. The last value represents the CP classes of a user ID (in our example, G is for general user authority).

**Note:** The DEFINE STORAGE command is disruptive; it can reset a guest operating system.

2. Include a default profile for common user attributes as shown in Example 2-2 on page 20.
3. Run this virtual machine in Extended Architecture (XA) mode.
4. At logon (initial program load), initialize Conversational Monitor System (CMS) automatically.
5. Establish a minidisk for the user. In our example, this establish the minidisk with virtual address 191 on a 3390 DASD volume at cylinder 1823 for 10 cylinders on DASD volume LX6RES with multi-write access.

If certain directory control statements are repeated for several users, you can make use of directory profiles to save space in the directory. Because you can potentially create many hundreds of Linux z/VM user IDs on a single z/VM image, you can create a profile to define the things that many user IDs have in common. The profile we included in our TCPIP user ID is shown in Example 2-2 on page 20.

```
PROFILE IBMDFLT
SPOOL 000C 2540 READER * 1
SPOOL 000D 2540 PUNCH A 1
SPOOL 000E 1403 A 1
CONSOLE 009 3215 T 1
LINK MAINT 0190 0190 RR 2
LINK MAINT 019D 019D RR 2
LINK MAINT 019E 019E RR 2
LINK MAINT 0402 0402 RR 2
LINK MAINT 0401 0401 RR 2
LINK MAINT 0405 0405 RR 2
```

---

The following statements, displayed in Example 2-2, are in the IBMDFLT profile:

1. The SPOOL statements define the user's virtual spool devices. The options you select modify operational functions associated with your virtual reader, printer, punch, or console.
2. Provide access to files that reside on other user's disks, in this case MAINT disks that contain CMS, tools and help files.

## 2.3 Components of z/VM

z/VM consists of the following components and facilities (*base products*):

- ▶ Control Program (CP)
- ▶ Conversational Monitor System (CMS)
- ▶ Transmission Control Protocol/Internet Protocol (TCP/IP) for z/VM
- ▶ Advanced Program-to-Program Communication/Virtual Machine (APPC/VM)
- ▶ Virtual Telecommunications Access Method (VTAM®) Support (AVS)
- ▶ Dump Viewing Facility
- ▶ Group Control System (GCS)
- ▶ Hardware Configuration Definition (HCD) and Hardware Configuration Manager (HCM) for z/VM
- ▶ Language Environment®
- ▶ Open Systems Adapter Support Facility (OSA/SF)
- ▶ Restructured Extended Executor/Virtual Machine (REXX/VM)
- ▶ Transparent Services Access Facility (TSAF)
- ▶ Virtual Machine Serviceability Enhancements Staged/Extended (VMSES/E)

In addition to the base products, z/VM offers the following *optional products*:

- ▶ Data Facility Storage Management Subsystem for VM (DFSMS/VM™)
- ▶ Directory Maintenance Facility for z/VM (DirMaint™)
- ▶ Performance Toolkit for VM
- ▶ RACF Security Server for z/VM
- ▶ Remote Spooling Communications Subsystem (RSCS) Networking for z/VM

In the following sections, we discuss each component and provide pointers to reference material where you can learn more about each topic.

### 2.3.1 Control Program

Control Program (CP) is primarily a real-machine resource manager. CP provides each user with an individual working environment known as a *virtual machine*. Each virtual machine is a functional equivalent of a real system, sharing the real processor function, storage, console, and input/output (I/O) device resources.

When you first log on to z/VM, CP controls the working environment. Many of the facilities of z/VM are immediately available to you. For example, you can use CP commands to do various system management tasks. However, most of the work done on z/VM requires the Conversational Monitor System (CMS). From this environment, a guest operating system (such as z/OS) can be loaded (IPL) and run within the user ID.

CP provides connectivity support that allows application programs to exchange information with each other and to access resources residing on the same z/VM system or on different z/VM systems.

CP is discussed further in section 2.4, “Control Program (CP)” on page 33.

**z/OS analogy:** CP is the equivalent of z/OS nucleus or supervisor.

### 2.3.2 Conversational Monitor System

Conversational Monitor System (CMS) is a single-user operating system (you interact with one user, one keyboard, and one monitor). CMS can help you perform a wide variety of tasks. For example, you can write, test, and debug application programs for use on CMS or a guest system’s base product, as listed in the following tasks:

- ▶ Run application programs developed on CMS or guest systems
- ▶ Create and edit data files

- ▶ Process jobs in batch mode
- ▶ Share data between CMS and guest systems
- ▶ Communicate with other system users
- ▶ Provide a useful file system for storing data

## CMS file system

The *file* is the essential unit of data in CMS. Files in CMS are unique and cannot be read or written using other operating systems. When you create a file in CMS, you name it by using a file identifier (file ID). The file ID consists of three fields:

- ▶ File name (fn): Contains a maximum of eight alphanumeric characters
- ▶ File type (ft): Contains a maximum of eight alphanumeric characters
- ▶ File mode (fm): Contains one alphabetic character

**z/OS analogy:** A CMS file is like a sequential data set on z/OS or a z/OS file on UNIX® System Services.

When you use CMS commands and programs to modify, update, or refer to files, you must identify the file by using the file ID fields. Various CMS commands allow you to enter only the file name, or the file name and file type; others require you to also enter the file mode.

Under z/VM, your files can be stored within a Shared File System (SFS), which is a shared file space in a hierarchical directory structure. Depending on your system configuration, you have the option to use both CMS and SFS methods for storing files. You could store files that you might want to share in your SFS file space; other files could be stored on minidisks.

z/VM OpenExtensions (POSIX support) includes another type of file called a byte file system (BFS) file. BFS files are organized in a hierarchy, as in a UNIX system. All files are members of a *directory*. Each directory is in turn a member of another directory at a higher level in the hierarchy. The highest level of the hierarchy is the BFS file space. Typically, a user has all or part of a BFS file space mounted as the root directory.

z/VM views an entire file hierarchy as a byte file system. Each byte file system is a mountable file system. The *root* file system is the first file system mounted. Subsequent file systems can be mounted on any directory within the root file system, or on a directory within any mounted file system.

All files in the byte file system are called BFS files. BFS files are byte-oriented, rather than record-oriented, such as CMS record files on minidisks or in the Shared File System. You may copy BFS files into CMS record files, and copy CMS record files into the byte file system.

CMS is discussed further in section 2.5, “Conversational Monitor System (CMS)” on page 35.

### 2.3.3 TCP/IP

TCP/IP for z/VM brings the power and resources of your mainframe server to the Internet. Using the TCP/IP protocol suite of TCP/IP for z/VM, you can reach multiple vendor networking environments from your z/VM system.

TCP/IP for z/VM allows z/VM systems to act as peers of other central computers in TCP/IP open networks. Applications can be shared transparently across z/VM, Linux, and other environments. Users can send messages, transfer files, share printers, and access remote resources with a broad range of systems from multiple vendors.

TCP/IP for z/VM provides the following types of functions and interfaces:

- ▶ Connectivity and gateway functions, which handle the physical interfaces and routing of data
- ▶ Server functions, which provide a service to a client (that is, send or transfer a file)
- ▶ Client functions, which request a particular service from a server anywhere in the network
- ▶ Network status and management functions, which detect and solve network problems
- ▶ Application programming interfaces, which allow you to write your own client/server application

**z/OS analogy:** TCP/IP for z/VM has the same functionality as in z/OS.

### 2.3.4 APPC/VM VTAM Support (AVS)

APPC/VM VTAM Support (AVS) is a Virtual Telecommunications Access Method (VTAM) application that provides Advanced Program-to-Program Communication (APPC) services between VM and non-VM systems in a Systems Network Architecture (SNA) network.

AVS and VTAM run in the same Group Control System (GCS) group on a z/VM system. Together, AVS and VTAM enable APPC/VM application programs in a

TSAF or communication services (CS) collection to communicate with the following applications:

- ▶ Other APPC/VM applications residing in other VM systems within the SNA network
- ▶ APPC applications residing in non-VM systems in the SNA network

**z/OS analogy:** This functions the same as in z/OS.

### 2.3.5 Dump Viewing Facility

The Dump Viewing Facility (DVF) helps you interactively diagnose system problems. Using this facility, you can display, format, and print data interactively from virtual machine dumps, and display and format recorded trace data.

The BLOCKDEF utility enables you to display, format, and print control block information. The VIEWSYM command lets you display symptom records, allowing you to more easily identify duplicate problems when they occur.

**z/OS analogy:** DVF is similar to the Interactive Problem Control System (IPCS) in z/OS.

### 2.3.6 Group Control System (GCS)

Group Control System (GCS) runs in an Extended Architecture (XA) or Extended Common (XC) mode virtual machine in place of CMS. It is a virtual machine supervisor, providing multitasking services that allow numerous tasks to remain active in the virtual machine at one time.

A function of GCS is to support a native SNA network. The SNA network relies on ACF/VTAM, VTAM SNA Console Support (VSCS), and other network applications to manage its collection of links between terminals, controllers, and processors. GCS provides services for ACF/VTAM, VSCS, and the others, which eliminates your need for VTAM Communications Network Application (VM/VCNA) and a second operating system such as VSE.

### 2.3.7 HCD and HCM for z/VM

Hardware Configuration Definition (HCD) and Hardware Configuration Manager (HCM) for z/VM provide a comprehensive I/O configuration management environment, similar to that available with the z/OS operating system.



HCM runs on a Windows-based personal computer connected to the z/VM system through a TCP/IP network connection. HCM provides a graphical user interface and commands to help you configure your system. You supply the required I/O configuration information to HCM, which processes the information and passes it to HCD.

HCD runs in a z/VM server virtual machine and performs the work of creating and changing the hardware and software aspects of your I/O configuration.

Although HCM provides the primary user interface to HCD, if HCM is not available, HCD also provides a backup user interface on your z/VM host for certain I/O configuration tasks.

The original dynamic I/O configuration capabilities of z/VM are still valid. These consist of a set of system operator commands for changing the hardware server's I/O configuration while the system continues to run, or for managing the hardware I/O configuration of all logical partitions in your server.

You have the choice of using either these commands or the HCM and HCD to manage your I/O configuration. Note, however, that the use of HCM and HCD is incompatible with the original dynamic I/O configuration capabilities. You should select one method to use for the duration of any given IPL of your z/VM system.

**z/OS analogy:** HCD and HCM for z/VM function the same as in z/OS.

## 2.3.8 Language Environment

Language Environment provides the runtime environment for programs written in C/C++, COBOL, or PL/I languages. Language Environment helps you create mixed-language applications and gives you a consistent method of accessing common, frequently-used services.

Language Environment consists of the following features:

- ▶ Basic routines that support starting and stopping programs, allocating storage, communicating with programs written in different languages, and indicating and handling conditions.
- ▶ Common library services, such as math services and date and time services, that are commonly needed by programs running on the system. These functions are supported through a library of callable services.
- ▶ Language-specific portions of the runtime library are consistent. Because many language-specific routines call Language Environment services, behavior is consistent across languages.

**z/OS analogy:** Language Environment functions the same as in z/OS.

### 2.3.9 OSA/SF

The Open Systems Adapter-Express (OSA-Express) and Open Systems Adapter Express2 (OSA-Express2) are integrated hardware features that allow the System z platform to provide industry-standard connectivity directly to clients on local area networks (LANs) and wide area networks (WANs).

The Open Systems Adapter Support Facility (OSA/SF) is a host-based tool supplied with z/VM that allows you to customize an OSA's modes of operation. You can access OSA/SF by a CMS user ID, by a REXX call to the OSA/SF API, or through a Java™-based graphical user interface (GUI).

**z/OS analogy:** OSA/SF has the same functionality as in z/OS.

### 2.3.10 REXX/VM

REXX/VM contains the REXX/VM Interpreter, which processes the English-like Restructured Extended Executor (REXX) programming language. It also contains the z/VM implementation of the SAA® REXX programming language. REXX/VM provides a single source base for the REXX/VM Interpreter in the CMS and GCS components. The REXX/VM Interpreter exploits 31-bit addressing.

The REXX/VM Interpreter helps improve the productivity of your organization. Using REXX, you can write customized application programs and command procedures, tailor CMS commands, and create new XEDIT macros.

**z/OS analogy:** Minor differences exist between REXX/VM and REXX in z/OS. For instance, the default REXX environment on z/VM would be CMS and in z/OS it would be TSO.

### 2.3.11 TSAF

Transparent Services Access Facility (TSAF) provides communication services within a collection of VM systems without using VTAM. TSAF runs in a CMS virtual machine.

A group of up to eight VM systems that each have TSAF installed and running can form a TSAF collection. APPC/VM programs on one VM system in the TSAF collection can communicate with other APPC/VM programs on the other VM systems in the collection. The routing is transparent to the application programs. Communications between the applications proceed as though the applications were running on the same system.

### 2.3.12 VMSES/E

Virtual Machine Serviceability Enhancements Staged/Extended (VMSES/E) helps you install z/VM and other VMSES/E-enabled products and apply code changes that correct or circumvent reported problems. VMSES/E handles both source code and object code.

VMSES/E can also help you define, build, and manage saved segments. The VMFSGMAP command provides a saved segment mapping interface that lets you modify saved segment definitions and view saved segment layouts prior to actually building them on your system.

**z/OS analogy:** VMSES/E is similar in concept to SMP/E

The next sections provide overviews of the optional features of z/VM.

### 2.3.13 DFSMS/VM

Data Facility Storage Management Subsystem for VM (DFSMS/VM) allows you to control your data and storage resources more efficiently.

**z/OS analogy:** DFSMS/VM has similar functionality to z/OS DFSMS™

DFSMS/VM provides support for space management, minidisk management, ISMF, and IBM tape library dataservers. These are described in the following sections.

#### **Space management**

DFSMS/VM improves DASD use by automatically managing space in SFS file pools. As the SFS administrator, DFSMS/VM allows you to:

- ▶ Convert SFS storage to DFSMS-managed storage by assigning management classes to files and directories. Each management class tells DFSMS/VM how to treat its members in the course of its management of the file pool.

- ▶ Automatically manage files based on the criteria in each management class. This management can consist of deletion of files, automatic migration of files, or both.
- ▶ Migrate (or move) files from DFSMS-managed storage to DFSMS-owned storage by using the assigned management class. This function also compresses the data. The files can be automatically recalled when referenced (opened and browsed), or they can be explicitly recalled.

### **Minidisk management**

Using DFSMS/VM for minidisk management allows you to check the integrity of CMS minidisks and move them from one location to another. DFSMS/VM helps you migrate CMS minidisks to new DASD quickly, efficiently, and with minimal effect to users.

### **Interactive Storage Management Facility (ISMF)**

DFSMS/VM uses the Interactive Storage Management Facility (ISMF) to provide a consistent user interface for storage management tasks.

### **IBM Tape Library Dataserver support**

DFSMS/VM provides native VM support for the IBM 3494 and 3495 Tape Library Dataservers.

## **2.3.14 Directory Maintenance Facility for z/VM**

The Directory Maintenance Facility (DirMaint) for z/VM provides efficient and secure interactive facilities for maintaining your z/VM system directory. Directory management is simplified by DirMaint's command interface and automated facilities. DirMaint provides a corresponding command for every z/VM directory statement, including cross system extensions (CSE) cluster directory statements. DirMaint's error checking ensures that only valid changes are made to the directory, and that only authorized personnel are able to make the requested changes.

DirMaint offers the following functionality:

- ▶ DirMaint operates as a CMS application and uses CMS interfaces for CMS and CP services. As a CMS application, DirMaint does not depend on specific hardware, although it does verify that the device types specified in DirMaint commands are only those supported by the z/VM host.
- ▶ DirMaint functions are accomplished by two disconnected virtual machines equipped with an automatic restart facility. The use of virtual machines takes

advantage of the inherent reliability, availability, and serviceability of the system architecture.

- ▶ DirMaint allows any transaction requiring the allocation or deallocation of minidisk extents to be handled automatically.
- ▶ DirMaint allows all user-initiated transactions to be password-controlled and recorded for auditing purposes.
- ▶ Command authorization is controlled by assigning DirMaint commands to privileged command sets. Users may be authorized to issue commands from multiple command sets. DirMaint provides nine predefined command sets, but up to 36 sets are supported.
- ▶ User exit routines enable centralized directory maintenance of remote systems. Some exit routines also enable DirMaint to interact with other facilities, such as RACF.
- ▶ The open command structure allows you to replace all commands with your own user-written commands.
- ▶ An automated process for copying CMS minidisk files minimizes the possibility of human error. This process optionally formats the old (source) minidisk before returning it to the available minidisk pool.
- ▶ The integrity of CMS files is ensured by preventing new minidisk space from being inadvertently allocated over existing extents.
- ▶ DirMaint improves overall system efficiency by minimizing the number of DIRECTXA utility runs required. The update-in-place facility (DIAGNOSE code X'84') can be used to place many of the changes online immediately.
- ▶ System security is enhanced by providing the ability to enforce regular password changes. When changing the password, the user is required to enter the new password twice to guard against typographical errors.
- ▶ DirMaint allows an additional level of security to be implemented by requiring that a password be entered for every user transaction. This is the default.

### 2.3.15 Performance Toolkit for VM

The Performance Toolkit for VM™, which is derived from the FCON/ESA program (5788-LGA), assists operators and systems programmers or analysts in the following areas:

- ▶ Operation of the system operator console in full-screen mode
- ▶ Support for managing multiple VM systems
- ▶ Post-processing of VM history files
- ▶ Performance monitoring
- ▶ Serving data through a Web server for viewing with Web browsers

- ▶ Personal computer-based graphics
- ▶ TCP/IP performance reporting

In addition to analyzing VM performance data, the Performance Toolkit processes Linux performance data obtained from the Resource Management Facility (RMF™) Linux modular data gatherer, `rmfpms`. The gathered data can be analyzed using the RMF PM client application. The Linux performance data obtained from RMF can be viewed and printed in a manner similar to the presentation of VM data.

The `rmfpms` application is available from the following site:

<http://www.ibm.com/servers/eserver/zseries/zos/rmf/rmfhtmls/pmweb/pmlin.html>

**z/OS analogy:** The application is similar to RMF MONITOR in z/OS.

### 2.3.16 RACF Security Server for z/VM

The Resource Access Control Facility (RACF) Security Server for z/VM is a security tool that works together with existing functions in the z/VM base system to provide improved data security for an installation. RACF protects information by controlling access to it.

RACF also controls what you can do on the operating system and protects your resources. It provides this security by identifying and verifying users, authorizing users to access protected resources, and recording and reporting access attempts.

To help each installation meet its unique security requirements and objectives, RACF provides:

- ▶ Flexible control of access to protected resources
- ▶ Ability to store information for other products
- ▶ Choice of centralized or decentralized control profiles
- ▶ Transparency to users
- ▶ Exits for installation-written routines

Your organization can define individuals and groups who use the system that RACF protects. A security administrator uses RACF to define a profile for each individual that identifies that person's user ID, password, and other information.

A *group* is a collection of individuals who have common needs and requirements. For example, a whole department might be defined as one group. Your organization can also define what authorities you have, or what authorities a group you belong to has. RACF controls what you can do on the system. Certain

individuals have a high degree of authority, while others have little authority. The degree of authority you are given is based on what your job involves.

In addition to defining user and group authorities, RACF protects resources. You can protect system resources and user resources. System resources include system minidisks, system SFS files and directories, certain VM events, and terminals. User resources include user minidisks, and user SFS files and directories.

RACF stores all information about users, groups, and resources in profiles. A *profile* is a record of RACF information that has been defined by the security administrator. Profiles can be user, group, and resource profiles.

Using the information in its profiles, RACF authorizes access to specific resources. RACF applies user attributes, group authorities, and resource authorities to control use of the system. The security administrator, or someone in authority in your organization, controls the information in your user profile, in group profiles, and in resource profiles. You, as a user, control the information in profiles describing your own resources, such as your own minidisks. You can protect your data by setting up resource profiles. You can set up an access list in your resource profile to control who has read-access and who has write-access to your data.

In addition to uniquely identifying and authorizing users, RACF can record what users do on the system. It keeps track of what happens on the system so that an organization can monitor who is logged on to the system at any given time. RACF reports if persons have attempted to perform unauthorized actions. For example, RACF can record when someone who does not have the proper authority tries to use or change your data. The security administrator can monitor these activities and generate reports.

**z/OS analogy:** RACF for z/VM has the same functionality as RACF for z/OS.

### 2.3.17 RSCS Networking for z/VM

RSCS Networking for z/VM, or Remote Spooling Communication Subsystem, commonly referred to as RSCS, is a networking program that enables users on a z/VM system to send messages, files, commands, and jobs to other users within a network. RSCS connects nodes (systems, devices, and workstations) by using links, which allow data to be transferred between the nodes.

Running under the GCS component of z/VM, RSCS uses the spooling facilities of z/VM to store and retrieve data. z/VM handles data transfer within its system by means of spooling. RSCS extends the basic spooling capabilities of z/VM,

handling data transfer between the z/VM system and outside sources. Data is stored on a spool after RSCS receives it and until RSCS can forward it to its destination. RSCS uses communications equipment to transfer data between the local z/VM system and other systems or remote locations.

A node in an RSCS network is either a system node or a station node. A station node, which can originate and receive information, can be a computer, a workstation, or a printer. A system node, however, must be a computer. In addition to originating and receiving information, system nodes can also relay information between two other nodes.

RSCS can communicate with system nodes that are running under the control of network job entry (NJE)-compatible subsystems, which might require licensing, such as:

- ▶ JES2 or JES3
- ▶ RSCS
- ▶ VSE/POWER
- ▶ AS/400® Communications Utilities
- ▶ Products that provide NJE functions for Linux or AIX®

RSCS can communicate with the following types of station nodes:

- ▶ ASCII printers or plotters
- ▶ Computers running under the control of a system that can provide a multileaving protocol
- ▶ IBM 3270 Information Display System Printers
- ▶ Line printer router (LPR) daemons and clients in a TCP/IP network
- ▶ Unsolicited File Transfer (UFT) daemons and clients in a TCP/IP network
- ▶ Workstations running under the control of remote job entry (RJE)

Each link in an RSCS network is associated with a programming routine, called a *driver*, that manages the transmission and reception of files, messages, and commands over the link. The way that a driver manages the data is called a *protocol*. All file transmission between networking nodes uses NJE protocol, 3270 printers use 3270 data streams, workstations use RJE protocol, and ASCII printers use data streams appropriate to that printer.

Systems Network Architecture (SNA) provides one set of protocols that governs communications on links. The method that RSCS uses for sending data to a node varies, depending on the type of connection used to establish the link. RSCS can support non-SNA (such as binary synchronous communication or channel-to-channel), SNA, and TCP/IP connections.

**z/OS analogy:** RSCS networking is similar to JES2 networking in z/OS.



## 2.4 Control Program (CP)

The two primary components of z/VM are the Control Program (CP) and the Conversational Monitor System (CMS). The other z/VM components are discussed later in this chapter. In this section, we explain the functions and concepts of CP. We also discuss the modes of execution.

### 2.4.1 CP functions and concepts

CP is the operating system that underlies all of z/VM. CP is responsible for virtualizing your System z machine's real hardware and allowing all the virtual machines to simultaneously share that real hardware resource.

CP also handles the creation and management of virtual machines. It can be considered the operating system component of z/VM because it is responsible for managing real devices and resources and sharing them among various tasks and users that need them.

**z/OS analogy:** CP is analogous to the NUCLEUS or SUPERVISOR in z/OS or the kernel in a Linux operating system.

As a resource manager, CP can provide you with a set of virtual machines, which can run any operating system that would not ordinarily run on your System z hardware. Without CP you could be running only one operating system on your hardware at any given time (logical partitioning aside). CP allows you to have multiple virtual machines (also known as *guests*), and each one can be running an instance of an operating system simultaneously. As shown in Figure 2-4 on page 34, CP allows you to run many Linux and z/OS images simultaneously on the same piece of hardware.

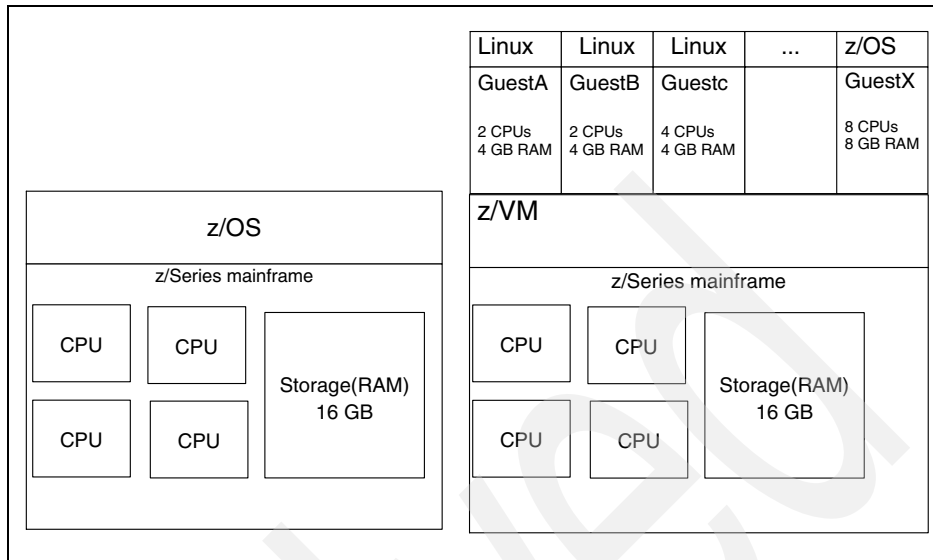

Figure 2-4 CP executing many guest operating systems

Notice in the figure that, even though we only have 4 CPUs and 16 GB of real storage, our guest virtual machines are collectively defined to have 16 CPUs and 20 GB of storage. This is because the CPUs and storage in a guest's operating system are virtual. You can create a guest that has 64 CPUs if you prefer; CP will take turns executing tasks on behalf of all 64 virtual CPUs on all of the available real processors. The CP components that handle this task are known as the *scheduler* and the *dispatcher*.

**z/OS analogy:** These components are very much like the process scheduler and dispatcher of z/OS or the scheduler of Microsoft® Windows and GNU/Linux, except they schedule entire virtual machines for execution instead of simply processes.

Note that the ability to overcommit resources like this only works because an operating system typically does not need 100% of the resources allocated to it all the time that it is running. Sometimes that operating system might be idle, and when it is, another operating system can use the hardware resources.

Virtual machines are defined in a text file known as the user directory as discussed in 2.2.4, "User directory" on page 18. For each virtual machine on the system, a section in the directory describes that virtual machine. One of these descriptions is known as a *directory entry*.

The directory entry for a guest details its guest name, its privileges to execute CP commands, the number of CPUs it has, the amount of memory it has, and information about which virtual devices are defined for this particular VM. It is the job of the system administrator to set up and maintain the user directory; general users typically do not have access to it.

## 2.4.2 CP modes of execution

At any time, your virtual machine is in one of two basic states of execution:

- ▶ Running a guest operating system (guest mode or emulation mode)
- ▶ Not running a guest operating system (CP mode)

When a guest operating system is running, it is controlling the devices and resources of your virtual machine. Any commands you issue to the virtual machine through your terminal command line are likely interpreted by the guest operating system and not CP.

However, when your virtual machine is *not* running a guest operating system, CP has control, and your processors and other virtual devices are generally sitting idle, not consuming real machine resources. In this state, any command issued to the virtual machine through your terminal command line are interpreted by CP and not a guest operating system.

Before you start a guest operating system, you are in CP mode. When you start a guest operating system, you are in guest mode. If you shut down your guest operating system, you are returned to CP mode. Your virtual machine can only be in one of these modes at any instance in time.

You may, however, switch between these modes any time, even when your guest operating system is running. If you switch to CP mode while a guest operating system is running, that operating system becomes frozen and will not run again until you leave CP mode and return to guest mode. At that time, the guest operating system continues running as though it had never been interrupted.

## 2.5 Conversational Monitor System (CMS)

The Conversational Monitor System (CMS) is the most commonly used point of interaction with z/VM. CMS exposes the vast power of the mainframe through a rich set of commands and utilities that build on the toolset CP provides. It is an operating system designed to facilitate mainframe virtual machine administration by providing users an environment with a higher functional level than CP. The

CMS executes on top of CP just as any other another operating system that can run on CP.

**z/OS analogy:** CMS is similar to TSO in z/OS and user space in LINUX.

CMS can help you perform a variety of tasks such as: writing, testing, and debugging application programs for use on CMS or guest systems; executing application programs developed on CMS or guest systems; creating and editing data files; sharing data between CMS and guest operating systems; and communicating with other system users.

**Note:** CMS is a powerful operating environment, but be aware that CMS *cannot* run at the same time as another guest operating system—only CP can do that.

## 2.5.1 Overview of the HELP command in CMS

This section and the following sections explain the use of the Help system (the HELP command (**he1p**)) in CMS. They describe task, component, and command menus, and discuss formatting options, such as selecting a layer (level). The sections list other ways to invoke the Help system, how to handle messages, and how to exit the Help system in CMS.

The useful **he1p** command in CMS command provides information about many standard system tasks. It also provides the syntax and function of all CMS and CP commands, and the meaning of error messages that can be reported to users.

Use the **he1p** command if you cannot remember the format of a command, or if you are looking for information about what a command does. The output displays the same information that is contained in the IBM documentation.

The easy-to-use **he1p** command is similar to the **man** command on Linux systems. If you type **he1p** by itself, a list of options and their descriptions are displayed.

The next several sections of this chapter explain how to access the **he1p** command more directly. To select an entry from the menu, place your cursor on the appropriate word and press Enter. Another help window opens, such as a task menu or a command menu.

**z/OS analogy:** The **he1p** command is similar to TSO HELP or to the HELP panels in ISPF.

## Task menus

Task menus are the portion of the Help system that provide an index and description of tasks that you can perform, including creating, modifying or changing files, or customizing the CMS installation. Task menus offer details about specific actions, without requiring you to know the name of the command in advance.

When you navigate to (drill down to) the bottom level of a particular topic, you find a description and correct format of the command.

To view the list of tasks and components available to you, type the following command, which is not case-sensitive:

```
help task
```

Figure 2-5 shows the output of a **help task** command.

```
HELP TASK                Task Help Information                line 1 of 39
(c) Copyright IBM Corporation 1990, 2004

z/VM Help, main panel

This panel lists other Help panels that provide information about
various z/VM functions, topics, and tasks.
To view a Help panel, move the cursor to any character of the name
and press the ENTER key or the PF1 key.

HELPINFO - HELP Facility topics
MENUS    - z/VM Help menus
TASKS    - Basic z/VM tasks - good choice for beginners
COMMANDS - z/VM commands available to general users
CMS      - CMS commands
CP       - CP commands
QUERYSET - QUERY and SET commands and subcommands
TCPIP    - TCP/IP commands
PF1= Help   2= Top   3= Quit   4= Return   5= Clocate   6= ?
PF7= Backward 8= Forward 9= PFkeys 10=       11=         12= Cursor

====> _

Macro-read 1 File
a 23/007
```

Figure 2-5 Output of help task command

## Component menus

The component menus list names of all the command HELP files available for a specific HELP component.

To display all the command HELP files available for CMS, start at the Task Help Information window (HELP TASK menu) shown in Figure 2-5 on page 37. Position your cursor anywhere under the word CMS and press Enter.

The Menu Help Information window is displayed as shown in Figure 2-6. The window displays all the command HELP files available for CMS.

```

CMS MENU                               Menu Help Information                line 1 of 42
(c) Copyright IBM Corporation 1990, 2004

Help for CMS commands

To view a Help panel, move the cursor to any character of the name
and press the ENTER key or the PF1 key.
An asterisk (*) preceding the name indicates a MENU panel.
A colon (:) preceding the name indicates a TASK panel.

*BORDER  CMDCALL  DSERV    GLOBALV  NETLCNVT  RT        SYNMSGs
*CMSQUERY CMSBATCH Edit    GRant    NOTE      RTNDrop   SYNonym
*CMSSET   COMpare  ERASE    HB        NUCXDROP  RTNLoad   SYSWATCH
*CMSUTIL  CONWAIT   ESERV    Help     NUCXLOAD  RTNMap    TAPE
*EDIT     COPYfile  ESTATE  HELPCONV NUCXMAP   RTNState  TAPEMAC
*FILESERV CP        ESTATEW  HI       OPNMSGs   RUN       TAPPDS
*OPENVM   CREate   ETRACE  HO       Option    SADT      TE
*OSHELL   CSLGEN   EXec    HT       OSRUN     SAMGEN    TELL

PF1= Help    2= Top      3= Quit    4= Return  5= Clocate  6= ?
PF7= Backward 8= Forward  9= PFkeys  10=       11=         12= Cursor

====> _

Macro-read 2 Files
a                                     23/007

```

Figure 2-6 CMS component menu

## Command menus

In addition to the task menus provided in the Help system, separate command menus for several VM components are available, including a menu for CP and CMS information. For example, if you select the command menu for CMS from the initial help menu, a panel showing a list of available CMS commands appears.

Menu navigation is similar to the task menus; to choose a command, place the cursor on it and press Enter or click PF1.

## 2.5.2 Layers (levels) of help

The Help system provides various ways of getting information for a command, depending on your level of expertise and the amount of detail you want for a particular task. Each command can display a brief, detailed, or related level of help.

To display any of the three available layers, specify one of the following layering options: BRIEF, DETAIL, or RELATED. You may specify only one layering option at a time. However, after you have requested one layer of help on a specified command, you may toggle (switch) between the other layers available for that command.

BRIEF is the default option, which means that if you do not specify an option, a brief layer of help is displayed, if it is available. If brief help is not available for a certain command, DETAIL HELP is displayed. The following sections provide more information about the three layers of command help.

### **BRIEF**

BRIEF is the first layer of help. It is available for many commands. Brief help displays a short description of the requested command, the command's basic syntax (the command without options), an example, and if applicable, a message telling you that either more or related information is available.

If you are in full-screen CMS and request BRIEF HELP, your window shows the help command you entered and just below it, displays the BRIEF HELP information in a window that is displayed on your window. If you are not in full-screen CMS, the Brief Help Information window is displayed.

The following example requests brief help for the SENDFILE command:

```
help cms sendfile (brief
```

If you are not in full-screen CMS, the output of this command is displayed in the Brief Help Information window as shown in Figure 2-7 on page 40.

```

CMS SENDFILE                Brief Help Information                line 1 of 14

SENDFILE

Brief Information

The SENDFILE command lets you send files to other users. An
abbreviation for SENDFILE is SF.

FORMAT:  SENDFile filename filetype userid (options

EXAMPLE: Greg needs a copy of your file SPEC SCRIPT A. His user ID is
Greg. To send him a copy, enter:
          sf spec script greg

PF1= All      2= Top      3= Quit      4= Return      5= Clocate    6= ?
PF7= Backward 8= Forward  9= PFkeys 10=          11= Related   12= Cursor
DMSHEL241I Press PF11 to get related information.
====> _
                                                    Macro-read 1 File
a                                                    23/007

```

Figure 2-7 Output of the request for brief help on the sendfile command

## DETAIL

The **DETAIL** layer provides a complete description of the command, the command format, an explanation of its parameters and options, usage notes, and error information. For more information regarding **DETAIL** help, refer to *z/VM: CMS Commands and Utilities Reference, SC24-6073*.

This layer of help has seven subsetting options: **DESCRIPT**, **FORMAT**, **PARMS**, **OPTIONS**, **NOTES**, **ERRORS**, and **ALL**. By specifying subsetting options, you can display one or more particular sections of the detail help.

The default option is **ALL**, which means that the entire detail help is displayed. Although changing the default option is possible, you will have to explicitly specify **ALL** as the subsetting option to display the entire detail layer. For more information about the subsetting options and the **DETAIL** command, refer to *z/VM: CMS Commands and Utilities Reference, SC24-6073*.

For example, to display all details of the **SENDFILE** command in the CMS environment, enter the following command:

```
help cms sendfile (detail)
```

Figure 2-8 shows the output of the command in the All Help Information window.



```

CMS SENDFILE                All Help Information                line 1 of 807
(c) Copyright IBM Corporation 1990, 2004

SENDFILE

>>--.-SENDfile-.-.-! Choice A !-.------>>
'-Sfile-----'  !-! Choice B !-!
                '-! Choice C !-'

Choice A:
  (1)
  .-(-----)
!-----!
!  (2)  !
!-----! Options !-----!
  (-)

Choice B:
  .-*--.
PF1= Brief    2= Top      3= Quit    4= Return    5= Clocate    6= ?
PF7= Backward 8= Forward  9= PFkeys 10=         11= Related   12= Cursor

====> _

Macro-read 1 File

```

Figure 2-8 Output of the command `help cms sendfile` (detail)

## RELATED

The help information entries for some commands allow you to select help entries for similar commands; this is known as *related* help.

For example, suppose you want to remove a file from your rdlst. After reading `HELP ERASE`, you realize that `ERASE` is not the correct command. Instead, using the `RELATED` layer of the `ERASE` command lets you easily access the help file for the correct command, `DISCARD`.

When you request related help on the `SET` or `QUERY` commands, the window lists and briefly describes all the `SET` and `QUERY` operands available for the system component. You can directly access help information about any of the displayed operands from these menu windows by positioning the cursor on a particular operand and pressing `Enter`.

The following example requests related help for the `ERASE` command in the CMS environment:

```
help cms erase (related
```

Figure 2-9 displays the output of the command.

```

CMS ERASE                               Related Help Information          line 1 of 20
Related Information

For RELATED information on removing files or parts of files from
your virtual machine, place the cursor under the topic of your choice
and press ENTER or the PF1 key.

DELETE  - Removes one or more lines from
         a file while using XEDIT.

ERASE   - Removes files from your minidisk
         or SFS directory.

PURGE   - Removes spool files from your
         reader, printer, or punch.

DISCARD - Removes files from "list-type"
         CMS command environments, such
PF1= Help   2= Top   3= Quit   4= Return   5= Clocate   6= ?
PF7= Backward 8= Forward 9= PFkeys 10= Morehelp 11= Brief   12= Cursor

====> _
                                                Macro-read 1 File
-----
VR a
23/007

```

Figure 2-9 Output of help cms erase (related)

### 2.5.3 Other help options

Five other options affect the help display: SCREEN, NOSCREEN, TYPE, NOTYPE, and EXTEND. These options control the display of files and error messages and the search order of commands. For complete descriptions of these options, refer to *z/VM: CMS Commands and Utilities Reference*, SC24-6073.

### 2.5.4 Other ways to get help

You can also get help for a specific command directly, without going through the various forms of help navigation we discussed. If you know the command you want help for, or want to navigate directly to it, specify the command type as:

- Help CP MENU            Displays the full menu of available CP commands.
- Help CP *command*     Displays the format of the specified CP command.

## 2.5.5 Getting help for error messages

When you perform a z/VM task and the system responds with a message, you can use HELP for messages to determine why the message was produced, and perform any necessary corrective action.

The HELP files for messages display the message text, an explanation of why the message was displayed, the system action, and a user action. For example, suppose you receive the following error message:

```
DMSERD107S Disk 'A'(191) is full
```

You wonder whether this message is significant, so you want more detailed information. For this particular error indicator, issue the `help` command, followed by the initial identifier present in the message `DMSERD107S`, as shown in the following two examples:

```
HELP DMSE107S
HELP DMS107S
```

**Note:** The module identifier (characters 4 to 6 of the message identifier) is ignored by HELP, so you do not have to enter it.

For example, to display information about message `DMSHLP002E`, you can enter any of these commands (not case-sensitive):

```
help msg dmshlp002e
help msg dms002e
help dmshlp002e
help dms002e
```

If you receive a message without a message ID, it could be because you have issued the `CP SET MSG TEXT` command to display only message text (or an application program might have issued the command).

To obtain information about a message with no message ID, you will have to use help facilities beyond the scope of those built in to CMS (such as the PDF or BookManager® version of the appropriate messages book).

## 2.5.6 Tips for using the Help system

Some commands might not work as expected in HELP mode. For this reason, we recommend that you do *not* enter commands on the command portion of the HELP window where they are displayed.

In general, use the HELP Menu only for help, and not as a command prompt.

## 2.5.7 Exiting the Help system

To exit the Help system in CMS at any time, use PF3 or type `quit` on the command line. These both take you back to the prior view. Note that you might have to issue the `quit` command multiple times if you have descended into the Help menu hierarchy and want to back out one level at a time.

As an alternative, you can use PF4 to completely leave the Help system with one key stroke.

**z/OS analogy:** Navigating the HELP menu in z/VM is similar to navigating the ISPF HELP menu in z/OS.

## 2.6 Networking options in z/VM

The System z brand offers many solutions to improve your network connectivity. Some of the key aspects about networking are the features implemented on System z and z/VM, which are OSA adapters, HiperSocket, and VSWITCH.

### 2.6.1 OSA adapters

The Open Systems Adapter (OSA) is a network controller that you can install in a mainframe I/O cage. The adapter integrates several hardware features and supports many networking transport protocols, including fast Ethernet, gigabit Ethernet, 10 gigabit Ethernet, Asynchronous Transfer Mode (ATM), and token ring.

Several versions of the OSA are available: OSA-Express, OSA-Express2, and OSA-Express3. The features of each are slightly different. The older OSA-2 cards have been superseded by the newer OSA-Express and OSA-Express2 cards and are no longer available, but many older mainframes still use them.

Network connectivity for the z/VM system or any of its guest operating systems could be provided by directly dedicating specific OSA addresses to the system. This can be done by the DEDICATE statement in the user directory or by attaching the devices to the guest user IDs.

### 2.6.2 HiperSockets

HiperSockets technology is available for System z servers. HiperSockets is an integrated any-to-any virtual TCP/IP network that provides inter connectivity among multiple LPARs or z/VM guests. With HiperSockets, you can connect any

server running on the same System z, and improve response time due to low latency.

HiperSockets was developed to provide highly available, high-speed network connections through a memory bus. It can be considered for an application or for infrastructure scenarios, where the network is stressed by a large quantity of data exchanged between servers running on the same System z server. It also provides higher security because packets do not leave the box so they cannot be *sniffed* on the LAN.

Figure 2-10 on page 46 shows a possible implementation of HiperSockets over an applications server scenario. When you use a Linux for System z technology to produce an application environment, you usually plan to have a three-layer architecture:

- ▶ Front layer is the HTTP server.
- ▶ Middle layer is the application server.
- ▶ Back-end layer is the database server.

With the proposed architecture, the environment can be planned with:

- ▶ IBM HTTP Server (powered by Apache) under Linux for System z
- ▶ IBM WebSphere Application Server under Linux for System z
- ▶ DB2® server under z/OS

If a session is started by a browser over the network, a communication between the three layers is started. To avoid network traffic, implementing a HiperSockets solution can help. With benefits provided by HiperSockets, your network traffic between the layers is exchanged in the System z server at memory speeds.

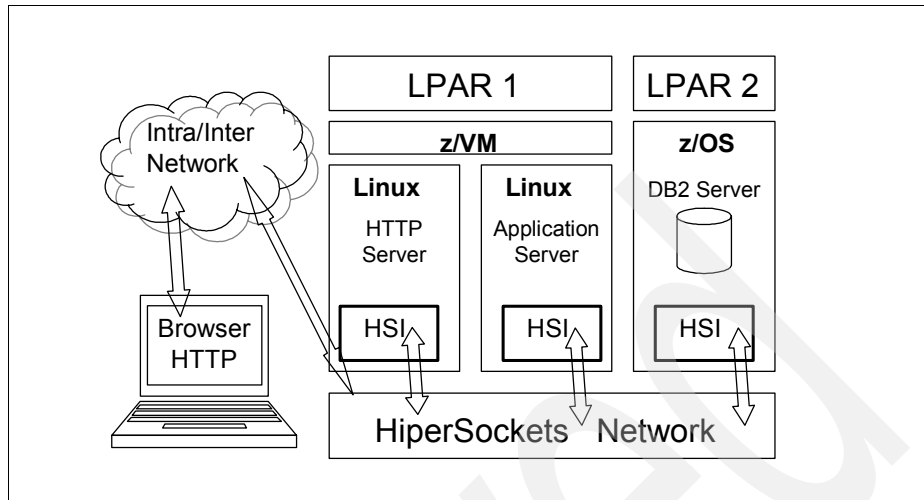

Figure 2-10 The application server scenario with HiperSockets

More information about HiperSockets is available in section 6.3, “Networking access” on page 301.

### 2.6.3 HiperSockets for fast LPAR communication

HiperSockets provides the fastest TCP/IP communication between consolidated Linux, z/VM, z/VSE, and z/OS virtual servers on a System z server. HiperSockets provides internal *virtual* local area networks, which act like TCP/IP networks within the System z server. This integrated Licensed Internal Code (LIC) function, coupled with supporting operating system device drivers, establishes a higher level of network availability, security, simplicity, performance, and cost effectiveness than is available when connecting single servers or logical partitions (LPs) together using an external TCP/IP network.

The HiperSockets function, also known as internal Queued Direct Input/Output (iQDIO) or internal QDIO, is an integrated function on the System z servers that provides users with attachment to high-speed *logical* LANs with minimal system and network overhead.

HiperSockets eliminates the need to use I/O subsystem operations and the need to traverse an external network connection to communicate between LPs in the same System z server. HiperSockets offers significant value in server consolidation connecting many virtual servers, and can be used instead of some coupling link configurations in a Parallel Sysplex®.

HiperSockets is customizable to accommodate varying traffic sizes. Because HiperSockets does not use an external network, it can free system and network resources, eliminating attachment costs while improving availability and performance.

### HiperSockets connectivity

HiperSockets are accessible among combinations of logical partitions (LPs) or virtual servers within the System z. This *network within the box* concept minimizes network latency and maximizes bandwidth capabilities between z/VM, Linux on System z, z/VSE, and z/OS images, or combinations of these. It is also possible to have HiperSockets under z/VM, which permits internal networks between guest operating systems, such as many Linux servers, for example.

Each HiperSockets LAN uses a Channel Path ID (CHPID) with a channel type IQD. Figure 2-11 shows an example of HiperSockets connectivity using four HiperSockets with CHPIDs FC, FD, FE, and FF.

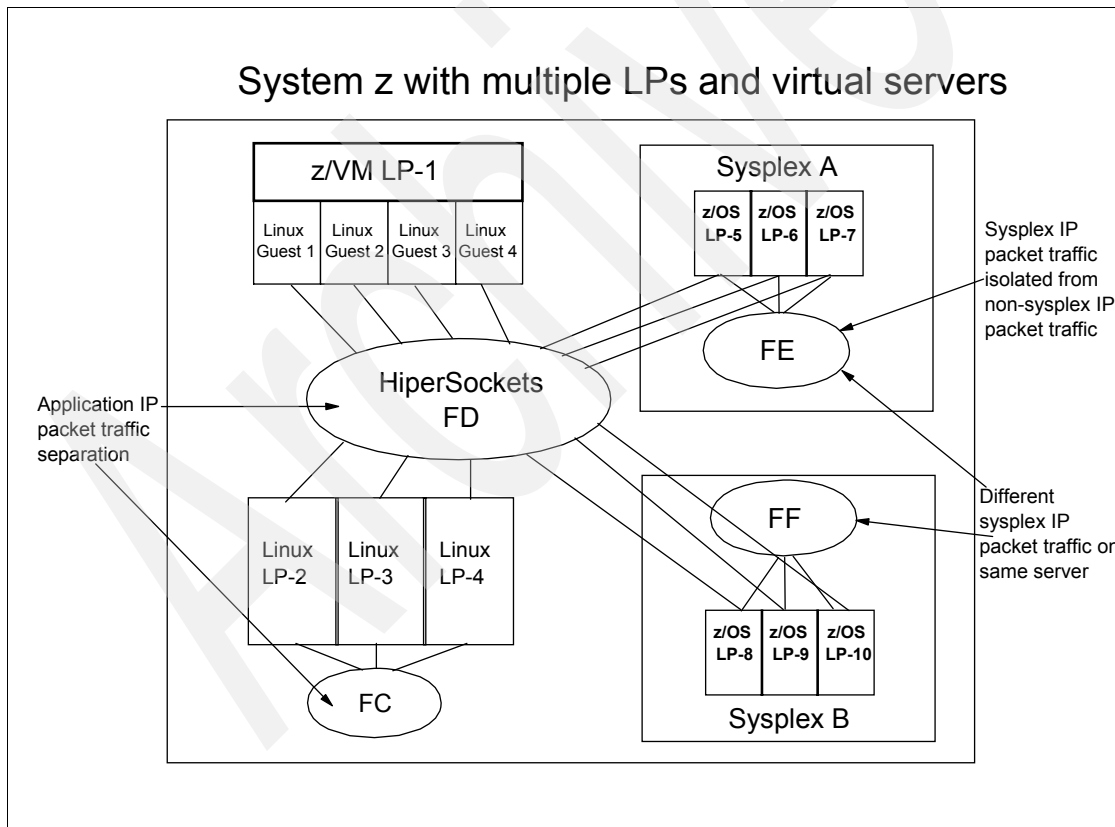

Figure 2-11 HiperSockets connectivity

## HiperSockets benefits

System z HiperSockets is a technology that provides high-speed TCP/IP connectivity between virtual servers running within different logical partitions (LPs) of a System z server. It eliminates the need for any physical cabling or external networking connections between these virtual servers.

The virtual servers form a *virtual LAN*. Using iQDIO, the communication between virtual servers is through I/O queues set up in the system memory of the System z server. Traffic between the virtual servers is passed at memory speeds. HiperSockets supports multiple virtual LANs, which operate as TCP/IP networks within a System z server. Section “HiperSockets connectivity” on page 47 discusses the number of HiperSockets available for each System z server.

HiperSockets is an LIC function of the System z server. It is supported by the following operating systems:

- ▶ All in-service z/OS releases
- ▶ All in-service z/OS.e releases
- ▶ All in-service z/VM releases
- ▶ All in service z/VSE releases
- ▶ Linux on System z

A number of benefits are gained when exploiting the HiperSockets function:

- ▶ HiperSockets can be used to communicate among consolidated servers in a single System z server platform. All the consolidated hardware servers can be eliminated, along with the cost, complexity, and maintenance of the networking components that interconnect them.
- ▶ Consolidated servers that have to access corporate data residing on the System z server can do so at memory speeds, bypassing all the network overhead and delays.
- ▶ HiperSockets can be customized to accommodate varying traffic sizes. (In contrast, LANs such as Ethernet and Token Ring have a maximum frame size predefined by their architecture.) With HiperSockets, a maximum frame size can be defined according to the traffic characteristics transported for each of the possible HiperSockets virtual LANs.
- ▶ Because there is no server-to-server traffic outside the System z server, a much higher level of network availability, security, simplicity, performance, and cost-effectiveness is achieved as compared with servers communicating across an external LAN. For example:
  - HiperSockets provides a very secure connection because it has no external components, it provides a very secure connection. For security purposes, servers can be connected to different HiperSockets. All security



features, like firewall filtering, are available for HiperSockets interfaces as they are for other TCP/IP network interfaces.

- HiperSockets looks like any other TCP/IP interface; therefore, it is transparent to applications and supported operating systems.
- ▶ HiperSockets can also improve TCP/IP communications within a sysplex environment when the DYNAMICXCF facility is used.

For an in-depth discussion on HiperSockets, refer to the *IBM System z Connectivity Handbook*, SG24-5444.

## 2.6.4 VSWITCH

Virtual switch, or VSWITCH, is the newest LAN type supported by z/VM. It was introduced in release 4.4 of z/VM and is a special type of guest LAN that can provide external LAN connectivity through HiperSockets or an OSA-Express device without requiring a routing virtual machine.

z/VM does require that one particular machine own the OSA-Express devices that are used by the VSWITCH. These special virtual machines are called VSWITCH controllers, and are essentially extra TCP/IP stacks that manage the OSA on behalf of the systems connected to the VSWITCH. Earlier releases of z/VM had a single predefined VSWITCH controller. Starting with z/VM 5.1 and newer versions have two predefined VSWITCH controllers: DTCVSW1 and DTCVSW2.

Another benefit of a VSWITCH is that it can easily be configured with redundant OSA devices and additional controllers so that in the event of a problem, either the switch can fail over to a backup OSA or controller.

Figure 2-12 on page 50 shows a logical view of a virtual switch and where it fits.

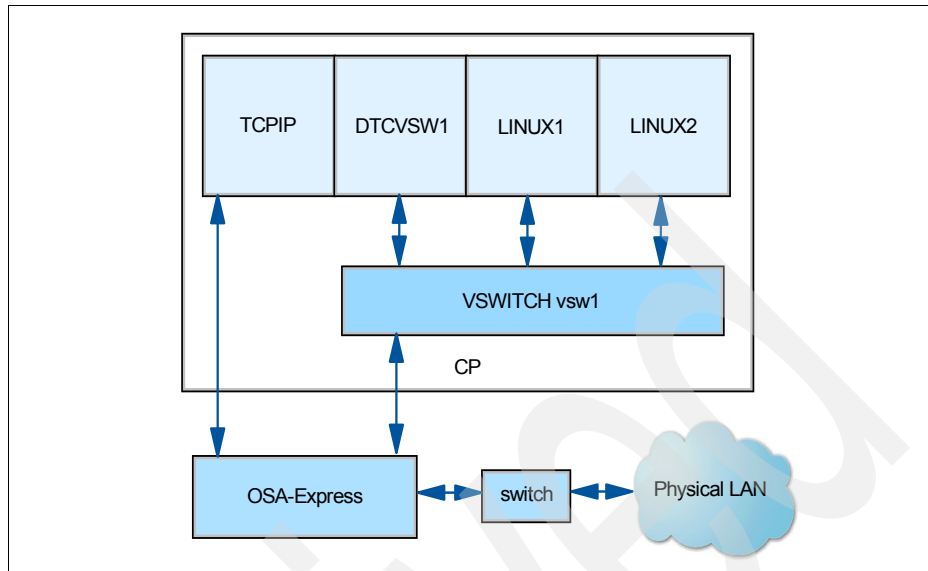

Figure 2-12 Architecture diagram for a virtual switch

## 2.6.5 Further information about networking

For more information about networking refer to the following publications:

- ▶ *Linux on IBM eServer zSeries and S/390: Large Scale Linux Deployment*, SG24-6824
- ▶ *Introduction to the New Mainframe: z/VM Basics*, SG24-7316
- ▶ *Networking Overview for Linux on zSeries*, REDP-3901

## 2.7 Consoles

As a z/VM operator, you might use several types of consoles. Consoles can be located on the same physical device, such as a PC workstation using 3270 emulator software or on physically connected 3270 terminals. Because of the flexibility of z/VM, the number of consoles varies by customer installation. Depending on your installation, there might be one production system or many production systems. Hundreds of virtual machines each could be running a production system. Regardless of the number of consoles, the following four types of consoles are available, which are described in the next sections:

- ▶ Hardware Management Console

- ▶ Primary system operator console
- ▶ Virtual Console for each virtual machine
- ▶ Production system's system console when an operating system such as Linux, z/OS, z/VM, z/VSE, or z/TPF, is running in a virtual machine.

Although the number of consoles at each site depends on the installation, each installation has at least one Hardware Management Console, at least one primary system operator console, and one or more virtual consoles to control virtual machines. A production system often has its own system console.

**z/OS analogy:** The Hardware Management Console and the primary system operator console are similar to the HMC, which is used to access a z/OS LPARs.

For more information about z/VM consoles and how to interact with each of them, see *z/VM: System Operation*, SC24-6121<sup>2</sup>.

## 2.7.1 The Hardware Management Console

A Hardware Management Console (HMC) communicates with each central processor complex (CPC). There can be one or more Hardware Management Consoles depending on your site's installation. This section describes only the specific tasks for the z/VM operator. For additional information about using the Hardware Management Console, see the processor complex hardware publications. The *System z Hardware Management Console Operations Guide*, SC28-6867 can be found at:

<http://www-01.ibm.com/support/docview.wss?uid=isg2bac11e0b02e3aa73852573f70056c860>

From the Hardware Management Console, you can:

- ▶ Perform an IPL of z/VM
- ▶ Monitor messages and send commands to z/VM (Operating System Messages panel)
- ▶ Perform basic z/VM system management functions
- ▶ Install, service, and operate z/VM using the integrated 3270 console

**z/OS analogy:** z/OS users should already be familiar with this type of console because it is also used to define LPARs, a common task between z/OS and z/VM, and to access a z/OS console.

<sup>2</sup> <http://publibz.boulder.ibm.com/epubs/pdf/hcsf2b30.pdf>

## Using the Operating System Messages panel

From the Hardware Management Console, you can use the Operating System Messages task (panel), which is the SYSC device, to log on to the OPERATOR user ID and view z/VM messages. You can also use the Operating System Messages panel to issue commands on the z/VM. This communication between the Hardware Management Console and z/VM is in line mode.

To use the Operating System Messages panel as the system operator console during the initial program load of the z/VM system, perform one of the following tasks (in the following list, refer to the named sections listed in *z/VM: CP Planning and Administration*, SC24-6083<sup>3</sup>):

- ▶ Specify the CONS=SYSC IPL parameter when using the stand-alone program loader (SAPL). See “Passing IPL Parameters.”
- ▶ Specify a load parameter of CONSSYSC to bypass the SAPL window and have the z/VM operator open on the Operator System Messages panel. See “Overriding Stand-Alone Program Loader Defaults.”
- ▶ Add SYSTEM\_CONSOLE to the OPERATOR\_CONSOLES statement in the SYSTEM CONFIG file. See “System Configuration File.”

To have emergency operating system messages displayed, add SYSTEM\_CONSOLE to the EMERGENCY\_MESSAGE\_CONSOLES statement in the SYSTEM CONFIG file.

## Setting up and using the Integrated 3270 console

From the Hardware Management Console you can use the integrated 3270 console as the system operator’s console. The integrated 3270 console is identified by z/VM as SYSG. This console provides you the ability to install, service, and operate z/VM without any attached 3270 devices. To identify the integrated 3270 console to CP during initial program load of the z/VM system, do one of the following tasks:

- ▶ Use the CONS=SYSG IPL parameter when using the stand-alone program loader (SAPL).
- ▶ Specify a load parameter of CONSSYSG to bypass the SAPL window and have the z/VM operator come up on the Integrated 3270 Console. See “Overriding Stand-Alone Program Loader Defaults” in *z/VM: CP Planning and Administration*, SC24-6083<sup>4</sup>.
- ▶ Add SYSTEM\_3270 to the OPERATOR\_CONSOLES system configuration statement.

<sup>3</sup> <http://www.vm.ibm.com/pubs/hcsg0b01.pdf>

<sup>4</sup> <http://www.vm.ibm.com/pubs/hcsg0b01.pdf>

## 2.7.2 The primary system operator console

The primary system operator console is the console where CP automatically logs on the system OPERATOR virtual machine during initial program load (IPL). This can be the Hardware Management Console, or a device specified during the IPL. If SYSC is specified, the Operating System Messages panel becomes the system operator console. If SYSG is specified, the integrated 3270 console becomes the system operator console. Your installation chooses the device or Hardware Management Console function (SYSC or SYSG) to be identified as the primary system operator console by using one of the following statement or parameters:

- ▶ SYSTEM CONFIG statement, OPERATOR\_CONSOLES
- ▶ IPL parameter, CONS=xxxx
- ▶ Load parameter CONSxxxx

The primary system operator console is where you perform most of the tasks in this book. For example, you enter CP commands from the primary system console to perform the following tasks:

- ▶ Opening the z/VM CP
- ▶ Shutting down the z/VM CP
- ▶ Controlling z/VM devices
- ▶ Communicating with z/VM users
- ▶ Responding to z/VM errors
- ▶ Collecting information about z/VM operation

After CP logs in to the system OPERATOR, it controls the format of the primary system console's screen. If you are unfamiliar with this format, see *z/VM: Virtual Machine Operation*, SC24-6128<sup>5</sup>.

## 2.7.3 The z/VM virtual consoles

Other consoles you use are the virtual consoles for the virtual machines from which you create and initialize work or production systems. Use this console when you:

- ▶ Log on a production system's virtual machine.
- ▶ Set up any special running environment it requires.
- ▶ Use the CP IPL command to load production systems in the virtual machine.
- ▶ Have to recover a production system.
- ▶ Control a production system's virtual machine.

<sup>5</sup> Found in the PDF at: <http://publibz.boulder.ibm.com/epubs/pdf/hcse8b11.pdf>

**Note:** To control the production system itself, use the production system's console.

When you log on to a production system's virtual machine at this console, CP controls the format of the console's window. If you are unfamiliar with this format, see *z/VM: Virtual Machine Operation*, SC24-6128<sup>5</sup>.

**Note:** For z/OS guests, when the system console is responding to z/VM errors or loading (IPL) the system, the virtual machine console can be used as an IPL and error-recording console. For more information see the books:

- ▶ *z/VM: Virtual Machine Operation*, SC24-6128  
<http://publibz.boulder.ibm.com/epubs/pdf/hcse8b11.pdf>
- ▶ *z/VM: Running Guest Operating Systems*, SC24-6115  
<http://publibz.boulder.ibm.com/epubs/pdf/hcsf8b22.pdf>

For details, refer to 2.7.5, “Getting to know your virtual console” on page 54.

## 2.7.4 The virtual machine guest systems console

When another operating system is running work in a virtual machine, this is referred to as a *guest system*. You use the guest system's system console to control the work, just as though you were running the guest system directly on the hardware. Some guest systems have their system console on the same physical device as the virtual machine operator's console; other installations might use separate devices.

## 2.7.5 Getting to know your virtual console

To log on to the z/VM system, use either of the following methods on the z/VM logon window (shown in Figure 2-13 on page 55):

- ▶ Type your user ID and password in the corresponding lines of the z/VM logon window, and then press Enter.
- ▶ Position the cursor in the COMMAND line, type LOGON followed by your user ID, and then press Enter.

For detailed logon information, refer to “Logging on” on page 59.

```

z/VM ONLINE

          / VV      VVV MM      MM
         /  VV      VVV  MMM     MMM
ZZZZZZ /   VV      VVV  MMMM    MMMM
      ZZ /    VV  VVV  MM MM MM MM
      ZZ /    VV  VVV  MM  MMM  MM
      ZZ /    VVVVV  MM  M  MM
      ZZ /    VVV    MM    MM
ZZZZZZ /     V      MM      MM

built on IBM Virtualization Technology

Fill in your USERID and PASSWORD and press ENTER
(Your password will not appear when you type it)
USERID  ====>
PASSWORD ====>

COMMAND  ====>

RUNNING  VMLINUX6

```

Figure 2-13 Logging on using the command line

The system prompts you for the password (see Example 2-3).

*Example 2-3 Prompt for the password*

---

```

LOGON MAINT
ENTER PASSWORD (IT WILL NOT APPEAR WHEN TYPED):

```

---

After logging on, the CP READ prompt appears. Press Enter again and the CP loads CMS. See Figure 2-14 on page 56.

CMS then executes the PROFILE EXEC file of the z/VM user ID, if it exists. In the PROFILE EXEC, you can define settings for your z/VM user ID. For example, settings can be defined for PF window keys, linking to MDISKS, or loading (IPL) a guest operating system such Linux or z/OS.

```
LOGON TCPMAINT
z/VM Version 5 Release 3.0, Service Level 0701 (64-bit),
built on IBM Virtualization Technology
There is no logmsg data
FILES: 0024 RDR, NO PRT, NO PUN
LOGON AT 14:50:27 EDT WEDNESDAY 06/13/07
z/VM V5.3.0 2007-05-02 16:25

DMSACC724I 191 replaces A (191)
Ready; T=0.01/0.01 14:50:28

RUNNING VMLINUX6

MA a 23/001
```

Figure 2-14 z/VM screen after logon

At this point, you are logged on to your z/VM virtual machine. Before discussing basic commands for checking your virtual machine, we discuss introductory information about VM commands.

In our description, we use the term command generically; it refers to both CP commands and CP utilities. z/VM uses command languages to correspond to the two environments it creates the control program and virtual machine.

Use the Control Program (CP) command language when:

- ▶ You are a z/VM system operator and you want to control the resources of the real machine located in your computer room.
- ▶ You are a virtual machine user and you want to control your virtual machine's configuration and environment.

Use a virtual machine command language when you communicate with the operating system you loaded into your virtual machine, as follows:

- ▶ To perform production or test work, load your virtual machine with one of the operating systems supported by the z/VM system. Your virtual machine command language is the command language of the operating system you load. This command language is described in the library that documents that particular operating system.



- ▶ To perform service, installation, and maintenance tasks, along with editing and text creation, communicating with others, and problem solving, load your virtual machine with the CMS, which is a single user, conversational operating system.

You can use CP commands in the following situations:

- ▶ Your virtual machine is in the Control Program (CP) command environment.  
Your virtual machine is in the CP environment when you log on to z/VM and CP READ is displayed in the lower right corner of the window.  
On a line-mode ASCII device, no status area is available to display CP READ, so CP is displayed in the output area.
- ▶ You press the Break key while in full-screen mode before entering a command.  
The break key can be PA1, the VM default break key, or another key that you have defined as the break key using the `TERMINAL BRKKEY` command. Also, the break key might be totally disabled by some application programs or when in the protected application environment.
- ▶ You are in a virtual machine command environment, not running in full-screen mode, and enter the `#CP` command (and # is your logical line end character).
- ▶ You are in the CMS virtual machine environment and enter the `CP` command.
- ▶ You are in the CMS virtual machine environment and have the `IMPCP` function set ON.

To determine the current command environment on a 3270 device, look at the status area in the lower right corner of the display. CP READ indicates the CP environment, VM READ indicates the virtual machine environment.

If you are running CMS in your virtual machine, VM READ indicates the CMS environment. When `RUNNING` appears in the status area, enter a null input line to determine your environment. To enter a null line, press Enter but do not enter any data. When you enter the null line, the status area displays either CP READ or VM READ.

Also, if you are in a read state, in either the CP command environment (with `RUN` set OFF) or the CMS command environment, and you enter a null line, the system responds with the name of your command environment: CP or CMS in the system output area.

You enter CP commands using any combination of upper case and lower case letters. Type the command and its operands, and then press Enter to process the command.

## Working with a 3270 terminal

Previously, we explained how to log on to the z/VM system, and you saw the response from the system. Now we discuss what you have to know when working with a 3270 terminal on a z/VM system.

Figure 2-15 shows the layout of the 3270 window.



Figure 2-15 Layout of the 3270 window

The three areas of the window are: Output display area, User input area, and Screen status area, as described in Table 2-1.

Table 2-1 Display areas

Area	Description
Output display area	<ul style="list-style-type: none"><li>▶ Consists of lines 1 to 22.</li><li>▶ All messages are displayed here.</li><li>▶ The commands you entered are displayed here.</li></ul>
User input area	<ul style="list-style-type: none"><li>▶ Consists of last two lines, excluding the right-most 21 character positions of the last line.</li><li>▶ Commands can be entered here.</li><li>▶ Cursor control keys, Delete key, Insert Key and logical text editing characters can be used to alter data in this area.</li><li>▶ After pressing Enter, CP redisplay the data entered here in the output display area.</li></ul>

Area	Description
Screen status area	<ul style="list-style-type: none"> <li>▶ Consists of the right-most 21 character positions of the last line.</li> <li>▶ Screen status indicators appear here.</li> <li>▶ Indicates whether the current environment is CP or VM.</li> <li>▶ The status displayed here can be one of the following values: <ul style="list-style-type: none"> <li>– CP READ indicates CP issued a read request to the display and is waiting for the user to enter something before it can continue processing.</li> <li>– VM READ indicates the virtual machine is awaiting a response from the user before it can continue processing.</li> <li>– RUNNING indicates CP or VM is either ready to accept commands, or is processing an already executed command.</li> <li>– MORE . . . indicates that the output display area is full but more data is available to display.<sup>a</sup> Display or do not display more data, as follows: <ul style="list-style-type: none"> <li>• CP waits 60 seconds (default) and then displays the next window.</li> <li>• Use the PA2 key (3270) to see the next screen without waiting 60 seconds.</li> <li>• Use the Enter key (3270) to keep the current screen (status changes to HOLDING).</li> </ul> </li> <li>– HOLDING indicates that user pressed Enter (3270) in response to MORE.</li> <li>– NOT ACCEPTED indicates that the previous input was not accepted (CP locks keyboard for 3 seconds).</li> </ul> </li> </ul>

a. Use SET FULLSCREEN ON from CMS if you want the scroll back option. This is disabled by default. (Note that this works only for CMS.)

## 2.7.6 Session management

Your session begins when you log on to the system, and it ends when you log off. This section describes logging on, logging out, and several other actions you can perform during a session.

### Logging on

Refer to Figure 2-13 on page 55 as you read through the following details in this section about logging on.

The logon screen contains three fields:

- ▶ USERID
- ▶ PASSWORD
- ▶ COMMAND

As mentioned in 2.7.5, “Getting to know your virtual console” on page 54, the two ways to log in are as follows:

- ▶ Enter your user name and password in the USERID and PASSWORD fields.

- ▶ Use the COMMAND line by issuing the CP LOGON command, which has many parameters that can customize how you log on to the system.

To use the COMMAND line, press the Tab key until your cursor is positioned on the COMMAND line. (You can also use the arrow keys or your mouse to manually move the cursor to the COMMAND line.)

On the COMMAND line, issue the LOGON command. The simplest use of the LOGON command is shown in Example 2-4.

*Example 2-4 Simple use of LOGON command*

---

LOGON TUX1

---

This command prompts you for a password. If the password you enter is correct, the system logs you on as user TUX1 just as though you had entered the user name and password in the USERID and PASSWORD fields.

**Notes:**

- ▶ If you type an incorrect user name or password on the logon screen, the normal input fields (USERID and PASSWORD) disappear and you are forced to use the LOGON command from the COMMAND line if you want to try to log in again. Therefore, knowing how to use the COMMAND line is important in case you insert a typographical error when you first try to log on.
- ▶ The CP LOGIN command is identical to the CP LOGON command. Both exist because some people prefer to use the term *log in* and others prefer *log on*.

## Disconnecting

CP provides a very useful feature known as disconnecting. You may *disconnect* your terminal from your virtual machine without stopping or interfering with the guest operating system running in your virtual machine in any way. This effectively severs your actual terminal session with the virtual machine (similar to logging off), but the virtual machine and its guest operating system continue to run. Use the DISC (or **disc**) command to disconnect, as shown in Example 2-5 on page 61.

**z/OS analogy:** z/OS has no similar command.

### *Example 2-5 Disconnecting from a guest*

---

**disc**

DISCONNECT AT 11:34:15 EDT WEDNESDAY 06/13/07

Press enter or clear key to continue

---

Use the QUERY NAMES command to determine which guests are disconnected. As shown in Example 2-6, disconnected guests have DSC displayed next to their names.

### *Example 2-6 Querying disconnected guests*

---

**QUERY NAMES**

```
EDI      -L0005, DIRMAINT - DSC , TCPIP      - DSC , RSCS      - DSC
PVM      - DSC , DATAMOVE - DSC , DTCVSW2    - DSC , DTCVSW1    - DSC
VMSERVV  - DSC , VMSERVU  - DSC , VMSERVS    - DSC , GCS       - DSC
OPERSYMP - DSC , DISKACNT - DSC , EREP       - DSC , OPERATOR - DSC
CLIVE    -L0008, MAINT    -L0004, EDI2      -L0006, JASON    -L0007
VSM      - TCPIP
```

---

When disconnecting from a guest, it is important to note your virtual machine's RUN parameter. If the RUN parameter is set to OFF when you disconnect (or reconnect), your guest operating system might be suspended, in some cases.

To prevent this from occurring, ensure that RUN is set to ON before you disconnect. Do this by using the SET command as shown in Example 2-7.

### *Example 2-7 Setting the RUN parameter to ON*

---

SET RUN ON

---

## **Reconnecting**

To reconnect to a disconnected virtual machine, perform a normal logon and you will be reconnected. After you are logged on, you might have to reinitiate the session with your guest system by entering the BEGIN command.

## **Stealing a virtual machine session**

If you ever have to log on to a virtual machine but it is already logged on to another terminal, a message is displayed, similar to the one in Example 2-8 on page 62.

*Example 2-8 Logon failed because guest is already logged in*

---

**LOGON TUX1**

HCPLGA054E Already logged on LDEV L0008

---

In this case, you may perform an action known as *stealing* the session. To steal the virtual machine session, use the HERE parameter with the LOGON command, as shown in Example 2-9.

*Example 2-9 Stealing a virtual machine session*

---

**LOGON TUX1 HERE**

RECONNECTED AT 11:48:17 EDT WEDNESDAY 06/13/07

---

The example shows that we have stolen the session from the other terminal connected to TUX1. What actually happens is that CP disconnects the other user session and then immediately connects to your terminal. Anything that was displayed on the screen or running before the disconnection will appear in your window after the reconnection.

**z/OS analogy:** This is similar to the TSO logon with the RECONNECT parameter in z/OS.

### Logging out

When you are finished running your virtual machine, you can log out by using the LOGOFF command. This causes your virtual machine to terminate and shut down until you log on again. CP removes the virtual machine and its defined resources from its device list until the next time you log on to the virtual machine. Logging off immediately terminates any guest operating system that is running.

## 2.7.7 Terminal management

Your virtual terminal is represented by your terminal emulator. A *terminal emulator* is the program you are looking at when you issue commands to CP and read the results. The terminal emulator display is typically a black background with green text. CP provides several ways for you to modify the terminal's display and behavior.

**Note:** To make the changes to your terminal persistent, place the commands shown in the next sections into your user's PROFILE EXEC file.

## Setting the clear screen timeout

You might have noticed that when your screen fills up, CP displays the text `More...` in the lower right corner of the screen and waits for you to press the key on your keyboard that *clears* the screen before displaying more output.

**Note:** Clearing the screen on a 3270: use the Pause (Break) key; with IBM Personal Communications 3270 emulator software, right -click the mouse on the screen and select **Clear**.

By default, CP waits 60 seconds for you to clear the screen before clearing it automatically. To customize this behavior use the `TERM MORE` command and with the timeout parameters, described in Table 2-2:

```
TERM MORE t1 t2
```

Table 2-2 *TERM MORE* command parameters

Parameter	Description
t1	The number of seconds that CP waits before sounding a bell to alert you that the screen will automatically clear. The default is 50 seconds.
t2	The number of seconds after the bell is sounded before the auto-clear actually takes place. The default is 10 seconds.

To prevent CP from holding the screen and forcing you to press the clear key, set both timeouts to zero (0) seconds:

```
TERM MORE 0 0
```

Keep in mind, however, that by setting the timeouts to zero, you might not have time to read all of the messages displayed on the terminal. In some cases, this might be acceptable (for example, if you are running a command or a program that is generating a large amount of output that you do not care about).

To return to the default behavior of 60 seconds (50 seconds before the bell, 10 additional seconds before the clear), use the following command:

```
TERM MORE 50 10
```

**Note:** The maximum value you can specify for both timeouts is 255 seconds. This means that the maximum wait before an auto-clear is 8 minutes and 30 seconds.

## Highlighting user input

The CP TERM command has a parameter that causes all user input (that is, all text that you specifically enter) to be highlighted in a color different from the color used for other text output.

To enable highlighting, use the TERM HILIGHT ON command. Any command you enter after this will be highlighted in a different color on the screen. Enabling a color change helps you to visually separate input from output and generally makes your terminal text easier to read.

To disable highlighting, use the TERM HILIGHT OFF command.

## Changing screen colors

You can change the colors that CP uses to display input, output, and status on your 3270 terminal emulator window by using the SCREEN command, with parameters described in Table 2-3:

SCREEN area-output color effect

Table 2-3 SCREEN command parameters

Parameter	Description
area	The area of the screen you want to change. Valid areas or output types are listed in Table 2-4.
color	The color you want to use for the text in the chosen area. Valid colors are: <ul style="list-style-type: none"><li>▶ BLUE</li><li>▶ TURQUOISE</li><li>▶ RED</li><li>▶ PINK</li><li>▶ GREEN</li><li>▶ WHITE</li><li>▶ YELLOW</li></ul>
effect	The effect you want to apply to the text in your chosen area. Valid effects are listed in Table 2-5.

Table 2-4 on page 65 lists the valid areas and output formats for the SCREEN command.



Table 2-4 Valid areas and output formats for the SCREEN command

Area or output	Description
INAREA	The command line area where you issue commands to CP and guest operating systems.
STATAREA	The display of the terminal status at the bottom of the screen.
OUTAREA	The area where messages from CP and guest operating systems are placed for you to see. The majority of the screen is this area.
CPOUT	This causes all messages from CP to be formatted as specified in the parameters of the command.
VMOUT	This causes all messages from a guest operating system to be formatted as specified in the rest of the command.

Table 2-5 lists the valid effects for the SCREEN command.

Table 2-5 Valid effects for the SCREEN command

Effect	Description
BLINK	This causes the text on the screen to blink.
REVVVIDEO	Reverse video swaps the text color and the background color. For example, green text on a black background becomes black text on a green background with the reverse video effect applied.
UNDERLIN	This causes the text to be underlined.
NONE	This causes no effects to be applied. It prints the text normally in the color specified.

**Note:** To reset your terminal to the default state, use the following SCREEN command:

```
SCREEN ALL DEFAULT
```

## 2.8 Getting started with basic commands for z/VM

This section describes basic commands for navigating in your z/VM system. For more details on the topics discuss here refer to the IBM Redbooks publication, *Introduction to the New Mainframe: z/VM Basics*, SG24-6366.

## 2.8.1 CP

Interaction with CP is primarily through a command line interface. You issue commands to CP by typing them on the command line and pressing Enter to submit them for processing.

CP commands are always from 1 to 12 characters in length, and are not case-sensitive. A command often accepts parameters, all of which are separated by a space (as in most command line environments).

Many commands can be abbreviated but are more cryptic. For example, the QUERY NAMES command can be shortened to **Q N**. Executing either version of the command accomplishes the same task.

This chapter always uses the complete command and not the abbreviation. If you want to know the abbreviation for a command, refer to the **help** command or to *CP Commands and Utilities Reference*, SC24-6073.

### Getting to CP mode

After logging in, any number of things could be going on, depending on the guest operating system your virtual machine is running. Because we are only interested in CP at this point, in our scenario we are going to shut down the guest operating system that is running and get into CP mode so we can issue commands directly to CP.

Your virtual machine is likely to be running the CMS operating system. To determine if you are running CMS, look at the output you get when you log on. If the output is similar to Example 2-10, you are running CMS. The last line (starting with `z/VM V5.3.0`) is the first line of output from CMS.

*Example 2-10 Output seen when running CMS at logon*

---

```
z/VM Version 5 Release 3.0, Service Level 0701 (64-bit),  
built on IBM Virtualization Technology  
There is no logmsg data  
FILES: 0001 RDR, NO PRT, NO PUN  
LOGON AT 09:54:43 EDT MONDAY 06/04/07  
z/VM V5.3.0 2007-05-02 16:25
```

---

If no output appears, you might still be running CMS. Enter the QUERY CMSLEVEL command to check further. If the output is similar to Example 2-11 on page 67, then you *are* running CMS.

*Example 2-11 Output from QUERY CMSLEVEL command*

---

**QUERY CMSLEVEL**

CMS Level 23, Service Level 701  
Ready; T=0.01/0.01 09:57:17

---

**Important:** To stop CMS and enter CP mode, issue the #CP SYSTEM CLEAR command. Note, however, that if you are *not* running CMS, this command can work, but it could damage your guest operating system. Issuing a SYSTEM CLEAR command is the equivalent of pulling your desktop personal computer's power cord out of the wall socket. It halts the system immediately and does not give the operating system a chance to finish what it is doing and perform cleanup tasks. If the operating system is engaged in writing a file when this happens, you could lose the contents of the file or even permanently corrupt the file system.

Therefore, if you are *not* running CMS, consult your guest operating system's manual for proper shutdown instructions.

**z/OS analogy:** For z/OS users this is like doing a SYSTEM RESET on the HMC for your LPAR

*Example 2-12 Output from #CP SYSTEM CLEAR command*

---

**#CP SYSTEM CLEAR**

Storage cleared - system reset.

---

This command clears your virtual machine's memory, and stops and resets all of its virtual processors.

If you are truly in CP mode and not running a guest operating system, you should be able to issue the BEGIN command and see the output displayed in Example 2-13.

*Example 2-13 Output of BEGIN command when not running a guest operating system*

---

**BEGIN**

HCPGIR453W CP entered; program interrupt loop

---

If different content is displayed, chances are you are still running a guest operating system.

## Examining your virtual machine

CP has many commands that involve getting information about your virtual machine and defining its virtual hardware configuration. In this section, we examine the commands for obtaining information about your virtual machine.

First, we discuss the QUERY command, which provides useful information about your virtual machine and the system on which it is running. The command accepts several arguments, most of which have sub-arguments of their own. We will only look at a subset of the capabilities of the query command.

**z/OS analogy:** Query is similar to the various DISPLAY commands in z/OS

### CP version

The QUERY CPLEVEL command indicates which version of CP you are running. You run this command when you log on to your virtual machine. Version is commonly referred to as *level* in z/VM terminology. See Example 2-14.

**z/OS analogy:** For z/OS, the similar information is displayed when system command D IPLINFO is issued. It can also be displayed from variables in TSO and ISPF.

*Example 2-14 Output from QUERY CPLEVEL command*

---

#### QUERY CPLEVEL

```
z/VM Version 5 Release 3.0, service level 0701 (64-bit)
Generated at 05/02/07 16:28:04 EDT
IPL at 05/03/07 13:06:26 EDT
```

---

### Your guest name

If you just logged in, you probably know what your guest name is (a *guest name* is the uniquely identifying name given to your virtual machine). But, if you have more than one terminal open at the same time and forget which terminal goes with which guest, you can use the CP command QUERY USERID to determine the guest name; see Example 2-15.

**z/OS analogy:** In z/OS (when logged into ISPF), your user ID is normally displayed in the primary option panel

*Example 2-15 Output from the QUERY USERID command*

---

#### QUERY USERID

```
TUX1    AT VMLINUX6
```

---

The QUERY USERID command also tells you which node you are on. The term *node* refers to the instance of the z/VM operating system on which your guest is running. In this case, VMLINUX6 is the name given to the z/VM instance that the TUX1 guest is running on. When your system administrator installed z/VM, the administrator set the node name.

**Note:** The terms *virtual machine*, *guest*, and *user* all refer to a virtual machine. We use these terms interchangeably throughout this book.

## Your virtual machine's resources

Your virtual machine (as any computer) has a three types of resources: processor (CPU), memory (storage), and devices. The QUERY command lists basic information about your virtual machine, and information about these resources.

### Query virtual CPUs

Use the QUERY VIRTUAL CPUS command to display which virtual CPUs are defined for your virtual machine; see Example 2-16.

*Example 2-16 Output from the QUERY VIRTUAL CPUS command*

---

```
QUERY VIRTUAL CPUS
CPU 00  ID  FF02991E20948000 (BASE) CP  CPUAFF ON
```

---

This example indicates one virtual CPU. If you have more than one CPU, your output will include an additional line for each additional CPU that you have.

### Query virtual storage

Use the QUERY VIRTUAL STORAGE command to display the amount of storage (or RAM) your virtual machine has. (z/VM refers to RAM as *storage*. We use the term storage to refer to RAM throughout this book, unless otherwise specified.)

The output in Example 2-17 shows that our virtual machine has 32 M of storage. The amount of storage is given in kilobytes (K), megabytes (M), gigabytes (G), or terabytes (T).

*Example 2-17 Output from the QUERY VIRTUAL STORAGE command*

---

```
QUERY VIRTUAL STORAGE
STORAGE = 32M
```

---

### Query virtual all

Use the QUERY VIRTUAL ALL command to display a list of all devices on your virtual machine; see Example 2-18 on page 70.

Example 2-18 Output from the QUERY VIRTUAL ALL command

---

```
QUERY VIRTUAL ALL
STORAGE = 32M
XSTORE = none
CPU 00 ID FF02991E20948000 (BASE) CP  CPUAFF ON
No AP Crypto Queues are available
CONS 0009 ON LDEV L0007  TERM STOP  HOST TCPIP  FROM 10.0.0.1
      0009 CL T NOCONT NOHOLD COPY 001  READY FORM STANDARD
      0009 TO TUX1  PRT DIST TUX1  FLASHC 000 DEST OFF
      0009 FLASH  CHAR  MDFY  0 FCB  LPP OFF
      0009 3215  NOEOF CLOSED  NOKEEP NOMSG NONAME
      0009 SUBCHANNEL = 0001
RDR  000C CL * NOCONT NOHOLD  EOF  READY
      000C 2540  CLOSED  NOKEEP NORESCAN  SUBCHANNEL = 0002
PUN  000D CL A NOCONT NOHOLD COPY 001  READY FORM STANDARD
      000D TO TUX1  PUN DIST TUX1  DEST OFF
      000D FLASH  000 CHAR  MDFY  0 FCB
      000D 2540  NOEOF CLOSED  NOKEEP NOMSG NONAME
      000D SUBCHANNEL = 0003
PRT  000E CL A NOCONT NOHOLD COPY 001  READY FORM STANDARD
      000E TO TUX1  PRT DIST TUX1  FLASHC 000 DEST OFF
      000E FLASH  CHAR  MDFY  0 FCB  LPP OFF
      000E 1403  NOEOF CLOSED  NOKEEP NOMSG NONAME
      000E SUBCHANNEL = 0004
DASD 0190 3390 LX6RES R/O 107 CYL ON DASD  CD31 SUBCHANNEL = 0005
DASD 0191 3390 DKCD37 R/W 005 CYL ON DASD  CD37 SUBCHANNEL = 0000
DASD 019D 3390 LX6W01 R/O 146 CYL ON DASD  CD32 SUBCHANNEL = 0006
DASD 019E 3390 LX6W01 R/O 250 CYL ON DASD  CD32 SUBCHANNEL = 0007
DASD 0401 3390 LX6W01 R/O 146 CYL ON DASD  CD32 SUBCHANNEL = 0009
DASD 0402 3390 LX6W01 R/O 146 CYL ON DASD  CD32 SUBCHANNEL = 0008
DASD 0405 3390 LX6W01 R/O 156 CYL ON DASD  CD32 SUBCHANNEL = 000A
```

---

Each virtual device in your virtual machine has a virtual device number (commonly referred to as a *virtual device address*) that is specific to your virtual machine. In the example, 191 is the virtual device number for the minidisk on DASD pack (disk) labeled DKCD37. The address 0009 is the virtual console device that is used by your terminal session.

But the point here is to recognize that there are a variety of virtual devices, including some DASD packs, a punch card reader, and a printer. You might also have other devices, depending on how your virtual machine is defined.

### Privilege classes

CP uses *privilege classes* to regulate the types of things that virtual machines are allowed to do.

**z/OS analogy:** The concept of privilege class or similar does not exist in z/OS from the operating system perspective. This concept (or similar) would have to be assigned in RACF or a similar product. The UNIX System Services component of z/OS, however, has permissions set in its file system.

The privilege classes are conceptually similar to *permissions* in a Linux environments.

When your system administrator created your virtual machine, the administrator assigned you a certain subset of the privilege classes available on the system. Each privilege class is denoted by either a single letter or a single number, each one defining a certain role for the user having that class.

The IBM default privilege classes are A to G, and all except class G define certain system administrator roles. Class G defines the general user and is the default class for users that have no administrative capability. It is the most restrictive class.

Use the QUERY PRIVCLASS command to list the privilege classes for which your virtual machine is authorized; Example 2-19 shows output from this command.

*Example 2-19 Output from the QUERY PRIVCLASS command*

---

**QUERY PRIVCLASS**

```
Privilege classes for user TUX1
Currently: G
Directory: G
```

---

This means that your virtual machine can execute any command that is valid for class G users. Because the set of commands in any given privilege class is customizable by the system administrator, the set of commands you are able to run might vary slightly from the example.

CP also provides a command, QUERY COMMANDS, that lists all commands available to you, so having to remember your privilege classes or which commands go with them is unnecessary. Example 2-20 displays output from the command QUERY COMMANDS.

*Example 2-20 Output from the command QUERY COMMANDS*

---

**QUERY COMMANDS**

ADSTOP	ATTN	BEGIN	CHANGE	CLOSE	
COMMANDS	COUPLE	CPFORMAT	CPU	DEFINE	DETACH
DIAL	DISCONNECT	DISPLAY	DUMP	ECHO	EXTERNAL

FOR	INDICATE	IPL	LINK	LOADVFCB	LOCATEVM
LOGON	LOGOFF	MESSAGE	NOTREADY	ORDER	PURGE
QUERY	READY	REDEFINE	REQUEST	RESET	RESTART
REWIND	SCREEN	SEND	SET	SIGNAL	SILENTLY
SLEEP	SMSG	SPOOL	SPXTAPE	STOP	STORE
SYSTEM	TAG	TERMINAL	TRACE	TRANSFER	UNCOUPLE
UNDIAL	VDELETE	VINPUT	VMDUMP	XAUTOLOG	XSPPOOL
DIAG00	DIAG08	DIAG0C	DIAG10	DIAG14	DIAG18
DIAG20	DIAG24	DIAG28	DIAG40	DIAG44	DIAG48
DIAG4C	DIAG54	DIAG58	DIAG5C	DIAG60	DIAG64
DIAG68	DIAG70	DIAG7C	DIAG88	DIAG8C	DIAG90
DIAG94	DIAG98	DIAG9C	DIAGA0	DIAGA4	DIAGA8
DIAGB0	DIAGB4	DIAGB8	DIAGBC	DIAGC8	DIAGD0

---

As you can see in Example 2-20 on page 71, even for a class G user (which by default is the most restrictive permission class) many commands are available. The entries starting with DIAG represent diagnose functions that your virtual machine can call. A *diagnose function* is used by programmers and is similar to a Windows API call or a Linux system call. You cannot execute these by specifying the name on the command line.

If you are logged on to a user ID with class B privileges, you can determine which privilege class is necessary to execute a specific CP command by using the QUERY COMMANDS command with the specific command as an additional parameter, as shown in Example 2-21, using the ATTACH command.

*Example 2-21 QUERY COMMANDS ATTACH output*

---

```
q commands attach
ATTACH          IBMCLASS=B
Ready; T=0.01/0.01 15:09:46
```

---

## 2.8.2 CMS

Like any operating environment, CMS has commands for working with files. This section lists the common file management commands used by CMS users.

Commands are not case-sensitive. However, where we show a full command with partial uppercase characters, we are simply indicating which part of the full command can be abbreviated. For example, the **FILELIST** command can be entered in full, as **filelist**, or can be abbreviated, as **filel**.



## The FILEList command

One of the most useful CMS commands, FILEList allows you to list what is stored on a minidisk and to look for files by yielding a list of matching results.

**z/OS analogy:** Similar to z/OS ISPF option 3.4 except that TSO/ISPF users do not have a file system as such. The user would have to know the name of the data set to be manipulated. The TSO command ISRDDN lists all data sets allocated to your TSO/ISPF session lets you manipulate them. ISPF option 11 (Workplace™) is also a close equivalent.

The command syntax is:

```
FILEList filename filetype fm ( options
```

The `filename` parameter is the name of the file. Only the files whose names match the file name supplied are listed. The `filetype` parameter denotes the type of file<sup>6</sup>. The `fm` parameter denotes the file mode<sup>7</sup> or directory ID. A more in-depth discussion about the three parameters (*triplet*) is in section 4.2.4, “Dealing with disks” on page 129.

Listing files for which you already know the name is not that useful. You might want to determine which files are on a directory ID, or which files have the same name or type, or maybe you want to do all of these together. To accomplish that, use the asterisk (\*) as a wildcard. For example, to list all files in file mode A, you would type:

```
filel * * a
```

The result, in Figure 2-16 on page 74, shows that the *A* file mode has only one file, the PROFILE EXEC file. Notice the triplet is PROFILE EXEC A.

---

<sup>6</sup> A file type is known in systems such as Linux to be the file extension.

<sup>7</sup> A file mode or directory ID is the disk on which the file is to be found.

```

CERON  FILELIST A0 V 169 Trunc=169 Size=1 Line=1 Col=1 Alt=0
Cmd Filename Filetype Fm Format Lrecl Records Blocks Date Time
  PROFILE EXEC A1 V 66 19 1 5/09/08 14:53:47

1= Help 2= Refresh 3= Quit 4= Sort(type) 5= Sort(date) 6= Sort(size)
7= Backward 8= Forward 9= FL /n 10= 11= XEDIT/LIST 12= Cursor

====>
X E D I T 1 File

```

Figure 2-16 File listing using the FILEList command

Note that a file is denoted by a triplet composed of file name, file type and file mode. Users of Linux and other current systems would be familiar with the first two, which are analogous to the *filename.extension* scheme in those systems. The new paradigm here is the file mode itself.

z/OS analogy: In z/OS the dataset name is like the filename in z/VM. z/OS best practices try to include a description of the file type and file owner. The z/OS file name high level qualifier can be considered similar to the z/VM file mode.

The file mode could be seen as the location of the file, basically denoting on which disk it is located. This field is analogous to the path in systems such as Linux, with the exception that it is composed of a single letter that denotes a disk. The CMS file system has no concept of directories.

Note also the first column of the **FILEList** command output, which says cmd. You can actually input file management commands there, such as **erase**, and then press Enter to process the command. This saves time when managing files.

When issuing commands, you might forget to specify the various optional parameters, such as the replace parameter to **COPYfile** when you want to overwrite a file, or you might request **FILEList** to list a file mode that does not exist within your user space. In those cases, an error message code appears followed by a message that might not be enough information to help you determine what went wrong. To get help, however, type `help error_code` at the CMS prompt, where `error_code` is the code of the error you received. For

example, if you type `help dmslst069e`, which is the error code for a non-existent file mode, a help window opens as shown in Figure 2-17.

```
MSG DMSLST069E                All Help Information line 1 of 43
(c) Copyright IBM Corporation 1990, 2007

DMS069E <Output filemode|Filemode|Disk|Directory>
        <vdev|volid|mode((vdev)|dirname> (is) not accessed(;
        access_authority|access_authority)

Explanation: The specified disk, directory, or file mode has not been
accessed. If "Disk" is displayed and the disk is accessed, it may
not be correctly formatted for the command entered. (For example,
the command is trying to write a CMS-formatted file on an
OS-formatted disk.)

For the CMSDESK command, a R/W disk with file mode A is needed.

For the RECEIVE command, one of the following occurred:

    o A read-only file mode was specified on the RECEIVE command and
the file cannot be written onto this file mode.

    o RECEIVE attempted to read in a file sent using the DISK DUMP
command (or SENDFILE with the 'OLD' option), and in order to use
DISK LOAD to read the file in, file mode A must be accessed in
read/write mode.

PF1= 2= Top 3= Quit 4= Return 5= Clocate 6= ?
PF7= Backward 8= Forward 9= PFkeys 10= 11= 12= Cursor

====>

Macro-read 1 File
```

Figure 2-17 Getting help about an error code

## The COPYfile command

The basic COPYfile command (abbreviated as COPY or copy) copies a file from one location to another. Specify the source and destination file names, file extensions, and file modes. Though this might sound a bit trivial, it is very important to the CMS user.

Typically, CMS users have *read* access, allowing them to look at and list files that are on read-only disks. To change those files, a CMS user must first copy them to

a read-write disk. The command that allows this is the COPYFILE command. The syntax is:

```
COPYfile fileid1 (fileid2 .. fileidn) ( options
```

A simple example is to issue:

```
copyfile duane txt a secret data d
```

This makes a copy of the file duane.txt on your A disk and stores it as the file secret data on your D disk.

However, you do not always have a D disk, or it might not always allow you to write files to it. In such cases, you will receive an appropriate error message. (Note that the original file is not erased.)

The COPYFILE command is one of the most powerful CMS commands. In addition to the basic copying operations described, this command allows you to specify multiple input files, copy specific columns to new positions, insert fixed data in the file, select ranges from records to copy, and perform other actions. For example, the following command copies the file MARK.TXT from the system (or S) disk to your A disk:

```
COPY MARK.TXT S = = A
```

Another example invocation of the command is:

```
copyfile duck list c finch = = warbler = a birds file a (append
```

This example combines the files duck list and finch list on your C disk, and the file warbler list on your A disk, and adds the new combined file to the end of the file birds file a, which already exists. This form of the command is similar to using the **cat** and **>>** command combination in the Linux operating systems.

The COPYFILE command has additional useful options. The following example copies files from your S disk to your A disk, while ensuring that the time stamp on the system file is preserved:

```
COPY ALL XEDIT S = = A (OLDDATE  
FILE 'ALL XEDIT A2' ALREADY EXISTS -- SPECIFY 'REPLACE'
```

This example illustrates a common error that occurs when the output file ID already exists (for instance, after a previous copy operation in which the user neglected to keep the time stamps). In such a situation, you must reissue the COPY command with another option, as shown:

```
COPY ALL XEDIT S = = A (OLDDATE REPLACE
```

The open parenthesis in all of these examples is a CMS convention, and actions that change the default operation of a command (that is, options) are placed after it. A closing parenthesis is not required.

**z/OS analogy:** An analogy in z/OS is to allocate the target file using ISPF option 3.2 prior to copying using option 3.3. It would also be possible to create a copy of a file from within a ISPF EDIT session.

### The ERASE command

The ERASE command removes files from disk storage, releasing space for other uses. It deletes a file, and the space that the file occupied is immediately reusable. The syntax of the ERASE command is:

```
ERASE fn ft (fm) ( options
```

For example, the following command deletes the file frank tdata on your A disk:

```
erase frank tdata a
```

**Important:** The ERASE command provides an immediate, irrevocable deletion of the file data. It assumes that the file is on your A disk unless you specify otherwise.

## 2.8.3 XEDIT

The previous sections discussed how to examine your accessed disks and work with files at the file system level. But what about editing at the file level? Creating and changing content is an important part of the CMS user's skill set. This section introduces the utility most commonly suited for editing files on a CMS system.

Editing means changing, adding, or deleting data in a CMS file. You make these changes interactively with the *editor*; that is, you instruct the editor to make a change, the editor makes it, and then you request another change.

XEDIT is the name of the CMS editor, and is one of the most flexible and powerful utilities provided with CMS. The shortest abbreviated command used to edit a file with XEDIT is X followed by the file name, for example:

```
X PROFILE EXEC
```

The full command invocation of the same example is:

```
XEDIT PROFILE EXEC A
```

**z/OS analogy:** The z/OS equivalent is ISPF edit.

The command region is a single line at the bottom of the terminal. Here, you can issue commands such as SAVE, FILE, and QUIT. If you type anything into the edit region, which occupies the bulk of the window, you are modifying the loaded file. This can frustrate new CMS users who are not used to command and data being manipulated the same way.

**Important:** Pressing Enter at any time brings your cursor directly to the command line, but any text already on the command line is executed!

## The XEDIT window layout

The basic XEDIT window has the following regions: a file identification line, a message line at the top that gives information about the file being edited, an edit area, a prefix area, current line, and command area.

This section describes the various areas of the XEDIT window, and explains what each is used for. To follow along, invoke the following command:

```
xedit profile exec a
```

### ***File identification line***

The file identification line, which is the first line in the window, identifies the file you are editing. The display shows information about the file name, file type, file mode of the current file.

If you do not specify a file mode, the editor assigns a file mode of A1. The file mode identifies an accessed minidisk or Shared File System (SFS) directory where the file resides.

After you type `xedit profile exec a`, you will see the file record format and record length (V 132) on the first line at the top of the XEDIT window. The record format and record length indicate the format of the line and the maximum length of the line. For example V 132 indicates a maximum record length of 132 characters with a variable (V) line length. Note that a file line can be longer than a window line.

The truncation column is the same as the record length (132). Because a file line can be only 132 characters long, any data you enter beyond 132 characters (in total) can be truncated. Additionally, you can see information about the current number of lines in the file. You also see the alteration count, which indicates the number of lines modified since the last autosave.

### ***Message line***

The editor communicates with you by displaying messages on the second and third lines (the message lines) of the window. These messages provide information including whether you have made an error.

### ***Edit area***

The edit area displays the file. You can make changes to the file by moving the cursor to any line and typing over (retyping) the characters, or by using special keys on a standard 3270 emulation keyboard to insert or delete characters.

You can make as many changes as you want on the displayed lines before pressing Enter. When you press Enter, the changes are made to the copy of the file that is kept in virtual storage.

At the end of the editing session, a FILE command permanently records those changes on the copy of the file that resides on disk or directory. Because a file can be too long to fit on one window, various subcommands scroll the window so you can move forward and back in a file. Scrolling the window is like turning the pages of a book.

### ***Prefix area***

The prefix area consists of the five left-most columns on the window. Note that each line in the file has a prefix area.

The area might display five equal signs (====), or sometimes line numbers, depending on the particular configuration of XEDIT being used. In some cases the prefix area has no special marker at all.

You can perform various editing tasks, such as deleting a line, by entering short commands called *prefix subcommands* in the prefix area of a line, for example:

====a	Adds one line
a====	Adds one line
3 a==	Adds three lines
5a===	Adds five lines
==d==	Deletes one line

**z/OS analogy:** The prefix subcommands in XEDIT are the equivalent of line commands in the ISPF editor.

### ***The current line***

The current line is the file line in the middle of the window (above the scale). It is highlighted, appearing brighter than the other file lines. The current line is an important concept, because most subcommands perform their functions starting with the current line.

The line that is current changes during an editing session as you scroll the window, move up and down, and so forth. When the current line changes, the line pointer (not visible on the window) has moved. Many XEDIT subcommands perform their functions starting with the current line and move the line pointer when they are finished.

**Note:** Sometimes XEDIT is configured to show a scale, which appears under the current line, to help you edit. It is like the margin scale on graphical text editors.

### ***Command area***

The large arrow (====>) displayed at the bottom of the window points to the command input area. One way you communicate with the editor is to enter XEDIT subcommands on this line. You can type subcommands in upper case or lower case or a combination of both, and many can be abbreviated. For example, the following formats are all valid for the BOTTOM subcommand:

- ▶ BOTTOM
- ▶ Bottom
- ▶ b

To execute a subcommand, type it on the command line and then press Enter. To move the cursor from any place on the window to the command line, either press Enter or use PF12.

### ***Status area***

The lower right area of the window is the status area, which displays the current status of your editing session (for example, edit mode or input mode), and the number of files you are editing.

**z/OS analogy:** In z/OS, the ISPF editor has no status line of this type.

## **XEDIT and full screen CMS**

If you invoke XEDIT from full screen CMS, the way you see messages that other users send you is not the same as when full-screen CMS is off.

- ▶ When full screen CMS is off, the message appears on a cleared screen with a HOLDING status displayed at the bottom. You can clear your screen to return to the XEDIT screen.
- ▶ If full-screen CMS is on, any message you receive appears in the message window, which automatically opens on top of your XEDIT window.

To scroll forward in the message window, type f (forward) in one of the border corners (indicated by plus (+) signs) and press Enter.



Continue to type `f` until you have seen all the information in the message window. When there is no more information to display, the window is automatically removed from your screen.

## Data manipulation with prefix subcommands

After you enter the XEDIT command, you are in *edit mode*. You must be in edit mode to enter XEDIT subcommands. You can enter data into the file using *input mode* or power typing mode, which are discussed in the following sections.

If you are editing an existing file, place the cursor in the file area and type to replace the underlying text. As previously mentioned, XEDIT refers to its *shortcuts* as prefix subcommands. Prefix subcommands are one- or two-character commands that perform basic editing tasks on a particular line.

You enter prefix subcommands by typing over any position of the five-character prefix area on one or more lines. When you press Enter, all prefix subcommands that have been typed in the window are executed.

**z/OS analogy:** XEDIT prefix subcommands are similar in function to *line commands* in ISPF editor.

### Setting the current line

Many subcommands begin their operations starting with the current line. For example, the INPUT subcommand provides space for you to enter data after the current line. You have already seen the INPUT subcommand that inserts lines after the Top of File line.

You can type the forward slash (/) prefix subcommand in the prefix area of any line on the screen. When you press Enter, that line becomes the current line. Then, if you enter an INPUT subcommand, the new lines entered in input mode are inserted between the current line and the line that follows it.

### Adding lines

To add a line, type the single character A (add) or the character I (insert) in the prefix area to append blank lines. When you press Enter, a blank line is immediately inserted following the line containing the A, for example. A number can precede or follow the A to indicate adding more than one line. For example, A5 adds five blank lines. Valid ways to type the A prefix subcommand are:

====A	Adds one blank line after this line.
a====	Adds one blank line after this line.
10a==	Adds ten blank lines after this line.
===A5	Adds five blank lines after this line.

You then type information in the added lines. If you do not type information the blank lines remain in the file throughout the editing session and after the file is written to disk or directory.

**z/OS analogy:** In ISPF EDIT, you typically use the I(nsert) line command.

### ***Deleting lines***

To delete a line, enter the single character D in the prefix area of a line. A number can precede or follow the D to indicate deleting more than one line.

To delete a group of consecutive lines (that is, a block of lines) enter the double character DD in the prefix area of both the first and last lines to be deleted. By using this method, you do not have to count the number of lines to be deleted; see Example 2-22.

*Example 2-22 The consecutive line delete functionality*

---

```
==dd= This is the first line I want to remove.
===== This is the second.
===== This is the third.
===== This is the fourth.
===dd This is the fifth.
```

---

When you press Enter, the block of lines is deleted. The first and last lines of the block do not have to be in the same window; you can scroll the window before entering the second DD.

After you type DD and press Enter, the status area of the screen displays the message:

```
DD pending...
```

Use PF7 or PF8 to scroll backward or forward until you find the last line of the block, and then type DD in its prefix area. When you press Enter, the entire block of lines is deleted.

**z/OS analogy:** Functions are identical in both editors.

### ***Recovering deleted lines***

If you delete one or more lines, you can recover them anytime during an editing session by using the RECOVER subcommand. The following subcommand returns lines deleted in an editing session:

```
RECOVER n
```

The *n* represents the number of lines you want to recover. Recovered lines are inserted starting at the current line. The last lines deleted are the first lines recovered.

If the lines were deleted from different places in the file, you put them back where they belong by using the M (move) prefix subcommand. See “Moving lines” on page 84 for more information about this subcommand. To recover all lines that you deleted during an editing session, enter:

```
====> recover
```

In the previous example of the A and D prefix subcommands, six lines were deleted. To recover only the last two lines, use the following command:

```
====> recover 2
```

**z/OS analogy:** This is similar to using the RECOVERY ON command in the ISPF editor and typing UNDO, provided you have pressed Enter between each editing step you want to recover.

### ***Adding indented lines***

To continuously add lines of indented text, type the characters SI in the prefix area. After you press Enter, a line is added directly after the line that contains SI. The cursor is positioned at the same column where the text on the previous line begins, enabling you to more easily enter indented text.

If you do not want to add more lines, press Enter one more time without typing anything on the new line. To add a blank line in a file while using SI, make at least one change (such as pressing the spacebar once) on the line that contains the dotted line in the prefix area:

```
. . . . .
```

Note that simply using the cursor position keys to move the cursor over a line does *not* change the line.

You can leave the line you are adding and make corrections elsewhere in the file if you type something on the new line first. When you press Enter while the cursor is away from the new line, another new line is added following the last line that was added. SI is canceled only if you press Enter and have not typed text on the new line.

### ***Duplicating lines***

To duplicate a line, enter a double quotation mark (") in the prefix area of a line. A number can precede or follow the double quotation mark to duplicate the line more than one time; see Example 2-23 on page 84.

### Example 2-23 Inserting three duplicate lines

---

```
=3"= I want three more copies of this line.  
==== They will appear before this line.
```

---

When you press Enter, the file displays output similar to Example 2-24.

### Example 2-24 Output from inserting three duplicate lines

---

```
==== I want three more copies of this line.  
==== I want three more copies of this line.  
==== I want three more copies of this line.  
==== I want three more copies of this line.  
==== They will appear before this line.
```

---

To duplicate a block of lines, either one time or a specified number of times, type two double quotation marks (") in the *first* and *last* lines of the block. A number can precede or follow the first double quotations (for example, 5") to duplicate the block more than one time.

When you type one double quotation mark (") and press Enter, the status area of the screen displays the following status, allowing you to scroll the window before completing the block and pressing Enter:

```
" pending...
```

**z/OS analogy:** In z/OS, this is similar to using the **R n** (repeat) line command in ISPF editor.

### **Moving lines**

To move one line, enter the single character M (move) in the prefix area of the line to move. Indicate its destination by entering either the character F (following) or P (preceding) in the prefix area of another line. After you press Enter, the line containing the M is removed from its original location and is inserted in either immediately following the line containing the F, or immediately preceding the line containing the P, as appropriate.

A number can precede or follow the M to indicate moving more than one line (for example, 5M or M5) in the prefix area. The line to move and the destination line can be on different screens.

After you enter M, F, or P, the status area of the screen displays a Pending status. This pending status allows you to scroll the screen before entering the other prefix subcommand.

To move a block of lines, enter the double character MM in the prefix area of both the *first* and *last* lines to be moved. The first and last lines to be moved, and the destination line, can all be on different screens. You can use PF selections to scroll the screen before pressing Enter.

**z/OS analogy:** In z/OS (ISPF editor), the M(ove) command is identical, but line command A(fter) is used instead of F(ollowing), and B(efore) instead of P(receding).

### ***Copying lines***

The procedure for copying lines is the same as for moving lines, except that you enter a C or CC prefix subcommand instead of M or MM. The copy operation leaves the original lines in place but makes a copy at the destination line, which is indicated by F or P.

**z/OS analogy:** In z/OS (ISPF editor), the C(opy) command is identical, with the same exceptions as stated for the M(ove) command previously

### ***Canceling prefix subcommands***

If you entered one or more prefix subcommands that created a pending status, you can cancel all of them by entering the following subcommand on the command line:

```
====> reset
```

After you press Enter, all prefix subcommands disappear from the display and the prefix areas are restored with equal signs, numbers, or blank characters, depending on your particular XEDIT configuration.

If you have typed any prefix subcommands (even those that do not cause a pending status) but have not yet pressed Enter, you can clear your screen to remove them. If you have only typed a few characters, it is also sufficient to simply type over them with blank characters.

### ***Moving through a file***

XEDIT lets you move backward, forward, up, down, and to the top and bottom in a file. You have already seen that the PF7 and PF8 selections are set to the BACKWARD and FORWARD subcommands, which scroll one full window backward or forward. You may also enter the BACKWARD and FORWARD subcommands in the command line. The format of these subcommands is:

```
BAckwardn  
FOrwardn
```

Here *n* is the number of window displays to scroll. This is like pressing PF7 or PF8 *n* times. If you omit *n*, the editor scrolls one window backward or forward.

If you enter a BACKWARD subcommand when the current line is the Top of File line, the editor wraps around the file, making the last line of the file the new current line. Similarly, if you enter a FORWARD subcommand when the current line is the End of File line, the editor makes the first line of the file the new current line.

Suppose the file is many screens long and the current screen display is somewhere in the middle of the file. To return to the beginning of the file, you could enter multiple BACKWARD subcommands, or you can enter the TOP subcommand.

The TOP subcommand makes the Top of File line the new current line. Enter the TOP subcommand as shown:

```
====> top
```

The BOTTOM subcommand makes the last line of the file the new current line. Enter the BOTTOM subcommand as shown:

```
====> bottom
```

These subcommands are useful when you want to insert new lines either at the beginning or end of a file.

Suppose that you want to move the file up or down a few lines instead of a whole window. Use the DOWN subcommand to advance the line pointer one or more lines toward the end of a file. The line pointed to becomes the new current line. For example, the following command causes the fifth line down from the current line to be the new current line:

```
====> down 5
```

If you omit the number, then 1 (one line) is assumed. The UP subcommand moves the line pointer toward the beginning of the file. The line pointed to becomes the new current line. For example, the following command causes the fifth line up from the current line to be the new current line.

```
====> up 5
```

Again, if you omit the number, then 1 (one line) is assumed.

**z/OS analogy:** In z/OS (ISPF editor), these commands are identical.

## Searching within a file

Searching for a particular word or phrase is a very important part of text editing on any platform, and is especially important when using CMS to edit various configuration files. When using XEDIT, you can search by using the forward slash (/) on the command line, as shown:

```
====> /target_search_string
```

After pressing Enter, XEDIT moves to the first line it finds that matches your search phrase. XEDIT searches in the direction of the current line toward the end of the file. To move to the next occurrence, reenter the command:

```
====> /target_search_string
```

A more convenient solution is to prefix the search command with the ampersand (&) character:

```
====> &/target_search_string
```

Even easier is to enter equals (=) on the command line.

After pressing Enter, XEDIT moves to the first line it finds that matches your search phrase. Each time you press Enter again, XEDIT moves to the next match in the file.

This can be a very powerful way to move through files, but you can also search in reverse. The search is performed from the current line moving toward the top of the file. To search in reverse, prefix the search command with the minus sign (-), for example:

```
====> -/target (reverse search)
```

In some cases highlighting all occurrences of a phrase within a file can be useful. To accomplish this task, XEDIT provides the ALL command:

```
====> all /target
```

From the XEDIT command line, the ALL command lists all lines that contain instances of the target search phrase. To return to normal editing mode, issue the ALL command with no search phrase as shown:

```
====> all
```

**z/OS analogy:** In z/OS, this is similar to the F 'txt' (Find) primary command of ISPF editor.

**Note:** When using the ALL command or the search (/) command, you can set your current line to be one of the lines of output. This enables you to exit the search results and to directly edit the file at the location you want.

## Setting tabs

You might want to place information in specific columns. The PF4 key functions like a Tab key on a keyboard. Each time you press the PF4 key, the cursor is positioned at the next tab column, where you can enter data. The editor defines initial tab settings according to file type; you can display them by using the following subcommand:

```
====> query tabs
```

You can change these settings one or more times during an editing session with the SET TABS subcommand:

```
====> set tabs 10 20 30
```

Using the example, the first time you press PF4, the cursor moves to column 10 in the window. The second time, it moves to column 20, and so forth. You can use PF4 for tabbing in regular XEDIT input mode, but not all other advanced XEDIT modes. To change the tab settings, enter another SET TABS subcommand. To view the current tab settings before changing them, use the following subcommand:

```
====> modify tabs
```

This displays the current SET TABS subcommand in the command line; you can type over the numbers and press Enter to define new tabs.

## Inserting an external file

The GET subcommand inserts all or part of another file into the file you are editing, after the current line. A file that you *get* is not destroyed; a copy of that file is inserted.

Before you enter the GET subcommand, make the current line be the line *preceding* where you want to insert data. That way, the file will be inserted immediately under the current line.

To insert another file at the end of your file, use the BOTTOM subcommand to make the last line current. To insert another file somewhere in the middle of your file, use the UP or DOWN subcommands to make the desired line current.

**z/OS analogy:** This is similar to the COPY primary command of ISPF editor in z/OS.



### ***Inserting all of another file***

To insert an entire file into the file you are editing, use the command:

```
====> get filename filetype
```

For example, if you are editing FILE1 and want to insert all of FILE2 SCRIPT A at the end of FILE1, move the line pointer to the end of the file by issuing the following command:

```
====> bottom
```

With the line pointer at the end of the current file, import the entire external file by issuing the following command:

```
====> get file2 script
```

When the entire second file has been inserted, the editor displays the message:

```
EOF reached
```

### ***Inserting a portion of another file***

Sometimes, importing an entire file is unnecessary; instead, you might want only a portion of an external file. Use the GET command with additional optional arguments to insert a portion of another file.

The first additional parameter specifies the line number of the first line to import. The second additional parameter indicates the number of successive lines to insert. For example, to insert the first 10 lines of a second file:

```
====> get file2 data 1 10
```

### **Powertyping**

If you have to type a substantial amount of text continuously, without worrying about line numbers or word length, enter the command POWERINP. This places XEDIT in a mode called *power input* or *powertyping* mode. The shortest command abbreviation for POWERINP is POW.

When you are in powertyping mode, a **\*\*\* Power Typing\*\*\*** banner is displayed across the top of the window. Any time you want to leave powertyping mode, press the Enter key. Your text is formatted to fit the correct line width in a normal XEDIT session.

Combining the TOP or BOTTOM commands with POWERINP provides an easy method for prepending or appending to a file.

**z/OS analogy:** POW is similar to ISPF TextEntry (TE).

## Autosaving

To minimize the risk of losing your data, XEDIT provides the SET AUTOSAVE subcommand. This subcommand causes your file to be automatically written to disk after you have typed in or changed a certain number of lines. The syntax is:

```
SETAutosave n
```

The *n* specifies the number of typed-in or changed lines. For example, to write the file to disk or SFS directory every time you have changed 10 lines, enter:

```
====> set autosave 10
```

The number of alterations you have made to your file since the last AUTOSAVE is displayed as the alteration count (Alt=*n*) in the file identification line. When the alteration count is equal to the AUTOSAVE setting, and the file contains at least one record, the file is saved on disk or SFS directory and the alteration count is reset to zero (0).

You can enter the SET AUTOSAVE subcommand at any time during an editing session, but good practice would be to enter it right after you enter an XEDIT command to create a new file or to call an existing file from disk or SFS directory.

When a file is automatically saved, it is written to a new file that has a number for a file name is a number and that has a file type of AUTOSAVE. If the system malfunctions during an editing session, you can recover all changes made up to the time of the last automatic save.

To do this, replace the original file with the AUTOSAVE file by using the CMS COPYFILE command with the REPLACE option. If you enter a SET AUTOSAVE subcommand while you are creating a new file or revising an existing file, and then enter a QUIT subcommand, the new or revised file is not saved, but the AUTOSAVE file is available from disk.

**z/OS analogy:** This feature is similar to the RECOVERY ON command in the ISPF editor, except you cannot set the number of lines between each save. Pressing Enter or a PF key causes editing changes to be saved in a separate data set. If the editing session is terminated, you are prompted to recover the next time you edit the particular data set.

## Ending an editing session

You can end an editing session by using FILE or QUIT. When you use the XEDIT command to create a new file, the file is created in virtual storage. When you make changes to an existing file, those changes are made to a copy of the file that is brought into virtual storage (when the XEDIT command is entered).

However, virtual storage is temporary. To write a new or modified file to disk, enter the following subcommand:

```
====> file
```

When you use the FILE subcommand, the file is written to disk or directory and control is returned to CMS. You must use FFILE to save an empty file.

The QUIT subcommand ends an editing session and leaves the permanent copy of the file intact on the disk or directory. You can execute the QUIT subcommand either by selecting PF3 or by entering quit on the command line:

```
====> quit
```

Use the QUIT subcommand to quit XEDIT without saving changes to the file. This method of exiting XEDIT can be useful when you edit a file just to examine it but not change its contents, or if you have made an error when altering a file.

If the file is new and you have not input any data, the file is not written to disk. If a file is new or has been changed, the following warning message prevents you from inadvertently using QUIT instead of FILE:

```
File has been changed; type QQUIT to quit anyway
```

If you really do not want to save the file, enter QQUIT (abbreviated as QQ):

```
====> qquit
```

**z/OS analogy (z/OS/ISPF editor analogy):** The primary command CAN(ce)l is identical to exiting without saving. The SAVE command saves the data set or member regardless of whether it has changed.

An EDIT profile value of AUTOSAVE ON in ISPF implies that exiting the editor using PF3 would save the data set or member if it has been modified. If AUTOSAVE is set to NO, the editor prompts you to enter SAVE or CANCEL (this is very similar to using the XEDIT command).

## Customizing XEDIT

You can improve the XEDIT interface by creating a PROFILE XEDIT file on your A disk. XEDIT starts with the basic requirements of any data editing program (that is, it should allow you to add, delete, or change records in a file interactively from your screen). It also provides a significant range of additional and more specialized functions. Several advanced features include:

- ▶ Sophisticated data location commands
- ▶ Program controllable changes
- ▶ Display layout *tailoring*
- ▶ Selective data display

- ▶ Multiple files handled simultaneously
- ▶ Multiple logical displays per physical display

Recognizing the variety of different users who will need an editor, and their different expectations and requirements, XEDIT allows each user to define how file data should be displayed and how commands should take effect. Discussing these advanced features, and many more, are beyond the scope of this book.

A sample PROFILE XEDIT is shown in Example 2-25.

*Example 2-25 Sample PROFILE XEDIT A with basic XEDIT customization*

---

```

* * * Top of File * * *
/*****/
/* Sample PROFILE XEDIT */
/*****/

/* Set up function keys to do something useful */
'SET PF01 HELP MENU' /* XEDIT help */
'SET PF02 SOS LINEADD' /* Add a line at cursor position */
'SET PF03 QUIT' /* Quit XEDIT */
'SET PF07 BACKWARD' /* Scroll backward */
'SET PF08 FORWARD' /* Scroll forward */
'SET PF09 =' /* Re-execute last subcommand entered */
'SET PF10 RIGHT 10' /* Scroll document to right 10 columns */
'SET PF11 LEFT 10' /* Scroll document to left 10 columns */
'SET PF12 ?' /* Retrieve last command issued. */

/* Set up colors */
'SET COLOR PREFIX BLUE'
'SET COLOR ARROW WHITE'
'SET COLOR FILEAREA GREEN'

/* Set up display of editing window */
'SET NUM ON' /* Show line numbers */
'SET CMDLINE BOTTOM' /* Command line at bottom of screen */
'SET SCALE OFF' /* No "scale" bar across window */
'SET NULLS ON' /* Allows you to insert text in middle of a line */
'SET CASE M I' /* Allows uppercase and lowercase characters */
'SET CURLINE ON 3' /* Current line is always the 3rd visible line. */
'SET FULLREAD ON' /* move cursor to any spot and char stays put */
'SET STAY ON' /* stay at loc of last find vs bottom of file */
* * * End of File * * *

```

---

Experiment with the various options in the configuration file. For example, saving the file to PROFILE XEDIT A in your CMS system puts the configuration overrides into production. Start by adding one line at a time as you determine what you want. The configuration shown in Example 2-25 might not meet your

requirements, but it is presented to illustrate the customization available to XEDIT users.

**z/OS analogy:** The ISPF EDIT profile works in a similar way.

**Tip:** The XEDIT PROFILE lets you customize XEDIT so it behaves more similarly to ISPF EDIT, if you prefer. The SYNONYM command is a good place to start. See *z/VM: XEDIT User's Guide*, SC24-6132 manual.

## Getting help with XEDIT

If you forget how to use a subcommand, or want to view information about subcommands not explained here, select PF1, which is set to the HELP MENU subcommand. The PF1 option lists all subcommands and macros available for the editor.

If PF1 does not display a help menu for XEDIT, you can manually enter the command HELP XEDIT MENU. Move the cursor to the desired subcommand and press Enter. The subcommand description appears in the window, replacing the Full-Screen Text Processing HELP Menu.

To return to the previous window, select PF3. To exit the HELP display and restore your file in the window, press PF4.

**z/OS analogy:** In the ISPF editor, using PF1 in the ISPF editor works in a similar way, but cannot be used to edit primary or line commands directly. Instead, they are presented in archaically organized panels.

Archived

# Introducing Linux on System z to z/OS system programmers

In this chapter, we give an overview of where Linux came from, where it is now, and where it is going. We also take a deeper look into Linux on System z and the benefits from it.

## Objectives

After completing this chapter, you should be able to:

- ▶ Discuss basic concepts of Linux
- ▶ Use basic skills to navigate in Linux
- ▶ Identify basic Linux commands

## 3.1 Overview of Linux

This section gives an overview of Linux and how it interacts with the System z. It looks at what comprises a distribution of Linux on System z, and highlights the major features of the most popular enterprise Linux editions for System z distribution.

### 3.1.1 History of Linux

In the simplest terms, Linux is an operating system. It was developed beginning in 1991 by a University of Helsinki student named Linus Torvalds (Linux stands for Linus UNIX). Linux itself is actually just the kernel; it implements multitasking and multiuser functionality, manages hardware, allocates memory, and enables applications to run.

Over the years, the Linux operating system has become a real and viable alternative for PC users, and corporate servers and users. Linux delivers the power and flexibility of a UNIX server or desktop. It also provides a set of utilities, Internet applications, and a fully functional desktop interface.

The Linux operating system has become a server platform for powerful Internet and many other applications. Linux is capable of running from a corporate Web, File Transfer Protocol (FTP), file and printer servers, to wide-area information server (WAIS) Web sites or even corporate database servers, with real-time clusters or high performance computing clusters.

Linux is a fully functional operating system similar to a UNIX system. It has many of the standard features of enterprise UNIX systems. Management of the command structure is enabled through a *shell*.

**z/OS analogy:** This shell is much like the ISPF shell (ishell). This is also similar to the z/OS TSO environment.

Enhanced graphical environments and desktops are also available.

The structure of Linux is organized on file systems that provide the interfaces and abstraction needed to work with data and files. Files are organized into directories with the disk hardware. Each directory can contain any number of subdirectories each holding files. This is a similar structure to classical PC and UNIX operating system file structures. Linux supports the majority of the existing file systems, either by having kernel built-in support or through kernel modules.



## 3.1.2 Components of Linux

Linux has three fundamental components:

- ▶ Kernel

This provides low-level system control and interfaces, program and hardware device management, and an abstraction layer for the user level.

- ▶ init

This is usually the main program executed after the kernel is loaded into memory. From init, you can execute different run levels on the user space, with different characteristics.

- ▶ Applications

Linux applications cover many categories. The list is ever-expanding as more companies embrace this technology. Through writing applications for Linux, development costs usually decrease, spawning new projects and increasing the number of titles overall. Across the many horizontal and vertical markets with a Linux presence, we can cite the following categories: office productivity, Internet-related, network and systems management, software development, video production, data management, accounting and finance, and publishing.

Linux has the same multi-user and multitasking capabilities as large UNIX operating systems. It provides the same level of system administration that you find on standard UNIX systems. Users can run multiple programs concurrently; it has separate levels for user space and kernel space. You can create user accounts for different users, and define their access rights to the files and system components. Installation of new devices and network connection and control is also provided as standard in the Linux operating system.

## 3.1.3 Linux on System z distributions

Supported Linux distributions for System z are currently available from two major Linux distributors: Novell's SUSE Linux Enterprise Server (SLES) and Red Hat Enterprise Linux (RHEL). Each distribution of Linux has its pros and cons.

Linux that supports the S/390® architecture has been generally available since early 2000 either from IBM developerWorks® or from the Linux distribution partners. All the current distributions (as of May 2008) are based on the Linux 2.6 kernel. Each distribution includes additional middleware and applications. The distribution also includes infrastructure services such as domain name server (DNS), Dynamic Host Configuration Protocol (DHCP), and Network File System (NFS) file servers, and packages such as the Apache Web server, Squid proxy server, Simple Mail Transfer Protocol (SMTP) mail server, and Samba Windows

networking server. These distributions also leverage the HiperSockets technology of the System z server to interconnect between different partitions.

The distributions that are available for System z are:

- ▶ Novell: SUSE Linux Enterprise Server (SLES) 10, Kernel 2.6.16 is available from:  
<http://www.novell.com/partners/ibm/mainframe/>
- ▶ Red Hat: Red Hat Enterprise Linux (RHEL) 5, Kernel 2.6.18 is available from:  
<http://www.redhat.com/rhel/server/mainframe/>
- ▶ Debian: Debian Etch, Kernel 2.6.18 is available from:  
<http://www.us.debian.org/ports/s390/>
- ▶ Build your own: download the kernel from:  
<http://www.kernel.org>

For more information about new hardware features available with latest kernel upgrades, see developerWorks navigation for Linux on System z at:

<http://oss.software.ibm.com/developerworks/opensource/linux390/index.shtml>

<http://www-03.ibm.com/systems/z/os/linux/>

### 31-bit and 64-bit options

Linux on System z solutions are available for 31-bit and 64-bit environments. The option availability depends on the System z model and the Linux distribution.

**Note:** The choice between the 31-bit and 64-bit addressing environments can depend on the application or middleware you are planning to use. Some software does not support 64-bit addressing mode and might not work properly.

The latest versions (SLES10 and RHEL5) of the distributions are 64-bits only. Older versions (SLES9, RHEL4) are available as 31 or 64-bits distributions.

The Linux 2.6 kernel has undergone substantial testing in 64-bit mode, and is intended for large-scale, highly-available systems. The IBM strategy is focused on middleware applications running on 64-bit platforms. Whenever possible, a 64-bit enterprise Linux distribution is recommended. The 64-bit kernel offers greater memory addressability, and provides greater flexibility for running Linux on System z. With the 64-bit kernel, you can run many small Linux images or fewer but larger Linux images in a given z/VM partition.

Applications that can benefit most from 64-bit addressing include:

- ▶ Databases
- ▶ Applications requiring access to large amounts of data
- ▶ Java applications

Although most middleware has been or will be ported to 64-bit, it is important to note that not all can benefit from the larger address space. In these cases, the middleware continues to operate in 31-bit addressing mode on a 64-bit Linux distribution using *compatibility mode*. For this reason 31-bit libraries are available on 64-bit distributions, as shown in Figure 3-1.

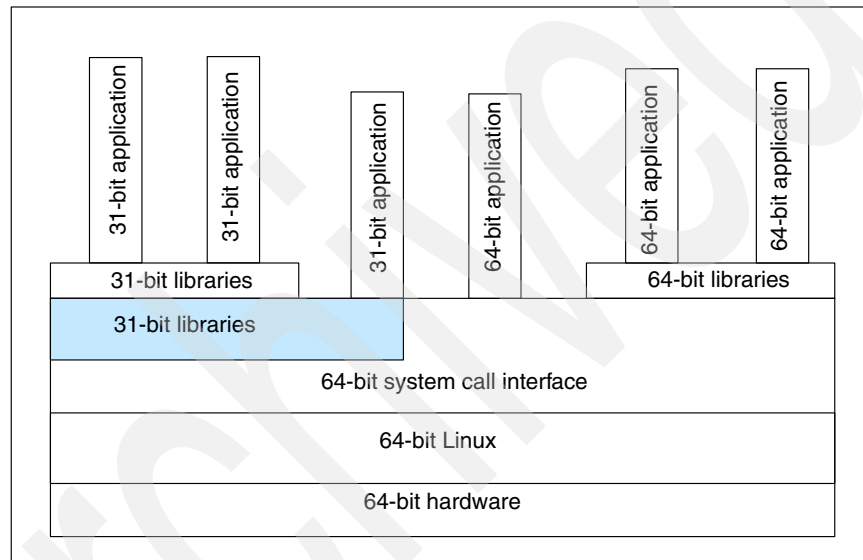

Figure 3-1 Compatibility mode system call emulation

### Integrated Facility for Linux (IFL)

An IFL is a processor reserved for Linux (or Linux under VM). The significance is that it cannot be used to run other operating systems, and its existence is not reflected in the system model number, MIPS rating, or other capacity ratings. The system model, MIPS, or other capacity rating method has significant implications for software costs. Adding an IFL does not affect the costs associated with your system MIPS, which permits the use of Linux without affecting other software costs.

**Note:** IFLs must be used by LPARs running Linux or /VM only. However they can be shared by multiple LPARs, provided that the LPARs are running Linux or z/VM.

IFL has the same functionality as a general purpose CP on the System z server. These include but are not limited to: Support for On/Off Capacity on Demand (On/Off CoD), Capacity for Planned Event (CPE), and Capacity BackUp (CBU) for emergency situations.

**Important:** Figure 3-2 shows how IFLs can be allocated in a LPAR for pre-z10; however, z10 might have IFLs and General CPUs in the same LPAR. So, in Figure 3-2, configuration A would be allowed in a z10 but not in pre-z10 models.

Figure 3-2 shows how IFLs can be allocated to LPARs

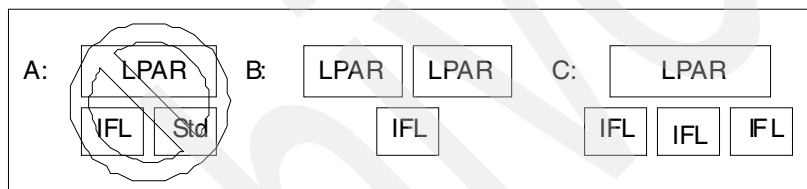

Figure 3-2 The relationship between IFLs and LPARs

For more details on IFLs, visit the IBM Web site at:

<http://www-03.ibm.com/systems/z/os/linux/solutions/ifl.html>

## 3.2 Getting started with Linux

This section discusses basic concepts of using your Linux server.

### 3.2.1 The file system and root user

The Linux file system is a hierarchy of files starting at the root directory.

## File system

Linux is made up of files and directories in a hierarchical structure. The Linux file system is divided into main directories:

- ▶ */home* — Stores home directories of all users. This is basically where users store any files they own: media, source code, desktop configuration files, and more. The home directory for the root user is sometimes referred to as the root directory.
- ▶ */bin* — Stores the executables (essential system programs). Commands to load kernel modules and access devices are usually placed here.
- ▶ */usr/bin* — Stores the system commands (the real warehouse for software)
- ▶ */usr/sbin* — Stores commands usually used to perform system administration tasks.
- ▶ */usr/local* — Is a second-level directory of Linux Filesystem Hierarchy Standard (FHS). Software that follows the FHS but you do not want to mix with other software on the first level (*/usr*) of the FHS is usually placed here. For example, an in-house software that you might be developing.
- ▶ */etc* — Stores the program default and system configuration files for the system and program default configuration files that can be shared by all users. Also stores the run-level configuration files.
- ▶ */var* — Stores logs, spool directories, database files, file servers files, and system lock files.
- ▶ */lib* — Stores program and shared libraries.
- ▶ */dev* — Stores device files: memory, disks, removable media devices (storage, multimedia) and any type of hardware.
- ▶ */proc* and */sys* — Stores system filesystems that contain real time data. These directories contain real-time data about the configuration of the hardware and running processes as Linux sees them: processor, ACPI parameters, processes, information of each running process (PID, I/O file descriptors), and kernel configuration.
- ▶ */opt* — Stores additional software. Usually, vendors applications are installed here.
- ▶ */tmp* — Stores temporary files. Its contents are usually deleted during boot time. Never place important files here.

## The root user

By default, the root user is the system administrator, which means no restrictions on root privileges. Because root has such authority, someone who is not completely knowledgeable of the system can cause damage. Logging in to root is recommended for administrative actions only. Although user root is equivalent to

IBMUSER in z/OS, it is more powerful because root has an access to everything by default. Root access cannot be restricted.

### 3.2.2 Basic starting steps

This section discusses basic commands, such navigating in the directories, viewing the contents of a directory or file, and creating directories.

**Important:** Linux commands and file names are case-sensitive. For example, the command `chmod` cannot be typed as `Chmod` or `CHMOD`.

**Tip:** Pressing the Tab key after you start typing a command or file name can complete the rest of the command or file name. Also, pressing Ctrl+R performs a search of all previous commands issued.

#### Getting help with Linux commands

Linux does not have a help menu as z/VM and z/OS do. Instead, Linux has a command called `man`, which displays the page of the command from the online reference manuals. This page includes: the name, synopsis of how it is used, description of how the command functions, and other details. To use the command, type:

```
man commandname
```

The `commandname` is the name of the command you want help with (see Example 3-1).

**Note:** You must know the name of the command you want to use to access its manual page.

To scroll through the file use the up and down arrow. To quit the file press Q.

*Example 3-1 The man command on the man command itself*

---

```
Inxken:/ # man man
NAME
    man - an interface to the on-line reference manuals

SYNOPSIS
    man [-c|-w|-tZHT device] [-adhu7V] [-i|-I] [-m
    system[,...]] [-L
    locale] [-p string] [-M path] [-P pager] [-r prompt] [-S
    list] [-e
    extension] [[section] page ...] ...
```

```
man -l [-7] [-tZHT device] [-p string] [-P pager] [-r prompt]
file ...
man -k [apropos options] regexp ...
man -f [whatis options] page ...
```

## DESCRIPTION

man is the system's manual pager. Each page argument given to man is normally the name of a program, utility or function. The manual page associated with each of these arguments is then found and displayed. A section, if provided, will direct man to look only in that section of the manual. The default action is to search in all of the available sections, following a pre-defined order and to show only the first page found, even if page exists in several sections.

The table below shows the section numbers of the manual followed by the types of pages they contain.

0	Header files (usually found in /usr/include)
1	Executable programs or shell commands
2	System calls (functions provided by the kernel)
3	Library calls (functions within program libraries)
4	Special files (usually found in /dev)
5	File formats and conventions eg /etc/passwd
6	Games
7	Miscellaneous (including macro packages and conventions), e.g. man(7), groff(7)
8	System administration commands (usually only for root)
9	Kernel routines [Non standard]

A manual page consists of several parts.

They may be labelled NAME, SYNOPSIS, DESCRIPTION, OPTIONS, FILES, SEE ALSO, BUGS, and AUTHOR.

---

## Navigating through the file system

The command for changing from one directory to another is **cd** (short for change directory). The proper use of the command is:

```
cd directoryname
```

The directoryname is the name of the directory to access (see Example 3-2 on page 104).

*Example 3-2 The cd (change directory) command*

---

```
lnxken:~ # cd Desktop/  
lnxken:~/Desktop #
```

---

With the **cd** command you have several options:

- cd .. This move you up one level in the directory tree (see Example 3-3).
- cd / This brings you to the root of the file system directory no matter which directory you are currently in (see Example 3-4).
- cd - This returns you to the previous directory you were in (see Example 3-5).

*Example 3-3 Changing to the parent directory: cd ..*

---

```
lnxken:/etc/init.d/rc3.d # cd ..  
lnxken:/etc/init.d #
```

---

*Example 3-4 Changing to the root of the file system directory: cd /*

---

```
lnxken:/etc/init.d/rc3.d # cd /  
lnxken:/ #
```

---

*Example 3-5 Changing to the previous directory: cd -*

---

```
lnxken:/ # cd -  
/etc/init.d/rc3.d  
lnxken:/etc/init.d/rc3.d #
```

---

## Displaying the contents of a directory

Now that you can change from one directory to the next, you want the ability to view the contents of the directories. To do this, use the **ls** command.

- ▶ To list the contents of the current directory, use the **ls** command without an option.
- ▶ To list the contents of another directory, type the **ls** command with an option:  
ls directoryname

The *directoryname* is the name of the directory whose contents you want to view. See Example 3-6.

*Example 3-6 Listing the current directory contents*

---

```
lnxken:/ # ls  
bin dev home lib64 media opt root srv tmp var  
boot etc lib lost+found mnt proc sbin sys usr
```



```
lnxken:/ # ls root/
.DCOPserver_lnxken_3 .gconf          .local          .vnc
.DCOPserver_lnxken__3 .gconfd         .mozilla       .wapi
.ICEauthority        .gnome2         .qt             Desktop
.Xauthority          .gnome2_private .skel
.bash_history        .gnupg          .suse_register.log bin
.exrc                .kde            .viminfo
lnxken:/ #
```

---

To list the contents with long details, type `ls -al` (see Example 3-7).

*Example 3-7 Listing all the current directory contents with details*

---

```
lnxken:/ # ls -al
total 92
drwxr-xr-x 21 root root 4096 May 19 13:58 .
drwxr-xr-x 21 root root 4096 May 19 13:58 ..
drwxr-xr-x  2 root root 4096 May 15 09:50 bin
drwxr-xr-x  4 root root 4096 May 15 09:52 boot
drwxr-xr-x  9 root root 2440 May 19 11:57 dev
drwxr-xr-x 75 root root 8192 May 19 11:58 etc
drwxr-xr-x  3 root root 4096 May 15 13:54 home
drwxr-xr-x  9 root root 4096 May 15 13:26 lib
drwxr-xr-x  5 root root 4096 May 15 13:25 lib64
drwx----- 2 root root 16384 May 15 09:43 lost+found
drwxr-xr-x  2 root root 4096 Jun 16 2006 media
drwxr-xr-x  2 root root 4096 Jun 16 2006 mnt
drwxr-xr-x  4 root root 4096 May 15 09:48 opt
dr-xr-xr-x 57 root root    0 May 19 11:57 proc
drwx----- 16 root root 4096 May 19 13:58 root
drwxr-xr-x  3 root root 8192 May 15 09:51 sbin
drwxr-xr-x  4 root root 4096 May 15 09:43 srv
drwxr-xr-x 10 root root    0 May 19 11:57 sys
drwxrwxrwt 10 root root 4096 May 19 15:15 tmp
drwxr-xr-x 13 root root 4096 May 15 09:50 usr
drwxr-xr-x 14 root root 4096 May 15 09:46 var
lnxken:/ #
```

---

The default rules for the color of contents are as follows:

- ▶ directories = blue
- ▶ files = white
- ▶ executable files = green
- ▶ links = light blue

- ▶ devices = yellow
- ▶ sockets = pink

## Creating a directory

To create (make) a directory in your current directory, use the **mkdir** command and provide a directory name (also shown in Example 3-8):

```
mkdir directoryname
```

### *Example 3-8 Making a directory*

---

```
lnxken:~/Desktop # mkdir MyMusic
lnxken:~/Desktop # ls -al
total 48
drwx----- 5 root root 4096 May 19 15:56 .
drwx----- 16 root root 4096 May 19 13:58 ..
-rw-r--r--  1 root root   69 May 15 13:48 .directory
-rw-r--r--  1 root root 1043 May 15 13:48 MozillaFirefox.desktop
drwxr-xr-x  2 root root 4096 May 19 15:56 MyMusic
-rw-r--r--  1 root root 1797 May 15 13:48 Network.desktop
-rw-r--r--  1 root root 2483 May 15 13:48 Printer.desktop
-rw-r--r--  1 root root  887 May 15 13:48 myComputer.desktop
-rw-r--r--  1 root root 5065 May 15 13:48 trash.desktop
lnxken:~/Desktop #
```

---

To set permissions for the directory, type the following command, where *XXX* is the permission code of the directory:

```
mkdir -mXXX directoryname
```

See Example 3-9 (details about permission codes are in section 3.2.3, “File permissions” on page 110).

### *Example 3-9 Making a directory with certain file permissions*

---

```
lnxken:~/Desktop # mkdir -m777 MyPictures
lnxken:~/Desktop # ls -al
total 52
drwx----- 6 root root 4096 May 19 16:06 .
drwx----- 16 root root 4096 May 19 13:58 ..
-rw-r--r--  1 root root   69 May 15 13:48 .directory
-rw-r--r--  1 root root 1043 May 15 13:48 MozillaFirefox.desktop
drwxr-xr-x  2 root root 4096 May 19 15:56 MyMusic
drwxrwxrwx  2 root root 4096 May 19 16:06 MyPictures
-rw-r--r--  1 root root 1797 May 15 13:48 Network.desktop
-rw-r--r--  1 root root 2483 May 15 13:48 Printer.desktop
-rw-r--r--  1 root root  887 May 15 13:48 myComputer.desktop
```

---

```
-rw-r--r-- 1 root root 5065 May 15 13:48 trash.desktop  
lnxken:~/Desktop #
```

---

## Moving files

To move a file, use the command **mv source destination**, where *source* is the location and file name of the file to be moved, and *destination* is the new location of the file (see Example 3-10).

*Example 3-10 Moving a file from one location to another*

---

```
lnxken:~/Desktop/MyDocs # ls -al  
total 20  
drwxr-xr-x 4 root root 4096 May 19 17:15 .  
drwx----- 3 root root 4096 May 19 17:12 ..  
drwxr-xr-x 2 root root 4096 May 19 16:29 MyMusic  
drwxrwxrwx 2 root root 4096 May 19 17:13 MyPictures  
-rw-r--r-- 1 root root 83 May 19 17:15 smilepic  
lnxken:~/Desktop/MyDocs # mv smilepic MyPictures/  
lnxken:~/Desktop/MyDocs # ls -al  
total 16  
drwxr-xr-x 4 root root 4096 May 19 17:16 .  
drwx----- 3 root root 4096 May 19 17:12 ..  
drwxr-xr-x 2 root root 4096 May 19 16:29 MyMusic  
drwxrwxrwx 2 root root 4096 May 19 17:16 MyPictures  
lnxken:~/Desktop/MyDocs # ls -al MyPictures/  
total 12  
drwxrwxrwx 2 root root 4096 May 19 17:16 .  
drwxr-xr-x 4 root root 4096 May 19 17:16 ..  
-rw-r--r-- 1 root root 83 May 19 17:15 smilepic  
lnxken:~/Desktop/MyDocs #
```

---

**Note:** To rename a file without changing its location, use the **mv** command with the old and new filenames as arguments:

```
mv oldname newname
```

This renames the file *oldname* to *newname*, without changing its location.

## Copying files

To copy a file, use the command **cp source destination**, where *source* is the location and file name of the file to be copied, and *destination* is the new location and file name (see Example 3-11 on page 108 and Example 3-12 on page 108).

*Example 3-11 Copying a file or make a backup*

---

```
lnxken:~/Desktop/MyDocs/MyPictures # cp smilepic smilepic.bak
lnxken:~/Desktop/MyDocs/MyPictures # ls -al
total 16
drwxrwxrwx 2 root root 4096 May 19 17:18 .
drwxr-xr-x 4 root root 4096 May 19 17:16 ..
-rw-r--r-- 1 root root 83 May 19 17:15 smilepic
-rw-r--r-- 1 root root 83 May 19 17:18 smilepic.bak
lnxken:~/Desktop/MyDocs/MyPictures #
```

---

*Example 3-12 Copying a file from one location to another location*

---

```
lnxken:~/Desktop/MyDocs/MyPictures # cp smilepic.bak
/root/Desktop/MyDocs/
lnxken:~/Desktop/MyDocs/MyPictures # ls -al ..
total 20
drwxr-xr-x 4 root root 4096 May 19 17:21 .
drwx----- 3 root root 4096 May 19 17:12 ..
drwxr-xr-x 2 root root 4096 May 19 16:29 MyMusic
drwxrwxrwx 2 root root 4096 May 19 17:20 MyPictures
-rw-r--r-- 1 root root 83 May 19 17:21 smilepic.bak
lnxken:~/Desktop/MyDocs/MyPictures #
```

---

## Deleting files or directories

To delete (remove) a file, use the command `rm filename`, where *filename* is the name of the file to be removed (see Example 3-13). To remove a directory, type the command `rm -Rf filename`, where `-R` means to recursively delete everything in that directory and `-f` means force the action to happen (see Example 3-14).

*Example 3-13 Removing a file*

---

```
lnxken:~/Desktop/MyDocs # rm smilepic.bak
lnxken:~/Desktop/MyDocs # ls -al
total 16
drwxr-xr-x 4 root root 4096 May 19 17:21 .
drwx----- 3 root root 4096 May 19 17:12 ..
drwxr-xr-x 2 root root 4096 May 19 16:29 MyMusic
drwxrwxrwx 2 root root 4096 May 19 17:20 MyPictures
lnxken:~/Desktop/MyDocs #
```

---

*Example 3-14 Removing a directory*

---

```
lnxken:~/Desktop/MyDocs # rm -Rf MyMusic/
lnxken:~/Desktop/MyDocs # ls -al
```

```
total 12
drwxr-xr-x 3 root root 4096 May 19 17:22 .
drwx----- 3 root root 4096 May 19 17:12 ..
drwxrwxrwx 2 root root 4096 May 19 17:20 MyPictures
lnxken:~/Desktop/MyDocs #
```

---

## Viewing the contents of a file

To view the contents of a file, use one of the following three commands:

- |                      |  |
|----------------------|--|
| <b>less filename</b> | Displays the file one page at a time; allows you to scroll up, down, right, and left.  |
| <b>more filename</b> | Displays the file one page at a time; allows you to scroll <i>only</i> down through the file   |
| <b>cat filename</b>  | Displays the entire file at once and goes back to the shell. The command <b>cat</b> can also be used to concatenate several files into one file. |

## Customizing commands

To customize command names, use the **alias** command. It provides a way to help you remember a command that is difficult to remember. You may also use it to create short cuts for commands. Example 3-15 demonstrates using the **alias** command to rename the **rm** command to something easier to remember, in this example, the **erase** command.

### Example 3-15 The **alias** command

---

```
lnxken:~/Desktop/MyDocs/MyPictures # alias erase=rm
lnxken:~/Desktop/MyDocs/MyPictures # ls -l
total 8
-rw-rw-rw- 1 root root 83 May 19 17:20 smilepic
-rw-r--r-- 1 root root 83 May 19 17:18 smilepic.bak
lnxken:~/Desktop/MyDocs/MyPictures # erase smilepic
lnxken:~/Desktop/MyDocs/MyPictures # ls -l
total 4
-rw-r--r-- 1 root root 83 May 19 17:18 smilepic.bak
lnxken:~/Desktop/MyDocs/MyPictures #
```

---

## Summary of Linux commands

Table 3-1 on page 110 lists basic commands to help you get started in Linux. For more commands and help with Linux, see the following Web sites:

<http://www.unixguide.net/linux/linuxshortcuts.shtml>  
[http://blog.linuxpages.com/ultimate\\_linux.html](http://blog.linuxpages.com/ultimate_linux.html)

Table 3-1 Summary of basic Linux commands

Command	Description	Example
cd	Changes directory	cd directoryname
ls	Lists a directory contents	ls directoryname
mv	Moves a file or directory	mv file newlocation
cp	Copies a file or directory	cp oldfile newfile
mkdir	Makes a new directory	mkdir newdirectory
rm	Removes a file or directory	rm filename
more	Displays file contents with limited navigation abilities	more filename
less	Displays file contents with full navigation abilities	less filename
cat	Displays file and can join files together	cat filename
man	Gives help on a command	man commandname
alias	Gives alias name to a command	alias aliasname=command
pwd	Displays working directory	pwd
who	Lists who currently logged on	who
whoami	Reports what user you are currently logged on as	whoami
ps	Lists all process currently running	ps

### 3.2.3 File permissions

In Linux, every directory and file has a set of permissions, which assigns users, groups and others the permission to read, write, and execute other user's files based on authorization.

The three ways of restricting file access in Linux are:

- ▶ Read (r): The file or directory can only be read.
- ▶ Write (w): The file or directory can have changes made.
- ▶ Execute (x): The file or directory can be executed.

Three sets of users are defined for the three types of file access:

- ▶ User (u): the person who is the owner of the file or directory
- ▶ Group (g): the user or users who are members of the group to which the file or directory is assigned
- ▶ Others (o): all users who are not the owner or in the group of the file or directory

The first character in the file permissions list indicates the type of file (see Table 3-2):

Table 3-2 File types

Type of File	Character
regular file	-
directory	d
symbolic link	l
named pipe	p
socket	s
character device file	c
blocked device file	b

The file permission is listed by using the `ls -l` command. An explanation of the file permission's layout and positioning is shown in Figure 3-3 and Figure 3-4.

Figure 3-3 File permission layout

Position	1	2	3	4	5	6	7	8	9	10
Layout	File	User			Group			Other		
Character	Type	Read	Write	Execute	Read	Write	Execute	Read	Write	Execute
Example	d	r	w	x	r	w	-	r	-	-

The layout of the `ls -l` command is shown in Figure 3-4.

Figure 3-4 Layout of the `ls -l` command

Type & Permission	# of Links	File's Owner	File's Group	Size in Bytes	Last modification date	filename
-rwxrw-rw-	1	Ken	Student	652	May 20 10:05	smilepic

In Example 3-16 the file `smilepic` shows `-rwxrw-rw-`, which indicates that: the owner has read, write, and execute access; the group has read and write access; and other users have read and write access.

*Example 3-16 Sample of file permissions*

---

```
lnxken:~/Desktop/MyDocs/MyPictures # ls -l
total 8
-rwxrw-rw- 1 ken student 83 May 19 17:20 smilepic
-rw-r--r-- 1 ken student 83 May 19 17:18 smilepic.bak
lnxken:~/Desktop/MyDocs/MyPictures #
```

---

**Note:** Although a user might have permission for a certain action for a file, that user still might not have access to that action based on the permission of the directory in which the file is located.

## Changing permissions

Users can change their own file permissions but cannot change permissions of other users. Note that the `root` user ID does have the power to change permissions on all files.

The Linux command to change a file permission is `chmod`, which can be used in two ways: with the octal system or with symbols.

### Octal system

The octal system uses numbers to change the permission of the file. After a user understands the octal system, using it is generally faster than using symbols. Table 3-3 lists the combinations of octal numbers for giving permissions.

Table 3-3 Permission combinations

Value	Permission
1	---
2	--X
3	-wX
4	r--
5	r-X
6	rw-
7	rwx



Example 3-17 shows the **chmod** command using an octal number to assign permissions to a file.

*Example 3-17 Octal system with the chmod command*

---

```
lnxken:~/Desktop/MyDocs/MyPictures # ls -l
total 8
-rw-rw-r-- 1 root root 83 May 19 17:20 smilepic
-rw-r--r-- 1 root root 83 May 19 17:18 smilepic.bak
lnxken:~/Desktop/MyDocs/MyPictures # chmod 750 smilepic
lnxken:~/Desktop/MyDocs/MyPictures # ls -l
total 8
-rwxr-x--- 1 root root 83 May 19 17:20 smilepic
-rw-r--r-- 1 root root 83 May 19 17:18 smilepic.bak
lnxken:~/Desktop/MyDocs/MyPictures #
```

---

The examples changes the file permissions from `-rw-rw-r--` to `-rwxr-x---` by using the following command:

```
chmod 750 smilepic
```

The number 7 in the first position indicates that we want to change the owner's access from read and write access to read, write, and execute access. The number 5 in the second position indicates that we want to change the group's access from read and write to read and execute (no write access). The number 0 in the third permission indicates that we want to change the access of other users from read-only to no access at all.

### **Symbols**

Symbols used with the **chmod** command can have four values:

- ▶ The type of user:
  - u for user
  - g for group
  - o for others
- ▶ The type of change being made:
  - - for remove permission
  - + for add permission
  - = for defining permission
- ▶ The type of access to be applied:
  - r for read
  - w for write
  - x for execute
- ▶ The file or directory to which the change applies

Example 3-18 demonstrates the **chmod** command using symbols.

*Example 3-18 Symbol mode for the chmod command*

---

```
lnxken:~/Desktop/MyDocs/MyPictures # ls -l
total 8
-rw-r-x--- 1 root root 83 May 19 17:20 smilepic
-rw-r--r-- 1 root root 83 May 19 17:18 smilepic.bak
lnxken:~/Desktop/MyDocs/MyPictures # chmod g-x smilepic
lnxken:~/Desktop/MyDocs/MyPictures # ls -l
total 8
-rw-r----- 1 root root 83 May 19 17:20 smilepic
-rw-r--r-- 1 root root 83 May 19 17:18 smilepic.bak
lnxken:~/Desktop/MyDocs/MyPictures # chmod go+rw smilepic
lnxken:~/Desktop/MyDocs/MyPictures # ls -l
total 8
-rw-rw-rw- 1 root root 83 May 19 17:20 smilepic
-rw-r--r-- 1 root root 83 May 19 17:18 smilepic.bak
lnxken:~/Desktop/MyDocs/MyPictures #
```

---

### 3.2.4 Job control

Because Linux is a multitasking operating system, a user can run multiple jobs or processes at one time. To view a list of jobs running, use the **jobs** command. To also see the process number of each running job, use the **jobs -p** command, which gives the process number of each job running.

To see a list of all running processes you own, use the **ps** command. To see all processes running, use the **ps -e** command.

**Note:** The words job and process can be used interchangeably.

#### Run a job in the background

Although most commands execute quickly, if you know that a command takes more time, you can temporarily suspend the job to the background by typing:

**CTRL -z**

You may now execute other commands. To return to your original job you suspended to the background, type one of the following commands:

- |                      |  |
|----------------------|--|
| <b>fg %jobname</b>   | Brings the process to the foreground (execution), but holds the shell. |
| <b>bg %jobnumber</b> | Sends the process to the background.                                   |

## End a job

If you want to cancel a job, type one of the following `kill` commands:

```
kill jobnumber  
kill jobname
```

With the `kill` command, you can specify a number, which is a level that signals how you want to kill the process. The format is:

```
kill -n jobnumber/jobname
```

The `n` is the level number. Number 9, which is the highest level, ends the job immediately. Number 15 allows the job to clean up before terminating. Use the `man` command for more information about the `kill` command.

## 3.2.5 Linux vi editor

The Linux `vi` editor is a text editing utility included in every Linux distribution. This section introduces the `vi` editor by describing the three operating modes of `vi` and how to switch from one mode to another, and describes basic `vi` commands.

### Modes of operation

The `vi` editor operates in three modes:

- ▶ Command mode: You enter commands in this mode.
- ▶ Insert mode: You insert characters at the cursor position.
- ▶ Replace mode: You overwrite the character at the cursor position.

To switch from one mode to another:

- ▶ From command mode to insert mode, press one of these single keys but *do not* press Enter:  
`i`, `I`, `a`, `A`, `o`, `O`

**Note:** Typing a single character immediately brings `vi` to the insert mode. Do not make the mistake of pressing Enter after that. If you do, it will be treated as input in the Insert mode.

- ▶ From command mode to replace mode, press `R` (again, without Enter).
- ▶ From replace or insert mode to command mode, press `Esc`.

Figure 3-5 illustrates the three modes in which vi operates and the keys you must press to go from one mode to the other.

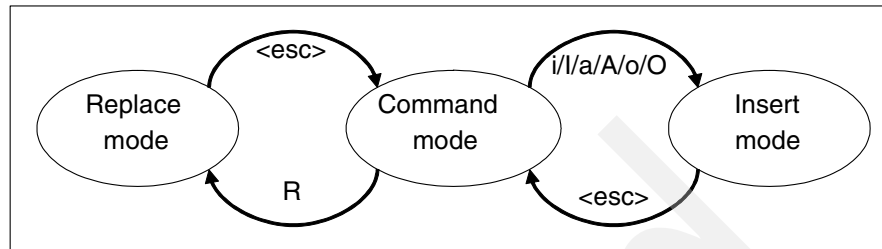

Figure 3-5 vi operating modes

The bottom left corner of the vi window indicates which operating mode you are using (the area is blank if you are in command mode):

- ▶ -- REPLACE --
- ▶ -- INSERT --

Normally, vi starts in command mode. The filename is listed in the bottom left corner of the initial window until you input the first text.

Various utilities such as PuTTY<sup>1</sup>, which is a free Telnet and secure shell (SSH) client for Windows and UNIX platforms, make vi easier to use. With PuTTY, for example, you can switch to insert mode from the other two modes. The Insert key also brings you from insert mode to replace mode.

## Commands for vi editor

This section lists the most frequently used vi commands.

### Navigating in the vi editor

Commands for moving the cursor in the editor are listed in Table 3-4.

Table 3-4 Navigating in the vi editor

Commands	Description
0	Move the cursor to the beginning of the current line.
\$	Move the cursor to the end of the current line.
Enter	Move the cursor to the beginning of the next line.
w	Move the cursor to the beginning of the next word.

<sup>1</sup> <http://www.putty.org>

Commands	Description
G	Move the cursor to the first non-blank position of the last line.

### ***Insertion point***

To switch from command mode to insert mode, place the cursor and then type one of the single-character insertion commands listed in Table 3-5. This establishes the insertion point as specified. After you enter the command, the cursor appears at the insertion point.

*Table 3-5 The vi insertion commands*

Command	Description
i	Move the cursor to before the current character.
I	Move the cursor to before the beginning of the current line.
a	Move the cursor to after the current character.
A	Move the cursor to after the end of the current line.
o	Move the cursor to the beginning of a new line that will be inserted before the current line.
O	Move the cursor to the beginning of a new line that will be inserted after the current line.

### ***Deleting***

Commands to delete text are listed in Table 3-6.

*Table 3-6 vi deleting commands*

Command	Description
x	Delete the current character.
nx	Delete n consecutive characters starting from the current character.
dw	Delete the current word.
D	Delete from the current character to the end of the line.
dd	Delete the entire current line.
dtc	Delete the current line through the next occurrence of character c.
:id	Delete line number i.

Command	Description
<code>:i,jd</code>	Delete line number <i>i</i> until (and including) line number <i>j</i> .
<code>:1,.d</code>	Delete the first line of the file through (and including) the current line. The dot (.) refers to the current line.
<code>:\$d</code>	Delete the current line through (and including) the last line of the file. Dot (.) refers to the current line. The \$ refers to the last line.

### ***Moving and copying***

Commands for moving and copy are listed in Table 3-7.

*Table 3-7 vi moving and copying commands*

Commands	Description
<code>:i mj</code>	Move line <i>i</i> , insert after line <i>j</i> .
<code>:i,jmk</code>	Move line number <i>i</i> through <i>j</i> (inclusive), insert after line <i>k</i> .
<code>:icoj</code>	Copy line number <i>i</i> , insert after line <i>j</i> .
<code>:i,jcok</code>	Copy line number <i>i</i> through <i>j</i> (inclusive), insert after line <i>k</i> .

### ***Replacing characters***

Commands for replacing characters are listed in Table 3-8.

*Table 3-8 vi replacing commands*

Commands	Description
<code>rc</code>	Replace the current character with <i>c</i> .
<code>:s/ppp/qqq/</code>	In the current line, replace the first occurrence of pattern <i>ppp</i> with <i>qqq</i> .
<code>:s/ppp/qqq/g</code>	In the current line, replace all occurrences of pattern <i>ppp</i> with <i>qqq</i> .

**Important:** In *vi*, words are delimited by a space and by any character that is not a digit and not a letter.

### Locating a string pattern

Commands to locate a specific string pattern are listed in Table 3-9.

Table 3-9 vi locating a string pattern

Commands	Description
/xxx <Enter>	Find the pattern xxx.
/ <Enter>	Find the pattern xxx of a previous /xxx command.
?xxx <Enter>	Find the pattern xxx (search direction is reversed towards the top of the file)
? <Enter>	Find the pattern xxx of a previous /xxx or ?xxx command.

**Note:** You may use a *regular* expression in the string pattern. For example [0-9] represents any digit and [a,e,i,o,u] represents any vowel.

### Miscellaneous vi commands

Miscellaneous vi commands are listed in Table 3-10.

Table 3-10 vi miscellaneous commands

Commands	Description
j	Go to line j (cursor at the beginning of this line).
u	Undo the most recent change in the current line.
U	Restore the current line to the state when it was first visited.
xp	Transpose the current character with the one next to it.
ddp	Exchange the current line with the next line.
~	Toggle the case of the current character.
n~	Toggle the case for n consecutive characters.
:help ccc	Get information about a command (ccc).

**Note:** The **xp** (transpose) command corrects a lot of typing errors by exchanging the order of two consecutive characters.

In case-sensitive programming languages, such as Java and C, many mistakes pertain to a wrong case. The ~ (tilde) command can correct this.

### ***Saving and closing a file***

Commands to save and close the file are listed in Table 3-11.

Table 3-11 *vi saving and closing commands*

<b>Commands</b>	<b>Description</b>
:w	Write to the file (save it).
:q	Quit the vi session.
:!q	Quit without saving.
:wq	Save first, then quit.

## **3.3 Exploring further**

For more information about the vi editor, study the tutorial available on your system. Copy the file `vimtutor` from the `/usr/bin` directory (or from another directory, depending on your installation) to your home directory. Then, execute the **vimtutor** command from your home directory. The tutorial also has exercises to help you practice using the commands. (An enhanced version of vi is vim.)

For general Linux information, see the *Linux Handbook A Guide to IBM Linux Solutions and Resources*, SG24-7000.

The following IBM Web sites have information about Linux:

- ▶ z/VM resources for Linux on IBM System z  
<http://www.vm.ibm.com/linux/>
- ▶ Linux on IBM System z  
<http://www.ibm.com/servers/eserver/zseries/os/linux/>
- ▶ System z mainframe  
<http://www.ibm.com/servers/eserver/zseries/>



# Installing z/VM and creating Linux or z/OS guests

In this chapter we introduce the concepts and steps required to perform z/VM installation. The chapter then discusses creating a Linux and z/OS guest to run under z/VM, from the moment you have finished using the HMC to create your LPAR to the point where you have guest systems up and running.

For information about using the HMC to wrap up the resources for your LPAR, see *Hardware Management Console V7 Handbook*, SG24-7491 and *IBM System Storage DS8000 Series: Architecture and Implementation*, SG24-6786.

## Objectives

After completing this chapter, you should be able to:

- ▶ Install a z/VM Operating System onto your LPAR
- ▶ Understand installation differences between z/OS and z/VM
- ▶ Set up the environment on z/VM for a Linux virtual machine
- ▶ Install Linux in a z/VM virtual machine
- ▶ Create and run a guest z/OS system

## 4.1 Initial installation of z/VM, compared to z/OS

This section is intended for z/OS system programmers, who have little or no experience with z/VM. This section should help you understand the basics of installing a z/VM system.

### 4.1.1 Installation methods and deliveries

Existing z/OS and z/VM sites usually perform their installation or upgrade tasks from an existing running system.

z/VM sites typically use an existing virtual machine to install a new z/VM system from a z/VM DDR (tape delivery) or DVD delivery. As of January 2008, the z/VM base operating system and base options became available for Internet delivery orders placed using ShopzSeries, in countries where it is available. See the following Web address for more information:

<http://www.vm.ibm.com/buy/edelivery/>

z/OS sites do the installations from an existing z/OS image using one of the available installation methods offered by IBM, currently ServerPac, CBPDO, or SystemPac®.

### 4.1.2 z/VM delivery

IBM offers only one delivery type to install z/VM, although an option for type of media (DVD or tape) is available.

### 4.1.3 z/OS deliveries

As mentioned, the available installation methods offered by IBM for z/OS are currently ServerPac, CBPDO, or SystemPac. This section describes each.

#### **ServerPac**

The z/OS installation method named ServerPac is a “software delivery package consisting of products and service for which IBM has performed the SMP/E installation steps and some of the post-SMP/E installation steps” (according to *z/OS V1R9.0 Planning for Installation, GA22-7504-17*). The package is an integrated set of products that have passed initial testing. This method involves the use of the CustomPac Installation Dialog, which allows the customer to customize aspects such as naming data sets and volumes, and placing data sets within the set of disks built during installation. Customers are given the choice of

either installing an IPL-ready z/OS image (including the necessary auxiliary data sets, page, SMF, for example) or installing just the products and establishing these auxiliaries at a later time.

### **CBPDO**

The Custom-Built Product Delivery Option (CBPDO) delivery consists of uninstalled and unintegrated service without dialog or tools to assist the installation process. The customer must perform this by using SMP/E.

### **SystemPac**

The last alternative, SystemPac, is a complete delivery of integrated products (even ISV products) to the customer's specification. It contains an IPL-ready system, including all necessary auxiliary data sets. It is available in two formats: full volume and dump-by-data-set. This type of delivery would probably be the only option for new z/OS customers.

### **Other deliveries**

See your IBM service representative for other delivery types or packages. Some types or packages consist of a more customized nature and might not be available for ordering from every region or country.

## **4.1.4 Comparing a z/VM installation to z/OS installation types**

By comparison, the SystemPac full-volume format-type delivery is similar to a z/VM delivery when a customer installs an operating system for the first time.

Both the SystemPac delivery and a z/VM DDR (tape) delivery (assuming a first time installation) imply the use of stand-alone (initial program load from tape) versions of the IBM Device Support Facility (ICKDSF) for formatting disk volumes and DFSMSDSS for z/OS or DDR for z/VM to restore the volumes. These activities are performed from the Hardware Management Console (HMC). By comparison, installing z/VM from a DVD delivery appears to be the easiest method to someone already familiar with z/OS.

By using the z/VM DVD delivery you have the ability to bring up a RAMDISK operating system, loaded into the System z processor memory. This system is functionally equal to z/VM itself and is invoked from the HMC using the Integrated 3270 Console facility. From within this operating system, you perform most of the remaining installation activities:

1. Invoke the executable INSTPLAN to specify which products to install, which language to use and type and volume serial numbers (volsers) of target DASD.

2. Use the executable INSTDVD to perform the main installation of z/VM.
3. Perform an IPL from the newly installed disk and run the executable INSTVM to finish the installation.

This method offers both a comprehensive dialog and a stable installation environment.

### **Remaining activities after a z/VM installation**

Usually, a z/VM delivery is accompanied by a Recommended Service Upgrade (RSU) tape or DVD. This should be installed after the initial installation has completed. It is installed from within z/VM using the executables SERVICE and PUT2PROD. For a discussion of these topics, refer to Chapter 9, “Applying system maintenance” on page 387.

### **Disk considerations**

Note that if you have duplicate volumes, z/VM uses the volume residing on the lowest device number without giving you an option. This is opposed to z/OS, which gives you the option of varying a device offline.

**Important:** Avoid having duplicates and establish a suitable standard for disk volume labels.

## **4.2 z/VM installation concepts and considerations**

Before going through a z/VM installation, this section provides concepts that are used throughout the installation. Become familiar with these before reading 4.3, “Installing z/VM in an LPAR” on page 138. The concepts can help you compare a z/VM installation and its required configuration to a typical z/OS installation and configuration.

### **4.2.1 Interacting with z/VM**

Differences do exist between z/OS and z/VM in terms of interacting with the system.

A user familiar with z/OS typically logs onto the system and uses an ISPF session to interact with the system<sup>1</sup>. System interaction is menu-driven, that is,

---

<sup>1</sup> For the purposes of this book, we make the assumption that most z/OS users interact with it by the use of ISPF instead of native TSO.

the user navigates through the menu to get to a particular system function or command to execute.

z/VM users, on the other hand, interact with the system through the Conversational Monitor System (CMS), which is a command-line interface<sup>2</sup> described in the following section.

## CMS

In a typical z/VM installation, CMS is the code that IPLs after a user logs in. It was designed to facilitate mainframe virtual machine administration. From within it, you can issue commands to edit, create, delete and manage files, and execute programs and scripts. In a simple analogy, CMS allows you to perform the same basic set of tasks as you would at a Linux console. Figure 4-1 illustrates a 3270 session displaying the CMS as user MAINT logs on. An overview of CMS is located in section 2.5, “Conversational Monitor System (CMS)” on page 35.

A CMS interface is depicted in Figure 4-1. Notice how similar CMS looks like to a Linux console session. Most users are familiar with the concept of working with a console session; interacting with CMS is not much different.

```
LOGON MAINT
ENTER PASSWORD (IT WILL NOT APPEAR WHEN TYPED):

z/VM Version 5 Release 3.0, Service Level 0701 (64-bit),
built on IBM Virtualization Technology
There is no logmsg data
FILES: 0098 RDR, NO PRT, NO PUN
LOGON AT 14:35:40 EDT FRIDAY 05/09/08
z/VM V5.3.0 2008-05-06 13:40

VM READ VMLINUX6
```

Figure 4-1 Logon window and CMS

You should be familiar with how to use the CMS help menu. Read section 2.5.1, “Overview of the HELP command in CMS” on page 36 for an introduction to the subject.

The following list has commands you are most likely to use to find, copy, and edit files:

- ▶ FILELIST

<sup>2</sup> CMS is not a simple command shell, but an entire operating system by itself.

Use this command to list files in z/VM, from within CMS. z/OS users usually do this through a menu interface, ISPF. See “The COPYfile command” on page 75 for details about this command.

▶ COPYFILE

Use this command to create backup copies of the configuration files you will edit. The syntax for this command is in “The COPYfile command” on page 75.

▶ XEDIT

The two ways to edit a file in CMS are:

- When you already know the file name and where it is.

This is the straightforward scenario. To edit a file named PROFILE EXEC that you have on your A disk, type the following on the CMS command line:

```
xedit profile exec a
```

- When you do not know what the file name is, or where it is, or both.

In this scenario, you search for the file to edit by using the FILELIST command to view the list of files. Then, place your cursor on the line corresponding to the file you want to edit, and press F11.

Although throughout the installation you will use these three commands to manipulate files, spend a few more minutes looking at section 2.8.2, “CMS” on page 72 to learn about other commands. Also, read the appropriate chapter of the book *Introduction to the New Mainframe: z/VM Basics*, SG24-7316 to become familiar with z/VM commands.

## 4.2.2 System files

As within every system, z/VM has configuration files. They are used to define minidisks for users, define virtual resources such as virtual switches, define profiles for CMS and XEDIT sessions, and so on. This section describes the following files:

- ▶ USER DIRECT
- ▶ SYSTEM CONFIG
- ▶ PROFILE EXEC
- ▶ PROFILE XEDIT

You will learn how to access and modify each of these files when the time comes throughout the installation.

**z/OS analogy:** The configuration files discussed here are the z/VM counterparts of z/OS SYS1.PARMLIB concatenation, RACF definitions of users, and your initial TS0/ISPF routine invoked from your logon procedure JCL

### The USER DIRECT file

This is the z/VM configuration file that handles the definitions for users and their minidisks, DASD space allocation, and definitions for common profiles that users can import into their user settings. These profiles are meant, among other things, to create basic devices such as the *reader*, *punch*, and *print* spoolers needed by every user for input, output, and printing files and for creating links to other user's disks, in particular to some of MAINT user's disks, in order to access critical read-only code, such as the CMS, without duplication into their minidisks. This file is located on MAINT's 2CC disk.

### The SYSTEM CONFIG file

This file holds most of the configuration for the system. It is in this file that you set up which DASD volumes will be owned by the system, for example the ones that are dedicated to paging, and which ones are user-owned, for example volumes that host Linux virtual machines. It is also used to set up virtual resources, such as virtual switches that are used to serve networking to Linux VMs, and to limit the amount of resources given to ordinary users, such as the number of minidisks each may own. This file is located on MAINT's CF1 disk.

### The PROFILE EXEC file

A PROFILE EXEC is different from other executables (also known as *execs*). It has the special file name, PROFILE, and it is automatically processed whenever you enter IPL CMS (or if you have an automatic IPL mechanism in place).

Your PROFILE EXEC contains the CP and CMS commands that you enter at the start of every terminal session. It can be used to set up special characteristics for each CMS user, beyond those defined in that user's directory entry, such as:

- ▶ Making any nonstandard minidisks or shared file systems in your virtual machine configuration known to CMS
- ▶ Changing the colors that display data at a terminal (color terminals only)
- ▶ Making frequently used execs storage-resident
- ▶ Setting up to 24 program function keys for commonly used commands
- ▶ Changing the Ready message sent by CMS
- ▶ Automatically checking your virtual card reader (your *in-tray*) for files and messages
- ▶ Taking you directly to an application instance

Each z/VM user has its own PROFILE EXEC file. This is similar to the Linux .bashrc file, and the z/OS initial logon routine (REXX or CLIST scripts that are installation customizations and not part of the standard z/OS TSO logon). Every time a user logs in, this file is accessed and any special configurations and commands in it are set or run. Maintaining the same profile among users is a good practice for ensuring a homogeneous look and feel when you log on to different user accounts. This file is located on the 191 disk of each z/VM user.

### **The PROFILE XEDIT file**

This is the configuration file for the XEDIT editor and is accessed every time a user invokes it. As you have seen in “Customizing XEDIT” on page 91, a good customization of this file is critical for a better experience using XEDIT. This file is similar to the .vimrc file in Linux for its vi editor. In z/OS, this is similar to profile settings set up in the ISPCFIGU module. This file is located on the 191 disk of every z/VM user.

## **4.2.3 Important z/VM installation user IDs**

As with every system, some user accounts have a special meaning. This section outlines those accounts used throughout a z/VM installation, and makes a comparison to z/OS and Linux. The user accounts are:

- ▶ MAINT user
- ▶ AUTOLOG1 user
- ▶ TCPIP user

### **The MAINT user**

This is z/VM's super user. It is analogous to the a z/OS user with access to system-privileged information through RACF. It is also analogous to the Linux root user.

This z/VM user has access to all of the privilege classes mentioned in 6.1.5, “z/VM privilege classes” on page 287. It is granted, therefore, access to all of the system's configuration files and management commands, such as granting a user access to a virtual switch.

### **The AUTOLOG1 user**

This is a special user in z/VM and there is no comparable user in either z/OS or Linux. The closest concept to it in Linux are the run levels, which are responsible for bringing up services during startup.

Running commands or scripts automatically right after z/VM IPLs is accomplished through the AUTOLOG1 user. As mentioned in 2.2.1, “History of



z/VM” on page 14, the concept of a z/VM user maps to a virtual machine. So, the AUTOLOG1 *virtual machine* is responsible for starting up other virtual machines (logging on other users) as soon as the z/VM IPL finishes. This is usually done to bring up the TCP/IP virtual machine, for example.

**Note:** If the noautolog parameter is *not* specified when z/VM is loaded (IPL), the AUTOLOG1 virtual machine is started. Because this virtual machine IPLs CMS, the PROFILE EXEC that is found on its A disk is run. This is analogous to the /etc/profile file on Linux and the autoexec.bat file on DOS systems.

**z/OS analogy:** The tasks performed by the z/VM AUTOLOG1 user are similar to using START statements in members IEACMDxx and COMMNDxx in the SYS1.PARMLIB concatenation

### The TCPIP user

In z/OS, the TCP/IP stack is managed by the z/OS Communications Server in a separate address space. In z/VM, however, the stack is managed by a virtual machine: the TCPIP virtual machine (defined as the TCPIP user).

## 4.2.4 Dealing with disks

A file hierarchy is run in CMS when a z/VM user logs into the system. It is a different hierarchy than the one used by Linux or z/OS. In fact, there is no hierarchy in CMS, but it does have the *triplets* concept of file name, file type and file mode. Every file name is formed by these three components, which are described in the following list. You can think of this file system as a flat file system (or sequential) in which you have only one level.

- ▶ The first parameter, the file name, should be familiar to most users because it is just the name of the file. In CMS, file names are limited to eight characters in length and are *not* case-sensitive.
- ▶ The second parameter, file type, is analogous to the file extension of systems such as Linux. In CMS, file types are also limited to 8 characters in length and are *not* case-sensitive. In an analogy, the file name and file type together form something similar to the z/OS filename.extension (with a space instead of a dot between them) file naming convention of other systems.
- ▶ The third parameter, the file mode, specifies where the file is located, that is, on which disk mapping it resides. The file mode is one character long and is limited to the characters A-Z. The file mode is what makes the whole filesystem a flat universe because you are limited to having 26 simultaneous *places* to put your files.

We mentioned the word *mapping* in the previous paragraph, but before we talk about mapping a disk to a file mode, we should discuss how disks are organized. Disks are nothing more than storage space. They hold files, and the files on them are identified by their name and type. However, instead of systems such as Linux, disks are not identified by device names, they are identified by device IDs. Some of these IDs are well known IDs, such as MAINT's 193 disk, which contains useful programs such as CPSYNTAX.

The disk ID is an analogy to a template directory name in systems such as Windows. For example, two z/VM users can have 191-labelled disks. Think of this as the *My Documents* folder that two different users can have in Windows. Both folders have the same name, *My Documents*, but each of them belongs to a different user and each of them denotes a different area in disk storage. The only difference here is that you are using numbers in CMS instead of names to denote a permanent storage area, that is, a disk. For z/OS, each TSO/ISPF user has an individual ISPF.PROFILE file under that user's own high-level qualifier.

Having said that, we further explore several interesting aspects of disks. If, for example, you want to access the CPSYNTAX command and you are not logged on as MAINT, you can *link* MAINT's 193 disk to your user space to be able to access that command. The way you do this is by using the commands LINK and ACCESS (or its abbreviation: **acc**).

### Accessing another user's disk (linking)

The sequence of commands to link another user's disks to your user space is shown in Example 4-1.

*Example 4-1 Linking and accessing disks*

---

```
link autolog1 191 1191 rr
Ready; T=0.01/0.01 16:02:04
acc 1191 f
DMSACP723I F (1191) R/O
Ready; T=0.01/0.01 16:02:08
```

---

The LINK command shown in the example links disk 191 of user AUTOLOG1 to our user space under the label 1191 in read-only mode. This means that we can actually access the files on AUTOLOG1's 191 disk by referencing our own *linked* 1191 now. However, to perform that we still have to *map* our 1191 disk to a *file mode* so that we can use a *triplet* (file name, file type, file mode) to access the files on it. Mapping a disk to a file mode is what we performed with the ACCESS command<sup>3</sup>. We mapped our 1191 disk to one unused file mode that we had

---

<sup>3</sup> In z/VM, *mapping* a disk, as we defined the term, is actually known as *accessing* a disk. We used the word map here to make the analogy easier to understand by people not familiar with z/VM. From this point on, we refer to disk mapping as accessing disks.

available, which in this case was *F*. Figure 4-2 shows what we have just performed.



Figure 4-2 Accessing other users' disks.

To check that AUT0LOG1's 191 disk is linked and mapped to our user space, we can run `QUERY4 DISK` and check whether there is an entry for our newly mapped *f* file mode. The output of the command is depicted in Figure 4-3 on page 132. Notice that the *f* file mode is our virtual disk with ID 1191 and that its label is AUT191, as we would expect.

**Note:** If you try to link to another user's disk and you are not logged in as MAINT, you might have to enter a password for the access mode (read, write) you are linking the disk in. Refer to "Creating a disk" on page 134 for more detail on access modes.

<sup>4</sup> The abbreviation for the QUERY command is `Q`.

```

LOGON MAINT
z/VM Version 5 Release 3.0, Service Level 0701 (64-bit),
built on IBM Virtualization Technology
There is no logmsg data
FILES: 0113 RDR, NO PRT, NO PUN
LOGON AT 09:31:14 EDT TUESDAY 05/13/08
z/VM V5.3.0 2008-05-06 13:40
link autolog1 191 1191 rr
Ready; T=0.01/0.01 09:32:11
Ready; T=0.01/0.01 09:32:11
acc 1191 f
DMSACP723I F (1191) R/O
Ready; T=0.01/0.01 09:32:20
query disk
LABEL VDEV M STAT CYL TYPE BLKSZ FILES BLKS USED-(%) BLKS LEFT BLK
TOTAL
MNT191 191 A R/W 175 3390 4096 10 28-01 31472 31500
MNT5E5 5E5 B R/W 9 3390 4096 131 1288-80 332 1620
MNT2CC 2CC C R/W 5 3390 4096 54 434-48 466 900
MNT51D 51D D R/W 26 3390 4096 273 1245-27 3435 4680
AUT191 1191 F R/O 1 3390 4096 2 9-05 171 180
MNT190 190 S R/O 100 3390 4096 687 14592-81 3408 18000
MNT19E 19E Y/S R/O 250 3390 4096 1010 26738-59 18262 45000
Ready; T=0.01/0.01 09:32:23

RUNNING VMLINUX6

```

Figure 4-3 Checking that disks have been linked and mapped

Users of AIX-like systems can think of linking and accessing as soft linking to another user's directory. This naturally brings the idea of facing a file mode as a mapped directory to our flat CMS file system. For readers who thought that living without directories would be difficult in z/VM, you see that you can manage 26 different directories at the same time. Simply keep in mind that each of these *directories* is actually a disk.

To *release* a linked disks from your user space, use the **RELEASE** command (or its abbreviated form: **REL**). To release the *f* disk that we just accessed, use the **RELEASE f** command.

## Disk access conventions

Now that you have learned the basic concepts of disk access, this section describes several conventions related to disk access.

The A CMS user typically has at least two available disks (probably minidisks, which we discuss later). Usually with CMS, a user has a pair of virtual disks with addresses 191 and 190:

- ▶ The 191 disk is conventionally accessed with mode A.
- ▶ The 190 disk is accessed as S. The 190 minidisk is sometimes known as the *CMS system residence volume*, because it is where the CMS nucleus resides on disk.

### **Your A disk**

CMS assumes that you have disks at addresses *190*, *191*, and *19E*. It also determines whether you have a disk at address *192*. When CMS loads, these disks are accessed as follows:

- ▶ 191 becomes the A disk
- ▶ 192 becomes the D disk (if it exists)
- ▶ 190 becomes the S disk
- ▶ 19E becomes the Y/S disk

This succeeds only if your user has DASD with a virtual address of 191. The A disk is a work disk for a user's permanent file storage. Generally the A disk of CMS users is the only writable disk they have access to. This is similar to the home directory of users in systems that account user DASD space.

The A disk is exceptionally important because when CMS is loaded, it looks for a file named `PROFILE EXEC` on your A disk and attempts to execute that file.

The `PROFILE EXEC` is often modified to customize the CMS instance for a given user, or even to load another operating system like Linux.

### **Running out of space**

Each virtual disk is divided into blocks that are usually 4096 bytes in size (although some disks, such as the help disk, use smaller blocks to save wasted disk space from the number of small files on them).

The minimum size of each file is one block. The maximum is limited by the size of the minidisk. Each user normally has read-access to a number of these types of disks. But often, users have trouble when they have no remaining space to write their own files.

For this reason, knowing how much space remains on one of your accessed disks is important. You can view this and other useful information by using the QUERY DISK command.

**Note:** The QUERY DISK command is different from the QUERY DASD command. QUERY DASD is a CP command for *devices*. QUERY DISK is a CMS-only command used for viewing your *accessed volumes*.

Completely filling up a disk, such as your A disk is possible. In this situation, the system does not give you more space automatically. You must take action to get more space or erase unnecessary files.

To acquire more space you could attach a new DASD volume, and then format and access it. Another option is to link to another disk you have write access to or to create a temporary disk if you do not need to persistently save the data. More information about this is provided in 5.3.9, “Managing DASD” on page 258.

## Creating a disk

This section explains how to create a disk and the concepts behind it. The section after this explains how to format a disk.

The MAINT user in z/VM has access to many interesting system configuration files. Some of them are used for letting the system know which 3390 DASDs to automatically bring online in system boot, some are common profiles for ordinary users, and others are for managing the creation of minidisks in those DASDs. In this section we are interested in creating minidisks for our users. A minidisk is a portion of the 3390 disk.

The file that assigns minidisks to users is called USER DIRECT and it is on MAINT's 2CC disk, which is accessed using the C file mode. We begin by analyzing the portion of this file in which we are interested. Figure 4-4 on page 135 shows the minidisks for user CERON<sup>5</sup>.

---

<sup>5</sup> We used an general user as an example instead of MAINT because there are too many disk definitions and links for MAINT, which could lead to confusion.

```

USER DIRECT  C1 F 80 Trunc=72 Size=2041 Line=1967 Col=1 Alt=0

01967
*****
01968 USER CERON CERON  32M 64M G
01969 INCLUDE IBMDFLT
01970 ACCOUNT ACT4 CMSTST
01971 MACH XA
01972 IPL 190
01973 MDISK 191 3390 2040 010 LX6W02 MR READ  WRITE  MULTIPLE
01974 *
01975
*****
====>

```

Figure 4-4 Disk definitions for a general user

The first line, number 1968 in the file, defines the user CERON and sets his password to the word CERON too. Although creating simple passwords is not a good practice, for the sake of the examples throughout this book we set the password to be the same as the user name. The two parameters, 32M and 64M, indicate the initial and maximum amount of system storage (main memory) that this user's virtual machine will use. The ending G in that line indicates the class privileges that this user will have access to, which in this case is the lowest possible. Creating a user is discussed in "Creating the Linux MAINT user" on page 183.

The second line, number 1969, adds a default profile called IBMDFL to the user definition. Later, if you look at the beginning of the USER DIRECT file, you will notice that this profile links some of MAINT's disks to this user's user space. For example, it links MAINT's 190 disk to its own 190 disk in read-only mode. This allows this user to load (IPL) CMS when he logs on.

Line 1973 shows the definition of the minidisk for that user. It defines its 191 disk, on the 3390-3 type DASD labelled LX6W02 starting at cylinder 2040 and being 10 cylinders in size in multi-read mode. Additionally, it defines three passwords, READ, WRITE and MULTIPLE for users who want to link to that disk in read, write and read-write modes respectively.

After a disk definition is inserted for a given user, changes do not take place until you tell the system to perform them. To do this, use the DIRECTXA USER command, but first checking the minidisks' layout for gaps and overlaps before you actually commit your changes<sup>6</sup> is good practice. To check your changes, run DISKMAP USER, which creates a file named USER DISKMAP in your A file

mode. Then, look for the new user minidisk definition. Figure 4-5 shows the lines in that file and that refer to our newly created user.

```
USER   DISKMAP A1 F 80 Trunc=80 Size=382 Line=231 Col=1 Alt=0

00231
00232 VOLUME USERID CUU DEVTYPE START END SIZE
00233 LX6W02 $ALLOC$ A03 3390 00000 00000 00001
00234 40SASF40 2D2 3390 00001 00150 00150
00235 OSADMIN2 191 3390 00151 00160 00010
00236 OSADMIN3 191 3390 00161 00170 00010
<...snap...>
00318 COSTA 191 3390 01806 01815 00010
00319 HAIMO 191 3390 01816 01825 00010
00320 1826 1999 174 GAP
00321 GUILLE 191 3390 02000 02009 00010
00322 OMAR 191 3390 02010 02019 00010
00323 RAY 191 3390 02020 02029 00010
00324 KEN 191 3390 02030 02039 00010
00325 CERON 191 3390 02040 02049 00010
====>
```

Figure 4-5 Checking DASD layout for gaps and overlaps

Notice in Figure 4-5 that line 00320 (in bold) shows a gap starting at cylinder 1826 and running through cylinder 1999, for a total of 174 cylinders. Although you should try to avoid gaps to prevent fragmentation, they are harmless. The second bold line (00325) shows the newly created user; no overlap exists between it and any of its surrounding minidisks definitions. Having checked that, we must run `DIRECTXA USER` for the changes to take place.

### Formatting a minidisk

After a new user is created, its owner should format its assigned minidisk space so that files can be created for that disk. This is accomplished by running the `FORMAT` command after the user logs on:

```
format 191 a
```

This command formats the user's 191 disk and uses it as the A file mode. See Figure 4-6 on page 137

<sup>6</sup> Gaps only leave empty disk space between minidisks, but an overlap occurs when one minidisk definition overlaps into following minidisks; z/VM actually allows this overlap.



```
LOGON GUIL
z/VM Version 5 Release 3.0, Service Level 0701 (64-bit),
built on IBM Virtualization Technology
There is no logmsg data
FILES: NO RDR, NO PRT, NO PUN
LOGON AT 12:28:57 EDT TUESDAY 05/13/08
z/VM V5.3.0 2008-05-06 13:40

format 191 a
DMSFOR603R FORMAT will erase all files on disk A(191). Do you wish
to continue?
Enter 1 (YES) or 0 (NO).
1
DMSFOR605R Enter disk label:
gui191
DMSFOR733I Formatting disk A
DMSFOR732I 10 cylinders formatted on A(191)
Ready; T=0.01/0.01 13:14:27

RUNNING VMLINUX6
```

Figure 4-6 Formatting a minidisk

**Note:** When you log on to your user account for the first time, your 191 disk (the A disk) will probably not have been formatted. You can check whether you have a suitably formatted A disk by executing the command FILELIST<sup>a</sup>. If you see a file listing after executing the FILELIST command, then it has already been formatted.

However, if you receive the following error message, you might have to format your 191 disk before continuing:

```
HPCMD001E Unknown CP command: FILELIST
```

If this is the case, use the command **FORMAT 191 A** to place a VM readable file system on your A disk.

a. The abbreviated form for the FILELIST command is FILEL.

## 4.3 Installing z/VM in an LPAR

This section discusses installation of z/VM in an LPAR. For more detailed installation instructions, see:

<http://www.vm.ibm.com/install/vm53inst.pdf>

### 4.3.1 Planning

Before starting the z/VM and Linux installations, plan carefully to make sure you have the following required resources:

- ▶ Hardware
- ▶ Software
- ▶ Networking

Planning also involves considerations for passwords, disks, memory, and for creating a resources worksheet.

#### Hardware resources

The following hardware is required:

- ▶ A System z logical partition (LPAR); z800, z900, z890 or z990, System z9® or System z10:
  - Processors or CPUs: One IFL (or CP) minimum, two or more are strongly recommended. In Systems z9 and earlier systems you are not able to mix general CPUs and IFLs.
  - Memory: 3 GB central with 1 GB expanded minimum, 6 GB with 2 GB or more recommended. This 3:1 ratio of central to expanded storage is a good starting point for all systems except the very largest systems.  
See the following Web site for a discussion of how to apportion memory:  
<http://www.vm.ibm.com/perf/tips/storconf.html>
  - DASD: twelve 3390-3 or five 3390-9 at a minimum
  - Open Systems Adapter (OSA) network cards: One card minimum with eight device numbers (technically six, but OSA *triplets* usually start on an even address). Two OSA Express cards with eight device numbers on one card, and four on the other is recommended for high availability.
- ▶ A network-attached computer that can act as a file server of Linux distributions with at least 3 GB of disk space plus 6 GB for each Linux distribution that you intend to serve, although more might be needed.

Setting up a server is *not* described in this book, however we reference helpful publications in the following section, “Software resources” on page 139.

- ▶ A workstation or desktop that has network access to the mainframe

## Software resources

The following software resources are required:

- ▶ z/VM 5.3 installation media with documentation (installation from DVD is described in this book).
- ▶ Linux installation media (SLES or RHEL)
- ▶ An operating system for the file server
  - You can easily set up a file server by using an existing Linux environment. The *z/VM and Linux on IBM System z: The Virtualization Cookbook for SLES9*, SG24-6695 book has instructions for setting up an NFS server.
  - Additional options to an NFS server are HTTP or FTP, served on the Apache server or on usual FTP servers found on Linux distributions. Instructions for setting up Apache are at the following Web site:  
<http://www.apache.org/>
- ▶ The code associated with this book
- ▶ Tools on the workstation and desktop:
  - A 3270 Emulator such as Attachmate Extra, Hummingbird Host Explorer, or IBM Personal Communications for Windows desktops (for Linux desktops, a 3270 emulator named *x3270* is available)
  - A Linux SSH client such as PuTTY (recommended) or TeraTerm (for Linux desktops the SSH client is built in)
- ▶ A VNC viewer

## Networking resources

The following network resources are required:

- ▶ A TCP/IP address for z/VM
- ▶ One TCP/IP address for each z/OS, z/VM or Linux guest operating system
- ▶ Associated TCP/IP information:
  - DNS host name
  - DNS domain
  - DNS server TCP/IP address
  - TCP/IP gateway
  - TCP/IP subnet mask

- TCP/IP broadcast address (usually calculated from address and subnet mask)
- TCP/IP MTU size

The TCP/IP addresses should be routed to the OSA card or cards.

### **z/VM users and password planning**

Good passwords are critical to good security. However, requiring many different passwords generally leads to people writing them down, which clearly detracts from good security. Sometimes it is difficult to balance these two extremes.

This book considers the following system administration roles:

- ▶ z/VM system administrator
- ▶ Linux system administrator
- ▶ Linux virtual server users

The z/VM and Linux system administrator can be the same person.

**Important:** For the purposes of this book, all passwords have been set to be the same as of the user name. However, be sure to realize, that in your company environment, it is a risky thing to do.

You might want to define a finer granularity for passwords based on the following system administration roles:

- ▶ The main z/VM system administrator (MAINT)
- ▶ The z/VM network administrator (TCPMAINT)
- ▶ The z/VM Linux administrator (LNXMaint, Linux guests administrator)
- ▶ The Linux virtual server users (with or without access to 3270 sessions, with or without the root passwords)

The sets of passwords you define depends on the roles your organization adopts.

**Note:** If you want to move your existing z/OS system onto z/VM and run it as a z/VM guest system (see 4.5, “Running a z/OS image as a z/VM guest” on page 219), you also have to define an administrator password for the z/OS guest virtual machine. Please remember that you cannot run z/OS under z/VM on an IFL.

## Disk planning

In the planning stage, consider the following aspects when choosing and allocating disk storage:

- ▶ Conventional ECKD™ DASD versus FBA disks over SCSI/FCP
- ▶ 3390-3 versus 3390-9 or large disk support
- ▶ Amount of disk storage per Linux image and how to allocate file systems

### ***DASD versus SCSI/FCP***

This book describes how to use conventional ECKD DASD and does not discuss FBA disks accessed over SCSI/FCP. The reason is not because either technology is superior, but because DASD seems more common than SCSI/FCP disks. Sometimes, a combination of these two types of disk storage is used. When that is the case, the ECKD emulated DASD is often used for the root file system and SCSI/FCP disks are used for large data storage areas.

### ***3390-3 versus 3390-9***

Emulated 3390-3 format is about 2.3 GB, and 3390-9 format is three times the size or about 6.8 GB. Either size will work, although several performance analysts recommend the 3390-3 instead of 3390-9. This book mainly describes using 3390-3s, however, where differences exist when using 3390-9s, we added comments, especially when installing z/VM.

### ***Disk storage per Linux image***

To install a graphical environment (the K Desktop Environment) into our Linux guest and also to retain lots of free space for general purpose tasks (that the authors would like to play around with), we decided to use about 10 GB of storage for the guest. The amount of space you will need for your particular goals with Linux on z/VM can vary, but having a root partition (*/*) of 3 GB to 4 GB, at least, is recommended for any Linux installation because, with the extra space, you might easily grow later from a minimal package set to a full package set installation.

In our examples, five 3390-3s, each comprising 3339 cylinders, are allocated for the Linux image. Often, recommendations are made to create many file systems to be mounted over directories other than the root file system itself (*/*), such as */usr/*, */var/*, */tmp/*, */home/*, */opt/*, and others. We do not do this for all of our examples because:

- ▶ We are not optimizing the installation for any particular use. For more information about optimizing Linux partitioning, read *Linux Performance and Tuning Guidelines*, REDP-4285.

- ▶ We initially have only 10 GB available for the installation, and segregating storage with that little space can lead us to too many small partitions that will bring the system to a useless state very quickly.

One common argument for having many mounted file systems is to prevent the root file system from filling up, bringing the system to a halt. For example, in a production environment where the Linux guest is acting as a file server, remote attacks can cause the logs in /var to consume all of the space of the partition on which it resides. This can halt the system if /var resides on the same partition as the root partition (/).

**Note:** Having a good partitioning plan is the first step to having an optimized and reliable Linux guest.

## Memory planning

Planning memory can be the most difficult issue with Linux on System z and z/VM, yet the most important to ensure adequate performance. The simplest solution can appear to involve having enough central memory (storage) in the LPAR so that z/VM never pages and Linux never swaps. However, such resource is often not realistically available. A good rule of thumb is to allocate memory on a just-enough basis for each Linux server. A good starting point is to set a virtual-machine size by changing the memory allocation value at just over the value at which the guest starts to swap at the Linux system level, when under normal loading. If some level of sustained swapping is inevitable because of the nature of the workloads, then ensure virtual disks are used for the swap media.

Understanding memory planning is definitely recommended. The following books discuss this very important topic:

- ▶ The book *Linux on IBM System z: Performance Measurement and Tuning*, SG24-6926 on the Web at:  
<http://www.redbooks.ibm.com/redpieces/abstracts/sg246926.html?Open>
- ▶ The IBM z/VM Performance Resource pages in general, on the Web at:  
<http://www.vm.ibm.com/perf/>
- ▶ Configuring Processor Storage, at:  
<http://www.vm.ibm.com/perf/tips/storconf.html>

One rule that can be recommended is to only have as few virtual machines logged on (or disconnected) as possible to handle the workload. Every virtual machine that is not required should be logged off where appropriate. The result is more memory for the other virtual servers that remain running.

We set up our examples with Linux guests that are allocated 512MB of initial storage plus more 1.5 GB of extended storage (for Linux swap). This is more than enough for the purposes of this book.

## The planning worksheets

This section presents a worksheet that lists the values of the resources used in the examples throughout this chapter. See Table 4-1. Refer to this worksheet, as you create your own planning worksheet in Appendix B, “Planning worksheet” on page 403.

**Note:** In this book, all examples that run commands requiring resource information show the resource value encapsulated within angle bracket (<->) characters. When you run the commands on your system, make sure to replace our example values with your own resources.

Table 4-1 z/VM resources worksheet

Name	Value	Comment
LPAR name	VMLINUX6	Storage: 4 GB + 2 GB Ext Processors: 4 DASD: 11 3390-3 disks
CPC name	SCZP201	Name of CPC on which the LPAR is located
z/VM system name	VMLINUX6	Name to be assigned to z/VM system
TCP/IP host name	vmlinux6	Assigned by a network administrator; helpful to set in DNS beforehand, but not necessary
TCP/IP domain name	itso.ibm.com	Helpful to set in DNS beforehand
TCP/IP gateway	9.12.4.1	The router to and from the local subnet
DNS server 1	9.12.6.7	Assigned by the network administrator
DNS server 2/3 (optional)	—	Not used
OSA device name	eth0	Name of the interface to be assigned by IPWIZARD

Name	Value	Comment
OSA starting device number	3020	Start of OSA <i>triplet</i> for the z/VM TCP/IP stack
TCP/IP address	9.12.4.89	The TCP/IP address of the z/VM system
Subnet mask	255.255.252.0	Assigned by network administrator
OSA device type	QDIO	Often “QDIO” for OSA/Express cards
Network type	Ethernet	Usually “Ethernet”
Port name (optional)	—	Not required by z/VM
Router type	None	Usually “None”
Primary OSA device number for VSWITCH	3024	Specify the first device number (must be even number) and the next two device numbers will also be used
Secondary OSA device number for VSWITCH	3028	Should be on a different CHPID/OSA card
DASD addresses for z/VM	1A20 - 1A24	3390-3s to host z/VM
DASD addresses for Linux	1A25 - 1A29	3390-3s to host Linux guest
DASD addresses for paging	8228	3390-3s to host Linux swap space

After you create your worksheet by using the template provided in Appendix B, “Planning worksheet” on page 403, and you have all of your resources planned for a z/VM and Linux installation, we can do some real work.

**Note:** You should be familiar with basic z/VM concepts. If you are not, refer to 2.8, “Getting started with basic commands for z/VM” on page 65 and the previous sections of this chapter.



## 4.3.2 Installing z/VM from DVD

This section assumes you have a first-level installation of z/VM from DVD onto DASD. Make sure you:

- ▶ Complete the worksheet in Appendix B, “Planning worksheet” on page 403.
- ▶ Have access to the Hardware Management Console (HMC) with a user ID that has authority to go into single object operations mode.

z/VM 5.3 is shipped on tape and DVD. z/VM should install faster from tape because of faster I/O speeds, however, installing from tape might require more trips between the HMC and the tape drive.

If you are familiar with the HMC, you can use the two page *z/VM Summary for Automated Installation and Service (DVD Installation)* to replace or augment the description that follows.

If you are not familiar with the HMC and z/VM, you might want to use the complete installation manual *z/VM Guide for Automated Installation and Service Version 5 Release 3.0*, GC24-6099. It is out of the scope of this book to describe setting up an LPAR in the HMC for the system; there is no difference between creating an LPAR for z/VM and creating one for z/OS.

If you are installing z/VM at the *second level* (z/VM under z/VM) or onto SCSI disk, use the z/VM manual because the following sections do not address these options.

### Installing z/VM from DVD

This section explains how to install z/VM 5.3 from an HMC with a DVD-ROM onto 3390-3 equivalent DASD. We also point out differences for installing onto the larger 3390-9 DASD. For alternative configurations, such as installing from tape or onto SCSI disks, refer to the z/VM documentation.

To install z/VM from DVD:

1. On the Hardware Management Console, select the LPAR on which you want to install z/VM.
2. If necessary, click the **racetrack** buttons (two buttons that are circular arrows on the bottom right corner) to traverse to the CPC Recovery (sometimes named just *Recovery*) menu.
3. On the CPC Recovery menu, double-click the **Integrated 3270 Console** as shown in Figure 4-7 on page 146. A window named “Integrated 3270 Console for <yourCPC>” opens (on older HMC levels, the window might be named Personal Communications).

**Hint:** Use the Alt+Tab key sequence to conveniently move between the HMC window and 3270 console.

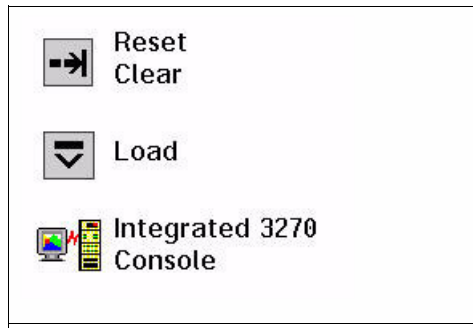

Figure 4-7 Integrated 3270 Console icon

4. Place the “z/VM Product Package Version 5 Release 3.0” DVD in the HMC DVD drive.
5. Get into Single Object Operations mode, as follows:

**Note:** On the z10, you do not have to go to Support Element (SE) mode to load from DVD.

- a. Double-click the **Groups** icon in the Views area.
- b. Double-click **Defined CPCs** in the Groups Work Area.
- c. Select your CPC.
- d. If necessary use the buttons with circular arrows on the bottom right corner to navigate to the CPC Recovery menu.
- e. Double-click the **Single Object Operations** icon. Click **yes** to confirm. Now a new window, *Primary Support Element Workplace*, should appear (on older HMC levels it will be a “window within a window”). A window about a certificate can appear. If so, click **OK**.
- f. Double-click **Groups** near the top of this window.
- g. Double-click **Images** in the Groups Work Area.

**Important:** If you are unable to get into Single Object Operations mode, you might not have sufficient permission. Ask your system administrator.

6. Select the LPAR that z/VM will be installed into.

7. Go around the racetrack in this window to the CPC Recovery menu, shown in Figure 4-8.

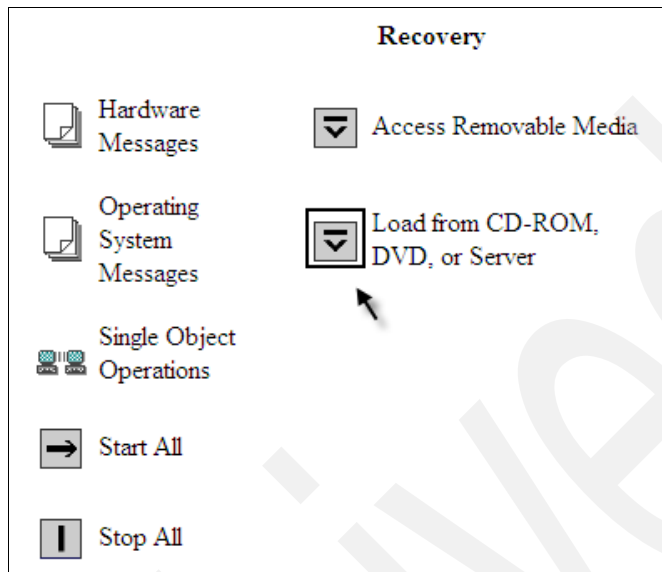

Figure 4-8 CPC Recovery menu

8. Double-click the **Load from CD-ROM, DVD, or Server** icon. The “Load from CD-ROM or Server” panel opens (Figure 4-9 on page 148).

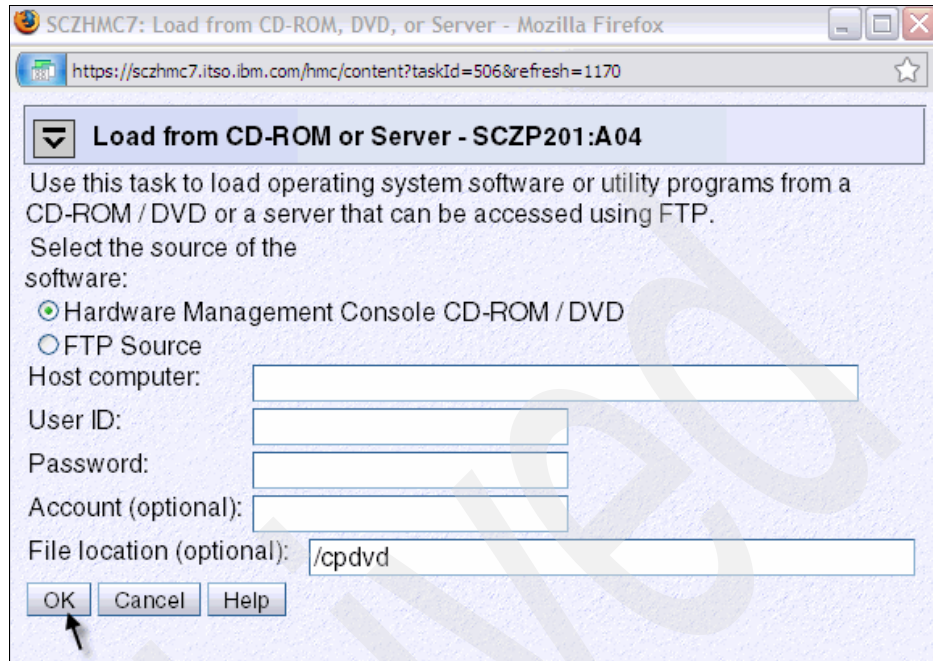

Figure 4-9 Load from CD-ROM or Server panel

9. Select the **Hardware Management Console CD-ROM/DVD** button, if it is not already selected.
10. Type `/cpdvd` in the File location field. This is the directory on the DVD with the z/VM 5.3 installation code.
11. Click **OK**.
12. Load the ramdisk. A list of software is displayed in the “Load from CD-ROM or Server” panel. To load the ramdisk:
  - a. Select, if it is not already selected, the software `530vm.ins` as shown in Figure 4-10 on page 149, and then click **OK**.

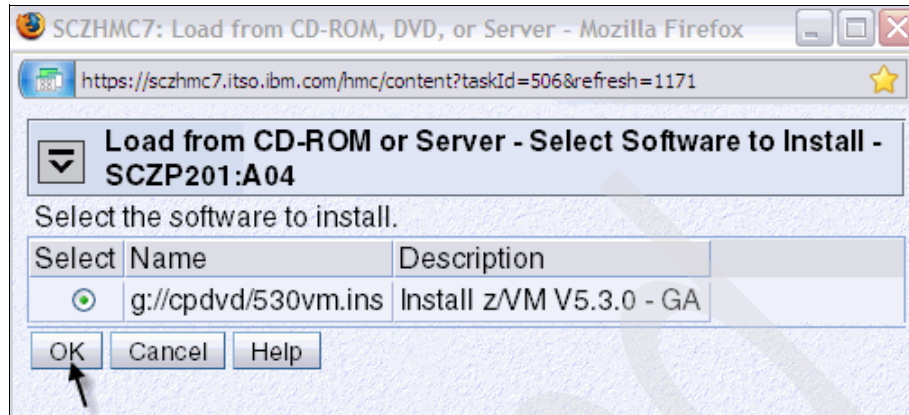

Figure 4-10 Selecting z/VM 5.3 ramdisk system

- b. In the “Confirm the action” window, click **Yes**. You should see the “Load from CD-ROM, DVD or Server Progress” window. The green light on the DVD drive should light up.
- c. When you see the message **Completed successfully**, click **OK** to close. This usually takes about four to six minutes.

**Attention:** Although the z/VM ramdisk (IBMV MRAM) loads in about four to six minutes, slow load times have been observed (15-18 minutes). When the green light on the DVD drive is solid, the load time is acceptable. When it is intermittently dark more than it is green, long load times can result.

You should now have an in-memory z/VM 5.3 system running. The tasks performed in this section are similar to loading a Linux kernel onto memory for installation. You can compare this section with section 4.4.2, “Booting the Linux kernel for installation” on page 199 and later verify that both those systems load an image to main memory before the installation commences. One difference is that Linux starts the installation program automatically, whereas in z/VM you must invoke a command as stated in the next section.

## Copying a z/VM system image to DASD

To copy z/VM to DASD:

1. Get out of Single Object Operations mode by logging off the primary SE window by closing that window.
2. Use the Alt+Tab sequence to move to the Integrated 3270 console window. The ramdisk IPLs and the system come up with the MAINT user ID logged on. You should see z/VM boot as shown in Figure 4-11 on page 150.

```
SCZHMC7: Integrated 3270 Console for SCZP201:A04
File Keys Font Help

09:38:21
09:38:21 *****
09:38:21 * LICENSED MATERIALS - PROPERTY OF IBM*
09:38:21 *
09:38:21 * 5741-A05 (C) COPYRIGHT IBM CORP. 1983, 2007. ALL RIGHTS
09:38:21 * RESERVED. US GOVERNMENT USERS RESTRICTED RIGHTS - USE,
09:38:21 * DUPLICATION OR DISCLOSURE RESTRICTED BY GSA ADP SCHEDULE
09:38:21 * CONTRACT WITH IBM CORP.
09:38:21 *
09:38:21 * * TRADEMARK OF INTERNATIONAL BUSINESS MACHINES.
09:38:21 *****
09:38:21

09:38:21 The directory on volume $RAMD$ at address FFFF has been broug

09:38:21 No dump unit - Dump function is SET OFF
09:38:21 HCPAAU2700I System gateway IBMVMRAM identified.
09:38:22 z/VM Version 5 Release 3.0, Service Level 0000 (64-bit),
09:38:22 built on IBM Virtualization Technology
09:38:22 There is no logmsg data
09:38:22 FILES: NO RDR, NO PRT, NO PUN
09:38:22 LOGON AT 09:38:22 EDT THURSDAY 06/26/08
09:38:22 SYSG LOGON AS MAINT USERS = 1
09:38:22 HCPIOP952I 4G system storage
09:38:22 FILES: 0000001 RDR, 0000001 PRT, NO PUN
09:38:22 HCPCRC8082I Accounting records are accumulating for userid OI
09:38:22 HCPCRC8082I EREP records are accumulating for userid OPEREREH
DMSIND2015W Unable to access the Y-disk. Filemode Y (19E) not access
DMSWSP327I The installation saved segment could not be loaded
z/VM V5.3.0 2007-05-04 13:22
DMSDCS1083E Saved segment CMSPIPES does not exist
DMSDCS1083E Saved segment CMSPIPES does not exist
DMSDCS1083E Saved segment CMSVMLIB does not exist
Ready; T=0.01/0.01 09:38:22

RUNNING IBMVMF
```

Figure 4-11 z/VM first boot on Integrated console

- Invoke the INSTPLAN command., which will allow you to select associated z/VM products to install, the language to use, and the type of DASD on which to install:

==> instplan

The display shown in Figure 4-12 opens. Do not delete or modify any letter “M” in the Install To columns. This letter signifies that each product you selected will be installed onto minidisks.

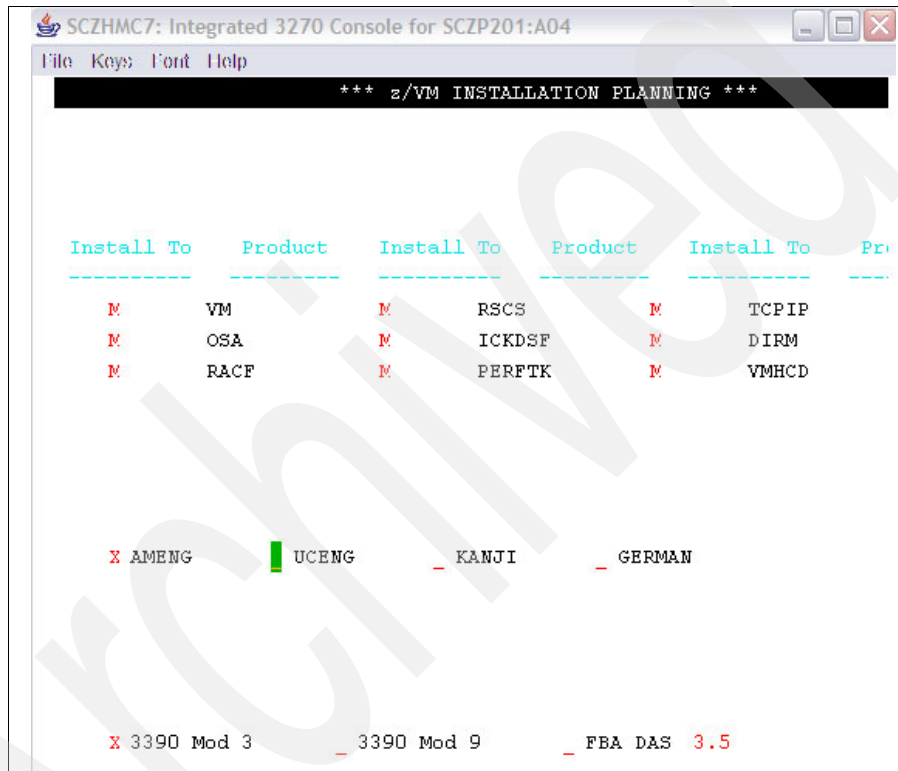

Figure 4-12 Installation Planning menu

- Type the letter X next to AMENG (or select your language) and next to 3390 Mod 3 (or select the type of DASD you will use).
- Press F5. The following message is displayed:  
HCPINP8392I INSTPLAN EXEC ENDED SUCCESSFULLY
- Attach the DASD devices onto which z/VM will be installed defined in your planning worksheet (from Appendix B, “Planning worksheet” on page 403).

In the following example, the our devices are 1A20-1A24 (use your own values and do not type the angle brackets):

```
==> att <1a20-1a24> *  
1a20-1a24 ATTACHED TO MAINT
```

**Important:** The angle brackets (<>) in our examples throughout the book mean that you should replace the our example values with the correct values for your site. For instance, if you are installing z/VM onto DASD 1200-1204, you would type the following:

```
==> att 1a00-1a04 *
```

## Running INSTDVD

The INSTDVD EXEC copies the z/VM system from DVD to disk. To run INSTDVD:

1. Execute the INSTDVD EXEC command:

```
==> instdvd
```

If you are using 3390-3s, a panel requests the five volumes (Figure 4-13).

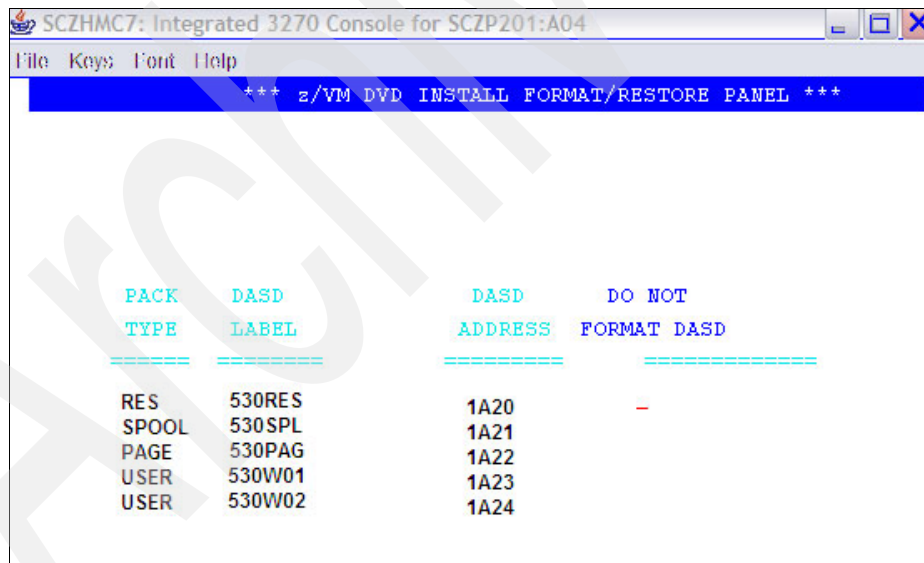

Figure 4-13 The instdvd DASD window

- a. Enter the addresses of the five volumes on which z/VM will be installed.
- b. Do *not* select the DO NOT FORMAT DASD check box on the right side of the panel.



- c. Notice that you can change the labels of all volumes except 530RES. We suggest that you change the other labels to something other than 530. Section 4.3.3, “Relabeling the system volumes” on page 165 explains why you should change the labels. We changed ours to use the prefix LX6.
  - d. Press F5 to start the installation.
2. Type Y (yes) when you are prompted to continue (DO YOU WANT TO CONTINUE?) .  
The message NOW FORMATTING DASD <1A20> is displayed.

**Important:** INSTDVD on a z10 LPAR took us about an hour.

Read errors might occur, resulting in INSTDVD failing. If this happens, try using the following command so the installation process can continue where the read error occurred:

```
INSTDVD (RESTART
```

Read errors can be caused by dirt or fingerprints on the DVD.

3. You are prompted to place the system RSU in the drive. Insert the “z/VM Stacked Recommended Service Upgrade 5301” DVD into the HMC DVD-ROM drive and type GO. This step takes two to four minutes.

The following message, or a similar one, is displayed:

```
DVDLOAD: LOADING FILE CKD5000x IMAGE *
```

When the process completes, the following message is displayed:

```
HCPIDV8329I INSTDVD EXEC ENDED SUCCESSFULLY.
```

### **IPL z/VM from DASD**

To IPL your initial z/VM system on DASD:

1. From the HMC, select your LPAR by clicking it. You might have to first double-click **Groups**.  
The CPC Recovery (also sometimes named Recovery) menu opens.
2. Double-click the **Load** icon in the menu at the right side. The Load panel opens as shown in Figure 4-14 on page 154.

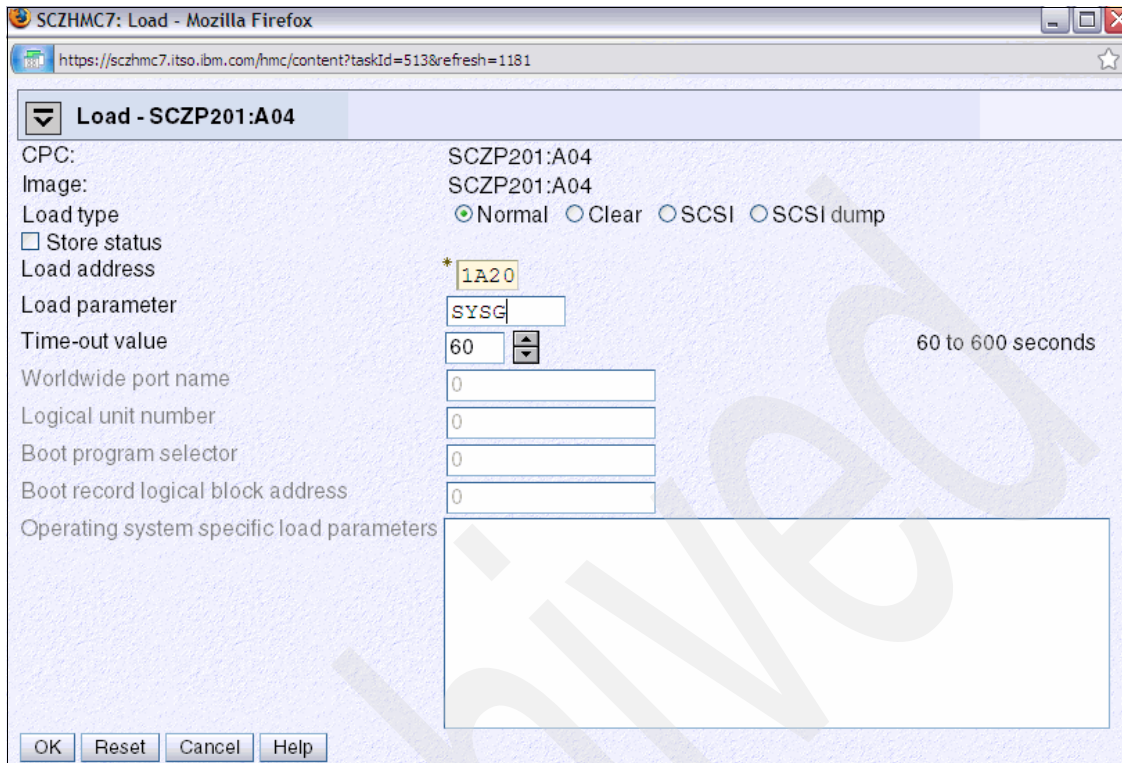

Figure 4-14 Load panel

3. Follow these steps:
  - a. For the load type, select the **Clear** button.
  - b. Set the load address to be the new system residence (530RES) volume, which is <1A20> in this example.
  - c. Set the load parameter to SYSG. This specifies to use the Integrated 3270 console.
  - d. Click **OK** to load.
4. When the Load Task Confirmation window opens, click **Yes**.
5. After approximately 1-3 minutes, when the word Success appears in the Load Program window, click **OK**.
6. Use the Alt+Tab sequence to move back to the Integrated 3270 console window. The STAND ALONE PROGRAM LOADER panel opens.

- a. Press the Tab key to traverse to the IPL Parameters section, as shown in Figure 4-15, and enter the value `cons=sysg`. This specifies the use of Integrated 3270 console.

```
STAND ALONE PROGRAM LOADER: z/VM VERSION 5 RELEASE 3.0

DEVICE NUMBER:  1A20          MINIDISK OFFSET: 00000000 EXTENT:1

MODULE NAME:    CLOAD        LOAD ORIGIN:    2000

-----IPL PARAMETERS-----
cons=sysg
-----COMMENTS-----
-----
```

Figure 4-15 IPL parameters.

- b. Press the F10 key to continue the IPL of your z/VM system. This can be approximately 2-3 minutes.
7. At the Start (Warm|Force|COLD|CLEAN) prompt, enter the following command:  
==> `cold drain noautolog`
8. At the Change TOD clock prompt enter:  
==> `no`  
The last message is:  
HCPCRC8082I EREP records are accumulating for userID EREP
9. Disconnect from the OPERATOR user ID by using the DISCONNECT command (or its abbreviated form: DISC):  
==> `disc`
10. Press Enter to open a new logon window.

## Completing the z/VM installation

To complete the z/VM installation:

1. On the z/VM login window, log on as MAINT. The password is MAINT. You might receive messages HCPLMN108E or DMSACP113S about disks not linked or attached. This is not a problem. Press Enter when you see the VM Read prompt in the lower right corner.

**Important:** When logging on to a z/VM user ID that runs CMS, press Enter at the VM READ prompt. This results in a prompt of the form:

```
Ready; T=0.01/0.01 11:14:20
```

2. Issue the **ipl cms** command and then press Enter, as indicated. The Ready; prompt appears.

```
==> ipl cms  
==> (Press the Enter key)  
Ready;
```

3. Run the INSTVM DVD command:

```
==> instvm dvd  
...  
HCPPLD8329I POSTLOAD EXEC ENDED SUCCESSFULLY  
...  
HCPIVM8392I INSTVM ENDED SUCCESSFULLY
```

The EXEC continues the installation process. This step takes about 4-8 minutes. The last message is:

```
HCPIVM8392I INSTVM ENDED SUCCESSFULLY
```

4. Load the recommended service. For z/VM 5.3, the service name is 5301RSU1. Run the following commands:

```
==> ipl cms  
==> Press Enter  
Ready;  
==> acc 500 c  
DMSACC724I 500 replaces C (2CC)  
==> listfile * * c  
5301RSU1 SERVLINK C1  
==> service all 5301rsu1
```

This step takes about 3-6 minutes. The last message is:

```
VMFSRV2760I SERVICE processing completed successfully
```

5. IPL CMS and run the PUT2PROD command. This puts the service into production:

```
==> ipl cms  
==> Press Enter  
Ready;  
==> put2prod
```

This step takes about 2-4 minutes. The last message is:

```
VMFP2P2760I PUT2PROD processing completed successfully
```

A return code of 0 is ideal. You might receive a return code of 4 and the message:

```
VMFP2P2760I PUT2PROD process completed with warnings
```

In general on z/VM, a return code of 4 is acceptable. That means that only warnings were issued. A return code of 8 or greater generally means that errors were encountered.

6. Enter the following command to shutdown and IPL your system again:

```
==> shutdown reipl  
SYSTEM SHUTDOWN STARTED
```

Although you lose your 3270 session, the system returns in about 2-4 minutes. After it does, the last message is:

```
Press enter or clear key to continue
```

7. Press Enter. The z/VM logon window opens.

Congratulations! You now have a vanilla z/VM system installed.

### **Configuring the PROFILE XEDIT file**

When invoked, the XEDIT command looks for the file PROFILE XEDIT configuration file. Many z/VM user IDs do not have such a personal or shared system file, so all XEDIT default values are in effect. The MAINT 191 (A) disk has a PROFILE XEDIT file, so when you are editing files on MAINT, the values in this profile are usually in effect.

To have a good experience while using XEDIT, make the profile for the MAINT user be similar to the one in Example 2-25 on page 92. To do this, log on to MAINT and edit the file with XEDIT itself:

```
==> xedit profile xedit a
```

Save your changes with the XEDIT subcommand SAVE.

**Important:** One default setting that can be dangerous, especially if you use F12 to retrieve commands, is when PF12 is set to the FILE subcommand. Sometimes you might not want to save your changes with the stroke of one key. It is recommended that you set PF12 to the ? subcommand, which has the effect of a retrieve key:

```
==> x profile xedit a
```

**Before:** SET PF12 FILE

**After:** SET PF12 ?

Save your changes now and exit by using the FILE subcommand.

## Configuring TCP/IP

The recommendation is that you initially configure TCP/IP in your z/VM environment with the IPWIZARD command the first time you configure TCP/IP in your z/VM environment and then manually change the configuration files thereafter. After IPWIZARD creates the initial configuration files, you maintain them manually.

### *Logging on to MAINT*

In the z/VM logon panel, log on to MAINT. The default password for all z/VM user IDs is the same as the user ID. Enter a password of `maint`, which is not echoed in the window.

```
USERID ==> maint  
PASSWORD ==>
```

After entering the user ID and password, press Enter when the status area in the lower right indicates VM READ.

### *Using the IPWIZARD tool*

The IPWIZARD command is on the MAINT 193 disk. To pick up IPWIZARD from that minidisk, access it in file mode G with the ACCESS:.

1. Access the MAINT 193 disk:

```
==> acc 193 g
```

2. Invoke IPWIZARD:

```
==> ipwizard
```

The z/VM TCP/IP Configuration Wizard opens; The first field, User ID, should always be TCP/IP:

\*\*\* z/VM TCP/IP Configuration Wizard \*\*\*

The items that follow describe your z/VM host

User ID of VM TCP/IP Stack Virtual Machine: **TCPIP**\_\_

Host Name: **<vm linux6>**\_\_\_\_\_

Domain Name: **<itso.ibm.com>**\_\_\_\_\_

Gateway IP Address: **<9.12.4.1>**\_\_\_\_\_

DNS Addresses:

1) **<9.12.6.7>**\_

2) \_\_\_\_\_

3. Obtain the remaining values from the “The planning worksheets” on page 143 and press F8. The General Interface Configuration Panel opens:

\*\*\* General Interface Configuration Panel \*\*\*

Interface Name: **ETH0**\_\_\_\_\_ Device Number: **<3020>**

IP Address: **<9.12.4.89>**\_

Subnet Mask: **<255.255.252.0>**\_\_

Interface Type (Select one):

QDIO       LCS       HiperSockets

Note the following information about this panel:

- ETH0 is the Interface Name. This is arbitrary but is recommended.
  - The Device Number is the starting address of the OSA triplet that the z/VM stack will use.
  - The IP Address, which must be routed to the OSA card will become the TCP/IP address of the z/VM system.
  - The Interface Type is typically QDIO with modern OSA devices.
4. Press F8 when you finish. The QDIO Interface Configuration Panel opens:

\*\*\* QDIO Interface Configuration Panel \*\*\*

Network Type (Select one):

Ethernet                     Token Ring

Port Name (optional): \_\_\_\_\_

Router Type (Select one):

Primary                     Secondary                     None

Note the following information about this panel:

- In general, a value for the Port Name is no longer necessary<sup>7</sup>.
- A Router Type of None is recommended.

5. Press F5 to complete the wizard. The following message is displayed:

```
DTCIPW2508I DTCIPWIZ EXEC is attempting to create the necessary
DTCIPW2508I configuration files
```

6. In the following message, type 1 to restart the TCP/IP stack:

```
The TCP/IP stack (TCPIP) must be restarted as part of this procedure
Would you like to restart and continue?
```

```
Enter 0 (No), 1 (Yes) 1
```

```
USER DSC LOGOFF AS TCPIP USERS = 2 FORCED BY MAINT
```

```
...
```

```
Successfully PINGed Interface (9.12.4.89)
```

```
Successfully PINGed Gateway (9.12.4.1)
```

```
Ping Level 520: Pinging host 9.12.6.7
```

```
Enter 'HX' followed by 'BEGIN' to interrupt.
```

**Important:** If the DNS server cannot be pinged, enter 1 to try it again:

```
PING: Ping #1 timed out
```

```
Not all of the PINGs were successful. Would you like
to try them again?
```

```
Enter 0 (No), 1 (Yes)
```

```
==> 1
```

```
...
```

<sup>7</sup> If the OSA card already has a port number defined, for example because it is being shared by a system that requires a port number, then you should set the same port number here.



7. Watch for the message IPWIZARD EXEC ENDED SUCCESSFULLY:

```
...  
Successfully PINGed Interface (9.12.4.89)  
Successfully PINGed Gateway (9.12.4.1)  
Successfully PINGed DNS (9.12.6.7)  
DTCIPW2519I Configuration complete; connectivity has been verified  
DTCIPW2520I File PROFILE TCPIP created on TCPIP 198  
DTCIPW2520I File TCPIP DATA created on TCPIP 592  
DTCIPW2520I File SYSTEM DTCPARMS created on TCPIP 198  
HCPINP8392I IPWIZARD EXEC ENDED SUCCESSFULLY  
DMSVML2061I TCPIP 592 released
```

At this point your z/VM TCP/IP stack should be up and you can **ping** it from another system.

8. If the IPWIZARD fails, you must continue debugging it until it succeeds. Double check all values. Verify that the TCP/IP network and OSA information you were given are properly associated.

At this point z/VM should be accessible over the network.

**HMC Integrated 3270 Console or 3270 emulator?** You may continue working at the HMC, or you can access your new system with a 3270 emulator.

If you want to switch to 3270 emulator, use one of the following commands to log off MAINT:

- ▶ LOGOFF (abbreviated form is LOG or log): Ends your session.
- ▶ DISCONNECT: Your session remains open where it is and is resumed when you log back on.

In general, you should LOGOFF of system administration user IDs such as MAINT. However, you should always DISCONNECT from z/VM service machines such as TCPIP and user IDs running Linux. Logging off of them will terminate the service or crash Linux.

### Configuring TCP/IP to start at IPL time

Bringing the TCP/IP stack automatically online during the system IPL is accomplished by including statements in AUTOLOG1's PROFILE EXEC file. As you might recall the discussion in "The AUTOLOG1 user" on page 128, this user is responsible for bringing other virtual machines online.

To configure TCP/IP to start at IPL time:

1. Log off of MAINT.

==> log

A new logon panel opens.

2. Log on to AUTOLOG1. Again the password is the same as the user ID.
3. At the VM READ prompt enter **ACCESS (NOPROF** to prevent PROFILE EXEC from running:

**LOGON AUTOLOG1**

z/VM Version 5 Release 3.0, Service Level 0701 (64-bit),  
built on IBM Virtualization Technology

There is no logmsg data

FILES: NO RDR, NO PRT, NO PUN

LOGON AT 13:30:12 EST THURSDAY 11/29/07

DMSIND2015W Unable to access the Y-disk. Filemode Y (19E) not accessed

z/VM V5.3.0 2007-11-24 12:48

**acc (noprof**

4. Copy the PROFILE XEDIT from the MAINT 191 disk so XEDIT sessions will have a common interface among user IDs.

- a. Use the **VMLINK** command to both link to the read-only disk and to access it at the highest available file mode. The default read password is **read**:

==> **vmlink maint 191**

ENTER READ PASSWORD:

read

DMSVML2060I MAINT 191 linked as 0120 file mode Z

- b. Copy the PROFILE XEDIT to your A disk:

==> copy profile xedit z = = a

5. Make a backup copy of the PROFILE EXEC and run the editor to edit it:

==> copy profile exec a = execorig =

==> x profile exec

The text in Example 4-2 appears.

*Example 4-2 The text before you modify it*

---

```
/*  
/* Autolog1 Profile Exec */  
/*
```

Address Command

'CP XAUTOLOG VMSERVS'

'CP XAUTOLOG VMSERVU'

'CP XAUTOLOG VMSERVR'

---

6. Modify it as follows and see the results in Example 4-3 on page 163.

- a. The z/VM Shared File System (SFS), is not required to run Linux so you can safely delete the three XAUTOLOG lines for the user IDs VMSESRVS, VMSESRVR and VMSESRVU.
- b. You can also safely delete the Address Command line.
- c. Add a line to start the TCPIP user ID with the XAUTOLOG command, and retain any statements that start the VSWITCH controllers.
- d. Add a line to LOGOFF of AUTOLOG1 when the EXEC is complete. There is no need to keep that virtual machine running because its sole purpose is to run the PROFILE EXEC.

*Example 4-3 The text **after** you modify it*

---

```

/*****/
/*  Autolog1 Profile Exec  */
/*****/

'cp xautolog tcpip'          /* start up TCPIP */
'cp logoff'                  /* logoff when done */

```

---

7. Save your changes with the FILE subcommand and use LOGOFF to log off AUTOLOG1:

```

====> file
==> log

```

When your z/VM system IPLs, the TCP/IP stack will come up automatically (if you do *not* specify the notautolog parameter at IPL time).

## Setting up an FTP server

In this section, you learn how to set up an FTP server for your z/VM because, in the section “Getting the files required for Linux boot” on page 188, you have to send files from your workstation to your Linux guest virtual machine. The files must keep their 80-character record length property.

By default, z/VM has an FTP server included in its installation. To bring it online, log on as TCPMAINT and edit the PROFILE TCPIP file on its 198 disk, which is accessed as the D disk:

```

==> x profile tcpip d

```

The file before you edit it is shown in Example 4-4.

*Example 4-4 The file **before** editing it*

---

```

; -----
OBEY
OPERATOR TCPMAINT MAINT MPROUTE ROUTED DHCPD REXECD SNMPD SNMPQE
ENDOBEY

```

```

; -----
PORT
; 20 TCP FTPSERVE NOAUTOLOG ; FTP Server
; 21 TCP FTPSERVE           ; FTP Server
; 23 TCP INTCLIEN           ; TELNET Server
; 25 TCP SMTP               ; SMTP Server
...

```

---

Add an AUTOLOG statement near the top of the file; FTPSERVE should be the only entry. In the PORT statement, remove the semicolons to uncomment the lines containing FTPSERVE (ports 20 and 21). These changes cause the FTP server to start when TCP/IP is started. Then, save your changes with the FILE subcommand. See Example 4-5.

*Example 4-5 The file **after** editing it*

```

; -----
OBEY
OPERATOR TCPMAINT MAINT MPROUTE ROUTED DHCPD REXECD SNMPD SNMPQE
ENDOBEY
; -----
AUTOLOG
  FTPSERVE 0
ENDAUTOLOG

PORT
  20 TCP FTPSERVE NOAUTOLOG ; FTP Server
  21 TCP FTPSERVE           ; FTP Server
  23 TCP INTCLIEN           ; TELNET Server
; 25 TCP SMTP               ; SMTP Server
...
====> file

```

---

These changes will take effect after you IPL you system again.

### **IPL the system again (re-IPL)**

You might want to shut down and re-IPL z/VM without having to access the HMC. Often, the HMC is logged off and thus the Integrated 3270 console (SYSG) is not available. Because of these factors, it is useful to use the System Console (SYSC), which has a title of Operating System Messages on the HMC, to be able to shut down z/VM and re-IPL it without having to use the console. This console is always accessible whether you are logged on to the HMC or not. z/VM messages during both the shutdown and re-IPL processes are written to the system console, but often you can ignore them; you simply want your system back in a few minutes over the network.

You may now shut down and re-IPL the system. It is the fastest way to put the previous changes into effect because no production systems are running yet. Pass the parameter IPLPARMS CONS=SYSC to the SHUTDOWN REPI command:

```
==> shutdown reipl iplparms cons=sysc
```

You will lose your session, but it should come back in a few minutes.

If the network settings are correct, you can now access your z/VM through the network instead of using the HMC. You can use a 3270-like emulator, such as IBM Personal Communications, to access your network-enabled z/VM by its IP address.

### 4.3.3 Relabeling the system volumes

This step is optional, however, it is recommended. Sometimes you will want to change the volume labels of the five z/VM system volumes (or three if you installed onto multiple 3390-9s). In the event that another vanilla z/VM system with the same labels is installed onto volumes accessible by your z/VM system, one of the systems will not IPL correctly.

When installing z/VM, it is possible to modify all but one volume label, that of the 530RES volume. This alleviates the problem that is described next, but it does not alleviate the problem of duplicate volume names. To understand this possibility, refer to Figure 4-16.

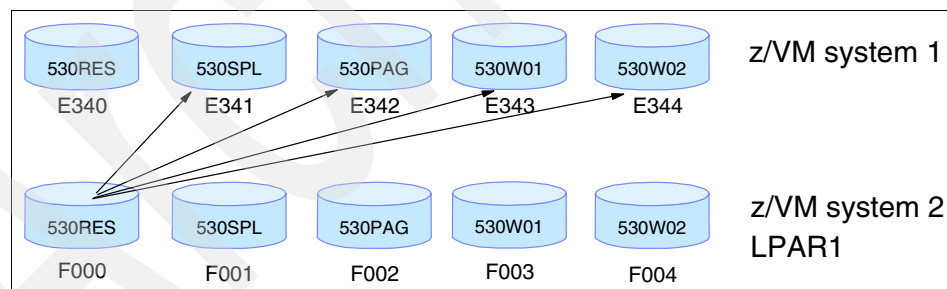

Figure 4-16 The problem with two z/VM systems with identical volume labels

The z/VM system with the lower device addresses starting at E340 should IPL fine (though you might see a warning at system startup time about duplicate volume labels). However, if the z/VM system starting at device address F000 is IPLed, the 530RES volume will be used, but the remaining volumes in the system are searched for by volume label, not by device address. Because z/VM system 1's addresses are lower than z/VM system 2's, system 2 will use system 1's volumes. This is not good for either system!

Linux systems that use label conventions to access their root partitions also suffer from a similar problem. If you install two Linux systems onto the same disk, both using labels to identify their partitions, the second system will actually use the first partition labelled as the root filesystem. Using labels in Linux is not recommended by the authors of this book.

If there is a possibility of another z/VM system being installed on DASD that this system will have access to, the recommendation is that you perform the steps in the following sections:

- ▶ “Modifying labels in the SYSTEM CONFIG file” on page 166
- ▶ “Modifying labels in the USER DIRECT file” on page 168
- ▶ “Changing the labels on the five volumes” on page 169
- ▶ “Shutting the system down and re-IPLing it” on page 170

You must have access to the HMC to perform the steps.

**Note:** This process must be done as documented. Making a mistake in one of the steps can easily result in an unusable system. Check your steps carefully and your system will come back with no problems. Try to do all steps in succession in a short amount of time. Close your door, do not answer your phone or e-mail, turn off instant messaging:))

## Modifying labels in the SYSTEM CONFIG file

This file controls what DASDs are used by the system, what virtual resources are defined and so on. Modify various DASD settings to allow the system to correctly start up with the new labels.

You must have an HMC 3270 session because z/VM will have to be restarted with a FORCE option.

To modify labels in the SYSTEM CONFIG file:

1. Start an Integrated 3270 Console session on the HMC from the CPC Recovery (or just Recovery) menu.
2. Note the first five CP-owned volumes by using the QUERY CPOWNER command:

```
==> q cpowned
```

Slot	Vol-ID	Rdev	Type	Status
1	530RES	A700	Own	Online and attached
2	LX6SPL	A701	Own	Online and attached
3	LX6PAG	A702	Own	Online and attached
4	LX6W01	A703	Own	Online and attached
5	LX6W02	A704	Own	Online and attached
6	MPA705	A705	Own	Online and attached

```

7 MPA706 A706 Own Online and attached
8 MPA707 A707 Own Online and attached
9 MPA708 A708 Own Online and attached
10 MPA709 A709 Own Online and attached
11 ----- ---- ----- Reserved
12 ----- ---- ----- Reserved
...

```

Because we had changed the labels for the other four DASDs in “Running INSTDVD” on page 152, only the 530RES DASD must have its label changed.

**For 3390-9s:** If z/VM is installed onto multiple 3390-9s, there should only be three system volumes:

```

==> q cpowned
Slot Vol-ID Rdev Type Status
1 530RES 9300 Own Online and attached
2 530SPL 9301 Own Online and attached
3 530PAG 9302 Own Online and attached
...

```

3. An XEDIT sub-command is used to help make this process more reliable. It can be used on both the SYSTEM CONFIG and USER DIRECT files. To modify the labels in the SYSTEM CONFIG file, release the A CP-disk and access it as read-write. Back up the SYSTEM CONFIG file:

```

==> cprelease a
CPRELEASE request for disk A scheduled.
HCPZAC6730I CPRELEASE request for disk A completed.
==> link * cf1 cf1 mr
==> acc cf1 f
==> copy system config f = confwrks = (oldd rep

```

4. Edit the SYSTEM CONFIG file and use the ch subcommand with each label you have to relabel (530RES only, in this example):

```

==> xedit system config f
==> ch /530RES/<LX6RES>/* *

```

**Note:** Do not forget to change <LX6RES> to whichever prefix you are using.

After each change command, a message indicates that lines have been changed.

5. Clear the window to return to editing the file in XEDIT. Search for the string cp\_owned and you should see the new labels. Be sure they are correct before saving the file with the FILE subcommand:

```

====> /cp_owned
/*                               CP_Owned Volume Statements                               */

```

```
/*****/
```

```
CP_Owned Slot 1 LX6RES  
CP_Owned Slot 2 LX6SPL  
CP_Owned Slot 3 LX6PAG  
CP_Owned Slot 4 LX6W01  
CP_Owned Slot 5 LX6W02
```

```
...
```

```
====> file
```

6. Verify are no syntax errors exist:

```
==> acc 193 g  
==> cpsyntax system config f  
CONFIGURATION FILE PROCESSING COMPLETE -- NO ERRORS ENCOUNTERED.
```

7. Release and detach the F disk, and use CPACCESS (or its abbreviation: CPACC) access the A disk and verify:

```
==> rel f (det  
DASD OCF1 DETACHED  
==> cpacc * cf1 a  
CPACCESS request for mode A scheduled.  
Ready; T=0.01/0.01 09:19:57  
HCPZAC6732I CPACCESS request for MAINT's OCF1 in mode A completed.  
==> q cpdisk
```

Label	Userid	Vdev	Mode	Stat	Vol-ID	Rdev	Type	StartLoc	EndLoc
MNTCF1	MAINT	OCF1	A	R/O	530RES	A700	CKD	39	83
MNTCF2	MAINT	OCF2	B	R/O	530RES	A700	CKD	84	128
MNTCF3	MAINT	OCF3	C	R/O	530RES	A700	CKD	129	188

You have now changed the labels of the system volumes in the SYSTEM CONFIG file.

**Important:** It is critical that you proceed because your system is now in a state in which it will not IPL cleanly.

## Modifying labels in the USER DIRECT file

The USER DIRECT file stores information about the space used by each z/VM virtual machine, that is, each user. The changes made to DASD labels must be reflected in the file also, or your system will ultimately be in an inconsistent state.

To modify the USER DIRECT file again:

1. Use XEDIT's **ch** subcommand. You should begin to see many more occurrences of the labels being changed:

```
==> copy user direct c = direwrks = (oldd rep  
==> x user direct c
```



```
====> ch /530RES/<LX6RES>/* *
DMSXCG517I 84 occurrence(s) changed on 84 line(s)
```

You may choose to traverse the file to verify it before saving the changes.

2. Use the FILE subcommand to save the file:

```
====> file
```

You have now changed the labels of the system volumes in the USER DIRECT and SYSTEM CONFIG files. Again, it is critical that you proceed with the remaining steps.

## Changing the labels on the five volumes

To relabel a pack, use write access to cylinder 0 of the DASD volume. There are already mdisk statements that give you that access. To change the labels on the five volumes:

1. Query the disks to make sure you have R/W access to them:

```
query virtual 122-125
```

```
DASD 0122 3390 LX6SPL R/W 3339 CYL ON DASD 1A21 SUBCHANNEL = 000A
DASD 0123 3390 530RES R/W 3339 CYL ON DASD 1A20 SUBCHANNEL = 000B
DASD 0124 3390 LX6W01 R/W 3339 CYL ON DASD 1A23 SUBCHANNEL = 000C
DASD 0125 3390 LX6W02 R/W 3339 CYL ON DASD 1A24 SUBCHANNEL = 000D
```

**Note:** The mapping of virtual addresses and volumes defaults as:

- ▶ MAINT 122 for 530SPL
- ▶ MAINT 123 for 530RES
- ▶ MAINT 124 for 530W01
- ▶ MAINT 125 for 530w02
- ▶ \$PAGE\$ A03 for 530PAG

You might have to link to the paging minidisk before querying it, if you also have to relabel it (which is not the case of our example installation because it is already correctly labelled):

```
link $page$ a03 a03 mr
```

```
Ready; T=0.01/0.01 17:24:51
```

```
query virtual a03
```

```
DASD 0A03 3390 LX6PAG R/W 3339 CYL ON DASD 1A22 SUBCHANNEL = 004A
```

2. Use the following command to relabel each of the packs with the appropriate new label:

```
cpfmtxa 123 <LX6RES> label
```

**Note:** On the command, make sure you add the last parameter, label.

The z/VM system does not reread the pack labels until the next IPL, so if you were to display these packs, the old labels will be displayed.

3. Load the updated USER DIRECT file to the system directory space.

```
directxa user direct c
```

4. After the new directory is loaded, shut down and re-IPL the system.

### Shutting the system down and re-IPLing it

You must be running an HMC console session for this step, if you are not already running from there.

Testing the changes involves shutting down and restarting your system. In this situation, you must not use SHUTDOWN REIPL because you will have to then use FORCE to restart it. To shut down the system, use the SHUTDOWN command alone:

```
==> shutdown
```

```
SYSTEM SHUTDOWN STARTED
```

```
HCPSHU960I System shutdown may be delayed for up to 210 seconds
```

To bring the system back up:

1. From the HMC, click the LOAD icon in the CPC Recovery (or just Recovery) menu.
2. Select the **Clear** radio button. All other parameters should be correct from the previous IPL. Click **OK**.
3. Click **Yes** on the Load Task Confirmation panel.
4. Go back to the Integrated 3270 console. After a few minutes, the Standalone Program Loader panel should open. Use the TAB key to traverse to the IPL Parameters section and enter the following value:

```
cons=sysg
```

5. Press the F10 key to continue the IPL of your z/VM system. This takes around three minutes.
6. At the Start prompt, specify a FORCE start because the spool volume label has changed:

```
==> force drain
```

7. Do not change the time of day clock:

```
==> no
```

8. When the IPL completes, DISCONNECT from the OPERATOR user ID:

```
==> disc
```

9. Log on to MAINT.

You should now be able to start a 3270 emulator session because the TCP/IP service machine should be up. Get a 3270 session as MAINT and verify the volume labels have changed by using the QUERY CPOWNER command:

```
==> q cpowered
```

Slot	Vol-ID	Rdev	Type	Status
1	LX6RES	1A20	Own	Online and attached
2	LX6SPL	1A21	Own	Online and attached
3	LX6PAG	1A22	Own	Online and attached
4	LX6W01	1A23	Own	Online and attached
5	LX6W02	1A24	Own	Online and attached
...				

If you IPLed a system with duplicate system volumes, you might have possibly destroyed your saved segments. You know this is the case when you cannot IPL CMS so you will have to IPL 190.

**Important:** Only do this if your saved segments have been destroyed! To rebuild saved segments, try the following commands, as MAINT:

```
==> vmfsetup zvm cms
==> sampnss cms
==> i 190 cl parm savesys cms
```

```
==> vmfbld ppf segbld esasegs segblist ( all
```

## 4.4 Installing Linux

This section describes configuring your z/VM system to install Linux, booting the Linux kernel for installation, and logging into the Linux system.

### 4.4.1 Configuring your z/VM system for installing Linux

Having a simple but efficient environment to run Linux virtual machines on z/VM requires that you first configure and customize your environment so that resources such as DASDs, networking and easy-to-manage-and-install Linux guests are all available at the time you execute the Linux kernel.

The configuration tasks involved are:

- ▶ Customizing the SYSTEM CONFIG file
  - Change various parameters.
  - Create a virtual switch.
- ▶ Setting up the DASDs for the Linux guest
  - Format the DASDs.
  - Configure DASDs for use by the system and user.
- ▶ Creating the Linux maintenance user
  - Create minidisks.
  - Set up a common environment for booting Linux in guest virtual machines.

Recall section 4.2.2, “System files” on page 126 where we mentioned important configuration files of z/VM. You are about to customize them now.

### Customizing the SYSTEM CONFIG file

The first configuration file read when z/VM IPLs is the SYSTEM CONFIG file. The following changes are recommended:

- ▶ Increase retrieve key capacity.
- ▶ Allow virtual disks (VDISKS) to be created
- ▶ Turn off the Disconnect Timeout. This will prevent idle disconnected users from being forced off the system.
- ▶ Define a virtual switch (VSWITCH) that will be used for Linux networking.

Defining a virtual switch for all of the Linux guest systems is good practice because you will probably not have enough physical OSA network cards for every guest virtual machine that you create if you are plan to increase the amount later. A virtual switch uses a single real OSA device and shares network connectivity among multiple virtual guests.

To customize the SYSTEM CONFIG file:

1. Release the CF1 disk.

To edit the SYSTEM CONFIG file, the MAINT CF1 minidisk must be released as a CP disk via the CPRELEASE (or its abbreviation: CPREL) command. The CP disks are queried with the QUERY CPDISK command. Note that, because the *CF1* disk is owned by CP, it is being accessed in read-only mode by MAINT as CP disk A. Therefore, to access that CF1 disk in multi-read mode, we first request CP to release it, and then access it in multi-read (mr) mode:

```
==> q cpdisk
```

```
Label  Userid  Vdev Mode Stat Vol-ID Rdev Type  StartLoc  EndLoc
```

```

MNTCF1 MAINT   OCF1  A   R/O  MVA740 A740 CKD      39      158
MNTCF2 MAINT   OCF2  B   R/O  MVA740 A740 CKD      159     278
MNTCF3 MAINT   OCF3  C   R/O  MVA740 A740 CKD      279     398

```

```
==> cprel a
```

CPRELEASE request for disk A scheduled.

HCPZAC6730I CPRELEASE request for disk A completed.

```
==> q cpdisk
```

```

Label Userid  Vdev Mode Stat Vol-ID Rdev Type  StartLoc  EndLoc
MNTCF2 MAINT   OCF2  B   R/O  MVA740 A740 CKD      159     278
MNTCF3 MAINT   OCF3  C   R/O  MVA740 A740 CKD      279     398

```

2. After it is released, access the MAINT CF1 disk in read-write mode. Use the LINK command with multi-read (MR) parameter, and the ACCESS command to get read-write access to the minidisk.

```
==> link * cf1 cf1 mr
```

```
==> acc cf1 f
```

3. Now the MAINT CF1 disk is accessed read-write as your F disk:

- a. First make a backup copy of the vanilla SYSTEM CONFIG file using the COPYFILE command with the OLDDATE parameter to prevent modification of the file's time stamp, then edit the original copy:

```
==> copy system config f system conforig f (oldd
```

```
==> x system config f
```

- b. Next look for the Features statement. You can search for it again or you can use F8 to page down. The following changes and additions are recommended:

- Increase the number of commands that can be retrieved from 20 to 99.
- Set the Disconnect\_Timeout to off so disconnected users do not get forced off.
- Allow unlimited VDISKS to be created by users by changing Userlim to **infinite** and by adding the **Syslim infinite** clause:

```

Features ,
  Disable ,                               /*Disable the following features*/
  Set_Privclass ,                         /*Disallow SET PRIVCLASS command*/
  Auto_Warm_IPL ,                         /*Prompt at IPL always */
  Clear_TDisk ,                           /*Don't clear TDisk at IPL time*/
Retrieve ,                                /*Retrieve options */
  Default 99 ,                             /*Default.... default is 20 */
  Maximum 255 ,                           /*Maximum.... default is 255 */
MaxUsers noLimit ,                       /*No limit on number of users */
Passwords_on_Cmnds ,                     /*What commands allow passwords?*/
  Autolog yes ,                           /*... AUTOLOG does */
  Link yes ,                               /*... LINK does */
  Logon yes ,                              /*... and LOGON does, too */
Disconnect_Timeout off ,                 /*Don't force disconnected users*/
Vdisk ,                                  /*Allow VDISKS for Linux swaps */

```

```
Syslim infinite ,
Userlim infinite
```

**Note:** If you want to limit the number of VDISKS users can create, pick a limit for it instead of using `infinite`. Read more about VDISKS in “Virtual DASD (VDISK)” on page 264.

4. Define a VSWITCH:

Use the `BOTTOM` (or its abbreviation `BOT`) subcommand to go to the bottom of the file. Add lines (you can use the `XEDIT ADD` subcommand, `a3`, to add three lines). Define a `VSWITCH` and set the `MAC` address prefix. If you have multiple `z/VM` systems, each should have a unique prefix. Modify the two starting addresses of the `OSA` triplets (3024 and 3028 in this example) to those you specified in “The planning worksheets” on page 143.

```
====> bot
====> a3
/* define vswitch named vsw1 and set MAC address prefixes to
02-00-01 */
define vswitch vsw1 rdev <3024> <3028>
vmlan macprefix 020001
```

5. Save your changes with the `XEDIT FILE` subcommand:

```
====> file
```

6. Test your changes with the `CPSYNTAX` command, which is on the `MAINT 193` disk:

```
==> acc 193 g
==> cpsyntax system config f
CONFIGURATION FILE PROCESSING COMPLETE -- NO ERRORS ENCOUNTERED.
Pay attention to the output. If you have any syntax errors, fix them before proceeding.
```

7. Release and detach the `MAINT CF1` disk with the `RELEASE` command (abbreviated as `REL`) and the `DETACH` parameter. Then put it back online with the `CPACCESS` command:

```
==> rel f (det
DASD OCF1 DETACHED
==> cpacc * cf1 a
CPACCESS request for mode A scheduled.
HCPZAC6732I CPACCESS request for MAINT's OCF1 in mode A completed.
```

```
==> q cpdisk
```

Label	Userid	Vdev	Mode	Stat	Vol-ID	Rdev	Type	StartLoc	EndLoc
<b>MNTCF1</b>	<b>MAINT</b>	<b>OCF1</b>	<b>A</b>	R/O	MVA740	A740	CKD	39	158
MNTCF2	MAINT	OCF2	B	R/O	MVA740	A740	CKD	159	278
MNTCF3	MAINT	OCF3	C	R/O	MVA740	A740	CKD	279	398

Note that all three CP disks are now accessed.

## Starting virtual switches automatically at system startup

As discussed in “Configuring TCP/IP to start at IPL time” on page 161, the AUTOLOG1 PROFILE EXEC is the best place to auto-start virtual resources during the system IPL. Therefore, the virtual switches should be started by that profile. In addition to that, the recommendation is to perform the following tasks by using AUTOLOG1s PROFILE EXEC:

- ▶ Configure Linux to shut down gracefully with the SET SIGNAL command.
- ▶ Overcommit memory with the SET SRM STORBUF command.
- ▶ Grant access to the VSWITCH for each Linux user.
- ▶ Limit minidisk cache in main storage and turn it off in expanded storage.

To accomplish the tasks and start the virtual switches at startup:

1. Logon to AUTOLOG1. At the VM READ prompt you have usually been pressing Enter which causes the PROFILE EXEC to be run. If you do not want this EXEC to run, enter the command ACCESS (NOPROF:

```
LOGON AUTOLOG1
z/VM Version 5 Release 3.0, Service Level 0701 (64-bit),
built on IBM Virtualization Technology
There is no logmsg data
FILES:  NO RDR,  NO PRT,  NO PUN
LOGON AT 13:39:10 EST SUNDAY 11/24/07
DMSIND2015W Unable to access the Y-disk. Filemode Y (19E) not accessed
z/VM V5.3.0  2007-11-10 09:57
==> acc (noprof
```

2. Make a copy of the working PROFILE EXEC

```
==> copy profile exec a = execwrks =
```

3. Edit the file and add the text, shown in boldface.

**Note:** You may choose to modify or omit some of these settings. You may also put the changes into the SYSTEM CONFIG file.

```
==> x profile exec
/*****/
/* Autolog1 Profile Exec */
/*****/
'cp xautolog tcpip'           /* start up TCP/IP */
'CP XAUTOLOG DTCVSW1'       /* start VSWITCH controller 1 */
'CP XAUTOLOG DTCVSW2'       /* start VSWITCH controller 2 */
'cp set pf12 ret'           /* set the retrieve key */
```

```
'cp set mdc stor 0m 128m'          /* Limit minidisk cache in CSTOR */
'cp set mdc xstore 0m 0m'         /* Disable minidisk cache in XSTOR */
'cp set srm storbuf 300% 250% 200%' /* Overcommit memory */
'cp set signal shutdown 180'     /* Allow guests 3 min to shut down */

'cp logoff'                       /* logoff when done */
```

4. Save your changes with the FILE subcommand.

**Important:** The set mdc and set srm lines are z/VM tuning values. These are likely good starts for Linux systems, but might not be optimal. To read more about these values see the following Web sites:

<http://www.vm.ibm.com/perf/tips/linuxper.html>  
<http://www.vm.ibm.com/perf/tips/prgmdcar.html>

Your system should now be configured to start up the virtual switches and send a signal to shut down Linux virtual machines gracefully.

## Verifying the changes

It is now time to make these changes take effect. You can do that by re-IPLing the system again or by issuing the commands you just placed into AUTOLOG1's profile. To re-IPL, pass the parameter IPLPARMS CONS=SYSC to the SHUTDOWN REIPL command:

```
==> shutdown reipl iplparms cons=sysc
```

Although you lose your session, it should be back up in several minutes. When it is back up, perform the following steps:

1. Start a 3270 session and Logon as MAINT.
2. Query the new VSWITCH:

```
==> q vswitch
VSWITCH SYSTEM VSW1      Type: VSWITCH Connected: 0      Maxconn: INFINITE
  PERSISTENT RESTRICTED  NONROUTER              Accounting: OFF
  VLAN Unaware
  State: Ready
  IPTimeout: 5           QueueStorage: 8
  Portname: UNASSIGNED RDEV: 3024 Controller: DTCVSW1 VDEV: 3024
  Portname: UNASSIGNED RDEV: 3028 Controller: DTCVSW2 VDEV: 3028 BACKUP
```

Verify that the VSWITCH exists and that there are two built-in VSWITCH controllers, DTCVSW1 and DTCVSW2. Before z/VM version 5.2, these user IDs had to be created manually.



3. Use the QUERY VDISK and QUERY RETRIEVE commands to see the changes made to the Features statement in the SYSTEM CONFIG file:

```
==> q retrieve
99 buffers available. Maximum of 255 buffers may be selected.
==> q vdisk userlim
VDISK USER LIMIT IS INFINITE
==> q vdisk syslim
VDISK SYSTEM LIMIT IS INFINITE, 0 BLK IN USE
```

This shows that the changes to the SYSTEM CONFIG file are in effect.

## Setting up DASDs

Setting up DASDs brings online those DASDs reserved for the Linux guest. Two steps are involved: formatting the DASDs and registering them into the system.

Format only the extra DASDs that you will use for system paging. The other DASDs intended to host the guest operating system (Linux) will be formatted by the guest operating system itself later.

### Formatting the DASDs

We format the DASDs we have planned to use as paging. This is done with the CPFMTXA command, which is an interactive program to format disks.

**z/OS analogy:** The analogous z/OS command for this would be to run a batch job executing the program ICKDSF using the appropriate parameters.

In Linux, the analogous command is `mkfs`.

To format the disks:

1. Use the ATTACH command (abbreviated as ATT) to attach the DASDs to our user space so that you can see them:  

```
att 8228 *
DASD 8228 ATTACHED TO MAINT 8228 WITH DEVCTL
```
2. Use the CPFMTXA command on each of the disks to format them. Remember to format them as PAGE volumes. Example 4-6 shows the interaction within the CPFMTXA command to format our PAGE DASD. User inputs are in boldface.
3. Repeat this process for every disk.

*Example 4-6 Formatting disks with cpfmtxa*

```
cpfmtxa
ENTER FORMAT, ALLOCATE, LABEL, OR QUIT:
```

**format**

ENTER THE VDEV TO BE PROCESSED OR QUIT:

**8228**

ENTER THE CYLINDER RANGE TO BE FORMATTED ON DISK 8228 OR QUIT:

**0-end**

ENTER THE VOLUME LABEL FOR DISK 8228:

**LX6PG2**

CPFMTXA:

FORMAT WILL ERASE CYLINDERS 00000-03338 ON DISK 8228

DO YOU WANT TO CONTINUE? (YES | NO)

**yes**

HCPCCF6209I INVOKING ICKDSF.

ICK030E DEFINE INPUT DEVICE: FN FT FM, "CONSOLE", OR "READER"

CONSOLE

ICK031E DEFINE OUTPUT DEVICE: FN FT FM, "CONSOLE", OR "PRINTER"

CONSOLE

ICKDSF - CMS/XA/ESA DEVICE SUPPORT FACILITIES 17.0

TIME:

14:09:51

05/14/08 PAGE 1

ENTER INPUT COMMAND:

CPVOL FMT MODE(ESA) UNIT(8228) VOLID(DK8228) NOVFY -

ENTER INPUT COMMAND:

RANGE(0,3338)

ICK00700I DEVICE INFORMATION FOR 8228 IS CURRENTLY AS FOLLOWS:

PHYSICAL DEVICE = 3390

STORAGE CONTROLLER = 3990

STORAGE CONTROL DESCRIPTOR = E9

DEVICE DESCRIPTOR = 0A

ADDITIONAL DEVICE INFORMATION = 4A001B35

TRKS/CYL = 15, # PRIMARY CYLS = 3339

ICK04000I DEVICE IS IN SIMPLEX STATE

ICK00091I 8228 NED=002105.000.IBM.13.000000022513

ICK091I 8228 NED=002105.000.IBM.13.000000022513

ICK03020I CPVOL WILL PROCESS 8228 FOR VM/ESA MODE

ICK03090I VOLUME SERIAL = DK8228

ICK03022I FORMATTING THE DEVICE WITHOUT FILLER RECORDS

ICK03011I CYLINDER RANGE TO BE FORMATTED IS 0 - 3338

ICK003D REPLY U TO ALTER VOLUME 8228 CONTENTS, ELSE T

U

ICK03000I CPVOL REPORT FOR 8228 FOLLOWS:

FORMATTING OF CYLINDER 0 STARTED AT: 14:09:51

FORMATTING OF CYLINDER 100 ENDED AT: 14:09:54

FORMATTING OF CYLINDER 200 ENDED AT: 14:09:56

....

FORMATTING OF CYLINDER 3100 ENDED AT: 14:12:07

FORMATTING OF CYLINDER 3200 ENDED AT: 14:12:10

FORMATTING OF CYLINDER 3300 ENDED AT: 14:12:13

FORMATTING OF CYLINDER 3338 ENDED AT: 14:12:14

VOLUME SERIAL NUMBER IS NOW = LX6PG2

CYLINDER ALLOCATION CURRENTLY IS AS FOLLOWS:

TYPE	START	END	TOTAL
----	-----	---	-----
PERM	0	3338	3339

ICK00001I FUNCTION COMPLETED, HIGHEST CONDITION CODE WAS 0  
14:12:14 05/14/08

ENTER INPUT COMMAND:  
END

ICK00002I ICKDSF PROCESSING COMPLETE. MAXIMUM CONDITION CODE WAS 0  
ENTER ALLOCATION DATA  
TYPE CYLINDERS

.....  
**page 1-end**  
**end**

HCPCCF6209I INVOKING ICKDSF.  
ICK030E DEFINE INPUT DEVICE: FN FT FM, "CONSOLE", OR "READER"  
CONSOLE  
ICK031E DEFINE OUTPUT DEVICE: FN FT FM, "CONSOLE", OR "PRINTER"  
CONSOLE

ICKDSF - CMS/XA/ESA DEVICE SUPPORT FACILITIES 17.0  
14:14:07

TIME:

05/14/08 PAGE 1

ENTER INPUT COMMAND:  
CPVOL ALLOC MODE(ESA) UNIT(8228) VFY(LX6PG2) -  
ENTER INPUT COMMAND:  
TYPE((PERM,0,3338))

ICK00700I DEVICE INFORMATION FOR 8228 IS CURRENTLY AS FOLLOWS:  
PHYSICAL DEVICE = 3390  
STORAGE CONTROLLER = 3990  
STORAGE CONTROL DESCRIPTOR = E9  
DEVICE DESCRIPTOR = 0A  
ADDITIONAL DEVICE INFORMATION = 4A001B35  
TRKS/CYL = 15, # PRIMARY CYLS = 3339

ICK04000I DEVICE IS IN SIMPLEX STATE  
ICK00091I 8228 NED=002105.000.IBM.13.000000022513  
ICK091I 8228 NED=002105.000.IBM.13.000000022513

ICK03020I CPVOL WILL PROCESS 8228 FOR VM/ESA MODE  
ICK03090I VOLUME SERIAL = LX6PG2  
ICK03024I DEVICE IS CURRENTLY FORMATTED WITHOUT FILLER RECORDS  
ICK003D REPLY U TO ALTER VOLUME 8228 CONTENTS, ELSE T

U  
ICK03000I CPVOL REPORT FOR 8228 FOLLOWS:

CYLINDER ALLOCATION CURRENTLY IS AS FOLLOWS:  
TYPE      START      END      TOTAL  
----      -      -      -  
PAGE      1      3338      3338

ICK00001I FUNCTION COMPLETED, HIGHEST CONDITION CODE WAS 0  
14:14:42      05/14/08

ENTER INPUT COMMAND:  
END

ICK00002I ICKDSF PROCESSING COMPLETE. MAXIMUM CONDITION CODE WAS 0  
Ready; T=0.06/0.15 14:14:42

---

### ***Registering the disks to the system***

After a DASD is formatted, make sure that the system recognizes them as available storage. This information is stored in the SYSTEM CONFIG file. Being recognized as available storage is analogous to (assuming the device is defined in the HCD IOCDS) issuing a VARY xxxx,ONLINE command and eventually putting that command in COMMNDxx or IEACMD00 of PARMLIB concatenation, if defined with OFFLINE attribute in z/OS (any mount usage attributes must also be considered). Linux systems do not have an equivalent step since disks are discovered in boot time by a hardware probing program and automatically appear as devices under /dev after the system finishes booting up.

Example 4-7 uses the same steps to access the MAINT CF1 disk read-write that you used earlier. It is good to remember the sequence of steps shown in Example 4-7.

#### *Example 4-7 Accessing the MAINT CF1 disk read-write*

---

```
==> q cpdisk
Label  Userid  Vdev Mode Stat Vol-ID Rdev Type  StartLoc  EndLoc
MNTCF1 MAINT  OCF1 A  R/O  530RES 0200 CKD      39        83
MNTCF2 MAINT  OCF2 B  R/O  530RES 0200 CKD      84       128
MNTCF3 MAINT  OCF3 C  R/O  530RES 0200 CKD     129       188
==> cprel a
CPRELEASE request for disk A scheduled.
HCPZAC6730I CPRELEASE request for disk A completed.
==> link * cf1 cf1 mr
==> acc cf1 f
```

---

To register the disks by updating the SYSTEM CONFIG file:

1. Edit the SYSTEM CONFIG file and specify each of the new page volumes (PAGE) by name as CP\_Owned. When your system IPLs, it will pick up these as paging volumes.

```
==> x system config f
...
/*****
/*                               CP_Owned Volume Statements                               */
*****/

CP_Owned Slot 1 LX6RES
CP_Owned Slot 2 LX6SPL
CP_Owned Slot 3 LX6PAG
CP_Owned Slot 4 LX6W01
CP_Owned Slot 5 LX6W02
CP_Owned Slot 6 LX6PG2
  CP_Owned Slot 7 RESERVED
  CP_Owned Slot 8 RESERVED
  CP_Owned Slot 9 RESERVED
  CP_Owned Slot 10 RESERVED
  CP_Owned Slot 11 RESERVED
  CP_Owned Slot 12 RESERVED
  CP_Owned Slot 13 RESERVED
...

```

2. Move down to the User\_Volume\_List section. User volumes (PERM) can be specified individually with the User\_Volume\_List statement, or with wild cards in the User\_Volume\_Include statement. Add the user volumes that to be used by the Linux guest:

```
*****/
/*                               User_Volume_List */
/*These statements are not active at the present time. They are */
/*examples, and can be activated by removing the comment delimiters */
*****/
USER_VOLUME_LIST <NW1A25>
USER_VOLUME_LIST <NW1A26>
USER_VOLUME_LIST <NW1A27>
USER_VOLUME_LIST <NW1A28>
USER_VOLUME_LIST <NW1A29>
/* User_Volume_List USRP01 */
/* User_Volume_List USRP02 */

```

3. Save your changes with the FILE subcommand.
4. Verify the integrity of the changes with the CPSYNTAX command, then put the MAINT CF1 disk back online.

The following example shows how you did this previously:

```
==> acc 193 g
==> cpsyntax system config f
CONFIGURATION FILE PROCESSING COMPLETE -- NO ERRORS ENCOUNTERED.
==> rel f (det
DASD OCF1 DETACHED
==> cpacc * cf1 a
CPACCESS request for mode A scheduled.
HCPZAC6732I CPACCESS request for MAINT's OCF1 in mode A completed.
==> q cpdisk
Label Userid Vdev Mode Stat Vol-ID Rdev Type StartLoc EndLoc
MNTCF1 MAINT OCF1 A R/O 520RES 0200 CKD 39 83
MNTCF2 MAINT OCF2 B R/O 520RES 0200 CKD 84 128
MNTCF3 MAINT OCF3 C R/O 520RES 0200 CKD 129 188
```

## Verifying the changes

Although the system sees the changes the next time you IPL it, you want the system to see the changes now. You can do that by dynamically adding the PAGE DASD to the CP-owned volumes:

```
define cpown slot 6 LX6PG2
Ready; T=0.01/0.01 13:58:38
```

Then, look at the page space, as shown in Example 4-8, by using the QUERY ALLOC PAGE command. This is analogous to the DISPLAY ASM command in z/OS, and the Linux `free` command.

*Example 4-8 Reviewing the newly created PAGE volume.*

---

```
q alloc page
      EXTENT  EXTENT  TOTAL  PAGES  HIGH  %
VOLID RDEV    START    END    PAGES  IN USE  PAGE USED
-----
LX6PAG 1A22      1      3338 600840      0      0  0%
LX6PG2 8228      1      3338 601020     13     51  0%
      -----
SUMMARY                1174K     13      1%
USABLE                  1174K     13      1%
Ready; T=0.01/0.01 14:40:42
```

---

To verify that the PERM volumes are now online, use the QUERY DASD command to query the DASDs that are seen by the system, as shown in Example 4-9 on page 183.

#### Example 4-9 Verifying the newly created PERM volumes

---

```
q dasd
DASD 1A20 CP OWNED LX6RES 78
DASD 1A21 CP OWNED LX6SPL 1
DASD 1A22 CP OWNED LX6PAG 0
DASD 1A23 CP OWNED LX6W01 113
DASD 1A24 CP OWNED LX6W02 4
DASD 1A25 CP SYSTEM NW1A25 0
DASD 1A26 CP SYSTEM NW1A26 0
DASD 1A27 CP SYSTEM NW1A27 0
DASD 1A28 CP SYSTEM NW1A28 0
DASD 1A29 CP SYSTEM NW1A29 0
DASD 8228 CP OWNED LX6PG2 0
Ready; T=0.01/0.01 14:48:20
```

---

### Creating the Linux MAINT user

Before bringing up Linux, create a user-to-host common files that will be used by every Linux guest system that you create. To bring up as many Linux guests as you want, create a boot-parameter file for each guest (instead of processing each manually every time). The benefit of creating a boot-parameter file is that the files necessary for booting Linux will not be duplicated in every guest system user space.

Log on as MAINT to continue configuring the z/VM system for installing Linux. As stated in “z/VM users and password planning” on page 140, the Linux administrator ID is LNXMAINT. Before making any changes to the USER DIRECT file to create its disks, make a copy of that file first:

```
==> copy user direct c = direorig = (oldd
```

### Setting up minidisk space for LNXMAINT

A small 20-cylinder minidisk is allocated at virtual address 191 and a larger 300 cylinder minidisk (approximately 225 MB), to be shared by many guests, is defined at virtual address 192. You can use one of your new DASDs designated as PERM space in your worksheet (Table B-1 on page 403), or you can use any available space on LX6W02 (which will most likely have some free space if you have been following this book’s installation steps) because you will use only 320 cylinders for the minidisks.

**Note:** Cylinder 0 must always be reserved for the label, therefore you should start minidisks at cylinder 1 if you choose to use one of the new DASDs.

To set up minidisk space for LNXMAINT:

1. Edit the USER DIRECT file and add the following user ID definition to the bottom of the file:

```
==> x user direct c
```

```
====> bottom
```

```
====> a 6
```

```
...
```

```
USER LNXMAINT LNXMAINT 64M 128M BEG
```

```
INCLUDE IBMDFLT
```

```
LINK TCPMAINT 592 592 RR
```

```
MDISK 0191 3390 <2050> 0020 <LX6W02> MR READ WRITE MULTIPLE
```

```
MDISK 0192 3390 <2070> 0300 <LX6W02> MR ALL WRITE MULTIPLE
```

```
*
```

```
...
```

```
====> file
```

Note the following points for the numbers in black:

- 1** User ID LNXMAINT has the same password; default size of storage (main memory) designated to this user is 64 MB plus 128 MB of extended storage, with class B, E, and G privileges.
  - 2** Include the profile named IBMDFLT (which is defined earlier in the USER DIRECT file).
  - 3** Link to the TCPMAINT 592 disk is read-only for access to FTP and other TCP/IP commands.
  - 4** Define a 191 minidisk of size 20 cylinders from volume LX6W02.
  - 5** Define 192 minidisk of size 300 cylinders (approximately 225MB) from volume LX6W02 with the special read password of ALL, which allows read-access from any user ID without a disk password.
  - 6** An empty comment line is for better readability.
2. When an MDISK statement is added or modified in the USER DIRECT file, always check for overlapping cylinders and gaps (although gaps only leave empty disk space, z/VM allows you to define multiple minidisks over the same disk space, which is not necessarily beneficial). To check, use the DISKMAP command, as previously stated in “Creating a disk” on page 134:

```
==> diskmap user
```

The minidisks with the END option specified in this directory will not be included in the following DISKMAP file.

File USER DISKMAP A has been created.

1  
2  
3  
4  
5  
6



The file created, USER DISKMAP A, contains a mapping of all minidisk volumes defined in the USER DIRECT file. It lists any overlaps or gaps found on the volumes.

3. Edit the file and turn off the prefix area with the XEDIT PREFIX OFF subcommand to view 80 columns:

```
==> x user diskmap
====> prefix off
```

4. Search for the text overlap by using the / (slash) subcommand:

```
====> /overlap
```

The following message appears, which means that no minidisks are overlapping each other:

```
DMSXDC546E Target not found.
```

Look at the rest of the file. Your LNXMAINT's minidisks definitions should be similar to ours, as shown in Figure 4-17. Notice that they are defined on the LX6W02 disk, unless you are using one of your new DASDs.

00236	-----						
00237							
00238	VOLUME	USERID	CUU	DEVTYPE	START	END	SIZE
00239	<b>LX6W02</b>	\$ALLOC\$	A03	3390	00000	00000	00001
00240		40SASF40	2D2	3390	00001	00150	00150
00241		OSADMIN2	191	3390	00151	00160	00010
	<...snip...>						
00331		CERON	191	3390	02040	02049	00010
<b>00332</b>		<b>LNXMAINT</b>	<b>191</b>	<b>3390</b>	<b>02050</b>	<b>02069</b>	<b>00020</b>
<b>00333</b>		<b>LNXMAINT</b>	<b>192</b>	<b>3390</b>	<b>02070</b>	<b>02369</b>	<b>00300</b>

Figure 4-17 USER DISKMAP file after the creation of LNXMAINT.

5. Quit the file USER DISKMAP with the QUIT command or by pressing F3.
6. If you have used one of your new DASDs, edit the USER DIRECT file again and add a new minidisk definition for that one very first cylinder you left out from it<sup>8</sup>. This prevents the system from reporting it as a gap.

The following example is the USER DIRECT file:

```
==> x user direct
====> /user $alloc
USER $ALLOC$ NOLOG
MDISK A01 3390 000 001 LX6RES R
```

<sup>8</sup> If you did not leave it out, than you probably didn't read through the NOTE in the beginning of "Setting up minidisk space for LNXMAINT" on page 183.

```
MDISK A02 3390 000 001 LX6W01 R
MDISK A03 3390 000 001 LX6W02 R
MDISK A04 3390 000 001 <NW1A25> R
```

7. When you are sure the minidisk layout is correct, the changes to the USER DIRECT file can be brought online with the DIRECTXA command:

```
==> directxa user
z/VM USER DIRECTORY CREATION PROGRAM - VERSION 5 RELEASE 3.0
EOJ DIRECTORY UPDATED AND ON LINE
HCPDIR494I User directory occupies 39 disk pages
```

8. If the DIRECTXA command fails, you must correct the problem before proceeding.

You have now defined your first z/VM user ID named LNXMAINT.

There is no equivalent process to this step in Linux because a user is not an entire virtual machine by itself, as it is in z/VM. When a Linux user is created, the information about it (user ID, password) is stored in a system file and a home folder is created for it in the /home directory.

## Getting in and customizing the new user ID

Now you should be able to logon to the new user ID and format its two minidisks:

1. Log off of MAINT and log on to LNXMAINT:

```
LOGON LNXMAINT
z/VM Version 5 Release 3.0, Service Level 0701 (64-bit),
built on IBM Virtualization Technology
There is no logmsg data
FILES: 0003 RDR, NO PRT, NO PUN
LOGON AT 05:41:34 EST THURSDAY 01/04/07
z/VM V5.3.0 2007-11-10 10:07
```

DMSACP112S A(191) **device error**

An error message ending in device error appears. When CMS is started, it tries to access the user's 191 minidisk as file mode A. The 191 minidisk has been defined to this user ID, however, it has never been formatted for a CMS file system<sup>9</sup>.

**Note:** DASDs used solely for holding minidisks do not have to be formatted as PERM space because each minidisk on it will be formatted later. In that case, formatting a cylinder and putting a label on it is adequate.

<sup>9</sup> Formatting a DASD as PERM storage is different from formatting a user minidisk for a CMS file system.

2. To format this disk for CMS use the **FORMAT** command. It requires a parameter specifying the file mode to access the disk as mode A in the following example:

```
==> format 191 a
DMSFOR603R FORMAT will erase all files on disk A(191). Do you wish
to continue?
Enter 1 (YES) or 0 (NO).
1
DMSFOR605R Enter disk label:
1xm191
DMSFOR733I Formatting disk A
DMSFOR732I 20 cylinders formatted on A(191)
```

3. Format the larger 192 disk as the D minidisk, which takes several minutes:

```
==> format 192 d
DMSFOR603R FORMAT will erase all files on disk D(192). Do you wish
to continue?
Enter 1 (YES) or 0 (NO).
1
DMSFOR605R Enter disk label:
1xm192
DMSFOR733I Formatting disk D
DMSFOR732I 300 cylinders formatted on D(192)
```

You have now formatted the two minidisks and accessed them as file modes A and D.

### ***Copying a PROFILE XEDIT***

Copy the PROFILE XEDIT from the MAINT 191 disk so that XEDIT sessions have a common interface among user IDs.

1. Use the **VMLINK** command to both link to the disk read-only and to access it as the highest available file mode. The default read password is read:

```
==> vmlink maint 191
ENTER READ PASSWORD:
==> read
DMSVML2060I MAINT 191 linked as 0120 file mode Z
```

2. Copy the PROFILE XEDIT to your A disk:

```
==> copy profile xedit z = a
```

## Creating a PROFILE EXEC

To create a simple PROFILE EXEC that is run each time this user ID is logged on:

1. Create the new file and add the following lines. REXX EXECs must always begin with a C language-style comment.

```
==> x profile exec a
====> a 5
/* PROFILE EXEC */
'acc 592 e'
'cp set run on'
'cp set pf11 retrieve forward'
'cp set pf12 retrieve'
====> file
```

This PROFILE EXEC accesses the TCPMAINT 592 disk as file mode E, sets CP run on (read section “Disconnecting” on page 60 for an explanation on the RUN parameter), and sets the retrieve keys per the convention.

You can add more configuration features to your profile. Although we do not mention them here because they do not relate to the installation steps themselves, you can see them in 5.2, “Running the system” on page 230.

2. You could test your changes by logging off and logging back on. However, typing the command PROFILE does the same. By default, CMS tries to access the 191 disk as A and the 192 disk as D. Also, you should have the TCPMAINT 592 disk accessed as E. To see your minidisks, use the QUERY DISK (q disk) command:

```
==> profile
DMSACP723I E (592) R/O
==> q disk
LABEL VDEV M STAT CYL TYPE BLKSZ FILES BLKS USED-(%) BLKS LEFT BLK TOTAL
LXM191 191 A R/W i20 i3390 4096 2 9-01 3591 3600
LXM192 192 D R/W 300 i3390 4096 0 11-00 53989 54000
TCM592 592 E R/O i67 i3390 4096 877 8167-68 3893 12060
MNT190 190 S R/O 100 i3390 4096 689 14325-80 3675 18000
MNT19E 19E Y/S R/O 250 3390 4096 1010 26665-59 18335 45000
MNT19I 120 Z R/O 175 i3390 4096 36 224-01 31276 31500
```

3. Verify that your F11 and F12 keys are set to the RETRIEVE command:

```
==> q pf11
PF11 RETRIEVE FORWARD
==> q pf12
PF12 RETRIEVE BACKWARD
```

## Getting the files required for Linux boot

In section “Setting up minidisk space for LNXMAINT” on page 183, you created two disks for the LNXMAINT user: the 191 and 192 disks. The 191 disk is to be

used as LNXMAINT's *home* disk, where its generic files will be. On the other hand, the 192 disk will be used to host all of the files necessary for a Linux virtual machine to boot. Later, in "Setting up common profiles for the Linux VMs" on page 193, you will set up a profile in the Linux guest that will link its 191 disk to LNXMAINT's 192 disk in read-only mode. By doing so, the guest's *home* disk can load the necessary Linux files by reading them from this linked LNXMAINT disk.

**Note:** To proceed with this section, make sure you have set up an FTP server in your z/VM, as mentioned in "Setting up an FTP server" on page 163. Again, sending the files through FTP is required to ensure that the transfer keeps the 80-character record length of the kernel and ramdisk files.

You have to send three files to your LNXMAINT 192 disk:

- ▶ Linux kernel
  - In SLES10, this is the `/boot/s390x/vmrdr.ikr` file of its first DVD or CD
  - In RHEL5, this is the `/images/kernel.img` file of its first DVD or CD
- ▶ Linux ramdisk
  - In SLES10, this is the `/boot/s390x/initrd` file of its first DVD or CD
  - In RHEL5, this is the `/images/initrd.img` file of its first DVD or CD
- ▶ SWAPGEN file found in the compressed file located in:  
<ftp://www.redbooks.ibm.com/redbooks/SG246695/>

**Note:** If your kernel and ramdisk are not in their 80-character record length, the kernel will not load.

The authors were given the access information for a SLES10SP2 and a RHEL5 U1 repositories. Because we had to pick up one on which to base our examples here, we decided to use SLES. However, comments for a RHEL system are highlighted when a different step or configuration is needed.

Put the three files in the same directory on your desktop (the machine you are using to connect to the mainframe) and use an FTP client to connect to the server, as shown in Example 4-10. Make sure you are logged off LNXMAINT at this time or your FTP client cannot access the disks in read-write mode.

*Example 4-10 Send the files to LNXMAINT's 192 disk via FTP*

```
# ftp <9.12.4.89> 1  
Connected to 9.12.4.89.
```

```
220-FTPSERVE IBM VM Level 530 at VMLINUX6.ITS0.IBM.COM, 16:33:09 EDT
THURSDAY 2008-05-15
220 Connection will close if idle for more than 5 minutes.
Name (9.12.4.89:root): lnxmaint 2a
331 Send password please.
Password:lnxmaint 2b
230 LNXMAINT logged in; working directory = LNXMAINT 191
Remote system type is z/VM.
ftp> cd lnxmaint.192 3
250 Working directory is LNXMAINT 192
ftp> put swapgen.exec 4
local: swapgen.exec remote: swapgen.exec
500 Unknown command, 'EPSV'
227 Data transfer will passively listen to 9,12,4,89,4,7
125 Storing file 'swapgen.exec'
100% |*****| 16750      14.60 MB/s
--- ETA
250 Transfer completed successfully.
16750 bytes sent in 00:00 (1.74 MB/s)
ftp> bin 5
200 Representation type is IMAGE.
ftp> site fix 80 6
200 Site command was accepted.
ftp> put vmrdr.ikr sles10s2.ikr 7
local: vmrdr.ikr remote: sles10s2.ikr
227 Data transfer will passively listen to 9,12,4,89,4,8
125 Storing file 'sles10s2.ikr'
100% |*****| 5904 KB    4.48 MB/s
00:00 ETA
250 Transfer completed successfully.
6046280 bytes sent in 00:01 (4.39 MB/s)
ftp> put initrd sles10s2.initrd 8
local: initrd remote: sles10s2.initrd
227 Data transfer will passively listen to 9,12,4,89,4,9
125 Storing file 'sles10s2.initrd'
100% |*****| 8067 KB    3.32 MB/s
00:00 ETA
250 Transfer completed successfully.
8261468 bytes sent in 00:02 (3.28 MB/s)
ftp> quit 9
221 Quit command received. Goodbye.
```

---

Note the following remarks to understand what you just did for each of the highlighted steps:

- 1** FTP to the z/VM server.
- 2a** Log in as LNXMAINT.
- 2b** Type in LNXMAINT's password.
- 3** Change the working *directory* on the server to LNXMAINT's 192 disk.
- 4** Send the swapgen.exec file as a text file.
- 5** Change ftp mode to binary.
- 6** Set the record format to fixed 80-byte records.
- 7** Send the kernel image and rename it to sles10s2.ikr on the server.
- 8** Send the ramdisk image and rename it to sles10s2.initrd on the server.
- 9** Quit.

Check that your files have been correctly uploaded. Log in as LNXMAINT and list your *D* file mode. The listing will be similar to the one in Figure 4-18. Make sure that your SLES10S2 IKR and SLES10S2 INITRD files have a record length of 80 bytes.

```
LNXMAINT FILELIST A0 V 169 Trunc=169 Size=13 Line=1 Col=1 Alt=0
Cmd  Filename Filetype Fm Format Lrecl Records  Blocks  Date Time
      SLES10S2 INITRD  D1 F      80 103269    2017  5/15/08 16:34:07
      SLES10S2 IKR    D1 F      80 75579     1122  5/15/08 16:33:59
      SWAPGEN  EXEC    D1 V      72 358       5    5/15/08 16:33:21

1= Help      2= Refresh  3= Quit    4= Sort(type) 5= Sort(date) 6=
Sort(size)
7= Backward 8= Forward  9= FL /n 10=
11= XEDIT/LIST 12= Cursor

====>

X E D I T 1 File
```

Figure 4-18 Checking the uploaded kernel, ramdisk and swapgen files.

## The Linux kernel loader script and boot parameters file

To have your Linux guest machines load the Linux kernel you just uploaded to LNXMAINT, create a script to automate the process. Also, it will be available to every Linux guest you create because you will place it on LNXMAINT's *D* file mode. Do this by issuing the following command and pasting the contents of Example 4-11 on page 192 into the script:

```
XEDIT SLES10S2 EXEC D
```

**Note:** REXX executables *must* begin with a C-like comment, `/* */` as shown in the example.

*Example 4-11 Script to load the Linux kernel*

---

```
/* EXEC punches sles10 sp2 kernel/ramdisk to reader and ipls it */

'cp spool pun *'
'cp close rdr'
'pur rdr all'
'pun sles10s2 ikr * (NOH'
'pun' userid() 'parmfile * (NOH' ❶
'pun sles10s2 initrd * (NOH'
'ch rdr all keep'
'ipl 00c clear'
```

---

You are only one step away from having all of the necessary files ready for a Linux boot. In fact, you are missing the file denoted number ❶ that is used by the loader script of Example 4-11.

To save time and typing, create a file containing all of the boot parameters you will need to perform a network-based installation of SLES10. Parameters such as the IP address to be used by the Linux guest, the netmask, the server repository URL, and so on can be placed into a single file and read by YaST<sup>10</sup> at boot time. Because this information is particular to each Linux guest that you create, you should name this file:

```
<LINUX_GUEST> PARMFILE D
```

The string `<LINUX_GUEST>` is the name of your z/VM user that will host the Linux system.

Notice that the instruction marked with ❶ in Example 4-11 makes use of the `userid()` REXX command to derive the complete file name. This means that each user loads a different parameters file when they run this script from within their Linux guest environments.

For now, you do not have a user for the Linux guest because you will create one in section “Create the first Linux VM” on page 195. For now, all you should do is name this parameter file the name you intend to give to your Linux guest user. In our examples, we use LNXCER for the Linux guest. See Example 4-12 on page 193.

---

<sup>10</sup> YaST stands for *Yet another Setup Tool*, and is the installer for SLES.



#### Example 4-12 Boot parameter file for Linux guest LNXCER

```
ramdisk_size=65536 root=/dev/ram1 ro init=/linuxrc TERM=dumb
hostip=<9.12.5.65> hostname=<ceron>
gateway=<9.12.4.1> netmask=<255.255.254.0>
broadcast=<9.12.7.255> layer2=0
readchannel=0.0.0600 writechannel=0.0.0601 datachannel=0.0.0602
nameserver=<9.12.6.7> portname=dontcare
install=<ftp://totibm:itso@9.12.4.69/code/sles10x>
instnetdev=osa osainterface=qdio osamedium=eth Manual=0
useshh=1 sshpassword=letmein
```

Make sure that you replace the <value> entries with the values that correspond to your resources according to your planning worksheet at Appendix B, “Planning worksheet” on page 403. Also, do not forget the last line highlighted in bold because in this book we instruct you to perform an SSH installation of SLES10.

### Setting up common profiles for the Linux VMs

To enable all Linux guests to see the 192 disk you created for LNXMAINT with all of the common files for boot, you have two options:

- ▶ The labor-intensive method is to put a LINK statement for every user description in MAINT’s USER DIRECT file.
- ▶ The easier method is to create a profile based on the default profile and add the proper lines for the link statements. Then, to make use of them, all you have to do when creating a Linux guest user is to import this new profile.

Our examples are based on the second approach, of course.

To enable all Linux guests by using the easier method:

1. Logon to MAINT and edit the USER DIRECT file:

```
==> x user direct c
```

In the USER DIRECT file, you can group statements that will be common to many user definitions in a construct called a *profile*. This profile can then become part of user definitions by using the INCLUDE statement. You used the existing profile TCPCMSU when you defined the LNXMAINT user.

2. Create a new profile named LNXDFLT. This will contain the user directory statements that common to all Linux user IDs. To save typing, use the "" prefix commands to duplicate the IBMDFLT profile that should be on lines 37-50:

```
""037 *****
00038 *
00039 PROFILE IBMDFLT
```

```

00040  SPOOL 000C 2540 READER *
00041  SPOOL 000D 2540 PUNCH A
00042  SPOOL 000E 1403 A
00043  CONSOLE 009 3215 T
00044  LINK MAINT 0190 0190 RR
00045  LINK MAINT 019D 019D RR
00046  LINK MAINT 019E 019E RR
00047  LINK MAINT 0402 0402 RR
00048  LINK MAINT 0401 0401 RR
00049  LINK MAINT 0405 0405 RR
""050 *****

```

3. Edit the duplicated profile by deleting the three LINK MAINT 040x lines, and inserting the lines that are in bold text from Example 4-13. See the notes following example.

*Example 4-13 Profile LNXDFLT*

---

```

PROFILE LNXDFLT
  IPL CMS
  MACHINE ESA 4
  CPU 00 BASE
  CPU 01
  NICDEF 600 TYPE QDIO LAN SYSTEM VSW1
  SPOOL 000C 2540 READER *
  SPOOL 000D 2540 PUNCH A
  SPOOL 000E 1403 A
  CONSOLE 009 3215 T
  LINK MAINT 0190 0190 RR
  LINK MAINT 019D 019D RR
  LINK MAINT 019E 019E RR
  LINK LNXMAINT 192 191 RR
  LINK TCPMAINT 592 592 RR

```

---

Notes about the example:

- 1** IPLs CMS when the user ID logs on.
- 2** Identifies machine as type ESA with a maximum of 4 CPUs that can be defined.
- 3** Defines the base CPU.
- 4** Defines a second CPU; *do not include* this if your LPAR has only a single Real IFL/CP.
- 5** Defines a virtual NIC connected to the VSWITCH starting at virtual address 600.
- 6** Provides read access to the LNXMAINT 192 disk as the user's 191 disk.
- 7** Provides read access to the TCPMAINT 592 disk, so that the user has access to TCPIP services such as an FTP client.

4. Save the file:

```
====> file
```

## Create the first Linux VM

In the virtualization discussion in section 2.2.1, “History of z/VM” on page 14, all you have to do to create a virtual machine in which Linux can run is to create a z/VM user. The first thing to do is to set up the user minidisks.

## Setting up minidisks

Create a new user for your Linux guest and set up its minidisks exactly the same way you did for the LNXMAINT user in “Setting up minidisk space for LNXMAINT” on page 183. Log on as MAINT and add a new user definition into the USER DIRECT C file. This is your first user to include the lnxdfit profile you created in “Setting up common profiles for the Linux VMs” on page 193. Example 4-14 shows a template you can use.

*Example 4-14 Create the Linux guest user.*

---

```
user <lnxcer> <lnxcer> 512M 2G BDEG
include lnxdfit
option lnknopas applmon
mdisk 100 3390 0001 3338 <nw1a25> mr lnx4vm lnx4vm lnx4vm
mdisk 103 3390 0001 3338 <nw1a26> mr lnx4vm lnx4vm lnx4vm
mdisk 104 3390 0001 3338 <nw1a27> mr lnx4vm lnx4vm lnx4vm
mdisk 105 3390 0001 3338 <nw1a28> mr lnx4vm lnx4vm lnx4vm
mdisk 106 3390 0001 3338 <nw1a29> mr lnx4vm lnx4vm lnx4vm
```

---

The example defines this Linux user ID as having the following minidisks and virtual disks:

- 100           A minidisk to hold the /boot partition; the remaining space is given to the system LVM, where all other partitions will be located. More about Linux LVM is described in “Linux Logical Volume Manager” on page 307.
- 101-102       These are virtual disk (VDISK) swap spaces created by SWAPGEN EXEC upon logging on. They are *not* defined in USER DIRECT, but dynamically in the user’s PROFILE EXEC when the user ID logs on.
- 103-106       These minidisks are to be managed by the Linux system LVM.

**Important:** A minimal Linux guest system fits onto a single 3390-3 DASD, and this is the recommended practice in the field. This practice requires that you do not use GNOME or KDE window managers in order to retain the small size of the installed system. Our example does not do this because we want to show the use of LVM and KDE.

To avoid a one-cylinder gap being reported on each user volume, use the user ID \$ALLOC\$. This user is set to NOLOG which means it can never be logged onto. Thus, it is not a conventional user ID, rather it is a convenient place to put dummy minidisks definitions for cylinder 0 of all PERM volumes. The user ID \$ALLOC\$ is in the beginning of the USER DIRECT C, near line 100. Include a definition for each of your volumes, as shown in Example 4-15.

*Example 4-15* Avoiding a 1-cylinder gap being reported

---

```
00104 *
00105 USER $ALLOC$ NOLOG
00106 MDISK A01 3390 000 001 LX6RES R
00107 MDISK A02 3390 000 001 LX6W01 R
00108 MDISK A03 3390 000 001 LX6W02 R
00109 MDISK A04 3390 000 001 <NW1A25> R
00110 MDISK A05 3390 000 001 <NW1A26> R
00111 MDISK A06 3390 000 001 <NW1A27> R
00112 MDISK A07 3390 000 001 <NW1A28> R
00113 MDISK A08 3390 000 001 <NW1A29> R
00114 *
```

---

## Updating the autolog profile

The new Linux ID you defined must have access to the VSWITCH. To do this automatically when the system IPLs, add the SET VSWITCH command with the GRANT parameter to AUTOLOG1's PROFILE EXEC. Also, an XAUTOLOG statement can be added for your Linux user ID to be automatically logged on at z/VM IPL time.

To accomplish those, log in as MAINT and make sure your AUTOLOG1's profile looks like the one shown in Example 4-16.

*Example 4-16* Granting users access to the virtual switches

---

```
==> link autolog1 191 1191 mr
==> acc 1191 f
==> x profile exec f // add two lines
/*****/
/* Autolog1 Profile Exec */
/*****/
```

```

'cp xautolog tcpip'          /* start up TCPIP */
'CP XAUTOLOG DTCVSW1'      /* start VSWITCH controller 1 */
'CP XAUTOLOG DTCVSW2'      /* start VSWITCH controller 2 */
'cp set pf12 ret'          /* set the retrieve key */
'cp set mdc stor 0m 128m'   /* Limit minidisk cache in CSTOR */
'cp set mdc xstore 0m 0m'   /* Disable minidisk cache in XSTOR */
'cp set srm storbuf 300% 250% 200%' /* Overcommit memory */
'cp set signal shutdown 180' /* Allow guests 3 min to shut down */

/* Grant access to VSWITCH for each Linux user */
'cp set vswitch vsw1 grant <lnxcer>'

/* XAUTOLOG each Linux user that should be started */
'cp xautolog <lnxcer>'

'cp logoff'                  /* logoff when done */
====> file

```

---

These changes do not take effect until the next IPL, so you must grant this user ID access to the VSWITCH for this z/VM session. This is done by running the following command, as the MAINT user:

```

==> set vswitch vsw1 grant <lnxcer>
Command complete

```

## Setting up the Linux guest profile

This is the last step before you run Linux in your guest system the first time. The guest profile should be common among the guests you create, so the best place to put it is into LNXMAINT's 192 disk, which is mapped as the A file mode of those guests by the lnxdfil profile that you created in "Setting up common profiles for the Linux VMs" on page 193.

Log in as LNXMAINT and modify the PROFILE EXEC D file to look like Example 4-17.

*Example 4-17 Linux guests profile*

```

/* PROFILE EXEC */
'CP SET RUN ON'
'CP SET PF11 RETRIEVE FORWARD'
'CP SET PF12 RETRIEVE'
'ACC 592 C'
'SWAPGEN 101 524288'
'SWAPGEN 102 1048576'
'PIPE CP QUERY' userid() '| var user'
parse value user with id . dsc .
ipldisk=100

```

1  
2

```

if (dsc = 'DSC') then
'CP IPL' ipldisk
else
do
say 'Want to ipl Linux from DASD' ipldisk'? y/n'
parse upper pull answer .
if (answer = 'Y') then
'CP IPL' ipldisk
end

```

---

Review the following aspects about the numbered statements in the example:

- 1,2** These lines create a swap space as disks *101* and *102* for Linux each time the virtual machine is started.

**Note:** Define the minimum amount of swap space as is possible, depending on your guest system's purposes. Doing so optimizes your z/VM system storage management. In our example, we used 512 MB and 1 GB because we were not worried about performance nor memory constraints.

- 3** This statement uses the parsed value stored in the *DSC* variable to check whether this user is being automatically logged in. If it is the case, then the script will IPL what is in disk *100*, which is where the Linux image should be after the installation.
- 4** In case the previous check concludes that the user actually performed an ordinary login, then the script asks if you want to IPL Linux on disk *100*.

We now install Linux onto our guest. Log in as your Linux guest user and press Enter to run the guest's profile. The output will be similar to the output in Figure 4-19 on page 199.

```
00: ipl cms
z/VM V5.3.0   2008-05-06 13:40

DMSACP723I A (191) R/O
DMSACP723I C (592) R/O
DIAG swap disk defined at virtual address 101 (64989 4K pages of
swap space)
DIAG swap disk defined at virtual address 102 (129981 4K pages of
swap space)
Want to ipl Linux from DASD 100? y/n
n
Ready; T=0.01/0.04 09:49:42
```

*Figure 4-19 Logging in as the Linux guest user*

Notice that the swap space is automatically generated, as we mentioned earlier. Also notice that, because this was not an auto login, the system prompts you whether to IPL disk 100. Answer no (n), because the Linux image is not yet installed onto disk 100.

#### 4.4.2 Booting the Linux kernel for installation

Because you invested your time in configuring a common Linux user ID (LNXMAINT) before, now all you have to do to start the Linux installation is to call the SLES10S2 EXEC script that you created in “The Linux kernel loader script and boot parameters file” on page 191. Figure 4-20 on page 200 shows how to call it and the resulting output until the Linux kernel starts running.

```

Ready; T=0.01/0.04 09:49:42
sles10s2
00: 0000003 FILES PURGED
00: RDR FILE 0043 SENT FROM LNXCER PUN WAS 0043 RECS 076K CPY 001 A NOHOLD
NOKEEP
00: RDR FILE 0044 SENT FROM LNXCER PUN WAS 0044 RECS 0009 CPY 001 A NOHOLD
NOKEEP
00: RDR FILE 0045 SENT FROM LNXCER PUN WAS 0045 RECS 103K CPY 001 A NOHOLD
NOKEEP
00: 0000003 FILES CHANGED
00: 0000003 FILES CHANGED
Linux version 2.6.16.21-0.8-default (geeko@buildhost) (gcc version 4.1.0
(SUSE L
inux)) #1 SMP Mon Jul 3 18:25:39 UTC 2006
We are running under VM (64 bit mode)
Detected 2 CPU's
Boot cpu address 0
Built 1 zonelists
Kernel command line: ramdisk_size=65536 root=/dev/ram1 ro init=/linuxrc
TERM=dumb hostip=9.12.5.65 hostname=ceron
gateway=9.12.4.1 netmask=255.255.254.0
broadcast=9.12.7.255 layer2=0
readchannel=0.0.0600 writechannel=0.0.0601 datachannel=0.0.0602
nameserver=9.12.6.7 portname=dontcare
install=ftp://totibm:itso@9.12.4.69/code/sles10x
instnetdev=osa osainterface=qdio osamedium=eth Manual=0
usessh=1 sshpassword=letmein
PID hash table entries: 4096 (order: 12, 131072 bytes)
Dentry cache hash table entries: 131072 (order: 8, 1048576 bytes)
Inode-cache hash table entries: 65536 (order: 7, 524288 bytes)
Memory: 496640k/524288k available (4298k kernel code, 0k reserved, 1401k
data, 1
96k init)
Security Framework v1.0.0 initialized
Mount-cache hash table entries: 256
checking if image is initramfs... it is
Freeing initrd memory: 8067k freed
cpu 0 phys_idx=0 vers=FF ident=04DE50 machine=2097 unused=8000
cpu 1 phys_idx=1 vers=FF ident=04DE50 machine=2097 unused=8000
Brought up 2 CPUs
migration_cost=1000
NET: Registered protocol family 16
debug: Initialization complete
TC classifier action (bugs to netdev@vger.kernel.org cc hadi@cyberus.ca)

```

Figure 4-20 Booting the Linux kernel for installation.



At this point, your Linux kernel is up and running and the ramdisk is taking care of downloading the installation *stage 2* file from your server repository. This stage 2 file is actually the one that contains the installer program itself, YaST in case of SLES10. Because we chose to install through SSH, the boot displays a message similar to Figure 4-21.

```
setting root pwd to 'letmein'
Starting SSH daemon ...

eth0: <BROADCAST,MULTICAST,UP> mtu 1492 qdisc pfifo_fast qlen 1000
      link/ether 02:00:01:00:00:02 brd ff:ff:ff:ff:ff:ff
      inet 9.12.5.65/23 brd 9.12.5.255 scope global eth0
      inet6 fe80::200:100:400:2/64 scope link
          valid_lft forever preferred_lft forever

      ***  sshd has been started  ***

      ***  login using 'ssh -X root@ceron'  ***
      ***  run 'yast' to start the installation  ***
```

Figure 4-21 YaST ready for an SSH installation

The reason we chose SSH instead of the IBM Connection terminal is because an SSH connection can refresh the windows during the installation wizard and its a colorful console.

**Note:** Read *z/VM and Linux on IBM System z: The Virtualization Cookbook for SLES9*, SG24-6695 for a graphical installation of SLES10 by using a VNC client.

To proceed with the installation, open an SSH connection to the Linux guest (you can do this with the Linux `ssh` command or use an SSH client, such as PuTTY, if you are in Windows. Login in as root and use the *letmein* password defined to protect the root user during the installation. After you are logged in, type `yast` to start the installation.

**Note:** You will be prompted to set the real root password of your system later during the installation. Do not be concerned about having a weak root password while installing the system.

## Beginning a YaST installation

When YaST comes online on your SSH connection, it guides you through an installation wizard. Perform the following steps:

**Hint:** The Tab key cycles you forward in the menu entries. The Escape+Tab combination cycles you backward in the menu entries. The Space bar toggles between a check box and the opening of a selection box.

The installation program that is running is **yast2**.

To begin a YaST installation:

1. Choose the language, **English**, (or your language) and click **Next**.
2. The SLES10 SP2 license agreement window opens. If you agree, select **Yes, I agree to the License Agreement** and Click **Next**.
3. The Disk Activation window opens. Select **Configure DASD Disks**.
4. The YaST2 DASD Disk Management window opens, displaying all the DASDs available to your Linux guest, including the z/VM disks that your guest user uses for itself but not for hosting Linux, such as its 191 disk.

Use only the 100-106 disks for your Linux installation because that is what you have set up for it. In the window:

- a. Highlight each disk and click **Select or Deselect** to select it; or simply press Enter while highlighting a given disk. The word Yes appears next to the disks you select.
- b. Activate the selected disks for the Linux you are about to install by selecting **Perform Action** → **Activate**, as shown in Figure 4-22 on page 203.

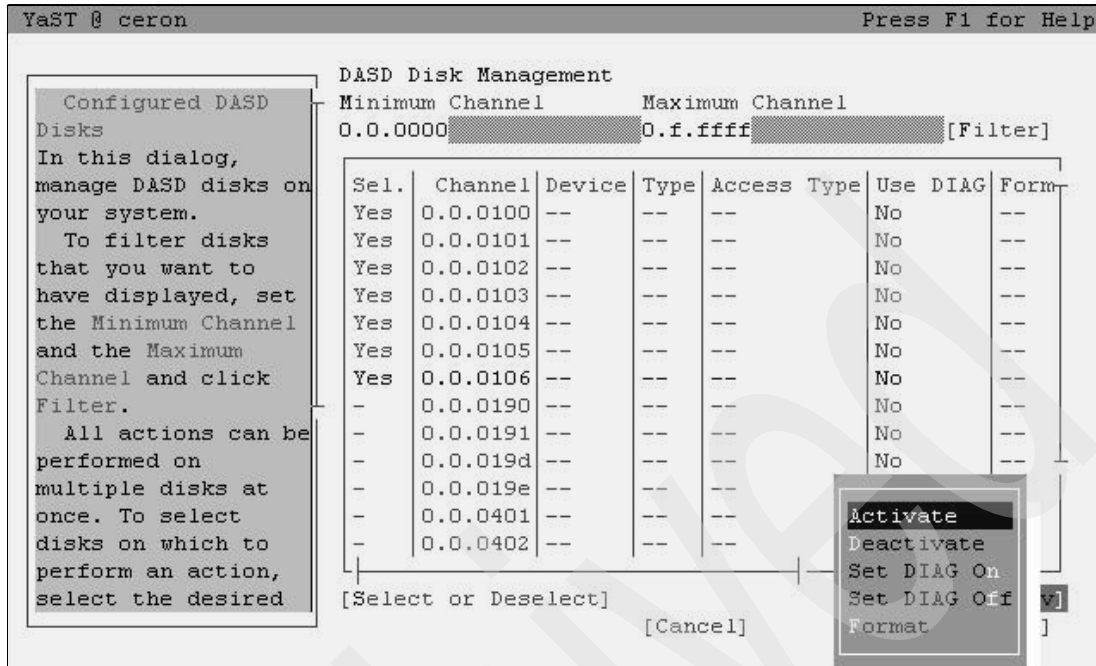

Figure 4-22 DSD available to the guest system

- c. The disks that are not meant for swapping must be formatted so that Linux can use them. Deselect disks 101 and 102, so that the other disks for the Linux image remain selected.

Select **Perform Action** → **Format** → **Activate**, as shown in Figure 4-23 on page 204.

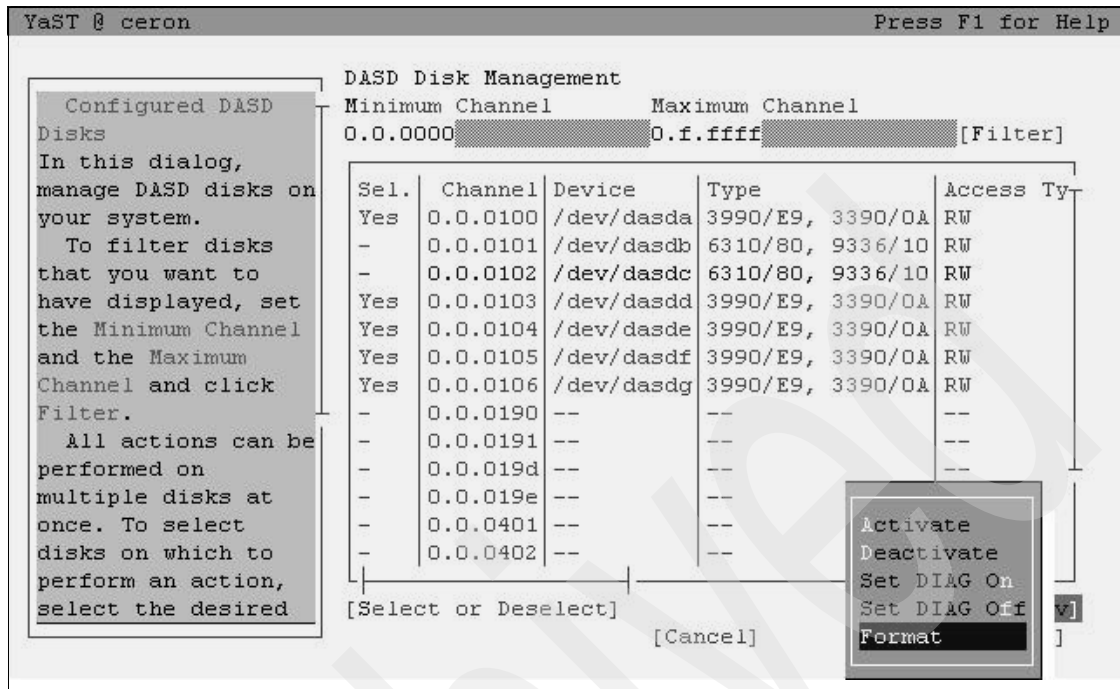

Figure 4-23 Selecting the PERM volumes for Linux formatting

5. In the window that prompts you for one Parallel Formatted Disks, click **OK**.
6. Click **Yes** to the question Really format the following?

A progress indicator window displays the progress (see Figure 4-24 on page 205). This step can take 5-15 minutes depending on the type of channel and the speed of the disks.

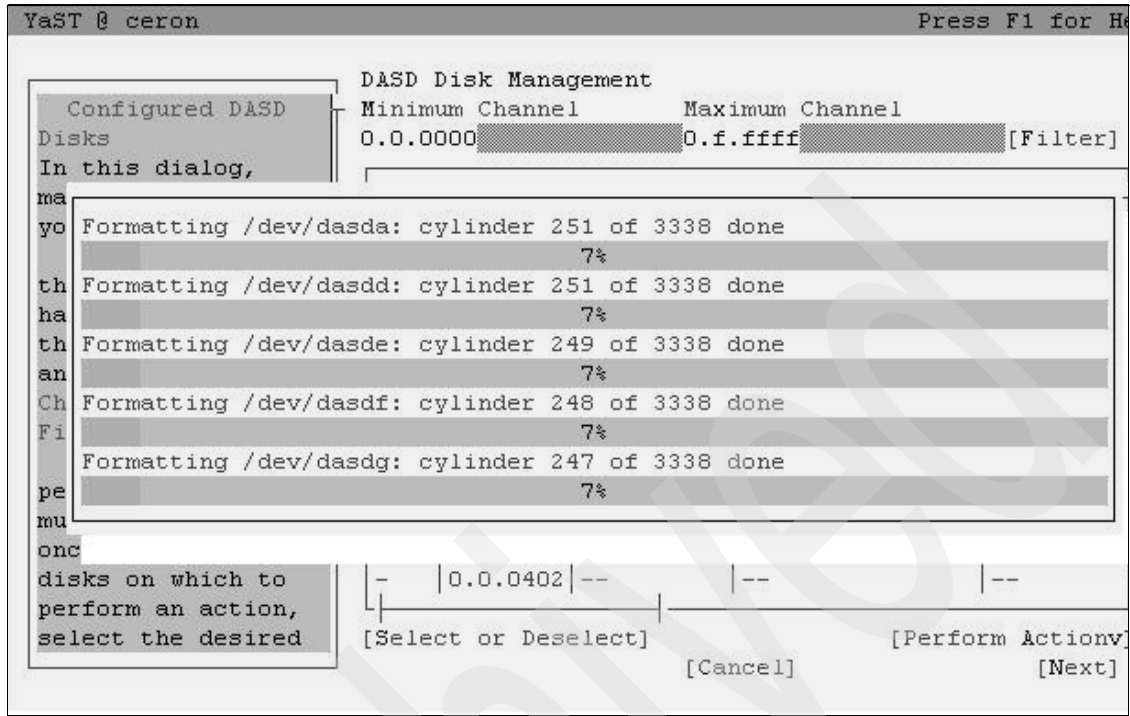

Figure 4-24 DSD formatting

7. When the formatting is complete, click **Next**, and in the Disk Activation window click **Next** again.  
A window prompts you for the installation mode.
8. Select **New installation** and Click **Next**.  
The Clock and Time Zone window opens.
9. Choose your time zone, set the clock, and click **Next**.  
The Installation Settings window opens.
10. Click **Partitioning**.  
The Expert Partitioner window opens, shown in Figure 4-25 on page 206.

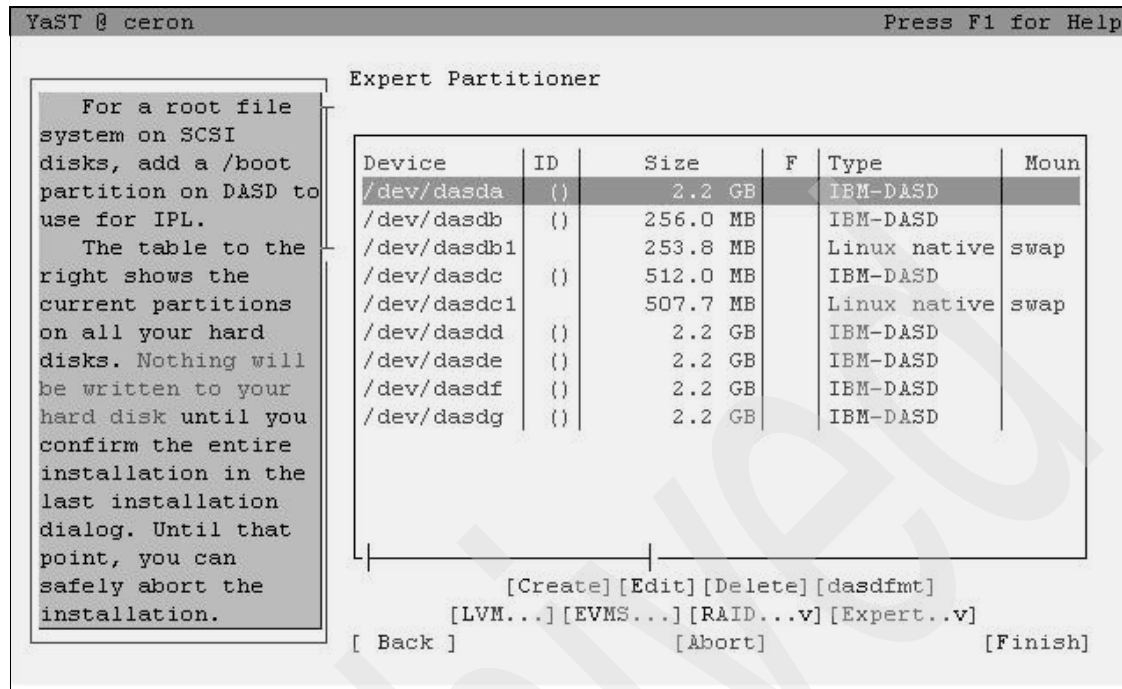

Figure 4-25 Creating Linux partitions

We use LVM to join our five DASDs together to make them appear to Linux as a single 10 GB disk. By doing this, we can create Linux partitions, such as /home, to spawn multiple disks and grow as large as we want. However, one of the partitions must be left out of the LVM so the system can boot: the /boot partition.

**Note:** We recommend you thoroughly read the following articles for a discussion about LVM, regarding disk performance optimization and volume management:

- ▶ [http://www.ibm.com/developerworks/linux/linux390/perf/tuning\\_rec\\_dasd\\_optimizedisk.html](http://www.ibm.com/developerworks/linux/linux390/perf/tuning_rec_dasd_optimizedisk.html)
- ▶ [http://www.ibm.com/developerworks/linux/linux390/perf/tuning\\_rec\\_dasd\\_volMan.html](http://www.ibm.com/developerworks/linux/linux390/perf/tuning_rec_dasd_volMan.html)

**Important:** A minimalistic Linux guest system fits onto a single 3390-3 DASD, and this is the recommended practice in the field. Such practice requires not using GNOME or KDE window managers to keep the installed system small. Our example does not do this because we want to show the use of LVM and KDE.

11. Click **Create**. Because /dev/dasda has no partitions, the “Create a Primary Partition on /dev/dasda” window opens, similar to Figure 4-26.

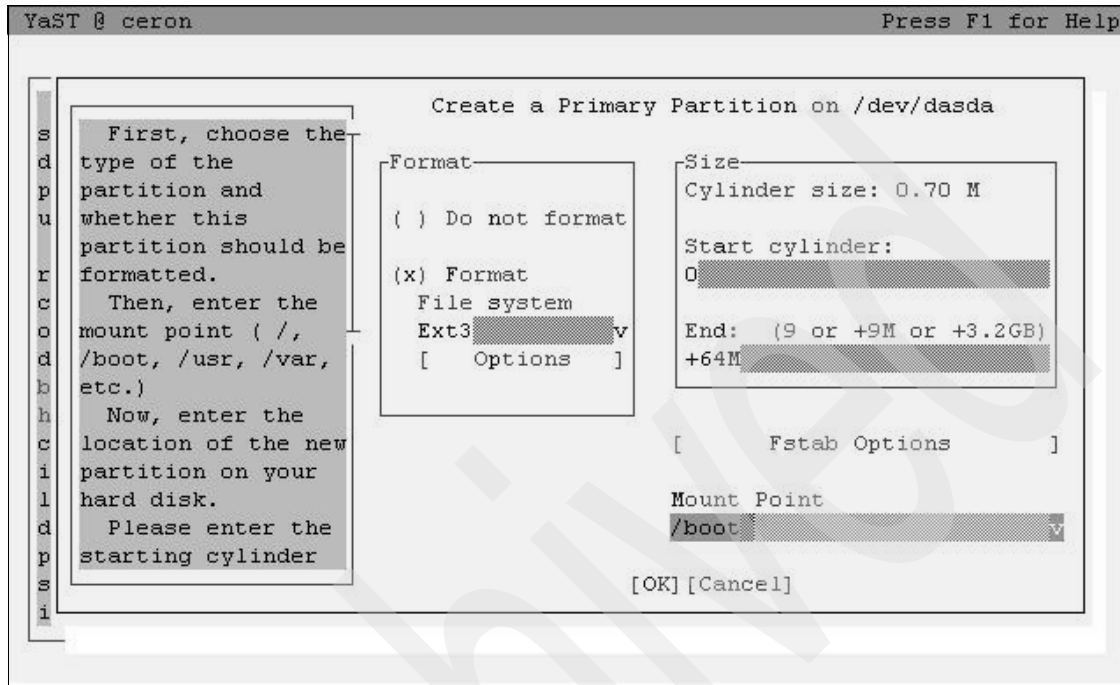

Figure 4-26 Creating the boot partition outside of LVM

In the window:

- Select **Format** (an x is inserted).
- Choose **Ext3** as the file system

**Important:** The authors recommend that you do not use ReiserFS (an alternative, advanced file system) because the file structure tree can become corrupted, which would force you to run an `fsck --rebuild-tree` command, a time consuming and dangerous task. For a discussion about file system types, refer to the journaling file systems discussion in:

[http://www.ibm.com/developerworks/linux/linux390/perf/tuning\\_res\\_journaling.html](http://www.ibm.com/developerworks/linux/linux390/perf/tuning_res_journaling.html)

- Set the first cylinder to 0 (zero). For the end cylinder, use +64M to denote that you want a partition that is 64 MB in size. Because the /boot can host only the kernel, ramdisk and bootloader files, this is more than enough

space for it. It is also enough space to host four to five different kernel and ramdisk images.

d. Select a mount point of /boot.

e. Click **OK**.

12. Create another partition on dasda repeating the same actions described in the previous step. The start cylinder is displayed as the next available cylinder. Make sure the ending cylinder is the last one available (3337 for a 3390-3 DASD) and choose the empty mount point for it (the last choice in the mount point selection box).

Repeat this step for each of the other disks, except dasdb and dasdc because they are swap space. Make sure the partition you create uses the space of all of those disks. You can safely ignore warnings that request you to create a root partition (/) for now. The goal of this step is only to make the system able to see a *Linux Native* partition on each of the other disks, otherwise LVM will fail to use them.

Upon completion of this step, the Expert Partitioner window looks similar to Figure 4-27.

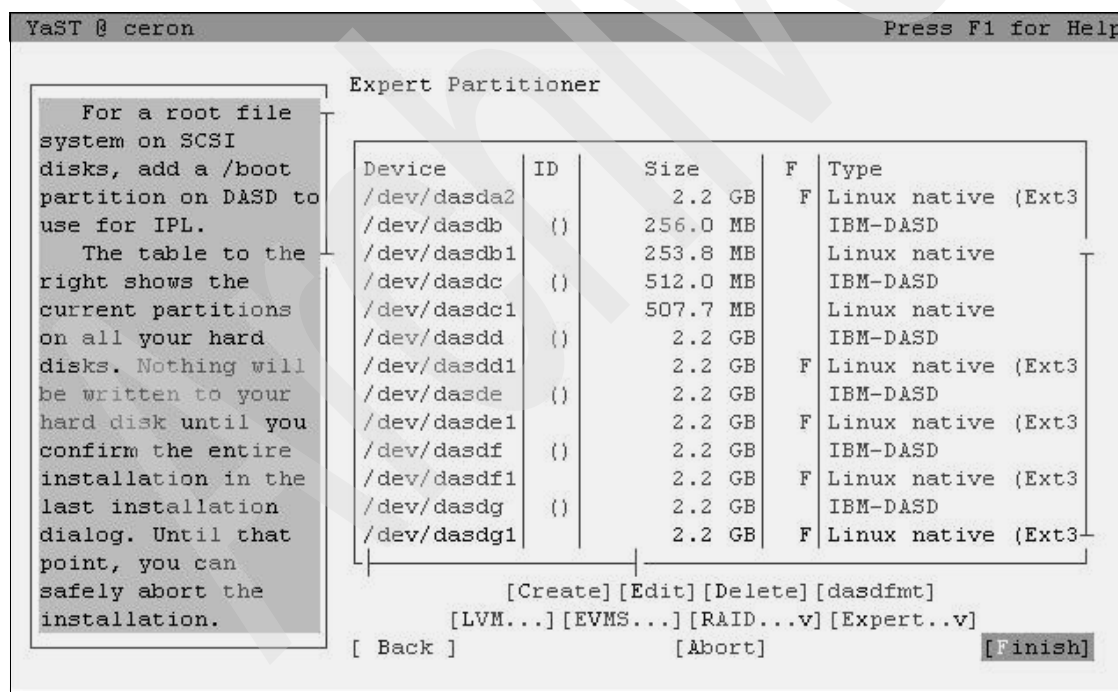

Figure 4-27 Partitions before applying LVM

13. Click **LVM** to proceed and create the LVM.



14. For the LVM, choose a volume group name and a physical extend size. We recommend you use the defaults that YaST presents you. Click **OK** to proceed.

All of your remaining partitions are shown in a list.

15. Add each remaining partition to the LVM by highlighting it and pressing Enter or by clicking **Add Volume**. Your window looks similar to the state shown in Figure 4-28.

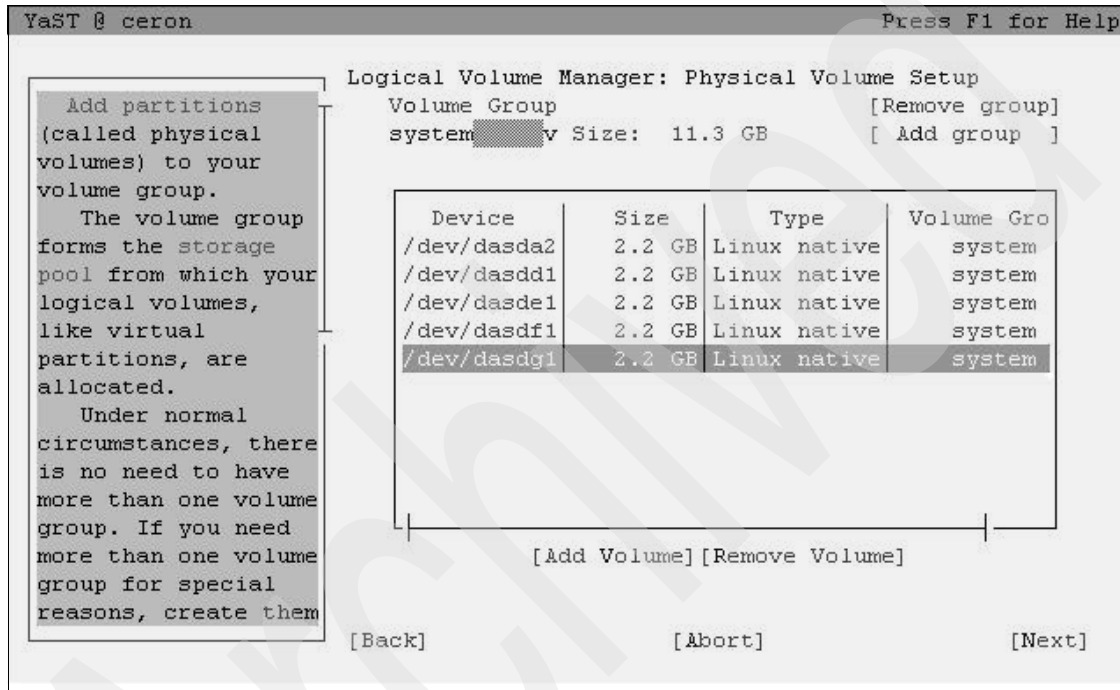

Figure 4-28 Creating an LVM

16. Click **Next** to proceed.

The LVM Logical Volumes management window displays the `/boot` partition you created and the two swap partitions. In the previous step you created a *logical group*, which can be understood as creating a logical disk, or DASD in a z/VM nomenclature.

You must now create the *logical volumes* inside the logical group. Logical volumes are nothing more than Linux partitions, such as `/`, `/home`, `/var` and so on. Think of logical volumes as z/VM minidisks.

17. Click **Add**. The Create Logical Volume window, similar to Figure 4-29 on page 210, is displayed.

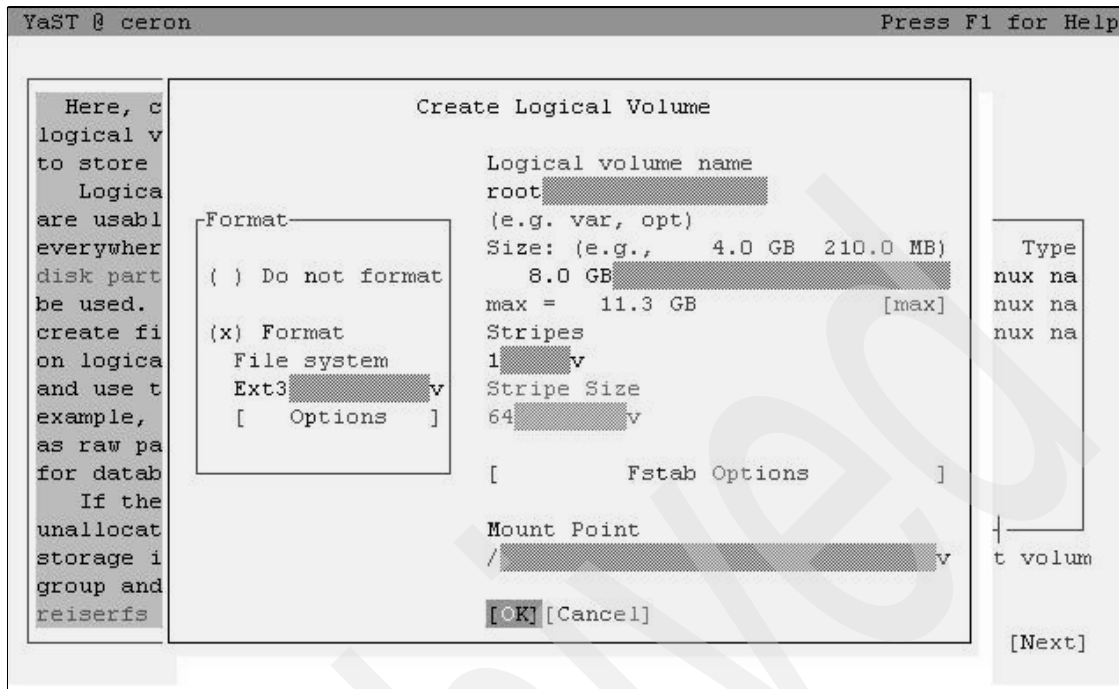

Figure 4-29 Creating the root partition

18. Perform the following steps:

- a. Format the volume as ext3.
- b. Give it a meaningful logical volume name. Since this will be our root partition, we named it as *root*.
- c. Set its size. We are using 8GB here because we intend to create a */home* partition around 3GB later.
- d. Use the default value for *stripes*, unless you want to optimize the system for performance, as stated earlier in the LVM reference we provided.
- e. Pick up */* as the mount point
- f. Click **OK**.

19. Repeat the previous step to create a */home* partition. Name its volume as *home*. When you set up the space for it, click the **[max]** button, to use all of the remaining space in the volume group.

Upon the completion of this step, the window is similar to the one in Figure 4-30 on page 211.

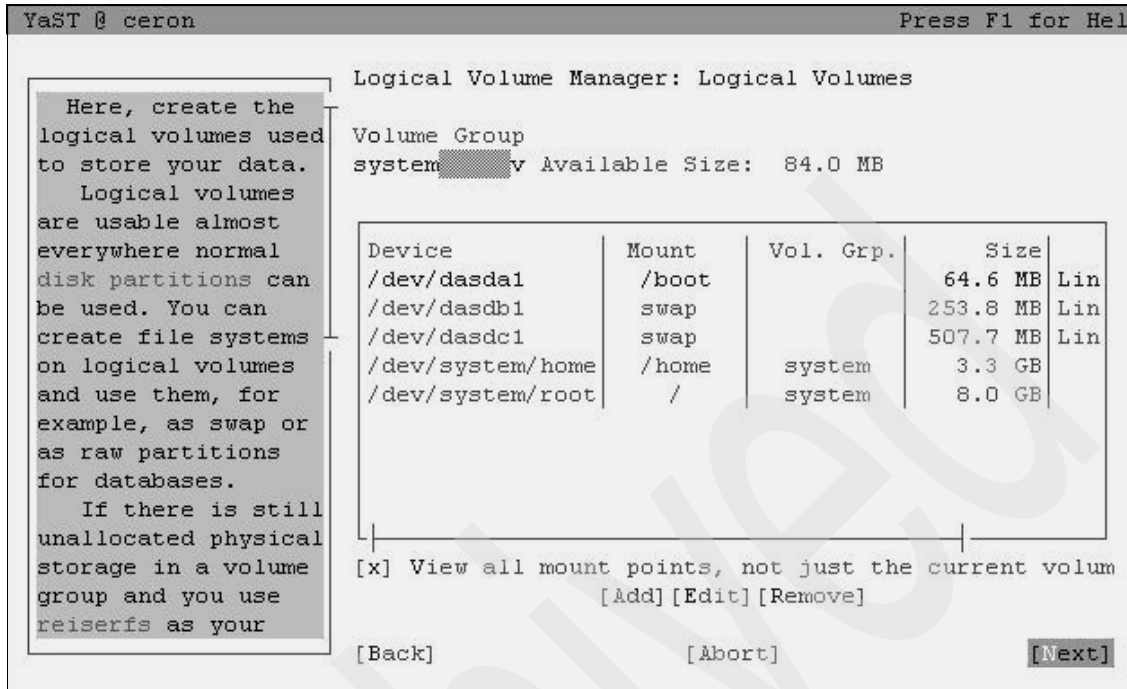

Figure 4-30 LVM layout

20. Click **Next** to proceed to the main partitioning menu.

21. Click **Finish** to exit the main partitioning menu.

You are now returned to the main wizard.

### Continuing the YaST installation

In the main wizard, select the packages to install:

1. Select **Change** → **Software**
2. Filter the packages by patterns by clicking the **Filter** selection box.
3. Select any patterns you want for installation. Because we provide examples for connecting to a KDE environment through a VNC connection, we deselect the GNOME Desktop environment and select the KDE one. Click **OK** when you are done.

The packages scheduled for installation are listed, based on the patterns you chose (by filtering) in the previous step.

4. Click **Accept** to return to the installation wizard.

Based on the patterns selected, you might have to accept certain dependencies. If that happens, click **OK** to return to the installation wizard.

5. Click **Accept** to start the installation. A confirmation window is displayed.
6. Click **Install**. Installation begins, which you can watch as it happens.

### Booting your new Linux system from disk

After the first part of installation completes, your Linux system shuts down. Return to your z/VM 3270 session. IPL the newly installed system from disk to continue the installation.

To boot your new Linux system from disk:

1. Observe the following messages as the system powers down:

Power down.

```
00: HCPGSP2629I The virtual machine is placed in CP mode due to a
SIGP stop from
CPU 01.
```

```
01: HCPGSP2630I The virtual machine is placed in CP mode due to a
SIGP stop and
store status from CPU 01.
```

2. Boot the new kernel: IPL the disk using the command **ipl 100** (where 100 is the disk address of the boot record):

```
==> ipl 100
```

```
00: zIPL v1.6.3 interactive boot menu
```

```
00:
```

```
00: 0. default (ipl)
```

```
00:
```

```
00: 1. ipl
```

```
00: 2. failsafe
```

```
00: 3. ipl
```

```
00: 4. failsafe
```

```
00:
```

```
00: Note: VM users please use '#cp vi vmsg <number>
<kernel-parameters>'
```

```
00:
```

```
00: Please choose (default will boot in 10 seconds):
```

3. At this prompt, either wait 10 seconds for the default IPL to proceed or try to type the following command, if you can type quickly enough:

```
#cp vi vmsg 0
```

The installation program brings up an SSH server again, as shown in Figure 4-31 on page 213, so you can begin completing the installation.

```
***  sshd has been started  ***

you can login now and proceed with the installation
run the command '/usr/lib/YaST2/startup/YaST2.ssh'

active interfaces:

eth0      Link encap:Ethernet  HWaddr 02:00:01:00:00:02
          inet addr:9.12.5.65  Bcast:9.12.5.255  Mask:255.255.254.0
--
lo        Link encap:Local Loopback
          inet addr:127.0.0.1  Mask:255.0.0.0
```

Figure 4-31 YaST messages in first boot.

## Completing YaST installation

Return to the same SSH client used for the first part of the installation, described in “Beginning a YaST installation” on page 202.

### To complete the installation:

1. Log in using the same SSH password (letmein in this example) as the one used to first bring up YaST.  
A window opens for setting the root password.
2. Enter your root password twice and click **Next**. *Do not forget* this password!  
The first window you see is probably similar to the one you saw last time: package installation. However, depending on your patterns selection, the window has probably completed and instead the “Hostname and Domain Name” window is displayed.
3. Enter the required values, in this example *ceron* is the host name and *itso.ibm.com* is the domain name. Unless of course you have one DHCP server in your environment, uncheck the **Change Hostname via DHCP** check box.
4. Click **Next**. The Network Configuration window is displayed.
5. In *Firewall is enabled*, click the word **enabled** to change it to **disabled**.
6. Enable the VNC remote administration by clicking **Change** → **VNC Remote Administration**. All other values should be correct, so click **Next**.

**Warning:** Disabling the firewall is not a good practice. We are doing it however, to simplify our examples. Later, you should activate the firewall and block the ports for services at which you do not want your system to serve incoming connections.

The Test Internet Connection window opens.

7. Select **No, skip this test** and click **Next**.
8. In the Installation Settings window, select **Skip configuration** and click **Next**.
9. In the User Authentication Method window, accept the default of **Local (/etc/passwd)** and click **Next**.
10. In the “Add a new local user” window, you may choose to add a local user if you do not want to use the system as `root` every time. When you are done, click **Next**.
11. In the “Writing the system configuration” window the **SUSEconfig** tool writes all your settings to disk.
12. In the Release Notes window, review the release notes, and click **Next**.
13. In the Hardware Configuration window select **Skip Configuration**, and click **Next**.
14. In the Installation Completed window, if you intend to clone the system, check the box **Clone This System for Autoyast**, and click **Finish**. If you do not intend to clone the system, you may leave the check box unselected.

Congratulations! You are done installing Linux!

### 4.4.3 Logging into the Linux system

To close the installation guide in a great style, nothing is better than logging into the system you have just installed in a nice and pleasant way: Virtual Network Computing (VNC). To do that, you must have a VNC client installed on your machine. You can use Linux’s `vncviewer` client or get one for Windows, such as RealVNC. In our examples we use RealVNC.

#### Connecting to the guest using VNC

Start the RealVNC application and type in the IP address of the *server* (your Linux system) followed by the port number the VNC server is running on it. Figure 4-32 on page 215 shows our VNC client connecting to our Linux guest system.

Enter the VNC server information according to the IP:port format. See Figure 4-32.

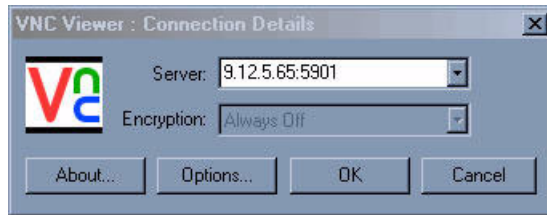

Figure 4-32 Connecting to the Linux system via VNC

**Note:** When you install SLES10 and enable VNC management, a VNC server will be running on port 5901 after the system boots up.

RealVNC opens a new window, which displays the X Window System. At this point, you probably do not see the KDM login manager; instead you see a blank X Window System.

To bring up the login manager, log in as `root` to the Linux guest through SSH and type the following text:

```
/etc/init.d/xdm start
```

Depending on your network speed, KDM can take awhile to be displayed in your current VNC display. The KDM login display is similar to the one in Figure 4-33 on page 216.

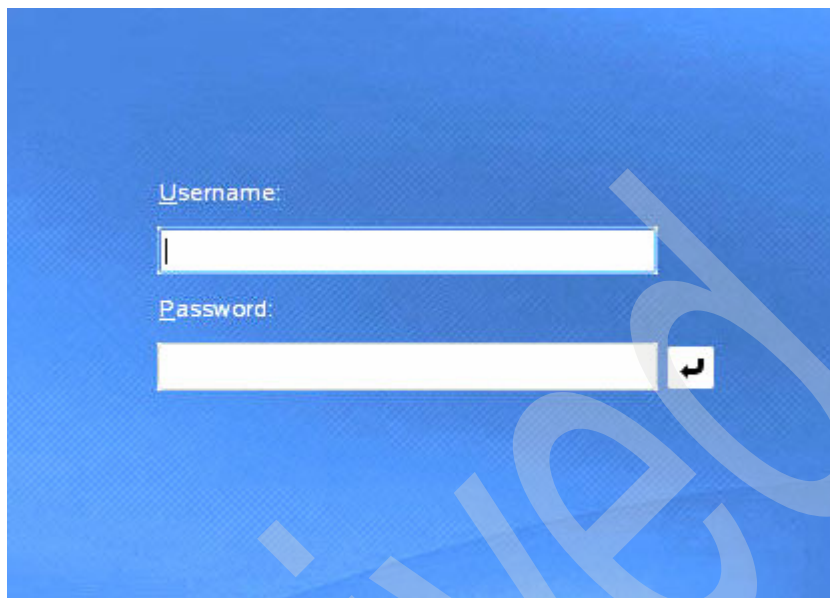

Figure 4-33 KDM login window

Log in as root and have a first look at your graphical KDE interface.

### Configuring KDM to autostart in boot

Starting the XDM service every time you want to log into the system with VNC is not desirable. Therefore, you should enable it as a system service in the run levels.

To configure KDM to autostart, use the following steps, which correspond to the numbers in Figure 4-34 on page 217:

1. Click the YaST icon
2. Scroll down and select **System** in the left menu.
3. After the menu on the right refreshes, scroll down and select **System Services (Runlevel)**.
4. Scroll down the list until you see an entry for xdm.



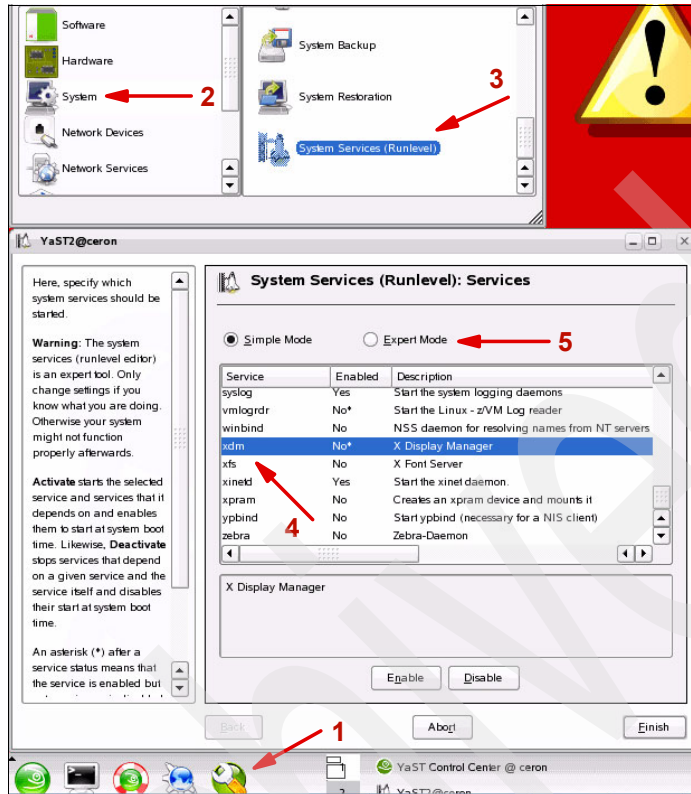

Figure 4-34 Enabling XDM as a system service.

5. Highlight the xdm line and click **Expert Mode**.

The window changes to an expert mode as shown in Figure 4-35 on page 218.

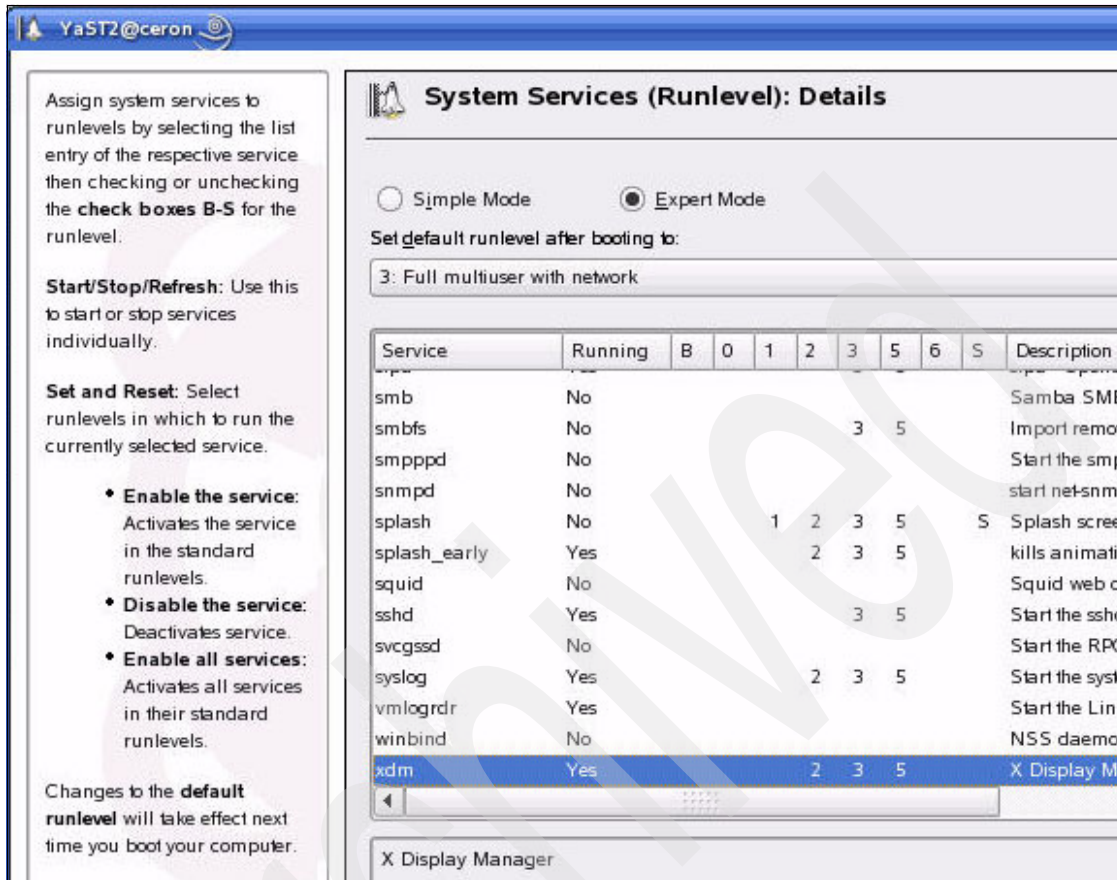

Figure 4-35 Runlevel editing in expert mode.

6. Enable XDM to be run on levels 2, 3 and 5. Click **Finish** to complete the process.

These steps should do the trick. The next time, and when you log in with a VNC client, you will see a KDM login window.

For more information about the peculiarities of a Linux installation, which we do not mention in this book, read the Gentoo handbook<sup>11</sup> at:

<http://www.gentoo.org/doc/en/handbook/index.xml>

<sup>11</sup> Although this is the handbook of a specific Linux distribution, the concepts behind a Linux installation are very well outlined and generic.

## 4.5 Running a z/OS image as a z/VM guest

The process of running a z/OS system as a guest of z/VM is much the same as running any other guest system. In this section, we discuss moving a z/OS image from a z10 LPAR to run as a z/VM guest operating system. This should work for systems on any System z processor. It could be the scenario for many sites because of LPAR constraints, server consolidation, or to simplify their test environment. One strength of z/VM is its ability to virtualize hardware in the form of (for instance) virtualized coupling facilities, channel-to-channel adapters and more. One could also manipulate the device addresses, thus minimizing the need for administration of the hardware configuration (IOCDs). The latter enables a quick and efficient path to set up new test images when desired.

This process is essentially the same as though a new z/OS system were being created to run as a z/VM guest. Determining the resources needed would still have to be planned and at the point where we IPL the existing z/OS system as a z/VM guest, the z/OS installation process would then be performed.

### 4.5.1 z/OS candidate description

The z/OS image we are moving from an LPAR to z/VM guest had specific resources defined for it. It had a SYSNAME of *SC59*, and you might want use that as your z/VM user ID, but it is not required. It had no CTCs and was not utilizing CFs or other hardware to take into account, in addition to communication through OSA adapter. It had a hardware configuration similar to the simplified listing in Table 4-2:

Table 4-2 Table of resources

Type of resource	Description	Comment
Sysname	SC59	Can be the z/VM user ID
Memory / CS	2 GB	Initial storage
Processors / CPs	4	—
DASD / Disks	53 volumes	3390 Mod 3 and Mod 9
OSA network adapter	2000-2005	QDIO
Console	Address F008	3270 console

## 4.5.2 Necessary definitions for z/VM

The resources listed in Table 4-2 on page 219 are the resources you have to define to the virtual machine in which you intend to bring up your z/OS image. Please observe that the table does not contain all the necessary details, for instance all the DASD disk device addresses.

## 4.5.3 Defining z/OS guest in USER DIRECT

After we obtained the necessary data about the z/OS image configuration, we logged on to our z/VM MAINT user ID and updated the z/VM USER DIRECT file (see sections 2.2.4, “User directory” on page 18 and “USER DIRECT file” on page 294).

**Note:** Naming your guest machines by using the corresponding z/OS sysname might make sense.

Figure 4-36 shows definitions for the z/OS guest.

```
USER SC59 GUESTZOS 2G 4G G
INCLUDE IBMDFLT
ACCOUNT ITS30000
IPL CMS PARM AUTOOCR
MACHINE ESA 4
OPTION MAINTCCW QUICKDSP
CONSOLE F008 3215
NICDEF 2000 TYPE QDIO DEVICES 6 LAN SYSTEM VSW1
MDISK 0191 3390 2390 2 LX6W02 MR
MDISK 813A 3390 0 END OP1TSA MWV
MDISK 8244 3390 0 END OP1HFC MWV
....
MDISK C730 3390 0 END IODFPK RR
MDISK D42A 3390 0 END Z19RF1 RR
```

1  
2  
3  
4  
5  
6  
7  
8  
9  
10  
11

Figure 4-36 USER DIRECT entry for the SC59 user id.

Description of the statements from the line numbering in Figure 4-36:

- 1 Establishes USER SC59 with a password of GUESTZOS. It is defined with 2 GB storage initially and 4 GB as a maximum, and defined as a privilege class G user (no special privileges).
- 2 Includes the PROFILE IBMDFLT (not shown here).

- 3 Provides accounting information.
- 4 IPLs CMS on logon, which automatically executes the PROFILE EXEC, if present. From the PROFILE EXEC, you could execute other execs.
- 5 Defines the mode for the guest. For this particular user, the architecture is ESA with up to 4 CPUs.
- 6 Establishes options for the guest user ID. MAINTCCW implies that the guest is allowed to initialize any DASD it uses. QUICKDSP causes the guest to be added to the dispatch list immediately when it has work to do without entering the eligible list.
- 7 Defines guest console address as the same address as the z/OS console. Note that it has to be defined as 3215 at this stage due to z/VM console requirements. It will be redefined to 3270 in order to IPL z/OS in the IPLSC59 EXEC (see Example 4-18 on page 225).
- 8 Defines a connection to a z/VM vswitch as an OSA device with six consecutive addresses starting at address 2000.
- 9 Defines the guest's minidisk in CMS. Used for CMS file system, for instance PROFILE EXEC (described later).
- 10, 11 Provides definitions of the DASD that z/OS requires. They are all defined as minidisks, starting in cylinder 0 and ending in the highest cylinder (the entire disk). In our case, the real address and the virtual address of every device is identical. The disk addresses could be defined using addresses other than the real ones to simplify configuration administration of test images. Note also that the disk is defined having an access mode of MWV, meaning Multi-Write access. The last V defines that CP should use its virtual reserve/release support for I/O operations for this minidisk. This is to ensure integrity if accessed from several guests. If there are shared read only DASDs, then access can be defined as read only (RR).

**Note:** Not all disks are listed, only a few examples are for illustration purposes. Additional minidisks are defined to guest *SC59*.

**Tip:** You may define minidisks with access mode of RR to prevent them from being updated, if that is desirable. This can be useful for preventing allocations or updates to certain disks (for instance your SYSRES or IODF disk) without adjusting any access rules in RACF or a similar product.

After the updates to the USER DIRECT file are done, save the file and issue the following DIRECTXA command to load the new directory into z/VM storage.

```
directxa user direct c
```

#### 4.5.4 ZOS1 guest console considerations

In this scenario, we choose not to use any channel-attached console to operate the image for simplicity. This implied that we could log on to the z/VM guest user ID, IPL the z/OS, and use that session as a z/OS operator console.

**Warning:** A concern is if the z/OS operator issues a CP LOGoff, the z/OS system will immediately terminate. A CP DISConnect should be used to keep the system running.

**Important:** When running z/OS as a z/VM guest, the HMC console cannot be used for IPLing the z/OS guest

This type of operation also implies that we need to change the mode for the operator console to 3270 prior to IPLing z/OS to avoid console lockouts, as 3270 is the supported terminal type in z/OS.

#### 4.5.5 SC59 guest PROFILE EXEC creation

We created a PROFILE EXEC file for guest user ID SC59 to define additional CPUs. You may add other definitions according to each installation's requirements. The PROFILE EXEC is executed each time an IPL of CMS is performed. This exec is also executed when a user ID is autologged onto the z/VM system. Reconnecting from a *disconnected* virtual machine does not execute the PROFILE EXEC.

Figure 4-37 shows the PROFILE EXEC file for the SC59 user ID.

```
PROFILE EXEC F1 V 130 Trunc=130

00000 * * * Top of File * * *
00001 /* PROFILE EXEC FOR SC59 */
00002 set pf12 ret
00003 'CP DEFINE CPU 1'
00004 'CP DEFINE CPU 2'
00005 'CP DEFINE CPU 3'
```

Figure 4-37 PROFILE EXEC for SC59

**Important:** By defining the PROFILE EXEC as we did, you could not AUTOLOG this machine and have the z/OS system IPL automatically. The file does not contain any statements to actually IPL the z/OS image.

Instead of placing the statements and commands necessary to perform an IPL of the z/OS image in the profile, we created an exec to actually perform this. In short, this exec performs the following tasks:

1. Switches the mode of the console to 3270
2. Issues command SET RUN ON
3. IPLs the z/OS image

The contents of the IPLSC59 EXEC is shown in Figure 4-38.

```
IPLSC59 EXEC      A1  V 130  Trunc=130 Size=14 Line=0 Col=1 Alt=2

00000 * * * Top of File * * *
00001 /* Exec to IPL the SC59 guest system */
00002 trace 'o'
00003 'vmfc1ear'
00004 cmd = 'TERM CONMODE 3270' || '15'X
00005 cmd = cmd || 'SET RUN ON' || '15'X
00006 say '*****'
00007 say '*                                     *'
00008 say '*   This is a z/OS 1.9 system,           *'
00009 say '*   WAIT, the system is coming up... SC59 *'
00010 say '*                                     *'
00011 say '*****'
00012 cmd = cmd || 'IPL D42A LOADPARM C73059M1 CLEAR'
00013 push cmd
00014 exit
00015 * * * End of File * * *
```

Figure 4-38 Contents of IPL

Significant items in the IPLSC59 exec are described in the following list:

- TERM CONMODE 3270** This switches the mode (or terminal type) to 3270.
- '15'x** This is the end-of-line indicator that occurs after each command. The commands themselves are stacked and are issued after the exec has ended (not controlled by any logic in the exec itself).

<b>SET RUN ON</b>	This is used to avoid the virtual machine entering CP read mode causing the z/OS to halt
<b>IPL D42A</b>	This is the actual IPL command for z/OS as normally entered in the HMC if you run z/OS in a LPAR.

**Note:** The following important statements or commands in the IPLSC59 EXEC, can all be issued as separate commands from the virtual machine itself, rather than executing the IPLSC59 EXEC:

- ▶ TERM CONMODE 3270
- ▶ SET RUN ON
- ▶ IPL D42A LOADPARM C73059M1 CLEAR

### 4.5.6 IPLing the system as a z/VM guest

After creating the previous files, we took down the z/OS system running in an LPAR. Then, we logged on to z/VM user ID, SC59, and ran the IPLSC59 EXEC. After a short while (like a normal IPL of an LPAR would), we saw the initial messages and our session appeared identical to a normal z/OS operator console. After we brought up all the necessary started-tasks and sub-systems, we issued a CP DISC command to disconnect from the system console, leaving the z/OS system running.

**Note:** One *peculiarity* in our way of defining the console, was that on the initial IPL, we had to prefix operator responses with #CP VINPUT VMSG to communicate with z/OS when in NIPCON mode; for instance:

```
#CP VINPUT VMSG R 00,CONTINUE
```

After entering the normal console mode, this was no longer true. This should not be necessary when operating physically attached consoles.

### 4.5.7 z/OS concerns

One thing to be aware of from a z/OS perspective, is any use of symbolics HWNAME and LPARNAME. If these are used in PARMLIB member (for instance your IEASYMxx) or in member LOADxx residing in PARMLIB or SYSn.IPLPARM, they would require your attention. The LPARNAME can never be resolved when running z/OS as a z/VM guest, so any filtering on values of these variables will fail. Depending on your incorporated logic, the IPL could fail because of this issue. If you have filters concerning HWNAME, you should consider whether to change it to VMUSERID instead. For details, refer *z/OS: MVS Initialization and Tuning Reference*, SA22-7592.



## 4.5.8 Adding a 3390 disk to the z/OS guest

As with any z/OS system running in an LPAR, there are occasions when additional I/O devices, such as DASD, are required by the system. In an LPAR, defining the new DASD in the IOCDS for that LPAR makes the new volumes available to the z/OS system. A similar capability exists when running a z/OS system as a z/VM guest. After the z/OS guest system was brought up, we went through a series of steps to bring online a new 3390 disk volume to the guest system without interrupting the system or requiring an IPL. We also decided to bring the *physical* device address 8222 online to the z/OS guest as device address 6000 as defined on z/OS. The disk had a volser of DK8222. The first thing we did was to add it as a minidisk for the guest user (in USER DIRECT file), as illustrated in Example 4-18.

*Example 4-18 USER DIRECT statement for z/OS guest user minidisk*

---

```
....  
MDISK 6000 3390 0 END DK8222 MWV
```

---

Issuing the DIRECTXA command loads the directory to z/VM storage

After adding the volume, while still logged on to MAINT, we issued the command to make the new DASD volume available to the z/VM system and guest users:

```
ATT 8222 SYSTEM
```

We then logged on to the guest z/OS user ID on z/VM. As this also acted as a operator console (see our assumption in 4.5.5, “SC59 guest PROFILE EXEC creation” on page 222, we pressed PA1 (or the keystrokes simulating it from our 3270 emulator) to enter CP read mode. We then issued the following command to make the new volume available to the z/OS system:

```
LINK * 6000 6000 MWV
```

This is illustrated Figure 4-39.



```
00: link * 6000 6000 mwv  
00: DASD 6000 LINKED R/W
```

*Figure 4-39 LINK command issued from z/OS guest user ID*

After clearing the CP window thus entering the z/OS operator console again, we observed this message.

```
IOS1501 DEVICE 6000 NOW AVAILABLE FOR USE
```

From the z/OS system console, we issued the following statement to verify that the status had not changed (caused by the fact that we now were running under z/VM):

```
D U,,,6000,1
```

Then we varied the device online from z/OS, see snapshot of the z/OS system log in Figure 4-40.

```
- 12.57.20 IOS1501 DEVICE 6000 NOW AVAILABLE FOR USE
- 12.57.58 d u,,,6000,1
  12.57.58 IEE457I 12.57.58 UNIT STATUS 147
  UNIT TYPE STATUS          VOLSER      VOLSTATE
  6000 3390 F-NRD              /RSDNT
- 12.58.10 v 6000,online
  12.58.10 IEE302I 6000      ONLINE
00- 12.58.24 d u,,,6000,1
  12.58.24 IEE457I 12.58.24 UNIT STATUS 153
  UNIT TYPE STATUS          VOLSER      VOLSTATE
  6000 3390 0                DK8222     PRIV/RSDNT
```

Figure 4-40 z/OS SYSLOG

This demonstration provides ideas for using z/VMs virtualization capabilities to manipulate device addresses as seen by z/OS. A possible scenario could be to have a relatively static hardware configuration (considering the IOCDs) for test z/OS images. By cloning a z/OS preconfigured system, you would be able to manipulate physical device addresses and their corresponding virtual addresses for each guest in z/VM, thus reducing the need for configuration changes.

# z/VM system operations

In this chapter, we introduce several common systems operations tasks for z/VM and Linux. In addition, we compare typical z/OS system operations with z/VM and Linux. We also provide pointers to resources about cloning systems.

## Objectives

After completing this chapter, you should be able to:

- ▶ Communicate with other z/VM users
- ▶ Understand the IPL and shutdown processes of z/VM
- ▶ Perform basic management of z/VM virtual machines
- ▶ Perform resource management
- ▶ Run processes similar to batch jobs

## 5.1 Using a console to communicate to users

Section 2.7, “Consoles” on page 50 discusses the types of consoles that z/VM has available. Using these consoles allows communication to other z/VM users.

You can communicate with z/VM users by sending:

- ▶ General information messages to all logged-on users
- ▶ General information messages to a specific user
- ▶ Warning messages to all logged-on users
- ▶ Warning messages to a specific user

**z/OS analogy:** z/OS users make use of the SEND command.

The MESSAGE and WARNING commands are limited by the length of the input command area. If the entire text of a message does not fit in this area, enter another command with the remaining text.

If an external security manager (ESM) is installed, you might not be authorized to use the MESSAGE or WARNING commands. However, messages sent to or from the system operator and messages sent with the ALL option are not subject to authorization checking by the ESM. For additional information, contact your security administrator.

If CP does not issue your message the way you entered it, it might be because you are including special line-editing symbols in the text of your message. For example, if logical line editing is in effect, the # symbol is your logical line-end symbol; if you include a # in your message text, CP cuts off your message. To prevent CP from interpreting these symbols as logical line-editing functions, enter the following command:

```
SET LINEDIT OFF
```

CP then issues your messages as you enter them.

### 5.1.1 Sending a general information message to all users

To send a general information message, such as “Query log for weekend schedule,” to all logged-on users, enter:

```
message all query log for weekend schedule
```

When Cross System Extensions<sup>1</sup> (CSE) is active and you want all users, logged on all systems in the CSE complex, to receive the message, enter:

```
message all at all query log for weekend schedule
```

The following message appears on the display window of all users able to receive the message:

```
hh:mm * MSG FROM OPERATOR: QUERY LOG FOR WEEKEND SCHEDULE
```

The hh:mm indicates the time the message was sent. Each user receives the message immediately unless:

- ▶ An action is pending at the user's display. In this case, the user receives the message when the action completes.
- ▶ The user is running in full-screen mode or has entered the SET MSG OFF command. In these cases, the user does not receive the message and you receive an error message.
- ▶ The user is not logged on.

### 5.1.2 Sending a general information message to a specific user

Sometimes, you have to send a general information message only to a specific user. For example, if you want to inform user VMUSER1 that he is not authorized to use pack RC015, which he just asked you to mount, enter the following command:

```
message vmuser1 you are not authorized to use pack rc015
```

When user VMUSER1 has no action pending at his display, the message appears on his display window (provided he is not running in full-screen mode or has not entered the SET MSG OFF command). Only VMUSER1 receives this message.

### 5.1.3 Sending a warning message to all users

Occasionally, a system problem requires you to take action, such as having to IPL the system, that would disrupt a user's virtual machine operation. When this happens, using the warning command will immediately interrupt the user's console with the urgent message, unlike the MESSAGE ALL, which informs all users of the situation:

```
warning all the system will be IPLed in 5 minutes, please log off.
```

---

<sup>1</sup> Reference for CSE in *z/VM: CP Planning and Administration* at:  
<http://publibz.boulder.ibm.com/epubs/pdf/hcsg0b21.pdf>

Another example is when CSE is active and you want all users, who are logged on all systems in the CSE complex, to receive the message, you might enter:

```
warning all at all the system will be IPLed in 5 minutes, please log off.
```

In response, CP displays the message on all user display windows within the next 60 seconds (provided users are not running in full-screen mode and have not entered the SET WNG OFF command). This should give them time to save what they are currently working on.

**Note:** If you use the MESSAGE command to send a warning, a user with an action pending does not receive it until that action completes, which could be too late.

### 5.1.4 Sending a warning message to a specific user

Sometimes, you have to send a high-priority message to a specific user. For example, user MVSOPR1 might submit a high-priority file that must be processed on printer 00E, but the printer is dedicated to user VMUSER1. Before you reassign the printer to user MVSOPR1, you might want to send user VMUSER1 the following warning message:

```
warning vmuser1 system needs printer 00e - draining in 5 minutes
```

If the user is not running in full-screen mode and has not entered the SET WNG OFF command, user VMUSER1 receives this message within the next 60 seconds and should stop sending files to this printer for processing.

## 5.2 Running the system

This section explains what happens in your z/VM system when it is brought up and when it is taken down. Having knowledge of the IPL and shutdown process for systems monitoring and problem debugging is very helpful.

### 5.2.1 z/VM IPL workflow

When you IPL your z/VM system, many steps have to be performed during the IPL before it is fully functional and ready for use. Figure 5-1 on page 231 shows the flow of these steps.

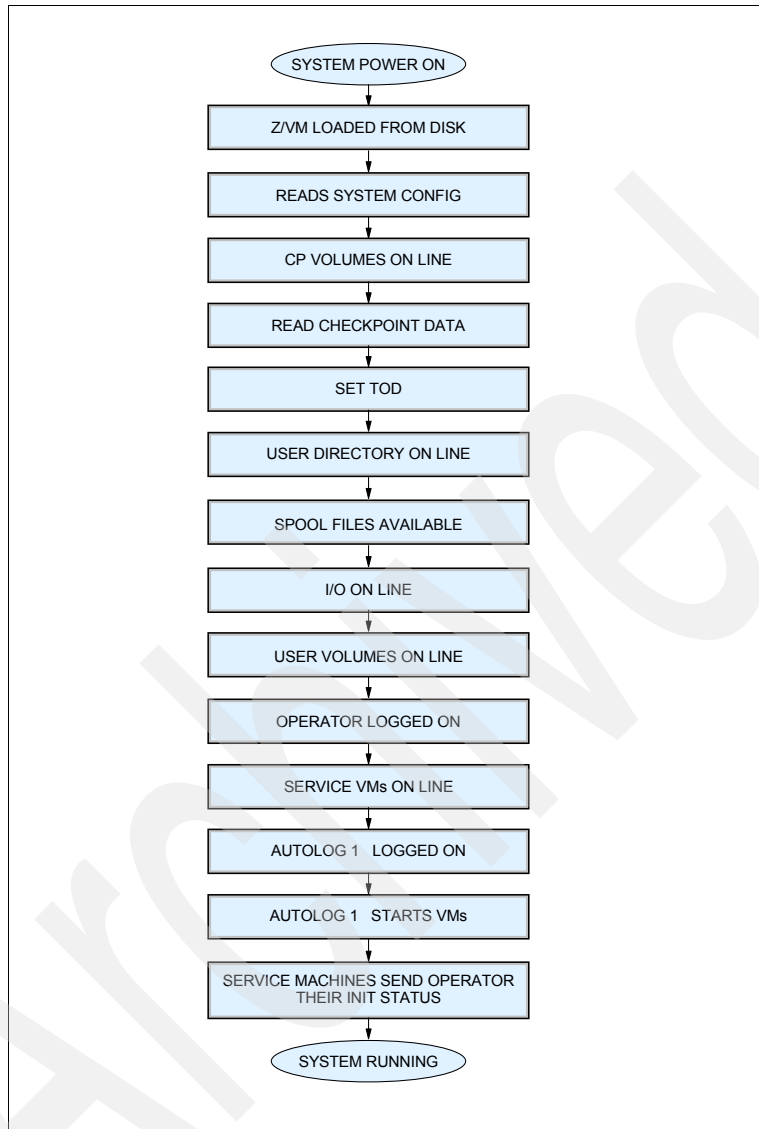

Figure 5-1 z/VM IPL flowchart

From top to bottom in the z/VM IPL flowchart, the steps are:

1. The z/VM operating system is loaded from disk. This comprises the system CP nucleus.
2. The CP reads the SYSTEM CONFIG file to identify configuration parameters and implement them.

3. The operating system brings the CP owned volumes online, such as those used for paging, spool, and t-disk.
4. Depending on how it was started (see 5.2.2, “Warm start, force start, cold start, and clean start” on page 234), z/VM reads the information about systems attributes saved in the checkpoint and warm start data files<sup>2</sup> during last the shutdown and restores them.
5. System prompts for set up of time-of-day (TOD).
6. The user directory, with the user’s definitions, is brought online.
7. Existing spool files are made available.
8. All connected I/O is brought online and made available.
9. User volumes defined in SYSTEM CONFIG are made available.
10. The OPERATOR user is logged on.
11. The OPERATOR virtual machine starts the logging/accounting/symptom services by logging on the erep, diskacnt and opersymp users.
12. The OPERATOR user ID autologs AUTOLOG1.
13. AUTOLOG1 starts any other virtual machine that it has been instructed to start according to its PROFILE EXEC.
14. Services machines send messages to OPERATOR on initialization status.

Example 5-1 shows the output of a z/VM IPL process. Interactions with the console are in **bold**.

*Example 5-1 z/VM IPL process.*

---

```

14:58:30 z/VM V5 R3.0 SERVICE LEVEL 0703 (64-BIT)
14:58:31 SYSTEM NUCLEUS CREATED ON 2008-05-23 AT 10:40:19, LOADED FROM LX6RES
14:58:31
14:58:31 *****
14:58:31 * LICENSED MATERIALS - PROPERTY OF IBM* *
14:58:31 * * *
14:58:31 * 5741-A05 (C) COPYRIGHT IBM CORP. 1983, 2007. ALL RIGHTS *
14:58:31 * RESERVED. US GOVERNMENT USERS RESTRICTED RIGHTS - USE, *
14:58:31 * DUPLICATION OR DISCLOSURE RESTRICTED BY GSA ADP SCHEDULE *
14:58:31 * CONTRACT WITH IBM CORP. *
14:58:31 * * *
14:58:31 * * TRADEMARK OF INTERNATIONAL BUSINESS MACHINES. *
14:58:31 *****
14:58:31
14:58:31 HCPZC06718I Using parm disk 1 on volume LX6RES (device 1B34).
14:58:31 HCPZC06718I Parm disk resides on cylinders 39 through 158.
14:58:31 Start ((Warm|Force|COLD|CLEAN) (DRain) (DIsable) (NODIRect)

```

<sup>2</sup> This file is stored in the system RES volume



```

14:58:31      (NOAUTolog)) or (SHUTDOWN)
14:58:59 WARM
14:58:59 NOW 14:58:59 EDT THURSDAY 2008-06-05
14:58:59 Change TOD clock (Yes|No)
14:59:03 NO
14:59:03 The directory on volume LX6RES at address 1B34 has been brought
online.
14:59:05 HCPWRS2513I
14:59:05 HCPWRS2513I Spool files available      376
14:59:07 HCPWRS2512I Spooling initialization is complete.
14:59:07 DASD 1B35 dump unit CP IPL pages 17646
14:59:07 HCPAAU2700I System gateway VMGUEST identified.
14:59:07 z/VM Version 5 Release 3.0, Service Level 0703 (64-bit),
14:59:07 built on IBM Virtualization Technology
14:59:07 There is no logmsg data
14:59:07 FILES: 0031 RDR, 0009 PRT,   NO PUN
14:59:07 LOGON AT 14:59:07 EDT THURSDAY 06/05/08
14:59:07 GRAF 0020 LOGON AS OPERATOR USERS = 1
14:59:07 HCPIOP952I 2048M system storage
14:59:07 FILES: 0000314 RDR, 0000030 PRT, 0000001 PUN
14:59:07 HCPCRC8082I Accounting records are accumulating for userid DISKACNT.
14:59:07 XAUTOLOG EREP
14:59:07 Command accepted
14:59:07 XAUTOLOG DISKACNT
14:59:07 Command accepted
14:59:07 XAUTOLOG AUTOLOG1
14:59:07 Command accepted
14:59:07 XAUTOLOG OPERSYMP
14:59:07 Command accepted
14:59:07 AUTO LOGON ***      EREP      USERS = 2      BY OPERATOR
14:59:07 AUTO LOGON ***      DISKACNT USERS = 3      BY OPERATOR
14:59:07 AUTO LOGON ***      AUTOLOG1 USERS = 4      BY OPERATOR
14:59:07 AUTO LOGON ***      OPERSYMP USERS = 5      BY OPERATOR
14:59:07 HCPCLS6056I XAUTOLOG information for EREP: The IPL command is verified
by the IPL command processor.
14:59:07 HCPCLS6056I XAUTOLOG information for DISKACNT: The IPL command is
verif
ied by the IPL command processor.
14:59:07 HCPCLS6056I XAUTOLOG information for AUTOLOG1: The IPL command is
verif
ied by the IPL command processor.
14:59:07 HCPCLS6056I XAUTOLOG information for OPERSYMP: The IPL command is
verif
ied by the IPL command processor.
14:59:07 AUTO LOGON ***      VMSERVS USERS = 6      BY AUTOLOG1
14:59:07 AUTO LOGON ***      VMSERVU USERS = 7      BY AUTOLOG1
14:59:07 AUTO LOGON ***      VMSERVR USERS = 8      BY AUTOLOG1
14:59:07 USER DSC  LOGOFF AS AUTOLOG1 USERS = 7
14:59:07 AUTO LOGON ***      DTCVSW1 USERS = 8      BY AUTOLOG1

```

```
14:59:07 AUTO LOGON ***      DTCVSW2  USERS = 9      BY AUTOLOG1
14:59:07 AUTO LOGON ***      TCPIP    USERS = 10     BY AUTOLOG1
14:59:07 * MSG FROM EREP :1 RECORDING FILE(S), 40 RECORDS, A DISK 03 % FU
LL
14:59:07 * MSG FROM DISKACNT:17 RECORDING FILE(S),1097 RECORDS, A DISK 27 %
FULL
14:59:07 HCPCRC8064I Recording data retrieval has been started; recording
*LOGREC for userid EREP.
14:59:07 HCPCRC8064I Recording data retrieval has been started; recording
*ACCOUNT for userid DISKACNT.
14:59:07 * MSG FROM OPERSYMP: 26 RECORDING FILE(S), 26 RECORDS, A DISK 04 %
FULL
14:59:07 HCPCRC8064I Recording data retrieval has been started; recording
*SYMPTOM for userid OPERSYMP.
14:59:08 3020-3022 ATTACHED TO TCPIP BY TCPIP
14:59:08 AUTO LOGON ***      FTPSERVE USERS = 11     BY TCPIP
```

---

## 5.2.2 Warm start, force start, cold start, and clean start

z/VM provides you with four basic types of starts: *warm*, *force*, *cold*, and *clean*. The difference among them is in how much of the system's environment CP restores, with a warm start restoring the most and a clean maintaining the least.

If a warm start fails, contact your system support personnel before you use a force or cold start since critical files could be lost.

To restore the system's environment, you must save it first. When you issue a SHUTDOWN command and receive the response, SHUTDOWN COMPLETE, then CP saves the following parts of the system's environment:

- ▶ Any accounting, EREP<sup>3</sup>, and symptom records in storage  
Accounting, EREP, and virtual machines that are symptom record recording services normally transfer these records from storage to disk. If these virtual machines are not retrieving, the records remain in storage. The SHUTDOWN command writes any records that are still in storage into the checkpoint area on DASD so that during the next IPL the records can be returned to storage for retrieval.
- ▶ System log message  
The system log message communicates information to users when they log on or reconnect.
- ▶ Spool file queues

---

<sup>3</sup> EREP: Environmental Record Editing and Printing. EREP reads error and other environmental records generated by hardware and software, edits the records and produces printed reports.

Spool files are collections of data on disk and are waiting to be processed by real or virtual readers, printers, or punches. The SHUTDOWN command saves information about the queues that locate these spool files.

**Note:** Spool files might not be restored in the same order following a warm or force start.

**z/OS analogy:** The z/VM SHUTDOWN command is similar to the HALT (Z E0D) command, except that z/OS does not keep warm data.

► System data file queues

The system data file queues hold the following collections of data, called *system data files*: named saved systems (NSSs), discontinuous saved segments (DCSSs), image libraries, user class restructure (UCR) files, message repository files, and system trace files.

- A named saved system (NSS) is a copy of an operating system that a user has named and retained in a system data file. The user can load the operating system by its name, which is more efficient than loading it by device number.
- A discontinuous saved segment (DCSS) refers to one or more pages of storage that a user has named and retained in a system data file. When a discontinuous saved segment, defined as shareable, is loaded, more than one user can access it.
- An image library is a set of modules, contained in a system data file, that define the spacing, characters, and copy-modification data that a printer uses to print a spool file.
- User class restructure (UCR) files expand the privilege classes of commands and DIAGNOSE codes. This lets your installation customize the privilege class structure of z/VM.
- Message repository files contain z/VM messages and responses translated into a national language.
- System trace files contain records of events that occur within the system. Use these files to determine the source of problems in the system.

The SHUTDOWN command saves information about the queues that locate these system data files.

► The status of unit record devices, displays, and 3270 printers

When you enter the SHUTDOWN command, you save all these parts of the system's environment. Then, when you bring the system back up with a warm start, CP restores them.

If you enter the SHUTDOWN REIPL command, CP attempts to do an automatic start of the specified module.

See the *z/VM: CP Commands and Utilities Reference*, SC24-6081<sup>4</sup> for other restrictions when you re-IPL another module.

Unless you have a reason to do otherwise, specify a warm start. Keep in mind that if you do not shut down the z/VM system with the SHUTDOWN command, you might not be able to bring it back up with a warm start. The information that the SHUTDOWN command saves is what allows a warm start to work.

During a force start, CP tries to restore most of what it restores during a warm start, but it might not be able to do it completely. Just as in a warm start, CP tries to restore, in the following order:

1. Accounting, EREP, and symptom records in storage
2. System log message
3. Spool file and system data file queues

However, if CP encounters an error during the first step, it immediately goes on to recover the spool file and system data file queues. Unless you specified the following statement in the system configuration file, the system log message is lost:

```
FEATURES ENABLE LOGMSG_FROM_FILE
```

Any remaining accounting, EREP, and symptom records are lost. Further, if CP encounters an error while recovering a spool file, it immediately goes on to the next file in the queue, and the file on which the error occurred is scheduled to be deleted. When the preliminary phase of spooling initialization is complete, a message providing spool file summary status is displayed, and the operator can then stop system initialization without the loss of any spool files.

Also, a force start does not restore any of the unit record device characteristics, such as the class to be processed or the image library. Instead, a force start tries to start the unit record devices with the default characteristics specified on the RDEVICE statement in the system configuration file. A force start does try to restore the status of all displays and 3270 printers.

---

<sup>4</sup> <http://publib.boulder.ibm.com/infocenter/zvm/v5r3/index.jsp?topic=/com.ibm.zvm.v53.hcp/b7/hcse4b21.htm>

Therefore, after a force start, CP might not have completely recovered all of the system's environment. Use a force start only when authorized by the system support personnel after a warm start fails.

If a force start fails, you must perform a *cold* start. During a cold start, CP tries to recover *only* the system data files. This means that when you perform a cold start, you lose all of your spool files, all accounting, EREP, and symptom records in storage. The system log message is lost if you did not specify the following statement in the system configuration file:

```
FEATURES ENABLE LOGMSG_FROM_FILE
```

The status of your unit record devices, displays, and 3270 printers can also differ from their status before the restart. Use a cold start only when both a warm start and a force start fail.

The essential points to grasp about warm starts, force starts, cold starts, and clean starts are:

- ▶ To save the system's environment before you restart it, use the SHUTDOWN command.
- ▶ To restore the system's environment, bring the system back up with a warm start.
- ▶ If a warm start fails,
  - Check the DASD volumes.
  - Contact system support personnel.
  - When repeated attempts to perform a warm start fail, try a force start to restore as much of the system's environment as possible.
- ▶ If you decide to continue with system initialization even though there are files scheduled to be deleted, remember that those files cannot be recovered.
- ▶ If a force start fails, try a cold start.
- ▶ A clean start IPLs the system without attempting to recover spool files and system data files that existed prior to system shutdown.

### 5.2.3 Checking system resources

After your system has started, check its resources. This section discusses various commands that assist you in checking your system resources and system availability.

## Checking system level: query cplevel and query cmslevel

The QUERY CPLEVEL and QUERY CMSLEVEL commands are useful for ensuring maintenance has been correctly applied on each system. The commands can be used to check the following items:

- ▶ Software version level, release level, and release modification level
- ▶ Software service level number
- ▶ Date and time (translated to the current active time zone) that CP system software was written to DASD
- ▶ Date and time CP was last started
- ▶ Release and service level of CMS

An example of the commands is shown in Example 5-2.

### *Example 5-2 Checking CP and CMS levels*

---

#### **q cplevel**

z/VM Version 5 Release 3.0, service level 0701 (64-bit)  
Generated at 05/29/07 23:21:12 EDT  
IPL at 06/11/08 07:58:34 EDT  
Ready; T=0.01/0.01 11:45:20

#### **q cmslevel**

CMS Level 23, Service Level 701  
Ready; T=0.01/0.01 11:45:24

---

## Checking CP load parameters: query cpload

Use QUERY CPLOAD, shown in Example 5-3, to display information regarding the last CP IPL. The information displayed includes the location of the CP module that was last used, the location of the parm disk, and how CP was started.

### *Example 5-3 Querying CPLOAD*

---

#### **q cpload**

Module CPLOAD was loaded from minidisk on volume LX6RES at cylinder 39.  
Parm disk number 1 is on volume LX6RES, cylinders 39 through 158.  
Last start was a system IPL.  
Ready; T=0.01/0.01 11:46:07

---

## Checking the amount of real storage: query storage

The QUERY STORAGE command (abbreviated as **Q ST0**) is used to display the amount of real memory that is available to an LPAR after it is started. See Example 5-4 on page 239.

*Example 5-4 Checking the amount of real storage available in the LPAR*

---

```
q stor
STORAGE = 4G
Ready; T=0.01/0.01 11:46:44
```

---

### **Checking the amount of expanded storage: query xstorage**

The QUERY XSTORAGE command (abbreviated as **Q XSTO**) is used to display the amount of real expanded storage configured in a partition. The output of the command also shows the amount of expanded storage in use, and the amount used for minidisk caching (MDC). See Example 5-5.

*Example 5-5 Checking the amount of expanded storage available in the LPAR*

---

```
q xstor
XSTORE= 2048M online= 2048M
XSTORE= 2048M userid= SYSTEM usage= 0% retained= 0M pending= 0M
XSTORE MDC min=0M, max=0M, usage=0%
XSTORE= 2048M userid= (none) max. attach= 2048M
Ready; T=0.01/0.01 11:47:27
```

---

### **Checking all processors are available: query processors**

The QUERY PROCESSORS command (abbreviated as **Q PROC**), is used to display the current assignment of processors of the partition.

The MASTER processor is the base processor, used for IPL, ALTERNATE processors are automatically brought online at IPL, and STANDBY processors are available to the partition, but offline. See Example 5-6. The last field in the PROCESSOR lines indicate the type of processor: CP, an IFL, ICF, ZIIP or ZAAP.

*Example 5-6 Checking the numbers and types of CPUs available to the LPAR*

---

```
q processors
PROCESSOR 00 MASTER CP
PROCESSOR 01 ALTERNATE CP
PROCESSOR 02 ALTERNATE CP
PROCESSOR 03 ALTERNATE CP
PROCESSOR 04 STANDBY CP
PROCESSOR 05 STANDBY CP
Ready; T=0.01/0.01 11:51:31
```

---

### **Changing the availability of processors to the system**

Under normal circumstances, you bring up and run the system with all the processors in the processor complex or partition. However, if support personnel

at your installation instruct you to do so, you may use the VARY ONLINE PROCESSOR or VARY OFFLINE PROCESSOR commands to control whether a processor is available to z/VM. For more information about these commands, see the *z/VM: CP Commands and Utilities Reference*, SC24-6081<sup>5</sup>.

### Checking the system DASD configuration: query a1loc

After the system has IPLed, a good practice is to check that the required paging and spooling are available and online. You can also check temporary disk space.

The QUERY ALLOC PAGE retrieves paging space configuration. In Example 5-7, four 3390-03 (each are 3339 cylinders) have been configured as paging devices. Only 13 pages in total are allocated on these paging devices.

*Example 5-7 Checking the paging space available in the LPAR*

---

```

q a1loc page

```

VOLID	RDEV	EXTENT START	EXTENT END	TOTAL PAGES	PAGES IN USE	HIGH PAGE	% USED
LX6PAG	1A22	1	3338	600840	0	0	0%
DK8226	8226	0	3338	601020	0	0	0%
DK8227	8227	0	3338	601020	13	26	1%
DK8228	8228	0	3338	601020	0	0	0%
SUMMARY				2348K	13		1%
USABLE				2348K	13		1%

Ready; T=0.01/0.01 11:54:40

---

Similarly, the QUERY ALLOC SPOOL command checks the spooling configuration. In Example 5-8, only one 3390-03 DASD is defined as a spooling device, and 140075 pages are in use, representing around 23% of the total pages available for spooling.

*Example 5-8 Checking the spool space*

---

```

q a1loc spool

```

VOLID	RDEV	EXTENT START	EXTENT END	TOTAL PAGES	PAGES IN USE	HIGH PAGE	% USED
LX6SPL	1A21	1	3338	600840	140075	145430	23%
SUMMARY				600840	140075		23%
USABLE				600840	140075		23%

Ready; T=0.01/0.01 11:55:39

---

<sup>5</sup> <http://publibz.boulder.ibm.com/epubs/pdf/hcse4b21.pdf>



Finally, the QUERY ALLOC TDISK displays all defined and assigned temporary disk space, as shown in Example 5-9.

*Example 5-9 Checking the amount of TDISK allocated*

---

**q alloc tdisk**

VOLID	RDEV	EXTENT START	EXTENT END	TOTAL	IN USE	HIGH	% USED
LX6TDK	8225	1	3338	3338	20	20	1%
SUMMARY				3338	20		1% CKD
USABLE				3338	20		1% CKD

Ready; T=0.01/0.01 11:06:01

---

### Checking system dump space configuration: query dump

The QUERY DUMP command (abbreviated **Q DUMP**), in Example 5-10, shows:

- ▶ The device type and unit or units assigned to receive CP abnormal termination dumps
- ▶ The current settings of the DUMP options

*Example 5-10 Querying the DUMP configuration*

---

**q dump**

DASD 1A21 dump unit CP IPL pages 31437  
Ready; T=0.01/0.01 11:57:09

---

### Checking the recording status: query recording

The QUERY RECORDING command (abbreviated as **Q REC**) checks the status of the following items:

- ▶ CP data collection for these records:
  - Accounting
  - EREP (errors recording)
- ▶ CP data collection for symptom records
- ▶ Active retrieval of these records

In Example 5-11 on page 242, all recordings are active, using the defaults user IDs defined in z/VM: EREP userid for error recording, ACCOUNT for accounting information, and OPERSYMP for symptoms records gathering. The count field shows any unprocessed records.

*Example 5-11 Status of recordings in z/VM*

---

```
q rec
RECORDING    COUNT      LMT USERID  COMMUNICATION
EREP        ON 00000000 002 EREP    ACTIVE
ACCOUNT     ON 00000000 020 DISKACNT ACTIVE
SYMPTOM     ON 00000000 002 OPERSYMP ACTIVE
Ready; T=0.01/0.01 11:57:36
```

---

### Checking real devices availability

After z/VM has IPLed, the system operator checks that all resources allocated and defined in the configuration have been brought online.

#### ***Disks devices: query DASD a11***

The QUERY DASD ALL command (abbreviated as **Q DA ALL**) displays the list of all real disks active in the partition, their owner (CP, SYSTEM, or FREE if they are not attached), their label, and the number of links to MDISKs defined on the volume. The last line informs that there are no offline DASDs. The QUERY DASD command displays all DASDs in use by the system. See Example 5-12.

*Example 5-12 Querying all disks attached to the system.*

---

```
q da a11
DASD 1A20 CP OWNED LX6RES 80
DASD 1A21 CP OWNED LX6SPL 1
DASD 1A22 CP OWNED LX6PAG 0
DASD 1A23 CP OWNED LX6W01 127
DASD 1A24 CP OWNED LX6W02 4
DASD 1A25 CP SYSTEM NW1A25 1
DASD 1A26 CP SYSTEM NW1A26 1
DASD 1A27 CP SYSTEM NW1A27 1
DASD 1A28 CP SYSTEM NW1A28 1
DASD 1A29 CP SYSTEM NW1A29 1
DASD 1A2A CP SYSTEM NW1A2A 1
DASD 1A2B CP SYSTEM NW1A2B 1
DASD 1A2C CP SYSTEM NW1A2C 1
DASD 1A2D CP SYSTEM NW1A2D 1
DASD 8221 CP SYSTEM DK8221 1
DASD 8226 CP OWNED DK8226 0
DASD 8227 CP OWNED DK8227 0
DASD 8228 CP OWNED DK8228 0
DASD D815 CP SYSTEM LXD815 2
DASD D816 CP SYSTEM LXD816 1
DASD 1B34 LX6RES , DASD 1B35 LX6SPL , DASD 1B36 LX6PAG , DASD 1B37 LX6W01
DASD 1B38 LX6W02 , DASD 8222 DK8222 , DASD 8223 LX8223 , DASD 8224 DK8224
DASD 8225 LX8225 , DASD D817 LXD817 , DASD D818 LXD818 , DASD D819 LXD819
DASD D81A LXD81A , DASD D81B LXD81B , DASD D81C LXD81C , DASD D81D LXD81D
```

DASD D81E LXD81E , DASD D81F LXD81F  
An offline DASD was not found.  
Ready; T=0.01/0.01 11:58:00

---

### **Magnetic tape drives: query tape**

The QUERY TAPE command (abbreviated as Q TA) displays the status of the magnetic tape drives available to the system and assigned for use. See Example 5-13. QUERY TAPE ALL displays all tape drives available to the system. Checking the status of real tape drives.

*Example 5-13 Displaying the status of the tape drives*

---

#### **q tape**

An active tape was not found.  
Ready; T=0.01/0.01 11:58:29

---

### **Real Channel to channel adapters: query ctca**

The QUERY CTCA command can check the status of real channel-to-channel adapters available to the system and in use. See Example 5-14. The QUERY CTC ALL command displays all available CTC devices.

*Example 5-14 Querying real CTC adapters*

---

#### **q ctc**

An active CTCA was not found.  
Ready; T=0.01/0.01 12:00:26

---

### **Real OSA devices: query osa**

The QUERY OSA ALL command displays the list of real OSA devices. See Example 5-15. The QUERY OSA command displays the OSA devices in use. For each device, the following information is displayed:

- ▶ Virtual machine to which they are dedicated
- ▶ Virtual device number used in the virtual machine configuration to refer to the real OSA device
- ▶ Type of the device (HIPER, OSA)
- ▶ Channel path identifier (CHPID) to use to access the device, as well as its type.

*Example 5-15 Displaying the status of real OSA devices attached to the partition*

---

#### **q osa all**

OSA	3020	ATTACHED TO TCPIP	3020	DEVTYPE OSA	CHPID 0C OSD
OSA	3021	ATTACHED TO TCPIP	3021	DEVTYPE OSA	CHPID 0C OSD
OSA	3022	ATTACHED TO TCPIP	3022	DEVTYPE OSA	CHPID 0C OSD

```

OSA 3024 ATTACHED TO DTCVSW2 3024 DEVTYPE OSA        CHPID OC OSD
OSA 3025 ATTACHED TO DTCVSW2 3025 DEVTYPE OSA        CHPID OC OSD
OSA 3026 ATTACHED TO DTCVSW2 3026 DEVTYPE OSA        CHPID OC OSD
OSA 3028 ATTACHED TO DTCVSW1 3028 DEVTYPE OSA        CHPID OC OSD
OSA 3029 ATTACHED TO DTCVSW1 3029 DEVTYPE OSA        CHPID OC OSD
OSA 302A ATTACHED TO DTCVSW1 302A DEVTYPE OSA        CHPID OC OSD
OSA 3023 FREE      , OSA 3027 FREE      , OSA 302B FREE      , OSA 302C FREE
OSA 302D FREE      , OSA 302E FREE      , OSA 302F FREE
An offline OSA was not found.
OSA 302F is an OSA Agent
Ready; T=0.01/0.01 12:00:51

```

---

### Displaying running users: query names

To check whether the required users have been correctly auto-logged, a system operator can use the QUERY NAMES command (abbreviated as **Q N**). See Example 5-16. This command shows the list of virtual machines currently running in the system, and their status, as follows:

- ▶ DSC: the machine is running disconnected
- ▶ L0003: the machine is logged on

The VSM machine is the user ID of the VTAM service machine, managing the TCPIP user.

#### *Example 5-16 Displaying running users*

```

q n
LNKKEN - DSC , LNXGUI - DSC , LNXCER - DSC , FTPSERVE - DSC
TCPIP  - DSC , DTCVSW2 - DSC , DTCVSW1 - DSC , VMSERVR - DSC
VMSERVU - DSC , VMSERVS - DSC , OPERSYMP - DSC , DISKACNT - DSC
EREP   - DSC , OPERATOR - SYSC, MAINT   -L0003
VSM    - TCPIP
Ready; T=0.01/0.01 12:02:00

```

---

### Network status: ifconfig and netstat

The IFCONFIG and NETSTAT networking commands reside on TCPMAINT's 592 disk. The system operator must link to that disk before issuing these commands.

The IFCONFIG command shows the status of your TCP/IP network, including IP address, netmask, and amounts of data transferred. See Example 5-17.

#### *Example 5-17 Showing the status of TCP/IP network*

```

ifconfig
OSA3020 inet addr: 9.12.4.89 mask: 255.255.252.0

```

```
UP BROADCAST MULTICAST MTU: 1500
vdev: 3020 type: QDIO ETHERNET portname: UNASSIGNED
ipv4 router type: NONROUTER ipv6: DISABLED
cpu: 0 forwarding: ENABLED
RX bytes: 35296690 TX bytes: 3354354
Ready; T=0.01/0.01 13:43:59
```

---

The NETSTAT commands show more detailed information about the system's network. Issuing **NETSTAT?** displays all the command options and a brief explanation of each. As an example, the NETSTAT GATE command displays the network gateway information, as shown in Example 5-18.

*Example 5-18 Displaying network gateway information*

---

#### **netstat gate**

VM TCP/IP Netstat Level 530

Known IPv4 gateways:

Subnet	Address	Subnet Mask	FirstHop	Flgs	PktSz	Metric	Link
Default		<none>	9.12.4.1	UGS	1500	<none>	OSA3020
9.12.4.0		255.255.252.0	<direct>	UT	1500	<none>	OSA3020

Known IPv6 gateways: None

Ready; T=0.01/0.01 13:55:46

---

### **Checking system workload: indicate**

The INDICATE LOAD command (abbreviated as **IND LOAD**) command gives an overview of the system resources uses. When issued from a class B user, the output is as shown in Example 5-19. The first line shows the average processor utilization, and the overall number of CPU in the system. Next three lines displays usage of expanded storage, minidisk cache and paging activity. Next four lines displays the number of users in each of the four queues.

The last lines displays the current processor utilization. The system shown in the example was obviously doing nothing.

*Example 5-19 Overview of system resources utilization*

---

#### **ind load**

```
AVGPROC-000% 04
XSTORE-000000/SEC MIGRATE-0000/SEC
MDC READS-000000/SEC WRITES-000000/SEC HIT RATIO-000%
PAGING-0/SEC STEAL-000%
```

Q0-00001(00000) DORMANT-00011  
Q1-00000(00000) E1-00000(00000)  
Q2-00000(00000) EXPAN-001 E2-00000(00000)  
Q3-00006(00000) EXPAN-001 E3-00000(00000)

PROC 0000-000% CP PROC 0001-000% CP  
PROC 0002-000% CP PROC 0003-000% CP

LIMITED-00000

---

## 5.2.4 z/VM shutdown workflow

When a z/VM system goes down, important steps take place. Some of them are the opposite of the IPL steps (in 5.2.1, “z/VM IPL workflow” on page 230), but are complementary. For example, saving the system attributes in the checkpoint data file. Figure 5-2 depicts the process.

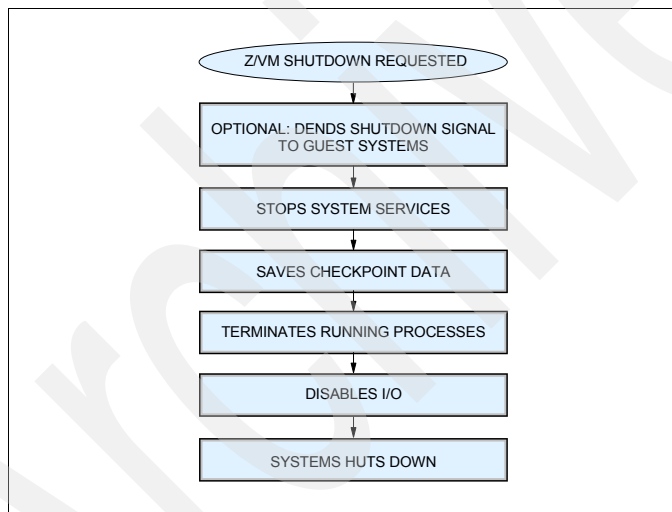

Figure 5-2 z/VM shutdown flowchart

From top to bottom in the z/VM shutdown flowchart, the steps are:

1. z/VM sends shutdown signals to guest systems (except for z/OS guests) requesting them to shut down. This allows guest system to cleanly shut themselves down before the entire system is shut off. This feature must be enabled in the SYSTEM CONFIG file (read “Starting virtual switches automatically at system startup” on page 175).
2. The system cleanly stops system services, such as logging and accounting.
3. z/VM saves the system attributes in the checkpoint data file on its RES volume.

4. All running processes are terminated.
5. z/VM disables of the I/O devices.
6. The running system is terminated.

Example 5-20 shows the output of a z/VM shutdown process.

*Example 5-20 z/VM shutdown process.*

---

```

00: 14:54:42 HCPWRP963I SHUTDOWN STEP USOAC - JOURNAL USER TERMINATION
00: 14:54:43 HCPWRP963I SHUTDOWN STEP MFRSD - TERMINATE HARDWARE LOADER
00: 14:54:43 HCPWRP963I SHUTDOWN STEP APISD - TERMINATE OTHER PROCESSORS
00: 14:54:44 HCPWRP963I SHUTDOWN STEP ENASD - DISABLE TERMINAL DEVICES
00: 14:54:45 HCPWRP963I SHUTDOWN STEP ISHDN - SHUT DOWN I/O SUBSYSTEM
00: 14:54:45 HCPWRP963I SHUTDOWN STEP TTRAL - TERMINATE CONCURRENT COPY
SESSIONS
00: 14:54:46 HCPWRP963I SHUTDOWN STEP SVACV - ACTIVATE TERMINATION SAVE
AREAS
00: 14:54:46 HCPWRP963I SHUTDOWN STEP CHMOF - DISABLE CHANNEL MEASUREMENT
00: 14:54:47 HCPWRP963I SHUTDOWN STEP ISHDA - DISABLE ALL DEVICES
00: 14:54:47 HCPWRP963I SHUTDOWN STEP CKPSH - TAKE A CHECKPOINT
00: 14:54:48 HCPWRP963I SHUTDOWN STEP OPRCK - SAVE OPERATOR CONSOLE LIST
00: 14:54:48 HCPWRP963I SHUTDOWN STEP MCWMD - DETERMINE MACHINE CHECK
STATUS
00: 14:54:49 HCPWRP963I SHUTDOWN STEP SDVRS - RESET IBM DASD CU
CHARACTERISTICS
00: HCPWRP962I VM SHUTDOWN COMPLETED IN 10 SEC
00: 14:54:49 HCPWRP963I SHUTDOWN STEP SVADV - DEACTIVATE TERMINATION SAVE
AREAS
00: 14:54:50 HCPWRP961W SYSTEM SHUTDOWN COMPLETE
00: HCPGIR450W CP entered; disabled wait PSW 00020000 00000000 00000000
00000FFF

```

---

### 5.2.5 z/VM services

z/VM provides several services in the form of virtual machines. A virtual machine is similar to a z/OS Started Task, TSO User, or batch job. Unlike some operating systems, CP does not have the concept of a *process*. Instead, all CP knows is how to run virtual machines. This means that any extra service function not built directly into CP must be implemented as a service virtual machine.

A *service virtual machine* is the same as any other virtual machine, except it runs certain software (typically on top of CMS) that provides a service to some or all of the other users on the system.

The following examples are services provided by service virtual machines:

- ▶ TCP/IP networking stack
- ▶ User directory maintenance (Dirmaint)
- ▶ Security manager (RACF)
- ▶ Performance data collection and reporting (Performance Toolkit)
- ▶ Systems management service (SMAPI)

Service virtual machines in z/VM usually have a user name that corresponds with the service it provides. Table 5-1 lists several common service virtual machines and brief descriptions of the service provided.

*Table 5-1 Common service virtual machines*

<b>Guest name</b>	<b>Service provided</b>
TCPIP	TCP/IP networking stack and tools like FTP and Telnet
DIRMAINT	User directory maintenance
DATAMOVE	Disk copying and formatting services for DIRMAINT
PERSFVM	Performance recording and reporting
RACFVM	Security management for guests, devices and services
VSMERVE	Systems management service
RSCS	Remote spool device capability
PVM	Remote communication and system access
EREP	Error recording
DISKACNT	User accounting recording
OPERSYMP	Symptom recording
VMSEVR VMSERVS VMSERVU	Support for Shared File System (SFS)

## 5.3 Managing a guest operating system virtual machine

Guest support in z/VM allows you to run multiple images of production operating systems. You can use guest support in z/VM to develop, test, manage and migrate operating systems that run on System z alongside your production systems. The following sections discuss guest systems supported and how to operate the virtual machines.



### 5.3.1 Guest support

All of the supported mainframe operating systems can run under z/VM, including z/VM itself. For a list of supported mainframe operating systems, the type of support z/VM offers, and other useful information, refer to notes in *z/VM: General Information*, GC24-6095. If running on an IFL, then only z/VM and Linux are allowed.

**Tip:** *z/VM General Information*, GC24-6095, also has a list all of supported hardware that can be used with any release of z/VM.

The concept of having each user be a virtual machine is new to z/OS users. Therefore, the next sections explain how to manage them (start, pause, resume, and halt).

### 5.3.2 Starting a guest operating system

Each guest operating system is run from individual z/VM virtual machine user IDs. Logging on to these user IDs is done in the same manner as any other z/VM user ID, and usually comes up running in a CMS environment. From the log on session, a guest operating system can be loaded on that virtual machine's storage and run much the same as though it were running in an LPAR.

In z/VM, starting an operating system this way is still like using IPL (initial program load). When you IPL an operating system, it takes control of the virtual machine's storage; any other operating system that was running before is cleared from memory and no longer controls the virtual machine. Keep in mind that CP will still be running, because CP is not a guest operating system.

In CP, you perform an IPL by using the IPL command. CP can IPL directly from a device, in which case the operating system is read from the data residing on the device. Or CP can IPL from data stored in shared memory known as a *Named Saved System* (NSS). To IPL from a device, give the virtual device number of the device you want to IPL; see Example 5-21.

*Example 5-21 IPL of the 190 disk*

---

```
IPL 190
z/VM V5.3.0    2007-05-02 16:25
Ready; T=0.01/0.01 09:37:40
```

---

In Example 5-21 we IPLed, the 190 disk, which by default contains the CMS operating system. At this point CMS is running and any command issued is processed by CMS first.

An NSS is a copy of an operating system's kernel or nucleus, which has been saved in shared CP storage. Using an NSS to IPL an operating system has several advantages over using disks:

- ▶ Only one copy of the operating system will exist in memory no matter how many guests have IPLed it. This can lead to tremendous storage savings if you have numerous guests.
- ▶ Only one copy of the operating system exists, therefore, updating everyone who uses it to a newer version is as simple as replacing that single NSS.

To IPL from an NSS, provide the name of the saved system; see Example 5-22. Most z/VM installations have a CMS NSS set up.

*Example 5-22 IPL of the CMS named saved system*

---

```
IPL CMS
z/VM V5.3.0    2007-05-02 16:25
Ready; T=0.01/0.01 09:37:40
```

---

Example 5-22 shows we IPLed CMS with the CMS NSS instead of the CMS disk. Notice that CMS starts exactly the same way that it did when we IPLed the 190 disk.

**Note:** Certain guest operating systems require that you perform a SYSTEM CLEAR command to clear out the guest's virtual memory before IPLing the guest. You may, alternatively, tell the IPL command to clear the memory for you by specifying the CLEAR parameter:

```
IPL 190 CLEAR
```

### 5.3.3 Issuing CP commands while running a guest operating system

After a guest operating system is started, all commands entered at the terminal will typically be processed by that operating system and not by CP. Sometimes, however, you might have to interact with CP for various reasons, such as linking to a new disk, finding out how many other users are on the system, changing your virtual networking hardware, or any other CP-related task.

CP provides a way for you to issue commands that bypass the guest operating system and go directly to CP. We use the #CP command for this purpose. You issue the command #CP followed by whatever CP command you want to execute.

For example, assume you start your guest operating system, which detects only one CPU, but you think that your virtual machine has three CPUs. Example 5-23

on page 251 shows how you can verify that your virtual machine does indeed have three CPUs.

*Example 5-23 Issuing a command to CP from within a guest operating system*

---

```
#CP QUERY VIRTUAL CPUS
CPU 00 ID FF02991E20948000 (BASE) CP   CPUAFF ON
CPU 01 ID FF02991E20948000 STOPPED CP   CPUAFF ON
CPU 02 ID FF02991E20948000 STOPPED CP   CPUAFF ON
```

---

When you issue a **#CP** command, CP temporarily suspends your guest operating system long enough to complete your command, and then it resumes it. To your guest operating system, this is transparent. This process is generally very fast and seamless.

**Notes:**

- ▶ This method of interacting with CP from within your guest operating system works flawlessly for most guest operating systems. However, it fails when you are running z/VM in a z/VM guest. In this case, you have to pause the z/VM that is running as your guest operating system before you can issue commands directly to the underlying CP. Refer to 5.3.4, “Pausing a guest operating system” on page 251, for more information about this topic.
- ▶ CMS assumes that any commands you issue, and that it does not recognize, are CP commands and it will pass them directly to CP for you. This means you do not have to use the **#CP** command to force CP to execute commands when you are in CMS. You can simply execute the CP command normally and CMS will pass the command to CP for you.

### 5.3.4 Pausing a guest operating system

CP also has a command for pausing your guest operating system temporarily. You might want to do this if you have to issue numerous CP commands but you do not want the guest operating system running or interfering with your work.

You might also want to do this if you are a programmer who is debugging a guest operating system. To stop the guest operating system and return control to CP, enter the following command:

```
#CP STOP
```

Although this command produces no output, the end result is that the guest operating system is stopped and you can then interact directly with CP until you specifically resume running the guest operating system.

This method of pausing your guest operating system works flawlessly for almost all guest operating systems. However, it fails when you are running z/VM in a z/VM guest. When you are running z/VM in a z/VM guest, you essentially have CP running as your guest operating system. Therefore, you have *two* instances of CP to deal with:

- ▶ The first level CP is the instance of CP that started when you logged on to the system and your virtual machine was created.
- ▶ The second level CP was created when you IPLed it from within your first level CP instance.

When you are running a second level CP, the `#CP` command issues commands to your second level CP—and *not* to your first-level CP, as you might expect.

Figure 5-3 shows the scenario when you have a second-level z/VM system.

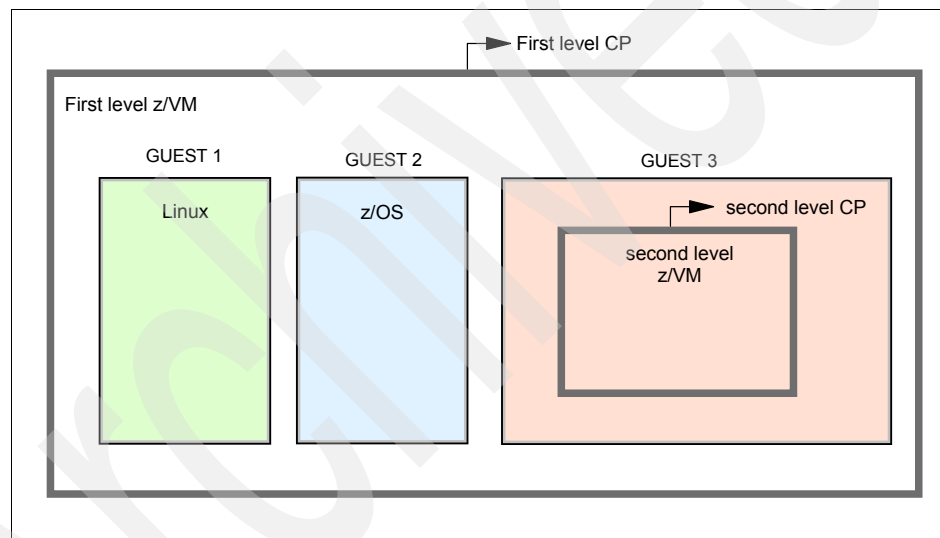

Figure 5-3 First-level and second-level CPs.

To drop out of your second-level CP and issue commands directly to your first-level CP, press the PA1 key on the 3270 terminal keyboard. When you use the PA1 key (known as the Program Attention 1 key), the second-level CP (including any guest operating system it is running) is paused and your next command will be executed by your first-level CP.

**Note:** When you press the PA1 key to pause a guest operating system, you might find that it only remains paused while you execute one command. After this, it will resume again automatically. If this happens, it is because the RUN parameter is turned on for your first-level virtual machine. The RUN parameter controls this behavior.

To turn off the RUN parameter after you have pressed the PA1 key and your first-level CP is in control, execute the following command:

```
SET RUN OFF
```

From this point, you will be able to execute as many first-level CP commands as you want and the second-level CP will not resume until you tell it to.

You may also issue the SET RUN ON command to turn the RUN parameter on if you wish. Having RUN set to ON will ensure that your guest operating system remains running when you disconnect from the guest.

### 5.3.5 Resuming a guest operating system

To resume your guest operating system (no matter what guest operating system you are running) use the BEGIN command. The BEGIN command takes no parameters and produces no output of its own (Example 5-24), although you might see output from your guest operating system as it continues to execute.

*Example 5-24 Restarting a stopped guest operating system*

---

```
BEGIN
```

---

**Note:** In some cases, you might be required to clear your 3270 terminal window before your guest operating system can resume operation.

### 5.3.6 Halting a guest operating system

When you are finished with a guest operating system, use whatever command or procedure that operating system has for a proper shutdown, because not doing so can lead to data loss.

CP does, however, provide a command to halt the running guest operating system, clear the systems storage, and return directly to CP; see Example 5-25 on page 254.

SYSTEM CLEAR

---

You might want to halt your guest operating system in this way if it has crashed or is stopped and is unresponsive to commands.

**Note:** Because you will be running a guest operating system, you might have to precede the SYSTEM CLEAR command with #CP, as discussed previously.

### 5.3.7 Managing CPUs

Processors are known as *CPUs* when they are virtual because CP reserves the term *processor* for real processors. A CPU is not actually a device because it does not have a virtual device number like all other devices do. Nevertheless, you can think of CPUs as devices because we manage them in a similar fashion.

Each virtual CPU has a *CPU address* which is like a virtual device number, but does not conflict with the virtual device number space. The virtual CPU address space is always represented in hexadecimal and ranges from *00* to *3F*.

You can define up to 64 virtual CPUs per virtual machine. Also note that you can have a larger number of virtual CPUs defined than the system has real processors. Virtual CPUs are scheduled to run on real processors when real processor time is available.

Having more CPUs than processors is like running more programs than you have processors on your desktop workstation. CP handles this intricate scheduling of resources much like your desktop operating system handles scheduling for your programs and their processes.

**z/OS analogy:** Managing logical CPUs in z/OS is done through the following commands:

```
CF CPU(n)
ONLINE
CF CPU(n),OFFLINE
```

#### Querying CPUs

Your virtual machine must have at least *one* CPU, but it can have more. You can obtain information about the CPUs on your virtual machine by using the Query VIRTUAL CPUS command, shown in Example 5-26 on page 255. (Do not confuse this command with the **Query CPU** command, which displays the virtual CPU ID).

*Example 5-26 Output from the QUERY VIRTUAL CPUS command*

---

**QUERY VIRTUAL CPUS**

CPU 00 ID FF02991E20948000 (BASE) CP CPUAFF ON

---

This output contains one line per CPU, which can be interpreted as follows:

- ▶ The virtual machine has one CPU, and that CPU address is 00.
- ▶ The ID of the CPU address is *FF02991E20948000*.
- ▶ Encoded in the CPU ID is information about the hardware and the environment on which your virtual machine is running. The details are not critically important and thus not covered here.
- ▶ Setting CPUAFF to ON means that CPU affinity is on for this CPU. *CPU affinity* refers to how having different types of processors and CPUs is handled on your system; this is a complex subject and is beyond the scope of this book.
- ▶ The (BASE) denotes the *base CPU*. This means that this CPU was the first one created when you logged on to your virtual machine. This CPU is required by your virtual machine and cannot be detached or redefined. All other CPUs can be detached and redefined.

## Defining CPUs

If you have the appropriate privileges, you can define more CPUs for your virtual machine. The ability to define more CPUs is defined in your virtual machine's directory entry; this is controlled by the system administrator.

If you are allowed to have more than one CPU defined, the limit is from 2 to 64. To define a new CPU, use the DEFINE CPU command; see Example 5-27.

*Example 5-27 Defining a single virtual CPU*

---

**DEFINE CPU 1**

CPU 01 defined

---

The DEFINE CPU command takes an argument that is either the CPU address you want the new CPU to have, or a dash-separated range of addresses if you want to define more than one CPU; see Example 5-28.

*Example 5-28 Defining multiple virtual CPUs*

---

**DEFINE CPU 1-3**

CPU 01 defined

CPU 02 defined

CPU 03 defined

---

**Note:** CP does not provide a command for checking the maximum number of CPUs you are allowed to define. You determine this by either trial and error, or by checking your user directory entry for the value in the MACHi ne statement.

### Detaching CPUs

If you decide that you do not need a virtual CPU that is already defined, then you can remove it by using the DETACH CPU command (abbreviated **DET CPU**). It takes the same argument format as DEFINE CPU, which means you can detach a single CPU or a range of them with a single command; see Example 5-29.

*Example 5-29 Detaching a CPU with the DETACH command*

---

```
DETACH CPU 1  
CPU 01 detached
```

---

**Note:** Use this command carefully. Detaching a CPU causes your virtual machine to be reset and any running operating systems will be halted immediately.

## 5.3.8 Managing storage (main memory)

Every virtual machine has memory. How much storage any particular virtual machine is allowed to have is determined by the system administrator and is defined in the user directory. *Storage* is not really a device, because it does not have a device number as all other devices do. Managing storage is simple because there is very little you need to know about it.

Your virtual machine's memory is virtual, just as with all of its other resources. Because it is virtual, it can exist anywhere in physical memory, or even on a disk (backing physical memory with disk-based storage is commonly referred to as *paging* or *swapping*).

As with CPUs, CP allows you to overcommit real storage. When a guest is not logged on, it is not consuming any memory at all. Only when a guest logs on does CP allocate memory for it and its virtual CPUs, and create devices.

But even when a guest with 1 GB of storage logs on, it is not immediately using all 1 GB of its memory. If it is not running an operating system, then it is using an extremely small portion of its memory. CP allocates physical memory only to back a guest's virtual memory when that guest actually uses the memory.



**z/OS analogy:** In z/OS, managing storage is similar to specifying the *REGION* for users, batch jobs, or STCs.

## How much memory does your VM have?

Determining how much memory your virtual machine (VM) has is easy if you use CP's QUERY VIRTUAL STORAGE command; see Example 5-30.

*Example 5-30 Output from the QUERY VIRTUAL STORAGE command*

---

### QUERY VIRTUAL STORAGE

STORAGE = 32M

---

In the example, the virtual machine has access to 32 MB of storage. If it requires more storage than is initially provided for it by CP, you might have the capability to increase the storage allotment.

When an administrator sets up a directory entry for a virtual machine, the administrator specifies two values for that particular virtual machine's storage. The first value is the initial amount of storage that virtual machine is given at logon time, and the second value is the maximum amount of storage that virtual machine is allowed to use.

## Changing the VM storage size

You can increase or decrease the amount of storage of your virtual machine by using the DEFINE STORAGE command and a single argument, which is the amount of storage that you would like your virtual machine to have.

The argument has two parts: a number and unit of measure. Valid units of measure are listed in Table 5-2.

*Table 5-2 Valid units of storage measurement*

Abbreviation	Amount of memory
K	Kilobytes
M	Megabytes
G	Gigabytes
T	Terabytes

Use this command carefully because it causes a system reset, which means it *clears* all of the virtual machine's memory and *stops* any running guest operating systems.

This is not an issue however, if you are simply running CP and not running a guest operating system. In Example 5-31, we redefine our virtual machine to have 4 MB of storage.

*Example 5-31 Setting the virtual machine's storage size to 4 megabytes*

---

```
DEFINE STORAGE 4M  
STORAGE = 4M  
Storage cleared - system reset.
```

---

As shown in Example 5-32, we revert to our original size.

*Example 5-32 Setting the virtual machine's storage size to 32 megabytes*

---

```
DEFINE STORAGE 32M  
STORAGE = 32M  
Storage cleared - system reset.
```

---

#### **Notes:**

- ▶ Your storage requirements can vary, depending on what you are doing with your virtual machine. However, the machine probably does not require as much storage you might initially think. With a typical desktop computer we tend to estimate memory needs very high as memory grows increasingly cheaper and a high estimate imposes no performance penalty to the system. With z/VM, it is important to understand your guest operating system, the workloads that will be run on it, and their memory consumption characteristics.
- ▶ CP does not provide a command for checking the maximum storage size you are allowed to define. You can, however, determine this by simply attempting to define a storage size of 99 Terabytes (**DEFINE STORAGE 99T**) which will more than likely be far more than you are allowed to define. In this case, the resulting error message will tell you your maximum storage size.

### **5.3.9 Managing DASD**

A Direct Access Storage Device (DASD) is a simple magnetic disk that you access to store data much the same as it is used in z/OS. The z/VM disks are allocated on portions of DASD volumes and contains files important to guest operating system.

## Terminology

Before discussing DASD, you should understand the associated terminology and how z/VM manages it.

The mainframe that your z/VM instance is running on is connected to a type of physical disk that we refer to as *real DASD*. This DASD is segmented into units called DASD packs (also referred to as *volumes*). z/VM general users do not have the capability to examine the real DASD packs on the system.

**Note:** Real DASD packs are of varying sizes. The names and sizes for the most widely used are as follows:

- ▶ 3390-3 (also known as mod 3) 3339 cylinders are roughly 3 GB.
- ▶ 3390-9 (also known as mod 9) 10017 cylinders are roughly 9 GB.
- ▶ 3390-27 (also known as mod 27) 30051 cylinders are roughly 27 GB.

The system administrator can dedicate a DASD pack to a guest. This means that access to the entire pack is given directly to that guest. This is known as a *dedicated DASD pack*.

A real DASD pack can contain many smaller virtual DASD packs (much as modern hard disks can be partitioned into many partitions that each appear to be a single disk). One of these smaller partitions is called a *minidisk*. Any number of minidisks can be created from a DASD pack, and each one can be arbitrarily assigned to a different guest. A guest can have many minidisks.

**z/OS hint:** z/VM minidisks are similar to the z/OS PDS where the members can have different DCBs.

A guest uses a minidisk and a dedicated DASD device in exactly the same ways. In both cases, the guest sees a virtual DASD device. A virtual DASD device is sometimes just referred to as a *disk*.

The three types of DASDs that we discuss are:

- ▶ Real DASD resides on a real physical disk, and is used to create minidisks.
- ▶ TDISK-based DASD resides on real DASD, but is only temporary and is destroyed when you log off.
- ▶ VDISK-based DASD resides in storage and is destroyed when you log off.

For an in-depth discussion on other DASD operations, consult the *z/VM: System Operation guide*<sup>6</sup>.

<sup>6</sup> <http://publibz.boulder.ibm.com/epubs/pdf/hcsf2b20.pdf>

## Examining your DASD

To obtain a list of all of the virtual DASD devices that are available to you, use the QUERY VIRTUAL DASD command; see Example 5-33.

*Example 5-33 Output from the QUERY VIRTUAL DASD command*

---

### QUERY VIRTUAL DASD

```
DASD 0190 3390 LX6RES R/O 107 CYL ON DASD CD31 SUBCHANNEL = 0005
DASD 0191 3390 DKCD37 R/W 005 CYL ON DASD CD37 SUBCHANNEL = 0000
DASD 019D 3390 LX6W01 R/O 146 CYL ON DASD CD32 SUBCHANNEL = 0006
DASD 019E 3390 LX6W01 R/O 250 CYL ON DASD CD32 SUBCHANNEL = 0007
DASD 0401 3390 LX6W01 R/O 146 CYL ON DASD CD32 SUBCHANNEL = 0009
DASD 0402 3390 LX6W01 R/O 146 CYL ON DASD CD32 SUBCHANNEL = 0008
DASD 0405 3390 LX6W01 R/O 156 CYL ON DASD CD32 SUBCHANNEL = 000A
```

---

The example displays several different DASD devices available to us. The output shows one DASD device per line. In the first DASD line, the fields have the following meanings:

0190	The virtual device number of this DASD device.
3390	The type of actual DASD hardware in use.
LX6RES	The volume label of the real DASD pack label in which this virtual DASD device lives.
R/O	The level of access you have to the device.
107 CYL	The size of this DASD device (107) as shown in cylinders (CYL).
ON DASD CD31	The real address of the DASD pack that this virtual DASD device resides.
SUBCHANNEL = 0005	The subchannel number for our virtual device. A discussion of subchannels is beyond the scope of this book.

The following sections explain the most significant parameters in more detail.

### **Virtual device number**

As previously mentioned, the virtual device number uniquely identifies this device to your virtual machine. This can be any hexadecimal number that is not already defined to your virtual machine.

### **Type**

The type used to be important many years ago when there were multiple types of real DASDs. Today, except for the oldest installations, you probably will not see any type of DASD other than 3390. The type parameter is kept in place to

maintain backward compatibility. One exception is when you are dealing with VDISK (see “Virtual DASD (VDISK)” on page 264 for more information about this topic).

### ***Volume label and real device address***

The volume label and the real device address both apply to the real DASD pack that houses this particular virtual DASD device. These parameters are provided for informational purposes and you are not likely to need to refer to them unless you are a system administrator.

### ***Size in cylinders***

The size of DASD devices is given in cylinders. For 3390 DASD, a single cylinder is exactly equivalent to 849,960 bytes, which in turn is roughly equivalent to 850 KB.

#### **Notes:**

- ▶ To determine how many megabytes your x cylinder DASD device holds, multiply x by 0.85.
- ▶ To determine how many cylinders you should have for x MB of data, multiply x by 1.2.

## **Creating DASD**

At some time, you might require more disk space. However, the definition of a new DASD pack must be performed by an administrator, because a new virtual DASD device must be backed by a real disk somewhere, and general users do not have the authority to allocate from real disks.

You might, however, have the authority to create a TDISK or a VDISK; refer to “Temporary DASD (TDISK)” on page 262 and “Virtual DASD (VDISK)” on page 264 for details about these topics. Another option might be to ask your administrator for shared file pool (SFS) space; refer to 5.3.11, “The CMS Shared File System” on page 272 for further details.

## **Accessing another user’s DASD**

This book described the concepts of accessing someone else’s disks (“Accessing another user’s disk (linking)” on page 130). With the proper authority you can read from and execute programs, or even write to the other disk. Refer to that section for detailed information about the subject.

## **Removing DASD**

You can remove a DASD device in the same way you would remove any other virtual device, by using the DETACH command. As its only parameter, this

command takes the virtual device number of the device to detach. See Example 5-34.

*Example 5-34 Example of the DETACH command*

---

**DETACH 592**  
DASD 0592 DETACHED

---

Do not be concerned that you will lose anyone else's data by detaching a disk that you linked. When you detach a disk, all you are doing is removing the virtual device within *your* virtual machine that points to the real disk. (This is not true, however, for TDISKS and VDisks.)

### **Temporary DASD (TDISK)**

A TDISK is a virtual DASD device that is allocated from a pool of real DASD packs set aside specifically for the creation of temporary disks. TDISK is an abbreviation of temporary disk.

#### **Important:**

- ▶ When you log off or the system fails, any TDISKs that you have created are destroyed and the data is lost. A TDISK is meant to be used as temporary storage space.
- ▶ Do not store the only copy of important data on a TDISK.

TDISKs cannot be linked by other user IDs.

**z/OS hint:** A temporary z/VM DASD is similar to z/OS temporary data sets, for instance by specifying:

```
DSN=&&DATASET,DISP=(NEW,DELETE) . . . .)
```

### ***Creating a TDisk***

Not all z/VM installations allow the creation of TDISKs. This might be the case for your installation if the system administrator has not set up the system for TDISK allocation, or if all TDISK space is in use at the time of your request.

However, you can request a TDISK allocation by using the DEFINE T3390 command. The T3390 argument specifies that you want to create a temporary model 3390 DASD device.

Note that DEFINE T3390 command takes two parameters: the virtual device number you want to assign to the new disk, and the size of this disk in cylinders.

If you want a TDISK at device number *9FF* that is 100 cylinders in size, use the command shown in Example 5-35.

*Example 5-35 Defining a TDISK*

---

```
DEFINE T3390 9FF 100
DASD 09FF DEFINED
```

---

**Note:** If you want an x megabyte TDISK, multiply x by 1.2 to determine how many cylinders to specify during creation.

You can use the QUERY VIRTUAL DASD command to verify that your 9FF disk exists, as shown in Example 5-36.

*Example 5-36 Verifying that a TDISK was created*

---

```
QUERY VIRTUAL DASD
DASD 0190 3390 LX6RES R/O 107 CYL ON DASD CD31 SUBCHANNEL = 0005
DASD 0191 3390 DKCD37 R/W 005 CYL ON DASD CD37 SUBCHANNEL = 0000
DASD 019D 3390 LX6W01 R/O 146 CYL ON DASD CD32 SUBCHANNEL = 0006
DASD 019E 3390 LX6W01 R/O 250 CYL ON DASD CD32 SUBCHANNEL = 0007
DASD 0401 3390 LX6W01 R/O 146 CYL ON DASD CD32 SUBCHANNEL = 0009
DASD 0402 3390 LX6W01 R/O 146 CYL ON DASD CD32 SUBCHANNEL = 0008
DASD 0405 3390 LX6W01 R/O 156 CYL ON DASD CD32 SUBCHANNEL = 000A
DASD 0592 3390 LX6W01 R/O 070 CYL ON DASD CD32 SUBCHANNEL = 000B
DASD 09FF 3390 (TEMP) R/W 100 CYL ON DASD 59D4 SUBCHANNEL = 000C
```

---

Notice that there is no volume label for the TDISK, because it is residing in TDISK, and not on a specific real DASD pack.

To use this TDISK space to store temporary files, you must CMS-format the disk when you access it. We use the disk file mode of F for Example 5-37.

*Example 5-37 Format TDISK*

---

```
format 9ff f
DMSFOR603R FORMAT will erase all files on disk F(9FF). Do you wish to continue?
Enter 1 (YES) or 0 (NO).
1
DMSFOR605R Enter disk label:
tmp9ff
DMSFOR733I Formatting disk F
DMSFOR732I 100 cylinders formatted on F(9FF)
Ready; T=0.01/0.05 10:44:37
```

---

## Removing a TDISK

You remove a TDISK in the same way you would remove most other virtual devices, by using the DETACH command; see Example 5-38. As its only parameter, this command takes the virtual device number of the device to detach.

*Example 5-38 Removing a TDISK*

---

```
DETACH 9FF
DASD 09FF DETACHED
```

---

## Virtual DASD (VDISK)

A VDISK is a virtual DASD pack that resides in the z/VM system's main storage instead of on a real DASD. This is exactly like the concept of a RAM disk that you might be familiar with from other operating systems. Because they exist in storage, VDISKs tend to be significantly faster than normal DASD devices, and also significantly smaller because it takes main storage away from system use.

### Important:

- ▶ A VDISK exists exclusively in storage and is *not* backed by a real disk. This means that when you log off or the system fails, your VDISK is destroyed and the data is lost. A VDISK is meant to be a temporary storage space.
- ▶ Do not store the only copy of important data on a VDISK.

**z/OS hint:** VDISKs are similar to using VIO type unit definitions in z/OS.

## Creating a VDisk

Not all z/VM installations allow the creation of VDISKs. This might be the case for your installation if the system administrator has not set up the system for VDISK allocation, or if free memory is too scarce.

However, you can request a VDISK allocation by using the DEFINE VFB-512 command. VFB-512 is an acronym for Virtual Fixed Blocks of 512 bytes.

Note that the DEFINE VFB-512 command takes two parameters: the virtual device number you want to assign to the new disk, and the size of this disk in 512-byte blocks. So, if you want a VDISK at device number *8FF* that is 16 MB in size, use the command shown in Example 5-39 on page 265.



*Example 5-39 Creating a VDISK*

---

```
DEFINE VFB-512 8FF 31250
DASD 08FF DEFINED
```

---

**Note:** If you want an x megabyte VDISK, multiply x by 2000 to determine how many blocks to specify during creation.

You can use the QUERY VIRTUAL DASD command to verify that your 8FF disk exists, as shown in Example 5-40.

*Example 5-40 Verifying that a VDISK was created*

---

```
QUERY VIRTUAL DASD

DASD 0190 3390 LX6RES R/O 107 CYL ON DASD CD31 SUBCHANNEL = 0005
DASD 0191 3390 DKCD37 R/W 005 CYL ON DASD CD37 SUBCHANNEL = 0000
DASD 019D 3390 LX6W01 R/O 146 CYL ON DASD CD32 SUBCHANNEL = 0006
DASD 019E 3390 LX6W01 R/O 250 CYL ON DASD CD32 SUBCHANNEL = 0007
DASD 0401 3390 LX6W01 R/O 146 CYL ON DASD CD32 SUBCHANNEL = 0009
DASD 0402 3390 LX6W01 R/O 146 CYL ON DASD CD32 SUBCHANNEL = 0008
DASD 0405 3390 LX6W01 R/O 156 CYL ON DASD CD32 SUBCHANNEL = 000A
DASD 0592 3390 LX6W01 R/O 070 CYL ON DASD CD32 SUBCHANNEL = 000B
DASD 08FF 9336 (VDSK) R/W 31256 BLK ON DASD VDSK SUBCHANNEL = 000C
```

---

In this example, notice that the DASD type is 9336 for the VDISK, and not 3390 as it is for normal DASD. Also notice that there is no volume label or real DASD pack address listed for the VDISK, because it does not reside on a real disk, and the size is given in 512-byte blocks instead of cylinders.

You can see that the size of the disk that we received (31256 blocks) is slightly larger than the size we requested (31250). This is because VDISKS must be allocated in increments of 8 blocks. If you specify a size that is not an increment of 8, then CP automatically rounds up, so you get at least as much space as you asked for, and possibly more (but never less).

Another method of allocating VDISK space, for when a user ID logs on, is in the user directory (USER DIRECT). See Example 5-41. By adding the following statement in the MDISK area of a user's directory, VDISK space will be allocated each time the user logs on. Because this space is reallocated after each logon, any previous data destroyed.

*Example 5-41 V-DISK statement in USER DIRECT*

---

```
MDISK 9336 FB-512 V-DISK 31250 MR
```

---

**Notes:**

- ▶ Other users cannot link to your VDISK unless it is defined in the user directory.
- ▶ If a VDISK is defined in your directory and you log off, it will *not* be destroyed if another user has linked to it.

Each allocation of V-DISK space has to be CMS-formatted before files can be stored on the disk.

**Removing a VDISK**

You can remove a VDISK in the same way you would remove any other virtual device, by using the DETACH command. Its only parameter is the virtual device number of the device to detach; see Example 5-42.

*Example 5-42 Removing a VDISK.*

---

```
DETACH 8FF
DASD 08FF DETACHED
```

---

### 5.3.10 Spool devices

A *spool device* processes an ordered list of files or data kept in a queue. CP's spool devices are different from other I/O devices in that they are not associated with real devices, such as DASD.

You can have three spool devices, as listed in Table 5-3. Each exists primarily to work with spool files. The specifics of what spool devices and files are and how they work can be quite complex, but most of the details are not very important for the vast majority of users.

**Note:** This book presents an extremely simplified view of spool devices, because most users might never have to know all of the specifics. For more information about this topic, however, refer to *z/VM: Virtual Machine Operation*, SC24-6128.

*Table 5-3 Types of spool devices*

Spool device	Description
Reader	A virtual punch card reader
Punch	A virtual punch card punch

Spool device	Description
Printer	A virtual printer

For the purpose of our discussion, these devices are similar in nature. More specifically, the commands that we use for managing files within the spool device queues can be used on all of them in the same manner. In our examples, we concentrate on the reader device type.

**z/OS hint:** Spooling tasks in z/OS are performed within the Job Entry Subsystem (JES2 or JES3). Spool data is kept in JES2 HASPACE data set or in the JES3 equivalent.

### Uses for spool devices

In the early days of z/VM, most installations included real printers, punch card readers, and punches. Back then, these virtual devices were used to interface with the real hardware, so you could actually work with the real devices. Today, however, most installations do not have these real devices. However, spool devices are used for handling a virtual machine's input and output.

The reader is the virtual machine's input holding area and can be seen as a mail inbox. From that inbox, we can CP TRANSFER files to other uses or CMS RECEIVE the files onto a user's mdisk storage.

You may, by using the CMS command SENDFILE, send a file from one of your disks to other users. Those users are then free to save the file from their reader to one of their disks. The SENDFILE command actually uses your punch device to *punch* the file into the reader queue of the appropriate user.

The virtual card reader is also often used for booting other operating systems or stand-alone utilities, including Linux installer RAM files. When the file at the top of the reader queue is one that contains a loadable operating system or stand-alone utility, **IPL 000C** will begin the load process.

**Note:** CMS expects to find your reader at virtual device number *000C*, your punch at *000D*, and your printer at *000E*. For this reason, those devices are typically always created with the given device numbers.

### Querying a spool device

Querying a spool device gives you a great deal of information, and it can be done by using the QUERY command in a similar way to querying other virtual devices.

In Example 5-43, we query our reader, which is typically defined with the virtual device number 000C. (If your reader is not addressed as 000C, use the QUERY VIRTUAL ALL command to find your reader as discussed in “Your virtual machine's resources” on page 69.)

*Example 5-43 Querying a spool device*

---

```
QUERY VIRTUAL 000C
RDR 000C CL * NOCONT NOHOLD EOF READY
000C 2540 CLOSED NOKEEP NORESCAN SUBCHANNEL = 0002
```

---

Most parameters shown in the output deal with the spool device configuration or how your spool files are treated by the spool device.

### Creating a spool device

You create a spool device by using the DEFINE command. In most cases, your reader will have been defined for you. But if it has not been defined, provide an argument to the DEFINE command to define the type of device you are creating and the virtual device number, as shown in Example 5-44.

*Example 5-44 Defining a spool device*

---

```
DEFINE READER 000C

RDR 000C DEFINED
```

---

You can specify PUNCH and PRINTER in place of READER, to create those types of spool devices instead.

### Removing a spool device

You can remove a spool device by using the DETACH command, just like any other virtual device. Specify the virtual device number as an argument; see Example 5-45.

*Example 5-45 Removing a spool device*

---

```
DETACH 100
RDR 0100 DETACHED
```

---

This also works on punch and printer devices.

### Understanding spool files

Spool files can be seen as files that are queued up for further processing. They are either destined to a virtual machine (punch), awaiting a virtual machines

action (reader) or awaiting to be printed (print). None can be edited and only reader files can be read using the CP PEEK command.

**Note:** CP does not have editing capabilities. If you have to edit a file that is in CP spool, it must be transferred to the reader queue (if it were in the punch or print queue) and then received onto disk using the CMS **RECEIVE** command.

When your z/VM system was set up, your system administrator set aside some disk space for spool files. Any files that are in one of your virtual spool device queues actually exist on this disk space set aside as system spool space.

## Displaying files in your reader queue

CP allows you to display the information about the files in your reader queue. Use the QUERY READER ALL command, as shown in Example 5-46.

*Example 5-46 Output from the QUERY READER ALL command*

```
QUERY READER ALL
ORIGINID FILE CLASS RECORDS  CPY HOLD DATE TIME      NAME      TYPE
FRED    0008 A PUN 00000017 001 NONE 06/07 13:46:01 TUX1     NETLOG
FRED    0009 A PUN 00000008 001 NONE 06/07 13:49:44 PROFILE  EXEC
```

This example shows two files in the reader queue: a file named TUX1 NETLOG and a file named PROFILE EXEC. The significant points about the output are listed in Table 5-4.

*Table 5-4 Output from QUERY READER ALL command*

Column	Description
ORIGINID	The user name of the virtual machine that sent the file to your reader queue
FILE	The unique number assigned to the file. We will use this with other commands.
DATE & TIME	The date and time that this file was placed in the reader queue
NAME & TYPE	The file name and type given to this file by the creator

You can query the files in your printer and punch queues by substituting PRINTER or PUNCH for READER in the QUERY command shown in Example 5-46.

## Adding files to your reader

Files are added to your virtual reader when another user sends a file to you or if a program is set up to create output that is destined for your user ID.

If you want to have a CMS file added to your reader, you could simply use the SENDFILE command to send that file to your user ID. If you want to have a file in your print or punch queue added to your reader, you could do a transfer of the file, as shown in Example 5-47.

*Example 5-47 Transfer a file from your print queue to your reader*

---

**q prt all**

```
OWNERID FILE CLASS RECORDS CPY HOLD DATE TIME NAME TYPE DIST
LNKGUI 0029 T CON 00000017 001 NONE 06/09 11:51:06 LNKGUI
Ready; T=0.01/0.01 10:20:26
```

**trans prt 29 \* rdr**

```
RDR FILE 0029 SENT FROM USER1 PRT WAS 0029 RECS 0017 CPY 001 T NOHOLD NOKEEP
0000001 FILE TRANSFERRED
Ready; T=0.01/0.01 10:21:26
```

**q rdr all**

```
ORIGINID FILE CLASS RECORDS CPY HOLD DATE TIME NAME TYPE DIST
LNKGUI 0029 T CON 00000017 001 NONE 06/09 11:51:06 LNKGUI
Ready; T=0.01/0.01 10:22:26
```

---

## Deleting files in your reader

You can remove a file from your reader queue by using the PURGE command. With this command, you can specify to clear a single file, multiple files, or all of the files in your reader queue. To clear a single file, specify which queue to delete from and the number of the file within that queue to delete; see Example 5-48.

*Example 5-48 Deleting a single file from your reader*

---

**PURGE READER 8**

```
0000001 FILE PURGED
```

---

CP responds that it deleted one file. If you want to delete multiple files, specify all of the file numbers for the files you want to delete, separated by spaces; see Example 5-49.

*Example 5-49 Deleting multiple files from your reader*

---

**PURGE READER 8 9 10**

```
0000003 FILES PURGED
```

---

CP now responds that it has deleted all three of the files specified. To delete all of the files in your reader queue, specify the ALL parameter, as shown in Example 5-50 on page 271.

*Example 5-50 Deleting all files from your reader*

---

```
PURGE READER ALL  
0000004 FILES PURGED
```

---

You can delete the files in your printer and punch queues by substituting `PRINTER` or `PUNCH` for `READER` in the `PURGE` command shown in Example 5-50.

### **Moving a file in your reader to someone else's reader**

The `SENDFILE` command (in CMS) provides a useful way to move a file from one of your disks to someone else's reader queue. If, instead, you want to send a file from your reader queue to someone else's reader queue, use the `CP TRANSFER` command:

```
TRANSFER yourID READER fileNumber destID READER
```

Table 5-5 lists the `TRANSFER` command parameters.

*Table 5-5 TRANSFER commands parameters*

Parameter	Description
yourID	Your user ID. If you are a system administrator, you probably have permission to transfer files from anyone's reader queue by specifying their guest name here.
fileNumber	The number of the file in your reader queue you want to send.
destID	The user ID of the person that you want to receive the file you are sending.

In Example 5-51, we transfer file number 13 from user `TUX1` to user `FRED`.

*Example 5-51 Moving a file from TUX1's reader queue to FRED's reader queue*

---

```
TRANSFER TUX1 READER 13 FRED READER  
RDR FILE 0013 SENT TO FRED RDR AS 0025 RECS 0008 CPY 001 A NOHOLD  
NOKEEP
```

---

The output shown in Example 5-51 states that the file was sent to `FRED`, as we have requested. If someone is logged on to `FRED`'s console, that user will see a similar message: an alert that someone has sent a file.

The `TRANSFER` command also works with printer and punch devices. Simply substitute `PRINTER` or `PUNCH` for `READER` in the example.

### 5.3.11 The CMS Shared File System

z/OS programmers might be familiar with the z/OS UNIX System Services (z/OS UNIX or UNIX System Services), which allows z/OS to access UNIX files. The most noticeable difference between the z/OS UNIX file system and z/OS data sets is that z/OS UNIX is a hierarchical file system when accessed from within UNIX System Services.

The z/VM file system, CMS Shared File System (SFS), allows you to view the system in a hierarchical fashion: z/OS programmers might be more accustomed to this type of hierarchical file system.

SFS is an additional file system that is shipped with z/VM, and it offers several advantages over the normal CMS file system. Table 5-6 lists and compares these file systems.

Table 5-6 Compare and contrast SFS and normal CMS file system

Shared File System	CMS file system
Sharing at file level	Sharing at minidisk level
Minimum allocation: zero 4096 byte blocks	Minimum allocation: 1 cylinder
Hierarchical file system	Flat file system
Allocation can be changed dynamically	Bigger minidisk required
Recovery at file level	Recovery at minidisk level

SFS is essentially a collection of minidisk storage managed by a server. The following three main areas are shown in Figure 5-4 on page 273:

- Control data** Holds the definitions of the file pool and its users.
- Log data** Holds the logs so that, in the event of interruption, files can be rolled back.
- User data** Holds the user data. The server allocates data from here to give to users.



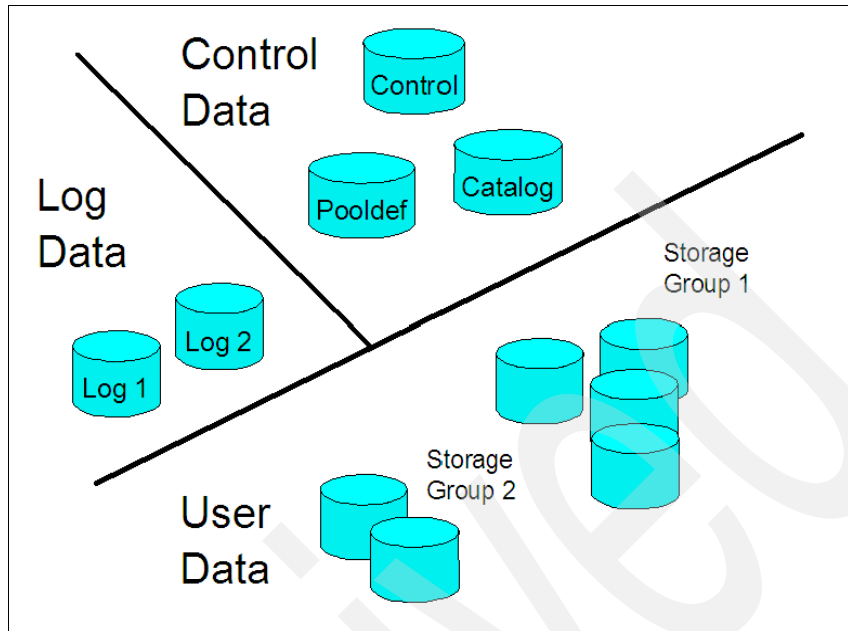

Figure 5-4 Shared File System (SFS)

With SFS, instead of a minidisk, you are enrolled in a file pool by an administrator and are given a number of 4096-byte blocks from a storage group that you use in a similar way to a CMS minidisk.

Although accessing the space is similar to accessing a CMS minidisk, you use the file pool name concatenated with your user ID instead of a minidisk device number. For example, instead of using 191 on and the ACCESS command, you would use:

```
VMSYSU:USERID
```

After accessing SFS, users can use commands to create directories and subdirectories in a similar way as they do on a workstation, creating a hierarchical file structure if needed. Users can then GRANT authority at the file level to allow other users to read or write to data in its file space.

If you have been allocated space in the file pool, review the commands listed in Table 5-7 on page 274.

Table 5-7 Commands related to SMS

Command	Description
SET FILEPOOL	Set (or reset) your default file pool; for example: set filepool vmsysu
QUERY FILEPOOL	Display your current file pool; for example: query filepool current
QUERY LIMITS	View how many 4-K blocks you have available to use; for example: query limits
DIRLIST	List you directories. This is similar to using FILELIST to list CMS files.
ACCESS	Assign a mode letter to your file space; for example: access vmsysu:cmsuser a ACCESS is similar to the way that minidisks are accessed.
CREATE	Create a directory; for example: create directory test1 CREATE is similar to <code>mkdir</code> on a PC.
GRANT	Grant other users access to files or directories.

The entire file system has an administrator who is responsible for backups and allocation of minidisks to storage groups as required.

z/VM is shipped with three file pool servers:

- ▶ VMSERVR is used by z/VM
- ▶ VMSERVS is used by z/VM
- ▶ VMSERVU, a sample user file system

For more information about these topics, refer to *z/VM: CMS File Pool Planning, Administration, and Operation*, SC24-6074, and *z/VM: CMS Commands and Utility Reference*, SC24-6073.

## 5.4 Job scheduling and running batch jobs

z/VM and Linux offer ways of scheduling jobs to run at a particular time of the day/month/year and also to make them run periodically. This is useful to schedule nondisruptive system maintenance tasks; to run these, you do not have to stop anything that any user might be doing at a given time. Tasks can include: compacting the system logs to save space, updating backups, and so on.

The task of scheduling batch jobs, however, is not a common concept in z/VM or Linux. In fact, to run many *batch* processes, you can either create a script for that or run all of them at once, knowing that they would eventually compete for I/O resources.

The following section gives an overview of tools similar to z/OS job entry subsystem (JES). You can simulate a batch processing queue by using those scheduling tools and creating scripts.

## 5.4.1 Job scheduling

This section compares job scheduling in z/VM and Linux.

### Job scheduling in z/VM

Scheduling a job is usually done with tasks that do not require human intervention, such as manipulating logs and creating backups. Scheduling a job in z/VM is not a usual task because administrators usually use available tools in guest systems to perform the tasks.

For the sake of completeness, the authors searched the Web and found products, such as *CA VM:Schedule for z/VM*, the IBM Operations Manager for z/VM, and two free tools (PROP and WAKEUP) shipped with z/VM, that accomplish job scheduling.

### Job scheduling in Linux

Linux systems have a utility tool called *cron* to schedule programs to run periodically. Scheduling information is placed in the `/etc/crontab` file, using the following format:

```
minute hour day month year username command
```

You can specify each time component as an integer number. For example, use the numbers 1 through 12 for the months of January through December. Or specify one or more components by using asterisk (\*) characters, which are treated as wildcards. For example, \* in the month component means the command will run at the specified day and time in every month. The username parameter should be the name of the user who executes the command, which might be different for security or authority reasons. For example, a backup process must be run by a user who can read all files in all directories. Each user may also put a crontab file in the home directory. For more information, refer to:

<http://www.linuxdoc.org>

You may also run either of the following commands, which provide more information:

```
man crontab
man 5 crontab
```

However, you do not have to use a text file; there is a simpler approach. Several directories exist in /etc where you can place a script file that automatically is executed at specific times:

- ▶ /etc/cron.hourly
- ▶ /etc/cron.daily
- ▶ /etc/cron.weekly
- ▶ /etc/cron.monthly

The script is then executed every hour, day, week, or month.

## 5.4.2 Running batch jobs

The term *batch job* originated in the days when punched cards contained the directions for a computer to follow when running one or more programs. Multiple card decks representing multiple jobs would often be stacked on top of one another in the hopper of a card reader, and be run in batches.

Today, jobs that run without any real-time dependencies or can be scheduled as resources permit, are called batch jobs. A program that reads a file and generates a report is considered to be a batch job.

z/OS uses a *job entry subsystem* (JES) to manage the flow of work in the system. In the next sections you are presented with tools and concepts to simulate what z/OS users can do with JES.

### Running batch jobs in z/VM: CMS Batch Facility

The *CMS batch facility* allows VM users to run their jobs in batch mode by sending jobs either from their virtual machines or through the real (system) card reader to a virtual machine dedicated to running batch jobs. The CMS batch facility then executes these jobs freeing user machines for other uses. If both the CMS batch facility and the Remote Spooling Communications Subsystem (RSCS) Networking Version 2 (or later version) are being executed under the same VM system, job input streams can be transmitted to the batch facility from remote stations by communication lines. Also, the output of the batch processing can be transmitted back to the remote station. The CMS batch facility virtual machine is generated and controlled on a user ID dedicated to execution of jobs

in batch mode. The system operator generates the *batch machine* by either of the following methods:

- ▶ Entering the BATCH parameter in the PARM field of the IPL command
- ▶ Specifying the NOSPROF parameter of the IPL command and entering the CMSBATCH command when the VM READ status appears.

After each job is executed, the batch facility IPLs itself, thereby providing a continuously processing batch machine. The batch processor IPLs itself by using the PARM option of the CP IPL command followed by a character string that CMS recognizes as peculiar to a batch virtual machine performing its IPL. Jobs are sent to the batch machine's virtual card reader from user terminals and executed sequentially. When no jobs are waiting for execution, the CMS batch facility remains in a wait-state, ready to execute a user job. The CMS batch facility is particularly useful for compute-bound jobs such as assemblies and compilations and for execution of large user programs, because interactive users can continue working at their terminals while their time-consuming jobs are run in another virtual machine. The system programmer controls the batch facility virtual machine environment by resetting the CMS batch facility machine's system limits, by writing routines that handle special installation input to the batch facility, and by writing exec procedures that make the CMS batch facility easier to use.

**Note:** For in-depth information about how to use the CMS Batch Facility, refer to the *CMS Planning and Administration*, SC24-6078 at:

<http://publibz.boulder.ibm.com/epubs/pdf/hcsg2b10.pdf>

## Simulating batch jobs in Linux

This section gives you a very simple overview of how to use scripts to simulate batch-like processing. You can also schedule *cron* to run the scripts during the night, for example, to run daily sales reports.

The scenario in this section makes use of *shell scripting*, a language interpreted by many Linux shells<sup>7</sup>, to control the batch behavior of the processes. This controlling script runs one program at a time. We wrote two simple programs to sort the words of text files: one in natural order and the other in reverse order.

The script is shown in Example 5-52 on page 278. It calls all programs found in the `./batch` folder, our sorting programs. Each of the programs has its corresponding input file in our the `./input` folder (where we placed the files for sorting) and each output is sent to our `./output` folder. The only constraint to

<sup>7</sup> A shell is a program that interprets user inputs, calls the corresponding system's commands, and displays the output of that command. It is the user interface shown in Linux consoles after you log in.

make our controlling script work is to name the input file the same name as the batch program, plus the suffix `-input`. Of course, you can write better scripts than this.

*Example 5-52*

---

```
#!/bin/bash

for i in `ls ./batch`; do
    echo "Starting batch program $i"
    ./batch/$i < ./input/${i}-input > ./output/${i}-output
done
```

---

The input file to feed our first program, the one that sorts it in natural order, is shown in Figure 5-5. The input for the second one is exactly the same, except that it says “this is unsorted file *two*” instead of *one*.



```
this
is
unsorted
file
one
d
g
t
e
w
a
i
o
p
```

*Figure 5-5 Text file used as input.*

Run the controller script as shown in Example 5-53, by calling the proper name of the script you created.

*Example 5-53*

---

```
ceron:~/scripts # ./controller.sh
Starting batch program 101_program
Starting batch program 102_program
ceron:~/scripts #
```

---

The outputs of our programs are our ./output folder, and are shown in Figure 5-6 on page 279 (natural order) and Figure 5-7 on page 279 (reverse order).

```
ceron:~/scripts/output # cat 101_program-output
cat 101_program-output
Results of processing input data file : Succesfull completion at Fri
May 23 11:50:13 EDT 2008

a an d e file g i is o one p t this unsorted w
ceron:~/scripts/output #
```

Figure 5-6 Output of the batch program to sort files in natural order

```
ceron:~/scripts/output # cat 102_program-output
Results of processing input data file : Succesfull completion at Fri
May 23 11:50:15 EDT 2008

w unsorted two this t p o is i g file e d an a
ceron:~/scripts/output #
```

Figure 5-7 Output of the batch program to sort files in reverse order

Notice that each program created its output based on its input and in accordance with its processing. Note, also, that the time stamps differ by two seconds. We had coded our programs to send to the output the current system time upon completion of the job, and made them sleep for a couple seconds before returning to simulate a high load process. These two seconds show that the processes were run one after another, as our controlling script did it its for loop.

By using scripts similar to these and scheduling them to run in cron you can simulate z/OS batch jobs. Go to the following Web site for references and links to shell scripting tutorials:

[http://en.wikipedia.org/wiki/Shell\\_script](http://en.wikipedia.org/wiki/Shell_script)

## 5.5 Cloning

As you can imagine, the process of repeatedly installing similar Linux images can quickly become tedious. For this reason, z/VM systems administrators need a simple, efficient, and repeatable process for creating these images on a z/VM system. Cloning a Linux image in z/VM takes only several minutes before a new image is up. This can be helpful to quickly bring up a test or development

environment or duplicate several production environments in minutes rather than days. Much literature is available about this subject.

Two resources for more information about cloning are:

- ▶ *z/VM and Linux on IBM System z: The Virtualization Cookbook for SLES 10*, SG24-7493.
- ▶ *z/VM: Getting Started with Linux on System z*, SC24-6096

## 5.6 Monitoring the system

System monitoring is one of the most important activities to administer a computer system. At some time, you will have to look at the system's resource usage to decide whether the system should be given more storage, DASD, or CPU. Alternatively, you can get the most out of your hardware if you can identify resource wastes in an LPAR, the virtual machine, or guest.

Tools exist in the z/VM and Linux worlds to allow you to accomplish these goals. Chapter 7, "Performance monitoring and system analysis" on page 319 gives a detailed overview on them.

## 5.7 Backing up data

As robust as a system might be, reasons exist why you should always back up the data regularly:

- ▶ Natural disasters, such as a fire
- ▶ Unexpected power outage that causes data corruption
- ▶ Hardware failure
- ▶ Program errors that destroys data

High-end systems, such as z/VM and Linux, cannot afford to lose data in a production system. Therefore, they have a variety of tools to help you back up your data. Chapter 8, "System events and logs, backup and recovery" on page 351 lists tools and commands available.

## 5.8 Maintaining the system

Systems must be maintained for several reasons:



- ▶ Security updates
- ▶ Software level upgrade
- ▶ Installation of new features

For those reasons, shutting down the production systems to perform maintenance is not desirable. In Chapter 9, “Applying system maintenance” on page 387 we talk about the ideal way to maintain a z/VM system and how it compares to z/OS.

## 5.9 Debugging the system

As much as a system administrator can be careful about his system by continuously monitoring and maintaining it, problems do arise. Knowing where to look for information to fix the problems, however, is what makes the difference between an ordinary and a good administrator. Chapter 8, “System events and logs, backup and recovery” on page 351 explains the tools available in z/VM and Linux that allow you to come to logical conclusions about a problem based on facts.

Archived

# System administration

This chapter introduces several new and powerful features in z/VM on System z to help you perform important administration tasks. You will learn about procedures and concepts related to System z security, user administration and privileges, and system networking.

## Objectives

After completing this chapter, you should be able to:

- ▶ Understand several of the tasks involved in managing z/VM and Linux on System z security
- ▶ Identify security related commands and statements
- ▶ Understand user classes
- ▶ Define users in z/VM

## 6.1 Managing z/VM security

When deploying virtualization technologies for server consolidation you must never overlook security issues. Such issues, if not addressed with proper attention, can expose companies to risk. Inevitably, new technologies are frequently the target of new security threats.

In this chapter, we explain how z/VM provides security to your virtualized instances and provide an overview on how to secure your systems.

Within z/VM, the term *security* is a reference to the authentication and authorization schemes for identifying users and controlling access to resources. System integrity, on the other hand, allows the z/VM Control Program (CP) to operate without interference or harm, intentional or not, from the guest virtual machines, and protecting the guest virtual machines from interfering with each other.

### 6.1.1 User authentication

User login to a z/VM system is achieved by starting a terminal session with z/VM (local or Telnet) and then providing a z/VM user ID and its associated password. Local terminal sessions are highly secure because the data does not travel over a network. Remote terminal (Telnet) or file transfer (FTP) sessions, which travel over internal or external IP networks, can be made highly secure by configuring and using the z/VM Secure Sockets Layer (SSL) support. The processing required for SSL is delivered through an SSL server supplied with z/VM, supporting 128-bit encryption and decryption services. The z/VM SSL server is a Linux for zSeries® application that must be installed separately. After the user has supplied the user ID and password, the Control Program validates the information. If the user ID and password are valid, the login is permitted and the terminal session is connected to the virtual machine's virtual console.

If you think of z/VM as a virtual computer room full of virtual servers, then think of a virtual machine user ID as a *virtual cage* around the server. No one can enter the cage unless they possess the key: the virtual machine password. This is very different from the discrete environment, where access to a machine room automatically gives access to all servers in that room.

Because the server console is protected by a z/VM password, you can more safely eliminate the protections normally given to a server's console. Automation techniques are greatly simplified if the automation tools do not have to, for example, enter the root password of a Linux server to shut it down or reboot it. Although at first glance this might seem to reduce system security, it actually

improves security by not requiring the root password to be known by the automation software.

A special capability available with z/VM is *Logon By*. This function enables the system administrator to define a shared virtual machine. When the user enters the shared user ID, the user also provides his or her own user ID and password. In this way, an audit trail is maintained of who is actually logged into a shared user ID, and the problems inherent in sharing passwords are avoided.

Remote access protocols such as rexec, ftp, and nfs, all require the client to authenticate using a z/VM user ID and password. At no time does z/VM trust the claims of an unauthenticated client. When authenticated, the remote client has the same access rights as the user would have if he or she were logged into the system with a terminal session.

For network applications, z/VM provides a Kerberos server and the programming interfaces that permit programs to take advantage of Kerberos authentication and encryption facilities. Note that the network application suite provided by IBM and the z/VM CP do not use Kerberos authentication. Although anonymous access to specific resources or to a virtual machine can be allowed by z/VM, such access must be explicitly enabled by the z/VM system administrator.

### 6.1.2 User authorization

When logged into the z/VM system, the virtual machine can access various types of resources within the z/VM system, including entire DASD volumes, minidisks, tape drives, network adapters, user files, system files, and so on. The security features of z/VM are designed so that a virtual machine can access only the resources specifically permitted to it.

Those permissions are given by the system administrator so that when the virtual machine is started, it automatically receives access to a certain resource, even if that virtual machine would otherwise be unable to access that resource. Alternatively, permissions are given dynamically by the system administrator or the owner of the resource.

Certain resources are accessible based on privilege class, others require additional authorization. The security facilities provided by z/VM can be enhanced according to any special or specific requirements for the customer's environment by the addition of an External Security Manager.

Although privileged commands can be used to change a running z/VM system, the system administrator might choose to set system configuration options during system initialization. This is accomplished by updates to the CP system

configuration file. Consequently, access to the system configuration file must be tightly controlled.

### 6.1.3 Intrusion detection

As an element of z/VM intrusion detection capabilities, if a logon is denied, the denial is tracked and a security journal entry is made when the number of denials exceeds an installation-defined maximum. When a second maximum is reached, logon to the user ID is disabled, an operator message is issued, and the terminal session is terminated.

Journaling is supported on z/VM. Virtual machine logons and linking to other virtual machine's minidisks are detected and recorded. Using the recorded information, you can identify attempts to log on to a virtual machine or to link to minidisks that use invalid passwords.

The TCP/IP component of z/VM detects and reports a variety of network intrusions, including SYN flooding, Smurf attacks and the Ping o' Death.

The z/VM Control Program (CP) defines and assigns virtual processors to the virtual machine. These virtual processors are matched to the physical or logical (if z/VM is running in a logical partition) processors available to the CP. If the operating system running in the virtual machine is capable of using multiple processors, it will dispatch its workload on its virtual processors as though it were running in a dedicated hardware environment. This capability can be extremely useful to test a guest operating system in a multiprocessor mode, even on a uniprocessor system.

### 6.1.4 Virtual processors security

The CP handles dispatching the virtual processors on the available real processors. A real processor can either be dedicated to a single virtual machine or shared among multiple virtual machines. Bear in mind that the CP handles only the processors it controls, so if z/VM is running in an LPAR, the logical processors might in fact be shared with other LPARs.

So, we have virtual machines dispatching their work on one or more virtual processors, which are mapped to one or more logical processors, which can be mapped yet again to one or more physical processors. Do not be concerned because there is no significant security risk if the virtual, logical, or physical processor configuration is changed, or if work is dispatched on different physical processors. The state of a processor is preserved for one virtual machine and restored for another by the z/VM Control Program just as PR/SM™ does for

LPARs. Therefore, no information can be passed from one virtual machine to another through residual data in processor registers.

## 6.1.5 z/VM privilege classes

z/VM is a system of privilege: a user can have either no privileges, or one or more privilege classes. Each privilege class represents a subset of CP commands that the system permits the user to run. Each privilege class, sometimes called CP privilege class, is defined for particular job or set of tasks, thereby creating an area outside of which the user cannot execute any commands. A user can be assigned to more than one CP privilege class. Users are unable to enter commands in privilege classes to which they are not assigned. This section has a summary of CP privilege classes, their associated users, tasks, and security implications

### Privilege class A

Privilege class A is the primary system operator. The system operator is among the most powerful and privileged of all z/VM users. The system operator is responsible for the system's availability and its resources. The system operator also controls accounting, broadcasts messages, and sets performance parameters.

### Privilege class B

Privilege class B is the system resource operator. The system resource operator controls the allocation and de-allocation of real resources, such as memory, printers, and DASD. Note that the system resource operator does not control any resource already controlled by the system operator or the spooling operator.

### Privilege class C

Privilege class C is the system programmer. The system programmer updates the functions of the z/VM system and can change real storage in the real machine.

### Privilege class D

Privilege class D is the spooling operator. The spooling operator controls spool files and real unit record devices, such as punches, readers, and printers.

### Privilege class E

Privilege class E is the system analyst. The system analyst has access to real storage and examines dumps to make sure that the system is performing as efficiently and correctly as possible.

## Privilege class F

Privilege class F is the IBM service representative. The representative of IBM who diagnoses and solves problems by examining and accessing real input and output devices and the data they handle.

## Privilege class G

Privilege class G is the general user. This is the most prevalent and innocuous of the CP privilege classes. The commands that privilege class G users can enter affect only their own virtual machines.

## Privilege class ANY

The commands in this privilege class are available to any user.

## Examples of privilege classes

Privilege classes A, B, C, D, E, and F require individuals worthy of significant trust and whose activities require careful auditing. For example, users with privilege class B or C can modify a system's CP privilege. Because this modification violates the Controlled Access Protection Profile (CAPP) security policy, system programmers and similarly privileged users must be trusted to not tamper with the system of CP privilege (and auditing must confirm this trust).

**Note:** Red Hat Enterprise Linux 5 is the first Linux operating system to ship with native support for the functions necessary to meet Common Criteria for Trusted Operating Systems. This includes all functionality to enable EAL 4+ certification under the following protection profiles: Controlled Access Protection Profile (CAPP), Role Based Access Control (RBAC), and Labeled Security Protection Profile (LSPP).

For more information, see *IBM: Security Benefits of Red Hat Enterprise Linux 5 on IBM System z*, available at:

[http://www.redhat.com/f/pdf/rhel/security\\_rhel5.pdf](http://www.redhat.com/f/pdf/rhel/security_rhel5.pdf)

As another example, privilege class C users can enter the **cp store host** command that allows them to alter real storage. It also enables users to negate the CAPP classification.

Privilege class G users have no influence outside their own virtual machines. So, with the exception of access to storage objects, they have very little security relevance.

The ANY privilege class commands cannot violate the security policies of the system. This is because all commands in the ANY privilege class are auditable and subject to either Discretionary Access Control (DAC) or Mandatory Access



Control (MAC). Therefore, class ANY users, together with class G users, cannot violate the security policy. In the Control Program, each level of privilege is discrete and not predicated on others. Furthermore, each privilege class (a subset of commands) is related to one or more function types (subsets of users).

### 6.1.6 System user IDs involved in security

Certain user IDs are defined as part of the installation process. The standard user IDs for the default system installation are:

- ▶ OPERATOR: System operator and high privilege user ID is similar to root in Linux systems.
- ▶ MAINT: System administration and maintenance is similar to OPERATOR from an authorization point of view.
- ▶ EREP: Environmental Record Editing and Printing Program (EREP) is a hardware anomaly detection and predictive failure system.
- ▶ DISKACNT: Records events such as logon and logoff.
- ▶ OPERSYMP: System dump analyzer and problem tracking system. Retrieves symptom records.

### 6.1.7 Security relevant statements

The system configuration file can be edited to control the system security. The configuration file is located on a partition of a volume allocated as PARM. This minidisk is normally under user ID MAINT, and it is on minidisk address CF1. The file is called SYSTEM CONFIG by default, although its name can be altered during installation. The file is read at IPL time by the CP program that uses the statements, contained in the file, to configure the system.

The following command statements relevant to security are contained in the configuration file:

#### **DEFINE command**

Use the DEFINE command to:

- ▶ Change the configuration of your virtual machine.
- ▶ Change the configuration of your operating system.
- ▶ Add a new alias for an existing CP command on your system.
- ▶ Add a new CP command to your system.
- ▶ Add a new version of an existing CP command to your system.
- ▶ Add a new DIAGNOSE code to your system.
- ▶ Add a new guest LAN to your system.

## DISABLE and ENABLE command

Use DISABLE command to prevent CP from processing requests for the specified CP command during and after initialization.

Useful DISABLE command parameters include:

- ▶ DISABLE Device: Prevents specific devices from accessing the host system.
- ▶ DISABLE Exits: Prevents CP from calling all entry points and external symbols associated with one or more exit points.
- ▶ DISABLE HCD: Prevents HCM and HCD from controlling I/O configuration.
- ▶ DISABLE Diagnose: Prevents CP from processing requests for one or more locally-developed DIAGNOSE codes during and after initialization.

Use ENABLE Diagnose to permit CP to process requests for the specified CP command during and after initialization.

## JOURNALING command

Use the JOURNALING command statement to tell CP whether to include the journaling facility, whether to enable the system being initialized to set and query the journaling facility, and what to do if someone tries to log on to the system or link to a disk without a valid password.

## MODIFY command

Use the MODIFY command to redefine an existing CP command on the system during initialization.

- ▶ MODIFY LAN: Modifies the attributes of an existing guest LAN during initialization.
- ▶ MODIFY Priv\_Classes: Changes the privilege classes authorizing the CP functions that follow it.
- ▶ MODIFY VSWITCH: Modifies the attributes of an existing virtual switch.

**Note:** For a complete description of syntax and usage for the system configuration file, refer to *z/VM: CP Planning and Administration*, SC24-6083.

In the MODIFY command, use the PRIV\_CLASSES statement to change the privilege classes authorizing the following CP functions.

- ▶ SYSTEM\_USERIDS: Specifies user IDs that can perform special functions during and after IPL. These functions include accumulating accounting records, system dump files, EREP records, and symptom records, and specifying the primary system operator's user ID and disconnect status.

- ▶ **USER\_DEFAULTS:** Defines default attributes and permissions for all users on the system.

## 6.1.8 Resource Access Control Facility (RACF)

Resource Access Control Facility (RACF) licensed program can satisfy the preferences of the user without compromising any of the concerns raised by security personnel. The RACF approach to data security is to provide an access control mechanism that offers effective user verification, resource authorization, and logging capabilities. RACF supports the concept of user accountability. It is flexible, has little noticeable effect on the majority of end users, and little or no effect on an installation's current operation. RACF controls access to and protects resources on both multiple virtual storage (z/OS) and virtual machine systems. For a software access control mechanism to work effectively, it must be able to first identify the person who is trying to gain access to the system, and then verify that the user is really that person. With RACF, you are responsible for protecting the system resources, such as minidisks, terminals, and shared file system (SFS) files and directories, and for issuing the authorities by which those resources are made available to users.

RACF records your assignments in profiles stored in the RACF database. RACF then refers to the information in the profiles to decide if a user should be permitted to access a system resource. The ability to log information, such as attempted accesses to a resource, and to generate reports containing that information can prove useful to a resource owner, and is very important to a smoothly functioning security system. Because RACF can identify and verify a user's user ID and recognize which resources the user can access, RACF can record the events where user-resource interaction has been attempted. This function records actual access activities or variances from the expected use of the system.

RACF has a number of logging and reporting functions that allow a resource owner to identify users who attempt to access the resource. In addition, you or your auditor can use these functions to log all detected successful and unsuccessful attempts to access the RACF database and RACF-protected resources. Logging all access attempts allows you to detect possible security exposures or threats. The logging and reporting functions are:

- ▶ **Logging:** RACF writes audit records in a file for detected, unauthorized attempts to enter the system. Optionally, RACF can also writes records for authorized attempts or detected, unauthorized attempts to:
  - Access RACF-protected resources
  - Issue RACF commands
  - Modify profiles on the RACF database

- ▶ Sending messages: RACF sends messages to the security console for detected, unauthorized attempts to enter the system and for detected, unauthorized attempts to access RACF-protected resources or modify profiles on the RACF database.
- ▶ Keeping statistical information: Optionally, RACF can keep selected statistical information, such as the date, time, and number of times that a user enters the system and the number of times a single user accesses a specific resource. This information can help the installation analyze and control its computer operations more effectively. In addition, to allow the installation to track and maintain control over its users and resources, RACF provides commands that enable the installation to list the contents of the profiles in the RACF database.

Several features introduced with z/VM Version 5.3 and RACF Feature Level 5.3 include:

- ▶ Mixed-case 8-character passwords
- ▶ Mixed-case password phrases up to 100 characters, including blanks
- ▶ Not possible to reset password to default group name
- ▶ Audit trail can be unloaded in XML format
- ▶ Remote authorization and audit through z/VM new LDAP server and utilities

**Note:** For more information about RACF, see 2.3.16, “RACF Security Server for z/VM” on page 30.

## 6.2 Defining users

This section discusses the process of defining users or virtual machines in z/VM. It compares this with defining a time sharing option/extension (TSO/E) user, which is very similar to defining an STC user or even a batch user, also. Furthermore, this section illustrates the process on a native z/VM system without using the additional z/VM products, DIRMAINT and RACF. This section does not discuss topics regarding users of transaction systems and similar.

### 6.2.1 z/OS assumptions

This section outlines z/OS aspects of defining users and activities involved in user definition and management on z/OS. In a following section, we discuss the same activities on z/VM.

For more information about maintaining the z/VM user directory, refer to:

- ▶ *z/VM: CP Planning and Administration*, SC24-6083
- ▶ *z/VM:CP Commands and Utilities Reference*, SC24-6081

## Security products

In earlier days, defining users to TSO would imply defining them in the User Attribute Data Set (SYS1.UADS) using the ACCOUNT command. By now, most installations have merged this data set into their RACF data base or similar for ISV products. When UNIX System Services were introduced in OS/390®, it became almost impossible to run a z/OS system without having a security system like RACF or similar activated. As several of the basic system functions of z/OS, for instance TCP/IP, are using or exploiting UNIX System Services, it is very difficult to operate without a security server of some sort. Even some of the installation material states that it is a prerequisite that the user responsible for installing z/OS should have access to different *resource classes* and similar. Without a security product, the standard modules or services performing these checks (SAF) would most certain fail these services.

The UADS (or RACF data base or both) contains data on every TSO user (the RACF base also contains STC and batch idents and other security related data). The base contains the user ID, the associated password, account number or code, the default procedure name and all attributes for each user. Most installations probably implement some kind of grouping or role-based security based on their business. For instance, all system programmers are typically members of the same group defined to RACF, to simplify management of access rules if such grouping has been implemented.

The base itself is stored in an encrypted format, so passwords and other data cannot be retrieved from the base directly. This also applies to independent software vendor (ISV) alternatives.

## A typical process for defining users in z/OS

A typical set of tasks necessary to define a TSO, STC, or batch user in z/OS includes establishing rules for the following areas:

<b>Security product</b>	Users have to be defined to the security server or product, such as RACF.
<b>Storage management</b>	Rules for how to manage the user's data have to be addressed. This could involve adjustment of storage management services (SMS) constructs, defining catalog aliases, preallocating ISPF profiles, and so on.
<b>Other</b>	Several sites are also doing various tailoring for their TSO users, such as adjustment of TSO/ISPF JCL procedures or related services. Accounting might also

be included. A need might also arise for performance-related tasks, such as adjusting WLM policies.

For most z/OS sites, these tasks are performed by different lines or departments within the organization.

## 6.2.2 Defining users in z/VM

This section discusses how users are defined to z/VM. For more details about how to do this, see Chapter 4, “Installing z/VM and creating Linux or z/OS guests” on page 121.

### USER DIRECT file

The z/VM users all have to be defined and maintained in the file USER DIRECT (provided DIRMAINT and RACF are not installed). This file exists in two forms: in one or more *source* forms on one or more CMS files; and in a compiled *object* form on a CP-formatted disk. Only one USER DIRECT can be active at any given instant, but multiple can be accessed. The USER DIRECT is read at IPL time in a predefined search order. First, the system residence volume is searched for a valid object entry. If no such entry exists, all CP-owned volumes are searched, in the order in which they appear (in the CP-owned list). If CP cannot find a valid object, z/VM constructs a default user ID of OPERATOR. By logging on to this user, you can then establish valid USER DIRECT object.

### Source formats of USER DIRECT

The source version of USER DIRECT can exist in two formats: monolithic, in which all statements are contained in one physical file; cluster form, which includes an index file that can point to one or several files containing the necessary statements to build an object USER DIRECT file.

**Note:** All references to USER DIRECT in this book is for the monolithic source format. For further details on the cluster format, refer *z/VM: CP Planning and Administration*, SC24-6083.

### Defining minidisks

User data in z/VM is divided into the minidisk entity. This implies dividing your disk volumes into physical extents with a starting cylinder address and counting the number of cylinders from that.

**Important:** This is very different from z/OS in that z/VM manages (or *allocates* in z/OS terms) user data in *physical* disk extents on the actual volser. These extents are called *minidisks* in z/VM terminology. They can include entire disks.

### 6.2.3 USER DIRECT from a z/OS perspective

The USER DIRECT file contains all data and definitions necessary for a virtual machine to log on to the system. To state it simply, it contains all the data you would define in SYS1.UADS by using the ACCOUNT command. To some extent, it would also contain the similar data and definitions for data storage administration as in z/OS (see “A typical process for defining users in z/OS” on page 293). In addition, USER DIRECT also contains devices and minidisk definitions necessary for each user to log on successfully. This applies to CMS users, VM service machines as well as guest operating systems. The definition of devices and minidisks can be seen as the equivalent of a TSO user’s allocations established by means of the logon procedure JCL.

### 6.2.4 USER DIRECT definitions

Regardless of USER DIRECT source format (monolithic or cluster), definitions must be processed in the following order:

1. DIRECTORY definition: This definition consists of one or more DIRECTORY directory control statements that define the output object directories.
2. Global definition section: This section must begin with the GLOBALDEFS directory control statement. It also includes directory control statements that define global settings to be used for all user definitions.
3. PROFILE definitions: Each definition begins with a PROFILE directory control statement and consolidates other directory control statements that are commonly used for multiple users.
4. USER definitions: This is also called virtual machine definitions. Each begins with a USER directory control statement and defines an individual virtual machine.

The control statements are placed under each of these definitions to form the USER DIRECTORY.

## 6.2.5 DISKMAP command

This command is used to map the disk extents of the z/VM disks. In this section, we pay attention to the disk containing user minidisks, because we are going to define a new CMS user.

**Important:** Use of the DISKMAP command is optional, but it is highly recommended.

DISKMAP reports any gaps or overlaps on these disks. Gaps imply that you are not using the disk fully, whereas overlaps means that users are using the same extent of the disk. The latter implies a potential risk of overwriting data, thus corrupting the disks, and should therefore be avoided.

The command is invoked by issuing:

```
DISKMAP fn ft (DOENDS
```

The `fn` is the file name of the USER DIRECT source you want to examine, and `ft` is its file type. The ending text, `DOENDS`, causes MDISK statements, which had "END" specified for the ending cylinder/block in the directory being mapped, to be included in the DISKMAP output file.

Output from DISKMAP is stored in file `fn DISKMAP` (`fn` is the filename of the mapped file) on the A drive of the user running it.

To run the command `diskmap user`, users must have at least privilege class B. Figure 6-1 on page 297 shows the output of file `USER DISKMAP A` (the output is lengthy so lines have been removed from the figure). Notice the GAP on line 00329 starting at cylinder 1886 for 114 cylinders and ending at 1999.

Based on the output from DISKMAP, minidisks for the user to be defined would have to start in `CYLINDER 2380` so that no overlaps result (see line 00337 for `LYDIA 191` ending in cylinder 2379).



USER	DISKMAP	A1	F	80	Trunc=80	Size=393	Line=240	Col=1	Alt=0
00240	LX6W02	\$ALLOC\$	A03	3390	00000	00000	00001		
00241		40SASF40	2D2	3390	00001	00150	00150		
00242		OSADMIN2	191	3390	00151	00160	00010		
00243		OSADMIN3	191	3390	00161	00170	00010		
-----SNIP-----									
USER	DISKMAP	A1	F	80	Trunc=80	Size=393	Line=320	Col=1	Alt=0
00320		5VMHCD20	2D2	3390	01454	01553	00100		
00321		5VMHCD20	29D	3390	01554	01565	00012		
00322		5VMHCD20	300	3390	01566	01625	00060		
00323		5VMHCD20	400	3390	01626	01685	00060		
00324		CBDIODSP	191	3390	01686	01805	00120		
00325		COSTA	191	3390	01806	01815	00010		
00326		HAIMO	191	3390	01816	01825	00010		
00327		LNXGUI	0191	3390	01826	01835	00010		
00328		COSTA	192	3390	01836	01885	00050		
00329					<b>1886</b>	<b>1999</b>	<b>114</b>		
<b>GAP</b>									
00330		GULL	191	3390	02000	02009	00010		
00331		OMAR	191	3390	02010	02019	00010		
00332		RAY	191	3390	02020	02029	00010		
00333		KEN	191	3390	02030	02039	00010		
00334		CERON	191	3390	02040	02049	00010		
00335		LNXMAINT	191	3390	02050	02069	00020		
00336		LNXMAINT	192	3390	02070	02369	00300		
00337		LYDIA	191	3390	02370	02379	00010		
00338		TOSK	191	3390	02380	02389	00010		
00339		ZOS1	0191	3390	02390	02391	00002		
=====>									

Figure 6-1 Output from DISKMAP

## 6.2.6 Creating and maintaining the USER DIRECT source file

Creating or maintaining the USER DIRECT source file is done by creating a new CMS file or editing the existing USER DIRECT file using the z/VM editor XEDIT. Installations can use this as a template, or users can write their own. When the source file is edited, for instance when a new user has been added, the source file is compiled to object format by using the DIRECTXA command. Maintenance of the USER object (by means of command DIRECTXA) has to be performed from a virtual machine that has privilege class of A, B, or C (or similar installation-defined classes).

It is a good idea to perform a syntax check of the contents of the source file (and run the DISKMAP command to check for possible disk overlaps; see 6.2.5, “DISKMAP command” on page 296).

The syntax for the DIRECTXA command is explained in Figure 6-2.

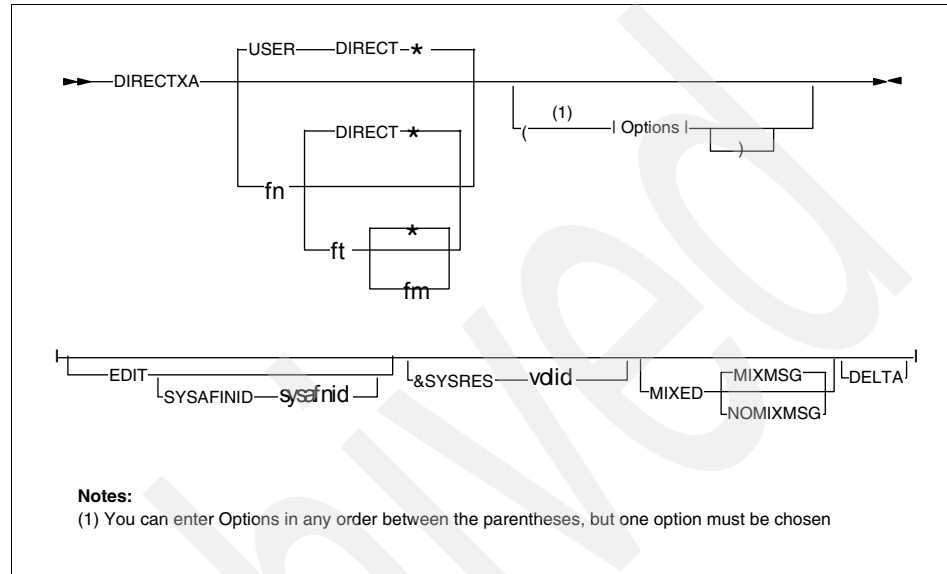

Figure 6-2 Syntax for DIRECTXA command

Note that filename (fn) and file type (ft) have default values of USER and DIRECT, respectively. Therefore, the following commands work the same, if you prefer a different name for the source version of the file (provided files MYDIR DOCUMENT and MYDIR DIRECT exist):

```
DIRECTXA MYDIR DOCUMENT
DIRECTXA MYDIR
```

To check the syntax of the edited source file, issue the command:

```
DIRECTXA fn ft * (EDIT
```

This is a useful function, especially for personnel with limited experience in maintaining this type of file.

As an example, the source file (MYDIR DOCUMENT) contains the statement shown in Figure 6-3 on page 299. Instead of LINK, the administrator entered LUNCH.

```

PROFILE IBMDFLT
SPOOL 000C 2540 READER *
SPOOL 000D 2540 PUNCH A
SPOOL 000E 1403 A
CONSOLE 009 3215 T
LUNCH MAINT 0190 0190 RR
LINK MAINT 019D 019D RR

```

Figure 6-3 Sample MYDIR DOCUMENT

By issuing the following command, the response from DIRECTXA is shown in Figure 6-4.

```
DIRECTXA MYDIR DOCUMENT * (EDIT
```

```

z/VM USER DIRECTORY CREATION PROGRAM – VERSION 5 RELEASE 3.0
LUNCH MAINT 0190 0190 RR
HCPDIR751E INVALID OPERAND – LUNCH FOLLOWING PROFILE IBMDFLT
HCPDIR1775E PROFILE DEFINITION IBMDFLT IS INVALID AND WILL NOT BE PROCESSED FOR
ANY USER DEFINITIONS THAT INCLUDE IT.
EOJ DIRECTORY NOT UPDATED

```

Figure 6-4 Response from DIRECTXA

We now define the new user, with a user ID of TOSK, and define a corresponding 191 minidisk as shown in the USER DIRECT file in Figure 6-5.

```

01967 *****
01968 USER TOSK TOSK 32M 64M G
01969 INCLUDE IBMDFLT
01970 ACCOUNT ACT4 CMSTST
01971 MACH XA
01972 IPL 190
01973 MDISK 191 3390 2380 010 LX6W02 MR READ WRITE MULTIPLE

```

Figure 6-5 Statements to define user TOSK

The line numbers in the file (in Figure 6-5) indicate the following statements:

Line 01968 Statement USER initiates the statements for the user. The first occurrence of TOSK is the user ID, the second is password. The 32M is the initial amount of storage defined to this user, 64M is the maximum amount of storage. The G is the privilege class (or classes) assigned to the user, in this example only a general user

- Line 01969 Includes what is known or defined as a PROFILE in USER DIRECT, and should be seen as statements that are common for several users.
- Line 01970 Assigns account code for the user.
- Line 01971 Sets the architecture for user TOSK
- Line 01972 States that this user should be IPLed from 190, which corresponds to CMS.
- Line 01973 Assigns the minidisk 191 on a 3390 device; starting at cylinder 2380 for 10 cylinders on volume LX6W02 in *multiple read*, establishes passwords for READ (only), WRITE and MULTIPLE READ, respectively. These are used when other users access TOSK's 191.

Invoking the following command gives the response shown in Figure 6-6:

```
DIRECTXA USER DIRECT (EDIT
```

```
Ready: T=0.01/0.01 15:28:21
Directxa user direct (edit
z/VM USER DIRECTORY PROGRAM – VERSION 5 RELEASE 3.0
EOJ DIRECTORY NOT UPDATED
Ready: T=0.01/0.01 15:28:33
```

Figure 6-6 Response from DIRECTXA without errors

To check for disk gaps or overlaps, issue the following command; the response is in Figure 6-7:

```
DISKMAP USER DIRECT (DOENDS
```

```
Diskmap user direct (doends
File USER DISKMAP A has been created.
Ready: T=0.04/0.04 15:39:12
```

Figure 6-7 DISKMAP response

Browsing the USER DISKMAP file shows no gaps or overlaps within this disk's extents, with the exception of MAINT, which is overlapping the same extent. This is because MAINT has this disk (and several others) defined as a minidisk from cylinder 0 to END. This is a normal way of defining CP-owned disks.

Issues the following command to compile the updated source to an object and bring online to z/VM. User ID TOSK can now log on.

```
DIRECTXA USER DIRECT
```

## 6.3 Networking access

This section describes how to give network access to your guest operating systems. We discuss how you define that access for LANs and VSWITCHs.

### DEFINE LAN command

Use this command to create a guest LAN that can be shared among virtual machines on the same VM system. Each guest LAN is identified by a unique combination of *owner ID* and *LAN name*. A VM user can create a simulated network interface card (NIC) and connect it to this LAN segment.

**Note:** The SET LAN command can modify attributes of the guest LAN.

You can also define a LAN during system initialization using the DEFINE LAN configuration file statement. The class B form of the command allows the invoker to create a LAN for another user (for example, OWNERid SYSTEM) and specify whether accounting is *on* or *off* for the LAN being defined.

### DEFINE VSWITCH command

Use this command to create a CP system-owned switch (a virtual switch) to which virtual machines can connect. Each switch is identified by a *switch name*. A z/VM user can create a simulated QDIO network interface card (NIC) and connect it to this switch with the NICDEF directory statement. Under the DEFINE VSWITCH statement, the VLAN parameter is important, but optional, if you want to isolate guests subnets based on VLAN IDs.

## 6.4 Linux on System z resource management

This section discusses the necessary steps to enable dynamically new resources, such as disks, network interface card, can CPU, to a Linux guest.

Explaining the details of Linux on System z hardware detection and configuration is beyond the scope of this book. Nevertheless, providing a brief outline of the processes involved is necessary to help you understand the next section.

### 6.4.1 Hardware detection and configuration

This section discusses device drivers and the in-memory file system.

For additional information about both, refer to *Devices Drivers, Features, and Commands*, SC33-8289. The latest version can be found on Developerworks Web site at:

[http://www.ibm.com/developerworks/linux/linux390/october2005\\_documentation.html](http://www.ibm.com/developerworks/linux/linux390/october2005_documentation.html)

## Devices nodes and udev

The Linux kernel represents the character and block devices it knows as a pair of numbers, *<major>*:*<minor>*. Certain major numbers are reserved for particular device drivers, others are dynamically assigned to a device driver when Linux boots. For example, major number 94 is always the major number for DASD devices but the device driver for channel-attached tape devices has no fixed major number. A major number can also be shared by multiple device drivers.

The device driver uses the *<minor>* number to distinguish individual physical or logical devices. For example, the DASD device driver assigns four minor numbers to each DASD: one to the DASD as a whole and the other three for up to three partitions. Device drivers assign device names to their devices, according to a device driver-specific naming scheme. Each device name is associated with a minor number.

Historically, Linux provides a large set of predefined device nodes in the */dev* directory. Most of the time, only a small subset of these device nodes were used. With Linux 2.6, things changed: only a small number of predefined device nodes are in the */dev* directory; and a user-space daemon, *udev*, is in charge of creating the required device nodes in */dev* dynamically when notified by the kernel that a new device is plugged in. *Udev* can also be used to *tune* the device node names to fit an organization's needs or set permissions on nodes, for instance.

For information about *udev* capabilities, see the *udev* manual page (man 7 *udev*).

## */sys* filesystem

After a device has been brought online in Linux, device drivers expose their parameters to the userspace through an in-memory file system called */sys*.

**Note:** */sys* filesystem does not exist on disk. It is re-created each time a Linux guest IPLs.

*/sys* is the successor of */proc* filesystem, which still exists for downward compatibility.

The */sys* filesystem allows initialization scripts or users to interact with the drivers parameters to query or modify the configuration.

## 6.4.2 Disk management

### Enabling a disk in Linux

After the new disk has been defined, is in the directory, and is dynamically attached to the guest (as explained in section 5.3.9, “Managing DASD” on page 258), it can be enabled in Linux.

Use the `lscss` command, which stands for *List Channel Subsystem* to show all the devices that are attached to your system. Example 6-1 shows the output of the `lscss` command before and after attaching the disk as device 0200.

*Example 6-1 The lscss command output, before and after attaching new DASD to guest*

```
Inxguill:~ # lscss
-----
Device  Subchan.  DevType CU Type Use  PIM PAM POM  CHPIDs
-----
0.0.0191 0.0.0000  3390/0A 3990/E9      F0 F0 FF  52565A5E 00000000
0.0.0100 0.0.0001  3390/0C 3990/E9 yes  F0 F0 FF  5054585C 00000000
0.0.0101 0.0.0002  9336/10 6310/80 yes  80 80 FF  00000000 00000000
0.0.0150 0.0.0003  3390/0C 3990/E9 yes  F0 F0 FF  5054585C 00000000
[...]
Inxguill:~ # lscss
-----
Device  Subchan.  DevType CU Type Use  PIM PAM POM  CHPIDs
-----
0.0.0191 0.0.0000  3390/0A 3990/E9      F0 F0 FF  52565A5E 00000000
0.0.0100 0.0.0001  3390/0C 3990/E9 yes  F0 F0 FF  5054585C 00000000
0.0.0101 0.0.0002  9336/10 6310/80 yes  80 80 FF  00000000 00000000
0.0.0150 0.0.0003  3390/0C 3990/E9 yes  F0 F0 FF  5054585C 00000000
[...]
0.0.0200 0.0.0012  3390/0C 3990/E9      F0 F0 FF  5054585C 00000000
Inxguill:~ #
```

At this point, the disk is seen by Linux, but it has to be enabled for the operating system to be able to use it. The disk is enabled with `chccwdev` command, as shown in Example 6-2, is provided by IBM and delivered in the `s390-tools` package.

*Example 6-2 Enabling a disk for Linux*

```
Inxguill:~ # chccwdev -e 0.0.0200
Setting device 0.0.0200 online
Done
Inxguill:~ #
```

To enable a device, use the `-e` switch; to disable a device, use the `-d` switch. When the disk is brought online, the Linux kernel assigns the disk a device node

name, which is used for referring to the disk. The device node name attributed to the disk can be found using the `lsdasd` command, as shown in Example 6-3.

*Example 6-3 Defining the device node name*

---

```
Inxguill:~ # lsdasd
0.0.0100(ECKD) at ( 94: 0) is dasda      : active at blocksize 4096, 126000
blocks, 492 MB
0.0.0101(FBA ) at ( 94: 4) is dasdb      : active at blocksize 512, 200000
blocks, 97 MB
0.0.0150(ECKD) at ( 94: 8) is dasdc      : active at blocksize 4096, 456840
blocks, 1784 MB
0.0.0200(ECKD) at ( 94: 12) is dasdd     : active at blocksize 4096, 1802880
blocks, 7042 MB
```

---

The device 0200 (as defined in z/VM DIRECTORY) will be accessed by Linux through node `/dev/dasdd`.

**Note:** It is also possible to add disks thanks to YaST graphical interface. Go to **Hardware** → **DASD**, select the device you want to enable for Linux, and then select **Activate** in the list.

Depending on the intended use of the disk device, you might have to create a file system on it before using it.

## Making changes permanent

The steps described so far, allows an administrator to dynamically add a disk device to a running Linux, without having to reboot. But, at next IPL, changes will be lost.

To make changes permanent in SLES10:

1. Create a configuration file for the device in `/etc/sysconfig/hardware`, using the template in `/etc/sysconfig/hardware/skel/hwcfg-dasd-eckd`. This file will be used at IPL to set up the DASD driver accordingly.
2. Make sure the Linux device nodes are created in the correct order. Do this by rebuilding the initial ramdisk and rebuilding the boot record each time a new DASD is added to Linux, as shown in Example 6-4.

*Example 6-4 Rebuild ramdisk, and update boot record*

---

```
Inxguill:/etc/sysconfig/hardware # mkinitrd
Root device:   /dev/dasda1 (mounted on / as ext3)
Module list:   jbd ext3 dasd_eckd_mod dasd_fba_mod (xen-net xenblk)

Kernel image: /boot/image-2.6.16.21-0.8-default
```



```

Initrd image: /boot/initrd-2.6.16.21-0.8-default
Shared libs: lib64/ld-2.4.so lib64/libacl.so.1.1.0
lib64/libattr.so.1.1.0 lib64/libblkid.so.1.0 lib64/libc-2.4.so
lib64/libcom_err.so.2.1 lib64/libdl-2.4.so lib64/libext2fs.so.2.4
lib64/libhistory.so.5.1 lib64/libncurses.so.5.5 lib64/libpthread-2.4.so
lib64/libreadline.so.5.1 lib64/librt-2.4.so lib64/libuuid.so.1.2
Driver modules: dasd_mod dasd_eckd_mod dasd_fba_mod
DASDs: 0.0.0100(ECKD) 0.0.0101(FBA) 0.0.0150(ECKD) 0.0.0200(ECKD)
Filesystem modules: jbd ext3
Including: initramfs fsck.ext3
17062 blocks

initrd updated, zipl needs to update the IPL record before IPL!
lnxguill:/etc/sysconfig/hardware # zipl
Using config file '/etc/zipl.conf'
Building bootmap in '/boot/zipl'
Building menu 'menu'
Adding #1: IPL section 'ipl' (default)
Adding #2: IPL section 'failsafe'
Preparing boot device: dasda (0100).
Done.
lnxguill:/etc/sysconfig/hardware #

```

---

**Note:** For certain device drivers, the assignment of minor numbers and names can change between kernel boots, when devices are added or removed in a VM environment, or even if devices are set offline and back online. The same file name, therefore, can lead to a completely different device.

We rebuild the initial ramdisk to ensure all your disks are brought online at IPL, in the order you activated them.

To make the changes permanent in RHEL5:

1. Update the `/etc/modprobe.conf` file by adding the new DASD at the end of options line `dasd_mod=`, as shown in Example 6-5.:

*Example 6-5 Updating modprobe.conf*

```

[root@mbase40 etc]# cat /etc/modprobe.conf
options dasd_mod dasd=0100,0150,0101,200
alias eth0 qeth
alias hsi0 qeth

```

---

2. Rebuild the initial ramdisk and update the boot record, as shown in Example 6-6 on page 306.

*Example 6-6 Re-creating the initial ramdisk and updating boot record in RHEL5*

---

```
[root@mbase40 etc]# mkinitrd -v /boot/initrd-2.6.18-8.1.3.el5.img
2.6.18-8.1.3.el5
Creating initramfs
Looking for deps of module uhci-hcd
Looking for deps of module ohci-hcd
Looking for deps of module ehci-hcd
Looking for deps of module ext3: jbd
Looking for deps of module jbd
Looking for driver for device dasda1
Looking for deps of module ccw:t3990mE9dt3390dm0C: dasd_mod dasd_eckd_mod
Looking for deps of module dasd_mod
Looking for deps of module dasd_eckd_mod: dasd_mod
Looking for driver for device dasdc1
Looking for deps of module ccw:t6310m80dt9336dm10: dasd_mod dasd_fba_mod
Looking for deps of module dasd_fba_mod: dasd_mod
Looking for deps of module ide-disk
Using modules:    /lib/modules/2.6.18-8.1.3.el5/kernel/fs/jbd/jbd.ko
/lib/modules/2.6.18-8.1.3.el5/kernel/fs/ext3/ext3.ko
/lib/modules/2.6.18-8.1.3.el5/kernel/drivers/s390/block/dasd_mod.ko
/lib/modules/2.6.18-8.1.3.el5/kernel/drivers/s390/block/dasd_eckd_mod.ko
/lib/modules/2.6.18-8.1.3.el5/kernel/drivers/s390/block/dasd_fba_mod.ko
/sbin/nash -> /tmp/initrd.s14762/bin/nash
/sbin/insmod.static -> /tmp/initrd.s14762/bin/insmod
copy from `~/lib/modules/2.6.18-8.1.3.el5/kernel/fs/jbd/jbd.ko' [elf64-s390]
to `~/tmp/initrd.s14762/lib/jbd.ko' [elf64-s390]
copy from `~/lib/modules/2.6.18-8.1.3.el5/kernel/fs/ext3/ext3.ko'
[elf64-s390] to `~/tmp/initrd.s14762/lib/ext3.ko' [elf64-s390]
copy from
~/lib/modules/2.6.18-8.1.3.el5/kernel/drivers/s390/block/dasd_mod.ko'
[elf64-s390] to `~/tmp/initrd.s14762/lib/dasd_mod.ko' [elf64-s390]
copy from
~/lib/modules/2.6.18-8.1.3.el5/kernel/drivers/s390/block/dasd_eckd_mod.ko'
[elf64-s390] to `~/tmp/initrd.s14762/lib/dasd_eckd_mod.ko' [elf64-s390]
copy from
~/lib/modules/2.6.18-8.1.3.el5/kernel/drivers/s390/block/dasd_fba_mod.ko'
[elf64-s390] to `~/tmp/initrd.s14762/lib/dasd_fba_mod.ko' [elf64-s390]
Adding module jbd
Adding module ext3
Adding module dasd_mod with options dasd=0100,0150,0101,200
Adding module dasd_eckd_mod
Adding module dasd_fba_mod
```

---

**Note:** The syntax of `mkinitrd` command is different between RHEL5 and SLES10.

## Linux Logical Volume Manager

Linux systems offer a feature to manage disks when you initially do not know how much space your partitions will consume: the Logical Volume Manager (LVM). LVM allows you to join disks together to form a single bigger logical disk, and then organize your partitions on this logically bigger disk. Figure 6-8 shows an example of managing disks under LVM.

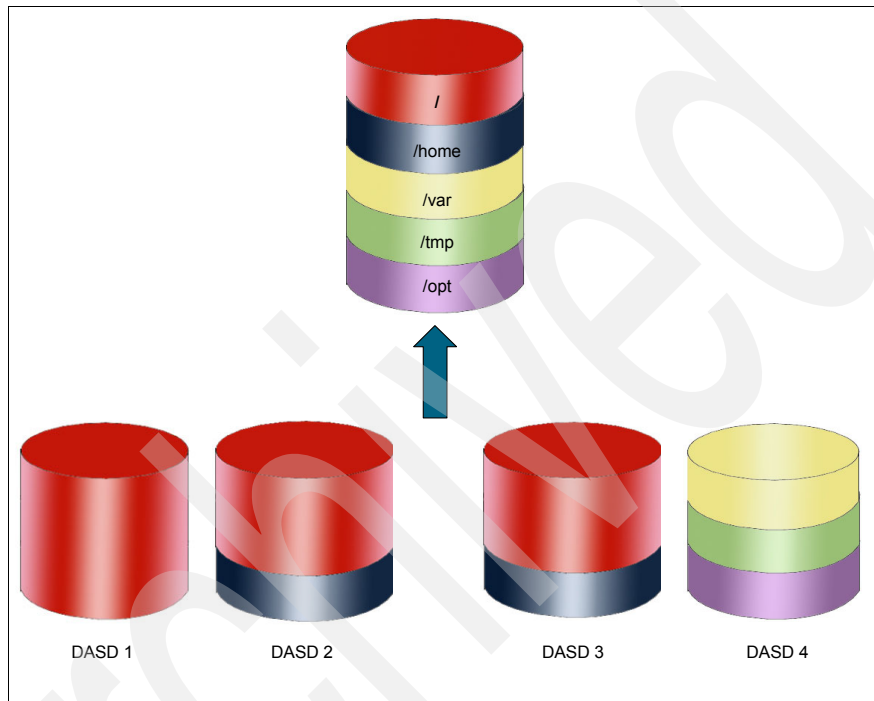

Figure 6-8 Linux LVM managing four DASDs.

As you can see, the four DASDs (1, 2, 3, and 4) are being used to form a single logical disk that holds the system's partitions. The root filesystem (/) is *in reality* allocated on three different DASDs. The system does not know or care about this because the LVM code handles address translations and accesses the data on the real disks. The /home partition is also spread across two DASDs, and the /var, /tmp and /opt partitions are on a single DASD.

In section 4.4, "Installing Linux" on page 171, we chose to make room for its root filesystem over multiple 3390-3 volumes. Assume, for example, that the 3 GB /home partition that we created just ran out of space and we want to give it more space. The traditional way of resolving this problem is to bring a new DASD into the system, bigger than the one hosting the /home partition, and to move its

contents to the new disk area. This is very awkward, time consuming, and error prone. With LVM, though, this becomes an easy task.

Extending a *logical volume*, such as the `/var` partition of our Linux installation, is a matter of adding one more disk or stripe of a disk to the logical group so that this new space can be given to any of its logical volumes. In a rough analogy, this is similar to building a new room to the side of your living room and later removing the wall between them. You are left with the exact same living room and extra space. Figure 6-9 illustrates this in terms of disks.

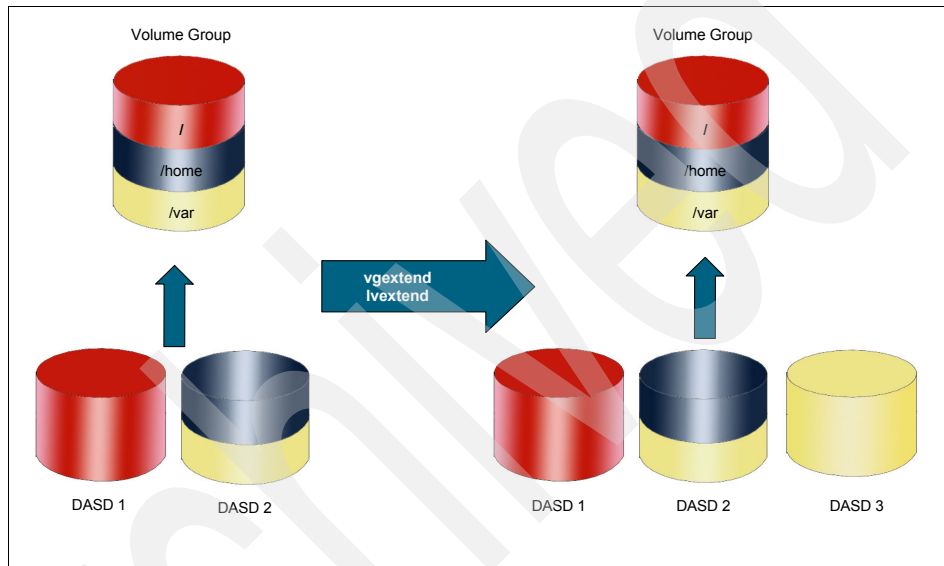

Figure 6-9 Expanding a Linux partition by adding more DASD to LVM

Various Linux distributions, such as YaST, provide mechanisms for users to interact with LVM through a user interface. In systems where this is not available, commands can also accomplish LVM management. Several commands to know about are:

- pvcreate** Creates a *physical volume* entry on the disk, so that LVM knows about it.
- vgscan** Scans all disks for volume groups and builds the files `/etc/lvmtab` and `/etc/lvmtab.d/*` that are the databases for all other LVM commands.
- vgcreate** Creates a volume group by using the disks passed as parameters. These disks must first be initialized with **pvcreate**.
- vgextend** Adds a disks to a volume group. The disks must first be initialized with **pvcreate**.

- lvcreate** Creates a logical volume inside a volume group.
- lvremove** Removes a logical volume from a volume group. You should use this only on empty volumes or volumes whose data is not of interest to you anymore.
- lvextend** Extends a logical volume by using unallocated storage space in the volume group.

To expand our 3 GB /home partition:

1. As z/VM MAINT, attach another 3390-3 DASD to our z/VM system.
2. As z/VM MAINT, define a minidisk on it and assign it to our Linux guest.
3. As Linux root, use **vgextend** to add it to our volume group.
4. As Linux root, use **lvextend** to expand our /home logical volume by using the newly added storage space to the volume group.

For a more detailed discussion about Linux LVM and how to use it, refer to *Linux for IBM eServer zSeries and S/390: Distributions*, SG24-6264.

You can also refer to the *LVM HOWTO* at:

<http://tldp.org/HOWTO/LVM-HOWTO/>

For a performance discussion on LVM itself, refer to:

- ▶ Disk performance optimizing:  
[http://www.ibm.com/developerworks/linux/linux390/perf/tuning\\_rec\\_dasd\\_optimizedisk.html](http://www.ibm.com/developerworks/linux/linux390/perf/tuning_rec_dasd_optimizedisk.html)
- ▶ Volume management:  
[http://www.ibm.com/developerworks/linux/linux390/perf/tuning\\_rec\\_dasd\\_volMan.html](http://www.ibm.com/developerworks/linux/linux390/perf/tuning_rec_dasd_volMan.html)

### 6.4.3 Network management

This section details the steps required to add an additional network interface to a running Linux guest; then connecting this interface to a VSWITCH, a GUEST-LAN, or a Hipersocket network. After the network connectivity of the guest is established, configure Linux (SLES 10 or RHEL 5).

#### **SUSE Linux Enterprise Server 10 (SLES 10)**

To configure Linux to use the connection:

1. Make sure the devices are seen by Linux; we use the **lscss** command (Example 6-7 on page 310).

*Example 6-7 Checking the availability of the new devices*

```
Inxguill:~ # lscss
Device   Subchan.  DevType CU Type Use  PIM PAM POM  CHPIDs
-----
0.0.0191 0.0.0000  3390/0A 3990/E9   F0 F0 FF  52565A5E 00000000
0.0.0100 0.0.0001  3390/0C 3990/E9 yes F0 F0 FF  5054585C 00000000
[...]
0.0.0200 0.0.0012  3390/0C 3990/E9   F0 F0 FF  5054585C 00000000
0.0.0D20 0.0.0013  1732/01 1731/01   80 80 80  21000000 00000000
0.0.0D21 0.0.0014  1732/01 1731/01   80 80 80  21000000 00000000
0.0.0D22 0.0.0015  1732/01 1731/01   80 80 80  21000000 00000000
```

2. Create a new configuration file in /etc/sysconfig/hardware (Example 6-8).

*Example 6-8 Creating a new configuration file*

```
Inxguill:/etc/sysconfig/hardware # cp -arv skel/hwcfg-qeth
hwcfg-qeth-bus-ccw-0.0.0d20
`skel/hwcfg-qeth' -> `hwcfg-qeth-bus-ccw-0.0.0d20'
```

3. Update the configuration file to reflect the Linux network hardware configuration, especially the CCW\_CHAN\_IDS and CCW\_CHAN\_MODE, which specify a port name (Example 6-9).

*Example 6-9 Updating the network hardware configuration file*

```
#!/bin/sh
#
# hwcfg-qeth
#
# Default configuration for a qeth device
# $Id: hwcfg-qeth 1069 2004-09-02 18:23:18Z zoz $
#

STARTMODE="auto"
MODULE="qeth_mod"
MODULE_OPTIONS=""
MODULE_UNLOAD="yes"

# Scripts to be called for the various events.
SCRIPTUP="hwup-ccw"
SCRIPTUP_ccw="hwup-ccw"
SCRIPTUP_ccwgroup="hwup-qeth"
SCRIPTDOWN="hwdown-ccw"

# CCW_CHAN_IDS sets the channel IDs for this device
# The first ID will be used as the group ID
CCW_CHAN_IDS="0.0.0d20 0.0.0d21 0.0.0d22"
```

```

# CCW_CHAN_NUM set the number of channels for this device
# Always 3 for an qeth device
CCW_CHAN_NUM=3

# CCW_CHAN_MODE sets the port name for an OSA-Express device
# CCW_CHAN_MODE="Z44LAN01"

# QETH_OPTIONS sets additional options for the OSA-Express or
# HiperSockets device. Valid parameters are:
# add_hhlen buffer_count broadcast_mode canonical_macaddr checksumming
# fake_broadcast fake_ll priority_queueing route4 route6
# QETH_OPTIONS="fake_ll=1"

# QETH_IPA_TAKEOVER enables IP address takeover for this device
# QETH_IPA_TAKEOVER=0

```

---

**Important:** Devices numbers must be lowercase.

4. Create the network configuration file in `/etc/sysconfig/network` (Example 6-10).

*Example 6-10 Creating the network configuration file*

```

lnxguill:/etc/sysconfig/network # cp -arv ifcfg-qeth-bus-ccw-0.0.0600
ifcfg-qeth-bus-ccw-0.0.0d20
`ifcfg-qeth-bus-ccw-0.0.0600' -> `ifcfg-qeth-bus-ccw-0.0.0d20'

```

---

5. Update the configuration file with your TCP/IP configuration (Example 6-11).

*Example 6-11 Updating TCP/IP configuration*

```

lnxguill:/etc/sysconfig/network # cat ifcfg-qeth-bus-ccw-0.0.0d20
BOOTPROTO="static"
UNIQUE=""
STARTMODE="onboot"
IPADDR="172.0.0.1"
NETMASK="255.255.255.0"
NETWORK="172.0.0.0"
BROADCAST="172.0.0.255"

```

---

6. Enable the network interface in Linux (Example 6-12).

*Example 6-12 Enabling the network interface*

```

lnxguill:/etc/sysconfig/hardware # echo '0.0.0d20,0.0.0d21,0.0.0d22' >
/sys/bus/ccwgroup/drivers/qeth/group
lnxguill:/etc/sysconfig/hardware # echo 1 >
/sys/devices/qeth/0.0.0d20/online

```

---

7. Make sure the devices have been brought online (Example 6-13).

*Example 6-13 Checking the devices have been brought online*

---

```
Inxguill:/etc/sysconfig/hardware # lscss
Device  Subchan.  DevType CU Type Use  PIM PAM POM  CHPIDs
-----
0.0.0191 0.0.0000  3390/0A 3990/E9    F0 F0 FF  52565A5E 00000000
0.0.0100 0.0.0001  3390/0C 3990/E9 yes  F0 F0 FF  5054585C 00000000
[...]
0.0.0200 0.0.0012  3390/0C 3990/E9    F0 F0 FF  5054585C 00000000
0.0.0D20 0.0.0013  1732/01 1731/01 yes  80 80 80  21000000 00000000
0.0.0D21 0.0.0014  1732/01 1731/01 yes  80 80 80  21000000 00000000
0.0.0D22 0.0.0015  1732/01 1731/01 yes  80 80 80  21000000 00000000
```

---

8. Reload the network configuration, using the `rcnetwork service restart` command (Example 6-14).

*Example 6-14 Restarting the network configuration service*

---

```
Inxguill:/etc/sysconfig/hardware # rcnetwork restart
Shutting down network interfaces:
  eth0
  eth0      configuration: qeth-bus-ccw-0.0.0600      done
  eth1
  eth1      configuration: qeth-bus-ccw-0.0.0d20      done
Shutting down service network . . . . . done
Hint: you may set mandatory devices in /etc/sysconfig/network/config
Setting up network interfaces:
  lo
  lo      IP address: 127.0.0.1/8      done
  eth0
  eth0      configuration: qeth-bus-ccw-0.0.0600
  eth0      IP address: 9.12.5.66/23      done
  eth1
  eth1      configuration: qeth-bus-ccw-0.0.0d20
  eth1      IP address: 172.0.0.1/24      done
Setting up service network . . . . . done
```

---

9. Check the Linux TCP/IP configuration, to make sure a new interface has been created (Example 6-15).

*Example 6-15 Checking the Linux TCP/IP configuration*

---

```
Inxguill:/etc/sysconfig/hardware # ifconfig -a
[...]

eth1      Link encap:Ethernet  HWaddr 02:00:01:00:00:05
          inet addr:172.0.0.1  Bcast:172.0.0.255  Mask:255.255.255.0
          inet6 addr: fe80::200:100:100:5/64  Scope:Link
```



```
UP BROADCAST RUNNING MULTICAST MTU:1492 Metric:1
RX packets:0 errors:0 dropped:0 overruns:0 frame:0
TX packets:12 errors:0 dropped:0 overruns:0 carrier:0
collisions:0 txqueuelen:1000
RX bytes:0 (0.0 b) TX bytes:936 (936.0 b)
```

[...]

---

## Red Hat Enterprise Linux 5 (RHEL 5)

To configure Linux to use the connection:

1. Make sure the devices are seen by Linux; we use the `lscss` command (Example 6-16).

*Example 6-16 Checking the availability of the new devices*

---

```
lnxguill:~ # lscss
Device  Subchan.  DevType CU Type Use  PIM PAM POM  CHPIDs
-----
0.0.0191 0.0.0000  3390/OA 3990/E9      F0 F0 FF  52565A5E 00000000
0.0.0100 0.0.0001  3390/OC 3990/E9 yes  F0 F0 FF  5054585C 00000000
[...]
0.0.0200 0.0.0012  3390/OC 3990/E9      F0 F0 FF  5054585C 00000000
0.0.0D20 0.0.0013  1732/01 1731/01      80 80 80  21000000 00000000
0.0.0D21 0.0.0014  1732/01 1731/01      80 80 80  21000000 00000000
0.0.0D22 0.0.0015  1732/01 1731/01      80 80 80  21000000 00000000
```

---

2. Create a new alias for your network interface in file `/etc/modprobe.conf` to tell the kernel to use the `qeth` driver to configure the `eth1` network interface (Example 6-17).

*Example 6-17 Creating an alias*

---

```
[root@mbase40 etc]# cat modprobe.conf
options dasd_mod dasd=0100,0150,0101,200
alias eth0 qeth
alias eth1 qeth
```

---

3. Create the configuration file for the new network interface card, `eth1` (Example 6-18).

*Example 6-18 Creating the new the network configuration file*

---

```
[root@mbase40 etc]# cat /etc/sysconfig/network-scripts/ifcfg-eth1
DEVICE=eth1
BOOTPROTO=static
BROADCAST=172.0.0.255
IPADDR=172.0.0.1
NETMASK=255.255.255.0
```

```
NETTYPE=qeth
NETWORK=172.0.0.0
ONBOOT=yes
PORTNAME=
SUBCHANNELS=0.0.0d20,0.0.0d21,0.0.0d22
TYPE=Ethernet
```

---

**Important:** Devices numbers have to be lowercase.

4. Enable the network interface in Linux (Example 6-19).

*Example 6-19 Enabling the network interface*

---

```
[root@mbase40 etc]# echo '0.0.0d20,0.0.0d21,0.0.0d22' >
/sys/bus/ccwgroup/drivers/qeth/group
[root@mbase40 etc]# echo 1 > /sys/devices/qeth/0.0.0d20/online
```

---

5. Make sure the devices have been brought online (Example 6-20).

*Example 6-20 Checking the devices have been brought online*

---

```
[root@mbase40 etc]# lscss
Device  Subchan.  DevType CU Type Use  PIM PAM POM  CHPIDs
-----
0.0.0191 0.0.0000  3390/OA 3990/E9      F0 F0 FF  52565A5E 00000000
0.0.0100 0.0.0001  3390/OC 3990/E9 yes  F0 F0 FF  5054585C 00000000
[...]
0.0.0200 0.0.0012  3390/OC 3990/E9      F0 F0 FF  5054585C 00000000
0.0.0D20 0.0.0013  1732/01 1731/01 yes  80 80 80  21000000 00000000
0.0.0D21 0.0.0014  1732/01 1731/01 yes  80 80 80  21000000 00000000
0.0.0D22 0.0.0015  1732/01 1731/01 yes  80 80 80  21000000 00000000
```

---

6. Reload the network configuration, using the `rcnetwork service restart` command (Example 6-21).

*Example 6-21 Restarting the network configuration service*

---

```
[root@mbase40 etc]# service network restart
Shutting down interface eth0: [ OK ]
Shutting down interface eth1: [ OK ]
Shutting down loopback interface: [ OK ]
Bringing up loopback interface: [ OK ]
Bringing up interface eth0: [ OK ]
Bringing up interface eth1: [ OK ]
```

---

7. Check the Linux TCP/IP configuration to make sure a new interface has been created (Example 6-22 on page 315).

*Example 6-22 Checking the Linux TCP/IP configuration*

---

```
[root@mbase40 etc]# ifconfig -a
[...]
```

```
eth1      Link encap:Ethernet  HWaddr 02:00:01:00:00:05
          inet addr:172.0.0.1  Bcast:172.0.0.255  Mask:255.255.255.0
          inet6 addr: fe80::200:100:100:5/64  Scope:Link
          UP BROADCAST RUNNING MULTICAST  MTU:1492  Metric:1
          RX packets:0 errors:0 dropped:0 overruns:0 frame:0
          TX packets:12 errors:0 dropped:0 overruns:0 carrier:0
          collisions:0 txqueuelen:1000
          RX bytes:0 (0.0 b)  TX bytes:936 (936.0 b)
```

```
[...]
```

---

## 6.4.4 CPU management

When running Linux under z/VM, you can dynamically add (without having to re-IPL) virtual CPUs to a guest that has been prepared accordingly.

### Setting up

Review the LNXGUI directory entry and modify its initialization parameters.

#### ***LNXGUI directory entry***

LNXGUI directory is a virtual machine running ESA architecture, supporting up to four CPUs. At IPL, two CPUs are defined in the guest. See Example 6-23.

*Example 6-23 Extract of LNXGUI directory entry*

---

```
MACHINE ESA 4
CPU 00 BASE
CPU 01
```

---

#### ***LNXGUI initialization parameters***

On the Linux side, you must tell the kernel that it can use more CPUs than it has effectively detected at IPL. This is done by adding the option `additional_cpus` to the `zipl.conf` parameter line, as shown in Example 6-24.

*Example 6-24 LNXGUI zipl.conf*

---

```
# Modified by YaST2. Last modification on Tue May 20 19:07:54 UTC 2008
[defaultboot]
defaultmenu = menu

[...]
```

```

###Don't change this comment - YaST2 identifier: Original name: ipl###
[ipl]
  target = /boot/zipl
  image = /boot/image
  ramdisk = /boot/initrd,0x1000000
  parameters = "root=/dev/dasda1 TERM=dumb additional_cpus=2"
[...]
```

---

After updating the file `/etc/zipl.conf`, you must update the boot record to reflect the new configuration by running the command `zipl`. Reboot Linux for changes to take effect.

### Adding a virtual CPU to a running Linux guest

If the guest is correctly set up, you may add CPUs to a running Linux guest, as follows:

1. Define a new CPU in the Linux virtual machine by using the class G command `DEFINE CPU` (Example 6-25).

*Example 6-25 Define a new virtual CPU in the Linux virtual machine*

---

```

00: CPU 00 ID FF04DE5020978000 (BASE) CP CPUAFF ON
00: CPU 01 ID FF04DE5020978000 CP CPUAFF ON
00:
00: CP DEFINE CPU 02
00: CPU 02 defined
00:
00: CP Q CPUS
00: CPU 00 ID FF04DE5020978000 (BASE) CP CPUAFF ON
00: CPU 01 ID FF04DE5020978000 CP CPUAFF ON
00: CPU 02 ID FF04DE5020978000 CP CPUAFF ON
```

---

The virtual machine had two CPUs active at IPL, it now has three. The Linux guest has no knowledge yet of this extra CPU power available, as shown Example 6-26.

*Example 6-26 Initial CPU configuration*

---

```

Inxguill:~ # cat /proc/cpuinfo
vendor_id      : IBM/S390
# processors   : 2
bogomips per cpu: 3735.55
processor 0: version = FF, identification = 04DE50, machine = 2097
processor 1: version = FF, identification = 04DE50, machine = 2097
```

---

2. Activate the CPU in Linux by issuing the following command:

```
lnxguill:~ # echo 1 > /sys/devices/system/cpu/cpu2/online
```

The following message is listed in the log files when the CPU has been activated:

```
Jun 12 15:04:00 lnxguill kernel: cpu 2 phys_idx=2 vers=FF  
ident=04DE50 machine=2097 unused=8000
```

3. As an administrator, check the number of CPUs seen by Linux by using the **cat /proc/cpuinfo** command, as shown in Example 6-27.

*Example 6-27 Querying the number of CPUs*

---

```
lnxguill:~ # cat /proc/cpuinfo  
vendor_id      : IBM/S390  
# processors   : 3  
bogomips per cpu: 3735.55  
processor 0: version = FF, identification = 04DE50, machine = 2097  
processor 1: version = FF, identification = 04DE50, machine = 2097  
processor 2: version = FF, identification = 04DE50, machine = 2097
```

---

Archived

# Performance monitoring and system analysis

In this chapter, we introduce z/VM scheduling concepts and monitoring commands, and relate those commands to z/OS equivalents. We also introduce z/VM monitoring tools and performance tuning concepts. The chapter also discusses concepts and techniques related to monitoring Linux running on System z.

## Objectives

After completing this chapter, you should be able to:

- ▶ Understand the basics of z/VM scheduling concepts
- ▶ Understand the usage of CP commands related to performance monitoring
- ▶ Describe z/OS commands and monitoring concepts
- ▶ Identify the monitoring tools available for z/VM
- ▶ Discuss system monitoring best practices

## 7.1 Monitoring z/VM

This section introduces z/VM scheduling basics, and System z/VM and Linux monitoring commands.

Many aspects can be considered when you look at the performance of a z/VM system, including the following areas:

- ▶ User response time
- ▶ Throughput
- ▶ Device utilization
- ▶ Number of users supported
- ▶ Reliability
- ▶ System capacity

If you are familiar with z/OS, you might have heard about or worked with the z/OS Workload Manager (WLM) component. It provides the ability to dynamically allocate or redistribute server resources, such as CPU, I/O, and memory, for a set of workloads based on user-defined goals and their resource demand within a z/OS image.

For more information about the z/OS WLM, refer to:

<http://www-03.ibm.com/servers/eserver/zseries/zos/wlm/pdf/zWLM.pdf>

### 7.1.1 z/VM scheduling

To understand z/VM performance parameters and factors, it is important to be aware of the underlying system scheduling.

In z/OS, job control language (JCL) is used to tell the system which programs to execute, followed by a description of program inputs and outputs. JCL consists of a series of statements, each of which provides specific instructions or information for batch processing jobs. It provides the system with a source of information about details such as the programs to execute, the location of required data sets, the department to be billed for CPU processing time, and the job priority. The system uses a job entry subsystem (JES) to receive jobs into the operating system, schedule them for processing by MVS, and control their output processing. JES2 and the base control program (BCP) provide the necessary functions to get jobs into, and output from the MVS system.



z/VM employs similar scheduling concepts where the Control Program (CP) and the Scheduler cooperate to perform the scheduling tasks, which involve a number of components illustrated in Figure 7-1.

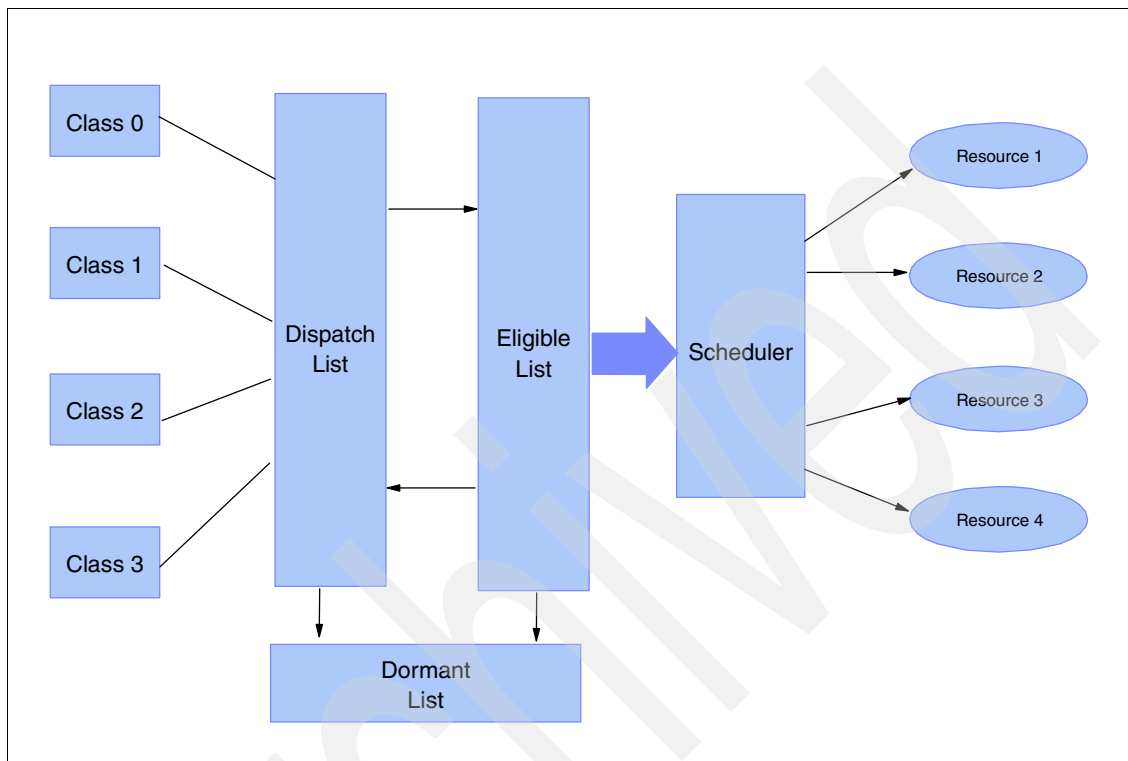

Figure 7-1 z/VM scheduling components

### The scheduling components

The scheduling components and how they all work together are described in this section.

#### ***Dormant list***

If any virtual machine is not doing any processing, the CP moves it to the dormant list. The virtual machine is now *asleep*.

#### ***Eligible list***

A sleeping virtual machine can *wake up* in response to an event, such as pressing the Enter key on the console for example. The virtual machine is then moved to the eligible list and it becomes *eligible* to consume system resources.

### **Scheduler**

The scheduler examines the list of eligible virtual machines before they are given system resources. Specifically, the scheduler looks at the virtual machines definition (VMDBK) information for resources that have been consumed in the past, such as processor, storage, and paging.

### **Dispatch list**

If the scheduler determines that enough resources are available to satisfy your requirements without putting any other virtual machine in jeopardy, the virtual machine is moved to the dispatch list.

### **Time slice**

Virtual machines in the dispatch list wait in a queue for their share of CPU time, usually referred to as a time slice. Virtual machines that have more work to do can stay in the dispatch list to get another time slice.

### **User classes**

When you first log on to z/VM, the Control Program creates an area of storage that contains information pertinent to the operation that you are associated with. This storage area is called a Virtual Machine Definition Block (VMDBK). Pointers to this block get moved around the lists as shown in Figure 7-1 on page 321.

## **Scheduling and user classes**

z/VM categorizes users under four distinct classes. User class affects how the scheduler handles the user's scheduling scheme. For example, users in class 1 are assumed to be running short processing transactions. Users in this class are given times slices and are expected to complete their processing within that time slice. However, if users have visited the dispatch list more than once and have not completed their processing, the dispatcher can upgrade the user to class 2. Class 2 users are allowed to stay in dispatch list for longer intervals to finish their medium-length transactions.

Table 7-1 describes the user classes implemented in z/VM.

*Table 7-1 User Classes and their description*

<b>User class</b>	<b>Description</b>
Class 0	Users who were added to the dispatch list with no delay in the eligible list, regardless of the length of their current transaction.
Class 1	Users who have just begun a transaction, and therefore are assumed to be currently processing short transactions.

User class	Description
Class 2	Users who did not complete their current transactions during their first dispatch list stay and therefore are assumed to be running medium-length transactions.
Class 3	Users who did not complete their current transactions during their second dispatch stay and therefore are assumed to be running long transactions.

If you have command privilege class E, you can issue the following CP command to view information about these classes of user:

```
INDICATE LOAD
```

In Example 7-1, the Q with a number (Qn) indicates users in the dispatch list, for example Q2; the E with a number (En) indicates users in the eligibility lists, for example E2. The n is the class of the user 0, 1, 2, or 3.

**Note:** Any values in the En fields normally indicates a performance problem (Probably a storage or paging constraint).

#### Example 7-1 INDicate LOAD command

```
ind load
AVGPROC-000% 04
XSTORE-000000/SEC MIGRATE-0000/SEC
MDC READS-000001/SEC WRITES-000000/SEC HIT RATIO-099%
PAGING-1/SEC STEAL-000%
Q0-00000(00000)                                DORMANT-00012
Q1-00000(00000)                                E1-00000(00000)
Q2-00000(00000) EXPAN-001 E2-00000(00000)
Q3-00000(00000) EXPAN-001 E3-00000(00000)

PROC 0000-000% CP      PROC 0001-000% CP
PROC 0002-000% CP      PROC 0003-000% CP

LIMITED-00000
```

CP READ VMLINUX6

## 7.1.2 CP monitoring commands

This section introduces basic z/VM commands. If you are familiar with z/OS, you will find references to the equivalent or similar commands of z/OS to help you

expand your existing knowledge of z/OS. If you are not familiar with z/OS, this section can help you understand the basic functionality available with z/VM.

## **CP commands**

Performance management in a z/VM system requires tools to collect and analyze data, and to control resource usage by virtual machines. These tools are provided by the Control Program (CP) by means of commands and monitoring functions.

The four CP command groups described in this section are:

- ▶ CP INDICATE
- ▶ CP QUERY
- ▶ CP MONITOR
- ▶ CP SET

We present these commands and their most commonly used parameters.

### **CP INDICATE**

The CP INDICATE commands give a snapshot of resource utilization. Because it is only a snapshot, however, commands must be issued several times and the results examined for changes.

Some of the commands have an EXPanded option, which will give additional detail. The INDICATE command can be used by system resource operators, system programmers, system analysts, and general users (privilege class B, C, E, and G users) although different classes of user will see different results for some commands.

**z/OS analogy:** The CP INDICATE command is similar to the SDSF command DISPLAY ACTIVE (or its abbreviation DA).

### ***CP INDICATE ACTIVE***

Use this command to display:

- ▶ The total number of users active in a specified time interval
- ▶ The number of users in the dispatch, eligible, and dormant lists that were active in a specified time interval

An example of this command is shown in Example 7-2 on page 325.

*Example 7-2 INDicate ACTIVE command*

---

**ind active**

0009 USERS, 0005 DISP, 0000 ELIG, 0004 DORM  
Ready; T=0.01/0.01 09:54:21

---

The command accepts the following operands:

- nnnnn* Identifies an integer number specifying the time interval. The valid time period is 0 to 9 hours, or 540 minutes, or 32400 seconds. The default is 60 seconds.
- SEC Identifies that *nnnnn* was specified in seconds. This is the default.
- MIN Identifies that *nnnnn* was specified in minutes.
- HRS Identifies that *nnnnn* was specified in hours.

**CP INDICATE I/O**

Use this command to identify the virtual machines currently in an I/O wait state and the real I/O device number that they are waiting on. This command can assist you in spotting a volume for which minidisk cache or CU cache were mistakenly turned off.

**CP INDICATE LOAD**

Use this command to display information about system resources. See Example 7-3. For a general user, CP displays a subset of that information. Note that the processor usage information shown by this command is actually a *smoothed* average over a period of time. Changes in system load can likely take several minutes to influence this number. This command is a good starting point to analyze system performance problems.

On z/OS, you use the command DISPLAY ACTIVE to display such information.

**Note:** For monitoring instantaneous processor load, use the Performance Tool Kit.

*Example 7-3 CP INDicate LOAD*

---

```
cp ind load
AVGPROC-000% 04
XSTORE-000000/SEC MIGRATE-0000/SEC
MDC READS-000001/SEC WRITES-000000/SEC HIT RATIO-100%
PAGING-0/SEC STEAL-000%
Q0-00001(00000)                                DORMANT-00010
Q1-00001(00000)                                E1-00000(00000)
Q2-00000(00000) EXPAN-001 E2-00000(00000)
Q3-00000(00000) EXPAN-001 E3-00000(00000)
```

```
PROC 0000-000% CP      PROC 0001-000% CP
PROC 0002-000% CP      PROC 0003-000% CP
```

```
LIMITED-00000
Ready; T=0.01/0.01 09:56:25
```

RUNNING VMLINUX6

---

### **CP INDICATE PAGING**

Use this command to display:

- ▶ A list of the virtual machines in page wait status
- ▶ Page residency data for all system users

**z/OS analogy:** This command corresponds to z/OS command D ASM.

### **CP INDICATE QUEUES**

Use this command to display, in order of their priority, current members of the dispatch and eligible lists. See Example 7-4. If users have a virtual multiprocessor, you might see more than one entry for a single user.

*Example 7-4 INDicate Queues command*

---

```
ind queues
MAINT      Q1 R00 00001400/00001357 LNXGUI  MP01 Q3 PS 00000000/00000000
LNXGUI     Q3 PS 00020637/00020623 LNKKEN  MP01 Q3 PS 00000000/00000000
LNKKEN     Q3 PS 00114857/00114843 LNXCER      Q3 PS 00108507/00108493
LNXCER     MP01 Q3 PS 00000000/00000000 TCPIP      Q0 PS 00003011/00002656
Ready; T=0.01/0.01 10:10:01
```

---

**z/OS analogy:** This command corresponds to z/OS command DISPLAY ACTIVE.

## **CP INDICATE SPACES**

Use this command to display information about a user's address space and paging usage, as shown in Example 7-5.

*Example 7-5 INDicate SPaces command*

---

### **ind spaces**

```
Spaceid=MAINT:BASE Owned size=123M PRIVATE
Pages: Main=1400 Xstore=0 Dasd=0 Locked=---
Private paging:
  Xstore: Reads=0          Writes=0          Migrates=0
  Dasd:   Reads=1          Writes=1
Shared paging:
  Xstore: Reads=0          Writes=0          Migrates=0
  Dasd:   Reads=0          Writes=0
Ready; T=0.01/0.01 10:12:58
```

---

This command corresponds to z/OS DISPLAY ACTIVE command.

## **CP QUERY**

The CP QUERY commands can display information about the system and users. We introduce several query commands that are useful when you investigate performance problems. If you have a z/OS background, you can benefit from z/OS hints related to z/VM commands.

### **CP QUERY ALLOC**

Use this command to display the number of cylinders or pages that are allocated, in use, and available for DASD volumes attached to the system. See Example 7-6 on page 328.

Use QUERY ALLOC PAGE for detailed information about paging space.

**Note:** Do not confuse this command with the z/OS command ALLOCATE. They are very different, despite the name similarity.

**z/OS analogy:** CP QUERY ALLOC command corresponds to z/OS command D ASM.

*Example 7-6 Query ALLOC command*

---

**q alloc**

```
DASD 1A20 LX6RES 3390 CKD-ECKD (UNITS IN CYLINDERS)
    TDISK TOTAL=00000000000 INUSE=00000000000 AVAIL=00000000000
    PAGE  TOTAL=00000000000 INUSE=00000000000 AVAIL=00000000000
    SPOOL TOTAL=00000000000 INUSE=00000000000 AVAIL=00000000000
    DRCT  TOTAL=00000000020 INUSE=00000000001 AVAIL=00000000019, ACTIVE
DASD 1A21 LX6SPL 3390 CKD-ECKD (UNITS IN CYLINDERS)
    TDISK TOTAL=00000000000 INUSE=00000000000 AVAIL=00000000000
    PAGE  TOTAL=00000000000 INUSE=00000000000 AVAIL=00000000000
    SPOOL TOTAL=00000003338 INUSE=00000000803 AVAIL=00000002535
    DRCT  TOTAL=00000000000 INUSE=00000000000 AVAIL=00000000000
DASD 1A22 LX6PAG 3390 CKD-ECKD (UNITS IN CYLINDERS)
    TDISK TOTAL=00000000000 INUSE=00000000000 AVAIL=00000000000
    PAGE  TOTAL=00000003338 INUSE=00000000000 AVAIL=00000003338
    SPOOL TOTAL=00000000000 INUSE=00000000000 AVAIL=00000000000
    DRCT  TOTAL=00000000000 INUSE=00000000000 AVAIL=00000000000
DASD 1A23 LX6W01 3390 CKD-ECKD (UNITS IN CYLINDERS)
    TDISK TOTAL=00000000000 INUSE=00000000000 AVAIL=00000000000
    PAGE  TOTAL=00000000000 INUSE=00000000000 AVAIL=00000000000
    SPOOL TOTAL=00000000000 INUSE=00000000000 AVAIL=00000000000
    DRCT  TOTAL=00000000000 INUSE=00000000000 AVAIL=00000000000
DASD 1A24 LX6W02 3390 CKD-ECKD (UNITS IN CYLINDERS)
    TDISK TOTAL=00000000000 INUSE=00000000000 AVAIL=00000000000
    PAGE  TOTAL=00000000000 INUSE=00000000000 AVAIL=00000000000
    SPOOL TOTAL=00000000000 INUSE=00000000000 AVAIL=00000000000
    DRCT  TOTAL=00000000000 INUSE=00000000000 AVAIL=00000000000
.....
IPL NUCLEUS ACTIVE ON VOLUME LX6RES
Ready; T=0.01/0.01 10:16:51
```

---

***CP QUERY CHPIDS***

Use this command to display all of the machine's 256 channel paths and their physical status. I/O performance problems can occur if CHPIDs are offline or not available. See Example 7-7 on page 329.



*Example 7-7 Query CHPIDS command*

---

```
q chpids
  0 1 2 3 4 5 6 7 8 9 A B C D E F
0x + + + + + + + + + + + + + +
1x + + + + + + + + + + + + + +
2x . . . . . . . . . . . . . .
3x - + . . . . . . . . + + + + . .
4x + + + + + + + + + + + + + +
5x + + + + + + + + + + + + + +
6x + + + + + + + + + + + + + +
7x + + + + + + + + + + + + . . .
8x . . . . . . . . . . . . . .
9x . . . . . . . . . . . . . .
Ax . . . + . . . + . . . . . . . .
Bx . . . . . . . . . . . . . .
Cx . . . . . . . . . . . . . .
Dx . . . . . . . . . . . . . .
Ex . . . . . . . . . . . . . .
Fx + + + + + + + + + + + + + +
```

+ Available  
- Offline  
. Not configured  
Ready; T=0.01/0.01 10:18:45

---

**z/OS analogy:** This command acts like the z/OS **D M=CHP** command. Both commands display the machine's channel paths and their physical status.

### **CP QUERY CPLOAD**

Use this command to display information regarding the last CP IPL. The information displayed includes the location of the CP module that was last used, the location of the parm disk, and how CP was started.

*Example 7-8 Query CPLOAD command*

---

```
q cpload
Module CPLOAD was loaded from minidisk on volume LX6RES at cylinder 39.
Parm disk number 1 is on volume LX6RES, cylinders 39 through 158.
Last start was a system IPL.
Ready; T=0.01/0.01 10:21:13
```

---

**z/OS analogy:** This command is similar to the **D IPLINFO** command on z/OS.

## **CP QUERY CPOWNERD**

Use this command to display the list of CP-owned DASD volumes. If paging or spooling problems occur, this can be checked to ensure that all required volumes are available. See Example 7-9.

*Example 7-9 QUERY CPOWNERD command and sample output*

---

### **q cpowered**

Slot	Vol-ID	Rdev	Type	Status
1	LX6RES	1A20	Own	Online and attached
2	LX6SPL	1A21	Own	Online and attached
3	LX6PAG	1A22	Own	Online and attached
4	LX6W01	1A23	Own	Online and attached
5	LX6W02	1A24	Own	Online and attached
6	DK8226	8226	Own	Online and attached
7	DK8227	8227	Own	Online and attached
8	DK8228	8228	Own	Online and attached
9	-----	----	----	Reserved
10	-----	----	----	Reserved

---

## **CP QUERY FRAMES**

Use this command to display the status of host real storage. You might have to do this if users are in the eligible list when you have to check storage utilization.

*Example 7-10 Query FRAMES command*

---

### **cp q frames**

All Frames:

Configured=1048575 Real=1048575 Usable=1048575 Offline=0  
Pageable=1026485 NotInitialized=0 GlobalClearedAvail=128  
LocalClearedAvail=128 LocalUnclearedAvail=124

Frames < 2G:

GlobalUnclearedAvail=454261 Pageable=521003 LogicalFreeStorage=56  
RealFreeStorage=4 LockedRS=348 LockedCmd=0  
MinidiskCache=9339 Nucleus/Prefix=2430 Trace=325 Other=122

Frames > 2G:

GlobalUnclearedAvail=436453 Pageable=505482 LogicalFreeStorage=1194  
RealFreeStorage=19 LockedRS=57 LockedCmd=0  
MinidiskCache=13138 Other=17536

---

**z/OS analogy:** This command is similar to the z/OS **D - M=STOR** command.

## CP QUERY MAXUSERS

Use this command to display the maximum number of logged-on users allowed. If users cannot log on, this might be a good command to execute.

**z/OS analogy:** To display the number of maximum users in a z/OS environment, browse the member IEASYSxx of your SYS1.PARMLIB concatenation.

## CP QUERY MDC

Use this command from a class B user to query minidisk cache (MDC) settings for the entire system, for a real device, an active minidisk, or a minidisk defined in the directory. See Example 7-11. This command is useful for investigating I/O problems.

*Example 7-11 Query MDC command*

---

```
q mdc
Minidisk cache ON for system
Storage MDC min=0M max=128M, usage=3%, bias=1.00
Xstore MDC min=0M max=0M, usage=0%, bias=1.00
Ready; T=0.01/0.01 10:23:24
```

---

## CP QUERY NAMES

Use this command to display:

- ▶ A list of all logged-on users
- ▶ The real or logical device number of the display that each user is connected

See Example 7-12.

*Example 7-12 Query Names command*

---

```
q n
LNXCER - DSC , LNXGUI - DSC , LNKKEN - DSC , COSTA -L0004
FTPSERVE - DSC , TCPIP - DSC , DTCVSW2 - DSC , DTCVSW1 - DSC
VMSERVR - DSC , VMSERVU - DSC , VMSERVS - DSC , OPERSYMP - DSC
DISKACNT - DSC , EREP - DSC , OPERATOR - DSC , MAINT -L0003
VSM - TCPIP
Ready; T=0.01/0.01 10:26:04
```

---

**z/OS analogy:** On z/OS systems, you can display similar information by running the SDSF **Display Active** command.

### **CP QUERY QIOASSIST**

Use this command to determine the current status of the queue-I/O assist for a virtual machine, as shown in Example 7-13. This command is useful for investigating I/O or networking problems.

*Example 7-13 Query QIOASSIST command*

---

```
q qioassist
ALL USERS SET - ON

USER      SETTING  STATUS
MAINT     ON          INACTIVE
Ready; T=0.01/0.01 10:28:40
```

---

### **CP QUERY QUICKDSP**

Use this command to display the QUICKDSP attribute for a user. See Example 7-14 for sample output.

*Example 7-14 QUICKDSP command*

---

```
cp query quickdsp maint
USER MAINT : QUICKDSP = OFF
```

---

### **CP QUERY RESERVED**

Use this command to display the number of reserved real storage frames, and to reserve pages of storage for a user. See Example 7-15.

*Example 7-15 Query RESERVED command*

---

```
q res
MAINT   RSV=00000010 ACT=00000010
LNXGUI  RSV=00000020 ACT=00000020
REQUESTED FRAME TOTAL=00000030; ACTUAL FRAME TOTAL=00000030
Ready; T=0.01/0.01 10:57:15
```

---

The CP QUERY RESERVED command is useful when tuning users in a storage-constrained system.

### **CP QUERY SRM**

Use this command to display system-wide parameters used by the scheduler to set the priority of system resource access. SRM is System Resource Manager. See Example 7-16 on page 333.

**Important:** Use this command carefully and monitor its usage because eligible lists can occur if not used properly.

Note that the CP SET SRM command is useful if you want to control a user's use of resources, depending on the class of user.

*Example 7-16 Query SRM command*

---

```
q srm
IABIAS : INTENSITY=90%; DURATION=2
LDUBUF : Q1=100% Q2=75% Q3=60%
STORBUF: Q1=300% Q2=250% Q3=200%
DSPBUF : Q1=32767 Q2=32767 Q3=32767
DISPATCHING MINOR TIMESLICE = 5 MS
MAXSS : LIMIT=9999%
..... : PAGES=999999
XSTORE : 0%
Ready; T=0.01/0.01 12:27:28
```

---

**z/OS analogy:** In z/OS, you can set SRM parameters, but you cannot view these parameters in a direct way.

### **CP QUERY STOR**

Use this command to display the size of real storage. See Example 7-17.

*Example 7-17 Query STORage command*

---

```
q stor
STORAGE = 4G
Ready; T=0.01/0.01 12:35:16
```

---

**z/OS analogy:** In z/OS, you can run the command **D M=STOR** to display the size of the real storage.

### **CP QUERY SYSTEM**

Use this command to display current user access to a system DASD volume.

**z/OS analogy:** In z/OS, you should know the device number before issuing the following z/OS command:

```
D U,, ALLOC, devnum.nnnn
```

### **CP QUERY XSTOR**

Use QUERY XSTORAGE or QUERY XSTORE to display the assignment of real expanded storage, or to investigate response time or paging problems. See Example 7-18 on page 334.

### Example 7-18 Query XSTORage

---

#### **q xstor**

```
XSTORE= 2048M online= 2048M
XSTORE= 2048M userid= SYSTEM usage= 0% retained= 0M pending= 0M
XSTORE MDC min=0M, max=0M, usage=0%
XSTORE= 2048M userid= (none) max. attach= 2048M
Ready; T=0.01/0.01 12:35:19
```

---

## **CP MONITOR**

The CP MONITOR command collects system performance data that can be made available to an external data reduction program for analysis. Statistics related to system operation or contention for major system resources can be generated. These resources include processors, storage, I/O devices, and the paging subsystem. You can control the amount and nature of the data collected.

In general, the monitoring process has the following flow:

1. The user issues the privileged CP MONITOR command to control monitoring. This includes the type, amount, and nature of data to be collected.
2. The monitor collects performance data and stores monitor records in a saved segment.
3. A CMS application program connects to the CP MONITOR System Service to establish a data link with CP.
4. The application retrieves and processes monitor records from the saved segment.

## **CP SET**

The CP SET commands can change the performance characteristics of the entire system or of a single user.

### ***CP SET MAXUSERS***

Use this command to control the number of allowed users to log on. If the CPU is constrained, you can use this command to limit the number of users.

**z/OS analogy:** In z/OS, to set the number of users, you would set the parameters in the member IEASYSxx in the ParmLib.

### ***CP SET MDC***

Use this command from a class B user to perform the following tasks:

- ▶ Change minidisk cache settings for the entire system, for a real device, or for an active minidisk.

- ▶ Purge the cache of data from a real device or an active minidisk.
- ▶ Change a user's ability to insert data into the cache.

This command can be useful if you do not have much minidisk activity and you want to release more storage.

### ***CP SET QIOASSIST***

Use this command to control the queue-I/O assist (QDIO performance assist for V=V guests<sup>1</sup>) for a virtual machine. This interpretive-execution assist applies to devices that use the Queued Direct I/O (QDIO) architecture, HiperSockets devices, and FCP devices.

### ***CP SET QUICKDSP***

Use this command to assign or unassign a user's immediate access to system resources.

**z/OS analogy:** In z/OS, you would use WLM to perform similar tasks.

### ***CP SET RESERVED***

Use this command to establish the number of real storage frames that are available to a specific virtual machine.

This command can be useful when you are trying to tune specific guests in a storage-constrained environment.

### ***CP SET SHARE***

Use this command to change the system-resource access priority for users. This is a complex command that can have profound effect on system and user resource usage. Use it with care.

### ***CP SET SRM***

Use this command to change system parameters. These parameters define the size of the time slice and the access to resources for different user classes as seen by the scheduler. This is a complex command. Make sure you clearly understand the command's effects before you use it.

**Note:** For more information about SET SRM, refer to the *z/VM: CP Commands and Utilities Reference*, SC24-6081, which can be found at:

<http://publib.boulder.ibm.com/infocenter/zvm/v5r3/topic/com.ibm.zvm.v53.hcpb7/hcse4b21.htm>

<sup>1</sup> Guest Type V=V is a z/VM measurement with Linux defined as virtual equals virtual machine.

### ***CP SET THROTTLE***

Use this command to control the number of I/O operations that a guest operating system can initiate to a specific real device. This prevents a guest from interfering with, or dominating, I/O resources.

## **7.2 Tuning basics**

System z processors have evolved over the years to be highly robust and reliable. This section introduces general tuning concepts and explores their practical implications on z/VM.

### **7.2.1 System tuning approach**

Performance analysis and tuning is a multi-step process. Regardless of which tools you choose, the best methodology for analyzing the performance of a system is to start from the outside and work your way in to the small tuning details. Start by gathering data about the overall health of systems hardware and processes. How busy is the processor during the peak periods of each day? What happens to I/O response times during those peaks? Do they remain fairly consistent, or do they elongate? Does the system become memory-constrained every day, causing page waits? Can current system resources provide user response times that meet service level agreements? Following a good performance analysis process can help you answer those questions.

Knowing what tuning tools are available and the types of information that they provide is important. Equally important is knowing when to use those tools and what to look for. Waiting until the telephone rings with user complaints is too late to start running tools and collecting data. How will you know what is normal for your environment and what is problematic unless you check the system activity and resource usage regularly? Conducting regular health checks on a system also gives you usage and performance information that can be helpful for capacity planning purposes.

### **7.2.2 Where tuning can help**

Even when the different workloads add up to less than the total amount of resources available, you might find that you are still unable to run the workload with good performance. The reason might be that the system lacks a specific resource. In such a situation, proper tuning can make a difference. Before tuning the system and workload, you should understand what resource is the limiting



factor in your configuration. Tuning changes tend to fall into one of these categories:

- ▶ Use fewer constrained resources.

One of the benefits of running Linux systems under z/VM is the ability to share and to overcommit hardware resources. The amount of memory that Linux thinks it owns is called virtual memory. The sum of the amounts of virtual memory allocated to each Linux guest can be many times the amount of real memory available on the processor. z/VM efficiently manages memory for Linux guests. With a system that is really memory constrained, one option might be to reduce overall z/VM memory usage by reducing the virtual machine size of Linux guests.

- ▶ Obtain a larger share of a constrained resource.

Users can easily increase the virtual memory size for Linux guests, because it is a quick change to the guest definition under z/VM. However, needlessly increasing virtual memory allocations can cause excessive paging (also known as *thrashing*) for the entire system. If a system that is truly memory-constrained, and where Linux virtual memory sizes have been assigned judiciously, consider reserving some memory pages for one particular Linux virtual machine, at the expense of all others. This can be done with a z/VM command (CP SET RESERVED).

- ▶ Increase total available resources.

The most obvious approach to solving memory issues is to buy more hardware. The cost of memory has declined over the years, so that might be a good option. However, additional resources can be made available by stopping unneeded utility services in the Linux systems. Be aware that tuning does not increase the total amount of system resources. It simply allows those resources to be used more effectively for critical workloads.

### 7.2.3 Where tuning does not help

Understand this: you cannot run more work than you can fit in the machine. If your System z machine has two CPUs and the workload you want to run consists of three Linux virtual machines running WebSphere, where each of them runs a CPU for 100% all day, then it will not fit. No amount of z/VM tuning will make it fit, but there might be performance issues in the applications themselves to make the workload use less than 100% all day.

When a System z machine has four CPUs and the workload consists of three Linux virtual machines that each use a CPU for 100% all day, there is little to tune. In this case, z/VM has sufficient resources to give each Linux virtual machine what it requires (though you might want to look into changes to the configuration that allow you to use all four CPUs and make things run faster).

## 7.3 Performance and Monitoring tools for z/VM

The use of tools to monitor and enhance performance is common. Performance monitoring tools provides more functionality and reports on your system z/VM status.

In this section, we introduce several performance monitoring tools. For more details, see the IBM Redbooks publication *Linux on IBM System z: Performance Measurement and Tuning*, SG24-6926.

### 7.3.1 IBM Performance Toolkit for VM

The IBM Performance Toolkit for VM is an enhanced real-time performance monitor and full-screen operator that allows system programmers to monitor system performance and to analyze bottlenecks. The toolkit can help system programmers make more efficient use of system resources, increase system productivity, and improve user satisfaction. In addition to analyzing z/VM performance data, the Performance Toolkit for VM can process Linux performance data obtained from the IBM Resource Management Facility (RMF) and the Linux performance gatherer, rmfpms. Several other functions provided by the Performance Toolkit for z/VM include:

- ▶ Operation of the system operator console in full-screen mode
- ▶ Management of multiple z/VM systems (local or remote)
- ▶ Post-processing of performance toolkit for VM monitor data captured by the MONWRITE utility
- ▶ Viewing of performance monitor data using either Web browsers or PC-based
- ▶ 3270 emulator graphics
- ▶ TCP/IP performance reporting

Figure 7-2 on page 339 depicts a typical Performance Toolkit window.

**Note:** For more information about Performance Toolkit, refer to *Linux on IBM eServer zSeries and S/390: Performance Toolkit for VM*, SG24-6059

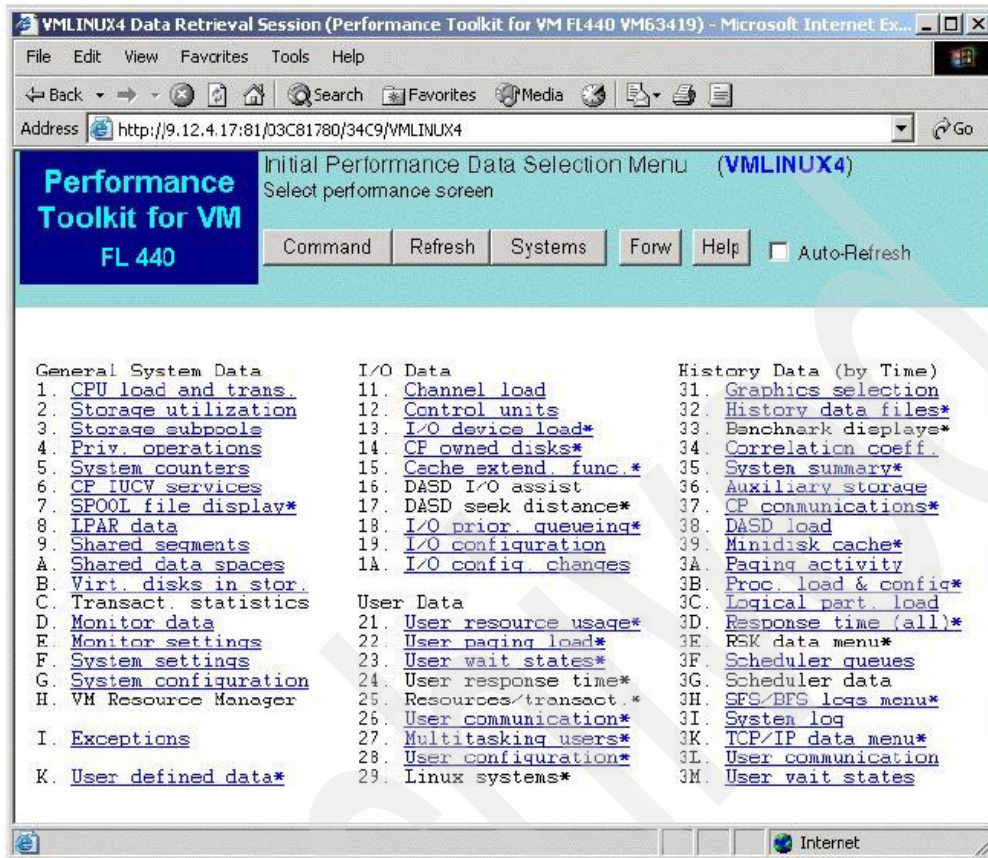

Figure 7-2 Performance toolkit

### 7.3.2 Tivoli OMEGAMON for z/VM and Linux

OMEGAMON® is a real-time software performance monitor for the VM (Virtual Machine) operating system. It runs under the Conversational Monitor System (CMS) operating system. OMEGAMON warns you of exceptional conditions automatically, and also displays the status of VM internal operations and resources in real time.

All OMEGAMON features and facilities are designed for the concept of a logical tuning approach to improve the performance of your system. The logical tuning approach consists of the following steps:

1. Defining standards for VM performance at your installation.

2. Monitoring your system to measure actual performance against these standards.
3. Identifying the cause of performance problems.
4. Initiating action to correct performance problems.

Figure 7-3 shows a portion of the Tivoli® OMEGAMON guest performance view.

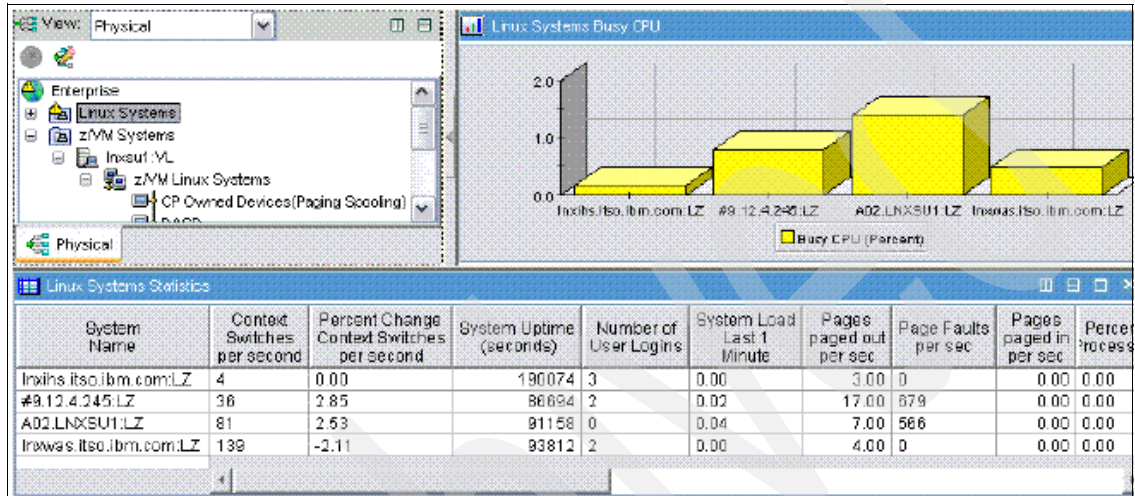

Figure 7-3 Tivoli OMEGAMON guest performance view (partial view only)

**Note:** For additional information about IBM Tivoli OMEGAMON, refer to:

- ▶ Linux on IBM System z: Performance Measurement and Tuning
- ▶ The following Web address:

<http://www-306.ibm.com/software/sysmgmt/products/support/IBMTivoliOMEGAMONonzVMLinux.html>

### 7.3.3 IBM Tivoli Performance Modeler

IBM Tivoli Performance Modeler for z/OS V2.3 is a PC-based performance modeling and capacity planning tool that runs on Microsoft Windows. It can be as portable as your PC or mobile computer. IBM Tivoli Performance Modeler for z/OS V2.3 is designed for system management on the IBM eServer™ zSeries and S/390.

With growing operating system complexity and the huge effect of responding to workload changes, basic central processor unit (CPU) usage is generally no

longer sufficient information for performing capacity planning. IBM Tivoli Performance Modeler for z/OS V2.3 can be used to model the effect of changing the following items:

- ▶ Number and speed of CPUs
- ▶ Disk I/O response times
- ▶ Paging rates (auxiliary and expanded memory paging)
- ▶ Logical partition (LPAR) definitions and parameter changes

The Tivoli Performance Modeler takes input from z/OS images, including system and application performance data, as a basis for the modeling program. The user can then make changes to the type of processor and modify the workload configuration to create a new model. The modeler then creates a series of graphs to depict the modeled workload.

### **7.3.4 IBM z/VM Planner for Linux guests on IBM System z Processors**

The z/VM Planner for Linux Guests on IBM System z Processors (z/VM Planner) is a PC-based productivity tool that runs under Microsoft Windows. (IBM employees and authorized IBM Business Partners can use the tool with their customers.) It is designed to provide capacity planning insight for IBM mainframe processors running various Linux workload environments as guests under VM. Input consists primarily of z/VM guest definitions and capacity requirements for each intended Linux guest. The total guest capacity requirement is calculated based on the guest definitions and, because all guests probably do not have peak utilization at the same time, a user-specified complementary peak percentage is used to calculate the true combined capacity requirements of the z/VM guests being sized. The tool also models z/VM processor requirements when merging new guests into existing VM images. The resulting guest capacity requirement is combined with that of VM to support the entire complement of guests.

The z/VM-Planner produces several graphs that depict the modeled system. The graphs illustrate the size of processor needed to support the modeled workload, the percent of that processor used by each application in the workload, and the estimated minimum and maximum processing capacity necessary for the workload. Figure 7-4 on page 342 represents the minimum and maximum capacity requirements for a modeled workload with five Linux guests running a mixture of Web applications, databases, and file servers.

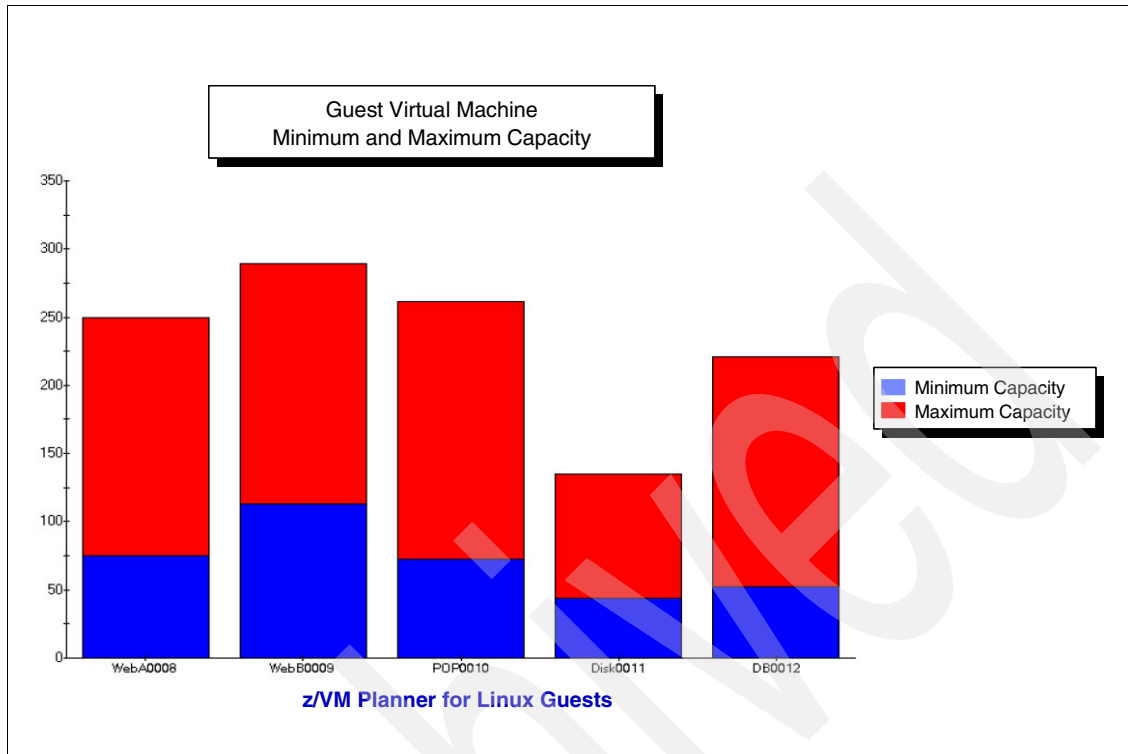

Figure 7-4 IBM z/VM Planner for Linux Guests

### 7.3.5 Tivoli Workload Scheduling Suite

The Tivoli Workload Scheduling Suite is the state-of-the-art production workload manager, designed to help you meet your present and future data processing challenges. Its scope encompasses your entire enterprise information system, including heterogeneous environments.

The Tivoli Workload Scheduling Suite simplifies systems management across heterogeneous environments by integrating systems management functions. The three main components to the suite are:

- ▶ Tivoli Workload Scheduler for z/OS: The scheduler in z/OS environments
- ▶ Tivoli Workload Scheduler: The scheduler in distributed environments
- ▶ Tivoli Job Scheduling Console: The common user interface for both Tivoli Workload Scheduler for z/OS and Tivoli Workload Scheduler.

**Note:** For more information about Tivoli Workload Scheduling Suite, refer to:  
<http://publib.boulder.ibm.com/infocenter/tivihelp/v3r1/index.jsp?toc=/com.ibm.tivoli.itws.doc/toc.xml>

## Sizing considerations for Linux Guests

The Linux memory model has profound implications for Linux guests running under z/VM:

- ▶ z/VM memory is a shared resource.  
Although aggressive caching reduces the likelihood of disk I/O in favor of memory access, the cost of caching must be considered. Cached pages in a Linux guest reduce the number of z/VM pages available to other z/VM guests.
- ▶ A larger virtual memory address space requires more Linux kernel memory for Linux memory management.  
When sizing the memory requirements for a Linux guest, choose the smallest memory footprint that has a minimal effect on the performance of that guest. To reduce the penalty of occasional swapping that might occur in a smaller virtual machine, use fast swap devices.

Although a 512 MB server does not require all that memory, it will eventually appear to use it all. Its memory cost is four times that of the 128 MB server.

**Note:** Additional information can be found in the Performance Report on the z/VM Web site at:

<http://www.ibm.com/servers/eserver/zseries/zvm/perf/docs/>

Additional z/VM performance tips are available on the z/VM Web site at:

<http://www.ibm.com/servers/eserver/zseries/zvm/perf/tips/>

### 7.3.6 Tuning memory for z/VM Linux guests

Storage tuning is very useful in virtualized environments, especially when the hypervisor can overcommit resources. z/VM is the most functionally capable software hypervisor operating system in existence, and fine tuning in all of the key resource areas, such as memory, is recommended for best overall system performance.

To minimize the system overhead and reduce its foot print, reducing operational machine size is often helpful. There are many ways by which the servers' memory foot print can be reduced. A common and intuitive approach is to kill

unnecessary processes. You can also tune z/VM memory usage by reducing the virtual machine size to the smallest possible size. The optimal smallest size might require a number of trials and experimentation.

**Note:** For more information about sizing of Linux virtual memory, refer to *Linux on IBM System z: Performance Measurement and Tuning*, SG24-6926.

Dividing larger servers into smaller, more specialized servers can prove to be effective. Smaller servers can be tailored to perform specific operations. However, this is at a cost because each server requires some memory to run its own operating system.

Using a VDISK with the DIAGNOSE access method as a swap device reduces the performance penalty of swapping. This recommendation is applicable only if you have a large amount of the real memory available on System z. Using virtual disk for swap, reduces the I/O generated by swap on real devices, but at the same time increases the total amount of storage used. This tip is useful when a high-paging rate comes from Linux and z/VM. In this situation, it is possible to experience effects of double-paging (z/VM pages out guest storage already swapped out by Linux) and the use of VDISK as a swap device can help to reduce it.

Use the DIAGNOSE driver for the DASD and MDC record cache to reduce infrastructure storage costs. Using a record-level minidisk cache reduces the amount of storage required for MDC. This requires the DIAGNOSE driver.

**Note:** For more information refer to *IBM Linux on System z: Device Drivers, Features, and Commands*, SC33-8289.

If you are running Linux under z/VM you can exploit the Cooperative Memory Management 1 (CMM1) functions, providing a better storage allocation between guests.

Another way to reduce memory usage is to use shared kernel or execute-in-place technology. These new technologies can be used to reduce the total amount of storage needed to manage Linux instances.

### 7.3.7 Execute-in-place technology

You can minimize memory requirements and improve your performance of virtual Linux using discontinuous saved segments (DCSS). In a virtualized environment, Linux images might need the same data at the same moment. This means that the same data could get loaded into memory several times. A major part of



memory required by Linux is used for binary application files and for shared library files. This technology helps you provide a way to share memory for some application using a DCSS managed by z/VM.

Considerations for data sharing are as follows:

- ▶ Application files can only be shared by Linux instances that use the same version of an application.
- ▶ Shared data must be read-only.
- ▶ Applications and libraries that are frequently used by numerous Linux instances are good candidates.

DCSS can be defined at the address above the Linux guest storage or in a storage gap. Usually, using DCSS in a storage gap is the preferred placement for a 64-bit Linux guest. Linux can access a DCSS through the execute-in-place file system (xip2).

Linux loads shared library and application files through the `mmap()` operation, which maps the contents of a file into the application's address space. The xipl file system performs this operation by mapping the contents of the DCSS into the application's address space while other file systems use a page cache. This feature is called *execute-in-place* because the file contents are not physically copied to a different memory location.

With execute-in-place technology, Linux can:

- ▶ Access files and libraries without I/O operations (which increases overall performance).
- ▶ Run an application directly in a shared memory segment (which saves memory).

## 7.4 Monitoring your Linux guests

Performance monitoring of Linux guests involves elaborate tasks of checking both your system z performance, as well as the guest operating systems. In the previous sections, we introduced scheduling concepts, and important monitoring commands on system z/VM. This section addresses the Linux guest monitoring tasks.

## 7.4.1 The vmstat command

The **vmstat** command displays current statistics for processes, usage of real and virtual memory, paging, block I/O, and CPU. Refer to Example 7-19, for the following information:

- ▶ The **procs** section shows the number of running processes and number of blocked processes.
- ▶ The **memory** section shows memory being swapped out, free memory, the amount of buffer containing inodes and file metadata, and cached memory for files being read from disk.
- ▶ The **swap** section lists swaps in and swaps out.
- ▶ The **io (I/O)** section reports the number (in kilobytes) of blocks read in and written out.
- ▶ The **system** **in** and **cs** represent interrupts and context switches per second.
- ▶ The **cpu** section headers of **us**, **sy**, **id**, and **wa** represent percentage of CPU time count on users, system, idle, I/O wait, and steal, respectively. The **vmstat** command is useful in identifying memory shortages and I/O wait issues, in addition to situations where virtual CPUs are not backed up by physical CPUs.

Example 7-19 lists system information after running **vmstat** with ten updates, five seconds apart, using the command:

```
vmstat 5 10
```

*Example 7-19 .vmstat command*

---

procs			memory				swap		io		system		cpu		
r	b	w	swpd	free	buff	cache	si	so	bi	bo	in	cs	us	sy	id
0	0	0	29232	116972	4524	244900	0	0	0	0	0	0	0	0	0
0	0	0	29232	116972	4524	244900	0	0	0	0	2560	6	0	1	99
0	0	0	29232	116972	4524	244900	0	0	0	0	2574	10	0	2	98

---

## 7.4.2 The pstree command

The **pstree** command shows the dependencies and relationships of applications. It is similar to the **ps -eafx** command. Example 7-20 show the **pstree** command.

*Example 7-20 pstree command*

---

```
user@pserver1:~> pstree
```

```
  ...  
  |-4*[nfsd]
```

```

|-nmbd
|-nscd---nscd---5*[nscd]
|-ntpd
|-portmap
|-rpc.mountd
|-rpc.statd
|-safe_mysqld---mysqld---mysqld---mysqld
|-2*[screen---bash]
|-scsi_ah_0
|-scsi_ah_1
|-smbd
|-sshd+-2*[sshd---sshd---bash---vim]
      | -sshd---sshd---bash---su---bash
      `--sshd---sshd---bash---pstree
~syslogd

```

---

### 7.4.3 The top Command

The **top** command prints out system data per process. It shows an overview of the currently running system processes. The **top** command itself consumes CPU resources. See Example 7-21

*Example 7-21 top command*

```

[user@pserver1]$ top
1:40pm up 3:17, 11 users, load average: 0.00, 0.02, 0.03
134 processes: 127 sleeping, 6 running, 1 zombie, 0 stopped
CPU states: 1.9% user, 1.7% system, 0.0% nice, 96.2% idle
Mem: 1030464K av, 675028K used, 355436K free, 0K shrd, 156256K buff
Swap: 1663160K av, 0K used, 1663160K free, 296068K cached

```

PID	USER	PRI	NI	SIZE	RSS	SHARE	STAT	%CPU	%MEM	TIME	COMMAND
1746	wolf				15	0	54772	14M	11600	R	1.1 1.4 0:00 kdeinit
6147	wolf				15	0	1080 1080	840	R	0.9 0.1 0:00 topPrint	

the output

of the 'top' command to a file:

```
top d 4 b i > out
```

d refresh rate in seconds

b batch

i only active processes

## 7.4.4 System status (sysstat) tool

This package consists of several Linux tools to collect system data. The sysstat package is a widely used Linux standard tool. It is included in your distribution (RHEL 5 or SLES 10) or can be downloaded from the Web at:

<http://pagesperso-orange.fr/sebastien.godard/>

If you install the source package, you have to compile it on Linux on System z to use it. The sysstat package consists of the following components:

<b>sadc data gatherer</b>	Stores data in binary file
<b>sar reporting tool</b>	Reads binary file created with sadc and converts it to readable output
<b>mpstat</b>	Is for processor utilization
<b>iostat</b>	Is for I/O utilization

The sar reporting tool prints the following information:

- ▶ Process creation
- ▶ Context switching
- ▶ All/single CPU utilization
- ▶ Network utilization
- ▶ Disk statistics

For a more detailed description of sysstat, see:

[http://www.ibm.com/developerworks/linux/linux390/perf/tuning\\_how\\_tools.html#sysstat](http://www.ibm.com/developerworks/linux/linux390/perf/tuning_how_tools.html#sysstat)

## 7.4.5 The OProfile tool

OProfile is an open source profiler for Linux systems. It offers profiling of all running code on a Linux system, including the kernel, shared libraries, application binaries, and so on, and provides a variety of statistics at a low overhead (varying from 1–8%) depending on the workload. It is released under the GNU GPL. OProfile consists of a kernel driver, a daemon for collecting sample data, and tools for report generation.

OProfile generally supports Linux kernel 2.2, 2.4, 2.6, and later.

**Note:** If you are running:

- ▶ SUSE Linux, the kernel level must be at least kernel-s390(x)-2.6.5-7.191, which starts from SLES9 SP2.
- ▶ Red Hat Linux, the kernel level must be at least kernel-2.6.9-22.EL, which is RHEL4 U2.
- ▶ Linux on System z, OProfile only supports kernel 2.6 or later.

OProfile uses a CPU's performance counters to count events for all of the running code, and aggregates the information into profiles for each binary image. However, System z hardware currently does not have support for this kind of hardware performance counters used by OProfile, so the timer interrupt is used instead.

Example 7-22 illustrates a typical usage of OProfile on a Linux guest running on z/VM. To use the OProfile tool, turn on the timer by using command **sysctl**. After all profiling is done, turn the timer off. To set up the environment, use the **opcontrol** command to tell OProfile the location of the **vmlinux** file corresponding to the running kernel. Then, it is ready to collect the profile data. After the test and tool shutdown, the profiling report can be generated.

*Example 7-22 Oprofile tool*

---

```
sysctl -w kernel.hz_timer=1 1
gunzip /boot/vmlinux-2.6.5-7.201-s390x.gz 2
opcontrol --vmlinux=/boot/vmlinux-2.6.5-7.201-s390x 3
opcontrol --start 4
26 Linux on IBM System z: Performance Measurement and Tuning
<DO THE TEST>
opcontrol --shutdown 5
opreport 6
```

---

Note the following points:

- 1** The command to turn on the timer (`timer=1`). When the profiling is finished, turn off the timer (`timer=0`).
- 2** Unzip the `vmlinux` file if none exists.
- 3** Specify the `vmlinux` file for the running kernel.
- 4** Start the OProfile daemon, and begin profiling.
- 5** Stop the OProfile daemon, and stop profiling.
- 6** Provide product symbol or binary image summaries.

In Figure 7-5, the CPU information is not correctly displayed. The System z hardware does not support the CPU performance counters required by OProfile yet, however the output does contain valuable information.

```

CPU: CPU with timer interrupt, speed 0 MHz (estimated)
Profiling through timer interrupt
vma          samples %      app name      symbol name
80002840     5862    34.8970  mcf_base.z_Linux  price_out_impl
800012c8     5221    31.0811  mcf_base.z_Linux  refresh_potential
80003cb4     4398    26.1817  mcf_base.z_Linux  primal_bea_mpp
80003b60     408     2.4289   mcf_base.z_Linux  sort_basket
0001a67c     345     2.0538   vmlinux           default_idle
800013d8     138     0.8215   mcf_base.z_Linux  flow_cost
800033bc     98      0.5834   mcf_base.z_Linux  update_tree
800020f8     88      0.5239   mcf_base.z_Linux  dual_feasible
800036a4     72      0.4286   mcf_base.z_Linux  primal_iminus
8000323c     40      0.2381   mcf_base.z_Linux  write_circulations
80002720     24      0.1429   mcf_base.z_Linux  insert_new_arc

```

Figure 7-5 OProfile output

The output includes:

- vma**           The virtual memory area (vma) is a contiguous area of virtual address space. These areas are created during the life of the process when the program attempts to memory-map a file, links to a shared memory segment, or allocates heap space.
- samples**       The number of samples for the symbol
- %**             The percentage of samples for this symbol relative to the overall samples for the executable
- app name**      The application name to which the symbol belongs
- symbol name**   The name of the symbol that was executed

From the report of OProfile, we can analyze the performance of a target module and adjust tuning accordingly. For example, in Figure 7-5, modules of the application `mcf_bas.z_Linux` consume most of the CPU time. To improve the performance of this application, more attention should be paid to these modules than the others.

**Note:** For details and documentation about the OProfile commands, see: <http://oprofile.sourceforge.net/docs/>

# System events and logs, backup and recovery

Linux on System z is a reliable environment to run applications. However, error situations can still occur. For instance, you might encounter:

- ▶ Software errors: abnormal program termination, invalid input data
- ▶ Operating system errors: at the Linux or z/VM level
- ▶ Hardware errors: LPAR, system or disk subsystem failure

This chapter provides an overview of several tools available in z/VM and Linux to collect and analyze system events, and to create backups and restore them in case of an unrecoverable failure.

## Objectives

After completing this chapter, you should be able to:

- ▶ List the tools available for system events and errors logging
- ▶ List the tools available for errors analysis
- ▶ Discuss the various options considered for backing up and restoring data

## 8.1 z/VM and Linux error handling

This section provides an overview of how errors are handled in z/VM and Linux, and details about several error codes.

### 8.1.1 z/VM default error handling

Each z/VM feature, module, or facility, is responsible for handling the *user-related* errors that occur when a command is issued. These errors can be caused by, but are not limited to, incorrect configuration, incorrect invocation of a command, irrelevant input data. When such an error occurs, the function that fails informs the user by issuing an error code and message.

For instance, CP issues the message shown in Example 8-1 when a user tried to log on to a virtual machine that is not defined in z/VM.

*Example 8-1 Error message when logging on to an undefined virtual machine*

---

```
L LASMAYOU LASMAYOU
HCPLGA053E LASMAYOU not in CP directory
```

Enter one of the following commands:

```
LOGON userid          (Example: LOGON VMUSER1)
DIAL userid           (Example: DIAL VMUSER2)
MSG userid message   (Example: MSG VMUSER2 GOOD MORNING)
LOGOFF
```

---

For more details about z/VM error codes and messages, refer to section 8.1.2, “z/VM error codes” on page 353.

System related errors, which are intermittent and permanent machine errors and system I/O errors, are handled automatically by CP, in a way that is completely transparent to the user. However, when an error occurs, CP records it and sends a message to your z/VM primary system console. The message notifies you of the error and indicates whether the:

- ▶ System operation can continue
- ▶ System operation can continue, but with fewer resources
- ▶ System restart and recovery is beginning

If the error occurred in an identified virtual machine, provided that the overall z/VM system’s integrity is preserved, a soft *abend* occurs. During a soft abend, CP takes a soft abend dump, and operations continue.



If the error is more critical, CP terminates in a hard abend. During the abend:

- ▶ CP saves z/VM spool files and system data file queues.
- ▶ CP takes a hard abend dump, that can be used later for debugging purposes.
- ▶ CP tries to restart itself and the operator's console virtual machine.

**Note:** All guest operating systems that were running before the abend have to be restarted manually, unless the appropriate IPL commands have been set up.

If CP is not able to restart, it informs you of the required steps to recover from the error.

## 8.1.2 z/VM error codes

Most of z/VM error codes follow the same format. The code has a message identifier and message text.

The message identifier is one of the following formats:

```
xxxmmm###s  
xxxmmm####s
```

The format indicates the following information:

- ▶ First 3 characters (xxx) is the prefix identifying the component. See Table 8-1 on page 354 for a list of the major component identifiers.
- ▶ Next 3 characters (mmm) is the module code that identifies, in a given component, the module or function that fails.
- ▶ Following 3 or 4 digits (### or ####) is the message number itself.
- ▶ The last digit (s) can be one of the following severity codes:
  - A** Immediate action is required
  - D** Decision
  - E** Error
  - I** Information only
  - R** Response
  - S** Severe Error
  - T** Terminating Error
  - W** System Wait (CP only), warning (all others)

Table 8-1 on page 354 lists the component prefix identifiers for the first three characters in the message.

Table 8-1 z/VM major components identifiers

Prefix	z/VM component
DMS	CMS (Conversational Monitoring System)
DTC	TCP/IP for z/VM
DVH	Directory Maintenance Facility for z/VM
FCX	Performance Toolkit for z/VM
HCP	CP (Control Program)
RAC	RACF Security server
TCP	TCP/IP for z/VM

This list is not exhaustive. For more information, see the *z/VM: CP Messages and Codes*, GC24-6119, located at:

<http://publib.boulder.ibm.com/infocenter/zvm/v5r3/topic/com.ibm.zvm.v53.hcpw0/msgfrmt.htm#msgfrmt>

To find an explanation of the error messages, including hints to solve the problem, use the HELP command. For instance, to find an explanation for the error message shown in Example 8-1 on page 352, type the following command:

```
help HCPLGA053E
```

The result is shown in Example 8-2.

*Example 8-2 HCPLGA053E error message help*

---

```
MSG HCPLGA053E          All Help Information          line 1 of 12
(c) Copyright IBM Corporation 1990, 2007
```

```
HCPO53E (XAUTOLOG failed for userid:) <userid|value> not in CP directory
```

Explanation: The user ID supplied was not found in the z/VM directory. If the command was an asynchronous XAUTOLOG, the message indicates which user ID did not get logged on.

System Action: The command is not executed; system operation continues.

User Response: Reissue the command with a valid user ID.

```
* * * End of File * * *
```

---

**Note:** In the HELP command, you may omit the 3-digit module code. The command HELP HCP053E gives the same result.

For more details about the HELP command, refer to section 2.5.1, “Overview of the HELP command in CMS” on page 36.

### 8.1.3 Linux error handling

In a Linux virtual machine, the Linux kernel is responsible for the correct resources allocation and isolation of the processes that run. The kernel tries to recover from errors as transparently as possible for applications and users.

Most errors are application errors, bad programming practices, or invalid input data. If an application tries to allocate resources it is not allowed to use, for instance writing to a memory page already in use by another application, the Linux kernel issues a segmentation fault, also known as segfault or SIGSEGV, and the application ends abnormally. A coredump file is created for further analysis of the error in the application. This ensures an application does not interfere with another.

When an unrecoverable error occurs, the Linux kernel goes into *kernel panic* mode. It writes an error message on the console, saves an image of the memory on the disk for post-mortem debugging, and reboots. Classical causes of kernel panics are attempts to read or write an invalid or restricted memory address. Sometimes, hardware failures can also result in kernel panics.

### 8.1.4 Linux error codes

Compared to z/VM, Linux does not have a predefined error messages format. Most of the error messages are made of one or more strings that identify the component that encountered the error, either the kernel itself or a daemon, and a message indicating the cause of the error. For instance, Example 8-14 on page 369 shows an error message from the kernel module qeth.

In some cases, the return code of the application can also be considered as the error message. Return codes different from zero indicate something wrong in the application.

**Note:** Even though Linux provides several predefined codes for errors and returns in its standard library, developers may also define their own error codes that differ from the standard.

## 8.2 z/VM tools for error gathering and analysis

As a z/VM system operator, your responsibility is to ensure that all the resources available to the z/VM LPAR are available to users to get their jobs done. Part of a system operator's responsibilities includes collecting information about tasks:

- ▶ Accounting
- ▶ System performance
- ▶ System events
- ▶ Error recording

A set of default users is available in z/VM to accomplish those tasks:

- ▶ DISKACCNT collects accounting and billing information.
- ▶ OPERSYMP records symptoms records.
- ▶ OPERATOR logs system events.
- ▶ EREP records error records.

To check the status of the various recordings on a z/VM system, the command **query recording** (abbreviated as **q rec**) can be used, as shown in Example 8-3.

*Example 8-3 Output of the query rec command*

---

```
q rec
RECORDING  COUNT  LMT USERID  COMMUNICATION
EREP      ON  00000000  002 EREP    ACTIVE
ACCOUNT   ON  00000000  020 DISKACNT ACTIVE
SYMPTOM   ON  00000000  002 OPERSYMP ACTIVE
Ready; T=0.01/0.01 14:58:23
```

---

This chapter focuses on collecting systems events and error recording.

### 8.2.1 Collecting information about system events

When z/VM IPLs, the system operator machine (OPERATOR by default) is automatically logged on; if the NOAUTOLOG parameter has been specified at IPL time, no other machines are started. On the OPERATOR console, all system-related and error messages are displayed. All commands issued by the operator, and answers to these commands, are also displayed on the OPERATOR console.

The system operator machine is defined in the z/VM configuration file, SYSTEM CONFIG, as shown in Example 8-4.

*Example 8-4 System Userids configuration*

---

```
/*
System Userids */
*****/

System_Userids ,
  Operator OPERATOR ,
  Account  DISKACNT ,
  Dump     OPERATNS ,
  Erep     EREP
```

---

This console log can be saved to a spool file, so you can analyze it later. In case of a system abend, CP also automatically saves the console log to a spool file.

### Status of console logging

To determine whether the console activity is logged into a file, issue the command QUERY VIRTUAL CONSOLE (abbreviated as **q v console**, or **q v con**), as shown in Example 8-5. The first line of the output says STOP, meaning console logging is not enabled.

*Example 8-5 Status of console logging*

---

```
q v console
00: CONS 0009 ON LDEV L0003  TERM STOP  HOST TCPIP    FROM
9.57.138.243
00: 0009 CL T NOCONT NOHOLD COPY 001  READY FORM STANDARD
00: 0009 TO LNXGUI  PRT DIST LNXGUI  FLASHC 000 DEST OFF
00: 0009 FLASH     CHAR    MDFY     0 FCB    LPP OFF
00: 0009 3215  NOEOF CLOSED  NOKEEP NOMSG NONAME
00: 0009 SUBCHANNEL = 0008
Ready; T=0.01/0.01 15:28:01
```

---

### Enabling console logging

To enable console logging in a virtual machine, such as LNXGUI, use the command CP SPOOL CONSOLE START (abbreviated as **cp sp con start**), as shown in Example 8-6 on page 358. Check the status again with **query virtual console**. The first line of the output should say START, meaning console logging is started.

### Example 8-6 Enabling console logging

---

```
q v console
00: CONS 0009 ON LDEV L0003  TERM STOP HOST TCPIP   FROM 9.57.138.243
00:    0009 CL T NOCONT NOHOLD COPY 001   READY FORM STANDARD
00:    0009 TO LNXGUI  PRT DIST LNXGUI    FLASHC 000 DEST OFF
00:    0009 FLASH     CHAR      MDFY      0 FCB      LPP OFF
00:    0009 3215  NOEOF CLOSED  NOKEEP  NOMSG  NONAME
00:    0009 SUBCHANNEL = 0008
Ready; T=0.01/0.01 15:28:01
cp spool console start
Ready; T=0.01/0.01 15:31:13
q v console
00: CONS 0009 ON LDEV L0003  TERM START HOST TCPIP   FROM 9.57.138.243
00:    0009 CL T NOCONT NOHOLD COPY 001   READY FORM STANDARD
00:    0009 TO LNXGUI  PRT DIST LNXGUI    FLASHC 000 DEST OFF
00:    0009 FLASH     CHAR      MDFY      0 FCB      LPP OFF
00:    0009 3215  NOEOF OPEN 0039 NOKEEP  NOMSG  NONAME
00:    0009 SUBCHANNEL = 0008
Ready; T=0.01/0.01 15:31:19
```

---

In Example 8-7, we ensure console logging is activated next time the virtual machine IPLs, by adding the statement **CP SPOOL CONSOLE START** to the LNXGUI machine PROFILE EXEC.

### Example 8-7 Updating PROFILE EXEC

---

```
PROFILE EXEC      A1  V 130  Trunc=130 Size=3 Line=0 Col=1 Alt=2

===== * * * Top of File * * *
      |...+...1...+...2...+...3...+...4...+...5...+...6...+...7...
===== /* */
===== 'CP SET PF12 RETR'
===== 'CP SPOOL CONSOLE START'
===== * * * End of File * * *

=====>
```

X E D I T 1 File

---

## Saving console log to a file

To save the console log to a file, you must stop console logging. A file is then created in the machine's virtual printer. This file can either be printed directly or sent to the virtual reader for further processing. Example 8-8 on page 359 shows the commands used for this purpose.

*Example 8-8 Saving console log to a file*

---

```
cp sp console close
00: PRT FILE 0041 SENT FROM LNXGUI   CON WAS 0041 RECS 0131 CPY  001 T NOHOLD
NO
KEEP
Ready; T=0.01/0.01 16:47:06
change prt all to * rdr
00: RDR FILE 0041 SENT FROM LNXGUI   PRT WAS 0041 RECS 0131 CPY  001 T NOHOLD
NO
KEEP
00: 0000001 FILE  CHANGED
Ready; T=0.01/0.01 16:47:16
```

---

The command `CP SPOOL CONSOLE CLOSE` (abbreviated as `cp sp console close`, or `cp sp con close`) closes the current log file, and opens another one. The current log file is sent to the virtual machine printer. This file has spoolid 0041.

The command `change printer all to * readerr` (abbreviated in the example as `change prt all to * rdr`) moves all files from the machine virtual printer to its virtual reader. The asterisk (\*) means *myself*, the virtual machine in which the command is issued.

**Note:** You may use a single command to close the spool and have it sent to your reader:

```
cp sp console close *
```

To send only one specific file from the printer to the reader of a virtual machine, specify the spoolid of the file to transfer:

```
ch prt 0041 to * rdr
```

When the files are in the reader, you may list them by using the `RL` command and browse by using the `PEEK spool id` command (which is mapped to the F11 key in the reader's list window) as shown in Example 8-9. They can also be saved to disk and archived.

*Example 8-9 Displaying a console log file*

---

```
0041   PEEK   A0 V 133 Trunc=133 Size=131 Line=52 Col=1 Alt=0
File (none) (none) from LNXGUI at VMLINUX6 Format is CONSOLE.
z/VM V5.3.0   2008-05-06 13:40

Ready; T=0.01/0.01 16:45:57
q da all
00: HCPQVC022E A virtual device number was not supplied or it was invalid.
```

```

Ready(00022); T=0.01/0.01 16:46:04
q da
00: DASD 0101 9336 (VDSK) R/W      200000 BLK ON DASD  VDSK SUBCHANNEL = 0001
00: DASD 0190 3390 LX6RES R/O      107 CYL ON DASD   1A20 SUBCHANNEL = 0009
00: DASD 0191 3390 LX6W02 R/W      10 CYL ON DASD   1A24 SUBCHANNEL = 0000
00: DASD 019D 3390 LX6W01 R/O      146 CYL ON DASD  1A23 SUBCHANNEL = 000A
00: DASD 019E 3390 LX6W01 R/O      250 CYL ON DASD  1A23 SUBCHANNEL = 000B
00: DASD 0401 3390 LX6W01 R/O      146 CYL ON DASD  1A23 SUBCHANNEL = 000E
00: DASD 0402 3390 LX6W01 R/O      146 CYL ON DASD  1A23 SUBCHANNEL = 000D
00: DASD 0405 3390 LX6W01 R/O      156 CYL ON DASD  1A23 SUBCHANNEL = 000F
00: DASD 0592 3390 LX6W01 R/O      70 CYL ON DASD   1A23 SUBCHANNEL = 000C
Ready; T=0.01/0.01 16:46:06
link * 100 100 MR
Ready; T=0.01/0.01 16:46:15
link * 150 150 MR
Ready; T=0.01/0.01 16:46:20
cp console close
Unknown CP command
Ready(-0001); T=0.01/0.01 16:46:51
q v
00: STORAGE = 512M
1= Help      2= Add line  3= Quit      4= Tab      5= Clocate  6= ?/Change
7= Backward  8= Forward   9= Receive  10= Rgtright 11= Spltjoin 12= Cursor

====>
X E D I T 1 File

```

This console log file shows all the commands that have been issued in the console of the virtual machine, and the answer to these commands. If CP encounters an error, it is logged to the console log also.

**z/OS analogy:** This is similar to z/OS SYSLOG.

You may also use a virtual machine's console to display the consoles of multiple users by using the SET OBSERVER command, or by adding a parameter in the user directory CONSOLE statement. Example 8-10 shows the CONSOLE directory statement.

*Example 8-10 LNXGUI virtual machine directory CONSOLE statement*

```

USER   DIRECT  C1 F 80 Trunc=72 Size=2041 Line=60 Col=1 Alt=1

00060  SP00L 000E 1403 A
00061  CONSOLE 009 3215 T LNXMAINT OBSERVER
00062  LINK MAINT 0190 0190 RR

```



```
00063 LINK MAINT 019D 019D RR
00064 LINK MAINT 019E 019E RR
```

---

Saving LNXMAINT machine console to a file allows the operator to analyze the messages issued from several virtual machines, as shown in Example 8-11, where LNXMAINT virtual machine is OBSERVER for LNXGUI, LNXCER, and LNXKEN.

*Example 8-11 LNXMAINT console output*

---

```
CP DISC
LNXGUI : 00: DISCONNECT AT 15:59:53 EDT THURSDAY 06/05/08
LNXGUI : 00:
Press enter or clear key to continue
LNXKEN : 00: z/VM Version 5 Release 3.0, Service Level 0701 (64-bit),
built on IBM Virtualization Technology
LNXKEN : 00: There is no logmsg data
LNXKEN : 00: FILES: 0003 RDR, NO PRT, NO PUN
LNXKEN : 00: RECONNECTED AT 16:00:02 EDT THURSDAY 06/05/08
LNXKEN : 0
LNXKEN : 0
LNXKEN : Password:
LNXCER : 00: z/VM Version 5 Release 3.0, Service Level 0701 (64-bit),
built on IBM Virtualization Technology
LNXCER : 00: There is no logmsg data
LNXCER : 00: FILES: 0003 RDR, NO PRT, 0001 PUN
LNXCER : 00: RECONNECTED AT 16:00:18 EDT THURSDAY 06/05/08
```

---

**Note:** Refrain from using the OPERATOR console as an observer or user for other machines. OPERATOR should be reserved only for system-related messages.

## 8.2.2 Collecting information about errors

By default, when z/VM is running, error data collection is turned on by CP, which generates an error record each time a hardware problem:

CP generates an error record:

- ▶ Occurs in the LPAR while CP is active.
- ▶ Occurs in a virtual machine in supervisor state.

**Note:** Error recording does not occur in virtual machine in emulation state, unless the user has issued the CP SET SVC76 command in this virtual machine.

z/VM error records analysis is a 3-steps process:

1. When a hardware error occurs, CP generates an error record, and notifies the error recording virtual machine.
2. The error recording virtual machine is in charge of retrieving the error records from storage and saving them to disk.
3. You process the records saved to disk to generate the reports that are used by system operators or support teams to identify problems.

Environmental Record Editing and Printing Program (EREP) is the application (virtual machine) dedicated to error-records processing in z/VM, but also in z/OS and z/VSE.

## Generating EREP reports

EREP functions can be used to create many types of reports:

- ▶ System Summary Report  
This provides an overview of errors for each component of the environment: CPU, storage, channels, I/O subsystem.
- ▶ System Exception Report  
This lists software and hardware error data in a variety of ways.
- ▶ Threshold Summary Report  
This shows all the permanent read/write errors, temporary read/write errors, and media statistics for each volume mounted, for 3410, 3420, and 8809 tape devices.
- ▶ CCH and MCH Detail Report  
This reports Channel CChecks and Machine CChecks.
- ▶ MDR and OBR Detail Report for Controllers  
This reports 3704, 3705, 3720, 3725, and 3745 tape controllers-related errors.
- ▶ Detail Summaries for I/O Errors  
This summarizes I/O errors.
- ▶ Detail Reports for Software Records  
This reports the details of software records.

► Trends Report

This presents the pattern and frequency of errors on a daily basis. These reports show when the errors began, their pattern, and when they end.

► Event History Report

This shows errors in a time sequence that allows you to see how often and in what order errors occur.

EREP reports are generated by the CPEREPXA class F command, with a defined set of arguments. To generate an EREP report under z/VM, you must define the input and output files using FILEDEFS and then invoke the CPEREPXA EXEC command. You enter CPEREPXA and EREP operands either as a parameter file or at the CPEREPXA prompt.

**Note:** EREP virtual machine stores error records on its 191 disk, in files named XAEREPIO RECORD and XAREPMC RECORD.

**z/OS analogy:** To create EREP reports under z/OS, it is necessary to define the input and output data sets using JCL DD statements. The JCL submits the job as a batch job or interactively via TSO. Put the IFCEREP1 program in the JCL EXEC statement. Include the EREP parameters on the EXEC statement or as part of SYSIN in-stream data with the EREP control statements.

Detailing all configuration options of CPEREPXA is beyond the scope of this book. For complete reference and detailed options, see the *EREP V3R5 User's Guide*, GC35-0151, at:

<http://publib.boulder.ibm.com/infocenter/zvm/v5r3/topic/com.ibm.zos.r9.ifc1000/ifc5g102.htm>

Example 8-12 shows a System Summary Report generated by CPEREPXA.

*Example 8-12 Example of System Summary Report*

```
SYSTEM  SUM      A1  F 132  Trunc=132 Size=95 Line=2 Col=1 Alt=0
====>
 2 S Y S T E M  S U M M A R Y                REPORT DATE 141 08
 3              (PART 1)                    PERIOD FROM 065 08
 4 CPU/CHANNEL/STORAGE/SCP                    TO 115 08
 5
 6              TOTAL CPU-0
 7 IPL                      54    54
 8
 9 MACHINE CHECK
10
```

11	RECOVERABLE	0	0
12	NON-RECOVERABLE	0	0
13			
14	CHANNEL CHECK		
15			
16	CHANNEL 0	0	0
17	CHANNEL 1	0	0
18	CHANNEL 2	0	0
19	CHANNEL 3	0	0
20	CHANNEL 4	0	0
21	CHANNEL 5	0	0
22	CHANNEL 6	0	0
23	CHANNEL 7	0	0
24	CHANNEL 8	0	0
25	CHANNEL 9	0	0
26	CHANNEL A	0	0
27	CHANNEL B	0	0
28	CHANNEL C	0	0
29	CHANNEL D	0	0
30	CHANNEL E	0	0
31	CHANNEL F	0	0
32			
33	PROGRAM ERROR		
34			
35	ABEND	344	344
36	PRGM INT	21	21
37			
38	END OF DAY	0	0
39			
40	CPU MODEL SERIAL NO.		
41	0 2084XA 0BE34E		
42			
43	S Y S T E M S U M M A R Y		
44	(PART 1 CONTINUED)		
45	SUBCHANNEL/CHANNEL		
46			
47	TOTAL CPU-0		
48			
49	SUBCHANNEL LOGOUT		
50			
51	CHANNEL REPORT WORD		
52			
53	HARDWARE	0	0
54	SOFTWARE	0	0
55			
56	TOTAL RECORDS	419	419
57			
58	CPU MODEL SERIAL NO.		
59	0 2084XA 0BE34E		

REPORT DATE 141 08  
PERIOD FROM 065 08  
TO 115 08

```

60
61 S Y S T E M   S U M M A R Y           REPORT DATE 141 08
62      (PART 2)                       PERIOD FROM 065 08
63      I/O SUBSYSTEM                   TO 115 08
64
65      ----- TOTAL ----- CPU-0
66      PERM  TEMP  PATH  PERM  TEMP
67 DASD *****
68
69 2107-SSID 8A00    0    3    0    -    -
70 2107-SSID 8C00    0    3    0    -    -
71 2107-SSID 8000    0    5    0    -    -
72 2107-SSID 8400    0    7    0    -    -
73 2107-SSID 8600    0   14    0    -    -
74 2107-SSID 8700    0    2    0    -    -
75 2107-SSID 8800    0    4    0    -    -
76
77 TAPE *****
78
79 3590 FA50         0    1    0    0    1
80 3590 FA51         0    1    0    0    1
81 3590 FB00         0    1    0    0    1
82 3590 FB01         0    1    0    0    1
83 3590 FB02         0    1    0    0    1
84 3590 FB03         0    1    0    0    1
85 3590 FB10         0    1    0    0    1
86 3590 FB11         0    1    0    0    1
87 3590 FB12         0    1    0    0    1
88 3590 FB13         0    1    0    0    1
89 3590 FB30         0    2    0    0    2
90 3590 FB40         1    6    0    1    6
91 3590 FB41         0    7    0    0    7
92
93 TOTALS           1   63    0    1   25
94 CPU  MODEL  SERIAL NO.
95 0   2084XA 0BE34E
96 * * * End of File * * *

```

---

### 8.2.3 Dumps and traces

This section gives an overview of the dumps and traces facility in z/VM.

#### Dumps

A *dump* is a picture of either the virtual machine or the partition's storage. If a problem is encountered, it can probably be found somewhere in this picture. A dump can be used to identify the moment in time when malfunctions begin.

Several z/VM components can generate dumps:

- ▶ CP itself
- ▶ A virtual machine in which CMS, or another z/VM component, or a guest operating system is running
- ▶ A communication controller

Several types of dumps are available in z/VM, depending on the component that created it, or the information required for analysis:

- ▶ A CP dump. This is a dump of the storage directly owned by CP. It is generated by CP during a hard abend and results in system termination and possibly a restart.

**Note:** The `query dump` command (abbreviated as `q dump`) shows the device that will be used to store the CP DUMP file. CP DUMPs are created in the virtual reader of the virtual machine defined in the SYSTEM CONFIG, under System\_UserIDs - OPERATNS by default. See Example 8-4 on page 357 for an example SYSTEM CONFIG Dump statement.

- ▶ A snapdump. This is a dump of the storage directly owned by CP and is very similar to a hard abend dump but does not result in system termination.
- ▶ A CP soft abend dump. This is a dump of a small amount of the storage directly owned by CP. It is created when CP encounters a problem where system integrity is not compromised by the error, or when CP can isolate an error to a virtual machine. It does not result in system termination.
- ▶ A stand-alone dump. Sometimes, a problem can be so severe that your system cannot even produce a CP dump on its own. For this reason, every z/VM system is equipped with a special program that produces a dump of real storage, regardless of how severe the problem is. It is called a stand-alone dump because the program that produces it stands alone or is independent of the rest of the system programming. Because it is independent of the system programming, any problems there do not prevent the dump from being created.
- ▶ A dump limited to any single virtual machine (VMDUMP) running in your z/VM system. For example, you can request a dump of a virtual machine containing CMS, RSCS, or any guest operating system that resides in a virtual machine.
- ▶ A dump of a communication controller's storage.

If your virtual machine is running a Guest operating system such as Linux or z/OS, it is recommended to use the tools available for that operating system rather than the z/VM dump tools. Refer to 8.3.2, "Error analysis tools" on page 372 for a discussion about Linux dump tools.

For more details about VM dump tools, please refer to *z/VM V5R3.0 Diagnosis Guide*, GC24-6092, located at:

<http://publib.boulder.ibm.com/infocenter/zvm/v5r3/index.jsp?topic=/com.ibm.zvm.v53.hcpc1/getdump.htm>

**z/OS analogy:** in z/OS, a dedicated dump address space is used to capture dump onto DASD.

User-initiated dumps are also saved in the dump address space.

## Traces

The virtual machine tracing facility allows you to follow, or *trace*, the execution of almost anything that takes place while you are using your virtual machine. For example, you can trace instructions, I/O interrupts, branches, and changes to storage.

Tracing the execution of programs inside a virtual machine can help system operators and support teams to identify the step in a program where execution fails. Example 8-13 shows the output of the TRACE I/O command run in a Linux guest.

*Example 8-13 Tracing I/O in a Linux guest running cat /root/.viminfo command*

---

```
00: EXTENT          80C00000 0000000A 0008000D 0008000D
00: CCW  1F209FC0 47400010 1F209FF0 0008 47400010 .....
00: LOCATE RECORD   01800001 0008000D 0007000D 01061000
00: CCW  1F209FC8 85001000 1DE19000 0010 85041000 .....
00: IDAL           00000000DAAED000
00: -> 00000000208C790E' SIGA B2740000 0000000000000000 CC 0
00:      SCH 0006  DEV 0602
00:      FC 00000001  MASK 80000000 00010006
00: -> 0000000000332258' SSCH B2333000 00000000010F4844 CC 0
00:      SCH 0001  DEV 0100
00:      CPA 1F209FB8  PARM 010F4800  KEY 0  FPI C2  LPM F0
00: VDEV 0100 CCW 63600020 1F209FD0
00: CCW  1F209FB8 63600020 1F209FD0 0000 63600020 .....
00: EXTENT          80C00000 0000000A 0008000D 0008000D
00: CCW  1F209FC0 47400010 1F209FF0 0008 47400010 .....
00: LOCATE RECORD   01800001 0008000D 0007000D 02181000
00: CCW  1F209FC8 85001000 1E1DE000 0010 85041000 .....
00: IDAL           000000005CCCB000
00: -> 00000000208C8B52' SIGA B2740000 0000000000000000 CC 0
00:      SCH 0006  DEV 0602
00:      FC 00000000  MASK 20000000 20000000
00: -> 00000000208C8B52' SIGA B2740000 0000000000000000 CC 0
```

```
00:          SCH 0006   DEV 0602
00:          FC 00000000   MASK   20000000   20000000
00: -> 000000000208C8B52' SIGA B2740000   000000000000000000   CC 0
00:          SCH 0006   DEV 0602
00:          FC 00000000   MASK   20000000   20000000
```

---

For more information about z/VM trace command, please refer to z/VM V5R3.0 System Operation, SC24-6121 at:

<http://publib.boulder.ibm.com/infocenter/zvm/v5r3/topic/com.ibm.zvm.v53.hcpb2/uc9a.htm#uc9a>

## 8.3 Linux activity logging and error analysis

Activity logging is built in every Linux distribution. Every kernel-related message and daemon-related message is logged into a common directory, whatever the distribution is. These messages can be:

- ▶ Information messages: For instance, someone has logged on the machine through SSH from a given IP address.
- ▶ Warning messages: For instance, one of the configuration options of a daemon cannot be applied, but did not prevent the daemon from starting.
- ▶ Error messages: For instance, someone unplugged the network cable from your network interface.

Going through the contents of these log files is a first step for error identification.

### 8.3.1 Linux activity logging

Two Linux daemons responsible for logging kernel and user activities: klogd and syslog, or syslog-ng:

- ▶ klogd for kernel-related messages  
klogd is the kernel logger. It intercepts and translates the messages issued by the kernel itself, and passes them, formatted, to syslog for archiving.
- ▶ syslog and its variants for everything in the user space  
syslog is the user space logger. It collects information from various daemons running in the system, and saves the messages to files for further reference.



## Log files of interest

Whatever the distribution is, log files are saved to a common directory, named `/var/log`. However, log file names can vary from one distribution to another.

**Note:** `/var/log` is the standard location for the log messages of the daemons provided by the distribution packages. Third-party software, most of the time, saves their log files in different locations.

When you look for errors, the most relevant files in the `/var/log` directory on SUSE Linux Enterprise Server 10 and Red Hat Enterprise Linux 5, which are described in the next sections.

### **Files on SUSE Linux Enterprise Server 10**

The files are:

- ▶ The messages log file includes all system messages

Example 8-14 shows a report from the `qeth` driver informing that a network failure occurred at 16:41:21 on May 21.

#### *Example 8-14 An extract of `/var/log/messages` log file on SLES10*

```
May 21 15:17:15 lnsguill kernel: audit(1211397428.415:2): AppArmor (version
2.0-19.43r6320) initialized
May 21 15:17:15 lnsguill syslog-ng[1206]: Changing permissions on special
file /dev/xconsole
May 21 15:17:15 lnsguill syslog-ng[1206]: Changing permissions on special
file /dev/tty10
May 21 15:17:15 lnsguill kernel:
May 21 15:17:15 lnsguill kernel: Unable to find swap-space signature
May 21 15:17:23 lnsguill kernel: eth0: no IPv6 routers present
May 21 15:18:06 lnsguill sshd[1325]: Accepted keyboard-interactive/pam for
root from 9.57.138.243 port 2805 ssh2
May 21 16:17:11 lnsguill syslog-ng[1206]: STATS: dropped 0
May 21 16:41:28 lnsguill kernel: qeth: Link failure on eth0 (CHPID 0x20) -
there is a network problem or someone pulled the cable or disabled the
port.
May 21 16:41:28 lnsguill mingetty[1319]: ttyS0: invalid character for login
name found
May 21 16:42:05 lnsguill kernel: qeth: Link reestablished on eth0 (CHPID
0x20). Scheduling IP address reset.
May 21 16:42:05 lnsguill kernel: qeth: Recovery of device 0.0.0600 started
...
May 21 16:42:05 lnsguill kernel: qeth: Device 0.0.0600/0.0.0601/0.0.0602 is
a Guest LAN QDIO card (level: V530)
May 21 16:42:05 lnsguill kernel: with link type GuestLAN QDIO (portname: )
```

```
May 21 16:42:05 lnsguill kernel: qeth: Hardware IP fragmentation not
supported on eth0
```

---

- ▶ The lastlog file shows a list of the last logged-on users. Use the command LASTLOG to query this file.
- ▶ The faillog file shows the users that failed to log on. Use the command FAILLOG to query this file.
- ▶ The warn file contains warning information such as access-denied from SSH, for instance.

### ***Files on Red Hat Enterprise Linux 5***

- ▶ The messages file includes all system messages.
- ▶ The lastlog file shows a list of the last logged-on users
- ▶ The faillog file shows the users that failed to log on.
- ▶ The secure file shows all security related messages.

### **Browsing log files**

Many commands are available to browse log files.

The most standard way to browse a log file is to open it using a text editor. Another convenient way to display log files is to use the `tail` command, which outputs the last lines of the files. See Example 8-15. The output is refreshed each time a new time is written in the file. This command allows live log monitoring, so it is a convenient way to see what is written to the files when trying to reproduce an error.

#### *Example 8-15 Output of tail -f /var/log/messages*

---

```
lnsguill:~ # tail -f /var/log/messages
May 29 13:54:30 lnsguill kernel: AppArmor: AppArmor (version
2.0-19.43r6320) initialized
May 29 13:54:30 lnsguill kernel: audit(1212083662.366:2): AppArmor
(version 2.0-19.43r6320) initialized
May 29 13:54:30 lnsguill syslog-ng[1209]: Changing permissions on
special file /dev/xconsole
May 29 13:54:30 lnsguill syslog-ng[1209]: Changing permissions on
special file /dev/tty10
May 29 13:54:30 lnsguill kernel:
May 29 13:54:30 lnsguill kernel: Unable to find swap-space signature
May 29 13:54:35 lnsguill kernel: eth0: no IPv6 routers present
May 29 13:54:46 lnsguill sshd[1256]: error: PAM: Authentication failure
for root from 9.57.138.243
```

```
May 29 13:54:49 lnsguill sshd[1256]: Accepted keyboard-interactive/pam
for root from 9.57.138.243 port 2063 ssh2
May 29 14:02:55 lnsguill sshd[1332]: Accepted keyboard-interactive/pam
for root from 9.57.138.243 port 2102 ssh2
```

---

The **head** command does the same thing, but displays only the first lines of a log file. The **dmesg** command displays the messages logged by the kernel logger daemon.

## Log files archiving

To avoid storing large amounts of data, the log files are rotated on a regular basis. The rotation process is managed by the **logrotate** command, which is controlled by a *cronjob* launched daily. For more information about cronjob, refer to section 5.4.1, “Job scheduling” on page 275.

Depending on the configuration options of **logrotate**, log files are kept several days or weeks, compressed or not, until they reach a certain age or size.

As shown in Example 8-16, the older messages log file has been rotated four times, compressed, and kept on disk. These were the defaults for SUSE Linux 9.

### Example 8-16 Content of /var/log/ directory

---

```
mastervml2:/var/log # ls -al
total 3424
drwxr-xr-x  5 root root  4096 May 16 04:15 .
drwxr-xr-x 13 root root  4096 Jan 16  2007 ..
drwx-----  2 root root  4096 Feb 12 15:10 YaST2
drwxr-x---  2 root root  4096 Feb 12 10:11 apache2
-rw-r-----  1 root root      0 Jan 16  2007 boot.log
-rw-r--r--  1 root root 13651 Apr 19 23:13 boot.msg
-rw-r--r--  1 root root 15623 Apr 19 23:12 boot.omsg
-rw-r--r--  1 root root   586 Jan 16  2007 convert_for_getconfig.log
-rw-----  1 root root 32096 Apr 10 00:15 faillog
-rw-r--r--  1 root tty 296888 May 27 21:27 lastlog
-rw-r--r--  1 root root   474 Dec  6 15:37 localmessages
-rw-r-----  1 root root   5334 Apr 30 17:20 mail
-rw-r-----  1 root root   1796 Apr 30 17:20 mail.err
-rw-r-----  1 root root   5334 Apr 30 17:20 mail.info
-rw-r-----  1 root root   3974 Apr 30 17:20 mail.warn
-rw-r-----  1 root root 214109 May 27 21:27 messages
-rw-r-----  1 root root 333920 Dec 11 04:15 messages-20071211.gz
-rw-r-----  1 root root 340177 Feb  2 04:15 messages-20080202.gz
-rw-r-----  1 root root 337732 Feb 21 04:15 messages-20080221.gz
-rw-r-----  1 root root 329943 May 16 04:15 messages-20080516.gz
[...]
```

---

In SUSE Linux 10, a new log file is created each time the current `/var/log/messages` file reaches 4 Mb in size; log files are rotated 99 times before being removed. The `logrotate` and `syslog` configuration files can be found in `/etc/logrotate.*` and `/etc/syslog.conf` locations.

For more information about `logrotate` and `syslog` configuration, refer to the corresponding manual pages.

Fine-tuning `syslog` and `logrotate` processes can be necessary to keep the correct number of log files according to your security and audit strategy.

### **Centralized remote logging**

The final noteworthy feature of `syslog` is its full remote logging capability; `syslogd` is able to send messages to a remote host running `syslogd` and to receive messages from remote hosts. The remote host does not forward the message again, but logs the messages locally.

Using this feature you are able to control all `syslog` messages on one host, if all other machines log remotely to that. This decreases administration needs.

Refer to the `syslogd` manual page for more details.

## **8.3.2 Error analysis tools**

This section discusses dumps and traces used as error analysis tools.

### **Dumps, as an error analysis tool**

Sometimes not enough relevant information can be found in the log files. To analyze the reasons one of the Linux guests running in a z/VM partition has a bad behavior, run a dump tool on one of the virtual machine for further analysis. Depending on the environment, several tools can be used:

- ▶ DASD dump tool generates a dump on 3390 or 3380 disks.
- ▶ SCSI dump tool generates a dump on FCP/SCSI devices.
- ▶ Tape dump tool generates a dump on tape.
- ▶ VMUDUMP creates a dump of a guest virtual memory.

Refer to Table 8-2 on page 373 for a list of the available tools.

Table 8-2 Available dump tools

Tool	Stand-alone tools			VMDUMP
	DASD	SCSI	Tape	
<b>Environment</b>	VM and LPAR	LPAR only	VM and LPAR	VM only
<b>Speed</b>	Fast	Fast	Slow	Medium
<b>Medium</b>	ECKD or FBA DASD	Linux file system on a SCSI disk	tape cartridges	VM reader
<b>Compression possible</b>	no	yes	yes	no
<b>Disruptive</b>	yes	yes	yes	no

Describing how to use all these tools is beyond the scope of this book. A detailed process for using a dump tool is described in the *Linux on System z: Using the Dump Tools*, SC33-8412, which you can download from the developerWorks Web site at:

[http://www.ibm.com/developerworks/linux/linux390/development\\_documentation.html#3](http://www.ibm.com/developerworks/linux/linux390/development_documentation.html#3)

### Traces, as an error analysis tool

Another useful way of identifying the failing step in the execution of a program is to trace the program. Linux provides many tools to trace the execution of a program. One tool is called *strace*.

In the simplest case, *strace* runs the specified command until it exits. It intercepts and records the system calls which are called by a process and the signals which are received by a process. The name of each system call, its arguments and its return value are printed on standard error or to the file specified with the **-o** option. The *strace* tool is useful as diagnostic, instructional, and debugging tool. System administrators, diagnosticians, and trouble-shooters find it invaluable for solving problems with programs for which the source is not readily available because they do not have to be recompiled to trace them. And programmers find that, because system calls and signals are events that happen at the user/kernel interface, a close examination of this boundary is very useful for bug isolation, sanity-checking, and attempting to capture race conditions.

Example 8-17 on page 374 shows the beginning of the *strace* output when tracing the **ls** command. All system calls are detailed, with their parameters and the return codes sent. This can be used to identify which step of a program fails.

### Example 8-17 Using stracing with the ls command

```
lnxguill:/mnt/backup # strace ls
execve("/bin/ls", ["ls"], [/* 55 vars */]) = 0
brk(0) = 0x80018000
mmap(NULL, 4096, PROT_READ|PROT_WRITE, MAP_PRIVATE|MAP_ANONYMOUS, -1, 0) =
0x2000001f000
uname({sys="Linux", node="lnxguill", ...}) = 0
access("/etc/ld.so.preload", R_OK) = -1 ENOENT (No such file or directory)
open("/etc/ld.so.cache", O_RDONLY) = 3
fstat(3, {st_mode=S_IFREG|0644, st_size=33471, ...}) = 0
mmap(NULL, 33471, PROT_READ, MAP_PRIVATE, 3, 0) = 0x20000020000
close(3) = 0
open("/lib64/librt.so.1", O_RDONLY) = 3
```

**Note:** Working closely with the development team of the application is necessary to analyze the output of the strace program.

This section provided a brief overview of how z/VM and Linux tools handle errors, and detailed several tools that can be used when you analyze why an application causes problems.

Sometimes, an abnormal program termination can lead to data corruption, for example if an application was writing some data to a disk when it crashed. In this case, the only option might be to restore data from an already-existing backup, to return to a state in which the data is consistent. Backup and restore tools are described in the next sections of the chapter.

## 8.4 Backup and restore

Backup refers to making copies of data so that these copies can be used to restore the original after a data loss event. These additional copies are typically called *backups* and are useful for two primary purposes:

- ▶ To restore a state following a disaster (called disaster recovery)
- ▶ To restore small numbers of files after they have been accidentally deleted or corrupted

Backups can be classified according to the way they are created:

- ▶ Offline backups are disruptive, and require planning.
- ▶ Online backups do not interrupt operations.

This chapter introduces tools available for backing up and restoring z/VM and Linux data.

## 8.4.1 z/VM offline backups

Offline backups are disruptive operations, because they require stopping the system. Using these requires proper planning because production has to be stopped.

### Copying a z/VM system to disk

Backing up a z/VM system to disk requires two z/VM partitions: one to backup and one on which the commands will be issued. The second partition must have access to the disks of the z/VM partition that are being backed up.

The process involves the following steps:

1. Shut down the z/VM system (system A) for backup.
2. On the other system (system B), vary system A disks online.
3. From system B, copy system A disks using DDR (z/VM DASD Dump/Restore program) or Flashcopy, if enabled.
4. Vary system A disks offline.
5. Re-IPL system A.

This is certainly a disruptive process because all operations have to be stopped before the system is backed up.

**Note:** Both z/VM and Linux can be saved to disk using this method.

### Backing up a z/VM system to tape

As discussed in a previous chapter, this backup also requires two z/VM partitions, the second accessing the system disk of the first partition. The second partition also must have access to a tape drive.

The process involves the following steps:

1. Attach the tape drive to z/VM system B.
2. Rewind the tape.
3. Vary online system A disks.
4. Copy system A disks onto the tape, one after the other.
5. When done, detach the tape drive, and vary offline system A disks.

**Note:** Both Linux and z/VM disks can be saved to tape using this method.

### **Backup from disk to tape**

Prerequisites include a functional tape drive attached to z/VM as 181 device, and an input file DDR VOLUMES A (see Example 8-18) containing the list of DASDs to be backed up, each one on one line.

Example 8-19 shows the script to perform a backup from disk to tape.

---

#### *Example 8-18 DDR VOLUMES A input file format*

---

```
8670
8671
8672
8673
8674
8675
8676
8677
8678
8679
```

---

---

#### *Example 8-19 Example script to backup an environment to tape*

---

```
/*DDR VOLUMES must contain input and output volumes */
Parse upper arg fn1 ft1 fm1
If fm1 = '' then fm1='A'
If fn1 = '' then do
  FN1='DDRTAPE'
  ft1='VOLUMES'
  fm1='A'
End
call traitfic
Traitement:
do i = 1 to volumes.0 by 1
  'MAKEBUF'
  parse var volumes.i volin .
  SAY "DUMPING" VOLIN "ON TAPE DEVICE 181"
  QUEUE 'IN' volin '3390'
  QUEUE 'OUT 181 3590 (LEAVE LZCOMPACT'
  QUEUE 'DUMP ALL'
  QUEUE 'YES'
  QUEUE ''
  'DDR'
  'DROPBUF'
end
EXIT
traitfic:
  'STATE' fn1 ft1 fm1
  IF RC <> 0 THEN EXIT 99
  'pipe <',
```



```
fn1 ft1 fm1,  
'| STEM VOLUMES.'  
return
```

---

### ***Restore from tape to DASD***

Requirements are a tape drive attached to z/VM as 181 device, and a RESTAPES VOLUMES A (see Example 8-20) file with the list of target DASDs to restore to. It is possible to skip some DASDs in the restore process by specifying skip in the input file.

Example 8-21 is the script used to restore from tape to DASDs.

#### *Example 8-20 Input file RESTAPE VOLUMES A*

---

```
1800  
1801  
1802  
1803  
1804  
skip  
1806  
1807  
1808  
1809
```

---

#### *Example 8-21 Example script to restore an environment from tape to disk*

---

```
/* DDR volumes must be defined in file restape volumes a */  
Parse upper arg fn1 ft1 fm1  
If fm1 = '' then fm1='A'  
If fn1 = '' then do  
  FN1='RESTAPE'  
  ft1='VOLUMES'  
  fm1='A'  
End  
call traitfic  
Traitement:  
do i = 1 to volumes.0 by 1  
  if (volumes.i,1) = 'skip' then  
  do  
    SAY "Skipping 1 disk"  
    TAPE FSF 1  
  end  
  else  
  do  
    parse var volumes.i volout .  
    call restore  
  end
```

```

end
EXIT
restore:
  'MAKEBUF'
  SAY "RESTORING TAPE DEVICE 181 TO " VOLOUT
  QUEUE 'IN 181 3590 (LEAVE'
  QUEUE 'OUT' VOLOUT '3390'
  QUEUE 'RESTORE ALL'
  QUEUE 'YES'
  QUEUE 'YES'
  QUEUE ''
  'DDR'
  'DROPBUF'
return
traiffic:
  'STATE' fn1 ft1 fm1
  IF RC <> 0 THEN EXIT 99
  'pipe <',
    fn1 ft1 fm1,
    '| STEM VOLUMES.'
return

```

---

## Backup of z/VM and Linux disks controlled from z/OS

You may integrate z/VM and Linux into pre-existing z/OS backup and restore procedures.

Linux disks must be prepared for use with the command **dasdfmt**, which allows you to format a disk using a specific layout, Linux disk layout, or compatible disk layout.

Compatible disk layout is the default layout for **dasdfmt**. It means a special handling of the first two tracks of the volume by writing a volume table of contents (VTOC) on the disk. This enables other System z operating systems to access this device (for example, for backup purposes).

This VTOC allows a Linux disk to be accessed from z/OS. This disk can be seen as a data set called, for instance, LINUX.V0X0200.PART0001.NATIVE; this data set can be saved using standard z/OS DFSMSdss™ DUMP commands.

**z/OS analogy:** The following JCL is an example of a job to backup a Linux disk from z/OS using DFSMSdss dump:

```

//STEP1 EXEC PGM=ADDRSSU,REGION=0M
//IDIOT DD DISP=(NEW,CATLG),DSN=backup.dsn.....
//SYSPRINT DD SYSOUT=*
DUMP INDY(1nxvol) OUTDD(IDIOT)

```

DFSMSdss dump can also be used to perform z/VM backup. In this case, a necessary physical dump must be performed in which you specify the tracks range to be copied.

**z/OS analogy:** The following JCL is an example of a job to back up a z/VM disk (3390-03) from z/OS using DFSMSdss dump:

```
//STEP1 EXEC PGM=ADRSSU,REGION=0M
//IDIOT DD DISP=(NEW,CATLG),DSN=backup.dsn.....
//SYSPRINT DD SYSOUT=*
        DUMP TRACKS(0,0,3338,14) -
        INDY(LX6RES) OUTDD(IDIOT) ADMINISTRATOR CPVOLUME
```

## 8.4.2 z/VM online backups

Online backups can also be called hot backups. They do not require the system to be shut down before performing the backup.

### Using SPXTAPE to backup spool files

You may back up spool and system data files (that are printer, reader, and punch files) and saved segments, NLS files, and image libraries to tape by using the CP command SPXTAPE.

The SPXTAPE command allows the you to selectively backup to tape and restore to disk spool and system data files. All files can be dumped, or a filter applied to only save the matching files.

### Copying z/VM CPOWNERD minidisks

You may perform a hot backup of a running z/VM system by copying z/VM system disks. This is a non disruptive backup, because the system continues to run while the disks are copied.

Each CPOWNERD disk has a corresponding fullpack MDISK definition in the MAINT user directory, as shown in Example 8-22.

**Note:** CPOWNERD disks added after z/VM installation should also be added as fullpack MDISKS in MAINT USER DIRECTORY for consistency.

*Example 8-22 CP owned disks, and corresponding MDISKS definitions*

Ready; T=0.01/0.01 15:35:36

q cponw

Slot	Vol-ID	Rdev	Type	Status
1	LX6RES	1A20	Own	Online and attached

```

2 LX6SPL 1A21 Own Online and attached
3 LX6PAG 1A22 Own Online and attached
4 LX6W01 1A23 Own Online and attached
5 LX6W02 1A24 Own Online and attached

```

Ready; T=0.01/0.01 15:35:38

**q v da**

```

DASD 0122 3390 LX6SPL R/W      3339 CYL ON DASD 1A21 SUBCHANNEL = 000A
DASD 0123 3390 LX6RES R/W      3339 CYL ON DASD 1A20 SUBCHANNEL = 000B
DASD 0124 3390 LX6W01 R/W      3339 CYL ON DASD 1A23 SUBCHANNEL = 000C
DASD 0125 3390 LX6W02 R/W      3339 CYL ON DASD 1A24 SUBCHANNEL = 000D

```

Ready; T=0.01/0.01 13:35:12

---

These minidisks can be copied onto a new set of disks by using DDR, or Flashcopy if enabled. Example 8-23 shows the set of inputs required to copy the first disk.

*Example 8-23 Copying z/VM disks using DDR*

---

```

ddr
z/VM DASD DUMP/RESTORE PROGRAM
ENTER:
IN 123 3390
ENTER:
OUT 1B34 3390
ENTER:
COPY ALL
HCPDDR711D VOLID READ IS LX6RES
DO YOU WISH TO CONTINUE? RESPOND YES, NO OR REREAD:
YES
HCPDDR711D VOLID READ IS DK1B34
DO YOU WISH TO CONTINUE? RESPOND YES, NO OR REREAD:
YES
COPYING LX6RES
END OF COPY
ENTER:

END OF JOB
PRT FILE 0172 SENT FROM MAINT PRT WAS 0172 RECS 0006 CPY 001 A NOHOLD
NOKEEP
Ready; T=0.09/1.13 13:41:07

```

---

All z/VM CPOWNERD disks should be copied, with the exception of the paging disks that can simply be formatted and allocated as a paging device. This paging device must, however, have the same label that the existing paging device has, otherwise the copied z/VM system will not IPL correctly.

**Note:** A good practice is to change the system DASDs labels after you have copied your z/VM system. Refer to 4.3.3, “Relabeling the system volumes” on page 165 for more details.

This copy operation results in a brand new z/VM system, ready to IPL. The IPL must be FORCED, because no warm-start data was recorded. For more information about warm-start data, refer to 5.2.1, “z/VM IPL workflow” on page 230.

**Important:** Although spool files such as the reader, printer or punch files can be lost during the copy process, this should not cause a problem restarting z/VM and the Linux virtual machines that were running in the environment.

This method cannot be applied to backups of running Linux machines. Back up of running Linux machines can lead to data inconsistency.

### 8.4.3 Linux backup tools

Linux distributions include tools for backing up and restoring data. Several are basic tools, such as tar or cpio; others are more complex, such as IBM Tivoli Storage Manager.

Although this section introduces several tools provided by the Linux distributions to perform backups, it is by no means a complete list.

**Important:** All the tools described in this section do not perform consistency checks or data integrity control.

#### Tar archiving utility

The tar utility is a standard UNIX tool to create an archive from a set of files or directories. This archive can then be compressed and saved to another set of disk or a tape. See Example 8-24.

*Example 8-24 Archiving files using tar*

```
Inxguill:~ # tar cvf varlog_backup.tar /var/log
tar: Removing leading `/' from member names
/var/log/
/var/log/YaST2/
/var/log/YaST2/y2logRPM
/var/log/YaST2/y2log
/var/log/YaST2/y2logmkinitrd
/var/log/YaST2/y2log_bootloader
```

```

/var/log/YaST2/volume_info
/var/log/YaST2/disk_dasda
/var/log/YaST2/disk_dasdb
/var/log/YaST2/disk_dasdc
[...]
/var/log/scpm
/var/log/slpd.log
/var/log/boot.msg
/var/log/dump/
lnxguill:~ # ls -al
total 5280
drwx----- 5 root root 4096 May 29 14:36 .
drwxr-xr-x 22 root root 4096 May 29 13:54 ..
-rw----- 1 root root 2098 May 29 13:59 .bash_history
-rw-r--r-- 1 root root 1332 Nov 23 2005 .exrc
drwx----- 2 root root 4096 May 20 15:07 .gnupg
-rw----- 1 root root 1024 May 20 15:13 .rnd
-rw----- 1 root root 4072 May 28 10:12 .viminfo
drwxr-xr-x 2 root root 4096 May 20 15:14 .wapi
-rw-r--r-- 1 root root 31732 May 20 15:14 autoinst.xml
drwxr-xr-x 2 root root 4096 Jun 16 2006 bin
-rw-r--r-- 1 root root 5324800 May 29 14:36 varlog_backup.tar

```

---

The resulting file, `varlog_backup.tar`, can then be compressed and saved to another disk or to a tape.

Another use of `tar` is to compress the amount of data to be sent to the backup server over SSH, as shown in Example 8-25.

*Example 8-25 Backing up using tar and ssh*

---

```

ceron:/var/log # tar cvf - /var/log | ssh 9.12.5.66 tar xvf -
tar: Removing leading `/' from member names
/var/log/
/var/log/YaST2/
/var/log/YaST2/y2logRPM
/var/log/YaST2/y2log
var/log/
var/log/YaST2/
var/log/YaST2/y2logRPM
var/log/YaST2/y2log
/var/log/YaST2/y2logmkinitrd
/var/log/YaST2/y2log_bootloader
[...]
var/log/zmd-messages.log.2008-05-25
var/log/zmd-messages.log.2008-05-26
var/log/zmd-messages.log.2008-05-27
var/log/zmd-messages.log.2008-05-28

```

---

The files in `/var/log` on `ceron` are compressed, sent with SSH to the backup server, and decompressed on the fly.

## Disk dump, using the `dd` command

The standard command `dd` can be used to perform a backup of a directory, a filesystem, a whole partition, or a disk to a disk or to a file. See Example 8-26. The same command can be used to restore the dumped data.

### *Example 8-26 Backup using `dd` command*

---

```
Inxguill:~ # dd if=/dev/dasdc1 of=/dev/dasdd1
3654528+0 records in
3654528+0 records out
1871118336 bytes (1.9 GB) copied, 181.17 seconds, 10.3 MB/s
```

---

## The `rsync` command

The `rsync` command copies files either to or from a remote host, or locally on the current host (it does not support copying files between two remote hosts). See Example 8-27.

The first time it is called, `rsync` performs a full backup of a directory. Any subsequent call to `rsync` only backs up the modified files, hence reducing the time needed for the backup.

### *Example 8-27 Backup with `rsync` command*

---

```
Inxguill:~ # rsync -av /var/log/ /mnt
building file list ... done
./
boot.log
boot.msg
boot.omsg
faillog
lastlog
mail
mail.err
mail.info
mail.warn
messages
ntp
scpm
slpd.log
warn
wtmp
zmd-backend.log
zmd-messages.log
YaST2/
```

```
YaST2/disk_dasda
YaST2/disk_dasda-1
YaST2/disk_dasdb
YaST2/disk_dasdc
YaST2/disk_dasdc-1
YaST2/macro_inst_cont.ycp
YaST2/macro_inst_initial.ycp
YaST2/volume_info
YaST2/volume_info-1
YaST2/y2log
YaST2/y2log-1
YaST2/y2log.SuSEconfig
YaST2/y2logRPM
YaST2/y2log_bootloader
YaST2/y2logmkinitrd
YaST2/y2start.log
apparmor/
apparmor/reports-archived/
apparmor/reports-exported/
apparmor/reports/
audit/
audit/audit.log
cups/
dump/
krb5/
news/
news/news.crit
news/news.err
news/news.notice
smpppd/

sent 5282837 bytes received 906 bytes 3522495.33 bytes/sec
total size is 5279388 speedup is 1.00
lnxguill:~ #

lnxguill:~ # rsync -av /var/log/ /mnt
building file list ... done
lastlog
messages
wtmp

sent 112424 bytes received 86 bytes 225020.00 bytes/sec
total size is 5279901 speedup is 46.93
```

---



## LVM2 snapshot

A snapshot is a feature of Linux Logical Volume Manager 2 (LVM2) that allows an administrator to create a new block device that presents an exact copy of a logical volume, frozen at a point in time.

Typically, LVM2 is used when some of the batch processing, a backup for instance, must be performed on the logical volume, but you do not want to halt a live system that is changing the data. When the backup of the snapshot device has been finished, the system administrator can remove the device. This facility does require that the snapshot be made at a time when the data on the logical volume is in a consistent state.

In Example 8-28, a snapshot of the logical volume `/dev/mapper/vgsystem-varloglv` has been created. This logical volume holds the `/var/log` directory, and the snapshot `/dev/mapper/vgsystem-varlogsnapshot` presents the contents of this directory frozen at one point in time, in a consistent state, that allows it to back up the data.

### *Example 8-28 Creating an LVM snapshot*

---

```
lnxguill:~ # mount
/dev/dasda1 on / type ext3 (rw,acl,user_xattr)
proc on /proc type proc (rw)
sysfs on /sys type sysfs (rw)
debugfs on /sys/kernel/debug type debugfs (rw)
udev on /dev type tmpfs (rw)
devpts on /dev/pts type devpts (rw,mode=0620,gid=5)
/dev/dasdc1 on /usr type ext3 (rw,acl,user_xattr)
/dev/mapper/vgsystem-varloglv on /var/log type ext3 (rw,acl,user_xattr)
securityfs on /sys/kernel/security type securityfs (rw)
lnxguill:~ # lvcreate -s -L 3500MB -n varlogsnapshot /dev/vgsystem/varloglv
Logical volume "varlogsnapshot" created
lnxguill:~ # mount /dev/mapper/vgsystem-varlogsnapshot /mnt/backup/
lnxguill:~ # cd /mnt/backup/
lnxguill:/mnt/backup # ls -al
total 48
drwxr-xr-x  4 root root  4096 May 29 15:09 .
drwxr-xr-x  3 root root  4096 May 29 15:17 ..
-rw-r--r--  1 root root 11398 May 29 15:09 boot.msg
drwxr-xr-x 10 root root  4096 May 29 15:06 log
drwx----- 2 root root 16384 May 29 15:05 lost+found
-rw-r----- 1 root root  1411 May 29 15:11 messages
-rw-r----- 1 root root   347 May 29 15:09 warn
```

---

For more details about Logical Volume Manager 2, see 5.3.9, “Managing DASD” on page 258.

## 8.4.4 Other available tools

Backup and restore software is available from many vendors, including:

- ▶ IBM Tivoli Storage Manager

The IBM Tivoli Storage Manager's backup and recovery solution is a centralized, comprehensive solution. It that employs smart data moves and smart data store technology, which offer quick, flexible, and low-impact backups and restores. The IBM Tivoli suite of storage products supports more than a dozen OS platforms, a variety of network connectors and more than 500 offline-storage devices.

For more information about IBM Tivoli Storage Manager, refer to the IBM Tivoli Web site:

<http://www-306.ibm.com/software/tivoli/solutions/backup/>

- ▶ CA VM:Backup

This tool can back up CMS and non-CMS data in z/VM, and Linux systems. Users can restore their individual files or minidisks; administrators can restore full volumes or entire systems. When no operating system is running on the processor, Hidro, a feature of CA VM:Backup, can provide stand-alone backup and restore.

For more information, refer to the product brief on the CA Web site:

[http://ca.com/files/ProductBriefs/vmbackup\\_pb2.pdf](http://ca.com/files/ProductBriefs/vmbackup_pb2.pdf)

- ▶ Innovation Data Processing's FDR/UPSTREAM

This storage management product is for centralized, automated, and unattended backup and restore, and archival for Open systems. Your data can be stored on a LAN/NAS/SAN. The product provides automated operations to OS/390 or z/OS MVS mainframe servers.

For more information about FDR/UPSTREAM, refer to:

<http://www.innovationdp.fdr.com/products/upstream/zlinuxups.cfm>

Database vendors also provide their own database backup tools. For instance, Oracle® provides RMAN, Recovery Manager, to handle backup and restore of their database on various platforms.

# Applying system maintenance

This chapter discusses the processes involved in maintaining a z/VM system in comparison with performing the similar processes on z/OS. It is limited to the technical aspect of these processes and does not discuss any administrative processes or routines.

## Objectives

After completing this chapter, you should be able to:

- ▶ Discuss maintenance methods provided by IBM for a z/VM system
- ▶ Explain how the maintenance is brought into production
- ▶ Identify similarities and differences between z/VM and z/OS maintenance

## 9.1 Servicing differences between z/VM and z/OS

Servicing z/VM does not differ much from servicing a z/OS system. The tasks involved are to a great extent identical for both platforms. They even have many of the terms in common. From a z/OS perspective, however, several differences exist, aside from z/VM having a higher degree of virtualization than z/OS. The differences are described in the following list:

- ▶ Service is performed from a virtual machine, normally in a much more interactive manner than what is considered common practice on z/OS. At the same time, the tools provided on z/VM are often more automated during the entire process.
- ▶ z/VM does not have the concept of manageable data sets (or even disk volumes) to the same extent that z/OS has. Architectural differences exist regarding the relationship between the system residence volumes and files containing parameterization (for instance SYSTEM CONFIG and USER DIRECT files). By design, the callable services or executables and parameterization are more bundled or tied to each other on z/VM, compared to z/OS. In z/OS, you *can* keep the SYS1.PARMLIB concatenation and RACF (or similar) user definitions isolated from the system residence volumes. Placing and referencing of data sets can also be managed by symbols in z/OS (both parameterization and catalog) to support distribution of system residence at volume level.
- ▶ The BUILD process in z/VM differs from z/OS. This process can be seen as the process you perform to distribute a serviced z/OS system. You actually service the system from within itself without having an obvious method or path to distribute for testing, is a big difference. In z/OS, you typically install service to dedicated disks and then distribute from those.
- ▶ There is also a difference in how z/VM uses its PARMLIB counterpart, the SYSTEM CONFIG file compared to how z/OS is using the PARMLIB. The SYSTEM CONFIG is read only during the IPL process, whereas the PARMLIB is also read for certain dynamic updates. Based on z/VM's possibilities to do dynamic changes without IPLs, a requirement should be (even more so compared to z/OS) to establish suitable processes to keep or track changes provided they are intended to be permanent.

## 9.2 z/VM maintenance methods

Maintenance of a z/VM system always implies logging onto a virtual machine that has the necessary privilege classes to perform the maintenance. The actual installation activities are performed from within that virtual machine. By default,

the designated virtual machine to perform system maintenance is MAINT, but z/VM sites *can* establish other virtual machines dedicated for such activities.

The maintenance is normally performed by using the “Virtual Machine Serviceability Enhancements Staged/Extended (VMSES/E)” product, which can be considered the z/VM equivalent of “System Modification Product/Extended (SMP/E)” in z/OS (providing the same set of services). VMSES/E includes a set of tools in the form of EXECs that perform the tasks necessary to maintain the z/VM system. Because of z/VM nature, the process of maintaining a z/VM system is a more interactive task, compared to z/OS. With z/OS, personnel typically prepare and run batch jobs to perform these tasks.

## 9.3 VMSES/E terminology

This section explains several terms used for z/VM maintenance.

### 9.3.1 Deliveries

General service or maintenance to a z/VM system is usually divided into the following classifications of delivery:

- ▶ Recommended Service Upgrade (RSU)
- ▶ Corrective Service (COR)
- ▶ Expanded Service Option (ESO)

The ESO is a defined collection of services in COR format. It can include services within a range of starting and ending service levels, or can be more specific or customized regarding types of service, or customized to your profile.

A downloaded file containing service is often referred to as an *envelope*.

### 9.3.2 Element terms

Element terms are described in the following list:

- ▶ The terms *authorized program analysis report (APAR)* and *program temporary fixes (PTF)* are used within VMSES/E and have the same meaning as in SMP/E.
- ▶ The term *small programming enhancement (SPE)* is used for service for installing a new release or version of a product. This corresponds to the SMP/E term FUNCTION.

- ▶ The terms *local service* or *local modifications* refer to any service not supplied by IBM on a COR or RSU service tape or other media. This includes:
  - Service such as PTFs that you have been forced to install because of errors between COR or RSU cycles
  - Any modifications caused by third-party software installations
  - Any local modifications you have installed to tailor your system

**z/OS analogy:** In SMP/E for z/OS, modifications (third-party or local) are similar to USERMODs. The PTFs installed *in between* CORs and RSUs would have no special definition attached to them.

To manage the services correctly, the *z/VM VMSES/E Introduction and Reference*, GC24-6130 publication strongly advises the use of local tracking numbers. This is similar to the use of SOURCEID in SMP/E, which can be assigned during RECEIVE and used for further processing of services.

### 9.3.3 BUILD process

When updating the z/VM Control Program (CP, also named NUCLEUS) or shared segments is necessary, the BUILD process is used.

For the CP, updating requires an IPL. In z/OS, service is applied to SYS1.NUCLEUS.

For shared segments, updating requires a restart of the affected virtual machines. A z/OS analogy would be a TSO/ISPF user logging off and on after a LINKLIST rebuild affecting one of the user's ISPF applications.

## 9.4 Comparing VMSES/E and SMP/E

VMSES/E is normally invoked by executing VMFINS using parameters for the different types of tasks to perform. However, other executables are provided to perform more compound activities (chained, logically controlled execution of more than one VMSES/E exec). These executables perform much like a batch job having multiple steps and conditional execution.

For detailed information about using VMSES/E, see *z/VM VMSES/E Introduction and Reference*, GC24-6130.

VMSES/E like SMP/E has its software inventory, which, by default, is stored on minidisks owned by MAINT.

### 9.4.1 Installing COR service

Installing service from a COR tape or other media is very similar to performing a SMP/E RECEIVE/APPLY process before putting to production.

To install COR service:

1. Read the MEMO to Users.
2. Use the VMFREC command to receive the service.
3. Review any messages from VMFREC and correct them.
4. Verify the installation environment.
5. Run VMFAPPLY to apply the service.
6. Review any messages from VMFAPPLY and correct them.
7. Perform any tasks required to build or rebuild the component.
8. Review any messages and correct errors.
9. Test the serviced components and correct any errors.
10. Build any saved segments.
11. Merge the intermediate apply disk with the tested service to production.

All of these tasks, with the exception of reviewing and correcting items, can be performed by using the compound execs SERVICE and PUT2PROD. Figure 9-1 on page 392 shows the COR installation flow taken from *z/VM VMSES/E Introduction and Reference*, GC24-6130.

Steps 1-3 correspond to a SMP/E RECEIVE process; steps 4-6 to the APPLY process; and steps 7-11 include any distribution or other activities you normally perform outside of SMP/E, depending on your procedures. For some z/OS sites, SMP/E ACCEPT can be part of the procedures.

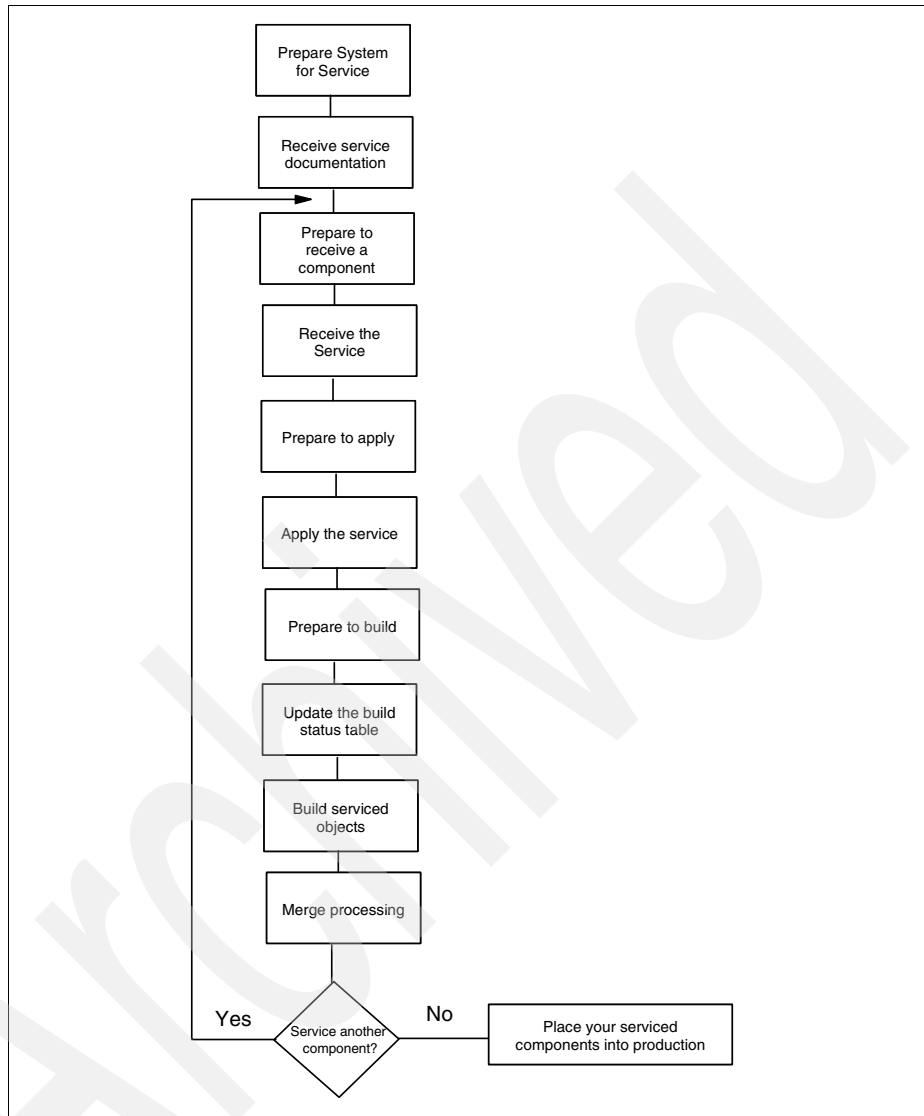

Figure 9-1 COR installation flow, from VMSES/E Introduction and Reference guide

## 9.4.2 Product Service Upgrade (PSU)

This type of maintenance is used for servicing or maintaining your z/VM portfolio to a higher service level; it is not for upgrading. The PSU procedure uses the Recommended Service Upgrade (RSU) media to accomplish this. The media



has a fixed logical structure per product, shown in Figure 9-2, also from the *z/VM VMSES/E Introduction and Reference*, GC24-6130.

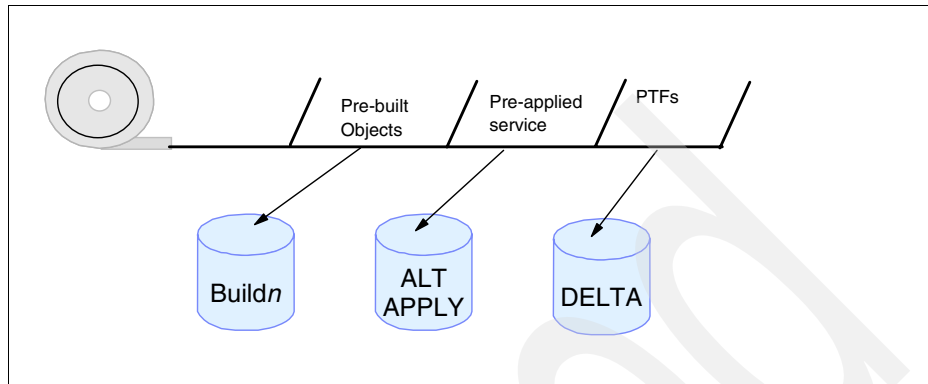

Figure 9-2 Logical file structure of RSU media

The process is performed in the following order:

1. Receive and view documentation for the product.
2. Prepare to receive the product using exec VMFPSU to help you plan.
3. Receive from RSU.
4. Process additional service for the product not included in RSU, including any *local modifications*.
5. Rebuild the product.
6. Repeat the steps for every product until all are completed.

**Note:** Item 4 is similar to reapplying usermods that were REGRESSED by service applied in SMP/E.

Figure 9-3 on page 394 illustrates the RSU installation tasks.

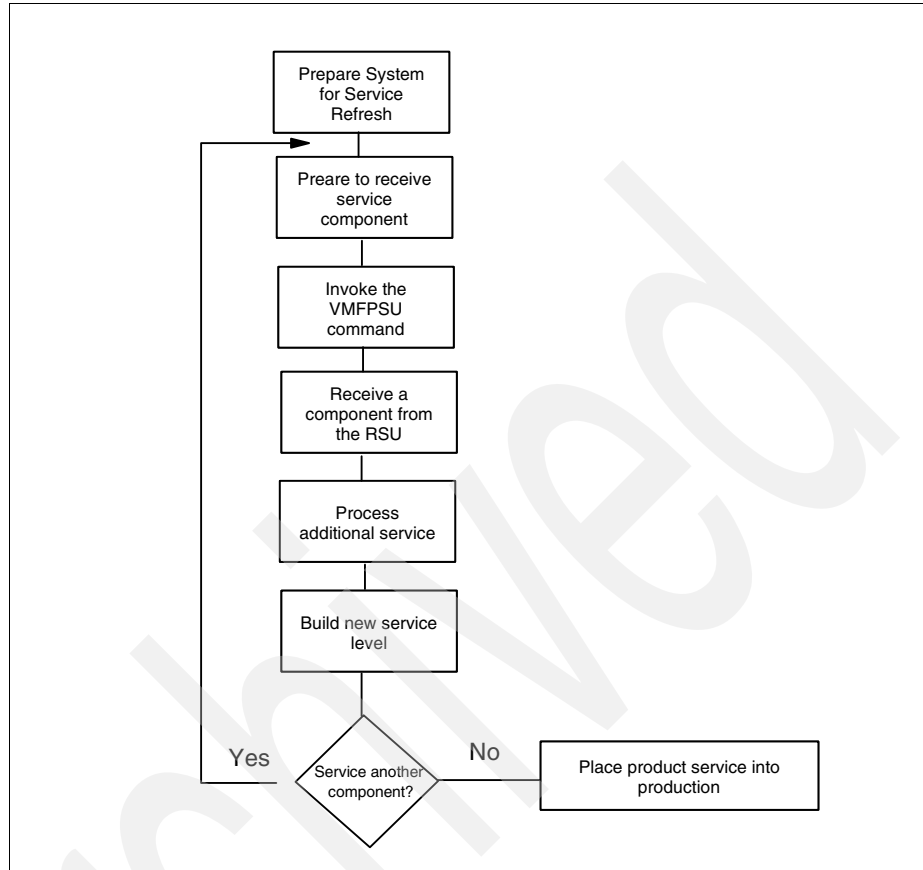

Figure 9-3 PSU installation work flow

## 9.5 Convenient maintenance practices for z/VM

A convenient practice for servicing your z/VM system is to bring up, or clone, a secondary level z/VM for this purpose. From within this clone or copy, you can perform any service activities on that system. That provides a suitable environment for testing before performing identical servicing of your first level system. Many z/VM sites do their servicing in this way. This maintenance environment can be accomplished by installing a new z/VM from a virtual machine defined to your first level z/VM. You can also clone your initial installation, provided a backup copy exists and the disks containing the original installation have been relabelled to avoid potential duplicate volser situations.

For details about installing a secondary z/VM, refer to manual *z/VM: Guide for Automated Installation and Service*, GC24-6099

The scenario for having duplicate labelled disk volumes is further discussed in the following publications:

- ▶ *z/VM and Linux on IBM System z: The Virtualization Cookbook for SLES9*, SG24-6695
- ▶ *IBM z/VM and Linux on IBM System z: Virtualization Cookbook for Red Hat Enterprise Linux 4*, SG24-7272

## 9.6 Case study

During the writing of this book, a second level z/VM was brought up under the primary one. Service was downloaded from the Web, and then we used FTP to put it on MAINT's 500 virtual disk on the system. These downloaded files were *DETERSEd* (decompacted using the DETERSE MODULE) to MAINT's 500 virtual disk, this time having a file type of SERVLINK. You should also verify that these files have a record length of 4005.

**Note:** All of these activities were performed from the MAINT virtual machine.

Example 9-1 shows a terminal display after invoking the DETERSE exec for each of the downloaded files.

*Example 9-1 DETERSE of the downloaded files*

---

```
Ready; T=0.01/0.01 09:28:23
deterse S7820380 SHIPRSU1 H1 53ORSU03 SERVLINK H
Ready; T=2.04/2.15 09:29:42
deterse S7820381 SHIPTFSS H1 53OSERVI SERVLINK H
Ready; T=0.16/0.17 09:30:12
```

---

After having prepared the files, we issued the following commands from the virtual machine for the secondary z/VM, named VMGUEST, after detaching the 500 disk from the primary's MAINT machine:

```
VARY ONLINE 500
ATT 500
ACC 500 h
FILEL * * h
```

**Note:** The **FILEL \* \* h** command displays the DETERSEd files.

Then, we issued the SERVICE command to install the RSU:

```
SERVICE ALL 53ORSU03
```

Example 9-2 and Example 9-3 show the terminal output of the invoked SERVICE exec.

*Example 9-2 Output from SERVICE exec*

---

```
VMFINS2603I Processing product :PPF SERVP2P REXX :PRODID 5VMREX30%REXX
VMFREQ2805I Product :PPF SERVP2P REXX :PRODID 5VMREX30%REXX has passed
requisite
           checking
VMFINT2603I Installing product :PPF SERVP2P REXX :PRODID 5VMREX30%REXX
VMFREC2760I VMFREC processing started
VMFREC1852I Volume 1 of 1 of INS ENVELOPE 5303
VMFREC1851I (1 of 4) VMFRCAXL processing AXLIST
VMFRCX2159I Loading 4 part(s) to DELTA 3D2 (K)
VMFREC1851I (2 of 4) VMFRCPTF processing PARTLST
VMFRCP2159I Loading 1 part(s) to DELTA 3D2 (K)
VMFREC1851I (3 of 4) VMFRCCOM processing DELTA
VMFRCC2159I Loading 3 part(s) to DELTA 3D2 (K)
VMFREC1851I (4 of 4) VMFRCALL processing APPLY
VMFRCA2159I Loading part(s) to APPLY 3A6 (G)
VMFRCA2159I Loaded 5 part(s) to APPLY 3A6 (G)
VMFREC2189I Updating Requisite table 5VMREX30 SRVREQT, Description table
           5VMREX30 SRVDESCT and Receive Status table 5VMREX30 SRVRECS with 1
           new PTFs from INS 5303
```

---

VM READ VMGUEST

---

*Example 9-3 More output from SERVICE exec*

---

```
VMFUTL2205I BUILD9   R    R/W  402  MNT402
VMFUTL2205I BASE2    T    R/W  6B2  MNT6B2
VMFUTL2205I BASE4    U    R/W  3B2  MNT3B2
VMFUTL2205I -----  A    R/W  191  MNT191
VMFUTL2205I -----  B    R/W  5E5  MNT5E5
VMFUTL2205I -----  C    R/W  2CC  MNT2CC
VMFUTL2205I -----  D    R/W  51D  MNT51D
VMFUTL2205I -----  S    R/O  190  MNT190
VMFUTL2205I -----  Y/S  R/O  19E  MNT19E
VMFSET2760I VMFSETUP processing completed successfully
AUTO LOGON ***      BLDNUC  USERS = 14
BLDNUC  : CONNECT= 00:00:01 VIRTCPU= 000:00.03 TOTCPU= 000:00.06
BLDNUC  : LOGOFF AT 09:50:19 EDT FRIDAY 05/23/08 BY MAINT
USER DSC LOGOFF AS BLDNUC  USERS = 13   FORCED BY MAINT
VMFSET2760I VMFSETUP processing started for DETACH GCS
```

```
VMFSET2760I VMFSETUP processing completed successfully
VMFSRV2760I SERVICE processing completed successfully for GCS BUILD
VMFSUT2760I VMFSUFTB processing started
VMFSUT2760I VMFSUFTB processing completed successfully
VMFSRV2760I SERVICE processing completed successfully
Ready; T=28.63/30.61 09:50:31
CMS
```

RUNNING VMGUEST

---

## 9.6.1 Invoking PUT2PROD

After having performed the previous steps, we ran the exec PUT2PROD. We had trouble with one of the PTFs during PUT2PROD processing. We discovered that this particular problem was documented as a known error, also containing the necessary actions to circumvent the problem. After we performed the documented actions, we succeeded running the PUT2PROD exec.

Upon completion, we issued the following command from MAINT:

```
SHUTDOWN REIPL
```

Issuing the command indicated that the CP level was now at a higher RSU level:

```
Q CPLEVEL
```

## 9.6.2 Installing additional PTFs

We then applied the additional PTFs, which were shipped since the RSU was released. They should have been installed using SERVICE prior to PUT2PROD to avoid the first problem we ran into. The installation of these PTFs did not complete successfully. We learned that the 500 virtual device should be in read/write mode (R/W), probably because a temporary build process was using that disk during the SERVICE process. After correcting this, the SERVICE completed successfully and so did PUT2PROD.

**Important:** Apply PTFs *before* using PUT2PROD to avoid errors in PUT2PROD.

Ensure that the 500 virtual device is in R/W mode prior to installing PTFs.

## 9.7 Putting your serviced z/VM into production

After maintaining your z/VM with service, an IPL is required because it could be service to CP.

When convenient, depending on your service hours or other conditions, IPL the system. As with any other operating system, all users, or in this case, all virtual machines, will be shut down. z/VM has the ability to perform a SHUTDOWN REIPL, provided it is issued from a virtual machine having the proper privilege class to do it<sup>1</sup>. Virtual machines that are required to run at all times, can be automatically logged off (AUTOLOG) during IPL.

---

<sup>1</sup> Does not have to be performed from an HMC console as opposed to a z/OS IPL

## Cross reference: z/OS, z/VM, and Linux commands

This appendix provides a cross reference between several z/OS commands and concepts and their z/VM and Linux counterparts. Although not all commands and concepts are listed here, we feel this is a good start for the z/OS system programmer to become more familiar with z/VM and Linux on System z.

For our examples, we refer to SLES10 commands when we have to be specific. We recommend checking your Linux distribution to verify that the commands remain the same.

This appendix contains the following tables:

- ▶ Table A-1 on page 400, Commands for file editing
- ▶ Table A-2 on page 400, General commands
- ▶ Table A-3 on page 401, FTP and TCP/IP commands
- ▶ Table A-4 on page 401, General concepts

Table A-1 Commands for file editing

<b>z/OS-ISPF Edit</b>	<b>z/VM CMS XEDIT</b>	<b>Linux vi</b>	<b>Description</b>
r	“	—	Repeat or copy a line
d	d	dd	Delete a line
cc...cc line command	cc ...cc	:i ,coj	Block copy
mm...mm line command	mm...mm	:i ,jmk	Block move
dd...dd	dd...dd	:i ,jmk	Block delete
find <xxxx>	/<xxxx>	/<xxxx>	Find keyword (below)
find <xxxx> prev	-/<xxxx>	?<xxxx>	Find keyword (above)
ex xxx	—	—	Exclude lines containing a character string (xxx)
del all excluded	—	—	Delete the lines that you excluded using the command “ex xxx”
))n line command	—	—	Indent n spaces to the right
((n line command	—	—	Move n spaces to the left

Table A-2 General commands

<b>z/OS command</b>	<b>z/VM command</b>	<b>Linux command</b>	<b>Description</b>
d u,,b120,1	q b120	ls -la /dev/<device>	Display a single device named b120 (replace b120 with your device)
d u,,b120,8	q b120-b127	ls -la /dev/<sd*>	Display string of devices
v b120,online	vary on b120	mount /dev/<device> <mnt_point>	Vary on a device
v b120,offline	vary off b120	umount mnt_point	Vary off a device
—	q paths b120	—	Display paths to a device
—	q chpid 18	—	Display devices on a chpid
D M=CPU	q proc	cat /proc/cpuinfo	Display number of processors



Table A-3 FTP and TCP/IP commands

<b>z/OS commands</b>	<b>z/VM commands</b>	<b>Linux commands</b>	<b>Description</b>
FTP hostname {port}	FTP hostname {port} For a list of options, enter: FTP ?	ftp hostname <-P port>	Connect to remote host to get or put files. Defaults to port 21.
HOMETEST	HOMETEST	ping <gateway ip address>	Validate TCP/IP configuration.
NETSTAT option {TCP procname}	NETSTAT option	netstat	Display network status of local host. For list of options, enter: ?

Table A-4 General concepts

<b>z/OS</b>	<b>z/VM</b>	<b>Linux</b>
IPL(initial program load)	IPL(initial program load)	boot
Nucleus	Control Program (CP)	kernel
HELP command	HELP command	man command
Data set SYS1.UADS	user directory	user registry
TSO or ISPF edit	XEDIT	vi
TSO or ISPF	Conversational Monitor System (CMS)	shell

Archived

# Planning worksheet

Fill in this worksheet to store the values you plan to use for your z/VM and Linux installation on System z.

*Table B-1 Reader's resources worksheet*

Name	Value	Comment
LPAR name		
CPC name		
z/VM system name		
TCP/IP host name		
TCP/IP domain name		
TCP/IP gateway		
DNS server 1		
DNS server 2/3 (optional)		
OSA device name		
OSA starting device number		
TCP/IP address		

Name	Value	Comment
Subnet mask		
OSA device type		
Network type		
Port name (optional)		
Router type		
Primary OSA device number for VSWITCH		
Secondary OSA device number for VSWITCH		
DASD addresses for z/VM		
DASD addresses for Linux		
DASD addresses for paging		

# Related publications

The publications listed in this section are considered particularly suitable for a more detailed discussion of the topics covered in this book.

## IBM Redbooks

For information about ordering these publications, see “How to get Redbooks” on page 408. Note that some of the documents referenced here might be available in softcopy only.

- ▶ *Introduction to the New Mainframe: z/VM Basics*, SG24-7316
- ▶ *Linux Handbook A Guide to IBM Linux Solutions and Resources*, SG24-7000
- ▶ *Linux on IBM System z: Performance Measurement and Tuning*, SG24-6926-01
- ▶ *Security on z/VM*, SG24-7471
- ▶ *z/VM and Linux on IBM System z: The Virtualization Cookbook for SLES 10*, SG24-7493

## Other publications

These publications are also relevant as further information sources:

- ▶ *EREP V3R5 User's Guide*, GC35-0151
- ▶ *Linux on IBM System z: Performance Measurement and Tuning*, SG24-6926
- ▶ *Linux on System z: Using the Dump Tools*, SC33-8412
- ▶ *System z Hardware Management Console Operations Guide*, SC28-6867
- ▶ *z/OS: MVS Initialization and Tuning Reference*, SA22-7592
- ▶ *z/OS V1R9.0 Planning for Installation*, GA22-7504-17
- ▶ *z/VM: CMS Commands and Utilities Reference*, SC24-6073
- ▶ *z/VM: CMS File Pool Planning, Administration, and Operation*, SC24-6074
- ▶ *z/VM: CMS Planning and Administration*, SC24-6078
- ▶ *z/VM: CMS User's Guide*, SC24-6079

- ▶ *z/VM: CP Commands and Utilities Reference*, SC24-6081
- ▶ *z/VM: CP Planning and Administration*, SC24-6083
- ▶ *z/VM: General Information*, GC24-6095
- ▶ *z/VM: Getting Started with Linux on System z*, SC24-6096
- ▶ *z/VM: Guide for Automated Installation and Service*, GC24-6099
- ▶ *z/VM: System Operation*, SC24-6121
- ▶ *z/VM: V5R3.0 CP Messages and Codes*, GC24-6119
- ▶ *z/VM: V5R3.0 Diagnosis Guide*, GC24-6092
- ▶ *z/VM: V5R3.0 System Operation*, SC24-6121
- ▶ *z/VM: Virtual Machine Operation*, SC24-6128
- ▶ *z/VM: VMSES/E Introduction and Reference*, GC24-6130
- ▶ *z/VM: XEDIT User's Guide*, SC24-6132

## Online resources

These Web sites are also relevant as further information sources:

- ▶ z/VM library  
<http://www.vm.ibm.com/library/>
- ▶ *VM and the VM Community: Past, Present, and Future*, Melinda Varian, SHARE 89 Sessions 9059–61, 1997  
<http://www.princeton.edu/~melinda/25paper.pdf>
- ▶ Memory planning
  - IBM z/VM Performance Resource pages:  
<http://www.vm.ibm.com/perf/>
  - Configuring Processor Storage:  
<http://www.vm.ibm.com/perf/tips/storconf.html>
- ▶ Logical Volume Management (LVM)
  - *LVM HOWTO*:  
<http://tldp.org/HOWTO/LVM-HOWTO/>
  - Disk performance optimizing:  
[http://www.ibm.com/developerworks/linux/linux390/perf/tuning\\_rec\\_dasd\\_optimizedisk.html](http://www.ibm.com/developerworks/linux/linux390/perf/tuning_rec_dasd_optimizedisk.html)

- Volume management:  
[http://www.ibm.com/developerworks/linux/linux390/perf/tuning\\_rec\\_dasd\\_volMan.html](http://www.ibm.com/developerworks/linux/linux390/perf/tuning_rec_dasd_volMan.html)
- ▶ Linux references from IBM
  - Ten great reasons to run Linux as a guest of z/VM:  
<http://www.vm.ibm.com/linux/benefits.html>
  - IBM Linux Technology Center (LTC):  
<http://oss.software.ibm.com/linux>
  - IBM developerWorks navigation for Linux on System z:  
<http://www-03.ibm.com/systems/z/os/linux/>  
<http://oss.software.ibm.com/developerworks/opensource/linux390/index.shtml>
  - Linux on IBM System z:  
<http://www.vm.ibm.com/linux/>  
<http://www.ibm.com/servers/eserver/zseries/os/linux/>
- ▶ Linux references from other sources
  - IBM: Security Benefits of Red Hat Enterprise Linux 5 on IBM System z:  
[http://www.redhat.com/f/pdf/rhel/security\\_rhe15.pdf](http://www.redhat.com/f/pdf/rhel/security_rhe15.pdf)
  - Gentoo Linux handbook:  
<http://www.gentoo.org/doc/en/handbook/index.xml>
  - The crontab file:  
<http://www.linuxdoc.org>
  - Shell scripting tutorials:  
[http://en.wikipedia.org/wiki/Shell\\_script](http://en.wikipedia.org/wiki/Shell_script)
- ▶ Distributions available for System z
  - Novell SUSE Linux Enterprise Server (SLES) for System z; Kernel 2.6.16:  
<http://www.novell.com/partners/ibm/mainframe/>
  - Red Hat Enterprise Linux (RHEL) 5, Kernel 2.6.18:  
<http://www.redhat.com/rhel/server/mainframe/>
  - Debian for S/390 and zSeries; Debian Etch, Kernel 2.6.18:  
<http://www.us.debian.org/ports/s390/>
  - Build your own by downloading the kernel from:  
<http://www.kernel.org>

- ▶ Setting up Apache:  
<http://www.apache.org/>
- ▶ Virtualization:  
<http://www-03.ibm.com/systems/z/advantages/virtualization/index.html>

## How to get Redbooks

You can search for, view, or download Redbooks, Redpapers, Technotes, draft publications and Additional materials, as well as order hardcopy Redbooks, at this Web site:

[ibm.com/redbooks](http://ibm.com/redbooks)

## Help from IBM

IBM Support and downloads

[ibm.com/support](http://ibm.com/support)

IBM Global Services

[ibm.com/services](http://ibm.com/services)



# Index

## Numerics

2048M userid 334  
2084XA 0BE34E 364  
3270 emulators 161  
3390/OC 3990/E9 303  
520RES 154  
530RES one 153  
530RES volume 165

## A

A disc 76, 126, 129–130  
abbreviating commands 72  
abend 352  
    critical, CP terminates 353  
    soft 352  
ACTive command 325  
alloc 327–328  
Alt+Tab sequence 146  
application retrieve 334  
Asynchronous Transfer Mode (ATM) 44  
ATTACH command 152  
authorized program analysis report (APAR) 389  
AUTO LOGON 233, 396

## B

background processing 114  
backward compatibility 11, 261  
base control program (BCP) 320  
basic mode 13  
batch folder 277  
batch job 177, 227, 257, 274, 276, 363, 389–390  
byte file system (BFS) 22  
    CMS record files 22

## C

cache usage, port utilization in CPU 255  
Capacity for Planned Event (CPE) 100  
Capacity on Demand (COD) 100  
case-sensitive commands 72  
CBPDO delivery 123  
central processor complex (CPC) 51, 143  
channel-to-channel (CTC) 7, 243

channel-to-channel adapters (CTCA) 243  
chmod command 113–114  
class G 71  
    define CPU 316  
    user 71–72, 288  
clean start 234, 237  
clearing the screen 63  
CMS batch facility  
    machine 276–277  
    virtual machine 276  
CMS command 22, 26  
    environment 57  
    format 72  
    Help 36  
    SENDFILE 40, 267  
CMS environment 40–41, 57, 249  
CMS file 29, 74, 77, 270, 272, 274, 294, 297  
CMS NSS 250  
CMS user 26, 72, 75, 127, 133, 295–296  
cold start 234, 237  
color of directory contents 105  
command format, XEDIT 80  
command line 35, 44, 54, 60  
    area 65  
    BACKWARD and FORWARD subcommands 85  
    BACKWARD, FORWARD commands 85  
    CP mode 66  
    current SET TABS subcommand 88  
    interface 66  
    LOGON command 60  
command mode, in vi editor 115  
configuration file 87, 92, 101, 126–128, 157, 286, 289  
Configure KDM 216  
Control Program (CP) 9, 14, 127, 138, 284, 320–321, 352, 390, 401  
Conversational Monitor System (CMS) 9, 14, 19–21, 125, 238, 339, 401  
COPYFILE command 75–76, 90, 126, 173  
CP command 42, 72, 137, 236, 240, 250, 289, 293  
    environment 57  
    group 324  
    not case-sensitive 57

- QUERY USERID 68
- SPXTAPE 379
- CP Monitor 324, 334
- CP Planning 52, 290, 293
- CP READ 55, 57
- cp set 176, 324
  - PF11 188, 197
  - signal shutdown 180 176, 197
- CP SET SRM command 333
- CP SPOOL
  - console close 359
  - console start 357
- CPACCESS command 174
- CPC Recovery 145
  - LOAD icon 170
- cpdisk 172
- CPSYNTAX 181
- CPSYNTAX command 174
- CPU 01 194, 251, 255, 315–316
  - store status 212

## D

- DASD
  - 3390 online 134
  - activating in a SLES10 install 202–203
  - address 144, 260, 404
  - console log 360
  - formatting in SLES10 install 203
  - lists for backup 376
  - managing multiples 307
  - pack 70, 259
  - real address 260
  - rebuild ramdisk 305
  - restore from tape to 377
  - virtual address 191 19
  - volume 19, 134, 169, 225, 237, 258, 327, 330
  - volume setup 127
- DASD pack 259
- DDR Volume 376
- delivery
  - CBPDO 123
  - ServerPac 122
  - SystemPac 123
- device driver 7–8, 302, 344
- device number 243
  - 8FF 264
  - 9FF 263
  - card minimum 138

- CP query names 331
  - load by 235
  - lowest 124
  - OSA Express cards 138
  - OSA starting 144, 403
  - primary OSA 404
  - real I/O 325
- DFSMS/VM 21, 27
- Direct Access Storage Device. *See* DASD
- DIRECTXA command 186, 222, 225, 297–298
- DirMaint 28
- DISABLE HCD 290
- Disconnect Timeout 172–173
- discontiguous saved segment (DCSS) 235, 344–345
- Discretionary Access Control (DAC) 288
- disk label 137, 187, 263
- DISKMAP command 184
- DK8228 8228 240
- DMSACP723I F 130, 132
- DMSFOR603R Format 137, 187, 263
- DNS server
  - 1 143, 160, 403
  - 2/3 143, 403
  - TCP/IP address 139
- domain name server (DNS) 97
- duplicate volume
  - label 165
  - name 165
- Dynamic Host Configuration Protocol (DHCP) 97

## E

- edit mode, XEDIT 81
- editing session 79–80, 82–83, 88, 90
  - current changes 80
  - system malfunctions 90
- EDT THURSDAY 06/05/08 233, 361
- Environmental Record Editing and Printing 356
- error message 137, 354
  - COPYFILE command 76
  - device error 186
  - getting help 36, 43, 354
  - Linux error codes 355
  - maximum storage size 258
  - no overlapping minidisks 185
  - SET MSG OFF command 229
- existing CP command

- new alias 289
- new version 289
- Expanded Service Option (ESO) 389
- external security manager (ESM) 4, 228, 285

## F

- Features statement 173
- file mode 22, 73, 129–130
  - R/W disk 75
  - Z 132, 187
  - Z b 132, 168
- file mode Z 162
- file name 22, 73–74, 126–127, 129, 269
- file system 22, 96–97, 101, 127, 129, 132, 141, 272, 291, 302, 304, 345
- File Transfer Protocol (FTP) 96
- FILE2 Script 89
- FILELIST command 73–74, 125–126
  - abbreviated form 137
- Filemode Y 162, 175
- filepool 272–274
- Filesystem Hierarchy Standard (FHS) 101
- first DVD 189
- first level 17, 101
  - CP 252
  - virtual machine 253
- FORCE start 170
- force start 234, 237
- FORMAT command 187
- format, XEDIT commands 80
- formatting option 36, 39
- full-screen CMS 39
- full-screen mode 57, 229, 338

## G

- GCS component 26, 31
- Grant access 175, 197
- graphical user interface (GUI) 25–26
- Group Control System (GCS) 20, 24
- guest operating system 3, 19, 21, 35, 47, 139, 177, 183, 219, 248–249, 253, 286, 295, 336, 345, 366
  - base product 21
  - guest profile 197
  - guest system defined 54
  - levels 17
  - managing 248
  - share data 22
  - shutdown signals 246

- z/OS guests 121
- guest system 21, 246
- guest user 69
  - Id 221, 225
  - ID SC59 222
- virtual machine 69

## H

- Hardware Management 50–52, 123, 145, 148
- Hardware Management Console (HMC) 51, 121, 398
- HCPIVM8392I INSTVM 156
- HELP
  - command in CMS 36
  - HCP053E 355
  - in z/OS, z/VM, Linux 401
  - XEDIT Menu 93
- HELP command 36
- Help levels in CMS 39
- HiperSockets 44–46, 48
- HMC 145
  - CD-ROM/DVD 148
  - level 145–146
  - Load icon 153
  - Operating System Messages 164
  - Single Object Operations 146
  - SYSG 154
  - System Console (SYSC) 164
- Hypervisor technology 13

## I

- I/O configuration task 25
- I/O device 3, 14, 18, 225, 247, 266, 334
- I/O Subsystem 247, 362, 365
- in-depth (ID) 22
- initial program load (IPL) 15, 123, 227, 229, 388, 390, 401
- initial ramdisk 304–305
- input file
  - format 376
  - management 74
- input mode, XEDIT 81
- input or output (I/O) 14–16, 325
- INSTPLAN 151
- INSTVM EXEC 156
- integer number 275, 325
- Integrated 3270 51–52, 123, 145, 154, 166
- Integrated Facility for Linux (IFL) 7, 99, 138, 194,

239  
 Interactive Problem Control System (IPCS) 24  
 interface eth0 314  
 internal Queued Direct Input/Output (IQDIO) 46  
 Inter-User Communication Vehicle (IUCV) 7  
 INUSE 328  
 invalid password 286  
 IP address 139  
   reset 369  
   takeover 311  
 IPL CMS 156, 250  
   defining in USER DIRECT 19  
 IPL section 305  
 IPL time 161, 163, 289, 294, 356  
   notautolog parameter 163  
 IPWIZARD 143, 158  
 ISPF editor 79–81, 124  
   line command 84  
   primary command 87–88

**J**

job control language (JCL) 363, 378  
 Job Entry Subsystem (JES) 267, 275–276, 320  
 Job scheduling 274–275  
 job, in background 114

**L**

Language Environment (LE) 20, 25  
 last line 59  
 layers (levels) of help in CMS 39  
 LIC 46  
 Licensed Internal Code (LIC) 46  
 Line printer router (LPR) 32  
 Linux 23, 47, 95, 121, 283–284, 288, 319–320, 351  
 Linux distribution 97, 138–139, 218, 308, 381, 399  
 Linux error  
   code 355  
   handling 355  
 Linux guest 7, 141–142, 144, 301, 309, 337, 367  
   Cached pages 343  
   capacity requirements 341  
   environment 192  
   IBM z/VM Planner 341  
   IPLs 302  
   LNXCER 192–193  
   machine 189, 191  
   memory requirements 343  
   modeled workload 341  
   monitoring task 345  
   Performance monitoring 345  
   profile 189, 197  
   profound implications 343  
   reasons one 372  
   Sizing considerations 343  
   storage 345  
   system 172, 177, 183, 192  
   user 181, 192–193  
   virtual machine 163  
   virtual machine size 337  
   virtual memory size 337  
   z/VM Planner 341  
 Linux image 6–7, 98, 141, 279, 344  
   Disk storage 141  
   other ones 203  
 Linux kernel 8, 149, 171, 189, 191, 302–303, 355  
 Linux performance  
   bandwidth capabilities 47  
   data 30, 338  
   gatherer 30  
 Linux system 6, 36, 166, 192, 212, 214–215, 275, 289, 307, 337, 348, 386  
   administrator 140  
   call 72  
   level 142  
   LVM 195  
   open source profiler 348  
 Linux Technology Center (LTC) 5  
 Linux workload  
   capacity 8  
   environment 341  
 LNXCER Pun 200  
 LNXDFLT profile 194  
 LNXMAINT 183  
 Load icon 153  
 log file 317, 359  
   correct number of files 372  
 logical CPUs 254  
 logical partition (LPAR) 25, 47, 100, 121, 238–239, 286, 341  
   defined 13  
   mode in mainframes 13  
 logical volume 209–210, 307, 385  
   exact copy 385  
 Logical Volume Manager (LVM) 195  
 login screen 60, 155, 216  
 logmsg data 125, 132, 233, 361  
 LPAR

- creating 13
- requirements 138
- LPAR mode 13
- LPARNAME 224
- LVM 195
- LVM2 snapshot 385
- LX6PAG 1A22 171, 182, 240

## M

- MACH XA 135, 299
- MAINT user
  - directory 379
  - id 149, 197
- major number 302
- Mandatory Access Control (MAC) 288
- MCH Detail Report (MDR) 362
- MDISK statement 184
- member name 381–382
- messages, displaying emergency 52
- minidisk level 272
- multi-read (MR) mode 135, 167, 172

## N

- Named Saved System (NSS) 235, 249–250
- network interface 301, 309, 368
  - card 301, 313
- network job entry (NJE) 32
- next IPL 170, 197, 234, 304

## O

- Open Systems Adapter (OSA) 20, 26, 138
  - Express2 26
  - Support Facility 20, 26
- operating system (OS) 2, 96, 123, 139, 231–232, 235, 248, 286, 320, 336, 366, 386
  - basic concepts 13
  - command language 56
  - new release 2
- OSA adapter 44, 219
- OSA card 140, 144, 159–160
- OSA device
  - name 143, 403
  - type 144, 404
- OSA/SF 26
- overcommit memory 175
- overlaps, searching for 185

## P

- PA1 key 252–253
- page cache 345
- paging device 240, 380
- partitioning
  - basic 13
  - z/VM guest 13
- passwords planning 140
- pattern xxx 119
- performance monitoring 8, 29, 338
- Performance Tool Kit 325
- pf12 ret 175, 197
- physically connected (PC) 50, 274, 338, 340
- power input mode 89
- powertyping mode 89
- prefix area 78–79, 81, 185
  - characters SI 83
  - double character DD 82
  - double character MM 85
  - prefix subcommands 79
- prefix subcommand 81, 83–85
  - Data manipulation 81
- privilege class 18, 70–71, 235, 285, 287, 388, 398
  - A-G 287–288
  - ANY 288
- Product Service Upgrade (PSU) 392
- production environment 2, 5, 13, 17, 142, 280
- production system 6, 50–51, 53, 165, 248, 280
- PROFILE EXEC 55, 62, 126, 188, 222, 269, 358
  - backup copy 162
  - LNXMAINT's 188
- PROFILE Exec 126
- PROFILE LNXDFLT 194
- PROFILE XEDIT 91–92, 126, 128, 157–158, 162
  - Copy 125, 149
  - file 92
- PRT 66, 70, 125, 132, 233, 357–358
- PTFs 390, 397
- PUT2PROD command 156

## Q

- QUERY ALLOC
  - Page 240
  - PAGE command 182
  - SPOOL command 240
  - TDISK 241
- Queued Direct I/O (QDIO) 46, 335

## R

RAM storage 69  
ramdisk image 191  
RDR 66, 70, 125, 132, 233, 359  
reader queue 267, 269, 271  
read-write access 173  
real DASD 259  
    multiple types 260  
    pack 259, 261–262  
    pack address 265  
real machine 2, 16, 35, 56, 287  
    abnormal termination 2  
real storage 3, 34, 238, 256, 287, 330, 332, 366  
Recommended Service Upgrade (RSU) 124, 153, 389, 392  
RECS 0006 380  
Red Hat Enterprise Linux 288  
Redbooks Web site 408  
    Contact us xiii  
rel f 174  
RELEASE command 174  
remote job entry (RJE) 32  
Remote Spooling Communications Subsystem (RSCS) 21, 31, 276  
    GCS component 31  
Resource Access Control Facility (RACF) 21, 30, 291  
Resource Management Facility (RMF) 30, 338  
return code 157, 355  
REXX/VM 20, 26  
REXX/VM Interpreter 26  
    single source base 26  
root password 213  
RSCS network 32  
running z/VM system  
    hot backup 379  
running z/VM system hot backup 379

## S

same time 2, 13–14, 68, 132, 344, 388  
    different directories 132  
    host computer 13  
    peak utilization 341  
SAPL screen 52  
saved segments  
    rebuilding 171  
screen clearing 63  
second level

CP 252  
    z/VM system 252, 395  
Secure Sockets Layer (SSL) 4, 284  
SENDFILE command 267  
ServerPac delivery 122  
service virtual machine 247  
SET VSWITCH GRANT command 197  
SFS directory 90  
Shared File System (SFS) 22, 163, 248, 272, 291  
SHUTDOWN command 165, 176, 234  
    z/VM system 236  
SHUTDOWN REIPL 157, 165, 236, 397–398  
Simple Mail Transfer Protocol (SMTP) 97  
Single Object Operations 146  
single System z 6  
    server 7  
    server platform 48  
SLES10  
    activating DASD in an install 202–203  
    formatting DASD in an install 203  
    partitioning DASD in an install 205  
small programming enhancement (SPE) 389  
SMTP Server 164  
SNA network 24  
    non-VM systems 23–24  
snapshot device 385  
spool data 267  
spool device 248, 266, 268  
spool file 232, 235, 266, 268  
    saving console log 357  
    spooling operator 287  
SSH connection 201  
stand-alone program loader (SAPL) 52, 154  
starts  
    clean 234, 237  
    cold 234, 237  
    force 234, 237  
    warm 237  
status area 57, 158  
storage RAM 69  
SUSE Linux  
    Enterprise Server 97  
    Enterprise Server 10 369  
    version 10 372  
    version 9 371  
suspend job to background 114  
SYSG 154  
system administrator 9, 35, 69, 71, 101, 140, 255–256, 259, 261, 285, 385

SYSTEM CONFIG file 52, 126–127, 166–167, 174,  
231–232, 246, 289, 357, 366, 388

Features statement 173

System Console (SYSC) 164

System event 351

Collecting information 356

system maintenance 3, 274, 280, 387, 389

system operator 25, 29, 51–52, 228, 242, 244, 287,  
338, 356, 362, 367

system programmer 277, 287–288, 324, 338

system resource 5, 31, 237, 287, 291, 321–322,  
324

efficient use 338

total amount 337

System Resource Manager (SRM) 332–333

system startup 165, 175

System z 1, 4–6, 14–15, 26, 33, 44, 95–96, 123,  
138, 142, 248, 280, 283, 320, 336, 351, 378

Linux installation 403

virtual servers 46–47

SystemPac delivery 123

Systems Network Architecture (SNA) 23–24

## T

T3390 argument, to DEFINE command 262

target DASD 123

TCP FTPSERVE 164

TCP INTCLIEN 164

TCP SMTP 164

TCP/IP address 139–140, 144, 403

TCP/IP communication 46

TCP/IP gateway 139, 143, 403

TCP/IP network 25, 32, 48–49, 161, 244

TCPCMSU 184

TCPIP user 128–129, 163, 244

TDISK 241, 259, 263

allocation 262

total 328

TDISK allocation 262

TDISK Total 328

TELNET Server 164

TERM command 63–64

terminology, DASD and minidisk 259

thrashing 337

time-of-day (TOD) 232–233

timeout 63

Transparent Services Access Facility (TSAF) 20,  
24, 26

triplet 73, 130, 138

TSO/ISPF user 73, 390

## U

UNASSIGNED RDEV 176

Unsolicited File Transfer (UFT) 32

user class restructure (UCR) 235

user definition 18, 135, 193, 195, 292, 295

USER DIRECT 18–19, 126–127, 134–135, 168,  
220, 265

INCLUDE statement 193

profile 193

source formats 294

source version 294

system volumes 169

z/OS guest 225

z/VM guest definition 19

user directory 186, 232, 248, 256, 293, 295, 360,  
379, 401

DEDICATE statement 44

user ZOS1 18

USER DISKMAP file 135, 185, 296, 300

user ID 26, 30, 68, 145, 149, 155, 158, 271, 273,  
284, 354

access 184, 197

common interface 162, 187

CP classes 19

MAINT 289

user MVSOPR1 230

user space 36, 74, 97, 130, 177, 368

user VMUSER1 229

User\_Volume\_Include 181

User\_Volume\_List 181

## V

VDISK 172–173, 177, 259, 261, 344

allocation 264

vi editor 115–116, 128

virtual device 35, 70, 243, 254, 261, 266, 397

address 70

number 70, 249, 260, 262, 264, 359

number 000C 268

number, managing CPUs 254

virtual disk. *See* VDISK

virtual machine 2, 262, 283, 285, 319, 352

available almost limitless spare systems 6

command environment 57

command language 56

- configuration 127, 243
- Control Program 14
- crash 11
- definition 295
- directory entry 255, 257
- dump 24
- environment 2, 7, 57
- guest 69
- high-performance communication 7
- IPLs 358
- IPLs CMS 129
- management 8
- operator 53–54
- password 284
- printer 359
- production systems 53
- resource usage 324
- separate commands 224
- session 60–61
- size 142, 337, 344
- supervisor 24
- SVC76 command 362
- system 285, 291
- underlying principles 16
- user 14, 56, 69
- user ID 269, 284
- user name 269
- virtual CPUs 254
- virtual reader 359, 366
- Virtual Memory Area (VMA) 350
- virtual NIC 194
- virtual processor 67, 286
- virtual switch. *See* VSWITCH
- Virtual Telecommunications Access Method (VTAM) 20
- Virtualization Technology 10
- virtualized environment 343–344
- VM READ 57, 125, 155
  - status 277
  - VMGUEST 396
- VM system 2–3, 7–9, 13, 24, 27, 352, 356
  - APPC/VM programs 27
  - other APPC/VM programs 27
- VMSES/E 27, 390–391, 393
- VNC client 201, 214
- VNC viewer 139
- VOLID Read 380
- volume group 209–210, 308
  - logical volume 309
  - remaining space 210
- volume label 124, 165, 260–261
- volume LX6RES 232–233, 328–329
- volume LX6W02 184, 300
- VSWITCH 44, 128, 144, 163, 172, 174–175, 290
  - controller 49, 176
  - controllers 1 and 2 175, 197
  - statement 290, 301
- VTAM SNA Console Support (VSCS) 24

**W**

- warm start 234, 237
- wide-area information server (WAIS) 96
- Workload Manager (WLM) 320
- workload use 337

**X**

- XAREPMC Record 363
- XAUTOLOG command 163
- XEDIT
  - "" prefix command 193
  - ADD subcommand 174
  - BOTTOM subcommand 174
  - edit mode 81
  - FILE subcommand 174
  - input mode 81
  - power input mode 89
  - powertyping mode 89
  - PREFIX OFF subcommand 185
  - PROFILE 157
  - S disk 76
  - session 126, 162

**Y**

- YaST installation 202, 211, 213

**Z**

- z/OS analogy 18, 127, 254, 390
  - all 87
  - APPC/VM VTAM Support (AVS) 24
  - AUTOLOG1 user tasks 129
  - Autosave 90
  - AVS 24
  - Backup Linux 378
  - Backup z/VM 379
  - CMS 36
  - CMS Files 22



- Copying a file to a new file 77
- Copying lines 85
- CP 21
- CP INDICATE 324
- CP INDICATE PAGING 326
- CP QUERY ALLOC 327
- CP QUERY CPLOAD 329
- CP QUERY FRAMES 330
- CP QUERY NAMES 331
- CP QUERY STOR 333
- CP QUERY SYSTEM 333
- D U,,ALLOC 333
- Delete 82
- DFSMS/VM 27
- Dump Viewing Facility (DVF) 24
- dumps 367
- EDIT profile 93
- EREP 363
- Exit without saving 91
- Exiting help 93
- FILEList (FILEL) 73
- Filename 74
- HCD and HCM for z/VM 25
- HELP 36
- IEASYSxx, CP SET MAXUSERS 334
- Inserting a line using XEDIT 82
- Inserting external files 88
- Language Environment (LE) 26
- Move blocks of lines 85
- Navigating the HELP menu 44
- OSA/SF 26
- Performance Toolkit for z/VM 30
- Power typing 89
- Prefix subcommands 79
- Privilege classes 71
- Query 68
- QUERY CPLEVEL 68
- QUERY SRM 333
- QUERY USERID 68
- RACF for z/VM 31
- Recovering lines 83
- Repeating lines 84
- REXX/VM 26
- RSCS 32
- Scheduler and dispatcher 34
- SEND command 228
- shell 96
- SHUTDOWN 235
- SMP/E 390
- status line 80
- SYSLOG 360
- System Clear 67
- TCP/IP 23
- Up and Down 86
- USER DIRECT 18
- XEDIT 78
  - XEDIT prefix subcommands 81
- z/OS guest 54, 121, 140, 220, 225, 246
- z/OS hint 259, 262
- z/OS image 2, 16, 33, 122–123, 219, 320
- z/OS system 9, 121, 219, 293, 331, 388
  - IPL 219, 223
  - log 226
  - programmer 95
- z/OS user 51, 67, 124, 126, 228, 249, 276
- z/VM
  - basic commands 65
  - cons=sysg 155
  - DIRECTXA command 186
  - Disconnect Timeout 172
  - DISKMAP command 184
  - FORMAT command 187
  - INSTPLAN EXEC 151
  - INSTVM EXEC 156
  - IPWIZARD command 158
  - PUT2PROD command 156
  - RELEASE command 174
  - shutting down 165
  - stand-alone program loader 154
- z/VM CP 53
- z/VM CPACCESS command 174
- z/VM guest 13, 140, 219, 224, 251–252, 341, 343
- z/VM IPL 129
  - process 232
  - time 196
- z/VM operating system (z/OS) 13, 17, 69, 121, 319
- z/VM site 122, 389, 394
- z/VM system 4, 9, 15–17, 122, 140, 143, 230, 236, 246, 269, 284–285, 320, 324, 356, 366, 387
  - Network connectivity 44
  - Performance management 324
  - TCP/IP address 144, 159
  - various recordings 356
- z/VM user 53, 55, 125, 128, 130, 227–228, 287
- z/VM version 5.3
  - checking disk link and map 132
  - CMS 125
  - console log file 359

CP mode 66  
installation media 139, 145  
IPL 190 249  
IPL CMS 250  
IPL process 233  
LNXMaint console output 361  
LOGON MAINT 125, 132



## **z/VM and Linux Operations for z/OS System Programmers**

(0.5" spine)  
0.475" <-> 0.875"  
250 <-> 459 pages







# z/VM and Linux Operations for z/OS System Programmers



**An introduction to  
z/VM and Linux for  
z/OS programmers**

This IBM Redbooks publication discusses z/VM and Linux operations from the perspective of the z/OS programmer or system programmer. Although other books have been written about many of these topics, this book gives enough information about each topic to describe z/VM and Linux on IBM System z operations to somebody who is new to both environments.

**Migrate z/OS to a  
z/VM guest system**

This book is intended for z/OS programmers and system programmers who are transitioning to the z/VM and Linux on System z environments and who want a translation guide for assistance.

**Install and manage  
Linux on System z**

We base this book on our experiences using System z10 Enterprise Edition, z/VM version 5.3 RSU 0701, and Novell SUSE Linux Enterprise Server (SLES) 10 on System z.

**INTERNATIONAL  
TECHNICAL  
SUPPORT  
ORGANIZATION**

**BUILDING TECHNICAL  
INFORMATION BASED ON  
PRACTICAL EXPERIENCE**

IBM Redbooks are developed by the IBM International Technical Support Organization. Experts from IBM, Customers and Partners from around the world create timely technical information based on realistic scenarios. Specific recommendations are provided to help you implement IT solutions more effectively in your environment.

**For more information:**  
[ibm.com/redbooks](http://ibm.com/redbooks)