

1

2

## 3 Contributor group

Belliardi, Rudy <rudy.belliardi@schneider-electric.com>

Dorr, Josef <josef.dorr@siemens.com>

Enzinger, Thomas <thomas.enzinger@inchstone.com>

Farkas, János <janos.farkas@ericsson.com>

Hantel, Mark <mrhantel@ra.rockwell.com>

Riegel, Maximilian <maximilian.riegel@nokia.com>

Stanica, Marius-Petru <marius-petru.stanica@de.abb.com>

Steindl, Guenter <guenter.steindl@siemens.com>

Wamßer, Reiner <Reiner.Wamsser@boschrexroth.de>

Zuponic , Steven A. <szuponic@ra.rockwell.com>

4

## 5 Abstract

6 This document describes use cases for industrial automation, which have to be covered by the  
7 joint IEC/IEEE TSN-IA Profile for Industrial Automation.

8

9

10

11

12

## 13 Log

V0.1-V0.3

working drafts

V0.4

2018-03-02

Revised after circuit meeting

V0.5

2018-03-07

Revised and presented during Chicago meeting

V0.6

2018-04-12

Elaborated additional use cases from Chicago

Added new use cases:

- Control loops with bounded latency
- Drives without common application cycle but common network cycle
- Redundant networks
- Vast number of connected stations
- Digital twin

---

		Presented at ad-hoc meeting Munich
V0.61	2018-04-30	Revised after Munich ad-hoc review <ul style="list-style-type: none"><li>- Added Interoperability clause (2.1)</li><li>- Reworked industrial automation traffic patterns clause (2.3.1)</li><li>- Added VLAN requirements clause (2.4.11.1)</li><li>- Added private machine domains sub-clause (2.5.2)</li></ul>
V0.7	2018-06-09	Comment resolution Interim Pittsburgh May 2018
V1.0	2018-07-20	Added Plenary San Diego July 2018 contributions and comments: <ul style="list-style-type: none"><li>- TSN domain definition</li><li>- control loop clause</li></ul>

14  
15

## 16 Content

17	Contributor group .....	1
18	Abstract .....	1
19	Log.....	1
20	Content.....	3
21	Figures.....	4
22	Tables.....	6
23	1 Terms and Definitions .....	7
24	1.1 Definitions.....	7
25	1.2 IEEE802 terms.....	8
26	2 TSN in Industrial Automation .....	9
27	2.1 Interoperability .....	10
28	2.2 TSN Domain .....	11
29	2.3 Synchronization .....	12
30	2.3.1 General.....	12
31	2.3.2 Universal Time Synchronization.....	12
32	2.3.3 Working Clock Synchronization .....	13
33	2.3.4 Use case 01: Sequence of events.....	14
34	2.4 Industrial automation mode of operation .....	14
35	2.4.1 Industrial automation traffic types.....	14
36	2.4.1.1 General.....	14
37	2.4.1.2 Characterization of isochronous cyclic real-time and cyclic real-time .....	16
38	2.4.2 Control Loop Basic Model.....	17
39	2.4.3 Use case 02: Control Loops with guaranteed low latency .....	18
40	2.4.3.1 Isochronous cyclic operation model .....	21
41	2.4.3.2 Delay requirements.....	23
42	2.4.4 Use case 03: Control Loops with bounded latency.....	25
43	2.4.4.1 Cyclic operation model .....	26
44	2.4.4.2 Cyclic traffic pattern .....	27
45	2.4.5 Use case 04: Reduction ratio of network cycle.....	28
46	2.4.6 Use case 05: Drives without common application cycle .....	29
47	2.4.6.1 Background information.....	29
48	2.4.6.2 Controller communication .....	30
49	2.4.6.3 Timing Requirements.....	31
50	2.4.7 Use case 06: Drives without common application cycle but common network cycle	31
51	2.5 Industrial automation networks .....	33
52	2.5.1 Use case 07: Redundant networks .....	33
53	2.5.2 Use case 08: High Availability.....	33
54	2.5.3 Use case 09: Wireless .....	34
55	2.5.4 Use case 10: 10 Mbit/s end-stations (Ethernet sensors) .....	35
56	2.5.5 Use case 11: Fieldbus gateway .....	36
57	2.5.6 Use case 12: New machine with brownfield devices .....	37
58	2.5.7 Use case 13: Mixed link speeds.....	37
59	2.5.8 Use case 14: Multiple isochronous domains .....	39
60	2.5.9 Use case 15: Auto domain protection .....	40
61	2.5.10 Use case 16: Vast number of connected stations .....	41
62	2.5.11 Minimum required quantities.....	42
63	2.5.11.1 A representative example for VLAN requirements .....	42
64	2.5.11.2 A representative example for data flow requirements .....	44
65	2.5.11.3 A representative example of communication use cases.....	45

66	2.5.11.4	“Fast” process applications .....	45
67	2.5.11.5	Server consolidation .....	46
68	2.5.11.6	Direct client access.....	47
69	2.5.11.7	Field devices.....	47
70	2.5.12	Bridge Resources .....	48
71	2.6	Industrial automation machines, production cells, production lines .....	51
72	2.6.1	Use case 17: Machine to Machine/Controller to Controller (M2M/C2C) Communication.....	51
73			
74	2.6.2	Use case 18: Pass-through Traffic.....	53
75	2.6.3	Use case 19: Modular machine assembly.....	54
76	2.6.4	Use case 20: Tool changer .....	55
77	2.6.5	Use case 21: Dynamic plugging and unplugging of machines (subnets).....	56
78	2.6.6	Use case 22: Energy Saving.....	57
79	2.6.7	Use case 23: Add machine, production cell or production line .....	57
80	2.6.8	Use case 24: Multiple applications in a station using the TSN-IA profile .....	58
81	2.6.9	Use case 25: Functional safety .....	58
82	2.7	DCS Reconfiguration .....	59
83	2.7.1	Challenges of DCS Reconfiguration Use Cases .....	59
84	2.7.2	Use case 26: DCS Device level reconfiguration.....	59
85	2.7.3	Use case 27: DSC System level reconfiguration .....	60
86	2.8	Further Industrial Automation Use Cases.....	61
87	2.8.1	Use case 28: Network monitoring and diagnostics.....	61
88	2.8.2	Use case 29: Security.....	61
89	2.8.3	Use case 30: Firmware update .....	62
90	2.8.4	Use case 31: Virtualization .....	62
91	2.8.5	Use case 32: Digital twin.....	64
92	2.8.6	Use case 33: Device replacement without engineering.....	64
93	3	Literature .....	64
94			
95			

## 96 Figures

97	Figure 1 – Hierarchical structure of industrial automation.....	9
98	Figure 2 – Principle of interoperation.....	11
99	Figure 3 – Scope of work .....	11
100	Figure 4 – TSN Domains.....	12
101	Figure 5 – plant wide time synchronization.....	13
102	Figure 6 – line/cell/machine wide working clock synchronization overlapping with a universal time domain.....	13
103		
104	Figure 7 – Principle data flow of control loop.....	18
105	Figure 8 – network cycle and isochronous application (Basic model).....	19
106	Figure 9 – Multiple concurrent isochronous control loops (Extended model).....	19
107	Figure 10 – Variation 1: two cycle timing model .....	20
108	Figure 11 – Variation 2: two cycle timing model - shifted by 180°.....	20
109	Figure 12 – Variation 3: three cycle timing model.....	20
110	Figure 13 – Variation 4: one cycle timing model.....	20
111	Figure 14 – Variation 5: one cycle timing model – changed sequence .....	21
112	Figure 15 – Variation 6: further optimizations .....	21
113	Figure 16 – isochronous cyclic operation model.....	21
114	Figure 17 – delay measurement reference points .....	24
115	Figure 18 – network cycle and non-isochronous application (Basic model).....	25

116	Figure 18 – cyclic operation model.....	26
117	Figure 19 – network cycle and application cycle.....	28
118	Figure 20 – network with different application cycles.....	29
119	Figure 21 – isochronous drive synchronization .....	30
120	Figure 22 – Multivendor Motion – Controller communication.....	30
121	Figure 23 – Multivendor Motion – Timing Requirements .....	31
122	Figure 24 – different application cycles but common network cycle.....	32
123	Figure 25 – ring topology .....	33
124	Figure 26 – connection of rings .....	33
125	Figure 27 – example topology for tunnel control.....	34
126	Figure 28 – HMI wireless connected using cyclic real-time .....	35
127	Figure 29 – Remote IO wireless connected using cyclic real-time.....	35
128	Figure 30 – Ring segment wireless connected for media redundancy.....	35
129	Figure 31 – Ethernet sensors.....	36
130	Figure 32 – fieldbus gateways.....	36
131	Figure 33 – new machine with brownfield devices.....	37
132	Figure 34 – mixed link speeds.....	38
133	Figure 35 – mixed link speeds without topology guideline .....	38
134	Figure 36 – multiple isochronous domains .....	39
135	Figure 37 – multiple isochronous domains - coupled.....	40
136	Figure 38 – auto domain protection.....	40
137	Figure 39 – Topologies, trees and VLANs.....	43
138	Figure 40 – Logical communication concept for fast process applications.....	46
139	Figure 41 – Server consolidated logical connectivity .....	46
140	Figure 42 – Clients logical connectivity view .....	47
141	Figure 43 – Field devices with 10Mbit/s .....	48
142	Figure 44 – M2M/C2C between TSN domains .....	51
143	Figure 45 – M2M with supervisory PLC.....	52
144	Figure 46 – M2M with four machines .....	52
145	Figure 47 – M2M with diagnostics/monitoring PC.....	52
146	Figure 48 – pass-through one machine.....	53
147	Figure 49 – pass-through one machine and production cell .....	53
148	Figure 50 – pass-through two machines .....	54
149	Figure 51 – machine with diagnostics / monitoring PC .....	54
150	Figure 52 – modular bread-machine .....	55
151	Figure 53 – modular advertisement feeder.....	55
152	Figure 54 – tool changer .....	56
153	Figure 55 – AGV plug and unplug .....	56
154	Figure 56 – energy saving.....	57
155	Figure 57 – add machine .....	58
156	Figure 58 – two applications .....	58
157	Figure 59 – Functional safety with cyclic real-time .....	59
158	Figure 60 – Device level reconfiguration use cases .....	60
159	Figure 61 – System level reconfiguration use cases .....	61
160	Figure 62 – Ethernet interconnect with VM based vBridge.....	63
161	Figure 63 – Ethernet interconnect with PCIe connected Bridge.....	63
162		
163		
164		
165		

166 **Tables**

167	Table 1 – Industrial automation traffic types summary .....	15
168	Table 2 – isochronous cyclic real-time and cyclic real-time traffic type properties .....	16
169	Table 3 – Application types .....	18
170	Table 4 – isochronous traffic pattern properties .....	23
171	Table 5 – Expected PHY delays.....	24
172	Table 6 – Expected MAC delays .....	24
173	Table 7 – Expected Ethernet Bridge delays .....	25
174	Table 8 – cyclic traffic pattern properties .....	27
175	Table 9 – Link speeds.....	37
176	Table 10 – Expected number of stream FDB entries.....	44
177	Table 11 – Expected number of non-stream FDB entries.....	44
178	Table 12 – Neighborhood for hashed entries .....	44
179	Table 13 – MinimumFrameMemory for 100 Mbit/s (50%@1 ms).....	49
180	Table 14 – MinimumFrameMemory for 1 Gbit/s (20%@1 ms).....	49
181	Table 15 – MinimumFrameMemory for 2,5 Gbit/s (10%@1 ms).....	49
182	Table 16 – MinimumFrameMemory for 10 Gbit/s (5%@1 ms).....	50

## 183 1 Terms and Definitions

## 184 1.1 Definitions

Reconfiguration	<ul style="list-style-type: none"> <li>- Any intentional modification of the system structure or of the device-level content, including updates of any type</li> <li>- Ref: IEC 61158- Type 10, dynamic reconfiguration</li> <li>- Document to be provided by PI/PNO: Guidelines for high-availability</li> </ul>
(Process) disturbance	<ul style="list-style-type: none"> <li>- Any malfunction or stall of a process/machine, which is followed by production loss or by an unacceptable degradation of production quality</li> <li>- Ref: IEC 61158 – Failure</li> <li>- Ref. ODVA: Unplanned downtime</li> <li>- Document to be provided by PI/PNO: Guidelines for diagnosis</li> </ul>
Operational _state of a plant (unit)/machine	Normal state of function and production of a plant(unit)/machine
Maintenance _state of a plant (unit)/machine	Planned suspension or partial suspension of the normal state of function of a plant(unit)/machine
Stopped _state of a plant (unit)/machine	Full non-productive mode of a plant(unit)/machine
Convergent network concept	All Ethernet-based devices are able to exchange data over a common infrastructure, within defined QoS parameters
Device	End station, bridged end station, bridge
DCS	Distributed Control System
Transmission selection algorithms	A set of algorithms for traffic selection which include Strict Priority, the Credit-based shaper and Enhanced Transmission Selection. <sup>1)</sup>
Preemption	The suspension of the transmission of a preemptable frame to allow one or more express frames to be transmitted before transmission of the preemptable frame is resumed. <sup>1)</sup>
Enhancements for scheduled traffic	A Bridge or end station may support enhancements that allow transmission from each queue to be scheduled relative to a known timescale. <sup>1)</sup>
Time-Sensitive Stream	A stream of traffic, transmitted from a single source station, destined for one or more destination stations, where the traffic is sensitive to timely delivery, and in particular, requires transmission latency to be bounded. <sup>1)</sup>
TSN domain	A quantity of commonly managed industrial automation devices; A set of stations (end stations and/or Bridges), their Ports, and the attached individual LANs that transmit Time-Sensitive Streams using TSN standards which include Transmission Selection Algorithms,

---

<sup>1</sup> taken from 802.1Q-2018

	Preemption, Time Synchronization and Enhancements for Scheduled Traffic and that share a common management mechanism. It is an administrative decision to group these devices (see 2.2).
universal time domain	gPTP domain used for the synchronization of universal time
working clock domain	gPTP domain used for the synchronization of a working clock
isochronous domain	stations of a common working clock domain with a common setup for the isochronous cyclic real-time traffic type
cyclic real-time domain	stations with a common setup for the cyclic real-time traffic type - even from different working clock domains
Network cycle	transfer time including safety margin, and application time including safety margin (see Figure 8); values are specific to a TSN domain and specifies a repetitive behavior of the network interfaces belonging to that TSN domain;
Greenfield	for the context of this document: greenfield refers to TSN-IA profile conformant devices; regardless if "old" or "new";
Brownfield	for the context of this document: brownfield refers to devices, which are not conformant to the TSN-IA profile; regardless if "old" or "new";

## 185 1.2 IEEE802 terms

Priority regeneration	See IEEE 802.1Q-2014 clause 6.9.4 Regenerating priority
Ingress rate limiting	See IEEE 802.1Q-2014 clause 8.6.5 Flow classification and metering

186

187

188



189  
190

## 2 TSN in Industrial Automation

191

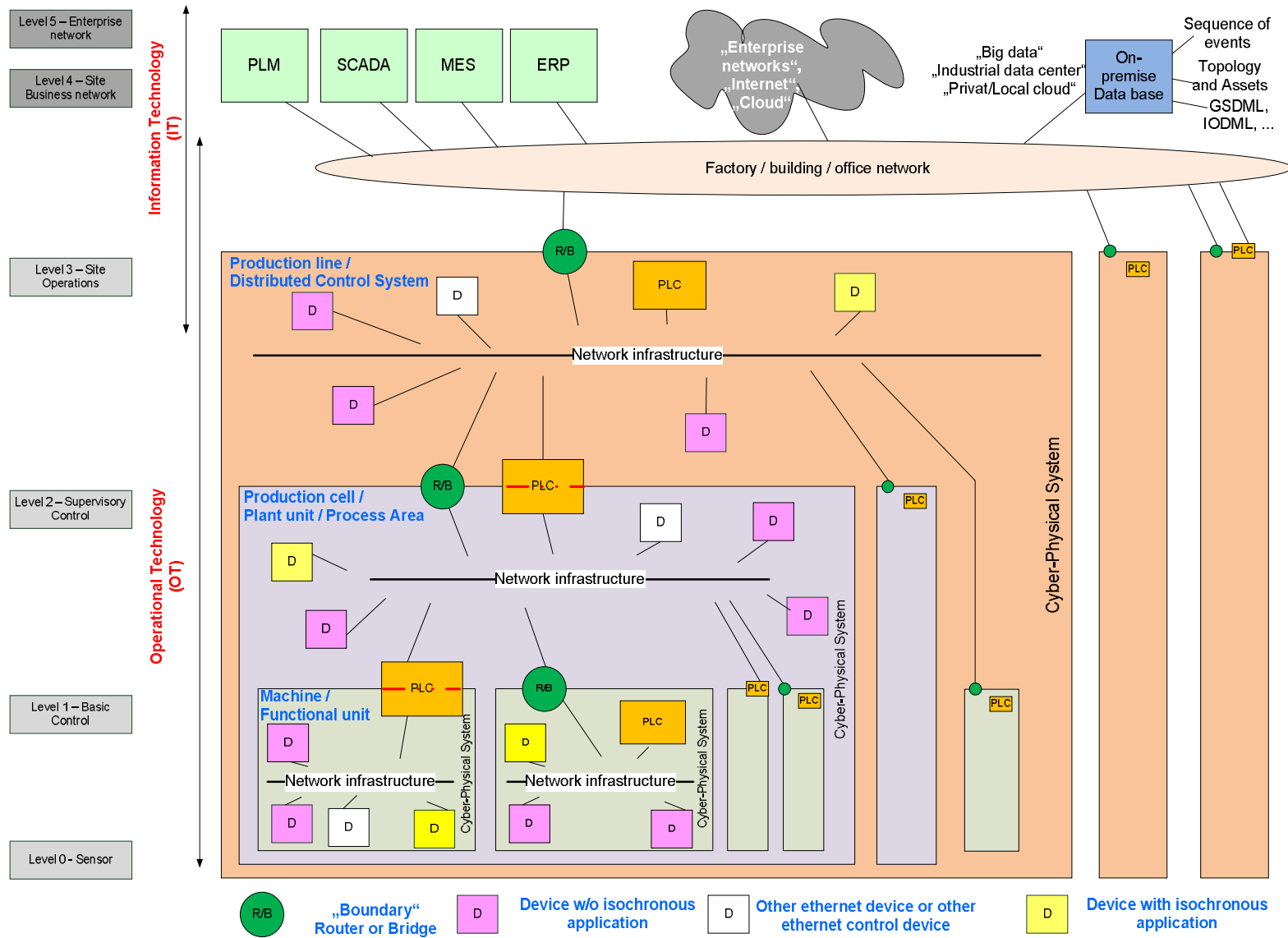

Figure 1 – Hierarchical structure of industrial automation

192  
193

194 There is no generally accepted definition of the term “Cyber-Physical System (CPS)”. A report of  
195 Edward A. Lee [1] suitably introduces CPS as follows: „*Cyber-Physical Systems (CPS) are*  
196 *integrations of computation with physical processes. Embedded computers and networks monitor*  
197 *and control the physical processes, usually with feedback loops where physical processes affect*  
198 *computations and vice versa.*”  
199

200 Cyber-Physical Systems are the building blocks of “smart factories” and Industry 4.0. Ethernet  
201 provides the mechanisms (e.g. TSN features) for connectivity to time critical industrial applications  
202 on converged networks in operational technology control levels.

203 Ethernet with TSN features can be used in Industrial Automation for:

- 204 · Real-time (RT) Communication within Cyber-Physical Systems
- 205 · Real-time (RT) Communication between Cyber-Physical Systems

206

207 A CPS consists of:

- 208 ○ Controlling devices (typically 1 PLC),
- 209 ○ I/O Devices (sensors, actors),
- 210 ○ Drives,
- 211 ○ HMI (typically 1),
- 212 ○ Interface to the upper level with:
  - 213 - PLC (acting as gateway), and/or
  - 214 - Router, and/or
  - 215 - Bridge.
- 216 ○ Other Ethernet devices:
  - 217 - Servers or any other computers, be it physical or virtualized,
  - 218 - Diagnostic equipment,
  - 219 - Network connectivity equipment.
  - 220

## 221 2.1 Interoperability

222 Interoperability may be achieved on different levels. Figure 2 and Figure 3 show three areas, which  
223 need to be covered:

- 224 - network configuration (managed objects according to IEEE definitions), and
- 225 - stream configuration and establishment, and
- 226 - application configuration.

227 The three areas mutually affect each other (see Figure 2).

228 Application configuration is not expected to be part of the profile, but the two other areas are.

229 The selection made by the TSN-IA profile covers Ethernet defined layer 2 and the selected  
230 protocols to configure layer 2.

231 Applications make use of upper layers as well, but these are out of scope for the profile.

232 Stream establishment is initiated by applications to allow data exchange between applications. The  
233 applications are the source of requirements, which shall be fulfilled by network configuration and  
234 stream configuration and establishment.

235

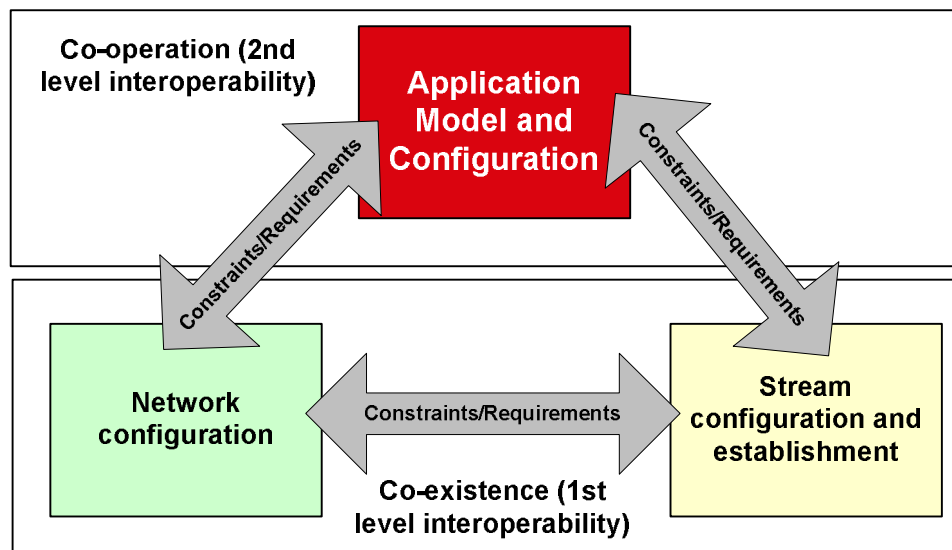

Figure 2 – Principle of interoperation

236  
237  
238

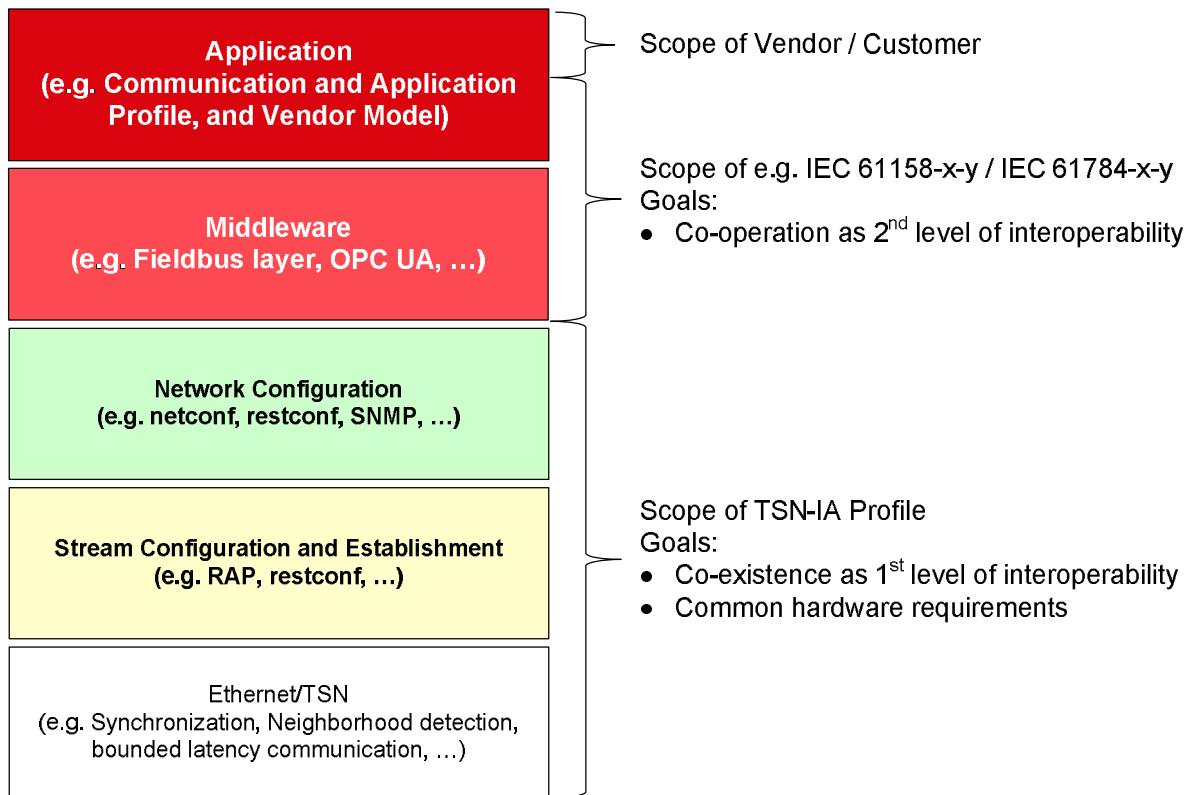

Figure 3 – Scope of work

239  
240  
241

## 242 2.2 TSN Domain

243 A TSN domain is defined as a quantity of commonly managed industrial automation devices; it is  
244 an administrative decision to group these devices.

245 TSN Domain Characteristics:

- 246 . One or more TSN Domains may exist within a single layer 2 broadcast domain.
- 247 . A TSN Domain may not be shared among multiple layer 2 broadcast domains.
- 248 . Multiple TSN Domains may share a common universal time domain.
- 249 . Two adjacent TSN Domains may implement the same requirements but stay separate.

250 Typically machines/functional units (see Figure 1) constitute separate TSN domains. Production  
 251 cells and lines may be set up as TSN domains as well. Devices may be members of multiple TSN  
 252 domains in parallel.

253 Interrelations between TSN domains are described in 2.6.1.

254 Figure 4 shows two example TSN domains within a common broadcast domain and a common  
 255 universal time domain. TSN domain 1 is a pure cyclic real-time domain, whereas TSN domain 2  
 256 additionally includes three overlapping isochronous domains.  
 257

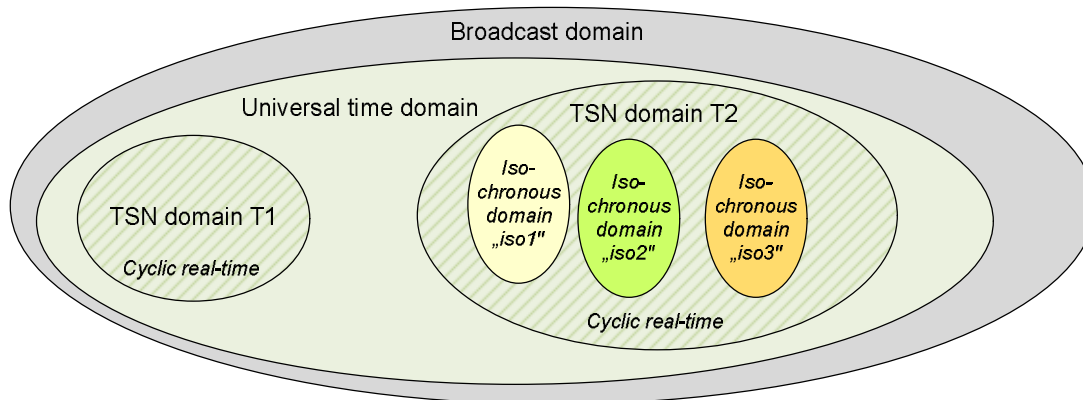

258  
 259 **Figure 4 – TSN Domains**  
 260

## 261 2.3 Synchronization

### 262 2.3.1 General

263 Synchronization covering both universal time (wall clock) and working clock is needed for industrial  
 264 automation systems.

265 Redundancy for synchronization of universal time may be solved with “cold standby”. Support of  
 266 "Hot standby" for universal time synchronization is not current practice - but may optionally be  
 267 supported.

268 Redundancy for working Clock synchronization can be solved with “cold standby” or “hot standby”  
 269 depending on the application requirements. Support of "hot standby" for working clock  
 270 synchronization is current practice.

271 More details about redundancy switchover scenarios are provided in:

272 <http://www.ieee802.org/1/files/public/docs2018/60802-Steindl-TimelinessUseCases-0718-v01.pdf>.

### 273 2.3.2 Universal Time Synchronization

274 Universal time is used to plant wide align events and actions (e.g. for “sequence of events”). The  
 275 assigned timescale is TAI, which can be converted into local date and time if necessary. Figure 5  
 276 shows the principle structure of time synchronization with the goal to establish a worldwide aligned  
 277 timescale for time. Thus, often satellites are used as source of the time.

278

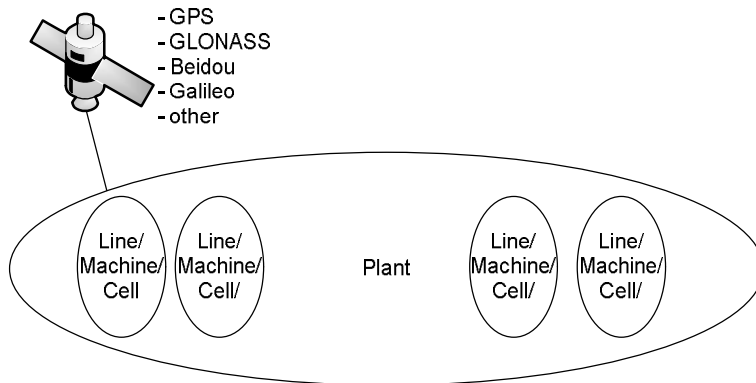

279

280

**Figure 5 – plant wide time synchronization**

281 Note: “Global Time” or “Wall Clock” are often used as synonym terms for “Universal Time”.

282 **2.3.3 Working Clock Synchronization**

283 Working Clock is used to align actions line, cell or machine wide. The assigned timescale is  
 284 arbitrary. Robots, motion control, numeric control and any kind of clocked / isochronous application  
 285 rely on this timescale to make sure that actions are precisely interwoven as needed. Figure 6  
 286 shows the principle structure of Working Clock synchronization with the goal to establish a line /  
 287 cell / machine wide aligned timescale. Thus, often PLCs, Motion Controller or Numeric Controller  
 288 are used as Working Clock source.

289 If multiple PLCs, Motion Controller or Numeric Controller need to share one Working Clock  
 290 timescale, an all-time active station must be used as Working Clock source, also known as  
 291 Grandmaster.

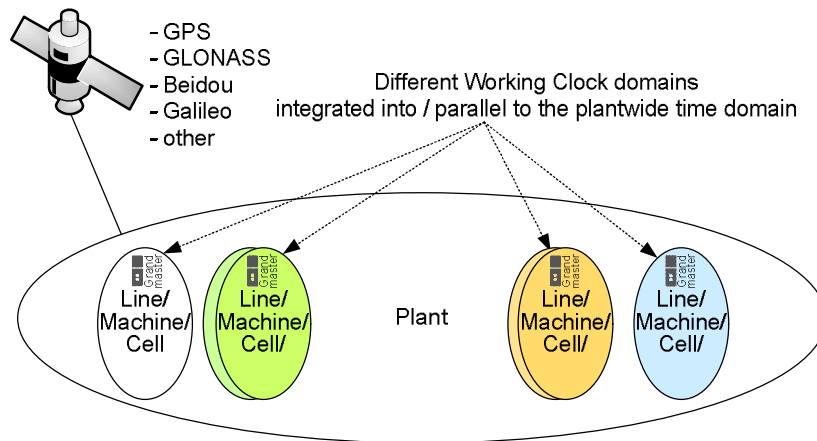

292

**Figure 6 – line/cell/machine wide working clock synchronization overlapping with a universal time domain**

293

294

295 Working Clock domains may be doubled to support zero failover time for synchronization.

296 High precision working clock synchronization is a prerequisite for control loop implementations with  
 297 low latency (see 2.4.2).

298

299  
300  
301  
302  
303  
304  
305  
306  
307

#### Requirements:

- High precision working clock synchronization;
- Maximum deviation to the grandmaster time in the range from 100 ns to 1  $\mu$ s;
- Support of redundant sync masters and domains;
- Zero failover time in case of redundant working clock domains;

#### Useful 802.1 mechanisms:

- IEEE 802.1AS-Rev

308  
309  
310  
311  
312  
313  
314  
315  
316  
317

#### 2.3.4 Use case 01: Sequence of events

Sequence of events (SOE) is a mechanism to record timestamped events from all over a plant in a common database (on-premise database in Figure 1).

Application defined events are e.g. changes of digital input signal values. Additional data may be provided together with the events, e.g. universal time sync state and grandmaster, working clock domain and value ...

SOE enables root-cause analysis of disruptions after multiple events have occurred. Therefore SOE can be used as diagnostics mechanism to minimize plant downtime.

Plant-wide precisely synchronized time (see Figure 5) is a precondition for effective SOE application.

318

SOE support may even be legally demanded e.g. for power generation applications.

319

#### Requirements:

320  
321  
322  
323

- Plant wide high precision Universal Time synchronization;
- Maximum deviation to the grandmaster time in the range from 1  $\mu$ s to 100  $\mu$ s;
- Optional support of redundant sync masters and domains;
- Non-zero failover time in case of redundant universal time domains;

324  
325

#### Useful 802.1 mechanisms:

326  
327

- IEEE 802.1AS-Rev

328

## 2.4 Industrial automation mode of operation

329

### 2.4.1 Industrial automation traffic types

330

#### 2.4.1.1 General

331  
332  
333  
334  
335  
336

Industrial automation applications concurrently make use of different traffic schemes/patterns for different functionalities, e.g. parameterization, control, alarming. The various traffic patterns have different characteristics and thus impose different requirements on a TSN network.

Table 1 subsumes the industrial automation relevant traffic patterns to traffic types with their associated properties (see also: <http://www.ieee802.org/1/files/public/docs2018/new-Bruckner-LNI-traffic-patterns-for-TSN-0118.pdf>).

Table 1 – Industrial automation traffic types summary

Traffic type name	Periodic/ Sporadic	Guarantee	Data size	Redundancy	Details
isochronous cyclic real-time	P	deadline/ bounded latency (e.g. 20% @ 1 Gbit/s / 50% @ 100 Mbit/s network cycle)/ bandwidth	bounded	up to seamless <sup>1)</sup>	see Table 4 and 2.4.2
cyclic real-time	P	deadline/ bounded latency (e.g. n-times network cycle)/ bandwidth	bounded	up to seamless <sup>1)</sup>	see Table 8 and 2.4.4
network control	S	Priority	-	up to seamless <sup>1)</sup> as required	see 2.3 and 2.5.1
audio/video	P	bounded latency/ bandwidth	bounded	up to regular <sup>2)</sup>	-
brownfield	P	bounded latency/ bandwidth	-	up to regular <sup>2)</sup>	see 2.5.6
alarms/ events	S	bounded latency/ bandwidth	-	up to regular <sup>2)</sup>	see 2.3.4
configuration/ diagnostics	S	Bandwidth	-	up to regular <sup>2)</sup>	see 2.8.1
Internal / Pass-through	S	Bandwidth	-	up to regular <sup>2)</sup>	see 2.6.2
best effort	S	-	-	up to regular <sup>2)</sup>	-

338

339 <sup>1)</sup> almost zero failover time340 <sup>2)</sup> larger failover time because of network re-convergence

341

342 All traffic types of Table 1 are referenced by the use cases, which are described in this document:

343

344 Isochronous:

345

à see *Use case 02: Control Loops with guaranteed low latency*

346

347 Cyclic:

348

à see *Use case 03: Control Loops with bounded latency*

349

350 Network control:

351

à see *Use case 07: Redundant networks*

352

353 Audio/video:

354

à NOTE: Non-AVB – need to follow TSN-IA profile rules!

- 355 - Machine vision applications: counting, sorting, quality control, video surveillance,  
 356 augmented reality, motion guidance, ...  
 357 - based on TSN features and stream establishment, and not on AVB...  
 358

359 Brownfield:

360     à see *Use case 12: New machine with brownfield devices*

361

362 Alarms/events:

363     à see *Use case 01: Sequence of events*

364

365 Configuration/diagnostics:

366     à see *Use case 28: Network monitoring and diagnostics*

367

368 Internal:

369     à see *Use case 18: Pass-through Traffic*

370 Best effort:

371     à see ...

#### 372 [2.4.1.2 Characterization of isochronous cyclic real-time and cyclic real-time](#)

373 The following properties table is used to characterize in detail the traffic types of Use case 02:  
 374 Control Loops with guaranteed low latency and Use case 03: Control Loops with bounded latency.

375 **Table 2 – isochronous cyclic real-time and cyclic real-time traffic type properties**

Property	Description
Data transmission scheme	<i>Periodic (P)</i> - e.g. every N $\mu$ s, or <i>Sporadic (S)</i> - e.g. event-driven
Data transmission constraints	Indicates the traffic pattern's data transmission constraints for proper operation. Four data transmission constraints are defined: <ul style="list-style-type: none"> <li>• <i>deadline</i>: transmitted data is guaranteed to be received at the destination(s) before a specific instant of time,</li> <li>• <i>latency</i>: transmitted data is guaranteed to be received at the destination(s) within a specific period of time after the data is transmitted by the sending application,</li> <li>• <i>bandwidth</i>: transmitted data is guaranteed to be received at the destination(s) if the bandwidth usage is within the resources reserved by the transmitting applications,</li> <li>• <i>none</i>: no special data transmission constraint is given.</li> </ul>
Data period	For traffic types that transmit <i>periodic</i> data this property denotes according to the <i>data transmission constraints</i> : <ul style="list-style-type: none"> <li><i>deadline</i>: application data deadline period,</li> <li><i>latency, bandwidth</i> or <i>none</i>: data transmission period.</li> </ul> The period is given as a <i>range</i> of time values, e.g. 1 $\mu$ s ... 1ms. For the <i>sporadic</i> traffic types, this property does not apply.
Data transmission synchronized to network cycle	Indicates whether the data transmission of sender stations is synchronized to the network cycle. Available property options are: <i>yes</i> or <i>no</i> .



Property	Description
Application synchronized to working clock	Indicates whether the applications, which make use of this traffic pattern, are synchronized to the working clock. Available property options are: <i>yes</i> or <i>no</i> .
Acceptable jitter	Indicates for traffic types, which apply data transmission with <i>latency</i> constraints, the amount of jitter, which can occur and must be coped with by the receiving destination(s). For traffic types with <i>deadline</i> , <i>bandwidth</i> or <i>none</i> data transmission constraints this property is not applicable ( <i>n.a.</i> ).
Acceptable frame loss	Indicates the traffic pattern's tolerance to lost frames given e.g. as acceptable frame loss ratio range. The frame loss ratio value <i>0</i> indicates traffic types, where no single frame loss is acceptable.
Payload	Indicates the payload data <i>type</i> and <i>size</i> to be transmitted. Two payload types are defined: <ul style="list-style-type: none"> <li>• <i>fixed</i>: the payload is always transmitted with exactly the same size</li> <li>• <i>bounded</i>: the payload is always transmitted with a size, which does not exceed a given maximum; the maximum may be the maximum Ethernet payload size (1500).</li> </ul>

## 376 2.4.2 Control Loop Basic Model

377 **Control loops** are fundamental building blocks of industrial automation systems. Control loops include:  
378 process sensors, a controller function, and output signals. Control loops may require guaranteed low  
379 latency or more relaxed bounded latency (see 2.4.4) network transfer quality.

380 To achieve the needed quality for Control loops the roundtrip delay (sometimes called makespan,  
381 too) of the exchanged data is essential.

382 Figure 7 shows the whole transmission path from Controller application to Device application(s)  
383 and back. The blue and red arrows show the contributions to the e2e (end-to-end) latency  
384 respectively.

385  
386 Figure 7 and Table 3 show three levels of a control loop:

- 387 § Application - within Talker/Listener,
- 388 § Network Access - within Talker/Listener,
- 389 § Network Forwarding - within Bridges.

390 Network Access is always synchronized to a working clock.

391 Application may or may not be synchronized to the synchronized Network Access depending on  
392 the application requirements. Applications which are synchronized to Network Access are called  
393 "isochronous applications". Applications which are not synchronized to Network Access are called  
394 "non-isochronous applications".

395 Network Forwarding may or may not be synchronized to a working clock depending on whether the  
396 Enhancements for Scheduled Traffic (802.1Qbv) are applied.

397

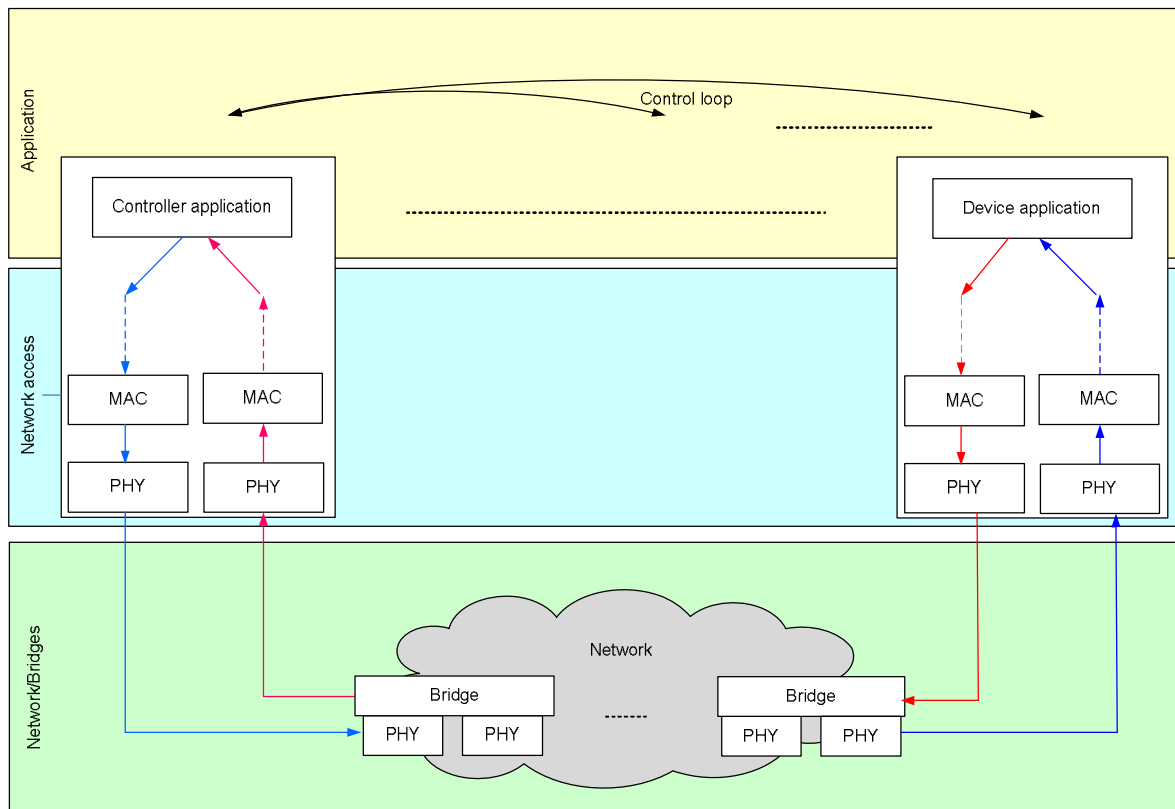

398  
399 **Figure 7 – Principle data flow of control loop**

400  
401 **Table 3 – Application types**

Level	Isochronous Application		Non-isochronous Application	
Application	Synchronized to network access		Free running	
Network access	Synchronized to working clock			
Network/Bridges	Synchronized to working clock	Free running	Synchronized to working clock	Free running
	802.1.Qbv	Strict Priority	802.1Qbv	Strict Priority

402  
403 **2.4.3 Use case 02: Control Loops with guaranteed low latency**

404 Control loops with guaranteed low latency implement an isochronous traffic pattern for isochronous  
405 applications, which are synchronized to the network access (see Table 3). It is based on a network  
406 cycle, which consists of an IO data Transfer time and a Control calculation time wherein the control  
407 loop function is executed.

408 Figure 8 shows the principle how network cycle, transfer time and application time interact in this  
409 use case. The control loop function starts for controllers and devices after the transfer time when all  
410 necessary buffers are available. A single execution of a control loop function ends before the next  
411 transfer time period starts. Thus, all frames must be received by the addressed application within  
412 the transfer time. An optimized local transmit order at sender stations is required to achieve  
413 minimal transfer time periods.

414

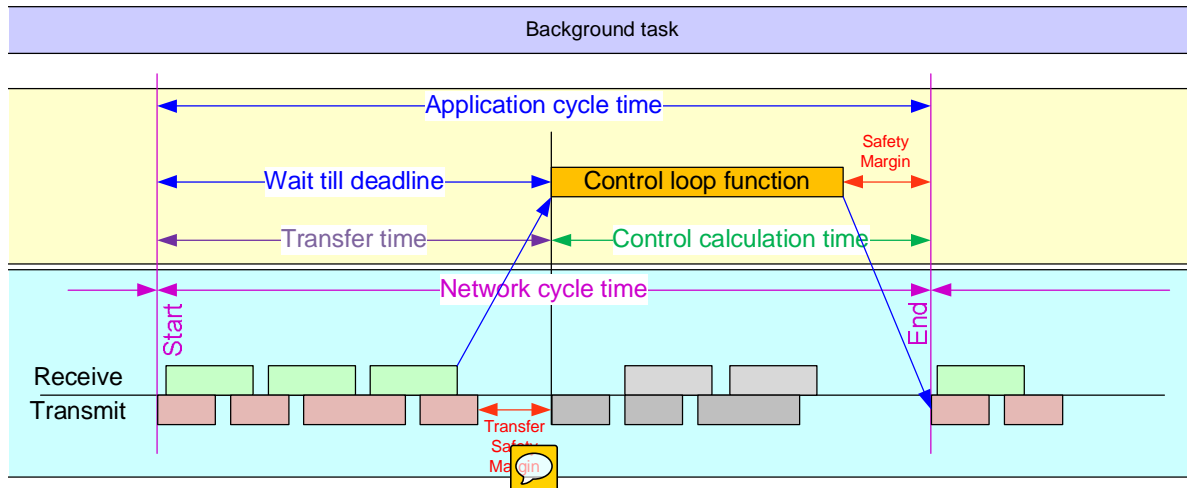

415

416

**Figure 8 – network cycle and isochronous application (Basic model)**

417

Figure 9 shows how this principle is used for multiple concurrent applications with even extended computing time requirements longer than a single application time within the network cycle time.

418

419

When reduction ratio >1 is applied (see 2.4.5), the control loop function can be expanded over multiple network cycles (Control loop 2 with reduction ratio 2 and Control loop 3 with reduction ratio 16 in Figure 9).

421

422

Maximum available computation time for a Control loop with reduction ratio X:

423

$$X * \text{network cycle time} - \text{Transfer time} - \text{Application safety margin}$$

424

Transfer of isochronous cyclic real-time, cyclic real-time and non-real-time data is processed in parallel to the various control loop functions - preserving the deadline requirement of the control loops.

426

427

A background task can additionally run, when free compute time is available.



428

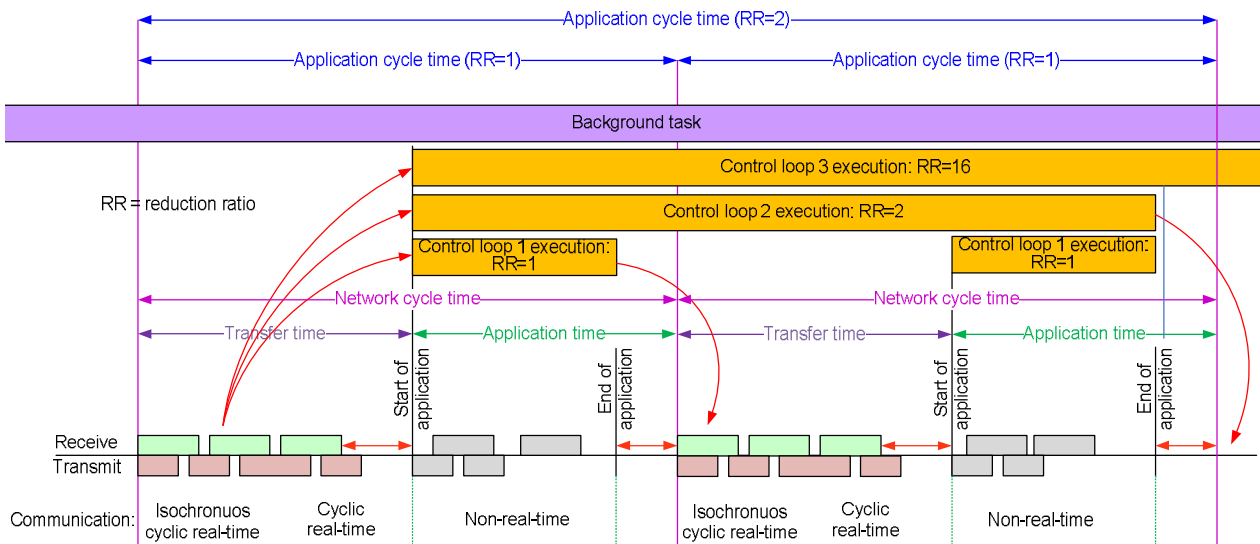

429

**Figure 9 – Multiple concurrent isochronous control loops (Extended model)**

430

431

Network cycle: transfer time (including safety margin) and application time (including safety margin)

432 Transfer time: period of time, wherein all necessary frames are exchanged between stations  
 433 (controller, devices); the minimum transfer time is determined by the e2e latencies of the necessary  
 434 frames; the e2e latency depends on: PHY-delays, MAC-delays, bridge-delays and send ordering.  
 435 The transfer time is a fraction of the network cycle time.

436 For a given target transfer time the number of possible bridges on the path is restricted due to  
 437 PHY-, MAC- and bridge-delay contributions.

438 Figure 10 to Figure 15 show variations of the basic model of Figure 8:

439 In existing technologies some of the models are used in optimized ways to reduce the network  
 440 cycle time and/or the IO-reaction time (sometimes also called 'makespan' or 'roundtrip delay time').  
 441

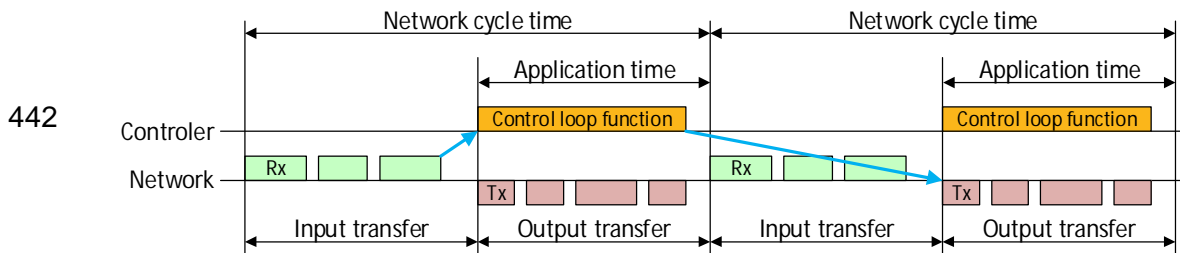

442 **Figure 10 – Variation 1: two cycle timing model**

444

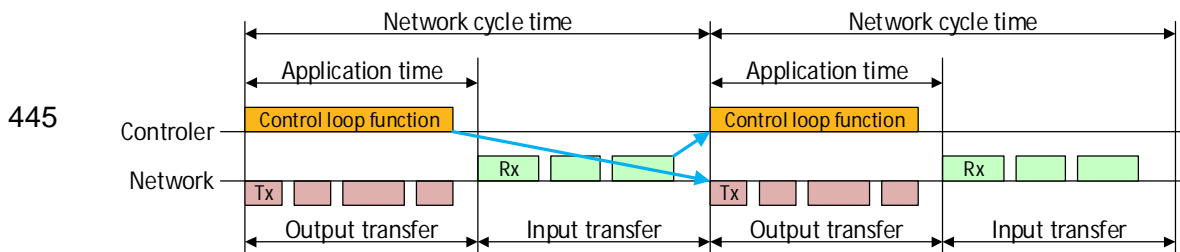

445 **Figure 11 – Variation 2: two cycle timing model - shifted by 180°**

447

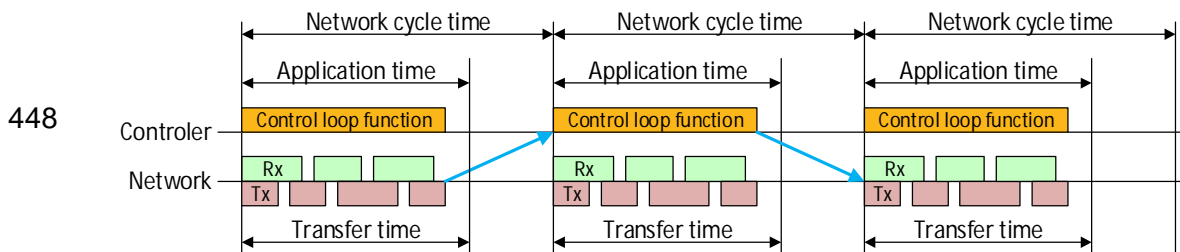

448 **Figure 12 – Variation 3: three cycle timing model**

450

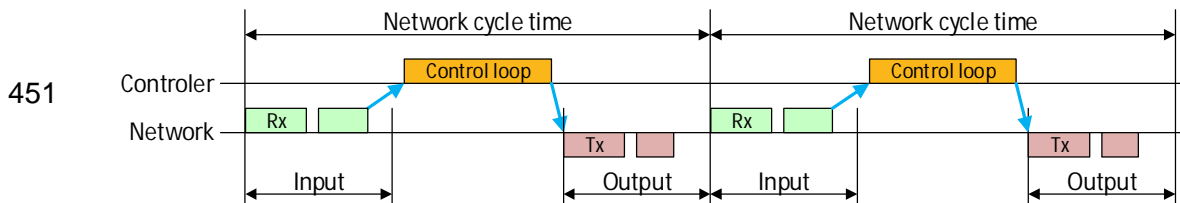

451 **Figure 13 – Variation 4: one cycle timing model**

452

453

454

455

456

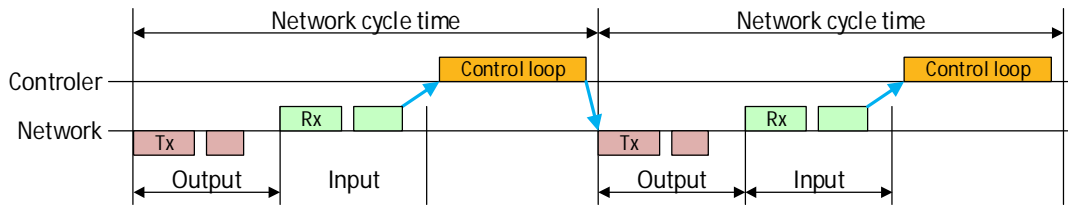

**Figure 14 – Variation 5: one cycle timing model – changed sequence**

457

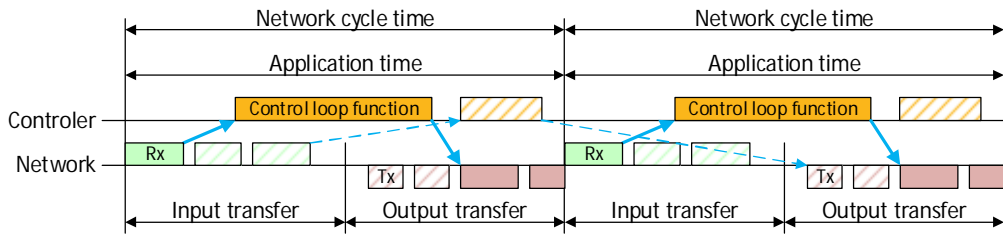

**Figure 15 – Variation 6: further optimizations**

458

459

460

The extended model of Figure 9 may be applied to these variations as well.

461

*2.4.3.1 Isochronous cyclic operation model*

462

Figure 16 shows the isochronous cyclic operation model for guaranteed low latency.

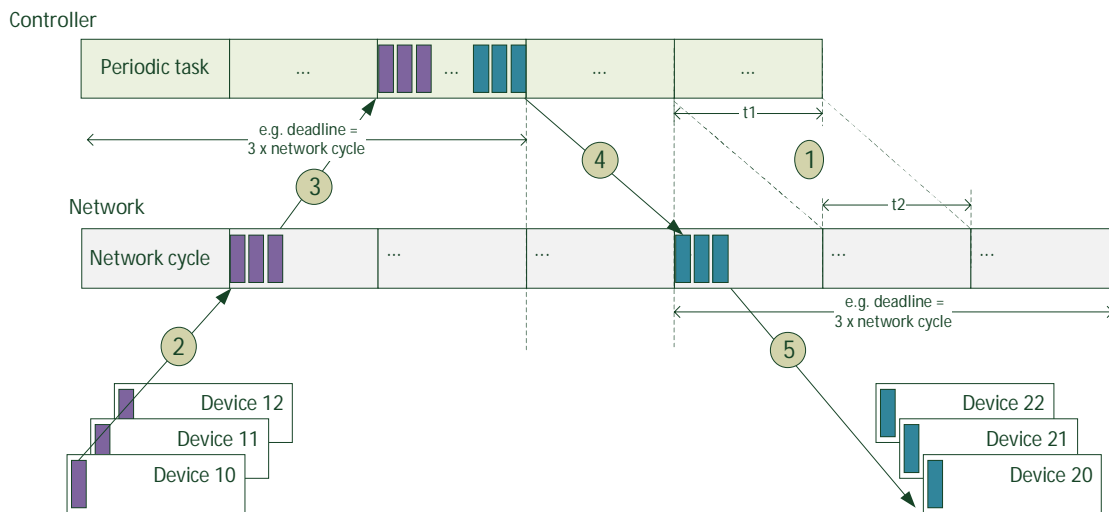

463

464

**Figure 16 – isochronous cyclic operation model**

Isochronous cyclic operation characteristics:

Multiple applications (periodic tasks) with different application periods are supported.  
 Applications are synchronized to working clock:

- Devices:  $\ddot{O}$
- Controller:  $\ddot{O}$

Multiple application update times based on different reduction ratios are supported.  
Data transmission is synchronized to network cycle (WorkingClock):

- Devices:     Ö
- Controller:  Ö

The single steps of the isochronous cyclic operation model are:

1	<p>Controller periodic tasks are synchronized to the working clock. Example: Periodic task_01 period (t1) == network cycle period (t2). Periodic task_02 period == 8 * network cycle period (t2). Periodic task_03 period == 32 * network cycle period (t2).</p>
2	<p>Device data transmission is synchronized to network cycle (Working Clock).</p>
3	<p>Device input data must reach controller within an application defined deadline. Controller application may check the timeliness (by means of additional data in the payload, e.g. LifeSign model). Controller application operates on local process image data. Local process image decouples communication protocol from application.</p> <p>Additional: Device input data must reach controller within a communication monitoring defined deadline (communication protocol). Communication disturbances are recognized and signaled asynchronously by communication protocol to application.</p>
4	<p>Controller output data transmission is synchronized to network cycle (Working Clock).</p>
5	<p>Controller output data must reach device within an application defined deadline. Device application may check the timeliness (by means of additional data in the payload, e.g. PROFINET Isochronous Mode SignOfLife model – see [3]). Device application operates on local process image data. Local process image decouples communication protocol from application.</p> <p>Additional: Controller out data must reach device within a communication monitoring defined deadline (communication protocol). Communication disturbances are recognized and signaled asynchronously by communication protocol to application.</p>

465

466

High control loop quality is achieved by:

467

468

469

470

471

472

- Short network cycle times to minimize reaction time (dead time),
- equidistant network cycle times based on a synchronized working clock to ensure a defined reaction time,
- device signal processing and transfer coupled to synchronized working clock, and
- device and controller application (function) coupled to synchronized working clock.

473

474

isochronous mode: coupling of device and controller application (function) to the synchronized working clock

475

476

isochronous cyclic real-time: transfer time less than 20%/50% of network cycle and applications are coupled to the working clock.

477

**Table 4 – isochronous traffic pattern properties**

Characteristics		Notes
Data transmission scheme	periodic	
Data transmission constraints	deadline	End-to-end one-way latency <sup>2</sup> less than 20% (link speeds > 100 Mbit/s) / 50% (link speeds <= 100 Mbit/s) of network cycle
Data period	1µs .. 1ms 250µs .. 4ms	
Data transmission synchronized to network cycle	Yes	
Application synchronized to working clock	Yes	
Acceptable jitter	n.a.	Deadline shall be kept
Acceptable frame loss	0..n frames	Media redundancy requirements according to the required tolerance; e.g. seamless redundancy for value 0
Payload	1 .. IEEE Std 802.3 maximum data payload size (i.e. 1500 bytes)	Data size negotiated during connection establishment

478

479

isochronous domain: All stations, which share a common

480

- working clock,

481

- network cycle, and

482

- traffic model (traffic class definition).

483

Requirements on network cycle times:

484

- 1 µs to 1 ms at link speed 1 Gbit/s (or higher)

485

- 250 µs to 4 ms at link speed 100 Mbit/s (or lower, e.g. 10 Mbit/s)

486

### 2.4.3.2 Delay requirements

487

To make short control loop times feasible PHY, MAC and bridge delays shall meet upper limits:

488

- PHY delays shall meet the upper limits of Table 5.

489

- MAC delays shall meet the upper limits of Table 6.

490

- Bridge delays shall be independent from the frame size and meet the upper limits of Table 7.

491

Figure 17 shows the definition of PHY delay, MAC delay and Bridge delay reference points.

<sup>2</sup> The end-to-end one-way latency is measured from the arrival of the last bit at the ingress edge port of the bridged network to the transmission of the last bit by the egress edge port of the bridged network (see, e.g., Annex L.3 in IEEE Std 802.1Q-2014).

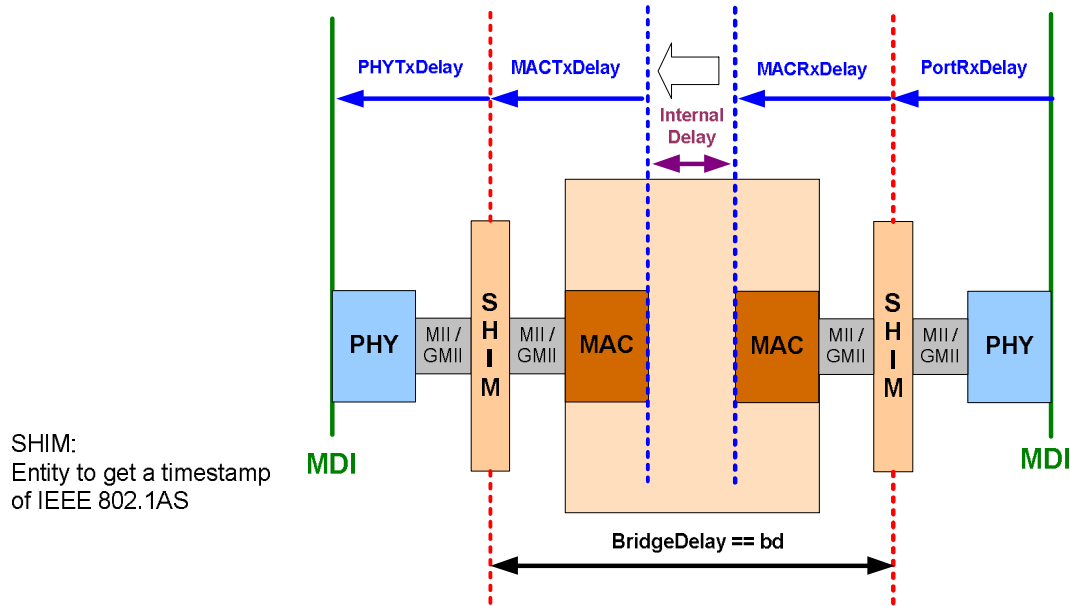

Figure 17 – delay measurement reference points

492  
493  
494

495



Table 5 – Expected PHY delays

Device	RX delay <sup>c</sup>	TX delay <sup>c</sup>	Jitter
10 Mbit/s	<< 1 μs	<< 1 μs	< 4 ns
100 Mbit/s MII PHY	210 ns (Max. 340 ns) <sup>a</sup>	90 ns (Max. 140 ns) <sup>a</sup>	< 4 ns
100 Mbit/s RGMII PHY	210 ns <sup>b</sup>	90 ns <sup>b</sup>	< 4 ns
1 Gbit/s RGMII PHY	<< 500 ns <sup>b</sup>	<< 500 ns <sup>b</sup>	< 4 ns
2,5 Gbit/s RGMII PHY	<< 500 ns <sup>b</sup>	<< 500 ns <sup>b</sup>	< 4 ns
5 Gbit/s RGMII PHY	<< 500 ns <sup>b</sup>	<< 500 ns <sup>b</sup>	< 4 ns
10 Gbit/s	Tdb	tbd	tbd
25 Gbit/s – 1 Tbit/s	n.a.	n.a.	n.a.

<sup>a</sup> According IEEE 802.3 for 100 Mbit/s full duplex with exposed MII.  
<sup>b</sup> Values from 100 Mbit/s PHYs (or better) are needed to allow substitution even for Gigabit or higher.  
<sup>c</sup> Lower values mean more performance for linear topology.

496

497

Table 6 – Expected MAC delays

Link speed	Maximum RX delay	Maximum TX delay
10 Mbit/s	<< 1 μs	<< 1 μs
100 Mbit/s	<< 1 μs	<< 1 μs
1 Gbit/s	<< 1 μs	<< 1 μs



Link speed	Maximum RX delay	Maximum TX delay
2,5 Gbit/s	<< 1 $\mu$ s	<< 1 $\mu$ s
5 Gbit/s	<< 1 $\mu$ s	<< 1 $\mu$ s
10 Gbit/s	<< 1 $\mu$ s	<< 1 $\mu$ s
25 Gbit/s – 1 Tbit/s	n.a.	n.a.

498  
499

**Table 7 – Expected Ethernet Bridge delays**

Link speed	Value	Comment
10 Mbit/s	< 30 $\mu$ s	No usage of bridging expected
100 Mbit/s	< 3 $\mu$ s	Bridge delay measure from MII to MII
1 Gbit/s	< 1 $\mu$ s	Bridge delay measure from RGMII to RGMII
2,5 Gbit/s	< 1 $\mu$ s	Bridge delay measure from XGMII to XGMII
5 Gbit/s	< 1 $\mu$ s	Bridge delay measure from XGMII to XGMII
10 Gbit/s	< 1 $\mu$ s	Bridge delay measure from XGMII to XGMII
25 Gbit/s – 1 Tbit/s:	n.a.	No covered by this specification

500 Useful 802.1 mechanisms:

501 . . .  
502

503 Example:

504 A representative example of a “Control loop with guaranteed low latency” use case is given in  
505 clause 2.5.11.4 “Fast” process applications.  
506

507 **2.4.4 Use case 03: Control Loops with bounded latency**

508 Control loops with bounded latency implement a cyclic traffic pattern for non-isochronous  
509 applications, which are not synchronized to the network access (see Table 3).

510 Figure 18 shows the principle how network cycle, transfer time and application time interact in this  
511 use case. The control loop function starts at an application defined time, which is not synchronized  
512 to the network access.

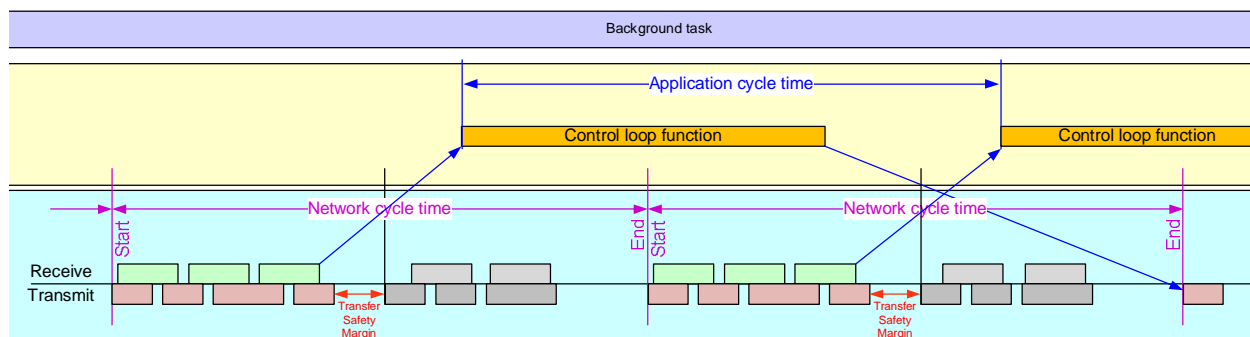

513  
514 **Figure 18 – network cycle and non-isochronous application (Basic model)**

515 Extensions of this model analogous to Figure 9 (multiple applications with differing application  
516 lengths) are also possible.

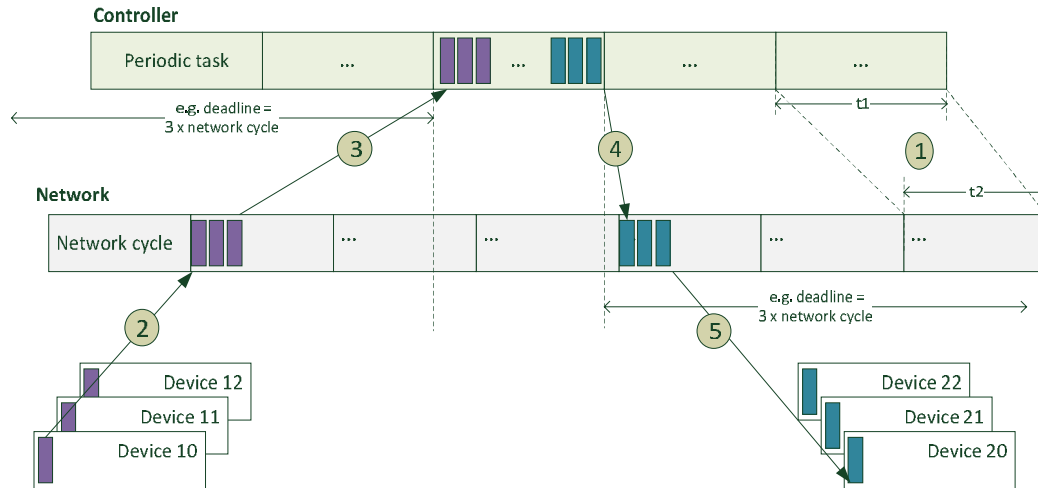

518  
519  
520  
521

Figure 19 – cyclic operation model

Cyclic operation characteristics:

Multiple applications with different application periods are supported.  
Applications don't need to be synchronized to working clock, but may be synchronized

- Devices:  $\ddot{O}$
- Controller:  $\ddot{O}$

Multiple update times based on different reduction ratios are supported.  
Network access is synchronized to network cycle (WorkingClock):

- Devices:  $\ddot{O}$
- Controller:  $\ddot{O}$

522 The single steps of the cyclic operation model are:

1	Controller periodic tasks don't need to be synchronized to working clock, but may be synchronized. Periodic task period ( $t_1$ ) $\neq$ network cycle period ( $t_2$ ).
2	Data transmission is synchronized to network cycle (Working Clock)
3	Device input data must reach controller within a communication monitoring defined deadline (communication protocol). Controller application assumes a kept update interval but doesn't know whether it is kept or not. Communication disturbances are recognized and signaled asynchronously by communication protocol to application. Controller application operates on local process image data. Local process image decouples communication protocol from application.
4	Controller output data transmission is synchronized to network cycle (Working Clock).

5	<p>Controller output data must reach device within a communication monitoring defined deadline (communication protocol).</p> <p>Device application assumes an kept update interval but doesn't know whether it is kept or not.</p> <p>Communication disturbances are recognized and signaled asynchronously by communication protocol to application.</p> <p>Device application operates on local process image data. Local process image decouples communication protocol from application.</p>
---	--

523

524 *2.4.4.2 Cyclic traffic pattern*

525 Control loops with bounded latency implement a cyclic traffic pattern. More relaxed control reaction  
 526 time requirements (e.g. 10 ms - 10 s) allow free running applications instead of isochronous  
 527 applications. In consequence transfer time requirements are more relaxed as well. The transfer  
 528 time may be longer than the network cycle in this use case.

529 For a given target transfer time the number of possible bridges on a communication path is  
 530 restricted due to PHY-, MAC- and bridge-delay contributions, but can be much higher compared to  
 531 Use case 02: Control Loops with guaranteed low latency.

532 Cyclic real-time: transfer time may be longer than network cycle and applications are decoupled  
 533 from the working clock.

534 **Table 8 – cyclic traffic pattern properties**

Characteristics		Notes
Data transmission scheme	periodic	
Data transmission constraints	deadline	End-to-end one-way latency <sup>3</sup> less than X * network cycle (X   1 .. n)
Data period	X * network cycle (X   1 .. n)	
Data transmission synchronized to network cycle	Yes	
Application synchronized to working clock	No	
Acceptable jitter	n.a.	Deadline shall be kept
Acceptable frame loss	0..n frames	Media redundancy requirements according to the required tolerance; e.g. seamless redundancy for value 0
Payload	1 .. IEEE Std 802.3 maximum data payload size (i.e. 1500 bytes)	Data size negotiated during connection establishment

535

536 Cyclic real-time domain: All stations, which share a common

537 . traffic model (traffic class definition).

538

<sup>3</sup> The end-to-end one-way latency is measured from the arrival of the last bit at the ingress edge port of the bridged network to the transmission of the last bit by the egress edge port of the bridged network (see, e.g., Annex L.3 in IEEE Std 802.1Q-2014).

539

Requirements:

540

Stations shall be able to implement Use case 03: Control Loops with bounded latency and Use case 03: Control Loops with bounded latency concurrently.

541

542

Transmission paths shall be able to handle different

543

- working clocks, and

544

- network cycles.

545

Useful 802.1 mechanisms:

546

- ...

547

548

## 2.4.5 Use case 04: Reduction ratio of network cycle

549

550

Application needs may limit the in principle flexible network cycle time to a defined granularity.

551

E.g. in case of network cycle granularity 31,25  $\mu$ s the possible network cycles are:

552

$$\geq 1\text{Gbit/s: } 31,25 \mu\text{s} * 2^n \mid n=0 \dots 5$$

553

$$< 1\text{Gbit/s: } 31,25 \mu\text{s} * 2^n \mid n=2 \dots 7$$

554

555

Application cycle times are the result of the used network cycle times together with reduction ratios:

556

- 31,25  $\mu$ s to 512 ms

557

558

Reduction ratio: The value of “reduction ratio” defines the number of network cycles between two consecutive transmits.

559

560

Phase: The value of “phase” in conjunction with “reduction ratio” defines the starting network cycle for the consecutive transmits.

561

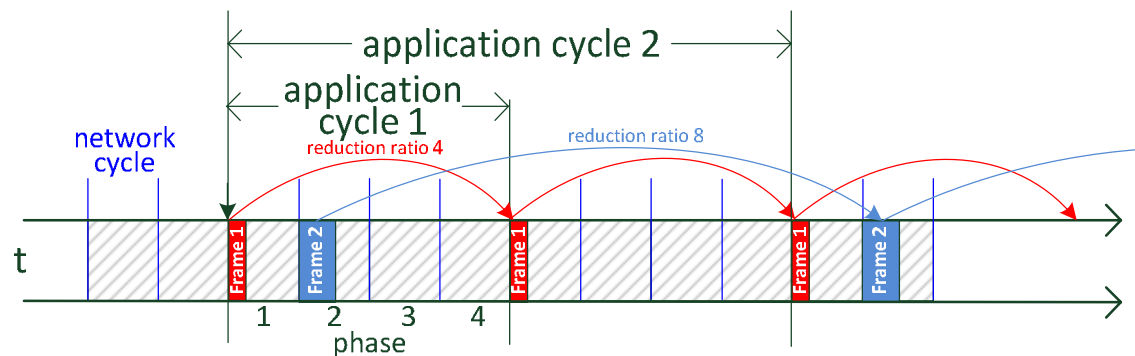

562

563

**Figure 20 – network cycle and application cycle**

564

Examples: see Use case 06: Drives without common application cycle but common network cycle.

565

Requirements:

566

- ...

567

Useful 802.1 mechanisms:

568

- ...

## 569 2.4.6 Use case 05: Drives without common application cycle

## 570 2.4.6.1 Background information

571 The cycle time requirements of different vendors may be based on their technology, which cannot  
 572 be changed with reasonable effort. These requirements may be based on hardware dependencies,  
 573 independent of the capabilities of the communication part of the device.

574 Figure 21 shows an example, where Vendor A needs to communicate with 31,25  $\mu$ s between its  
 575 devices (A1 with A2), and Vendor B needs to communicate with 50  $\mu$ s (between B1 and B2).  
 576 The communication with the controller which has to coordinate both of them must be a multiple of  
 577 their local cycles. A1 needs to exchange data every 125 $\mu$ s with the Controller, B1 needs to  
 578 exchange data every 200 $\mu$ s with the Controller.

579 Servo drives from different vendors (Vendor A and Vendor B) are working on the same network.  
 580 For specific reasons the vendors are limited in the choice of the period for their control loop.

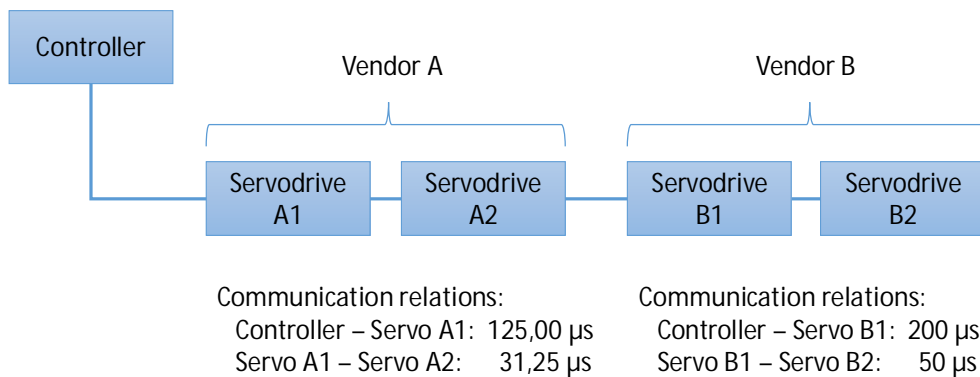

581

582

583

**Figure 21 – network with different application cycles**

584 The following Communication Relations are expected to be possible:

585 Servodrive A1  $\rightarrow$  Servodrive A2: 31,25  $\mu$ s

586 Servodrive B1  $\rightarrow$  Servodrive B2: 50  $\mu$ s

587 Controller  $\rightarrow$  Servodrive A1: 125  $\mu$ s

588 Controller  $\rightarrow$  Servodrive B1: 200  $\mu$ s

589 Servodrive A1  $\rightarrow$  Servodrive B1: 1 ms

590

591 Figure 22 shows a similar use case where all drives are connected in a line and every drive needs  
 592 direct data exchange to the Controller and additionally to its direct neighbor.

593 Some applications might be more complex where the physical topology does not match the logical  
 594 order of drives.

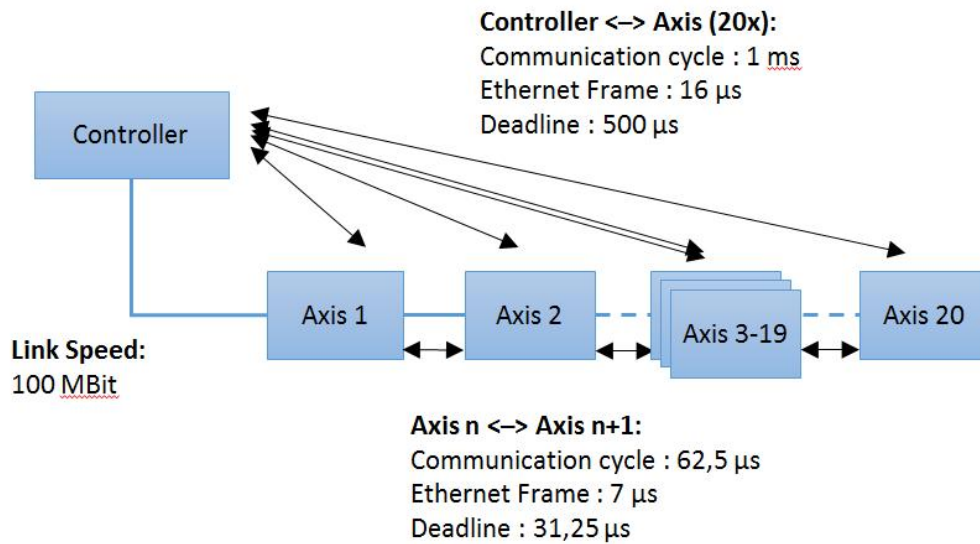

Figure 22 – isochronous drive synchronization

595

596  
597

598 Requirements:

- 599 - Isochronous data exchange
- 600 - Different cycles for data exchange, which are not multiples of each other
- 601 (cycles are not multiple of a common base, but fractions of a common base, here for
- 602 instance 1 ms)

603  
604

Useful 802.1Q mechanisms:

- 605 · Whatever helps
- 606 · ...

607

608 [2.4.6.2 Controller communication](#)

609 The Usecase concentrates on the communication between the devices A1 and B1, and the  
 610 Controller as shown in Figure 23. Nevertheless the communication between A1/A2 and B1/B2 has  
 611 to be solved as well.

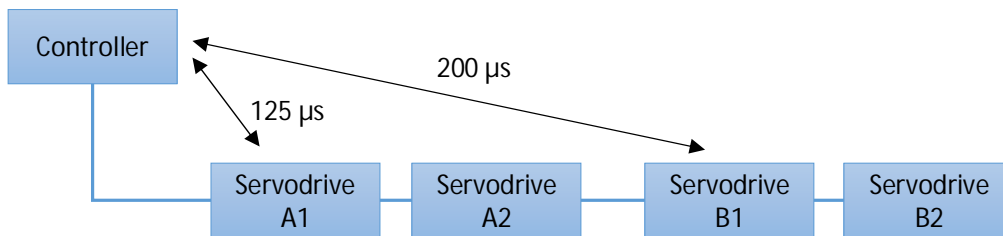

612

613  
614

Figure 23 – Multivendor Motion – Controller communication

## 615 2.4.6.3 Timing Requirements

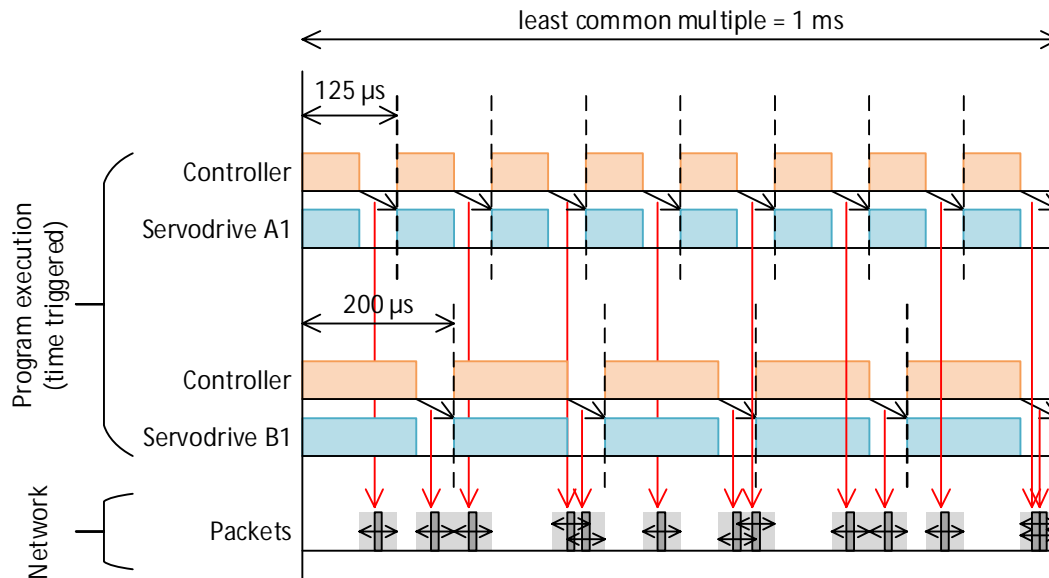

616

617

618

**Figure 24 – Multivendor Motion – Timing Requirements**

619 The Controller runs 2 parallel programs in multitasking, one program with 125  $\mu\text{s}$  cycle, and  
 620 another with 200  $\mu\text{s}$  cycle. Alternatively there might also be 2 independent controllers on the same  
 621 network, one of vendor A and one of vendor B.

622 After every program execution, data needs to be exchanged between Controller and Servodrive.  
 623 The time window for this exchange is application specific.

624 The actual data exchange on the wire can happen at any time in this window, the devices are not  
 625 dependent on any exact transmission or reception timing, as long as the packet is in the scheduled  
 626 window.

#### 627 2.4.7 Use case 06: Drives without common application cycle but common network cycle

628 The concept of multiple different application cycles which are based on a common network cycle is  
 629 described in Use case 04: Reduction ratio of network cycle.

630 Examples with different application cycle times but common network cycle time 31,25  $\mu\text{s}$ :

- 631 - 31,25  $\mu\text{s}$ , i.e. reduction ratio 1 for current control loop,
- 632 - 250  $\mu\text{s}$ , i.e. reduction ratio 4 for position control loop,
- 633 - 1 ms, i.e. reduction ratio 16 for motor speed control loop,
- 634 - 16 ms, i.e. reduction ratio 256 for remote IO.







## 639 2.5 Industrial automation networks

## 640 2.5.1 Use case 07: Redundant networks

641 Ring topologies are the basic industrial network architecture for switch-over or seamless  
642 redundancy.

643

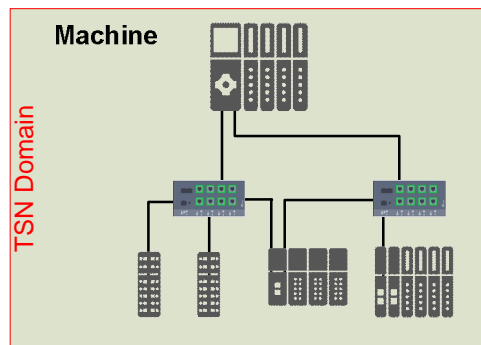

644

Figure 26 – ring topology

645 When a production cell is also arranged in a ring topology the resulting architecture of cell with  
646 attached machines is a connection of rings.

647 To even improve availability of the connection from the production cell into the machines this link  
648 can be arranged redundantly as well (machine 1 in Figure 27):

649

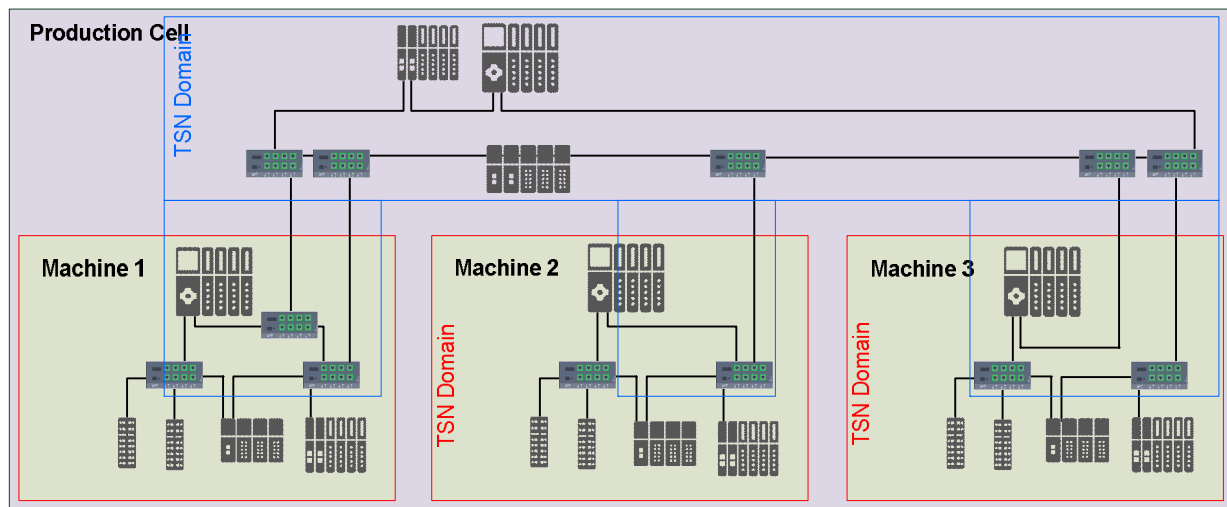

650

Figure 27 – connection of rings

651 Requirement:

652 Support redundant topologies with rings.

653

654 Useful 802.1 mechanisms:

655 . ...

656

## 657 2.5.2 Use case 08: High Availability

658 High availability systems are composed of:

- 659 . Redundant networks, and
- 660 . Redundant stations.

661 E.g. tunnel control:

662 Tunnels need to be controlled by systems supporting high availability because airflow and fire  
 663 protection are crucial for the protection of people's lives. In this case PLC, remote IO and network  
 664 are installed to support availability in case of failure.

665

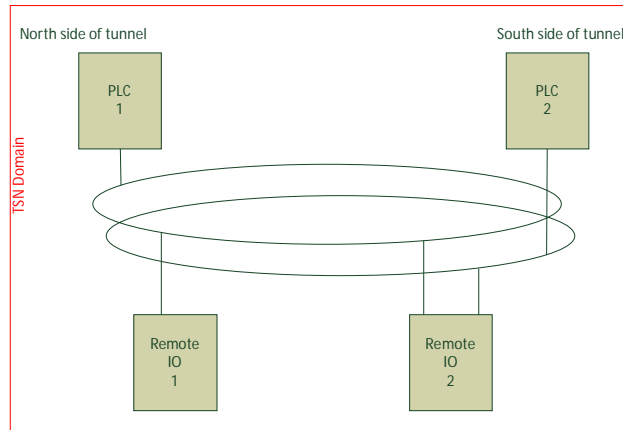

666 **Figure 28 – example topology for tunnel control**

667 Requirement:

668 Failure shall not create process disturbance – e.g. keep air flow active / fire control active.  
 669 The number of concurrent active failures without process disturbance depends on the application  
 670 requirements and shall not be restricted by TSN profile definitions.  
 671 Parameter, program, topology changes need to be supported without disturbance.

672 Useful 802.1Q mechanisms:

- 674 . Redundancy for PLCs, Remote IOs and paths through the network
- 675 . ...

676

677 Further high availability control applications:

- 678 . Ship control
- 679 . Power generation
- 680 . Power distribution
- 681 . ...

682

### 683 2.5.3 Use case 09: Wireless

684 HMI panels, remote IOs, wireless sensors or wireless bridges are often used in industrial  
 685 machines. Wireless connections may be based on IEEE 802.11 (Wi-Fi), IEEE 802.15.1 (Bluetooth),  
 686 IEEE 802.15.4 or 5G.

687

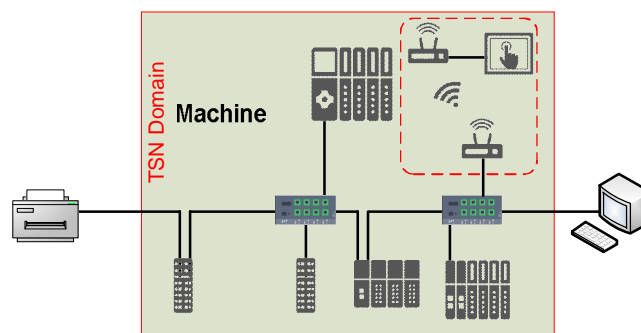

688

**Figure 29 – HMI wireless connected using cyclic real-time**

689

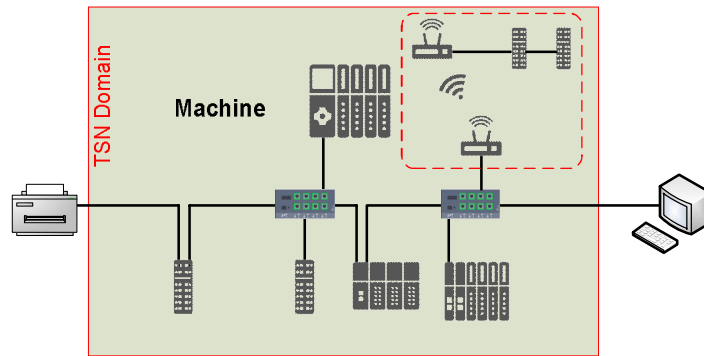

690

**Figure 30 – Remote IO wireless connected using cyclic real-time**

691

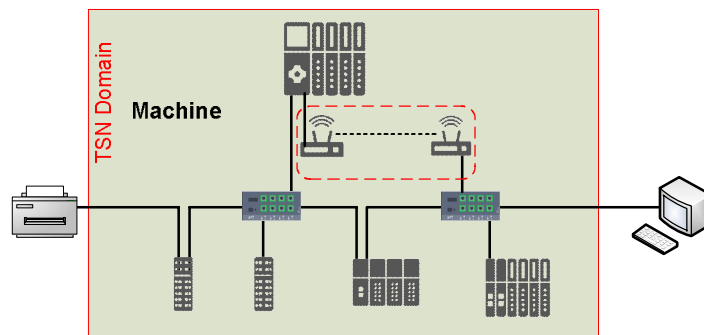

692

**Figure 31 – Ring segment wireless connected for media redundancy**

693

694

**Requirement:**

695

## Support of wireless for

696

- cyclic real-time, and

697

- non-real-time communication

698

699

**Useful 802.11 mechanisms:**

700

- Synchronization support

701

- Extensions from .11ax

702

- ...

703

704

**Useful 802.15.1 mechanisms:**

705

- ...

706

707

**Useful 802.1Q mechanisms:**

708

- ...

709

710

**2.5.4 Use case 10: 10 Mbit/s end-stations (Ethernet sensors)**

711

Simple and cheap sensor end-stations are directly attached via 10 Mbit/s links to the machine

712

internal Ethernet and implement cyclic real-time communication with the PLC.

713 The support of additional physics like “IEEE 802.3cg APL support” is intended.  
 714

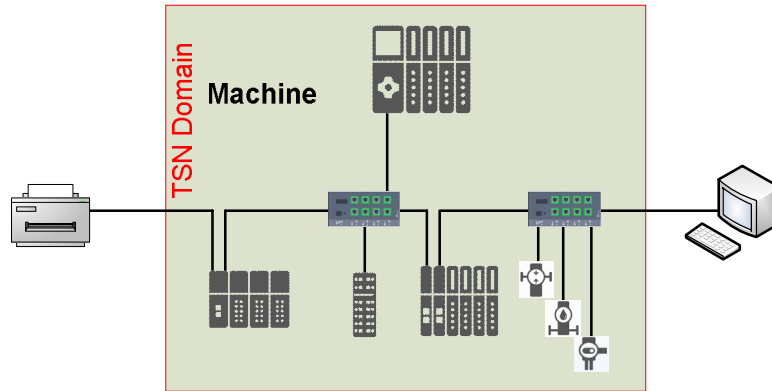

715

716

**Figure 32 – Ethernet sensors**

717

Requirement:

718 Support of 10 Mbit/s or higher link speed attached sensors (end-stations) together with POE and  
 719 SPE (single pair Ethernet).

720

721

Useful 802.1Q mechanisms:

722

• ...

723 [2.5.5 Use case 11: Fieldbus gateway](#)

724 Gateways are used to integrate non-Ethernet fieldbuses into TSN domains.  
 725

725

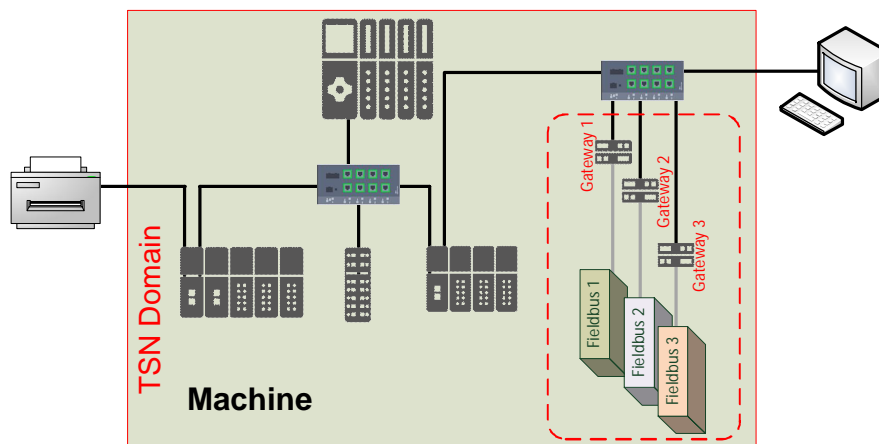

726

727

**Figure 33 – fieldbus gateways**

728

Requirement:

729 Support of non-Ethernet fieldbus devices via gateways either transparent or hidden.

730

731

Useful 802.1Q mechanisms:

732

• ...

733

734  
735  
736  
737  
738

2.5.6 Use case 12: New machine with brownfield devices

Brownfield devices with real-time communication are attached to a PLC, which supports both brownfield and greenfield, within a machine. This allows faster deployment of devices supporting the TSN-IA profile into the field. Figure 34 gives an example of a machine with brownfield devices.

739

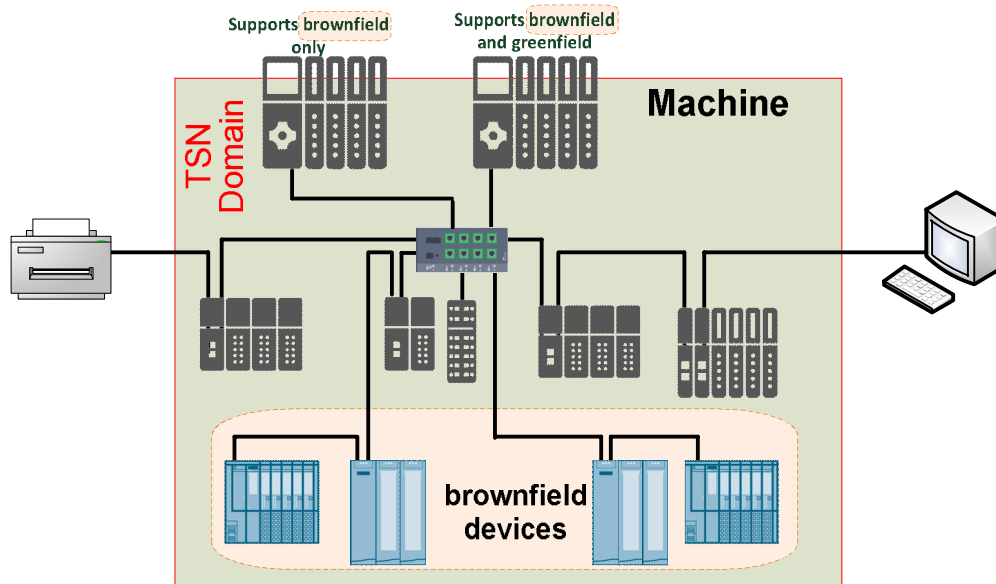

740

Figure 34 – new machine with brownfield devices

741

Requirement:

742  
743  
744  
745  
746

All machine internal stream traffic communication (stream traffic and non-stream traffic) is decoupled from and protected against the brownfield cyclic real-time traffic. Brownfield cyclic real-time traffic QoS is preserved within the TSN domain.

747

Useful 802.1Q mechanisms:

748  
749  
750

- Priority Regeneration,
- separate "brownfield traffic queue".
- Queue-based resource allocation.

751

2.5.7 Use case 13: Mixed link speeds

752  
753  
754

Industrial use cases refer to link speeds, as shown in Table 9, in the range from 10 Mbit/s to 10 Gbit/s for Ethernet and additional Wi-Fi, Bluetooth and 5G. Thus, the TSN domains need to handle areas with different link speeds.

755

Table 9 – Link speeds

Link speed	Media	Comments
100 kbit/s – 3 Mbit/s	Radio Bluetooth	These devices are connected thru a Bluetooth access point. They may be battery powered.
1 Mbit/s – 1 Gbit/s	Radio Wi-Fi	These devices are connected thru a Wi-Fi access point. They may be battery powered.
1 Mbit/s – 10 Gbit/s (theoretical/expected)	Radio 5G	These devices are connected thru a 5G access point. They may be battery powered.

Link speed	Media	Comments
10 Mbit/s	Copper or fiber	May be used for end station “only” devices connected as leafs to the domain. Dedicated to low performance and lowest energy devices for e.g. process automation. These devices may use PoE as power supply.
100 MBit/s	Copper or fiber	Historical mainly used for Remote IO and PLCs. Expected to be replaced by 1 GBit/s as common link speed.
1 GBit/s	Copper or fiber	Main used link speed for all kind of devices
2,5 GBit/s	Copper or fiber	High performance devices or backbone usage
5 GBit/s	Copper or fiber	Backbone usage, mainly for network components
10 GBit/s	Fiber	Backbone usage, mainly for network components
25 GBit/s – 1 Tbit/s	tbd	Backbone usage, mainly for network components

756

757 Mixing devices with different link speeds is a non-trivial task. Figure 35 and Figure 36 show the  
758 calculation model for the communication between an IOC and an IOD connected with different link  
759 speeds.

760 The available bandwidth on a communication path is determined by the path segment with the  
761 minimum link speed.

762 The weakest link of the path defines the usable bandwidth. If the topology guideline ensures that the  
763 connection to the end-station always is the weakest link, only these links need to be checked for the  
764 usable bandwidth.

765

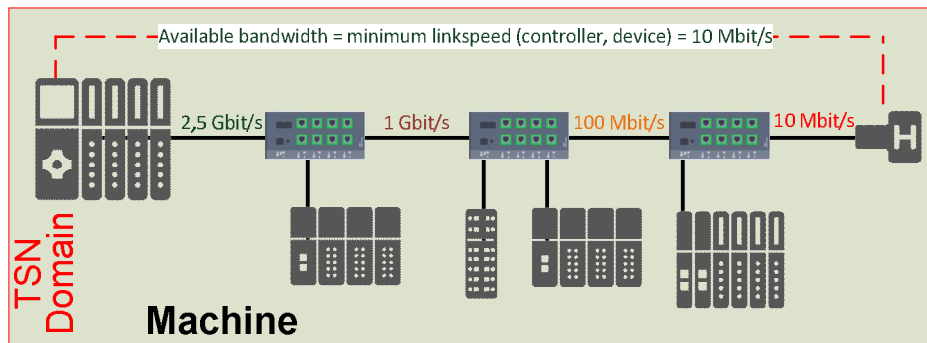

766

Figure 35 – mixed link speeds

767

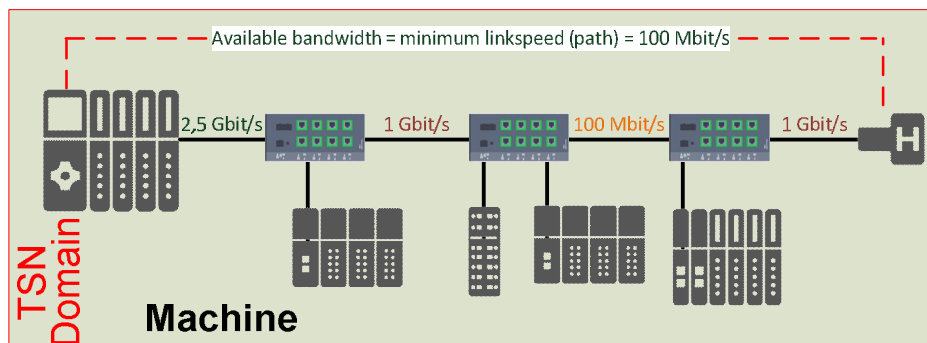

768

Figure 36 – mixed link speeds without topology guideline

769 Requirement:

770 Links with different link speeds as shown in Figure 35 share the same TSN-IA profile based  
771 communication system at the same time.

772 Links with different link speeds without topology guideline (Figure 36) may be supported.

773 Useful 802.1 mechanisms:  
774

775 . . .

### 776 2.5.8 Use case 14: Multiple isochronous domains

777 Figure 37 shows a machine which needs due to timing constraints (network cycle time together  
778 with required topology) two or more separated isochronous real-time domains but shares a  
779 common cyclic real-time domain.

780 Both isochronous domains may have their own Working Clock and network cycle. The PLCs need  
781 to share remote IOs using cyclic real-time traffic.

782

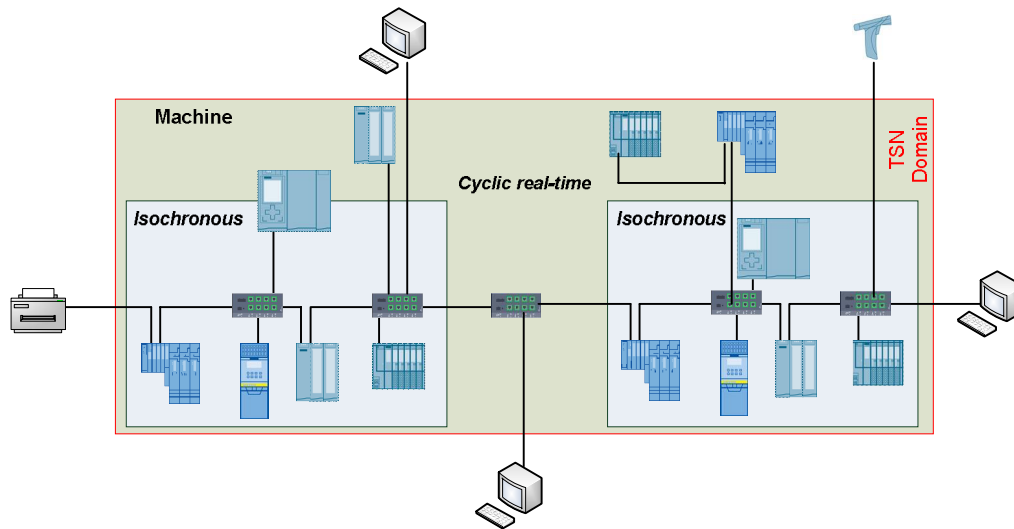

783 **Figure 37 – multiple isochronous domains**

784 Some kind of coupling (e.g. shared synchronization) between the isochronous domains / Working  
785 Clocks may be used (see Figure 38).

786 All isochronous domains may have different network cycle times, but the cyclic real-time data  
787 exchange shall still be possible for PLCs from both isochronous domains.

788

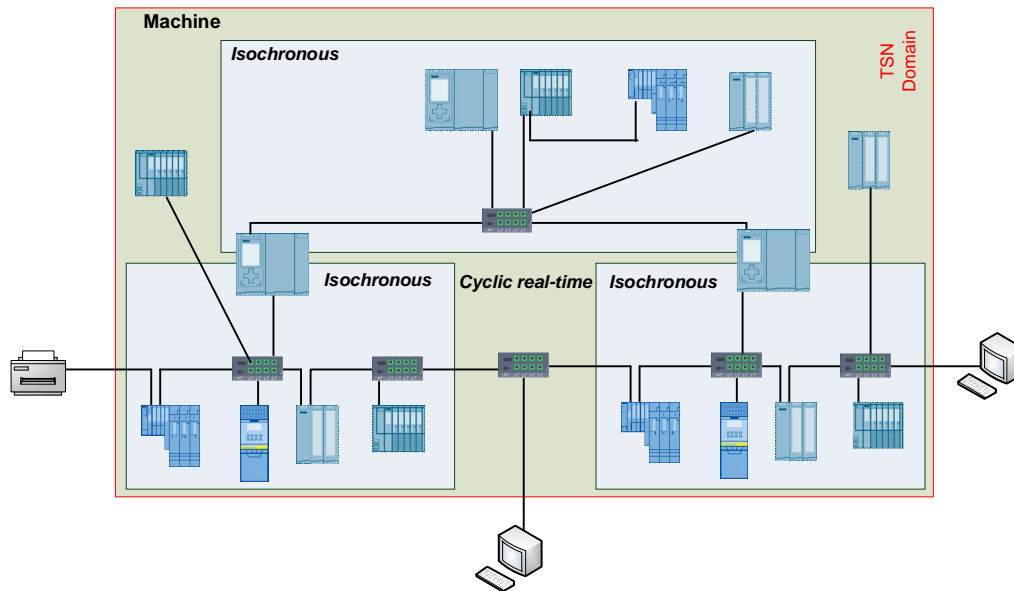

**Figure 38 – multiple isochronous domains - coupled**

789

790

791

Requirements:

792

All isochronous real-time domains may run independently, loosely coupled or tightly coupled. They shall be able to share a cyclic real-time domain.

793

794

795

Useful 802.1 mechanisms:

796

- separate “isochronous” and “cyclic” traffic queues,

797

- Queue-based resource allocation in all bridges,

798

- ...

799

[2.5.9 Use case 15: Auto domain protection](#)

800

Machines are built in a way that not always all devices are really attached either due to different machine models/variants or repair. In this use case a TSN domain shall not expand automatically when e.g. two machines get connected via an unplanned and unintended link.

801

802

803

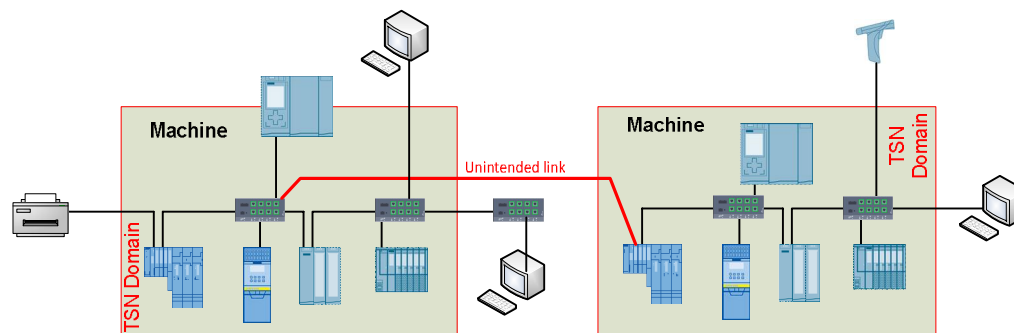

804

805

**Figure 39 – auto domain protection**

806

Requirement:

807

Support of auto domain protection to prevent unintended use of traffic classes



808  
809

Useful 802.1Q mechanisms:

- 810     · Priority regeneration  
811     · ...

812     2.5.10 Use case 16: Vast number of connected stations

813     Some industrial applications need a massive amount of connected stations like

- 814     - Car production sites  
815     - Postal, Parcel and Airport Logistics  
816     - ...

817     Examples for “Airport Logistics”:

- 818     · Incheon International Airport, South Korea  
819     · Guangzhou Baiyun International Airport, China  
820     · London Heathrow Airport, United Kingdom  
821     · Dubai International Airport, UAE  
822     · ...

823

824     Dubai International Airport, UAE

825     Technical Data:

- 826     · 100 km conveyor length  
827     · 222 check-in counters  
828     · car park check-in facilities  
829     · Max. tray speed: 7.5 m/s  
830     · 49 make-up carousels  
831     · 14 baggage claim carousels  
832     · 24 transfer laterals  
833     · Storage for 9,800 Early Bags  
834     · Employing 48 inline screening  
835     · Max. 8-stories rack system  
836     · 10,500 ton steel  
837     · 234 PLC's  
838     · 16,500 geared drives  
839     · [xxxx digital IOs]

840

841

Requirement:

842     Make sure that even this massive amount of stations works together with the TSN-IA profile. This  
843     kind of applications may or may not require wireless support, too.

844

845

Useful 802.1 mechanisms:

- 846     · ...

## 847 2.5.11 Minimum required quantities

## 848 2.5.11.1 A representative example for VLAN requirements

849 Figure 40 shows the IEEE 802.1Q based stacked physical, logical and active topology model. This  
850 principle is used to build TSN domains.

851 It shows the different active topologies driven by either VID (identified by VLAN) or protocol  
852 (identified by DA-MAC and/or protocol type).

853 Additionally the number of to be supported VIDs per bridge is shown. The number of protocol agent  
854 defined active topologies is just an example because e.g. LLDP, RSTP or MST is missing.

855 The following topologies, trees and VLANs are shown in Figure 40.

<	Physical network topology	all existing devices and links
⊞	Logical network topology	<b>TSN domain:</b> administrative selection of elements from the physical topology
•	Active default topology	Default VLAN: result of a spanning tree algorithm (e.g. RSTP)
⌘	Cyclic RT	VLAN for cyclic rea-time streams
•	Cyclic RT „R”	VLAN for redundant cyclic rea-time streams
•	Isochronous cyclic RT 1	VLAN for isochronous cyclic rea-time streams
'	Isochronous cyclic RT 1 „R”	VLAN for redundant isochronous cyclic rea-time streams
'	Isochronous cyclic RT 2	VLAN for isochronous cyclic rea-time streams
“	Working clock	gPTP sync tree used for the synchronization of a working clock
”	Working clock „R”	Hot standby gPTP sync tree used for the synchronization of a working clock
⊞<	Universal time	gPTP sync tree used for the synchronization of universal time

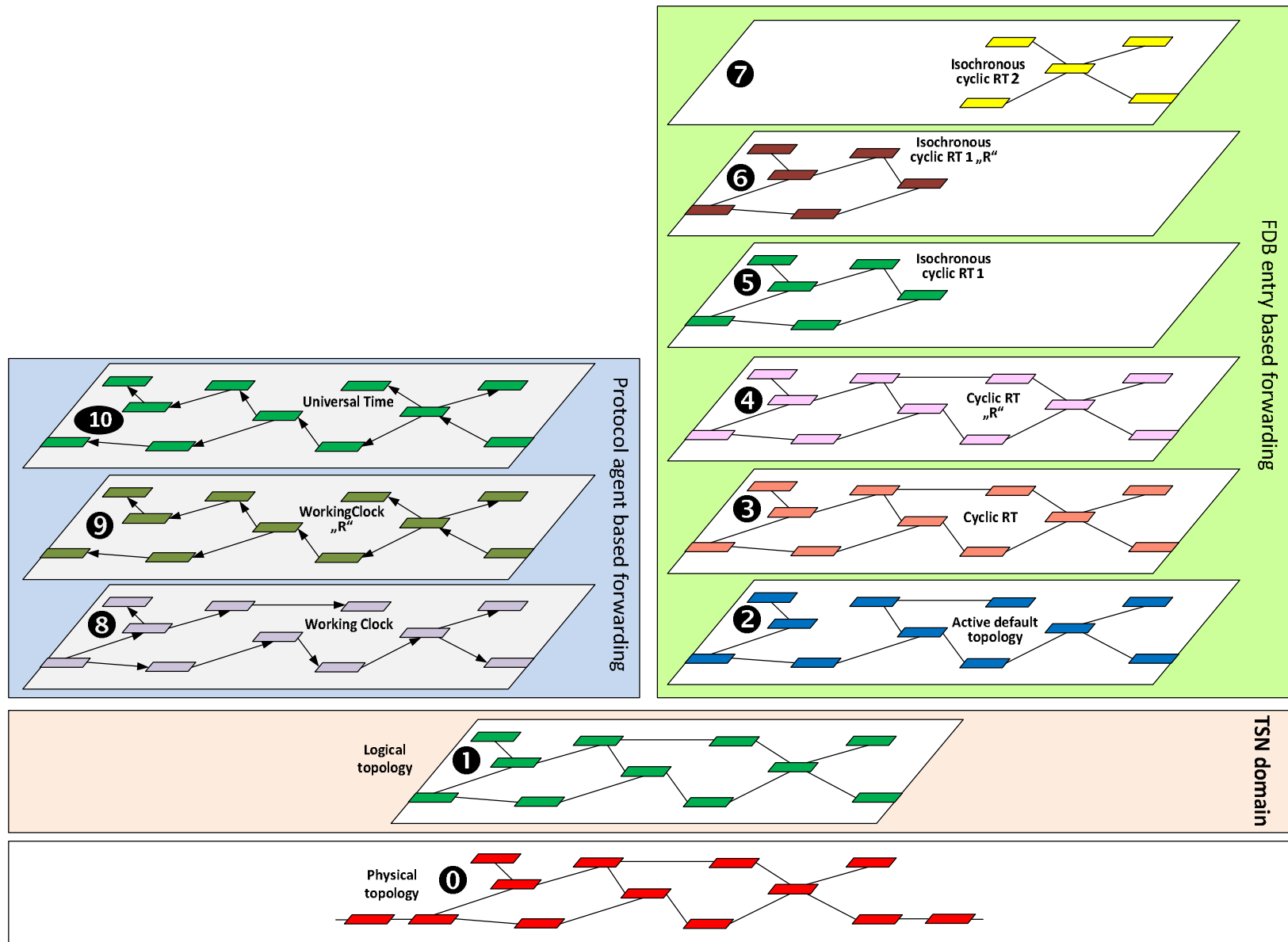

Figure 40 – Topologies, trees and VLANs

856  
857

858

859 Expected numbers of DA-MAC address entries used together with five VLANs (Default, High, High  
860 Redundant, Low and Low Redundant) are shown in Table 10 and Table 11.

861

**Table 10 – Expected number of stream FDB entries**

# of VLANs	# of DA-MACs	Usage
4	4 096	Numbers of DA-MAC address entries used together with four VLANs (High, High Red, Low and Low Red)

862

863 Expected number of entries is given by the maximum device count of 1 024 together with the 50%  
864 saturation due to hash usage rule.

865 Table 11 shows the expected number of possible FDB entries.

866

**Table 11 – Expected number of non-stream FDB entries**

# of VLANs	# of entries	Usage
1	2 048	Learned and static entries for both, Unicast and Multicast

867

868 The hash based FDBs shall support a neighborhood for entries according to Table 12.

869

**Table 12 – Neighborhood for hashed entries**

Neighborhood	Usage
4	Optional A neighborhood of four entries is used to store a learned entry if the hashed entry is already used. A neighborhood of four entries for the hashed index is check to find or update an already learned forwarding rule.
8	Default A neighborhood of eight entries is used to store a learned entry if the hashed entry is already used. A neighborhood of eight entries for the hashed index is check to find or update an already learned forwarding rule.
16	Optional A neighborhood of sixteen entries is used to store a learned entry if the hashed entry is already used. A neighborhood of sixteen entries for the hashed index is check to find or update an already learned forwarding rule.

870

### 871 [2.5.11.2 A representative example for data flow requirements](#)

872 TSN domains in an industrial automation network for cyclic real-time traffic can span multiple  
873 Cyber-physical systems, which are connected by bridges. The following maximum quantities apply:

- 874 – Stations: 1024
- 875 – Network diameter: 64
- 876 – per PLC for Controller-to-Device (C2D) – one to one or one to many – communication:
  - 877 ○ 512 producer and 512 consumer data flows
  - 878 ○ 64 kByte Output und 64 kByte Input data

- 879 - per Device for Device-to-Device (D2D) – one to one or one to many – communication:  
 880     o 2 producer and 2 consumer data flows  
 881     o 1400 Byte per data flow  
 882 - per PLC for Controller-to-Controller (C2C) – one to one or one to many – communication:  
 883     o 64 producer and 64 consumer data flows  
 884     o 1400 Byte per data flow  
 885 - Example calculation for eight PLCs  
 886     →  $8 \times 512 \times 2 = 8192$  data flows for C2D communication  
 887     →  $8 \times 64 \times 2 = 1024$  data flows for C2C communication  
 888     →  $8 \times 64 \text{ kByte} \times 2 = 1024 \text{ kByte}$  data for C2D communication  
 889     →  $8 \times 64 \times 1400 \text{ Byte} \times 2 = 1400 \text{ kByte}$  data for C2C communication  
 890 - All above shown data flows may optionally be redundant for seamless switchover due to the  
 891 need for High Availability.  
 892

893 Application cycle times for the 512 producer and 512 consumer data flows differ and follow the  
 894 application process requirements.

895 E.g. 125  $\mu\text{s}$  for those used for control loops and 500  $\mu\text{s}$  to 512 ms for other application processes.  
 896 All may be used concurrently and may have frames sizes between 1 and 1440 bytes.

### 897 [2.5.11.3 A representative example of communication use cases](#)

898 IO Station – Controller (input direction)

- 899 - Up to 2000 published + subscribed signals (typically 100 – 500)  
 900 - Scan interval time: 0,5 ..100ms (typical 10ms)

901 Controller – Controller (inter-application)

- 902 - Up to 1000 published + subscribed signals (typically 100 – 250)  
 903 - Application task interval time: 10..1000ms (typical 100ms)  
 904 - Resulting Scan interval time: 5 ... 500 ms

905 Closing the loop within/across the controller

- 906 - Up to 2000 published + subscribed signals (typically 100 – 500)  
 907 - Application task interval time: 1..1000ms (typical 100ms)  
 908 - Resulting Scan interval time when spreading over controllers: 0,5 ... 500 ms

909 Controller – IO Station (output direction)

- 910 - Up to 2000 published + subscribed signals (typically 100 – 500)  
 911 - Application task interval time: 10..1000ms (typical 100ms)  
 912 - Resulting Scan interval time: 5 ... 500 ms  
 913

### 914 [2.5.11.4 "Fast" process applications](#)

915 The structure shown in Figure 1 applies. Figure 41 provides a logic station view.

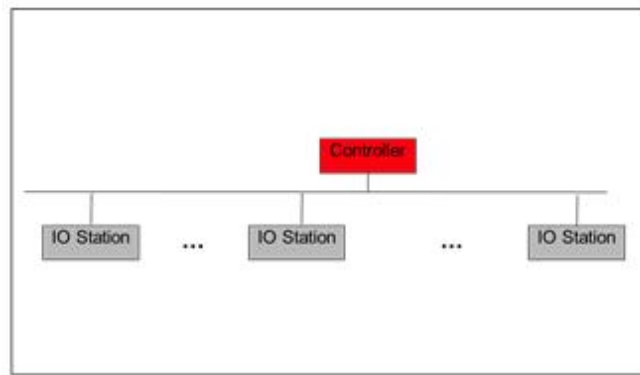

916

917

**Figure 41 – Logical communication concept for fast process applications**

918 Specifics:

- 919 – Limited number of nodes communicating with one Controller (e.g. Turbine Control)
- 920 – Up to a dozen Nodes of which typically one is a controller
- 921 – Data subscriptions (horizontal):
- 922 § 270 bytes published + subscribed per IO-station
- 923 § Scan Interval time 0,5 to 2 ms
- 924 – Physical Topology: Redundant (as path and as device)
- 925

#### 926 2.5.11.5 Server consolidation

927 The structure shown in Figure 1 applies. Figure 42 provides a logic station view.

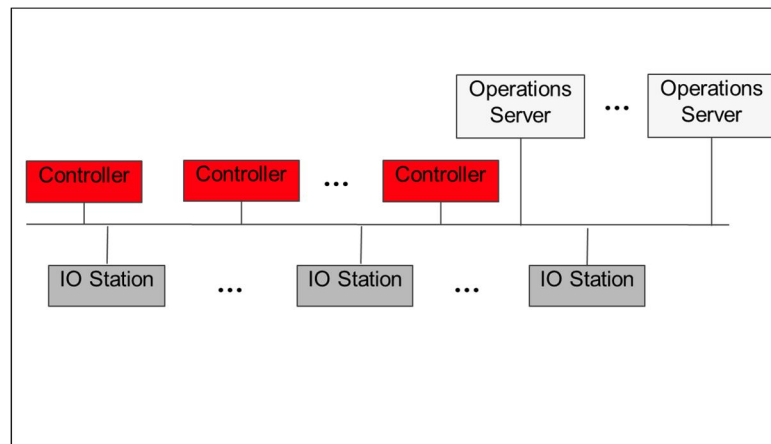

928

929

930

**Figure 42 – Server consolidated logical connectivity**

931 Data access to Operations Functionalities consolidated through Servers

- 932 – Up to 100 Nodes in total
- 933 – Out which are up to 25 Servers
- 934

935 Data subscriptions (vertical):

- 936 - Each station connected to at least 1 Server
- 937 - max. 20000 subscribed items per Controller/IO-station
- 938 - 1s update rate
- 939 - 50% analog items -> 30% change every sec

940

941 Different physical topologies

- 942 - Rings, stars, redundancy

943

944 [2.5.11.6 Direct client access](#)

945 The structure shown in Figure 1 applies. Figure 43 provides a logic station view.

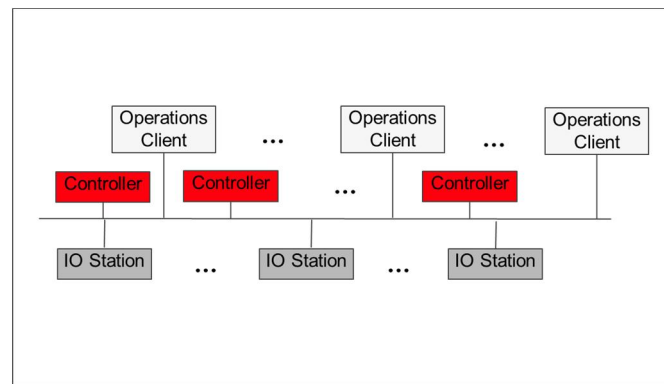

946

947 **Figure 43 – Clients logical connectivity view**

948 Data access to Operations Functionalities directly by Clients

- 949 - Max 20 direct access clients

950

951 Data subscriptions (vertical):

- 952 - Up to 3000 subscribed items per client
- 953 - 1s update rate
- 954 - Worst case 60000 items/second per controller in classical Client/Server setup
- 955 - 50% analog items -> 30% change every sec

956

957 Different physical topologies

- 958 - Rings, stars, redundancy

959

960 [2.5.11.7 Field devices](#)

961 The structure shown in Figure 1 applies. Figure 44 provides a logic station view.

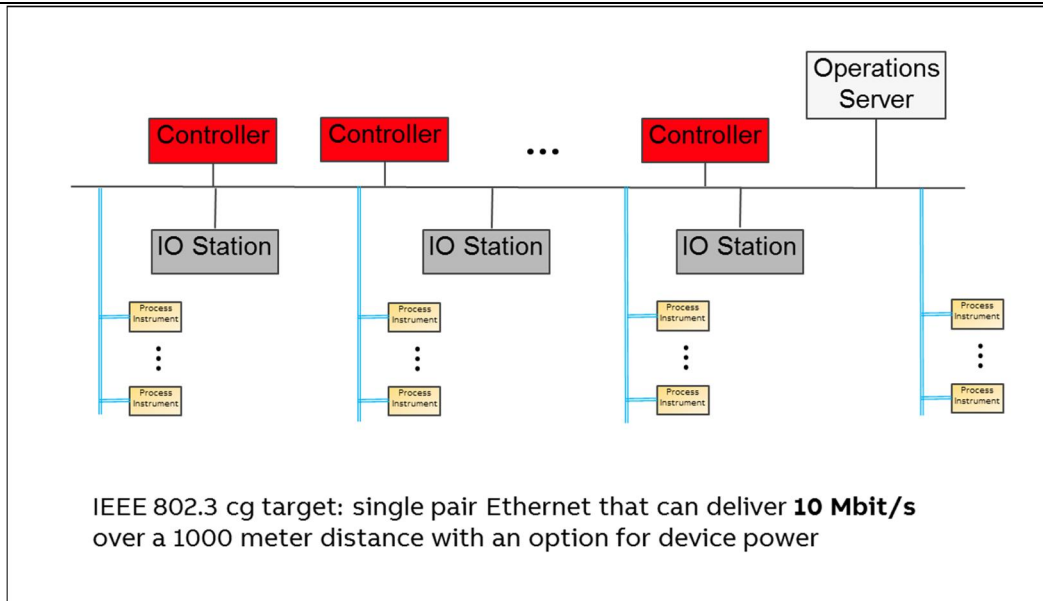

**Figure 44 – Field devices with 10Mbit/s**

962  
963  
964

965 Field Networks integrated with converged network

- 966 – Up to 50 devices per field segment
- 967 – Scan interval 50ms ... 1s, typical 250ms
- 968 – Mix of different device types from different vendors
- 969 – Many changes during runtime

970

971 [2.5.12 Bridge Resources](#)

972 The bridge shall provide and organize its resources in a way to ensure robustness for the traffic  
973 defined in this document as shown in Formula (1).

974 The queuing of frames needs resources to store them at the destination port. These resources may  
975 be organized either bridge globally, port globally or queue locally.

976 The chosen resource organization model influences the needed amount of frame resources.

977

978 For bridge memory calculation Formula (1) applies.

$$\text{MinimumFrameMemory} = (\text{NumberOfPorts} - 1) \times \text{MaxPortBlockingTime} \times \text{Linkspeed} \quad (1)$$

Where

<i>MinimumFrameMemory</i>	is minimum amount of frame buffer needed to avoid frame loss from non stream traffic due to streams blocking egress ports.
<i>NumberOfPorts</i>	is number of ports of the bridge without the management port.
<i>MaxPortBlockingTime</i>	is intended maximum blocking time of ports due to streams per millisecond.
<i>Linkspeed</i>	is intended link speed of the ports.

979

980 Formula (1) assumes that all ports use the same link speed and a bridge global frame resource  
981 management. Table 13, Table 14, Table 15, and Table 16 shows the resulting values for different  
982 link speeds.



983 The traffic from the management port to the network needs a fair share of the bridge resources to  
 984 ensure the required injection performance into the network. This memory (use for the real-time  
 985 frames) is not covered by this calculation.

986

**Table 13 – MinimumFrameMemory for 100 Mbit/s (50%@1 ms)**

# of ports	MinimumFrameMemory [KBytes]	Comment
1	0	The memory at the management port is not covered by Formula (1)
2	6,25	All frames received during the 50%@1 ms := 500 $\mu$ s at one port needed to be forwarded to the other port are stored during the allocation of this port due to stream transmission.
3	12,5	All frames received during the 50%@1 ms := 500 $\mu$ s at two ports needed to be forwarded to the other port are stored during the allocation of this port due to stream transmission.
4	18,75	All frames received during the 50%@1 ms := 500 $\mu$ s at three ports needed to be forwarded to the other port are stored during the allocation of this port due to stream transmission.
other	tbd	tbd

987

988

**Table 14 – MinimumFrameMemory for 1 Gbit/s (20%@1 ms)**

# of ports	MinimumFrameMemory [KBytes]	Comment
1	0	The memory at the management port is not covered by Formula (1)
2	25	All frames received during the 20%@1 ms := 200 $\mu$ s at one port needed to be forwarded to the other port are stored during the allocation of this port due to stream transmission.
3	50	All frames received during the 20%@1 ms := 200 $\mu$ s at two ports needed to be forwarded to the other port are stored during the allocation of this port due to stream transmission.
4	75	All frames received during the 20%@1 ms := 200 $\mu$ s at three ports needed to be forwarded to the other port are stored during the allocation of this port due to stream transmission.
other	tbd	tbd

989

990

**Table 15 – MinimumFrameMemory for 2,5 Gbit/s (10%@1 ms)**

# of ports	MinimumFrameMemory [KBytes]	Comment
1	0	The memory at the management port is not covered by Formula (1)
2	31,25	All frames received during the 10%@1 ms := 100 $\mu$ s at one port needed to be forwarded to the other port are stored during the allocation of this port due to stream transmission.
3	62,5	All frames received during the 10%@1 ms := 100 $\mu$ s at two ports needed to be forwarded to the other port are stored during the allocation of this port due to stream transmission.
4	93,75	All frames received during the 10%@1 ms := 100 $\mu$ s at three ports needed to be forwarded to the other port are stored during the allocation of this port due to stream transmission.
other	tbd	tbd

991

992

**Table 16 – MinimumFrameMemory for 10 Gbit/s (5%@1 ms)**

# of ports	MinimumFrameMemory [KBytes]	Comment
1	0	The memory at the management port is not covered by Formula (1)
2	62,5	All frames received during the 5%@1 ms := 50 $\mu$ s at one port needed to be forwarded to the other port are stored during the allocation of this port due to stream transmission.
3	125	All frames received during the 5%@1 ms := 50 $\mu$ s at two ports needed to be forwarded to the other port are stored during the allocation of this port due to stream transmission.
4	187,5	All frames received during the 5%@1 ms := 50 $\mu$ s at three ports needed to be forwarded to the other port are stored during the allocation of this port due to stream transmission.
other	tbd	tbd

993

994

A per port frame resource management leads to the same values, but reduces the flexibility to use free frame resources for other ports.

995

996

A per queue per port frame resource management would increase (multiplied by the number of to be covered queues) the needed amount of frame resources dramatically almost without any benefit.

997

998

999

Example “per port frame resource”:

100 Mbit/s, 2 Ports, and 6 queue

Needed memory := 6,25 KOctets \* 6 := 37,5 KOctets.

1000

1001

1002

No one is able to define which queue is needed during the “stream port blocking” period.

1003

1004

Bridged End-Station need to ensure that their local injected traffic does not overload the local bridge resources. Local network access must conform to the TSN-IA profile defined model with management defined limits and cycle times (see e.g. row Data period in Table 4).

1005

1006

## 1007 2.6 Industrial automation machines, production cells, production lines

1008 2.6.1 Use case 17: Machine to Machine/Controller to Controller (M2M/C2C) Communication  
 1009 Preconfigured machines with their own TSN domains, which include tested and approved internal  
 1010 communication, communicate with other preconfigured machines with their own TSN domains, with  
 1011 a supervisory PLC of the production cell (with its own TSN domain) or line (with its own TSN  
 1012 domain) or with an OS (Operator System) (with its own TSN domain).

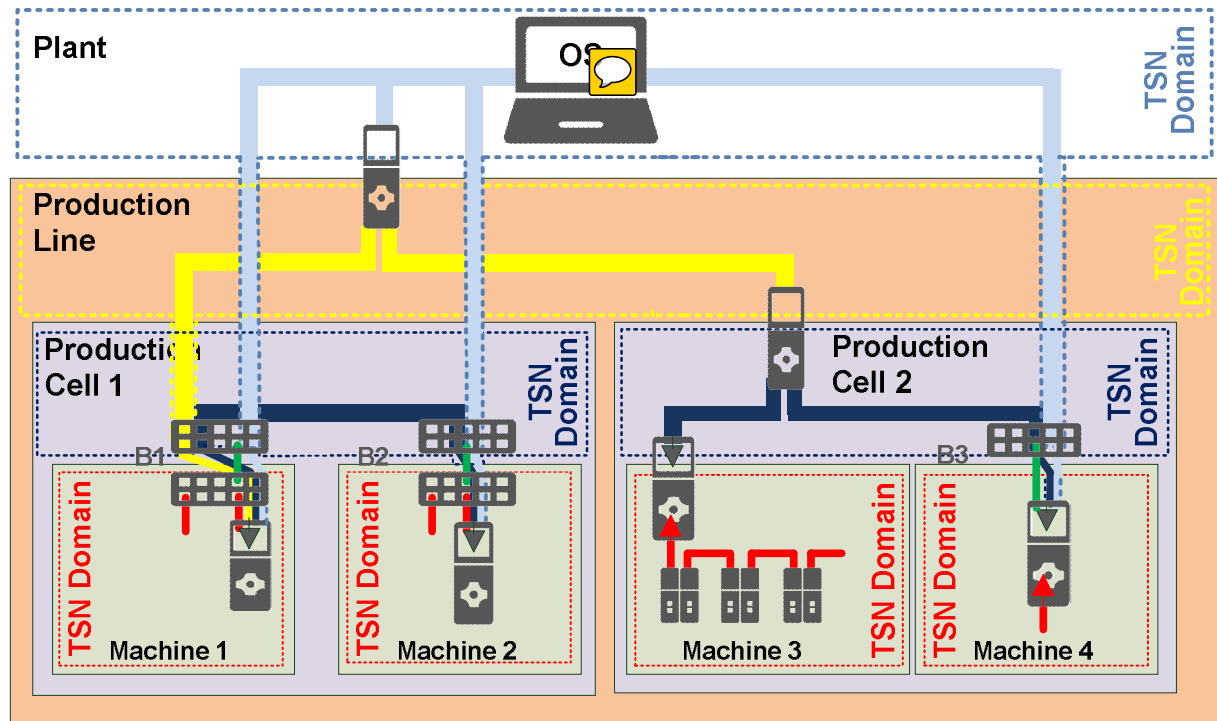

1013 **Figure 45 – M2M/C2C between TSN domains**  
 1014

1015 Figure 45 shows that multiple overlapping TSN Domains arise, when controllers use a single  
 1016 interface for the M2M communication with controllers of the cell, line, plant or other machines.  
 1017 Decoupling of the machine internal TSN Domain can be accomplished by applying a separate  
 1018 controller interface for M2M communication.

1019 Machine 1: the controller link to its connected cell bridge B1 is concurrently member of the TSN  
 1020 Domains of Machine 1, Production Cell 1, Production Line and Plant.

1021 Machine 2: the controller link to its connected cell bridge B2 is concurrently member of the TSN  
 1022 Domains of Machine 2, Production Cell 1 and Plant.

1023 Machine 3: the controller is directly attached to the PLC of Production Cell 2 and is therefore  
 1024 member of the TSN Domain of Production Cell 2. The machine internal TSN Domain is  
 1025 decoupled from M2M traffic by a separate interface.

1026 Machine 4: the controller link to its connected cell bridge B3 is concurrently member of the TSN  
 1027 Domains of Production Cell 2 and Plant. The machine internal TSN Domain is  
 1028 decoupled from M2M traffic by a separate interface.

1029  
 1030 Examples:  
 1031

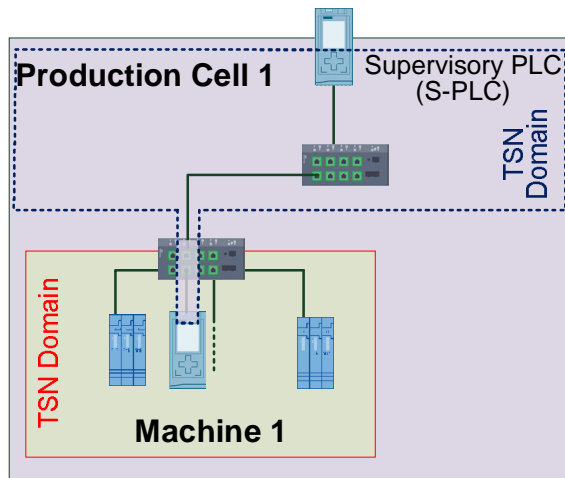

Figure 46 – M2M with supervisory PLC

Figure 46 gives an example of M2M communication to a supervisory PLC.

Figure 47 shows an example of M2M communication relations between four machines.

PLCs with one single interface lead to overlapping communication paths of M2M and machine internal traffic. In this case two TSN domains (Machine / Production cell) need to share resources due to two overlapping TSN domains.

Additionally Figure 48 shows an example where M2M communication is used to connect a PC for diagnostics/monitoring.

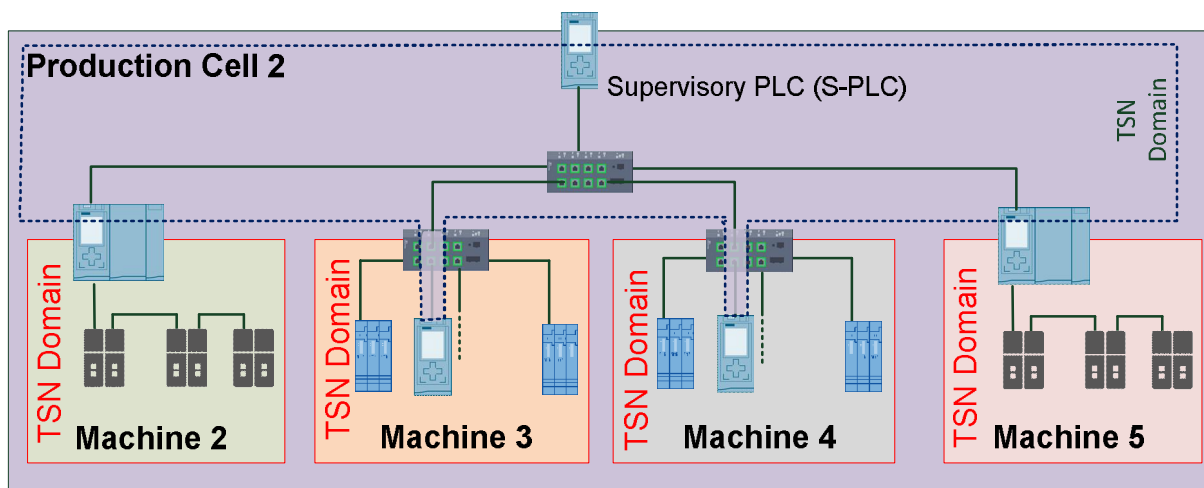

Figure 47 – M2M with four machines

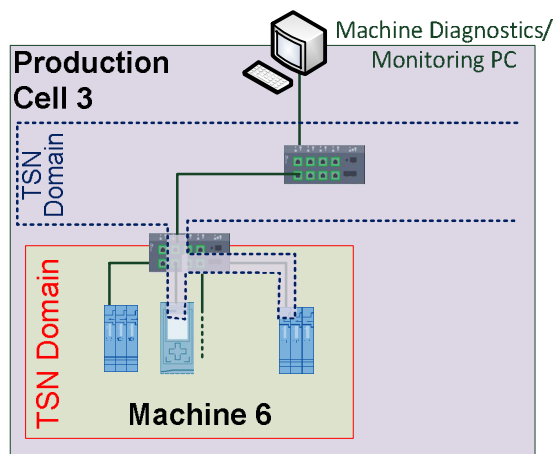

Figure 48 – M2M with diagnostics/monitoring PC

1032 Figure 48 shows a M2M diagnostics related use case: communication is cyclic and must happen  
 1033 within short application cycle times. An example of this use case is the verification of proper  
 1034 behavior of a follower drive, in a master-follower application. Today, the use case is covered by

1035 connecting a common PC to an interface of the follower drive. The various TSN mechanisms may  
 1036 now make it possible to connect such a PC network interface card anywhere in the system network  
 1037 and still gather the same diagnostics with the same guarantees, as the current direct connection.

1038 The required guarantees are:

1039 each 4 ms a frame must be sent from a follower drive and have its delivery guaranteed to the  
 1040 network interface of the PC used to perform the diagnostics. Of course, local PC-level processing  
 1041 of such frames has to be implemented such that the diagnostic application gets the required quality  
 1042 of service.

1043 From the communication point of view the two types of machine interface shown in Figure 47 are  
 1044 identical. The PLC represents the machine interface and uses either a dedicated (machine 1 and 4)  
 1045 or a shared interface (machine 2 and 3) for communication with other machines and/or a  
 1046 supervisor PLC.

1047 The communication relations between machines may or may not include or make use of a  
 1048 supervisory PLC.

1049 Requirement:

1050 All machine internal communication (stream traffic and non-stream traffic) is decoupled from and  
 1051 protected against the additional M2M traffic and vice versa.

1052 1:1 and 1:many communication relations shall be possible.

1053

1054 Useful 802 mechanisms:

- 1055 . 802.1Qbu, 802.1Qbv, 802.1Qci, Fixed priority, 802.3br
- 1056 . Priority Regeneration,
- 1057 . Queue-based resource allocation,
- 1058 . VLANs to separate TSN domains.

### 1059 2.6.2 Use case 18: Pass-through Traffic

1060 Machines are supplied by machine builders to production cell/line builders in tested and approved  
 1061 quality. At specific boundary ports standard devices (e.g. barcode reader) can be attached to the  
 1062 machines. The machines support transport of non-stream traffic through the tested/approved  
 1063 machine ("pass-through traffic") without influencing the operational behavior of the machine, e.g.  
 1064 connection of a printer or barcode reader. Figure 49, Figure 50 and Figure 51 give some examples  
 1065 of pass-through traffic installations in industrial automation.

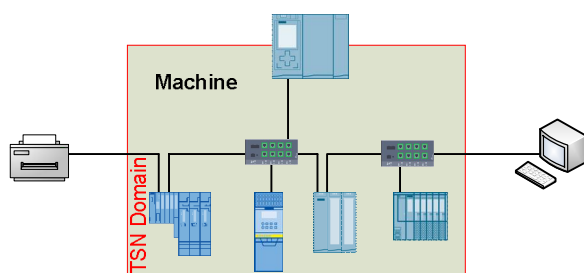

Figure 49 – pass-through one machine

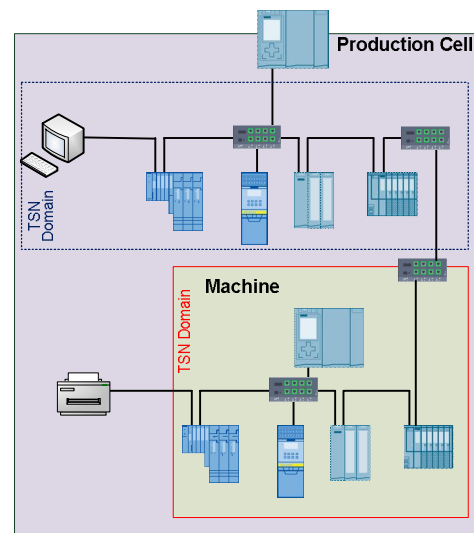
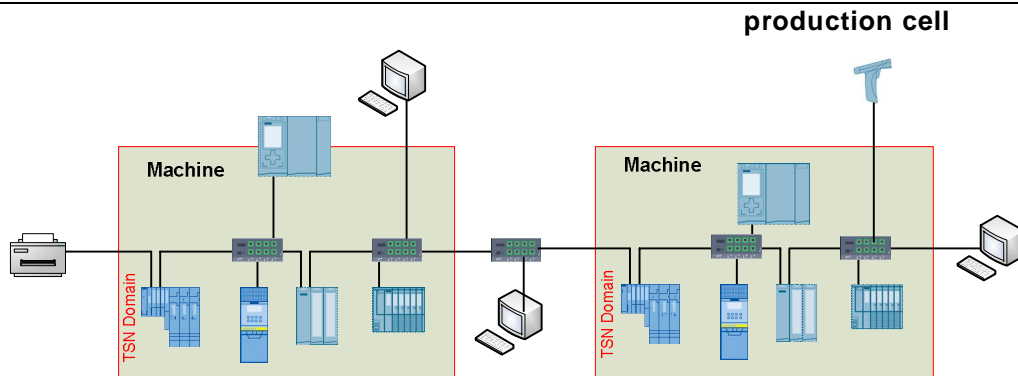
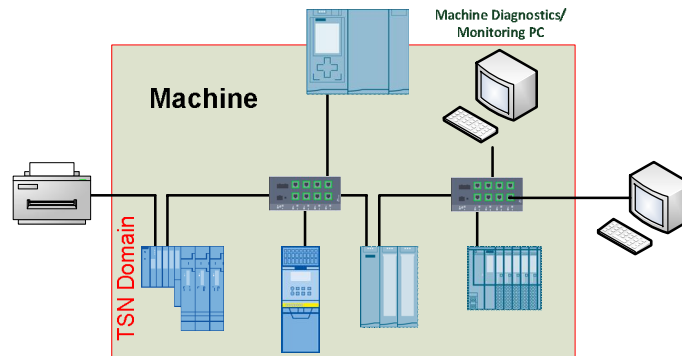

Figure 50 – pass-through one machine and



**Figure 51 – pass-through two machines**



**Figure 52 – machine with diagnostics / monitoring PC**

1066

Requirement:

1067 All machine internal communication (stream traffic and non-stream traffic) is decoupled from and  
 1068 protected against the additional “pass-through” traffic.  
 1069 “Pass-through” traffic is treated as separate traffic pattern.

1070

1071

Useful 802.1Q mechanisms:

1072

- Priority Regeneration,
- separate "pass-through traffic queue",
- Queue-based resource allocation in all bridges,
- Ingress rate limiting.

1073

1074

1075

1076

1077

[2.6.3 Use case 19: Modular machine assembly](#)

1078

In this use case machines are variable assemblies of multiple different modules. Effective  
 1079 assembly of a machine is executed in the plant dependent on the current stage of production, e.g.  
 1080 bread-machine with the modules: base module, ‘Kaisersemmel’ module, ‘Rosensemmel’ module,  
 1081 sesame caster, poppy-seed caster, baking oven OR advertisement feeder for newspapers.

1082

Figure 53 may have relaxed latency requirements, but the machine in Figure 54 needs to work with  
 1083 very high speed and thus has very demanding latency requirements.

1084

1084

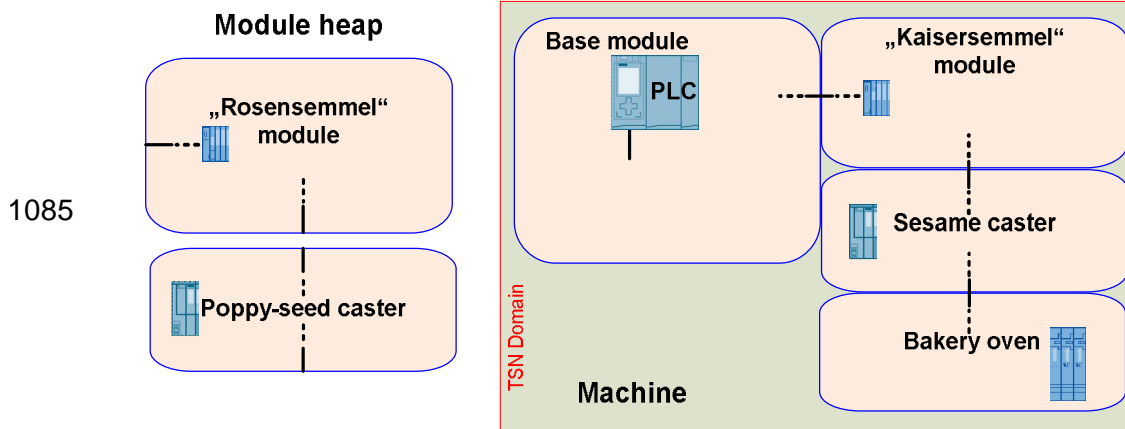

Figure 53 – modular bread-machine

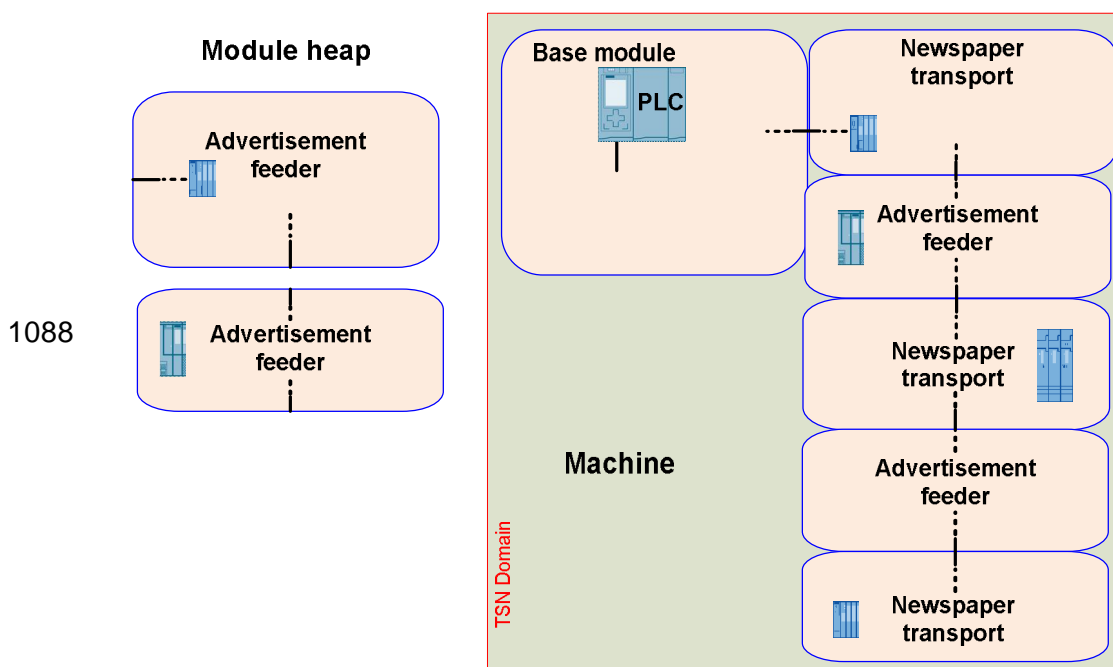

Figure 54 – modular advertisement feeder

1090 Requirement:

1091 Modules can be assembled to a working machine variably on-site (either in run, stop or power  
 1092 down mode) as necessary (several times throughout a day). The machine produces the selected  
 1093 variety of a product. Communication relying on TSN features is established automatically after the  
 1094 modules are plugged without management/ configuration interaction.

1096 2.6.4 Use case 20: Tool changer

1097 Tools (e.g. different robot arms) are in power off mode. During production a robot changes its arms  
 1098 for different production steps.

1099 They get mechanically connected to a robot arm and then powered on. The time till operate  
 1100 influences the efficiency of the robot and thus the production capacity of the plant. Robots may

1101 share a common tool pool. Thus the “tools” are connected to different robots during different  
 1102 production steps.

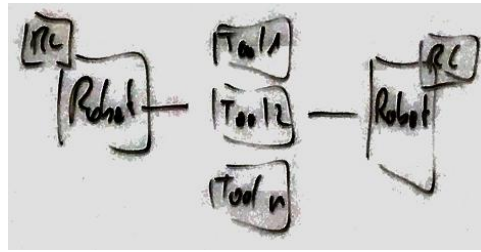

1103

1104

Figure 55 – tool changer

1105

1106

Requirement:

- 1107 · Added portion of the network needs to be up and running (power on to operate) in less than  
 1108 500ms.
- 1109 · Extending and removing portions of the network (up to 16 devices) in operation
  - 1110 ○ by one connection point (one robot using a tool)
  - 1111 ○ by multiple connection points (multiple robots using a tool)

1112

1113

1114

Useful 802.1Q mechanisms:

1115

1116

- preconfigured streams
- ...

1117

[2.6.5 Use case 21: Dynamic plugging and unplugging of machines \(subnets\)](#)

1118

1119

1120

E.g. multiple AGVs (automatic guided vehicles) access various docking stations to get access to the supervisory PLC. Thus, an AGV is temporary not available. An AGV may act as CPS or as a bunch of devices.

1121

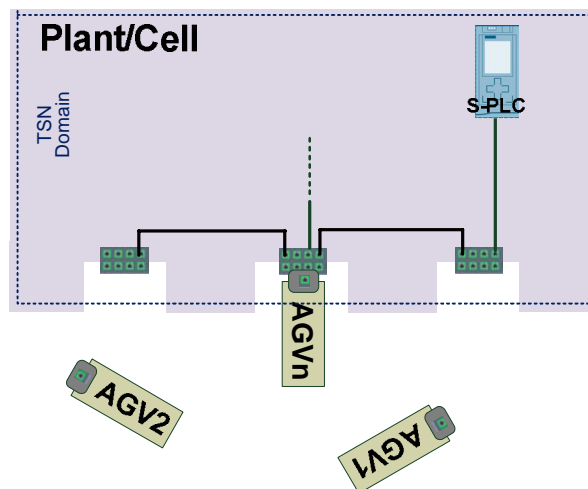

1122

1123

Figure 56 – AGV plug and unplug

1124

Requirement:

- 1125 The traffic relying on TSN features from/to AGVs is established/removed automatically after  
 1126 plug/unplug events.
- 1127 Different AGVs may demand different traffic layouts.



1128 The time till operate influences the efficiency of the plant.  
 1129 Thousands of AGS may be used concurrently, but only a defined amount of AGVs is connected at  
 1130 a given time.

1131

1132

1133 Useful 802.1Q mechanisms:

1134 · preconfigured streams

1135 · ...

1136

1137

1138 [2.6.6 Use case 22: Energy Saving](#)

1139 Complete or partial plant components are switched off and on as necessary to save energy. Thus,  
 1140 portions of the plant are temporarily not available.

1141

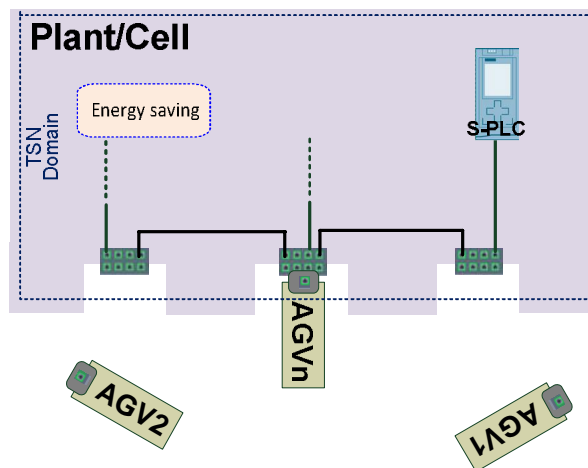

1142

**Figure 57 – energy saving**

1143 Requirement:

1144 Energy saving region switch off/on shall not create process disturbance.

1145 Communication paths through the energy saving area between end-stations, which do not belong  
 1146 to the energy saving area, shall be avoided.

1147

1148 Useful 802.1Q mechanisms:

1149 · Appropriate path computation by sorting streams to avoid streams passing through energy  
 1150 saving region.

1151 [2.6.7 Use case 23: Add machine, production cell or production line](#)

1152 When production capacity is exhausted, additional machines, production cells or even production  
 1153 lines are bought and integrated into a plant.

1154 E.g. an additional welding robot is added to a production cell to increase production capacity. The  
 1155 additional machine has to be integrated into the production cell control with minimal disturbance of  
 1156 the production cell process.

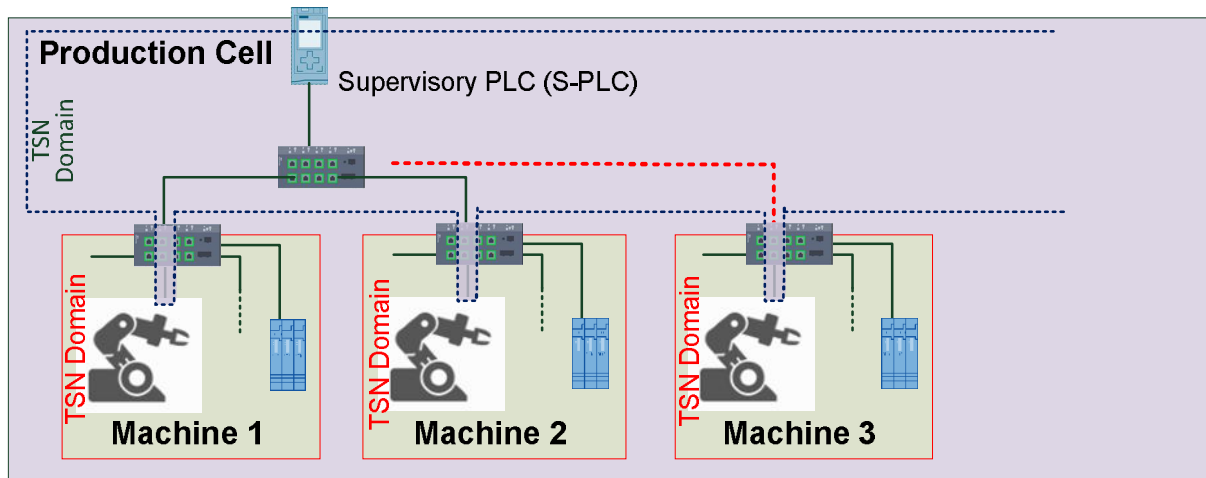

1157

1158

**Figure 58 – add machine**

1159

Requirement:

1160

Adding a machine/cell/production line shall not disturb existing installations

1161

1162

Useful mechanisms:

1163

· ...

1164

1165

[2.6.8 Use case 24: Multiple applications in a station using the TSN-IA profile](#)

1166

E.g. Technology A and B in PLC and devices.

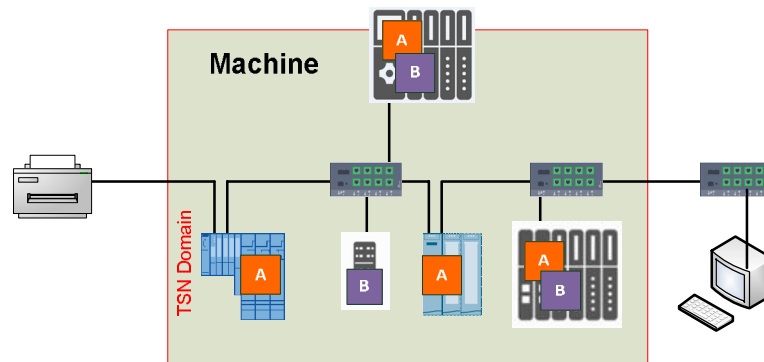

1167

1168

**Figure 59 – two applications**

1169

Requirement:

1171

Stations with multiple applications using TSN traffic classes shall be supported.

1172

1173

Useful 802.1 mechanisms:

1174

· ...

1175

[2.6.9 Use case 25: Functional safety](#)

1176

Functional safety is defined in IEC 61508 as *“part of the overall safety relating to the EUC*

1177

*[Equipment Under Control] and the EUC control system that depends on the correct functioning of*

1178 the E/E/PE [electrical/electronic/programmable electronic] safety-related systems and other risk  
 1179 reduction measures”

1180  
 1181 IEC 61784-3-3 defines a safety communication layer structure, which is performed by  
 1182 a standard transmission system (black channel), and an additional safety transmission protocol on  
 1183 top of this standard transmission system.

1184  
 1185 The standard transmission system includes the entire hardware of the transmission system and the  
 1186 related protocol functions (i.e. OSI layers 1, 2 and 7).

1187  
 1188 Safety applications and standard applications are sharing the same standard communication  
 1189 systems at the same time.

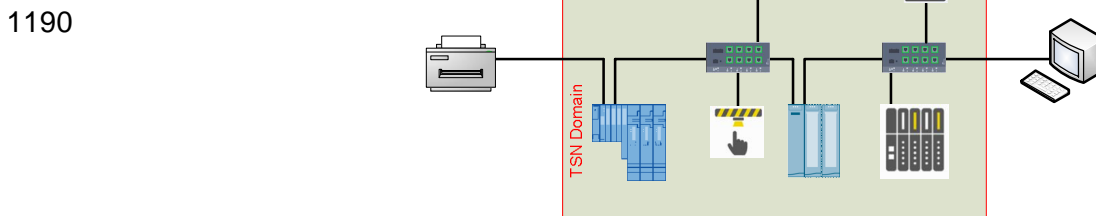

1191 **Figure 60 – Functional safety with cyclic real-time**

1192  
 1193 Requirement:

1194 Safety applications (as black channel) and standard applications share the same TSN-IA profile  
 1195 based communication system at the same time.

1196  
 1197 Useful 802.1 mechanisms:

1198 · ...

## 1199 2.7 DCS Reconfiguration

### 1200 2.7.1 Challenges of DCS Reconfiguration Use Cases

1201 The challenge these use cases bring is the influence of reconfiguration on the existing  
 1202 communication: all has to happen without disturbances to the production!

1203 We consider important the use case that we can connect any number of new devices wherever in  
 1204 the system and they get connectivity over the existing infrastructure supporting TSN features  
 1205 without a change to the operational mode of the system.

1206

### 1207 2.7.2 Use case 26: DCS Device level reconfiguration

1208 The structure shown in Figure 1 applies. Figure 61 provides a logic station view.

- 1209 · SW modifications to a device
- 1210 - A change to the device's SW/SW application shall happen, which does not require changes  
 1211 to the SW/SW application running on other devices (incl. firmware update): *add examples*
- 1212 · Device Exchange/Replacement

- 1213 - The process device is replaced by another unit for maintenance reason, e.g. for off-process  
 1214 calibration or because of the device being defective (note: a “defective device may still be  
 1215 fully and properly engaged in the network and the communication, e.g. if just the sensor is  
 1216 not working properly anymore):
- 1217 - Use case: repair
- 1218 · Add/remove additional device(s)
- 1219 - A new device is brought to an existing system or functionality, which shall be used in the  
 1220 application, is added to a running device, e.g. by enabling a SW function or plugging in a  
 1221 new HW-module. Even though the scope of change is not limited to a single device  
 1222 because also the other device engaged in the same application
- 1223 - For process devices, servers: BIOS, OS and applications updates, new VMs, workstations
- 1224 - Use cases: replacement with upgrade/downgrade of an existing device, simply adding new  
 1225 devices, removal of device, adding connections between devices
- 1226 · Influencing factors relative to communication
- 1227 - Communication requirements of newly added devices (in case of adding)
- 1228 - Existing QoS parameters (i.e. protocol-specific parameters like TimeOuts or Retries)
- 1229 - Device Redundancy
- 1230 - Network/Media Redundancy
- 1231 - Virtualization
- 1232 - For servers: in-premise or cloud
- 1233 - Clock types in the involved process devices
- 1234 - Universal time and working clock domains
- 1235 - Cycle time(s) needed by new devices
- 1236 - Available bandwidth
- 1237 - Existing security policies

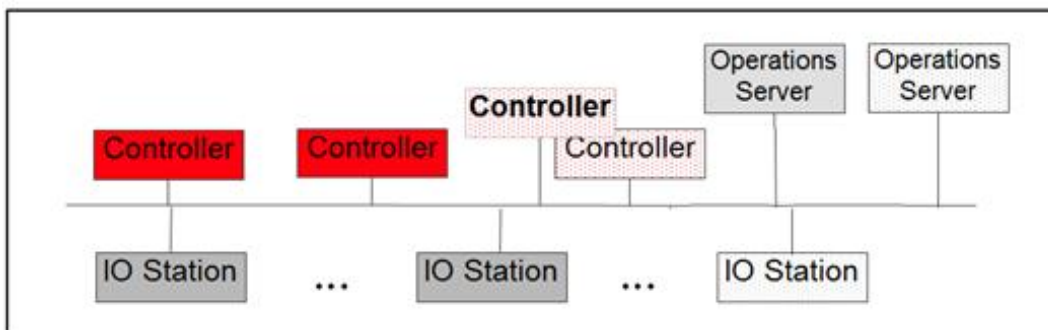

1238  
 1239 **Figure 61 – Device level reconfiguration use cases**

1240 [2.7.3 Use case 27: DSC System level reconfiguration](#)

1241 The structure shown in Figure 1 applies. Figure 62 provides a logic station view.

- 1242 · Extend an existing plant
- 1243 - Add new network segment to existing network
- 1244 - Existing non-TSN / Newly added is TSN
- 1245 - Existing TSN / Newly added is TSN
- 1246 · Update the system security policy
- 1247 - [New key lengths, new security zones, new security policy]
- 1248 - To be defined how and by whom to be handled
- 1249 · Influencing factors

1250 - Same as for "device-level"

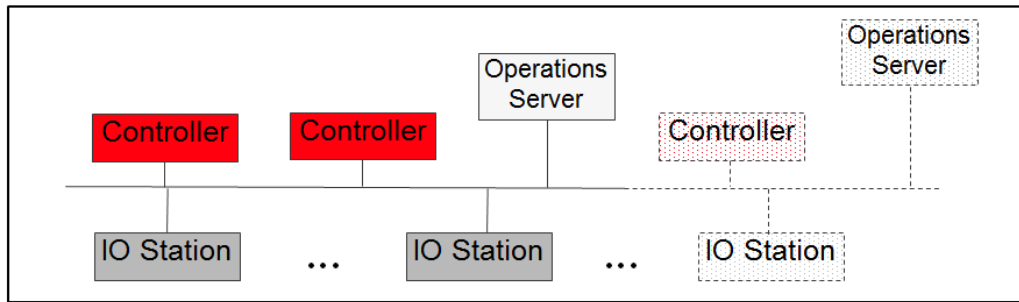

1251

1252

**Figure 62 – System level reconfiguration use cases**

## 1253 2.8 Further Industrial Automation Use Cases

### 1254 2.8.1 Use case 28: Network monitoring and diagnostics

1255 Diagnostics plays an important role in the management of systems and of devices. Generally  
 1256 speaking the mechanisms used in this context are acyclic or having large cycle times so that they  
 1257 could perhaps be considered, from a networking perspective as sporadic. Most of the use cases  
 1258 related to diagnostics will be included in this category.

- 1259 - Quick identification of error locations is important to minimize downtimes in production.
- 1260 - Monitoring network performance is a means to anticipate problems so that arrangements can  
 1261 be planned and put into practice even before errors and downtimes occur.
- 1262 - Identification of devices on an industrial Ethernet network must be done in a common,  
 1263 interoperable manner for interoperability on a converged TSN network. This identification both  
 1264 needs to show the type of device, and the topology of the network. IEEE 802.1AB, the Link  
 1265 Layer Discovery Protocol (LLDP), provides one possible mechanism for this to be done at layer  
 1266 two, but provides a large degree of variability in implementation.

1267

1268

#### Requirement:

1269 Minimize downtime

1270 Monitoring and diagnostics data including used TSN features shall be provided, e.g. established  
 1271 streams, failed streams, stream classes, bandwidth consumption, ...

1272 A discovery protocol such as IEEE 802.1AB shall be leveraged to meet the needs of TSN-IA.

1273

1274

1275

#### Useful 802.1 (ietf) mechanisms:

- 1276 · MIBs (SNMP)
- 1277 · YANG (NETCONF/RESTCONF)

1278

### 1279 2.8.2 Use case 29: Security

1280 Industrial automation equipment can become the objective of sabotage or spying.

1281 Therefore all aspects of information security can be found in industrial automation as well:

- 1282 · Confidentiality "is the property, that information is not made available or disclosed to  
 1283 unauthorized individuals, entities, or processes."
- 1284 · Integrity means maintaining and assuring the accuracy and completeness of data.

- 1285       · Availability implies that all resources and functional units are available and functioning  
1286       correctly when they are needed. Availability includes protection against denial-of-service  
1287       attacks.
- 1288       · Authenticity aims at the verifiability and reliability of data sources and sinks.

1289  
1290 Requirement:

1291 Optional support of confidentiality, integrity, availability and authenticity.

1292 Security shall not limit real-time communication

1293

1294 Protection against rogue applications running on authenticated stations are out of scope.

1295

1296 Useful mechanisms:

1297       · 802.1X

1298       · IEC62443

1299       · ...

### 1300 [2.8.3 Use case 30: Firmware update](#)

1301 Firmware update is done during normal operation to make sure that the machine e.g. with 1000  
1302 devices is able be updated with almost no down time.

1303

1304 With bump: separate loading (space for 2 FW versions required) and coordinated activation to  
1305 minimize downtime

1306

1307 Bumpless: redundant stations with bumpless switchover – the single device may lose connection  
1308 (bump)

1309

1310 Requirement:

1311 Stations shall be capable to accept and store an additional fw version without disturbance.

1312

1313 Useful 802.1 mechanisms:

1314       · ...

### 1315 [2.8.4 Use case 31: Virtualization](#)

1316 Workload consolidation is done by virtualizing the hardware interfaces. Even in such kind of  
1317 environment the TSN features according to the TSN-IA profile shall be available and working.

1318

#### 1319 **vSwitch / vBridge**

1320

1321 Figure 63 and Figure 64 show the two principle setups for an Ethernet communication concept  
1322 allowing both, communication VM to Ethernet and VM to VM. The applications inside the VM shall  
1323 not see, whether they communicate to another VM or an Ethernet node.

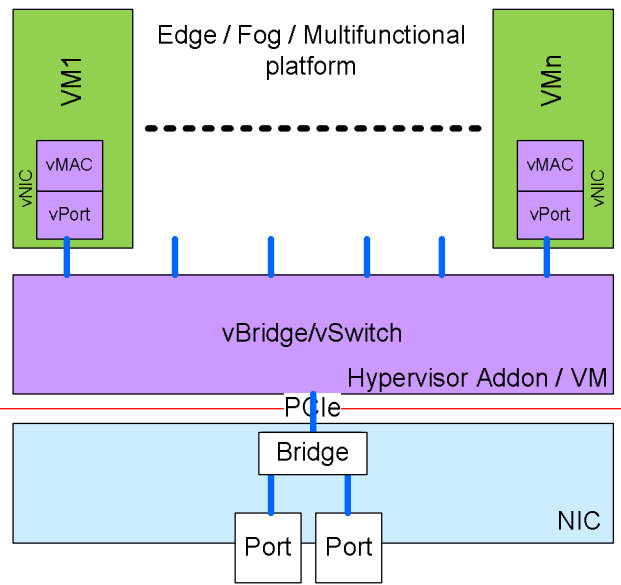

1324

1325

**Figure 63 – Ethernet interconnect with VM based vBridge**

1326

1327

Figure 63 scales for an almost infinite amount of VMs, because the memory bandwidth and the compute power of the vMAC/vPort and vSwitch/vBridge VM are much higher than the PCIe bandwidth to the NIC.

1328

1329

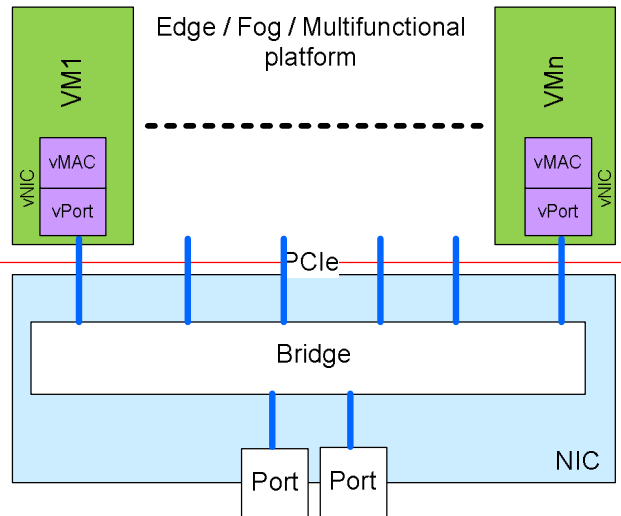

1330

1331

**Figure 64 – Ethernet interconnect with PCIe connected Bridge**

1332

1333

Figure 64 fits for a limited amount of VMs, because it saves the additional vSwitch/vBridge VM. For a given amount of VMs, e.g. Gen3 x4 or Gen4 x4, seems to be sufficient.

1334

1335

1336

Requirement:

1337

vBridge and vPort should behave as real Bridge and real Port: data plane, control plane, ...

1338

vBridge and vPort can become members of TSN domains.

1339

Should work like use case “multiple applications”

1340

1341 Useful 802.1 mechanisms:

1342     · ...  
1343

### 1344 2.8.5 Use case 32: Digital twin

1345 Virtual pre-commissioning of machines can save a lot of time and money.  
1346 Up to 30 % time-saving in the development of new machines are foreseen by an increased  
1347 engineering efficiency due to the implementation and usage of digital twins.  
1348 Faster development, delivery and commissioning of new machines at customer locations should be  
1349 possible.

1351 A digital twin shows the real machine in as much detail as possible and allows simulation of its  
1352 operation. With the help of digital twins machines can gradually and virtually be developed – in  
1353 parallel to the real production and commissioning process of the machines at customer locations.

1354 Requirement:

1355 Reliable planning, development, testing, simulation and optimization results shall be possible

1356 Useful 802.1 mechanisms:

1357     · ...  
1358

### 1360 2.8.6 Use case 33: Device replacement without engineering

1361 Any device in a plant, i.e. end-station, bridged end-station or bridge, may get broken eventually. If  
1362 this happens fast and simple replacement of a broken device is necessary to keep production  
1363 disturbance at a minimum (see also: 2.7.2 Use case 26: DCS Device level reconfiguration).  
1364 Support of “mechanical” replacement of a failed device with a new one without any engineering  
1365 effort (i.e. without the need for an engineering tool) is a prerequisite for minimal repair downtime.

1366 Requirement:

1367 In case of repair it shall be possible to replace end-stations, bridged end-stations or brides without  
1368 the need of an engineering tool.

1369 Useful 802.1 mechanisms:

1370     · ...  
1371

## 1374 3 Literature

1375 [1] “Cyber Physical Systems: Design Challenges”, E. A. Lee, Technical Report No. UCB/EECS-  
1376 2008-8; <http://www.eecs.berkeley.edu/Pubs/TechRpts/2008/EECS-2008-8.html>

1377 [2] Beckers, K. (2015). Pattern and Security Requirements: Engineering-Based Establishment of  
1378 Security Standards; Springer; ISBN 9783319166643

1379 [3] PI: Isochronous Mode – Guideline for PROFINET IO; V1.0; June 2016; available at  
1380 <http://www.ieee802.org/1/files/private/liaisons>

1381  
1382  
1383  
1384