

ETSI ES 203 178 V1.1.1 (2015-02)



ETSI STANDARD

**Functional architecture to support European requirements
on emergency caller location determination and transport**

ReferenceDES/E2NA-00001-M493-stage2

Keywordsemergency, location, VoIP

ETSI

650 Route des Lucioles
F-06921 Sophia Antipolis Cedex - FRANCE

Tel.: +33 4 92 94 42 00 Fax: +33 4 93 65 47 16

Siret N° 348 623 562 00017 - NAF 742 C
Association à but non lucratif enregistrée à la
Sous-Préfecture de Grasse (06) N° 7803/88

Important notice

The present document can be downloaded from:

<http://www.etsi.org/standards-search>

The present document may be made available in electronic versions and/or in print. The content of any electronic and/or print versions of the present document shall not be modified without the prior written authorization of ETSI. In case of any existing or perceived difference in contents between such versions and/or in print, the only prevailing document is the print of the Portable Document Format (PDF) version kept on a specific network drive within ETSI Secretariat.

Users of the present document should be aware that the document may be subject to revision or change of status. Information on the current status of this and other ETSI documents is available at

<http://portal.etsi.org/tb/status/status.asp>

If you find errors in the present document, please send your comment to one of the following services:

<https://portal.etsi.org/People/CommitteeSupportStaff.aspx>

Copyright Notification

No part may be reproduced or utilized in any form or by any means, electronic or mechanical, including photocopying and microfilm except as authorized by written permission of ETSI.

The content of the PDF version shall not be modified without the written authorization of ETSI.

The copyright and the foregoing restriction extend to reproduction in all media.

© European Telecommunications Standards Institute 2015.

All rights reserved.

DECT™, **PLUGTESTS™**, **UMTS™** and the ETSI logo are Trade Marks of ETSI registered for the benefit of its Members. **3GPP™** and **LTE™** are Trade Marks of ETSI registered for the benefit of its Members and of the 3GPP Organizational Partners.

GSM® and the GSM logo are Trade Marks registered and owned by the GSM Association.

Contents

Intellectual Property Rights	5
Foreword.....	5
Modal verbs terminology.....	5
1 Scope	6
2 References	6
2.1 Normative references	6
2.2 Informative references.....	6
3 Definitions and abbreviations.....	7
3.1 Definitions.....	7
3.2 Abbreviations	9
4 Descriptions and assumptions	9
4.1 Introduction	9
4.2 Location information descriptions.....	10
4.2.1 General.....	10
4.2.2 Location value	10
4.2.3 Location identifier.....	10
4.2.4 Location reference	11
5 Functional architecture to support European requirements on emergency caller location determination and transport.....	11
5.1 Overview	11
5.2 Architectural requirements	12
5.2.1 General.....	12
5.2.2 ANP - Access Network Provider	13
5.2.3 VSP - Voice Service Provider.....	13
5.2.4 ECSP - Emergency Call Service Provider	13
5.2.5 PSP - PSAP Service Provider	14
5.3 Interfaces	14
5.3.1 Interface definitions	14
5.3.2 Information flows	16
5.3.2.1 ia interface.....	16
5.3.2.2 ib interface.....	17
5.3.2.3 ic interface.....	17
5.3.2.4 id interface.....	18
5.3.2.5 ie interface.....	18
5.3.2.6 if interface	18
5.3.2.7 ig interface.....	19
5.3.2.8 ih interface.....	19
5.3.2.9 ii interface	20
5.3.2.10 ij interface	21
5.3.2.11 ik interface.....	22
5.3.2.12 il interface	22
5.3.2.13 im interface	23
5.3.2.14 in interface.....	23
5.4 Functional entities	24
5.4.1 ANP	24
5.4.1.1 Location Server (LS).....	24
5.4.2 VSP.....	25
5.4.2.1 VSP Call Control	25
5.4.3 ECSP.....	26
5.4.3.1 ESRF.....	26
5.4.3.2 LS Proxy	26
5.4.3.3 Other entities	26
5.4.4 PSAP Service Provider	27

5.4.4.1	Emergency Service Routing Proxy.....	27
5.4.4.2	Route Server.....	27
5.4.4.3	Other entities.....	27
5.4.5	other functional entities	28
5.4.5.1	Location Server Discovery Function.....	28
5.4.5.2	User Equipment.....	28
5.4.5.3	IP-PSAP.....	28
5.4.5.4	PSTN-PSAP.....	28
5.5	Information flow diagrams.....	29
5.5.1	Introduction.....	29
5.5.2	ANP provides a location value	29
5.5.3	ANP provides location reference to the VSP and the ECSP pulls location value.....	31
5.5.4	ANP provides to the VSP a location identifier	32
5.5.5	ANP provides location identifier to the VSP and the PSAP pulls location value	34
5.6	Extension of the Functional Architecture for Networks with VPN, NAT/PAT and other components which change Packet Flow Identity.....	35
5.7	Extension of the Functional Architecture to support VSP Aggregation Providers.....	35
6	Protocol and other requirements.....	36
6.1	Generic requirements	36
6.2	Trust relationships	36
Annex A (normative): Extension of the Functional Architecture for Networks with VPN, NAT/PAT and other components which change Packet Flow Identity		37
A.1	General	37
A.2	LS chaining solution.....	37
A.2.1	Location chaining interface impacts.....	39
A.3	HOST_ID solution	39
Annex B (informative): M/493 Scope		43
Annex C (normative): Extension of the Functional Architecture to support an aggregating VSP.....		44
C.1	General	44
C.2	Architectural requirements for VSP Aggregation Provider (VAP).....	44
C.3	Extended Interface definition	45
C.4	VSP Aggregating Entity.....	45
Annex D (informative): Avoiding authentication between the VSP and the ANP.....		46
History		48

Intellectual Property Rights

IPRs essential or potentially essential to the present document may have been declared to ETSI. The information pertaining to these essential IPRs, if any, is publicly available for **ETSI members and non-members**, and can be found in ETSI SR 000 314: *"Intellectual Property Rights (IPRs); Essential, or potentially Essential, IPRs notified to ETSI in respect of ETSI standards"*, which is available from the ETSI Secretariat. Latest updates are available on the ETSI Web server (<http://ipr.etsi.org>).

Pursuant to the ETSI IPR Policy, no investigation, including IPR searches, has been carried out by ETSI. No guarantee can be given as to the existence of other IPRs not referenced in ETSI SR 000 314 (or the updates on the ETSI Web server) which are, or may be, or may become, essential to the present document.

Foreword

This ETSI Standard (ES) has been produced by ETSI Project End-to-End Network Architectures (E2NA).

Modal verbs terminology

In the present document "**shall**", "**shall not**", "**should**", "**should not**", "**may**", "**need not**", "**will**", "**will not**", "**can**" and "**cannot**" are to be interpreted as described in clause 3.2 of the [ETSI Drafting Rules](#) (Verbal forms for the expression of provisions).

"**must**" and "**must not**" are **NOT** allowed in ETSI deliverables except when used in direct citation.

1 Scope

The present document describes the unified functional architecture to support requirements as outlined in European Commission (EC) mandate M/493 [i.4] on emergency caller location determination and transport, in particular for the case where the VoIP service provider and one or several network operators - all serving the customer in the establishment of an emergency call - are independent enterprises needing to co-operate to determine the location of the (nomadic) caller. The architecture identifies all necessary interfaces, which are needed to fulfil the requirements outlined in EC Mandate M/493 [i.4], and provides a basis for the specification of the protocols to be used on those interfaces.

The present document is applicable to both NGN and pre-NGN IP-based networks. The architecture defined in the present document is intended to be compatible with IMS-based deployments but does not require compliance to IMS specifications.

This architecture does not intend to replace existing deployed solutions. It should enable operators and undertakings providing services to realize transmission of location information to the Public Safety Answering Point.

2 References

2.1 Normative references

References are either specific (identified by date of publication and/or edition number or version number) or non-specific. For specific references, only the cited version applies. For non-specific references, the latest version of the reference document (including any amendments) applies.

Referenced documents which are not found to be publicly available in the expected location might be found at <http://docbox.etsi.org/Reference>.

NOTE: While any hyperlinks included in this clause were valid at the time of publication, ETSI cannot guarantee their long term validity.

The following referenced documents are necessary for the application of the present document.

Not applicable.

2.2 Informative references

References are either specific (identified by date of publication and/or edition number or version number) or non-specific. For specific references, only the cited version applies. For non-specific references, the latest version of the reference document (including any amendments) applies.

NOTE: While any hyperlinks included in this clause were valid at the time of publication, ETSI cannot guarantee their long term validity.

The following referenced documents are not necessary for the application of the present document but they assist the user with regard to a particular subject area.

- [i.1] ETSI TS 123 167: "Universal Mobile Telecommunications System (UMTS); LTE; IP Multimedia Subsystem (IMS) emergency sessions (3GPP TS 23.167)".
- [i.2] IETF RFC 6967: "Analysis of Potential Solutions for Revealing a Host Identifier (HOST-ID) in Shared Address Deployments".
- [i.3] Draft-boucadair-intarea-host-identifier-scenarios-03 (March 2013): "Host Identification: Use Cases".
- [i.4] M/493: "Standardisation Mandate to the European Standards Organisations (ESO) in support of the location enhanced emergency call service".

- [i.5] IETF RFC 6753: "A Location Dereference Protocol Using HTTP-Enabled Location Delivery (HELD)".
- [i.6] ETSI TS 102 181: "Emergency Communications (EMTEL); Requirements for communication between authorities/organizations during emergencies".
- [i.7] ETSI TS 102 650: "Telecommunications and Internet converged Services and Protocols for Advanced Networking (TISPAN); Analysis of Location Information Standards produced by various SDOs".
- [i.8] Directive 2002/22/EC of the European Parliament and of the Council of 7 March 2002 on universal service and users' rights relating to electronic communications networks and services (Universal Service Directive).
- [i.9] Commission Recommendation 2003/558/EC of 25 July 2003 on the processing of caller location information in electronic communication networks for the purpose of location-enhanced emergency call services (notified under document number C(2003)2657).
- [i.10] IETF RFC 5222: "LoST: A Location-to-Service Translation Protocol".
- [i.11] IETF RFC 4848: "Domain-Based Application Service Location Using URIs and the Dynamic Delegation Discovery Service (DDDS)".

3 Definitions and abbreviations

3.1 Definitions

For the purposes of the present document, the following terms and definitions apply:

access network: portion of the telecommunications network that provides access to the switching function and terminates the user access signalling

Access Network Provider (ANP): service provider that provides physical and IP connectivity to a user equipment (UE) via a fixed or mobile access

NOTE: The access network may be provided by a single organization or it may be provided by a number of different organizations, BUT the interfaces between these organizations are not relevant to the scope of the present document as it is matter of contractual relations between the parties.

emergency: urgent need for assistance or relief

emergency call: call from a user to an emergency call centre, PSAP or similar agency charged with routing calls to the relevant emergency response organization

emergency call facilities: mechanisms provided by public or private communications networks, emergency telephone stanchions/boxes, fire alarms, etc. the use of which enables emergency calls to be made

Emergency Call Service Provider (ECSP): service provider that acts as a mediator between the voice service providers and the public safety answering point service providers

emergency caller: individual placing an emergency call to reach the suitable PSAP

emergency response organization: local or national force established to provide assistance to citizens in the event of their being involved in an emergency situation and requiring specialized help, for example, the police, fire service and emergency medical services

emergency service: service that provides immediate and rapid assistance in situations where there is a direct risk to life or limb, individual or public health or safety, to private or public property, or the environment but not necessarily limited to these situations

emergency situation: abnormal situation of serious nature that develops suddenly and unexpectedly, of which the evolution is uncertain and which may turn into a crisis or cause damage and casualties

FlowChanger: device in an IP flow, which changes the packet flow identity, for example changing the IP address and/or port, so the UE can no longer be identified in the original access network

location identifier: public network identifier, which provides a location value

EXAMPLE: A cell ID or line ID (see ETSI TS 123 167 [i.1]).

NOTE: A location value can be obtained from a location identifier by applying a static mapping or the location identifier may be encoded in such a way that it contains a location value (e.g. a ZIP code).

location information: location value, and/or a location identifier and/or a location reference

location reference: identifies a location server and provides sufficient information to allow the location server to provide the location value for the UE

EXAMPLE: <https://ls.example.com:49152/uri/w3g61nf5n66p0>, IETF RFC 6753 [i.5].

location value: civic or geodetic position

network-provided location information: any location information pertaining to the calling device that is determined, provided or verified by the ANP

Next Generation Network (NGN): packet-based network able to provide telecommunication services and able to make use of multiple broadband, QoS-enabled transport technologies and in which service-related functions are independent from underlying transport-related technologies

nomadic: having the ability to move across network access points

NOTE: A nomadic user can make calls from different locations. However, unlike a mobile user, the location of a nomadic user cannot change during a specific call.

originating network: access network in which the emergency call was placed

packet flow identity: all network parameters, which unambiguously identify a IP flow

PSAP address: URI or an E.164 number identifying a PSAP or a group of PSAPs

PSAP Service Provider: service provider that provides connectivity to Public Safety Answering Points (PSAPs) and directs emergency calls from the ECSP to the PSAP

Public Safety Answering Point (PSAP): physical location where emergency calls are received under the responsibility of a public authority

NOTE: See Commission Recommendation C(2003)2657 [i.9] and ETSI TS 102 181 [i.6].

regulatory domain: geographical area where a set of regulatory rules applies

telecommunication: any transmission, emission, or reception of signs, signals, writing, images, sounds or intelligence of any nature, by wire, radio, optical fibre or other electromagnetic system

user access: point of connection to a telecommunication network from which a call can be placed

NOTE: This includes public telephones and "emergency call facilities".

user equipment: device allowing a user access to network services

user-provided location information: any location information originating from user-equipment that is not independently verified by the ANP

Voice Service Provider (VSP): specific type of application service provider that provides voice related services and optionally text and video-related services, on IP

VSP Aggregation Provider (VAP): provider that a VSP or group of VSPs can use to support call routing to remote ECSPs and for the generation of related call data records

3.2 Abbreviations

For the purposes of the present document, the following abbreviations apply:

ANP	Access Network Provider
AP	Access Point
CGN	Carrier Grade NAT
DHCP	Dynamic Host Configuration Protocol
DNS	Domain Name Server
EC	European Commission
ECSP	Emergency Call Service Provider
ESO	European Standards Organization
ESRF	Emergency Service Routing Function
ESRP	Emergency Service Routeing Proxy
ETSI	European Telecommunications Standards Institute
FID	Flow Identity
FID-N	N th Flow Identity
FQDN	Fully Qualified Domain Name
IETF	Internet Engineering Task Force
IMS	IP Multimedia Subsystem
IP	Internet Protocol
ISDN	Integrated Services Digital Network
LS	Location Server
LS-N	N th Location Server
NAPTR	Naming Authority Pointer
NAT	Network Address Translation
NGN	Next Generation Network
PAT	Port and Address Translation
PBX	Private Branch Exchange
PCRF	Policy and Charging Rules Function
PSAP	Public Safety Answering Point
PSP	PSAP Service Provider
PSTN	Public Switched Telephone Network
RFC	Request For Comment
SIP	Session Initiation Protocol
TCP	Transmission Control Protocol
UDP	User Datagram Protocol
UE	User Equipment
URI	Uniform Resource Identifier
VAE	VSP Aggregating Entity
VAP	VSP Aggregation Provider
VoIP	Voice over Internet Protocol
VPN	Virtual Private Network
VSP	Voice Service Provider

4 Descriptions and assumptions

4.1 Introduction

ETSI TS 102 650 [i.7] states that:

"In order to effectively deliver emergency services to the location of a reported incident, it is essential for the emergency response organization to have timely and accurate information that enables them to correctly identify the location of the incident.

The ability to initiate an emergency communication to summon help when needed is regarded by the European Commission as a right of all citizens and this ability should ideally be independent of the network and access technologies deployed or the physical abilities of the citizen.

The rights of individual users to privacy shall be adhered to according to European regulations and it is therefore essential that all information derived from emergency calls shall only be used for management of the related incident. Location information for non-emergency calls is out of scope of the present document.

In many circumstances, citizens reporting an incident requiring urgent assistance are unable to provide the emergency service with accurate information about the location of the emergency. This may be due either due to the nature of the emergency, the callers' lack of local knowledge, their disabilities or lack of linguistic ability, etc. Young children or cognitively impaired people may not have the language skills to explain their location, speech and/or hearing impaired users may not be able to use voice terminals, visually impaired or otherwise disabled people may not be able to use text terminals, elderly or confused people may not be able to use any form of terminal, etc. For these significantly large categories of users the successful outcome of an emergency call could make the difference between life and death. It is therefore essential for the emergency responders to be provided with accurate location information via an automated process based on the communications network being used by the caller.

Implementation of caller location systems is also likely to result a welcome positive impact on the reduction of malicious calls made by criminal or anti-social persons when they realize that the automatic provision of their location information to the emergency services could enable their almost instant apprehension."

The M/493 standardization mandate [i.4] is issued on the basis of the European Regulatory Framework for the electronic communication networks and services. The Universal Service Directive, Article 26, Paragraph 2 states, that "Member States ... shall ensure that undertakings providing end-users with an electronic communications service for originating national calls to a number or numbers in a national telephone numbering plan provide access to emergency services". This includes providing emergency caller location. The service addressed by the Universal Service Directive includes telephony and any publicly available voice service using E.164 numbers, independently from the specific network technology (i.e. traditional or VoIP network technologies). The architecture in the present document includes provisions for the universal service directive obligations as described above and emergency calling using emergency service URNs.

The scope of the M/493 mandate [i.4] is directly reproduced in annex B.

4.2 Location information descriptions

4.2.1 General

Location information is crucial in emergency calling in determining which PSAP needs to receive the call and also where to dispatch emergency crews to ensure that help is received where it is needed. The definition clause of the present document defines three types of location information, a location value, a location identifier and a location reference. Each of the location information types represents a different kind of information about the caller's location and each can be used by the emergency call service in a different way.

4.2.2 Location value

A location value describes a physical area in which the caller is likely to be present. This may be a civic location, which describes some kind of street address, or it may be represented as a geodetic location, which uses latitude, longitude and uncertainty parameters that result in the defining of an area or volume.

However, a location value that is accurate enough to allow routing of a call to the correct PSAP may not be good enough to enable dispatch of responders to provide assistance to those in need. Further discussions on accuracy are beyond the scope of the present document.

The location value describes where the caller is as a consequence of this a location value needs to be considered private and only made available to authorized entities.

4.2.3 Location identifier

A location identifier is a datum that is public or semi-public and is used to derive a serving area where the UE is present or the position of a network termination point to which the UE is attached. The area and prescribed identifier may be associated with the physical access network, such as a mobile Cell-ID, WiFi AP or line identifier. However, the location identifier does not have to be tied to an access network termination point, provided that the defined area includes the termination point to which the UE is attached.

A location value derived from a location identifier can be accurate enough to allow routing to occur to the correct PSAP but is often not good enough to allow accurate dispatch or emergency responders to provide assistance to those in need. Further discussions on accuracy are beyond the scope of the present document.

Since a location identifier can be translated into a physical area in which a caller is likely to be they should be used with care to ensure that the physical location of the caller is not inadvertently provided to an unauthorized entity.

4.2.4 Location reference

A location reference is a key, often a URI, which identifies a location server and provides sufficient information to allow the location server to provide the location value of the UE. The location reference does not explicitly represent a physical location, the location is returned when the reference is used allowing a location reference to be accessed multiple times resulting in location updates being provided. This is not possible with a location value or location identifier.

Unlike a location value or location identifier, a location reference does not in and of itself contain the location of the caller. This attribute allows a location reference to be used in a range of network environments as long as suitable authentication and authorization policies are implemented on the location server.

5 Functional architecture to support European requirements on emergency caller location determination and transport

5.1 Overview

The functional architecture to support EC requirements on emergency caller location determination and transport identifies four service provider roles as represented in figure 5.1:

- Access network provider (ANP);
- Voice service provider (VSP);
- Emergency call service provider (ECSP); and
- PSAP service provider (PSP).

The ANP, ECSP and PSP are in the same regulatory domain. The VSP can be inside or outside this domain.

NOTE: On the basis of the European Regulatory Framework the emergency services provision inside a country is in charge of its administration; so the term "regulatory domain" typically coincides with a single country. In some cases a specific agreement can be defined between neighbouring countries to correctly manage the provision of the emergency services, for example in areas close to the common border.

This architecture is neutral regarding deployment and business models. It defines the functional roles of different network segments. Multiple roles can be played by a single actor or by multiple actors, each actor managing its own resources to fulfil a role.

Clause 5.2 specifies the functional requirements to be fulfilled by a service provider when playing these roles.

Clause 5.3 specifies the interfaces used to support communication between these roles and interfaces with user equipment and PSAPs.

For each interface the functional description is provided in clause 5.3.1, while clause 5.3.2 provides, without going into the details of the protocols, the description of the information flows that the functional entities need to exchange to implement the service.

The communication is specified with reference to the functional entities, defined in clause 5.4, that each role needs to implement and are explicitly evidenced in figure 5.1.

Clause 5.5 finally provides the information flow diagrams needed to implement the service in different conditions, with reference to the information elements defined in clause 5.3 and without addressing protocol aspects.

The architecture covers two methods for transmission of location values to the PSAPs, the push and the pull method:

- In the push method the location values are transmitted via the ii or ij interface as part of the call setup signalling information or via the ik or im interface directly to the PSAP as soon as the emergency call request is sent to the PSAP.
- In the pull method the PSAP receives via the ii or ij interface the information required to acquire a location value from the LS or the LS Proxy via the ik, il or im interface. The request is triggered manually by the PSAP operator on a case by case basis or automatically in the PSAP entity with every emergency call request received.

The method, or combination of methods, for getting a location value from the ECSP to a PSAP is decided via prior agreement between the ECSP and the PSAP authority.

As a general remark, if an interface is internal to an operator (e.g. the "in" interface as presently depicted in figure 5.1), its functional description does not mandate the implementation of the corresponding protocols, provided this does not impact on the functionality of the external interfaces.

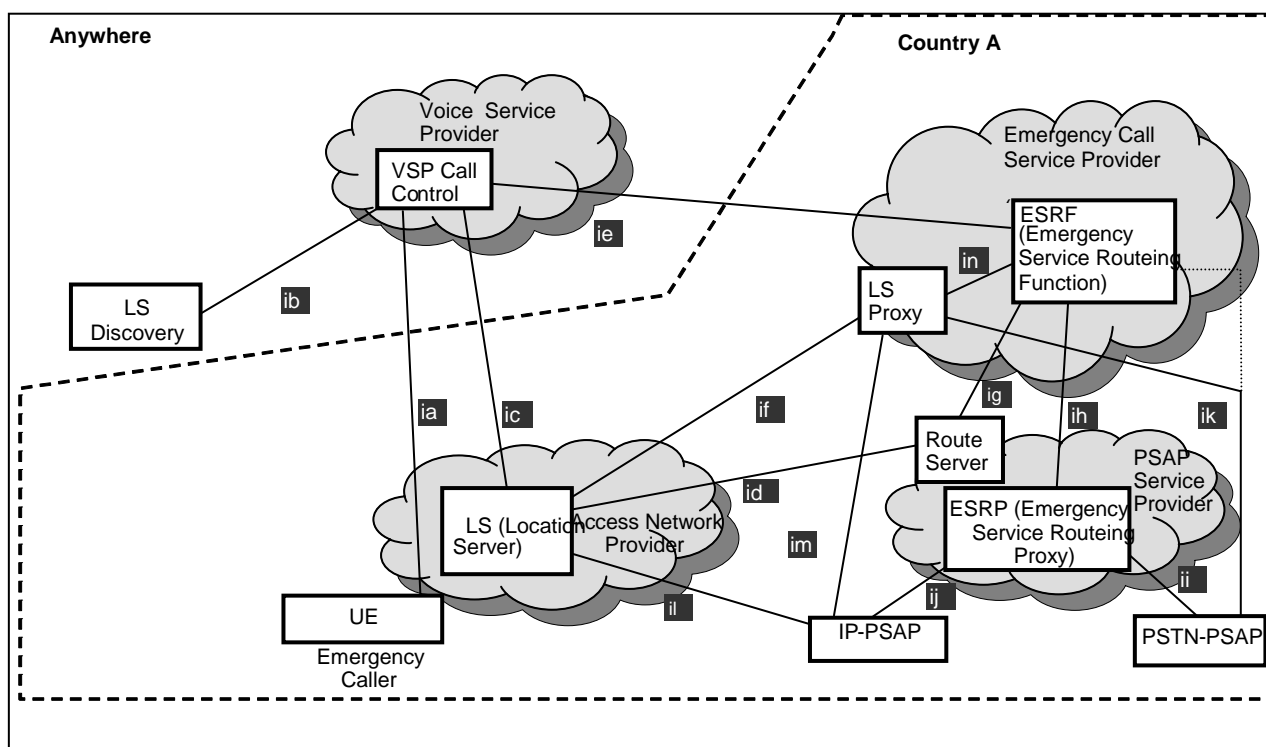

Figure 5.1: High level Functional Architecture

5.2 Architectural requirements

5.2.1 General

The following technical requirements describe the set of actions performed by the different roles that can be involved in the provision of an emergency service. It is the responsibility of national Administrations and Governments to decide on national implementations for emergency services. Specific attention ought to be paid to the roles that have access to sensitive end user information like caller identity and caller location.

5.2.2 ANP - Access Network Provider

The ANP:

- ANP-R1) shall provide IP-based connectivity for the UE to the VSP so that an emergency call can be made;
- ANP-R2) shall provide location information to the VSP;
- ANP-R3) shall provide routing information to the VSP when routing information is requested, so that an emergency call can be delivered to the ECSP;
- ANP-R4) shall provide (push or pull) the UE location information to the ECSP;
- ANP-R5) shall provide (push or pull) the current UE location information to the PSAP or LS proxy; and
- ANP-R6) shall provide information to location server discovery functions such that the ANP can be contacted using that information.

NOTE: The management of location information requests to an ANP's LS by VSPs presents challenges to an ANP as there are many VSPs that may make such requests and the ANP needs to protect itself against any suspicious requests. A method to manage this without requiring VSP authentication is outlined in annex D.

5.2.3 VSP - Voice Service Provider

The VSP:

- VSP-R1) shall determine that the call is to be classified as an emergency call and, if applicable, its emergency category;
- VSP-R2) shall obtain the identity of the ECSP, in the same regulatory domain as the UE, to handle the call from the UE;
- VSP-R3) shall direct the call to the identified ECSP;
- VSP-R4) shall obtain the caller location information provided by the ANP;
- VSP-R5) shall convey the caller location information to the ECSP; and
- VSP-R6) should convey information provided by the UE to the ECSP.

5.2.4 ECSP - Emergency Call Service Provider

The ECSP:

- ECSP-R1) shall be capable of receiving emergency calls from a trusted sender (e.g. a VSP or VAP);

NOTE 1: The VAP is defined in annex C.

- ECSP-R2) shall obtain location information from the Access Network Provider if location information is not included in the emergency call request received from the VSP or VAP or additional location information is required to select the appropriate destination;
- ECSP-R3) shall provide interconnection with IP-based PSPs;
- ECSP-R4) shall provide call interworking with existing PSP implementations;
- ECSP-R5) shall determine the correct PSAP address to which to direct the emergency call;

NOTE 2: The PSAP address determined by the ECSP may identify a PSAP or a group of PSAPs.

NOTE 3: Determination of the PSAP address is based on location and type of emergency, and not on busy/free status of the individual PSAP identified by the PSAP address.

- ECSP-R6) shall direct the emergency call towards the selected PSAP address;

- ECSP-R7) shall convey the caller location information to the PSAP Service Provider network; and
- ECSP-R8) should convey information provided by the UE via the VSP and VAP to the PSAP Service Provider network.

NOTE 4: Conveyance of information provided in the user plane may not always be possible (e.g. conveyance of non-voice band data to a circuit-switched PSP network).

5.2.5 PSP - PSAP Service Provider

The PSP:

- PSP-R1) shall accept emergency calls from Emergency Call Service Providers;
- PSP-R2) shall acquire all information not provided in the call signalling that is necessary for the selection of the correct PSAP to which to direct the emergency call;

NOTE 1: In some cases the PSP will have been provided all information necessary in order to direct the call to the PSAP, for example a destination node E.164 number or a location value in the body of a SIP message. In other cases the PSP will need to acquire information from external sources before it has sufficient information to determine the correct PSAP, for example if a location value is required to determine the correct PSAP and the PSP only has a location URI then the PSP acquires the location value using the location URI prior to the PSAP selection taking place.

- PSP-R3) shall, if the call destination provided by the ECSP does not uniquely identify a PSAP, determine the correct PSAP identifier to which to direct the emergency call;

- PSP-R4) shall determine a network access where the identified PSAP is connected;

NOTE 2: In the most simple case the PSP is provided the identity of the desired PSAP by the ECSP. However, PSAP selection inside the PSP may employ more complex policies for destination selection. Such policies may be used to avoid congestion or to ensure that the provisions of the emergency caller are better accommodated. These provisions may include the need for language translation services or indicate some kind of disability such as hearing or speech.

- PSP-R5) shall route the emergency call to the selected network access (determined according to R4); and

- PSP-R6) shall provide all available call information with the call to the PSAP subject to the networks ability to convey this information.

NOTE 3: This architecture assumes that the PSAP service provider is responsible for originating services from the PSAP (including callback requests) and both originating and terminating services (e.g. transfer to another answer point) for the PSAP. These capabilities are outside the scope of the present document, unless the PSAP service provider needs to retain information from the original emergency call to perform these functions. The ECSP has no responsibility for these additional functions.

5.3 Interfaces

5.3.1 Interface definitions

The functional architecture includes interfaces for interactions between different functional network components related to emergency caller location determination and transport. In case of discrepancy with clause 5.3.2, the later takes precedence.

ia:

Interface between the user equipment and the VSP call control.

Communication provides sufficient information to the VSP, to indicate that the user equipment is making an emergency call, and conveys sufficient information to enable the VSP call control to invoke location server discovery.

ib:

Interface between the VSP call control and the location server discovery functional entity.

The VSP call control provides sufficient information to allow the location server discovery functional element to provide either the ANP domain name or the URI of the location server serving this domain.

ic:

Interface between the VSP call control and the location server.

The VSP call control includes sufficient information to allow the location server to identify the user equipment in the access network. The location server returns location information and may return the address of the ESRF assigned to service the call. The ESRF address shall be returned by the location server when the VSP requests routing information.

id:

Interface between the location server and the route server.

The location server provides a location value to the route server and the route server responds with the address of the ESRF associated with the proffered location.

The location server's primary function is to determine the location of devices attached to the access network and make appropriate information available to functional entities involved in the emergency call. To determine the ECSP and ESRF responsible for serving an emergency call made at a certain location is the responsibility of the route server. In order for the LS to provide ECSP address information the LS acquires it from the route server. This can be done at provisioning time or in real-time depending on implementations.

The location server may be provisioned with the address of the route server or it may discover the address of the route server using mechanisms such as those described in IETF RFC 5222 [i.10].

NOTE: This interface is used when an ESRF URI is requested by the VSP and no such URI is configured on the LS.

ie:

Interface between the VSP call control and the serving ESRF in the ECSP network.

The VSP call control adds the location information and directs the call to the ESRF address.

if:

Interface between the LS Proxy and the location server.

The ESRF or PSAP uses the location reference or location identifier to acquire the user equipment location value from the location server via the LS Proxy.

ig:

Interface between the serving ESRF and the route server.

The ESRF provides a location value to the route server. The route server responds with the address of the ESRP in the PSP network or the destination PSAP address.

ih:

Interface between the serving ESRF in the ECSP network and the ESRP in the PSP network.

The serving ESRF in the ECSP network includes with the call, location information (reference identifier and/or a location value) in the signalling to the ESRF in the PSP network.

ii:

Interface between the ESRP in the PSP network and a PSTN-based PSAP.

The ESRP provides sufficient information with the call to allow the PSTN-based PSAP to identify the serving ESRF and the call in progress through that ESRF in the ECSP network. Information transported across this interface is limited by the capabilities of the legacy PSTN protocol. If the protocols do not support transport of location information, the location information can be retrieved through ik.

ij:

Interface between the ESRP in the PSP network and an IP-based PSAP.

The ESRP provides with the call, location information (reference and/or location value).

ik:

Interface between the PSTN-based PSAP and the LS Proxy or the ESRF.

il:

Interface between the IP-based PSAP and the location server.

The IP-based PSAP uses the location reference to request information from the location server. The location server responds with the current location of the caller in the form of a location value.

im:

Interface between the IP-based PSAP and the LS Proxy.

The IP-based PSAP uses the location reference to request information from the location server.

in:

Interface between the ESRF and the LS Proxy in the ECSP.

The ESRF sends a location request to acquire the caller's location. The ESRF receives one or more location values from the LS proxy. In addition the in interface can be used to exchange call context data.

5.3.2 Information flows

The following tables describe the information flows by listing the information elements which are exchanged via the individual interfaces of the functional architecture. In the column "Status" the abbreviations have the following meaning:

M:	Mandatory
O:	Optional
C:	Conditional
N/A:	Not Applicable or Not Relevant

5.3.2.1 ia interface

Table 5.1 describes the information flow from the UE to the VSP via the ia interface.

Table 5.1: Call Request (UE to VSP call control)

Information Element	Status	Description
Called identity	M	Emergency service indicator as provided by the user
User-provided caller identity	O	Caller's VoIP identity provided by the end user
User-provided location information	O	location information as provided by the user equipment (see note 1)
IP address and port	M	Caller's public IP address and source port number (see note 2)
Other information	N/A	Outside the scope of the present document
NOTE 1: This element may appear multiple times.		
NOTE 2: May come from the IP header or from the Via header field when SIP is used.		

5.3.2.2 ib interface

The LS Discovery Request information flow is used by a VSP Call Control entity to retrieve the URI of the location server in the access network serving the user equipment or the ANP domain name. Table 5.2 describes the information flow from the VSP Call Control to LS Discovery via the ib interface.

Table 5.2: LS Discovery Request (VSP Call Control to LS Discovery)

Information Element	Status	Description
Calling IP address	M	IP address of the calling user equipment as perceived by the VSP

The LS Discovery Response information flow is used by a LS Discovery to respond to a request from a VSP Call Control entity. Table 5.3 describes the information flow from the LS Discovery to VSP call control via the ib interface.

Table 5.3: LS Discovery Response (LS Discovery to VSP call control)

Information Element	Status	Description
Location Server URI	C	URI of the Location Server within the ANP providing IP-based connectivity to the VSP and serving the UE (see note)
ANP domain name	C	The domain name of the ANP providing IP-based connectivity to the VSP and serving the UE (see note)
NOTE: At least one of the information elements needs to be sent.		

This interface may be affected by network elements that are altering the packet flow identity information. Refer to clause 5.6 for further considerations.

5.3.2.3 ic interface

The Location Request information flow is used by a VSP Call Control entity to retrieve location information from a Location Server in an ANP domain. Table 5.4 describes the information flow from the VSP Call Control to Location Server via the ic interface.

Table 5.4: Location Request (VSP Call Control to Location Server)

Information Element	Status	Description
Calling IP address and port	M	IP address and source port number of the calling user equipment as perceived by the VSP
Location identifier	O	Location identifier as determined by the VSP (see note)
Routeing request	O	Indicator to the LS that it needs to provide an ESRF URI in the location response
NOTE: May be retrieved from a database in the ANP.		

The Location Response information flow is used by a Location Server in an ANP domain to respond to a Location Request from a VSP Call Control entity. Table 5.5 describes the information flow from the Location Server to VSP call control via the ic interface.

Table 5.5: Location Response (Location Server to VSP call control)

Information Element	Status	Description
Network-provided location information	M	Caller's location as determined by the ANP (see note)
ESRF URI	C	The LS shall provide an ESRF URI if the location request includes a routeing request and may provide an ESRF URI if the location request does not include a routeing request. The ESRF URI represents the address to which the VSP needs to direct the emergency call
NOTE: This information element may be repeated several times.		

This interface may be affected by network elements that are altering the packet flow identity information. Refer to clause 5.6 for further considerations.

5.3.2.4 id interface

Table 5.6 describes the request information flow from the LS to the Route Server via the id interface.

Table 5.6: Routeing Information Request (Location Server to Route Server)

Information Element	Status	Description
Location value	M	Caller's location as determined by the ANP

Table 5.7 describes the response information flow from the Route Server to the LS via the id interface.

Table 5.7: Routeing Response (Route Server to Location Server)

Information Element	Status	Description
ESRF URI	M	The ESRF URI represents the address to which the VSP needs to direct the emergency call

5.3.2.5 ie interface

Table 5.8 describes the information flow from the VSP call control to ESRF via the ie interface. An additional usage of this interface is described in annex C.

Table 5.8: Call Request (VSP call control to ESRF)

Information Element	Status	Description
Called Identity	M	Emergency service indicator, as provided by the user or set by the VSP based on user provided input
Network-provided caller identity	M	Caller's VoIP identity asserted by the VSP
Network-provided location information	M	Caller's location as obtained by the VSP (see note 1)
VSP identity	M	The identity of the originating VSP (see note 3)
User-provided caller identity	O	Caller's VoIP identity provided by the end user
User-provided location information	O	Caller's location as determined by the user equipment (see note 1)
IP address and port	O	Caller's public IP address and source port number as perceived by the VSP (see note 2)
Other information	N/A	Outside the scope of the present document
NOTE 1: This information element may appear multiple times.		
NOTE 2: May be available in the Via header field when SIP is used.		
NOTE 3: May be ignored by the ESRF if national regulation does not require it, or if the identity can be inferred from the Network-provided caller identity.		

5.3.2.6 if interface

The Location Request information flow is used by a Location Server Proxy in an ECSP domain to request location information from a Location Server in the ANP domain. Table 5.9 describes the information flow from LS Proxy to Location Server via the if interface.

Table 5.9: Location Request (LS Proxy to Location Server)

Information Element	Status	Description
Calling IP address and port	O	IP address and source port number of the calling user equipment as received from the VSP (see notes 1 and 2)
Location reference	C (see note 3)	Location reference as received from the VSP (see note 2)
Location identifier	C (see note 3)	Location identifier as received from the VSP (see note 2)
NOTE 1: May be available in the Via header field when SIP is used.		
NOTE 2: At least one of these information elements shall be included.		
NOTE 3: Mandatory if received from the VSP.		

The Location Response information flow is used by a Location Server in the ANP domain to respond to a Location Request from a Location Server proxy in an ECSP domain. Table 5.10 describes the information flow from the Location Server to the LS Proxy via the if interface.

Table 5.10: Location Response (Location Server to LS Proxy)

Information Element	Status	Description
Location value	M	Caller's location as determined by the ANP

5.3.2.7 ig interface

Table 5.11 describes the request information flow from the ESRF to the Route Server via the ig interface.

Table 5.11: Routing Information Request (ESRF to Route Server)

Information Element	Status	Description
Location value	M	Caller's location as determined by the ANP

Table 5.12 describes the response information flow from the Route Server to the ESRF via the ig interface.

Table 5.12: Routing Response (Route Server to ESRF)

Information Element	Status	Description
Destination URI	M	The destination URI represents the address to which the ESRF needs to direct the emergency call
Location Push Destination	O	The URI or FQDN of where the location value is to be pushed (see note)
NOTE: If the push method for location value as described in clause 5.1 is to be used over ik then this element is included. If the protocol used to push location value to the PSAP has a URI scheme then this value should be a URI, otherwise it may be an FQDN.		

5.3.2.8 ih interface

The Call Request information flow is used by the ESRF in the ECSP's domain to direct a call to an ESRP in a PSP's domain.

Table 5.13 provides the list of information elements applicable to an IP-based ih interface.

Table 5.13: Call Request (ESRF to ESRP, IP-based)

Information Element	Status	Description
Called identity	M	PSAP address as determined by the ESRF
Network-provided caller identity	M	Caller's VoIP identity asserted by the VSP (see note 2)
Network-provided location information	M	Caller's location information (see note 1)
User-provided caller identity	O	Caller's VoIP identity provided by the end user
User-provided location information	O	Caller's location information as provided by the user equipment (see note 1)
IP address and port	O	Caller's public IP address and source port number as received by the ECSP
Other information	N/A	Outside the scope of the present document
VSP identity	C	The identity of the VSP through which the emergency call originated (see note 3)
NOTE 1: This element may appear multiple times.		
NOTE 2: If no network provided caller identity is available from the VSP, a locally generated value may be used.		
NOTE 3: May not be passed by the ESRF if national regulation does not require it, or if the identity can be inferred from the Network-provided caller identity.		

Table 5.14 provides the list of information elements applicable to a PSTN-based ih interface.

Table 5.14: Call Request (ESRF to ESRP, PSTN-based)

Information Element	Status	Description
Called identity	M	PSAP address as determined by the ESRF
Network-provided caller identity	M	Caller's VoIP identity asserted by the VSP or locally generated (see notes 2 and 4)
Network-provided location information	C	Caller's location information (see notes 1 and 3)
User-provided caller identity	O	Caller's VoIP identity provided by the end user
User-provided location information	O	Caller's location information as provided by the user equipment (see note 1)
Push correlation identifier	C	Identifier enabling correlation with a push notification procedure, when the push mode is used on the ik interface and the caller's identity is not available or not used for that purpose
Other information	N/A	Outside the scope of the present document
VSP identity	C	The identity of the VSP as communicated by the ECSP (see note 5)
NOTE 1: This information element may appear multiple times.		
NOTE 2: If the caller identity received by the VSP cannot be represented as a telephone number, a locally generated value that maps to the received value may be used.		
NOTE 3: If the network-provided caller identity does not serve as a location reference, at least a location reference shall be provided.		
NOTE 4: If no network provided caller identity is available from the VSP, a locally generated value may be used.		
NOTE 5: May not be passed by the ESRF if national regulation does not require it, or if the identity can be inferred from the Network-provided caller identity.		

NOTE: In some cases, the ESRF and the ESRP will not support the same call signalling protocol and/or the same transport technology. Intermediate entities within the ECSP and/or PSP domains can be inserted along the call path to perform signalling protocol and/or media transport interworking. When the PSP is PSTN-based and the ESRF does not support the PSTN technology, table 5.13 applies to the interface between the ESRF and the interworking point while table 5.14 applies to the interface between the interworking point and the ESRP.

5.3.2.9 ii interface

The Call Request information flow is used by the ESRP in a circuit-switched PSP domain to forward an incoming call to a PSTN- PSAP.

NOTE: There might be zero, one or more exchanges within the PSP domain between the ESRP and the PSTN-PSAP.

Table 5.15 describes the information flow from ESRP to PSTN-PSAP via the ii interface.

Table 5.15: Call Request (ESRP to PSTN-PSAP)

Information Element	Status	Description
Called identity	M	PSAP address as determined by the PSP
Network-provided caller identity	M	Caller's VoIP identity as received from the ECSP
Network-provided location information	O	Caller's location as received from the ECSP (see note 1)
User-provided caller identity	O	Caller's VoIP identity provided by the end user
User-provided location information	O	Caller's location as determined by the user equipment (see note 1)
Push correlation identifier	O	Identifier enabling correlation with a push notification procedure, when the push mode is used on the ik interface and the caller's identity is not available or not used for that purpose
Other information (from the network or the user)	N/A	Outside the scope of the present document
VSP identity	C	The identity of the VSP as communicated by the ECSP (see note 2)
NOTE 1: This information element may appear multiple times.		
NOTE 2: Is conveyed if received and the signalling interface is capable of doing so.		

5.3.2.10 ij interface

The Call Request information flow is used by the ESRP in an IP-based PSP domain to forward an incoming call to an IP-PSAP.

NOTE: There might be zero, one or more intermediate servers within the PSP domain between the ESRP and the IP-PSAP.

Table 5.16 describes the information flow from ESRP to IP-PSAP via the ij interface.

Table 5.16: Call Request (ESRP to IP-PSAP)

Information Element	Status	Description
Called identity	M	PSAP address as determined by the PSP
Network-provided caller identity	M	Caller's VoIP identity as received from the ECSP
Network-provided location information	M	Caller's location as received from the ECSP (see note 1)
User-provided caller identity	O	Caller's VoIP identity provided by the end user
User-provided location information	O	Caller's location as determined by the user equipment (see note 1)
IP address and port	O	Caller's public IP address and source port number (see note 2)
Other information (from the network or the user)	N/A	Outside the scope of the present document
VSP identity	C	The identity of the VSP through which the emergency call originated (see note 3)
NOTE 1: This information element may appear multiple times.		
NOTE 2: May be available in the Via header field when SIP is used.		
NOTE 3: Is conveyed if received and the protocol is capable of supporting the information element.		

5.3.2.11 ik interface

The Location Request information flow is used by a PSTN-PSAP to request location information from a Location Server Proxy or ESRF in an ECSP domain. Table 5.17 describes the information flow from PSTN-PSAP to LS Proxy or ESRF via the ik interface.

Table 5.17: Location Request (PSTN-PSAP to LS Proxy or ESRF)

Information Element	Status	Description
Network-provided caller identity	O	Caller's VoIP identity as received from the PSP (see note)
Location reference	O	Location reference as received from the PSP or created from the network provided caller's identity (see note)
Location identifier	O	Location identifier as received from the PSP (see note)
NOTE: At least one of these information elements shall be present.		

The Location Response information flow is used by a Location Server Proxy or ESRF in an ECSP domain to respond to a Location Request from a PSTN-PSAP. Table 5.18 describes the information flow from LS Proxy or ESRF to PSTN-PSAP via the ik interface.

Table 5.18: Location Response (LS Proxy or ESRF to PSTN-PSAP)

Information Element	Status	Description
Location value	M	Caller's location

The Location Push Information flow is used by an ESRF in an ECSP domain to push location information to a PSTN-PSAP. Table 5.19 describes the information flow from ESRF to PSTN-PSAP via the ik interface in case location value is pushed to the PSAP.

Table 5.19: Location Push Notification (ESRF to PSTN-PSAP)

Information Element	Status	Description
Network-provided caller identity	O	Caller's VoIP identity asserted by the VSP (see note)
Push correlation identifier	O	Identifier enabling correlation with the emergency call in case the caller's identity is not available or not used for that purpose (see note)
Location value	M	Caller's location
NOTE: At least one of these information elements shall be present.		

5.3.2.12 il interface

The Location Request information flow is used by an IP-PSAP to request location information from a Location Server in an ANP domain, table 5.20 describes the information flow from IP-PSAP to Location Server via the il interface.

Table 5.20: Location Request (IP-PSAP to Location Server)

Information Element	Status	Description
Location reference	O	Location reference as received from the VSP (see note)
Location identifier	O	Location identifier as received from the VSP (see note)
NOTE: At least one of these information elements shall be included. If neither of them is available, the im interface shall be used.		

The Location Response information flow is used by a Location Server in the ANP domain to respond to a Location Request from an IP-PSAP. Table 5.21 describes the information flow from Location Server to IP-PSAP via the il interface.

Table 5.21: Location Response (Location Server to IP-PSAP)

Information Element	Status	Description
Location value	M	Caller's location

5.3.2.13 im interface

The Location Request information flow is used by an IP-PSAP to request location information from a Location Server Proxy in an ECSP domain. Table 5.22 describes the information flow from IP-PSAP to LS Proxy via the im interface.

Table 5.22: Location Request (IP-PSAP to LS Proxy)

Information Element	Status	Description
Network-provided caller identity	O	Caller's VoIP identity as received from the PSP (see note)
Location reference	O	Location reference as received from the PSP or created from the network provided caller's identity (see note)
Location identifier	O	Location identifier as received from the PSP (see note)
NOTE: At least one of these information element shall be present.		

The Location Response information flow is used by a Location Server Proxy in an ECSP domain to respond to a Location Request from an IP-PSAP. Table 5.23 describes the information flow from LS Proxy to IP-PSAP via the im interface.

Table 5.23: Location Response (LS Proxy to IP-PSAP)

Information Element	Status	Description
Location value	M	Caller's location

The Location Push Information flow is used by a Location Server Proxy in an ECSP domain to push location information to an IP-PSAP. Table 5.24 describes the information flow from LS Proxy to IP-PSAP via the im interface in case location value is pushed to the PSAP.

Table 5.24: Location Push Notification (LS Proxy to IP-PSAP)

Information Element	Status	Description
Network-provided caller identity	O	Caller's VoIP identity asserted by the VSP (see note)
Push correlation identifier	O	Identifier enabling correlation with the emergency call in case the caller's identity is not available or not used for that purpose. (see note)
Location value	M	Caller's location
NOTE: At least one of these information elements shall be present.		

5.3.2.14 in interface

The Create Context Request information flow is used by an ESRF to stored call-related context data in an LS Proxy within the ECSP domain, it is only required where the LS Proxy is required to store call-state. Table 5.25 describes the information flow from the ESRF to the LS Proxy via the in interface.

Table 5.25: Create Context Request (ESRF to LS Proxy)

Information Element	Status	Description
Network-provided caller identity	M	Caller's VoIP identity asserted by the VSP
Location information	M	Location information as received from the VSP (see note 1)
Location reference request	C	Request the LS Proxy to generate a temporary location reference (see note 2)
NOTE 1: This information element may be repeated several times.		
NOTE 2: This information element shall be included if the network-provided caller identity cannot be conveyed in PSTN signalling or does not uniquely identifies a calling user.		

The Create Context Response information flow is used by an LS Proxy to respond to a Create Context Request from an ESRF. Table 5.26 describes the information flow from the LS Proxy to the ESRF via the in interface.

Table 5.26: Create Context Response (LS Proxy to ESRF)

Information Element	Status	Description
Location reference	C	Locally-generated location reference (see note)
NOTE: This information element shall be included if the location reference request was included in the request.		

The Delete Context Request information flow is used by an ESRF to remove call-related context data in an LS Proxy within the ECSP domain. Table 5.27 describes the information flow from the ESRF to the LS Proxy via the in interface.

Table 5.27: Delete Context Request (ESRF to LS Proxy)

Information Element	Status	Description
Network-provided caller Identity	O	Caller's VoIP identity asserted by the VSP (see note)
Location reference	O	Locally-generated location reference (see note)
NOTE: At least one of these information elements shall be included.		

The Location Request information flow is used by an ESRF to request location information from a Location Server Proxy in an ECSP domain. Table 5.28 describes the information flow from ESRF to LS Proxy via the in interface.

Table 5.28: Location Request (ESRF to LS Proxy)

Information Element	Status	Description
Location reference	O	Location reference as received from the VSP or the LS proxy or created from the network provided caller's identity (see note)
Location identifier	O	Location identifier as received from the VSP (see note)
NOTE: At least one of these information element shall be present.		

The Location Response information flow is used by a Location Server Proxy in an ECSP domain to respond to a Location Request from an ESRF. Table 5.29 describes the information flow from LS Proxy to ESRF via the in interface.

Table 5.29: Location Response (LS Proxy to ESRF)

Information Element	Status	Description
Location value	M	Caller's location

5.4 Functional entities

5.4.1 ANP

NOTE: The ANP is in charge of authenticating the end user for IP connectivity provision and it may not have knowledge of the kind of IP traffic exchanged or whether such a traffic is associated with a telephone call (an emergency call is a particular type of telephone call).

5.4.1.1 Location Server (LS)

The LS provides functionalities which shall be used to retrieve location information and optionally IP routing information. Upon the receipt of a location information request via interface ic the LS:

- 1) shall only return a location value if the requesting entity is authenticated and authorized to obtain a location value;
- 2) shall only return a location identifier if the requesting entity is authenticated and authorized to obtain a location identifier;
- 3) may require authentication and authorization of the requesting entity before returning a location reference;

NOTE: Authentication of the requesting entity may be explicit or implicit depending on network configuration and operator agreements.

- 4) should only transfer data using a secure communications channel;
- 5) if not locally available, shall retrieve from other entities in the ANP's domain the location information of the physical access belonging to the calling user; and
- 6) shall provide the appropriate location information to the requesting entity depending on the level of trust between the requesting entity and the ANP.

If the location information request comes from a VSP call control and includes a routeing request, the LS shall:

- 7) if an ESRF URI is not locally configured for the concerned location, retrieve routeing information from a route server; and
- 8) provide the relevant ESRF URI to the VSP call control.

5.4.2 VSP

5.4.2.1 VSP Call Control

The VSP provides a call control function that is the first point of contact for call signalling coming from the UE.

The VSP call control supports interfaces with the UE (ia), the ANP (ic), the ECSP (ie) and the LS Discovery function (ib). These interfaces can be intra-operator or inter-operator interfaces.

The VSP call control provides the following functionality which identifies calls intended to be emergency calls. Upon recognition of an emergency call from the UE the VSP call control:

- 1) shall determine the public IP-address (and port) of the UE;

NOTE 1: This functionality may be affected by network elements that are altering the packet flow identity information. Refer to clause 5.6 for further considerations.

- 2) shall acquire from the LS discovery function the ANP domain name or the LS URI. If an ANP domain name is received from the LS discovery function, the VSP call control shall query the DNS to obtain the LS URI using the ANP domain name as input to a URI-enabled NAPTR (U-NAPTR) resolution process [i.1.1];
- 3) shall retrieve ESRF IP routeing information and UE's network-provided location information from the LS when the UE's public IP address and the route to the LS are available, and location information is not already available;

NOTE 2: Under specific circumstances, location information can already be available e.g. in case the role of the VSP and the ANP are played by the same actor and this information is pushed from the ANP upon network attachment.

- 4) shall include the information provided by the LS in the call setup message towards the ESRF;
- 5) shall check the validity of the caller's identity information (e.g. tel URI) if provided by the UE and shall provide this information in the call setup message;
- 6) shall pass any emergency category (e.g. fire, ambulance, police, mountain rescue) received from the UE to the ESRF;
- 7) should pass any user-provided location information received from the UE to the ESRF without modification; and
- 8) may generate Call Data Records.

5.4.3 ECSP

5.4.3.1 ESRF

The ESRF is a routing proxy hosting emergency-specific logic.

Upon receipt of an emergency call from a VSP or VAP, the ESRF:

- 1) shall interact with the LS Proxy or LS to obtain location information from the ANP if location information is not included in the emergency call request received from the VSP or VAP or additional location information is required to select the appropriate destination;
- 2) may query a Route Server;
- 3) shall determine the correct PSAP address to which to direct the emergency call;
- 4) shall set the network-provided caller identity to a locally generated value that maps to the received value, if no meaningful value was received from the VSP or VAP or if the call is to be routed to the PSTN and the received value cannot be conveyed using PSTN signalling protocols (e.g. SIP URI with non-numeric user part);
- 5) shall direct the emergency call towards the selected PSAP address, possibly through intermediate entities as per clause 5.4.3.3;
- 6) shall pass network-provided location information received from the VSP, LS Proxy, or LS, to the ESRP if the communication mechanism supports transport of the type of location information received;
- 7) should pass any user-provided location information received from the UE to the ESRP without modification;

NOTE: This recommendation applies whenever the protocol is capable of conveying the information provided.

- 8) may request the LS Proxy to create a call context and delete this call context once the call is completed; and
- 9) may generate Call Data Records.

5.4.3.2 LS Proxy

The LS Proxy acts as a proxy between the Location Server in the ANP domain and an ESRF in the ECSP domain or a PSAP. The LS proxy shall be able to create and delete call context data upon request from the ESRF.

Upon receipt of location request from the ESRF or a PSAP, the LS Proxy shall respond to the request with one or more location values if locally available and deemed still valid. Otherwise the LS proxy shall:

- 1) determine the identity of the LS that can serve the request;
- 2) if the request only contains a caller identity or the location reference received in the request was not generated by the LS, map this information to a location reference that can be understood by the LS;
- 3) forward the request to the LS;
- 4) store the contents of the response received from the LS and include this contents in the response to the requesting ESRF or PSAP.

NOTE: The possible presence of a LS Proxy in the Emergency Call Service Provider (ECSP) is a national matter. It is up to the ECSP to decide whether the LS Proxy is implemented as a separate entity from the ESRF instances or is collocated with each of them.

5.4.3.3 Other entities

Other entities may be involved for the purpose of routing the call and/or performing protocol interworking. Such entities are not further described in the present document as they do not provide emergency-specific functionality.

5.4.4 PSAP Service Provider

5.4.4.1 Emergency Service Routeing Proxy

The ESRP is a routeing proxy which forwards emergency calls towards their final destination.

NOTE 1: Depending on the technology used by the PSP, the ESRP can be e.g. a PSTN transit or local exchange, a SIP proxy or a SIP back-to-back user agent.

Upon the receipt of an emergency call from an ECSP, the ESRP:

- 1) shall acquire all information not provided in the call signalling that is necessary for the selection of the correct PSAP to which to direct the emergency call;
- 2) if the call destination provided by the ECSP does not uniquely identify a PSAP, shall determine the correct PSAP identifier to which to direct the emergency call;
- 3) shall forward the emergency call towards the selected PSAP;

NOTE 2: If the PSAP is not directly attached to the ESRP, the ESRP forwards the emergency call to the next hop according to regular routeing procedures in force in the PSP's network.

NOTE 3: More complex policies for destination selection can be applied, e.g. to detect the unavailability of the PSAP previously determined by the ESRP and forward the emergency call to another PSAP which is able to handle it correctly.

- 4) should perform load distribution and load control to protect the PSAPs;
- 5) should pass any user-provided location information received from the UE to the PSAP without modification; and
- 6) may generate Call Data Records.

5.4.4.2 Route Server

A route server is a functional element which maps a location value into an addressURI to route an emergency call toward the correct PSAP. This procedure is used when an ESRF URI is requested by the VSP call control and no such URI is configured on the LS or an ESRP or PSAP address is requested by the ESRF.

Upon the receipt of a location value and a routeing information request via the interfaces id or ig the route server:

- 1) shall authenticate and authorize the entity requesting routeing information;

NOTE: The authentication and the transmission security can be done by different means. Secure IP-protocols which provide state-of-the-art authentication and encryption can be used, if the location information provision is done via the Internet or by using other means selected by mutual agreement between the PSAP service provider and location information requestor. Authentication and authorization can happen before the routeing information request.

- 2) shall provide the appropriate addressrouteing information to the requesting entity. depending on the level of trust between the PSAP service provider, the ANP and the ECSP.

5.4.4.3 Other entities

Other entities may be involved for the purpose of routeing the call to the PSAP (e.g. if the PSAP is not directly attached to the ESRP) and/or performing protocol interworking (e.g. if the technology used by the PSAP is different from the technology used by the ESRP). Such entities are not further described in the present document as they do not provide emergency-specific functionality.

5.4.5 other functional entities

5.4.5.1 Location Server Discovery Function

The LS discovery function provides functionalities to retrieve the address of the correct location server within the ANP domain. The ANP is responsible for providing the necessary data.

The location server discovery function shall be supported by widely available existing methods; such methods shall not be restricted by the presence of national boundaries.

Upon the receipt of an LS discovery request from the VSP the LS discovery function:

- 1) shall determine the corresponding ANP domain based on the public IP address of the UE;

NOTE 1: This functionality may be affected by network elements that are altering the packet flow identity information. Refer to clause 5.6 for further considerations.

- 2) if it is intended to provide the address of the LS in response to the LS discovery request, shall determine the URI of the LS in the ANP domain which was identified in the first step; and

NOTE 2: For reasons of LS differentiation or prioritization this request can include an emergency call identifier.

- 3) shall provide the URI of the LS or the ANP domain name to the VSP.

5.4.5.2 User Equipment

The UE is connected directly to a public network access point or within a private network connected to a public network access point. In the context of emergency service the UE allows a user to access the emergency call service delivered by the VSP:

- 1) The UE shall be able to support a voice call.
- 2) The UE may be able to recognize the call as an emergency call.
- 3) The UE can include user provided location information in the request to establish an emergency session.
- 4) The UE shall direct the call to the VSP.

5.4.5.3 IP-PSAP

The IP-PSAP is connected to the ESRP using IP technologies. In the context of emergency calls and corresponding location information the IP-PSAP:

- 1) shall respond to emergency call setup requests;
- 2) shall receive location information linked to emergency calls via ij interface in push mode or via il or im interface in push or pull mode;
- 3) should receive user-provided caller identity, user-provided location information and caller's public IP address and port.

NOTE: Whether an IP-PSAP uses interface il to LS at ANP or interface im to the LS Proxy at the ECSP depends on implementation needs.

5.4.5.4 PSTN-PSAP

The PSTN-PSAP is connected to the ESRP using PSTN technologies (e.g. ISDN or POTS). In the context of emergency calls and corresponding location information the PSTN-PSAP:

- 1) shall respond to emergency call setup requests;
- 2) shall receive location information linked to emergency calls via ii interface in push mode or via ik interface in push or pull mode;

- 3) should receive user-provided caller identity and user-provided location information.

5.5 Information flow diagrams

5.5.1 Introduction

The following clauses provide information flow diagrams for various cases covered by the functional architecture in figure 5.1. The information flow diagrams indicate the timely sequence of the information flows exchanged as described in clause 5.4 between the functional entities for the call setup, the location determination and transport to the PSAP. The following cases are illustrated:

- 1) The ANP provides a location value to the VSP. The ECSP and PSP route the call to the PSAP, based on this location value. The location value is pushed to the PSAP. In this case the ANP has a trusted relationship to the VSP.
- 2) The ANP provides a location reference to the VSP. The ECSP pulls the location value and routes the call to the PSP. The PSP routes the call and pushes the location value to the PSAP. This is the general case, when there is no trusted relationship between ANP and VSP.
- 3) The ANP provides a location identifier to the VSP. The ECSP maps the location identifier to a location value and routes the call to the PSP. The PSP routes the call to the PSAP. The PSAP pulls a location value from the LS via LS Proxy. In this case the ANP has a trusted relationship to the VSP.
- 4) The ANP provides a location identifier to the VSP. The ECSP maps the location identifier to a location value and routes the call to the PSP. The PSP routes the call to the PSAP. The PSAP pulls the location value from the LS without using the LS Proxy. In this case the ANP has a trusted relationship to the VSP.

The flow diagrams show examples of the push and pull modes. If the protocols used on the ii or ij interface do not support the transport of location information in the available form or if the PSAP is not configured to receive location information in call setup messages, the PSAP either retrieves location information in pull mode over the ik interface or the il interface (see step 12 to 15 in figure 5.4) or the ECSP pushes location information over the ik or im interface in conjunction with the call setup request (step 11 in figure 5.2).

5.5.2 ANP provides a location value

The information flow diagram in figure 5.2 describes emergency call routing when the ANP provides location information in the form of a location value.

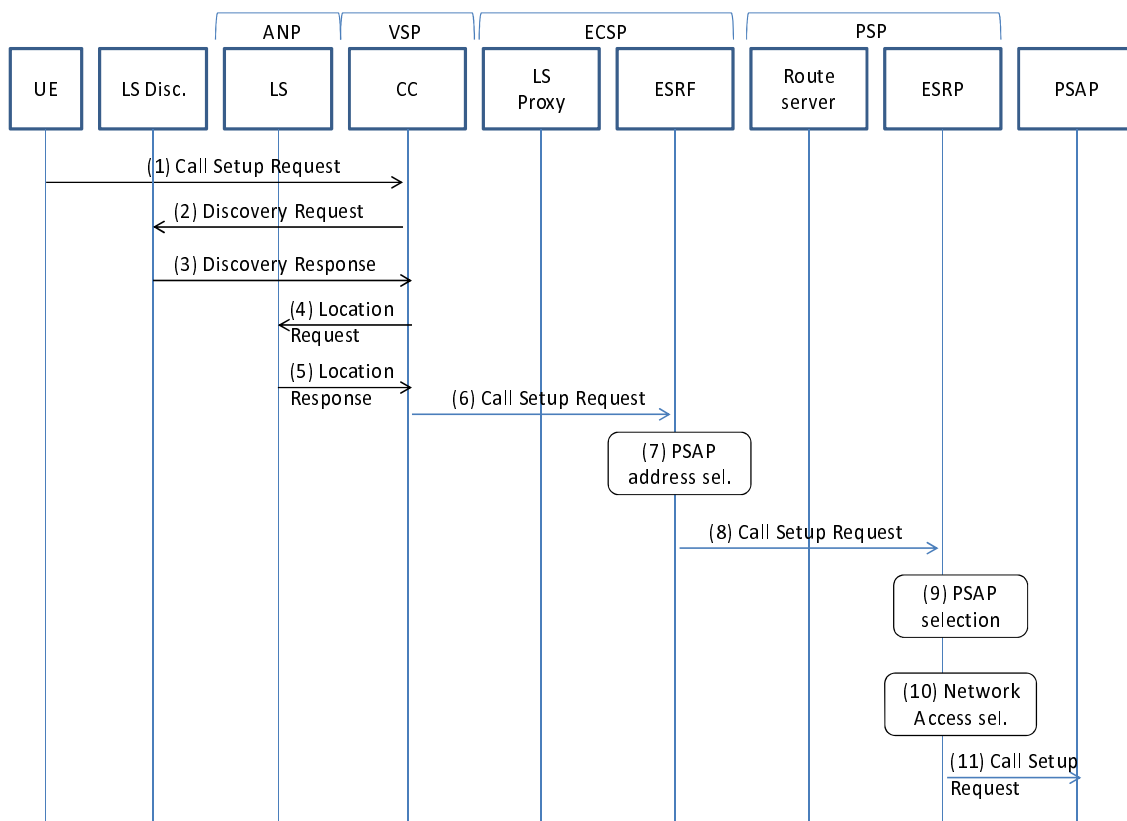

Figure 5.2: Call routing procedure when ANP provides location value

- 1) The UE sends a Call Setup Request to the VSP Call Control. The VSP Call Control recognizes it as an attempt to make an emergency call.
- 2) The VSP Call Control uses the source IP address of the Call Setup Request to query the LS Discovery functional entity.
- 3) The LS Discovery functional entity provides the LS URI or the ANP domain name that corresponds to the provided IP address.

NOTE 1: The VSP Call Control may have this information in a local cache, in which case Step 2 and 3 are not executed.

- 4) The VSP Call Control uses the source IP address and port of the Call Setup Request to query the Location Server for the caller's location.

NOTE 2: If a location identifier was obtained by other means (e.g. a cell id obtained from a PCRF in 3GPP networks), it may be used to query the location server as an alternative or in addition to the IP address and port.

- 5) The Location Server provides one or more location values (civic and/or geodetic position) and an ESRF URI if routing information was requested.
- 6) The VSP inserts the received values in the Call Setup Request and forwards to the received ESRF URI, if any, or to a URI associated to the ECSP determined by local policy.
- 7) The ESRF determines the PSAP address to which to direct the emergency call. As part of the determination the ESRF either queries a route server or uses a locally determined PSAP address using configuration information.
- 8) The ESRF forwards the Call Setup Request to the ESRP in the PSAP Service Provider's domain, via zero, one or more intermediate entities, using standard routing procedures.

- 9) If the PSAP address does not uniquely identifies a PSAP, the ESRP determines the correct PSAP identifier (e.g. by applying load balancing).
- 10) The ESRP determines the network access where the PSAP is connected.
- 11) The ESRP forwards the Call Setup Request to the identified access, via zero, one or more intermediate functional entities. Together with the Call Setup Request the ESRP pushes the location value via the ij or ii interface (depending of the access technology of the PSAP, IP or PSTN) to the PSAP.

5.5.3 ANP provides location reference to the VSP and the ECSP pulls location value

The information flow diagram in figure 5.3 describes emergency call routing and location provisioning when the ANP provides location information to the VSP only in the form of a location reference.

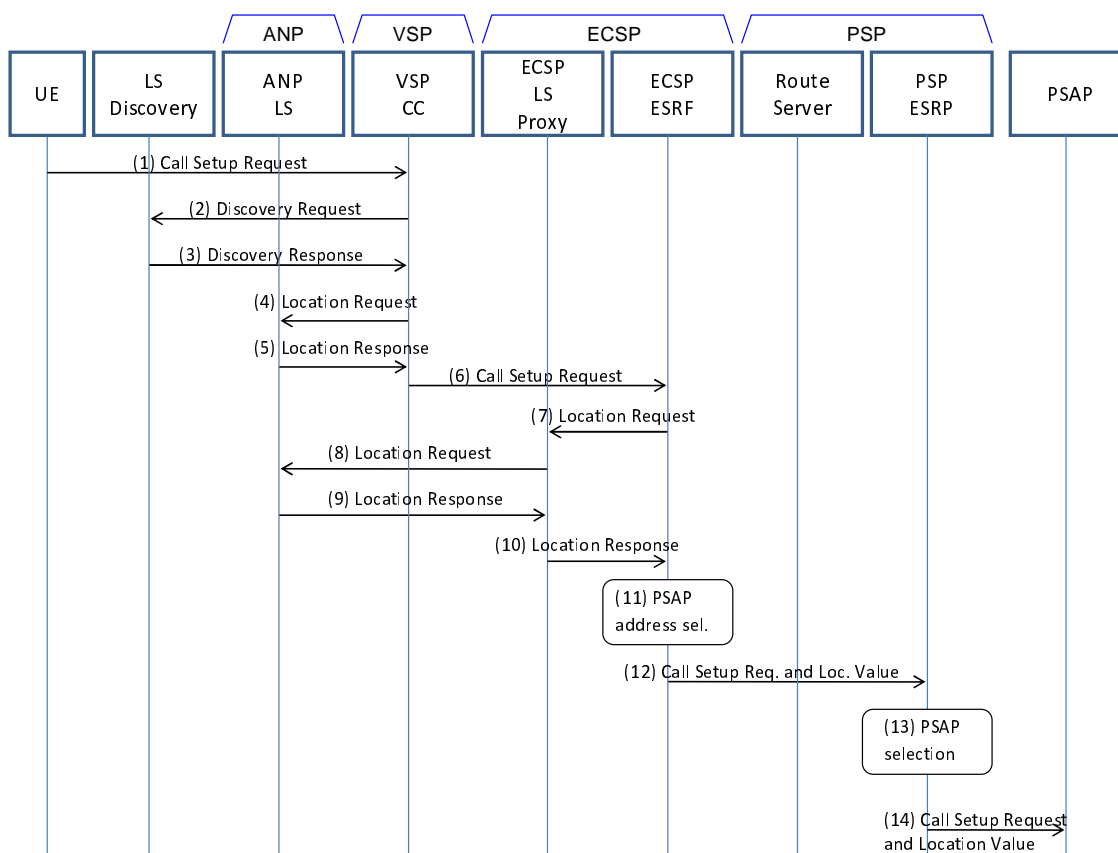

Figure 5.3: Call routing and location provisioning procedure when ANP provides location reference

- 1) The UE sends a Call Setup Request to the VSP Call Control. The VSP Call Control recognizes it as an attempt to make an emergency call.
- 2) The VSP Call Control uses the source IP address of the Call Setup Request to query the LS Discovery functional entity.
- 3) The LS Discovery functional entity provides the LS URI or the ANP domain name that corresponds to the provided IP address.

NOTE: The VSP Call Control may have this information in a local cache, in which case Step 2 and 3 are not executed.

- 4) The VSP Call Control uses the source IP address and port of the Call Setup Request to query the Location Server for the caller's location.
- 5) The Location Server provides a location reference and an ESRF URI if routing information was requested.

- 6) The VSP inserts the received location reference in the Call Setup Request and forwards to the received ESRF URI, if any, or to a URI associated to the ECSP determined by local policy.
- 7) The ESRF requests location information by sending the location reference and optionally the IP address and port of the calling user to the LS Proxy.
- 8) The LS Proxy forwards the location request by sending the received location reference and optionally the IP address and port of the calling user to the Location Server.
- 9) The Location Server responds by sending the location value to the LS Proxy.
- 10) The LS Proxy forwards the location value to the requesting ESRF.
- 11) The ESRF determines the PSAP address to which to direct the emergency call. As part of the determination the ESRF either queries a route server or uses a locally determined PSAP address using configuration information.
- 12) The ESRF forwards the Call Setup Request to the ESRP in the PSAP Service Provider's domain, via zero one or more intermediate entities, using standard routing procedures.
- 13) If the PSAP address does not uniquely identifies a PSAP, the ESRP determines the correct PSAP identifier (e.g. by applying load balancing).
- 14) The ESRP forwards the Call Setup Request to the identified PSAP via zero one or more intermediate functional entities, using standard routing procedures. Together with the Call Setup Request the ESRP pushes the location value via the ij or ii interface (depending of the access technology of the PSAP, IP or PSTN) to the PSAP.

5.5.4 ANP provides to the VSP a location identifier

The information flow diagram in figure 5.4 describes emergency call routing and location provisioning when the ANP provides location information to the VSP in the form of a location identifier and optionally a location reference.

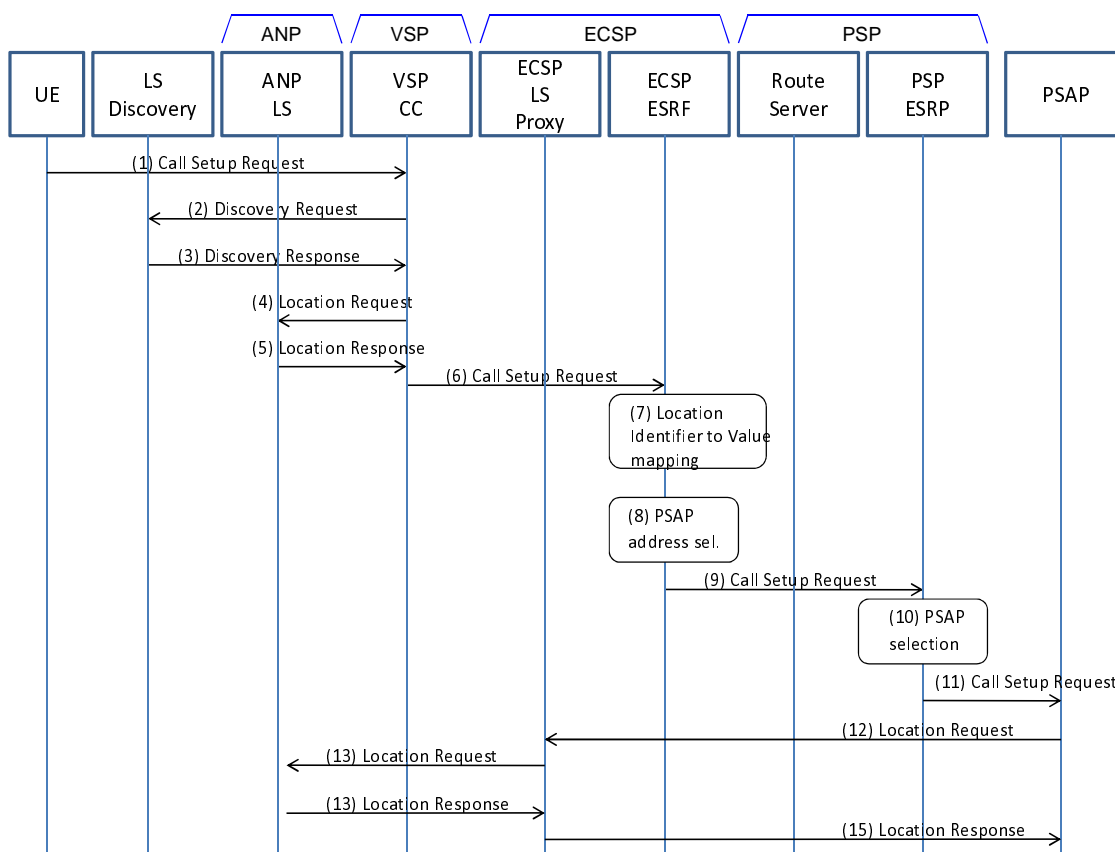

Figure 5.4: Call routing and location provisioning procedure

- 1) The UE sends a Call Setup Request to the VSP Call Control. The VSP Call Control recognizes it as an attempt to make an emergency call.
- 2) The VSP Call Control uses the source IP address of the Call Setup Request to query the LS Discovery functional entity.
- 3) The LS Discovery functional entity provides the LS URI or the ANP domain name that corresponds to the provided IP address.

NOTE 1: The VSP Call Control may have this information in a local cache, in which case Step 2 and 3 are not executed.

- 4) The VSP Call Control uses the source IP address and port of the Call Setup Request to query the Location Server for the caller's location.
- 5) The Location Server provides a location identifier, optionally a location reference and, an ESRF URI if routing information is requested.
- 6) The VSP inserts the received location identifier and location reference (if any) in the Call Setup Request and forwards to the received ESRF URI, if any, or to a URI associated to the ECSP determined by local policy.
- 7) The ESRF derives a location value from the location identifier using statically configured data. This location value is considered sufficient to select a PSAP address.
- 8) The ESRF determines the PSAP address to which to direct the emergency call, based on the location value derived from the location identifier. As part of the determination the ESRF either queries a route server or uses a locally determined PSAP address using configuration information.
- 9) The ESRF forwards the Call Setup Request to the ESRP in the PSAP Service Provider's domain, via zero, one or more intermediate entities, using standard routing procedures. The location reference received from the VSP, if any, is retained in the request. The location identifier and the location value derived from this identifier may also be included.

- 10) If the PSAP address does not uniquely identifies a PSAP, the ESRP determines the correct PSAP identifier (e.g. by applying load balancing).
- 11) The ESRP forwards the Call Setup Request to the identified PSAP via zero, one or more intermediate functional entities, using standard routing procedures.
- 12) The PSAP sends a Location Request to the LS Proxy, including a location reference, a location identifier or a network provided caller identity.
- 13) The LS Proxy forwards the request to the LS.
- 14) The LS sends back a Location Response to the LS Proxy including a location value.
- 15) The LS Proxy forwards the response back to the PSAP.

NOTE 2: Step 12-15 may not apply if the ECSP has pushed location information over the ik or im interface.

5.5.5 ANP provides location identifier to the VSP and the PSAP pulls location value

The information flow diagram in figure 5.5 describes emergency call routing and location provisioning when only the PSAP can retrieve location value from ANP LS using a received location identifier.

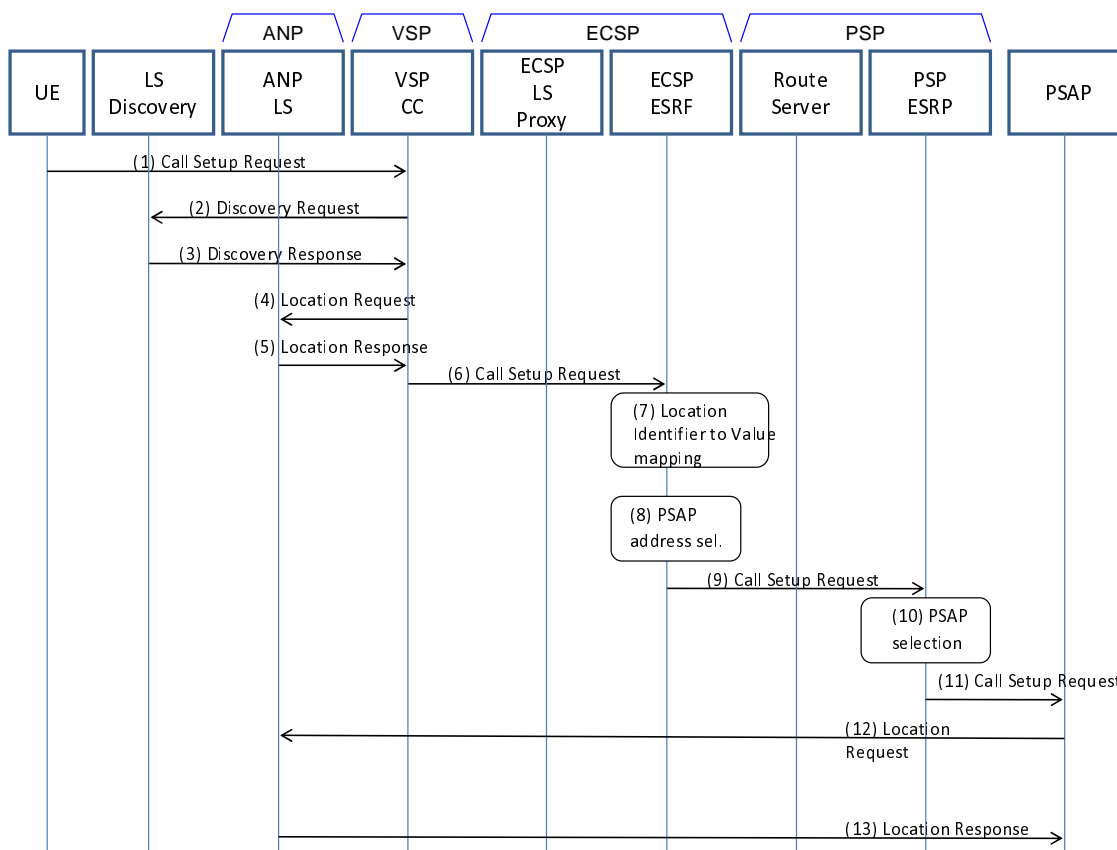

Figure 5.5: Call routing and location provisioning procedure

- 1) The UE sends a Call Setup Request to the VSP Call Control. The VSP Call Control recognizes it as an attempt to make an emergency call.
- 2) The VSP Call Control uses the source IP address of the Call Setup Request to query the LS Discovery functional entity.
- 3) The LS Discovery functional entity provides the LS URI or the ANP domain name that corresponds to the provided IP address.

NOTE: The VSP Call Control may have this information in a local cache, in which case Step 2 and 3 are not executed.

- 4) The VSP Call Control uses the source IP address and port of the Call Setup Request to query the Location Server for the caller's location.
- 5) The Location Server provides a location identifier and optionally a location reference and an ESRF URI if routing was requested.
- 6) The VSP inserts the received location identifier and location reference (if any) in the Call Setup Request and forwards to the received ESRF URI, if any, or to a URI associated to the ECSP determined by local policy.
- 7) The ESRF derives a location value from the location identifier using statically configured data. This location value may not be precisely indicate where the calling user is located but is considered sufficient to select a PSAP address.
- 8) The ESRF determines the PSAP address to which to direct the emergency call, based on the location value derived from the location identifier. As part of the determination the ESRF either queries a route server or uses a locally determined PSAP address using configuration information.
- 9) The ESRF forwards the Call Setup Request to the ESRP in the PSAP Service Provider's domain, via zero, one or more intermediate entities, using standard routing procedures. The location reference received from the VSP, if any, is retained in the request. The location identifier and the location value derived from this identifier may also be included.
- 10) If the PSAP address does not uniquely identifies a PSAP, the ESRP determines the correct PSAP identifier (e.g. by applying load balancing).
- 11) The ESRP forwards the Call Setup Request to the identified PSAP via zero, one or more intermediate functional entities, using standard routing procedures.
- 12-13) PSAP setup a query to the ANP LS directly for location value retrieval using the received location identifier.

5.6 Extension of the Functional Architecture for Networks with VPN, NAT/PAT and other components which change Packet Flow Identity

Network elements that change packet flow identity information (IP address and/or port) between the access network and the VSP call control can cause problems in the functional architecture, because the LS Discovery function fails or provides incorrect results with the consequence that the access network, to which the UE is physically attached, cannot be identified and the correct Location Server cannot be found.

In any case, a mechanism is required that enables the VSP to obtain the domain name of the ANP or the URI of the Location Server serving this domain from the UE's IP address as seen by the VSP. The domain name can be used to identify the Location Server of the access network.

Annex A (normative) provides two possible solutions to address the problem of changes in packet flow identity information.

5.7 Extension of the Functional Architecture to support VSP Aggregation Providers

In cases where an aggregation VSP is collecting the emergency calls from various VSPs, which do not have a direct interconnection to the ESRF, the extension of the functional architecture as described in annex C (normative) applies.

6 Protocol and other requirements

6.1 Generic requirements

The protocols used on the interfaces between the ANP, the VSP, the ECSP and an IP-based PSP domain shall at least comply with the following requirements:

- 1) The protocols shall be extensible and support forward and backward compatibility between versions.
- 2) The protocols shall be able to operate in the presence of NAT devices.
- 3) When items appear in different rows in the information flows descriptions in clause 5.3.2, the protocols shall ensure distinguishing them without ambiguity, e.g., distinguishing network-provided from user-provided location information.
- 4) In case the access network supports mobility during a call session the protocols on the relevant interfaces shall support location updates.

6.2 Trust relationships

Another important aspect is the trust needed for some information exchanges. Trust implies that the receiver of information has authenticated the sender of to make sure that the information received is reliable.

A VSP need not be in the same country as the user requesting the emergency call, but the emergency service is intended to be delivered in the country where the user is located.

This implies that the entities involved in the emergency service should make sure that:

- The privacy of the information regarding the final user is guaranteed.
- The information enabling the service is reliable.
- The integrity of the assets of the different entities and providers is preserved against illegal unauthorized access.

In the following some essential and general remarks needed for the comprehension of the technical specifications are provided, and guidance for the protocol specification is given.

The following information exchanges should rely on trust relationships:

- between the VSP and the ECSP (ie): the trust enables the information about IP address and source port, and any network-provided location reference or network-provided location identifier, to be reliable for the ECSP; the same applies when the relationship between the two entities is intermediated by a VAP, with the latter establishing trust relationships with the served VSPs and ECSPs;
- between ANP, ECSP, PSP and PSAP: are a matter for the country concerned but some form of trust is expected, such that any privacy and integrity of location information is preserved;
- between the ANP and the VSP (ic): requiring a bilateral trust relationship is in many cases impractical; a method to manage the information exchange without requiring VSP authentication is outlined in annex D.

Trust relationships on the other interfaces are out of scope for the purpose of the present document or covered elsewhere by existing general mechanisms.

Annex A (normative): Extension of the Functional Architecture for Networks with VPN, NAT/PAT and other components which change Packet Flow Identity

A.1 General

This annex defines an extension to the main architecture in clause 5.1, and defines how to handle network elements that change packet flow identity information between the access network and the VSP call control. These network elements that include NAT/PAT devices and VPN tunnel endpoints are hereafter collectively referred to as FlowChangers.

An example involving a FlowChanger might be a UE attached to Access Network 1 creating a VPN tunnel into Access Network 2 and then the UE initiating an emergency call.

FlowChangers create a problem, because the VSP sees the packet flow identity created by the FlowChanger rather than the original packet flow Identity from the access network to which the UE is physically attached. It is the identity assigned by the physically attached access network that is required in order to obtain location information.

FlowChangers may reside inside or outside a common regulatory emergency service boundary. Where a FlowChanger resides outside the common regulatory emergency service boundary commercial agreements may be required in order to ensure correct back-tracking to the access network physically serving the UE.

The following clauses outline 2 possible solutions for the problem described above.

A.2 LS chaining solution

This solution treats each FlowChanger as a new access network and as such is required to provide its own LS. The LS inside this network is responsible for being able to map from an outbound identity flow to an inbound identity flow and so create a chain back from the VSP to the LS in the access network to which the UE is physically attached. Depending on the configuration of the network one LS may serve several FlowChanger devices. When deployed in this configuration the LS shall obtain the mapping data for each identity flow change. From the viewpoint of the VSP, ESRF and PSAP a deployment with one LS serving several FlowChangers looks like a single access network.

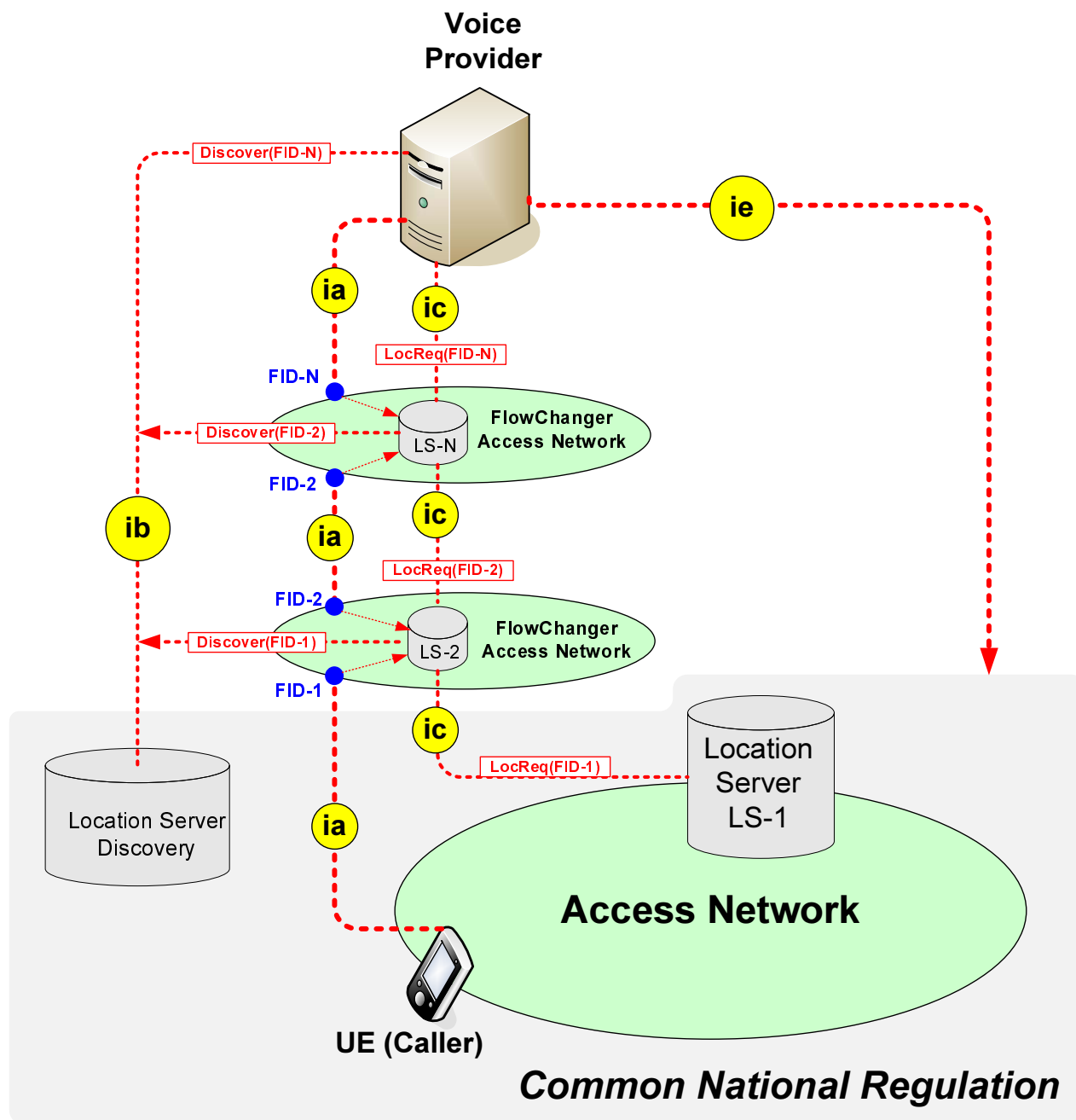

Figure A.1: FlowChanger impacts to functional architecture

The call from the UE to the VSP may go through any number of FlowChangers. In figure A.1, the VSP sees the call arriving with flow identity FID-N, and it uses this flow identity on the ib interface to determine the address of LS-N in the last FlowChanger access network. The VSP makes a location request to LS-N using FID-N as the identity of the UE. LS-N cannot determine the location of the UE but it knows or is able to determine the relationship between the outgoing flow identity, FID-N, and incoming flow identity, FID-2 so it can use FID-2 to determine the identity of the preceding FlowChanger network and using the ib interface the associated LS, LS-2. LS-N then makes a location request to LS-2 using FID-2 as the identity of the UE. Similarly, LS-2 is able to associate FID-2 with FID-1 and use the ib interface to determine the address of LS-1 and make a location request using FID-1 as UE identity. To the LS-1 the location request appears to have come from a VSP, so it responds with a location URI and the address of the ESRF to forward the call to. This response is then handed back up the chain to the VSP.

This approach means that no new external interfaces are introduced and that FlowChangers in the signalling path are transparent to both the VSP and the LS in the originating access network. The common ib interface is used to determine the correct location server and the ic interface is used to request and receive location and routing information.

A.2.1 Location chaining interface impacts

With the LS chaining solution more than one LS is involved and a LS discovery invocation for each LS in the chain. This results in the following interface impacts:

ia:

The connection can pass through more than one access network and for each access network a FlowChanger can change the packet flow identity. Each leg of the communication provides sufficient information to enable the VSP call control and each location server in the chain to invoke LS discovery to the next access network in the chain.

ib:

The VSP call control and all involved location servers provide sufficient information to allow the LS discovery functional element to provide the address of either the next LS in the chain or the LS from the access network serving the user equipment.

ic:

The VSP control and all other location servers in the chain include sufficient information to allow the next LS in the chain to identify the connection either to the next LS or the UE. The location server serving the UE in the ANP return the location information of the UE, each location server in the chain subsequently returns this location information to the VSP.

A.3 HOST_ID solution

The solution requires FlowChangers to inject a HOST_ID in all packets they forward as described in IETF RFC 6967 [i.2] and further elaborated in [i.3]. IETF RFC 6967 [i.2] considers 9 possible mechanisms for conveying HOST_ID information through FlowChangers but explicitly recommends against several of them. The mechanisms not recommended in IETF RFC 6967 [i.2] are not considered suitable for use in the present document.

NOTE: Although the protocol solution for conveying a HOST_ID is still under discussion at the IETF, for simplicity the following figures assume that a HOST_ID is conveyed in an extension to the IP header.

If the FlowChanger is a NAT device (e.g. a CGN), the HOST_ID shall contain the IP address and port as known by the LS. Therefore, when multiple NAT devices are present between the two domains, the HOST ID shall be injected by the first one within or after the ANP domain.

If the FlowChanger is a VPN tunnel, the HOST_ID shall be injected by the tunnel endpoint and shall contain the external address of the tunnel as known by the LS. Therefore, when multiple tunnels are embedded, the HOST_ID shall be injected by the remote endpoint of the tunnel whose external address is assigned by a server in the ANP's domain.

Figure A.2 illustrates a use case where the FlowChanger is a VPN tunnel with a tunnel endpoint in the VSP.

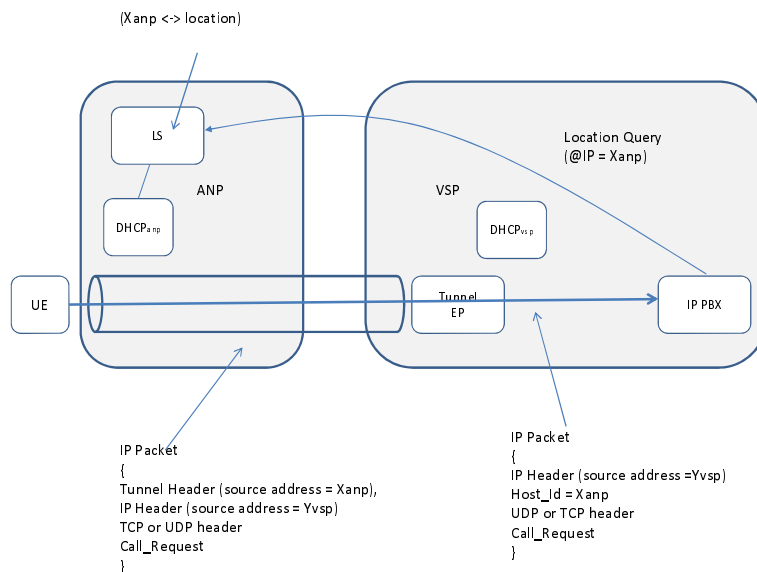

Figure A.2: LS query via VPN tunnel

Figure A.3 provides the information flow diagram for this use case.

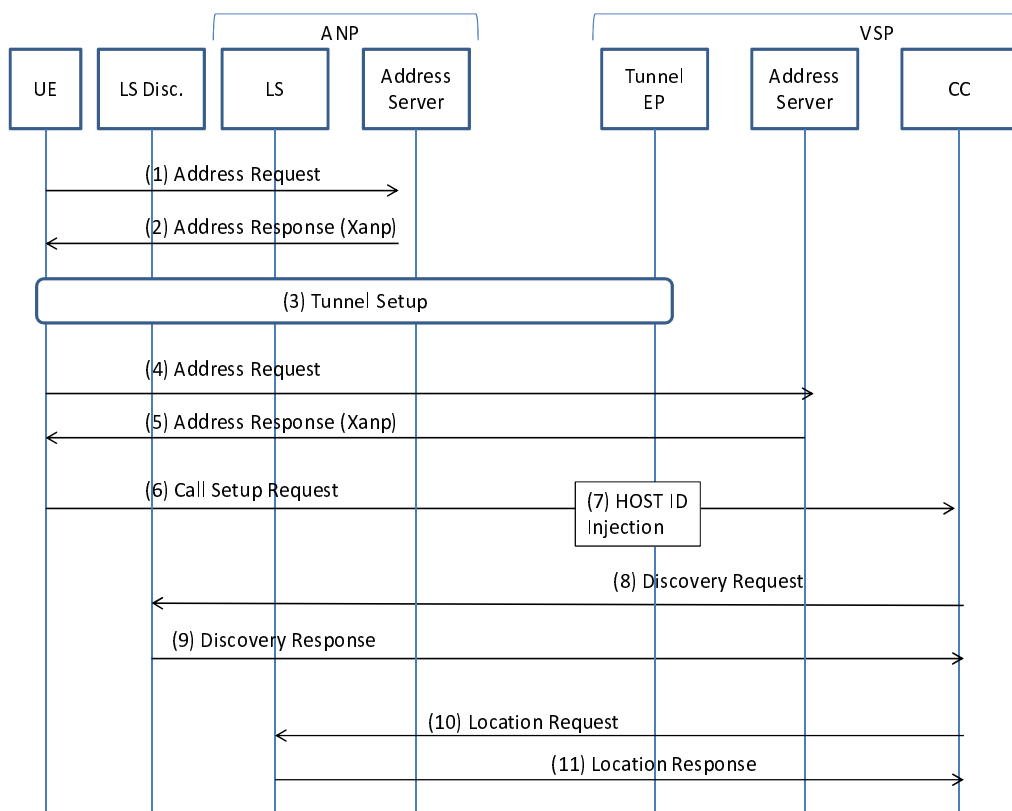

Figure A.3: Configuration with a VPN tunnel

- 1-2) The UE obtains an IP address and port Xanp from an address server (e.g. a DHCP server) in the ANP's domain.
- 3) The UE sets up a tunnel up to an entry point in the VSP's domain.
- 4-5) Within the tunnel, the UE obtains an IP address and port (Yvsp) from a server in that domain.

6-7) The UE sends a Call Setup Request and the tunnel endpoint injects a HOST ID with the value Xanp in the packet header.

8-11) The VSP Call Control function entity (e.g. an IP PBX) extracts the HOST ID value from the IP header of the call setup request and uses this value to discover and query the LS.

Figure A.4 illustrates a use case where the FlowChanger is a Carrier Grade NAT (CGN) between the ANP and the VSP's domains.

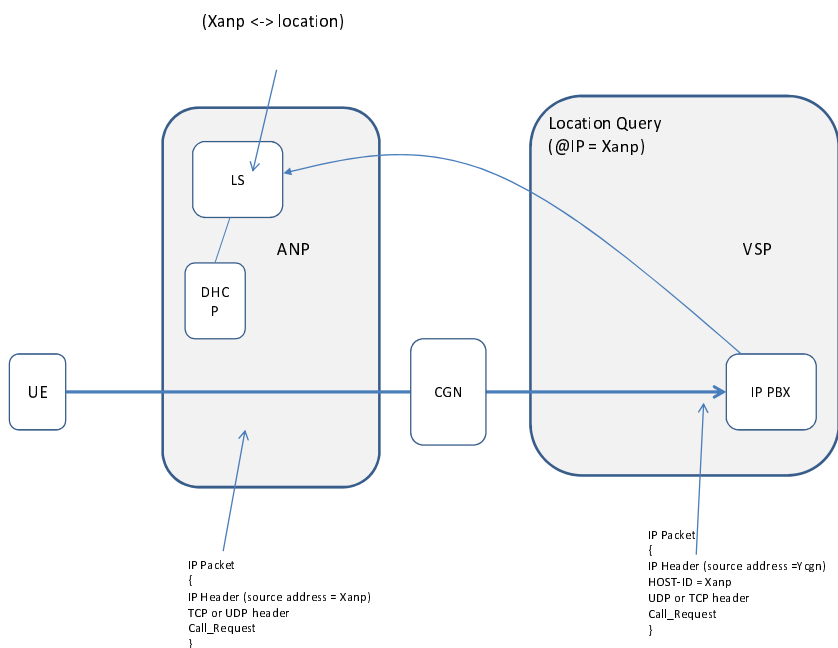

Figure A.4: LS query via carrier grade NAT

Figure A.5 provides the information flow diagram for this use case.

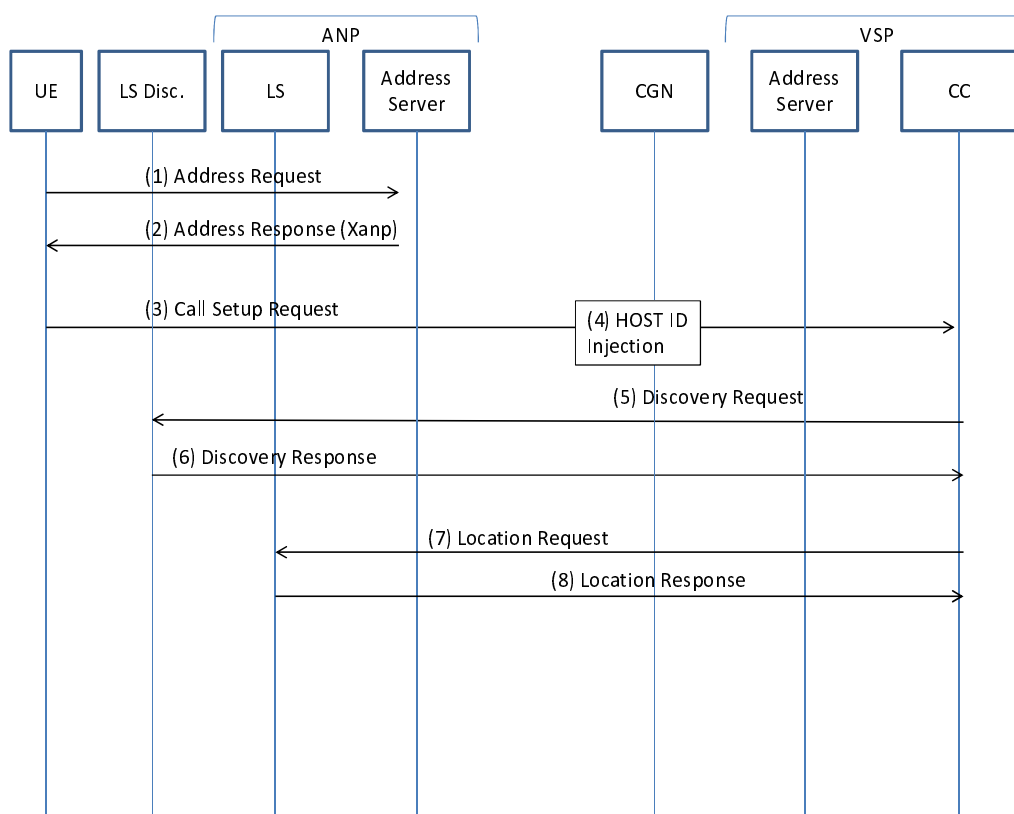

Figure A.5: Location retrieval with a CGN

- 1-2) The UE obtains an IP address and port Xanp from an address server (e.g. a DHCP server) in the ANP's domain.
- 3-4) The UE sends a Call Setup Request to the VSP, via the NAT device which modifies the source address and port number and injects a HOST ID with the value Xanp in the packet header.
- 5-8) The VSP Call Control function entity (e.g. an IP PBX) extracts the HOST ID value from the IP header of the call setup request and uses this value to discover and query the LS.

Annex B (informative): M/493 Scope

This annex contains clause 3 "Scope of the Mandate" of the European Commission mandate M/493 "Standardisation Mandate to the European Standards Organisations (ESO) in Support of the Location Enhanced Emergency Call Service" [i.4].

"The determination and transport of caller location information for VoIP needs to be fully standardised including a single functional model, the necessary interfaces and protocols. The location information should be provided as a pure enhancement to the basic emergency call service. It should not interfere in any way with the quality or operation of the basic emergency call service. Because a PSAP continues to be connected by means of a fixed network, e.g. ISDN access line, it should be able to continue to behave in its traditional manner. The enhancement, i.e. location data provision, is expected to be determined by the originating telephony or electronic communications service provider, capable of originating voice calls through a number or numbers in national telephone numbering plans, and be provided at call setup to the PSAP as soon as the call reaches the authority handling the emergency calls. It may be delivered by means of traditional or new methods. If an IP-based solution for the provision of the location information is developed, the correlation between voice and data and timely provision at call setup time must be achieved, and special consideration should be given to data protection and privacy/security issues. In addition, the provision of caller location information should be implemented in a way that ensures that access for disabled end-users to emergency services is equivalent to that enjoyed by other end-users.

The process for the determination of the location of fixed and more importantly nomadic VoIP users in case of an emergency is required. This is particularly needed when the originating VoIP service provider is an enterprise separate from lower layer service providers as well as one or several contributing infrastructure operators. The information exchanges between the service providers and network operators involved needs to be standardized. This should include also IP-biased VoIP providers, including also Skype out.

Experience shows that network operators tend to migrate from present implementations to a new and complex technology like NGN in a long-lasting and conservatively phased approach. A solution relying on a completely standardised and fully functional NGN being implemented by all parties involved is at present and in the near future of no use because it is not realistic to assume that this will be the case in the foreseeable future. A practical solution for today's pre-NGN IP-based networks is required, ensuring to the utmost extent possible forward compatibility with the future all-NGN technical environment.

The European Standardisation Organisations are invited to prepare a coherent and complete set of specifications or standards containing the architecture, the interfaces and the protocols in support of the requirements set by article 26 of the amended Directive 2002/22/EC concerning the determination, transport and delivery of caller location information. This work shall not be focused on NGN but shall address current implementations for all types of voice calls (fixed, mobile, static and nomadic VoIP) in EU countries. The standards should allow for the determination of the location information in the form of a geographical coordinate or a civic address as precisely as possible.

The specifications or standards should not expect from the PSAPs to apply any network access technologies other than those in use today on fixed network access lines, e.g. ISDN Basic/Primary Rate Interfaces and/or a broadband IP access, e.g. by xDSL. Furthermore, it must be pointed out that the obligations under the Universal Service Directive, such as unfettered bi-directional speech communication in real-time, fast call setup and provision of the caller's E.164 number, must not be hampered.

The mandated specifications or standards should not impact on the continued operation of the current emergency call service. The measures taken to provide the location information should not significantly delay the establishment of the emergency call. The measures should include a compatibility mechanism allowing future enhancements. Finally, the location information should be carried from all types of originating networks and providers, e.g. fixed, mobile, VoIP, NGN, in a uniform manner that allows the reception at a single homogenous interface at the PSAP.

The mandated specifications and standards should ensure that the determination and transport of caller information for emergency calls cannot be used to obtain location information for other purposes without the consent of the user or subscriber."

NOTE: "Skype" is a trade mark.

Annex C (normative): Extension of the Functional Architecture to support an aggregating VSP

C.1 General

This annex defines an extension to the main architecture in clause 5.1, and defines how to support an aggregating VSP.

In cases where an aggregation VSP is collecting the emergency calls from various VSPs, which do not have a direct interconnection to the ESRF, the following extension of the functional architecture applies (see figure C.1).

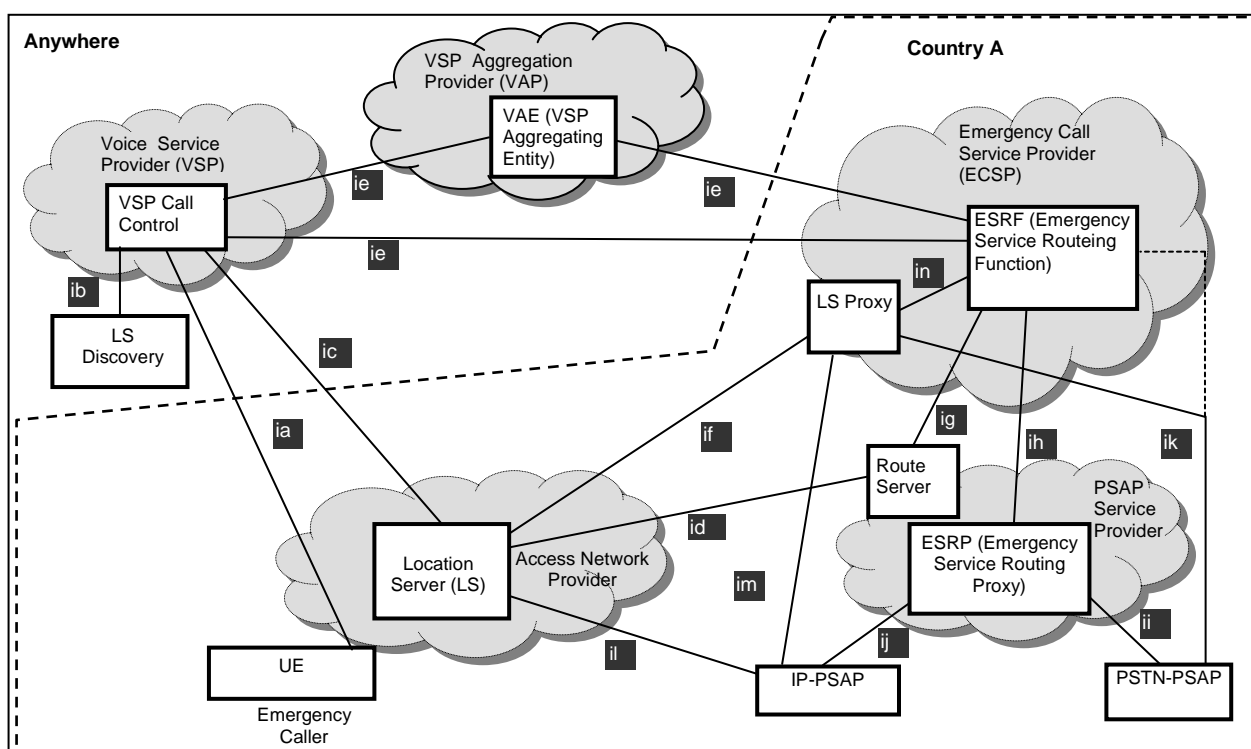

Figure C.1: High level Functional Architecture incl. aggregation VSP

C.2 Architectural requirements for VSP Aggregation Provider (VAP)

In addition to the requirements in clause 5.2, the following applies.

The VAP:

- VAP-R1) shall be capable of receiving emergency calls from a trusted sender (e.g. a VSP or a VAP);
- VAP-R2) shall receive the destination ECSP in the same regulatory domain in the UE, trusted UE identity and location information from the trusted sender;
- VAP-R3) shall direct the emergency call to an identified emergency call handler (e.g. ECSP or another VAP) with whom a trust relationship exists;
- VAP-V4) shall convey the caller location information to the ECSP; and

VAP-R5) should convey information provided by the UE to the ECSP.

C.3 Extended Interface definition

In addition to the interface definition in clause 5.3. the following applies.

ie:

Interface between the VSP call control or the VSP aggregating entity and the serving ESRF in the ECSP network.

The VSP call control or the VSP aggregating entity adds the location information and directs the call to the ESRF address.

C.4 VSP Aggregating Entity

In addition to the functional entities in clause 5.4. the following applies:

A VSP aggregating entity resides inside the VSP aggregation provider network and may be used by a VSP or group of VSPs to manage trust relationships with, and routeing to, ECSPs or other VAEs that reside in other areas or countries. The VAE may also generate call data records for calls using its services.

Upon receipt of an emergency call request from a VSP or VAE with which the VAE has a trust relationship, the VAE:

- 1) shall address the call to the trusted emergency handler (e.g. VAP or ECSP);
- 2) shall forward the emergency call to the trusted emergency handler (e.g. VAP or ECSP).

Annex D (informative): Avoiding authentication between the VSP and the ANP

Requiring mutual authentication between a VSP and an ANP in order to request and provide location and routing information is an impediment to the deployment of this architecture. This annex provides call flows and interactions that if followed can avoid the need for mutual authentication.

In order for this mechanism to work in a secure manner, some steps should be taken by the ANP:

- Location is provided to the VSP in the form a location reference that can only be dereferenced by an authorized entity. This approach stops the ANP from inadvertently providing location information to a rogue Internet entity.
- The VSP needs to have confidence that the ANP has administrative authority over the IP address range and domain in which the UE resides. This can be achieved by having the ANP obtain an X.509 certificate from a well known root certificate authority certifying that the ANP has administrative authority over the registered domain. Acquiring this certificate also allows the communications between the VSP and ANP to be secured from would-be eavesdroppers.
- In order to shield actual user locations from the Internet, the ANP provides inner and outer location servers, with the inner location server only being accessible via the outer location server. The outer location server is only ever presented with location information that satisfies the authentication credentials of the requesting party. In the case that the requesting party does not authenticate with the outer location server then only a location reference will be provided.
- An ANP under Internet attack (e.g. denial of service) can decide to ignore requests for location and routing information.

Figure D.1 illustrates the steps to follow in order to allow an ANP to provide location and routing information to a requesting VSP without requiring the need for the VSP to authenticate with the ANP.

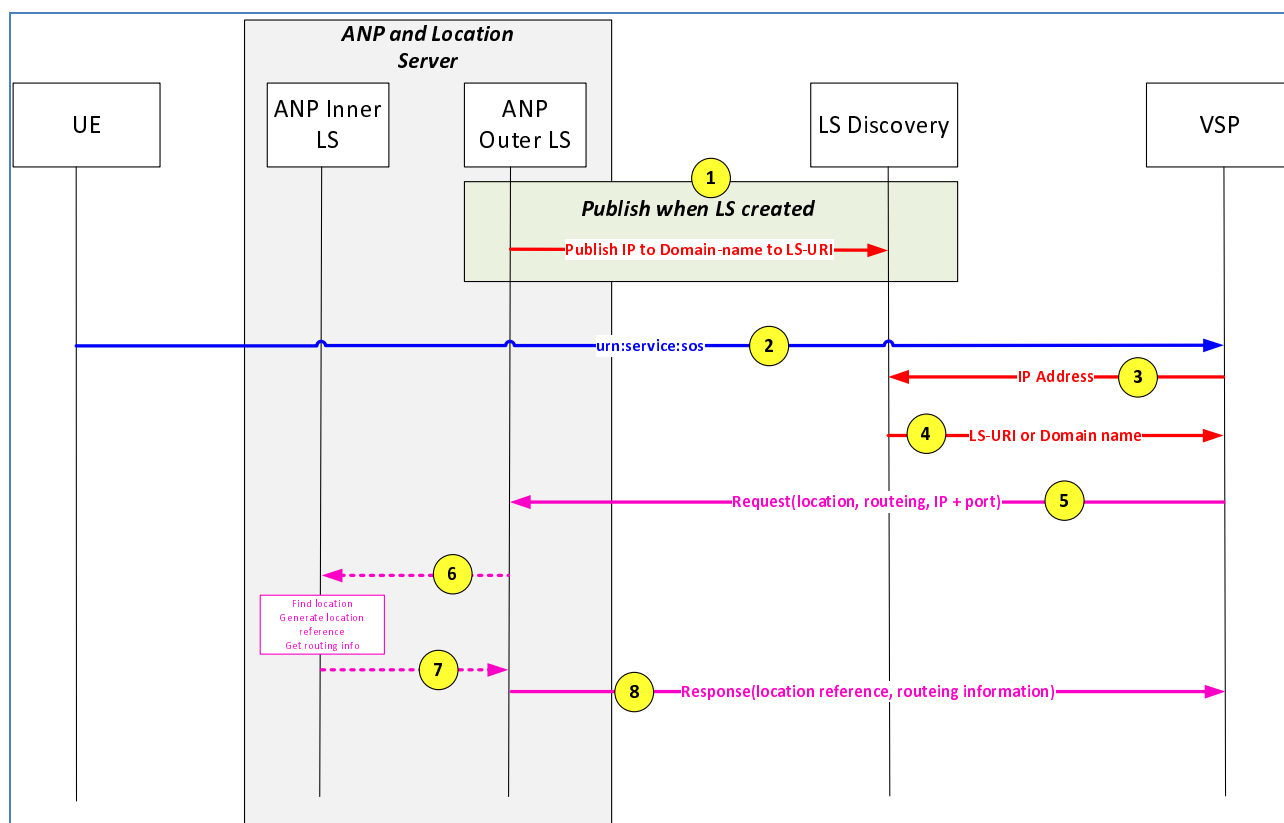

Figure D.1: Non-Authenticating Call Flow

- 1) This is the pre-step of ANP publishing the necessary information to the LS Discovery function (see clause 5.4.5.1).
- 2) UE makes an emergency call via its home VSP.
- 3) VSP queries the LS Discovery function using the public IP address of the UE.
- 4) LS Discovery, using the information provided by the ANP, returns the LS URI or domain name corresponding to the proffered IP address.
- 5) VSP requests location and routing information from the LS in the ANP.
- 6) The outer LS at the ANP, authenticates (or not in this case) the VSP and passes the request on to the inner LS.
- 7) The inner LS determines the location value and subsequent routing information, then generates a location reference and returns only the location reference and routing information to the outer LS.
- 8) The outer LS then returns the location reference and the routing information to the VSP.

How the outer LS conveys the identity of the entity requesting location to the inner LS is a matter of implementation.

History

Document history		
V1.0.0	April 2014	Membership Approval Procedure MV 20140606: 2014-04-07 to 2014-06-06
V1.0.5	December 2014	Membership Approval Procedure MV 20150221: 2014-12-23 to 2015-02-23
V1.1.1	February 2015	Publication